

TEST REPORT

CERTIFICATE OF CONFORMITY

Standard: 47 CFR FCC Part 15, Subpart E (Section 15.407)
Report No.: RFBFBFBE-WTW-P22031259A-1
FCC ID: I88EX5512-T0
Model No.: EX5512-T0
Received Date: 2022/6/1
Test Date: 2022/6/7 ~ 2022/7/23
Issued Date: 2022/9/12

Applicant: Zyxel Communications Corporation
Address: No.2 Industry East RD. IX, Hsinchu Science Park, Hsinchu 30075, Taiwan
Issued By: Bureau Veritas Consumer Products Services (H.K.) Ltd., Taoyuan Branch
Hsin Chu Laboratory
Lab Address: E-2, No.1, Li Hsin 1st Road, Hsinchu Science Park, Hsinchu City 300, Taiwan
Test Location: E-2, No.1, Li Hsin 1st Road, Hsinchu Science Park, Hsinchu City 300, Taiwan
FCC Registration / 723255 / TW2022
Designation Number:

Approved by: _____, **Date:** 2022/9/12
May Chen / Manager

This test report consists of 129 pages in total. It may be duplicated completely for legal use with the approval of the applicant. It should not be reproduced except in full, without the written approval of our laboratory. The test results in the report only apply to the tested sample. The test results in this report are traceable to the national or international standards.



Prepared by : Cherry Chuo / Specialist

This report is governed by, and incorporates by reference, the Conditions of Testing as posted at the date of issuance of this report at <http://www.bureauveritas.com/home/about-us/our-business/cps/about-us/terms-conditions/> and is intended for your exclusive use. Any copying or replication of this report to or for any other person or entity, or use of our name or trademark, is permitted only with our prior written permission. This report sets forth our findings solely with respect to the test samples identified herein. The results set forth in this report are not indicative or representative of the quality or characteristics of the lot from which a test sample was taken or any similar or identical product unless specifically and expressly noted. Our report includes all of the tests requested by you and the results thereof based upon the information that you provided to us. Measurement uncertainty is only provided upon request for accredited tests. Statements of conformity are based on simple acceptance criteria without taking measurement uncertainty into account, unless otherwise requested in writing. You have 60 days from date of issuance of this report to notify us of any material error or omission caused by our negligence or if you require measurement uncertainty; provided, however, that such notice shall be in writing and shall specifically address the issue you wish to raise. A failure to raise such issue within the prescribed time shall constitute your unqualified acceptance of the completeness of this report, the tests conducted and the correctness of the report contents.

Table of Contents

Release Control Record	4
1 Certificate.....	5
2 Summary of Test Results	6
2.1 Measurement Uncertainty	6
2.2 Supplementary Information	6
3 General Information	7
3.1 General Description of EUT	7
3.2 Antenna Description of EUT	8
3.3 Channel List.....	11
3.4 Power Setting	12
3.5 Test Mode Applicability and Tested Channel Detail.....	13
3.6 Duty Cycle of Test Signal.....	14
3.7 Test Program Used and Operation Descriptions	15
3.8 Connection Diagram of EUT and Peripheral Devices	15
3.9 Configuration of Peripheral Devices and Cable Connections	16
4 Test Instruments	17
4.1 26 dB Bandwidth	17
4.2 RF Output Power.....	17
4.3 Power Spectral Density	17
4.4 Occupied Bandwidth.....	17
4.5 Frequency Stability	18
4.6 AC Power Conducted Emissions	18
4.7 Unwanted Emissions below 1 GHz	19
4.8 Unwanted Emissions above 1 GHz.....	20
5 Limits of Test Items.....	22
5.1 26 dB Bandwidth	22
5.2 RF Output Power.....	22
5.3 Power Spectral Density	22
5.4 Occupied Bandwidth.....	22
5.5 Frequency Stability	22
5.6 AC Power Conducted Emissions	23
5.7 Unwanted Emissions below 1 GHz	23
5.8 Unwanted Emissions above 1 GHz.....	24
6 Test Arrangements.....	25
6.1 26 dB Bandwidth	25
6.1.1 Test Setup	25
6.1.2 Test Procedure.....	25
6.2 RF Output Power.....	25
6.2.1 Test Setup	25
6.2.2 Test Procedure.....	25
6.3 Power Spectral Density	26
6.3.1 Test Setup	26
6.3.2 Test Procedure.....	26
6.4 Occupied Bandwidth.....	26
6.4.1 Test Setup	26
6.4.2 Test Procedure.....	26
6.5 Frequency Stability	27
6.5.1 Test Setup	27
6.5.2 Test Procedure.....	27
6.6 AC Power Conducted Emissions	28
6.6.1 Test Setup	28
6.6.2 Test Procedure.....	28
6.7 Unwanted Emissions below 1 GHz	29
6.7.1 Test Setup	29



6.7.2	Test Procedure	30
6.8	Unwanted Emissions above 1 GHz	31
6.8.1	Test Setup	31
6.8.2	Test Procedure	31
7	Test Results of Test Item	32
7.1	26 dB Bandwidth	32
7.2	RF Output Power	36
7.3	Power Spectral Density	54
7.4	Occupied Bandwidth	60
7.5	Frequency Stability	63
7.6	AC Power Conducted Emissions	64
7.7	Unwanted Emissions below 1 GHz	66
7.8	Unwanted Emissions above 1 GHz	68
8	Pictures of Test Arrangements	128
9	Information of the Testing Laboratories	129



Release Control Record

Issue No.	Description	Date Issued
RFBFBE-WTW-P22031259A-1	Original release.	2022/9/12

1 Certificate

Product: AX6000 WiFi 6 Multi-Gigabit Ethernet Gateway

Brand: ZYXEL

Test Model: EX5512-T0

Sample Status: Engineering sample

Applicant: Zyxel Communications Corporation

Test Date: 2022/6/7 ~ 2022/7/23

Standard: 47 CFR FCC Part 15, Subpart E (Section 15.407)

Measurement ANSI C63.10-2013

procedure: KDB 789033 D02 General UNII Test Procedure New Rules v02r01

KDB 662911 D01 Multiple Transmitter Output v02r01

The above equipment has been tested by **Bureau Veritas Consumer Products Services (H.K.) Ltd., Taoyuan Branch**, and found compliance with the requirement of the above standards. The test record, data evaluation & Equipment Under Test (EUT) configurations represented herein are true and accurate accounts of the measurements of the sample's RF characteristics under the conditions specified in this report.

2 Summary of Test Results

47 CFR FCC Part 15, Subpart E (Section 15.407)			
Clause	Test Item	Result	Remark
15.407(a)(2)	26 dB Bandwidth	-	For U-NII-2A U-NII-2C Band output power limitation is determined based on 26dBc bandwidth.
15.407(a)(1/2)	RF Output Power	Pass	Meet the requirement of limit.
15.407(a)(1/2)	Power Spectral Density	Pass	Meet the requirement of limit.
---	Occupied Bandwidth	-	Reference only.
15.407(g)	Frequency Stability	Pass	Meet the requirement of limit.
15.407(b)(9)	AC Power Conducted Emissions	Pass	Minimum passing margin is -9.94 dB at 0.36482 MHz
15.407(b)(9)	Unwanted Emissions below 1 GHz	Pass	Minimum passing margin is -3.4 dB at 42.88 MHz
15.407(b) (1/2/3/10)	Unwanted Emissions above 1 GHz	Pass	Minimum passing margin is -0.6 dB at 5350.00, 5457.73, 5725.00 MHz
15.203	Antenna Requirement	Pass	Antenna connector is ipex(MHF) not a standard connector.

Note: Determining compliance based on the results of the compliance measurement, not taking into account measurement instrumentation uncertainty.

2.1 Measurement Uncertainty

Where relevant, the following measurement uncertainty levels have been estimated for tests performed on the EUT as specified in CISPR 16-4-2:

Measurement	Specification	Expanded Uncertainty (k=2) (±)
AC Power Conducted Emissions	150 kHz ~ 30 MHz	1.9 dB
Unwanted Emissions below 1 GHz	9 kHz ~ 30 MHz	3.1 dB
	30 MHz ~ 1 GHz	5.4 dB
Unwanted Emissions above 1 GHz	1 GHz ~ 18 GHz	5.0 dB
	18 GHz ~ 40 GHz	5.3 dB

The other instruments specified are routine verified to remain within the calibrated levels, no measurement uncertainty is required to be calculated.

2.2 Supplementary Information

There is not any deviation from the test standards for the test method, and no modifications required for compliance.

3 General Information

3.1 General Description of EUT

Product	AX6000 WiFi 6 Multi-Gigabit Ethernet Gateway
Brand	ZYXEL
Test Model	EX5512-T0
Status of EUT	Engineering sample
CPU Model No.	MT7986A
RF Chip Model No.	2.4G Chip Model: MT7976G 5G Chip Model: MT7976A
FW Version	V5.70(ACEG.0)b3
Power Supply Rating	12Vdc from Adapter
Modulation Type	64QAM, 16QAM, QPSK, BPSK for OFDM 256QAM for OFDM in 11ac mode 1024QAM for OFDMA in 11ax mode
Modulation Technology	OFDM, OFDMA
Transfer Rate	802.11a: up to 54Mbps 802.11n: up to 600Mbps 802.11ac: up to 1733.3 Mbps 802.11ax: up to 2401.9 Mbps
Operating Frequency	5250 ~ 5320 MHz 5500 ~ 5720 MHz
Number of Channel	802.11a, 802.11n (HT20), 802.11ac (VHT20), 802.11ax (HE20): 16 802.11n (HT40), 802.11ac (VHT40), 802.11ax (HE40): 8 802.11ac (VHT80), 802.11ax (HE80): 4 802.11ac (VHT160), 802.11ax (HE160): 2
Output Power	CDD Mode 5250 ~ 5320 MHz : 246.228 mW (23.91 dBm) 5500 ~ 5720 MHz : 248.19 mW (23.95 dBm) Beamforming Mode 5250 ~ 5320 MHz : 214.528 mW (23.31 dBm) 5500 ~ 5720 MHz : 214.796 mW (23.32 dBm)
Accessory Device	- AC Adapter x1, Brand:MNC, Model:MAUS-1202503000 - Ethernet Cable x1 (1m, Non-shielded)

Note:

- This is a supplementary report of Report No.: RFBFBE-WTW-P22031259-1. design changed is as the following:
 - ◆ Add DFS band <5250~5350 MHz & 5470~5725 MHz> by software.
- According to above conditions, for DFS band all of test items need to be performed and all data was verified to meet the requirements.
- The EUT power needs to be supplied from a power adapter, the information is as below table:

Brand	Model	Specification
MNC	MAUS-1202503000	AC Input : 100-240V 50/60Hz, 0.8A DC Output : 12V/2.5A DC Cable : 1.5m, Non-shielded

- Simultaneously transmission condition.

Condition	Technology	
1	WLAN 2.4GHz	WLAN 5GHz

Note: The emission of the simultaneous operation has been evaluated and no non-compliance was found.

- The above EUT information is declared by manufacturer and for more detailed features description, please refers to the manufacturer's specifications or user's manual.

3.2 Antenna Description of EUT

1. The antenna information is listed as below.

Antenna No.	RF Chain No.	Brand	Model	Antenna Net Gain(dBi)	Frequency range (GHz)	Antenna Type	Connector Type
2G_ANT1	2G_Chain2	M.gear	56-001-000240Z	2.6	2.4~2.4835	Dipole	ipex(MHF)
2G_ANT2	2G_Chain0	M.gear	56-001-000241Z	3.3	2.4~2.4835	Dipole	ipex(MHF)
2G_ANT3	2G_Chain1	M.gear	56-001-000247Z	3.1	2.4~2.4835	Dipole	ipex(MHF)
2G_ANT4	2G_Chain3	M.gear	56-001-000242Z	3.2	2.4~2.4835	Dipole	ipex(MHF)
5G_ANT5	5G_Chain0	M.gear	56-001-000243Z	3.2	5.15~5.25	Dipole	ipex(MHF)
				3.4	5.25~5.35		
				4.0	5.47~5.725		
				3.3	5.725~5.85		
				3.6	5.850~5.895		
5G_ANT6	5G_Chain1	M.gear	56-001-000244Z	2.5	5.15~5.25	Dipole	ipex(MHF)
				2.2	5.25~5.35		
				3.2	5.47~5.725		
				2.4	5.725~5.85		
				2.7	5.850~5.895		
5G_ANT7	5G_Chain2	M.gear	56-001-000245Z	3.6	5.15~5.25	Dipole	ipex(MHF)
				3.8	5.25~5.35		
				3.9	5.47~5.725		
				3.8	5.725~5.85		
				4.2	5.850~5.895		
5G_ANT8	5G_Chain3	M.gear	56-001-000246Z	2.4	5.15~5.25	Dipole	ipex(MHF)
				3.4	5.25~5.35		
				3.4	5.47~5.725		
				3.2	5.725~5.85		
				3.2	5.850~5.895		

* Detail antenna specification please refer to antenna datasheet and/or antenna measurement report.

* Antenna port location

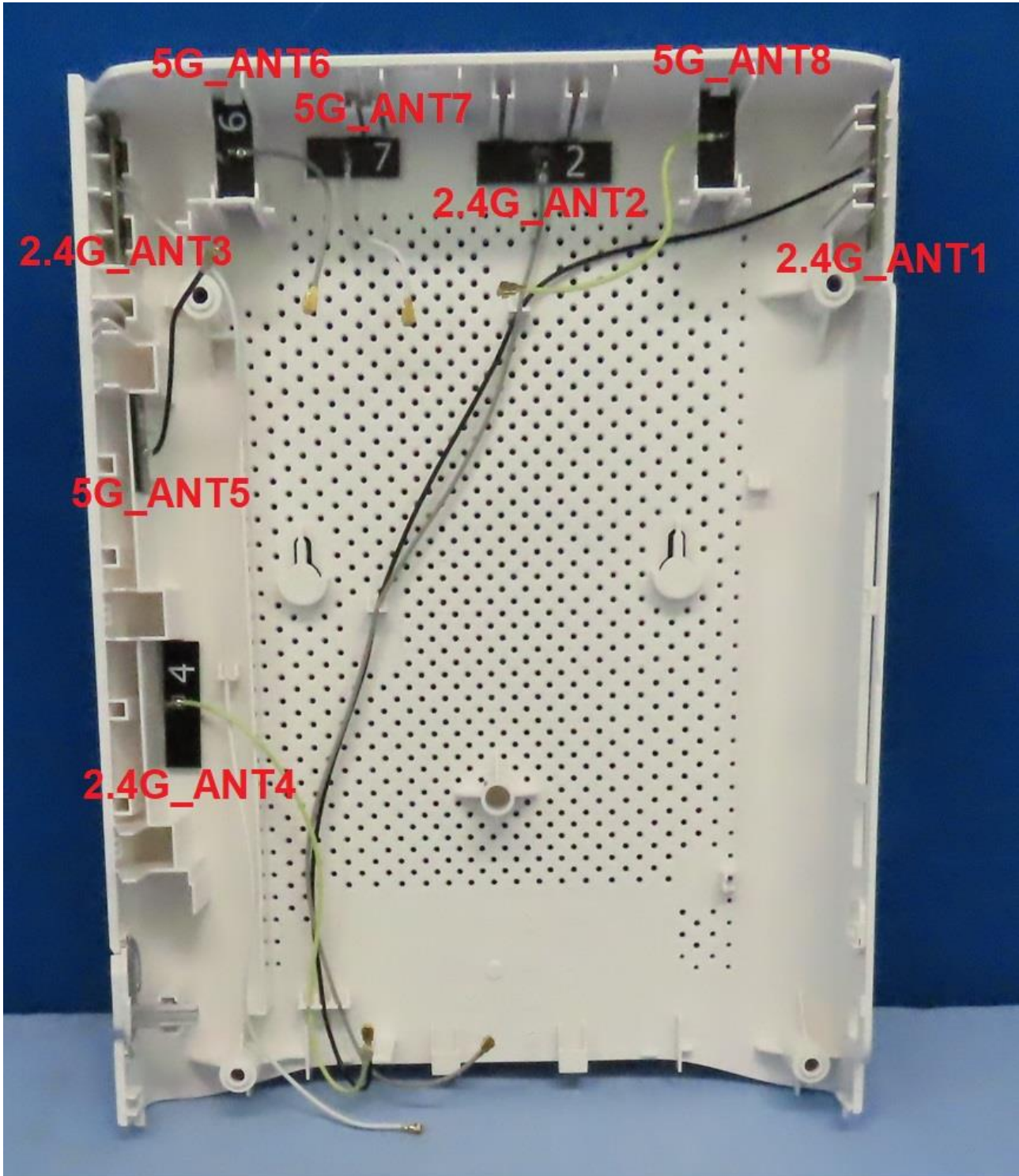

2. The directional antenna gain, please refer to the following table:

Frequency Range (GHz)	Directional Antenna Gain (dBi)	Antenna Type	Antenna Connector
5.15~5.25	6.49	Dipole	ipex(MHF)
5.25~5.35	6.66		
5.47~5.725	6.62		
5.725~5.85	5.57		

Note: Directional gain is the measured value according to KDB 662911 D03 Method of MIMO Antenna Gain Measurement. More detailed information, please refer to antenna specification.

3. The EUT incorporates a MIMO function:

5 GHz Band		
Modulation Mode	TX & RX Configuration	
802.11a	4TX	4RX
802.11n (HT20)	4TX	4RX
802.11n (HT40)	4TX	4RX
802.11ac (VHT20)	4TX	4RX
802.11ac (VHT40)	4TX	4RX
802.11ac (VHT80)	4TX	4RX
802.11ac (VHT160)	4TX	4RX
802.11ax (HE20)	4TX	4RX
802.11ax (HE40)	4TX	4RX
802.11ax (HE80)	4TX	4RX
802.11ax (HE160)	4TX	4RX

Note:

1. All of modulation mode support beamforming function except 802.11a modulation mode.
2. The EUT support Beamforming and CDD mode, therefore both mode were investigated and the worst case scenario was identified. The worst case data were presented in test report.
3. The modulation and bandwidth are similar for 802.11n mode for 20 MHz (40 MHz), 802.11ac mode for 20 MHz (40 MHz, 80 MHz, 160 MHz) and 802.11ax mode for 20 MHz (40MHz, 80MHz, 160 MHz), therefore the manufacturer will control the power for 802.11n/ac mode is the same as the 802.11ax or more lower than it and investigated worst case to representative mode in test report.

3.3 Channel List

FOR 5250 ~ 5320MHz

4 channels are provided for 802.11a, 802.11n (HT20), 802.11ac (VHT20), 802.11ax (HE20):

Channel	Frequency	Channel	Frequency
52	5260 MHz	60	5300 MHz
56	5280 MHz	64	5320 MHz

2 channels are provided for 802.11n (HT40), 802.11ac (VHT40), 802.11ax (HE40):

Channel	Frequency	Channel	Frequency
54	5270 MHz	62	5310 MHz

1 channel is provided for 802.11ac (VHT80), 802.11ax (HE80):

Channel	Frequency
58	5290 MHz

1 straddle channel is provided for 802.11ac (VHT160), 802.11ax (HE160):

Channel	Frequency
50	5250 MHz

FOR 5500 ~ 5720MHz

12 channels are provided for 802.11a, 802.11n (HT20), 802.11ac (VHT20), 802.11ax (HE20):

Channel	Frequency	Channel	Frequency
100	5500 MHz	124	5620 MHz
104	5520 MHz	128	5640 MHz
108	5540 MHz	132	5660 MHz
112	5560 MHz	136	5680 MHz
116	5580 MHz	140	5700 MHz
120	5600 MHz	144	5720 MHz

6 channels are provided for 802.11n (HT40), 802.11ac (VHT40), 802.11ax (HE40):

Channel	Frequency	Channel	Frequency
102	5510 MHz	126	5630 MHz
110	5550 MHz	134	5670 MHz
118	5590 MHz	142	5710 MHz

3 channels are provided for 802.11ac (VHT80), 802.11ax (HE80):

Channel	Frequency	Channel	Frequency
106	5530 MHz	138	5690 MHz
122	5610 MHz		

1 channel is provided for 802.11ac (VHT160), 802.11ax (HE160):

Channel	Frequency
114	5570 MHz

3.4 Power Setting

Power Setting								
Channel	802.11a CDD	802.11ac (VHT20) CDD	Channel	802.11ac (VHT40) CDD	Channel	802.11ac (VHT80) CDD	Channel	802.11ac (VHT160) CDD
52	17.5	17	54	17	58	13	50	13
60	17.5	17	62	17.5	106	15	114	17.5
64	17.5	17	102	17.5	122	17		
100	17.5	17.5	110	17.5	138	18		
116	16	16.5	134	18				
140	18	18	142	18.5				
144	18	18						

Power Setting							
Channel	802.11ax (HE20) CDD	Channel	802.11ax (HE40) CDD	Channel	802.11ax (HE80) CDD	Channel	802.11ax (HE160) CDD
52	17	54	17	58	13	50	13
60	17	62	17.5	106	15	114	17.5
64	17	102	17.5	122	17		
100	17.5	110	17.5	138	18		
116	16.5	134	18				
140	18	142	18.5				
144	18						

Power Setting							
Channel	802.11ac (VHT20) Beamforming	Channel	802.11ac (VHT40) Beamforming	Channel	802.11ac (VHT80) Beamforming	Channel	802.11ac (VHT160) Beamforming
52	17	54	16.5	58	13	50	13
60	17	62	17	106	15	114	16.5
64	17	102	17	122	16.5		
100	17.5	110	17	138	17.5		
116	16.5	134	17.5				
140	18	142	18				
144	18						

Power Setting							
Channel	802.11ax (HE20) Beamforming	Channel	802.11ax (HE40) Beamforming	Channel	802.11ax (HE80) Beamforming	Channel	802.11ax (HE160) Beamforming
52	17	54	16.5	58	13	50	13
60	17	62	17	106	15	114	16.5
64	17	102	17	122	16.5		
100	17.5	110	17	138	17.5		
116	16.5	134	17.5				
140	18	142	18				
144	18						

3.5 Test Mode Applicability and Tested Channel Detail

Worst Case:	1. Pre-Scan has been conducted to determine the worst-case mode from all possible combinations between available modulations, data rates and antenna ports (if EUT with antenna diversity architecture).
-------------	--

Note: Partial RU (resource unit) configurations not supported.

Following channel(s) was (were) selected for the final test as listed below:

Test Item	Mode	Signal Mode	Tested Channel	Modulation	Data Rate Parameter
26 dB Bandwidth / Power Spectral Density	802.11a	CDD	52, 60, 64, 100, 116, 140, 144	BPSK	6Mb/s
	802.11ax (HE20)	CDD	52, 60, 64, 100, 116, 140, 144	BPSK	MCS0
	802.11ax (HE40)	CDD	54, 62, 102, 110, 134, 142	BPSK	MCS0
	802.11ax (HE80)	CDD	58, 106, 122, 138	BPSK	MCS0
	802.11ax (HE160)	CDD	50, 114	BPSK	MCS0
RF Output Power	802.11a	CDD	52, 60, 64, 100, 116, 140, 144	BPSK	6Mb/s
	802.11ax (HE20)	CDD & Beamforming	52, 60, 64, 100, 116, 140, 144	BPSK	MCS0
	802.11ax (HE40)	CDD & Beamforming	54, 62, 102, 110, 134, 142	BPSK	MCS0
	802.11ax (HE80)	CDD & Beamforming	58, 106, 122, 138	BPSK	MCS0
	802.11ax (HE160)	CDD & Beamforming	50, 114	BPSK	MCS0
Occupied Bandwidth	802.11a	CDD	52, 60, 64, 100, 116, 140, 144	BPSK	6Mb/s
	802.11ax (HE20)	CDD	52, 60, 64, 100, 116, 140, 144	BPSK	MCS0
	802.11ax (HE40)	CDD	54, 62, 102, 110, 134, 142	BPSK	MCS0
	802.11ax (HE80)	CDD	58, 106, 122, 138	BPSK	MCS0
	802.11ax (HE160)	CDD	50, 114	BPSK	MCS0
Frequency Stability	802.11a	-	52	un-modulation	-
AC Power Conducted Emissions	802.11ax (HE20)	CDD	64	BPSK	MCS0
Unwanted Emissions below 1 GHz	802.11ax (HE20)	CDD	64	BPSK	MCS0
Unwanted Emissions above 1 GHz	802.11a	CDD	52, 60, 64, 100, 116, 140, 144	BPSK	6Mb/s
	802.11ax (HE20)	CDD	52, 60, 64, 100, 116, 140, 144	BPSK	MCS0
	802.11ax (HE40)	CDD	54, 62, 102, 110, 134, 142	BPSK	MCS0
	802.11ax (HE80)	CDD	58, 106, 122, 138	BPSK	MCS0
	802.11ax (HE160)	CDD	50, 114	BPSK	MCS0

3.6 Duty Cycle of Test Signal

Duty cycle of test signal is $\geq 98\%$, duty factor is not required.
 Duty cycle of test signal is $< 98\%$, duty factor shall be considered.

- 802.11a:** Duty cycle = $2.991 \text{ ms} / 3.052 \text{ ms} \times 100\% = 98.0\%$
- 802.11ax (HE20):** Duty cycle = $3.165 \text{ ms} / 3.225 \text{ ms} \times 100\% = 98.1\%$
- 802.11ax (HE40):** Duty cycle = $4.71 \text{ ms} / 4.773 \text{ ms} \times 100\% = 98.7\%$
- 802.11ax (HE80):** Duty cycle = $4.505 \text{ ms} / 4.585 \text{ ms} \times 100\% = 98.3\%$
- 802.11ax (HE160):** Duty cycle = $4.503 \text{ ms} / 4.58 \text{ ms} \times 100\% = 98.3\%$



3.7 Test Program Used and Operation Descriptions

Controlling software (QATool_Ulv2.88_DLLv6.93_ap_2022.01.04(V14)c) has been activated to set the EUT under transmission condition continuously at specific channel frequency.

3.8 Connection Diagram of EUT and Peripheral Devices

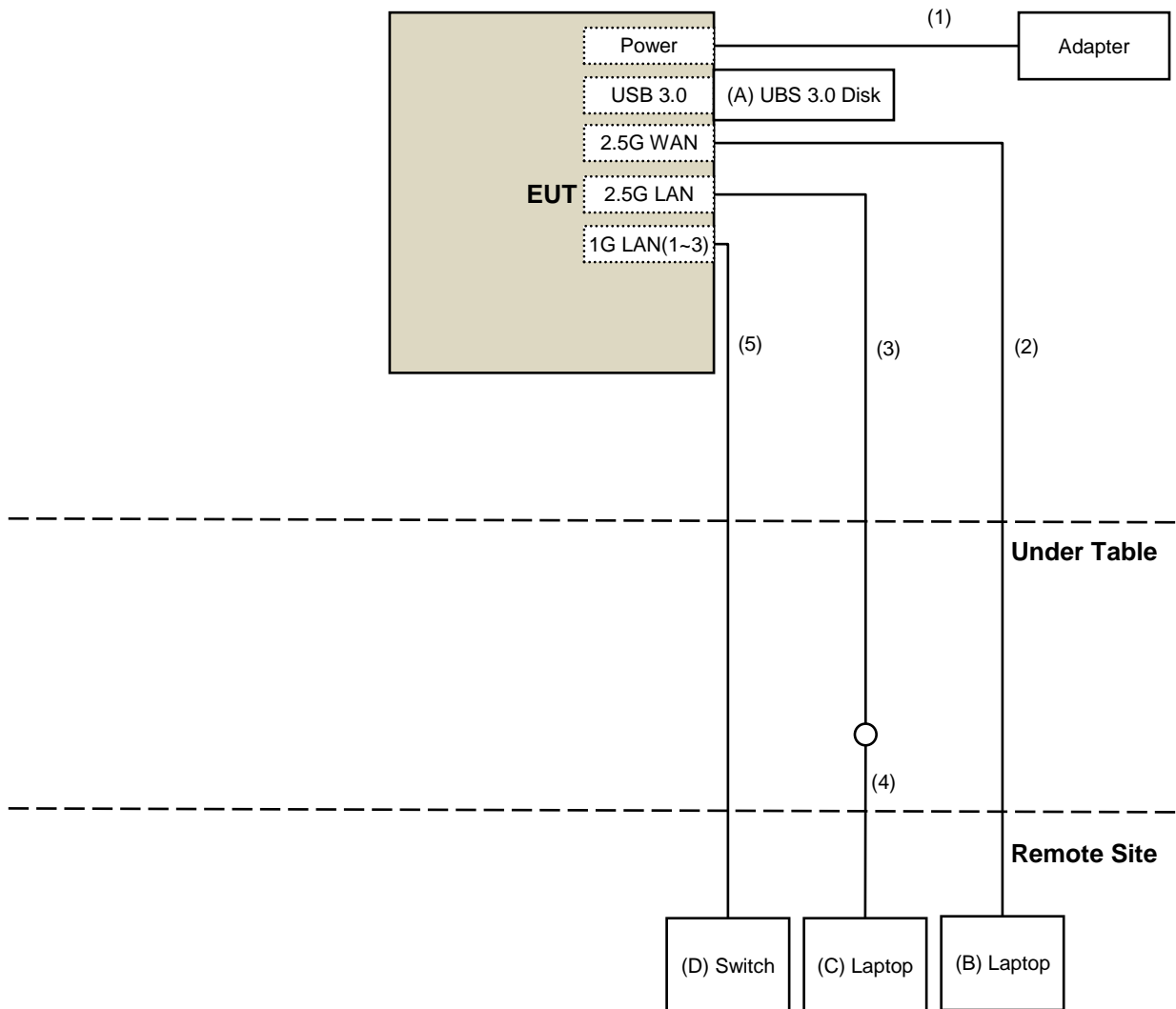

3.9 Configuration of Peripheral Devices and Cable Connections

ID	Product	Brand	Model No.	Serial No.	FCC ID	Remarks
A	UBS 3.0 Disk	SanDisk	BM181225896Z	N/A	N/A	Provided by Lab
B	Laptop	Lenovo	20U5S01X00 L14	PF-28LKK7	N/A	Provided by Lab
C	Laptop	DELL	PP36S	25733582128	N/A	Provided by Lab
D	Switch	D-Link	DGS-1005D	DR8WC92000523	N/A	Provided by Lab

ID	Cable Descriptions	Qty.	Length (m)	Shielding (Yes/No)	Cores (Qty.)	Remarks
1	DC Cable	1	1.5	No	0	Provided by Lab
2	RJ-45 Cable	1	10	No	0	Provided by Lab
3	Ethernet Cable	1	1	No	0	Supplied by applicant
4	RJ-45 Cable	1	10	No	0	Provided by Lab
5	RJ-45 Cable	3	10	No	0	Provided by Lab

4 Test Instruments

The calibration interval of the all test instruments are 12 months and the calibrations are traceable to NML/ROC and NIST/USA.

4.1 26 dB Bandwidth

Description Manufacturer	Model No.	Serial No.	Calibrated Date	Calibrated Until
Attenuator WOKEN	MDCS18N-10	MDCS18N-10-01	2022/4/5	2023/4/4
Software	ADT_RF Test Software V6.6.5.4	N/A	N/A	N/A
Spectrum Analyzer R&S	FSV40	101516	2022/3/7	2023/3/6

Notes:

1. The test was performed in Oven room 2.
2. Tested Date: 2022/7/18

4.2 RF Output Power

Description Manufacturer	Model No.	Serial No.	Calibrated Date	Calibrated Until
Attenuator WOKEN	MDCS18N-10	MDCS18N-10-01	2022/4/5	2023/4/4
Power Meter Anritsu	ML2495A	1529002	2022/6/22	2023/6/21
Pulse Power Sensor Anritsu	MA2411B	1726434	2022/6/22	2023/6/21
Software	ADT_RF Test Software V6.6.5.4	N/A	N/A	N/A
Spectrum Analyzer R&S	FSV40	101516	2022/3/7	2023/3/6

Notes:

1. The test was performed in Oven room 2.
2. Tested Date: 2022/7/18

4.3 Power Spectral Density

Refer to section 4.1 to get information of the instruments.

4.4 Occupied Bandwidth

Refer to section 4.1 to get information of the instruments.

4.5 Frequency Stability

Description Manufacturer	Model No.	Serial No.	Calibrated Date	Calibrated Until
AC Power Source GOOD WILL	6905S	1991551	N/A	N/A
Attenuator WOKEN	MDCS18N-10	MDCS18N-10-01	2022/4/5	2023/4/4
Software	ADT_RF Test Software V6.6.5.4	N/A	N/A	N/A
Spectrum Analyzer R&S	FSV40	101516	2022/3/7	2023/3/6
Temperature & Humidity Chamber Giant Force	GTH-150-40-SP-AR	MAA0812-008	2022/1/14	2023/1/13
True RMS Clamp Meter Fluke	325	31130711WS	2022/6/9	2023/6/8

Notes:

1. The test was performed in Oven room 2.
2. Tested Date: 2022/7/18

4.6 AC Power Conducted Emissions

Description Manufacturer	Model No.	Serial No.	Calibrated Date	Calibrated Until
50 ohms Terminator	50	3	2021/10/27	2022/10/26
Fixed attenuator STI	STI02-2200-10	005	2021/8/27	2022/8/26
LISN R&S	ESH3-Z5	848773/004	2021/10/29	2022/10/28
RF Coaxial Cable JYEBO	5D-FB	COCCAB-001	2021/9/25	2022/9/24
Software BVADT	BVADT_Cond_V7.3.7.4	N/A	N/A	N/A
TEST RECEIVER R&S	ESCS 30	847124/029	2021/10/13	2022/10/12

Notes:

1. The test was performed in Conduction 1
2. Tested Date: 2022/6/10

4.7 Unwanted Emissions below 1 GHz

Description Manufacturer	Model No.	Serial No.	Calibrated Date	Calibrated Until
Antenna Tower & Turn Table Max-Full	MF-7802	MF780208406	N/A	N/A
Fixed attenuator Mini-Circuits	UNAT-5+	PAD-3m-3-01	2021/9/23	2022/9/22
LOOP ANTENNA Electro-Metrics	EM-6879	264	2022/3/18	2023/3/17
Pre_Amplifier Agilent	8447D	2944A10636	2022/3/19	2023/3/18
Pre_Amplifier Mini-Circuits	ZFL-1000VH2	QA0838008	2021/10/19	2022/10/18
RF Coaxial Cable JYEBO	5D-FB	LOOPCAB-001	2022/1/6	2023/1/5
		LOOPCAB-002	2022/1/6	2023/1/5
RF Coaxial Cable COMMATE/PEWC	8D	966-4-1	2022/3/8	2023/3/7
		966-3-2	2022/2/26	2023/2/25
		966-3-3	2022/2/26	2023/2/25
Software	ADT_Radiated_V8.7.08	N/A	N/A	N/A
Spectrum Analyzer KEYSIGHT	N9030B	MY57142938	2022/4/26	2023/4/25
Test Receiver KEYSIGHT	N9038A	MY59050100	2022/6/20	2023/6/19
Trilog Broadband Antenna Schwarzbeck	VULB 9168	9168-361	2021/10/26	2022/10/25

Notes:

1. The test was performed in 966 Chamber No. 3.
2. Tested Date: 2022/7/23

4.8 Unwanted Emissions above 1 GHz

For Bandedge test:

Description Manufacturer	Model No.	Serial No.	Calibrated Date	Calibrated Until
Antenna Tower & Turn Table Max-Full	MF-7802	MF780208406	N/A	N/A
Fix tool for Boresight antenna tower BV	FBA-01	FBA_SIP01	N/A	N/A
Horn Antenna Schwarzbeck	BBHA9120-D	9120D-406	2021/11/14	2022/11/13
	BBHA 9170	9170-739	2021/11/14	2022/11/13
MXE EMI Receiver(20 Hz to 44 GHz) Keysight	N9038A	MY54450088	2021/7/6	2022/7/5
Pre_Amplifier EMCI	EMC12630SE	980384	2022/1/10	2023/1/9
	EMC184045SE	980387	2022/1/10	2023/1/9
RF Cable EMCI	EMC104-SM-SM-6000	210201	2022/5/10	2023/5/9
RF Cable-Frequency range: 1- 40GHz EMCI	EMC102-KM-KM-1200	160924	2022/1/10	2023/1/9
RF Coaxial Cable EMCI	EMC104-SM-SM-1500	180504	2022/4/25	2023/4/24
	EMC104-SM-SM-2000	180601	2022/6/6	2023/6/5
	EMC-KM-KM-4000	200214	2022/3/8	2023/3/7
Software	ADT_Radiated_V8.7.08	N/A	N/A	N/A
Spectrum Analyzer KEYSIGHT	N9030B	MY57142938	2022/4/26	2023/4/25
Test Receiver KEYSIGHT	N9038A	MY51210202	2021/11/19	2022/11/18

Notes:

1. The test was performed in 966 Chamber No. 3.
2. Tested Date: 2022/6/7 ~ 2022/6/10

For other test items:

Description Manufacturer	Model No.	Serial No.	Calibrated Date	Calibrated Until
Antenna Tower & Turn Table Max-Full	MF-7802	MF780208406	N/A	N/A
Fix tool for Boresight antenna tower BV	FBA-01	FBA_SIP01	N/A	N/A
Horn Antenna Schwarzbeck	BBHA9120-D	9120D-406	2021/11/14	2022/11/13
	BBHA 9170	9170-739	2021/11/14	2022/11/13
MXE EMI Receiver(20 Hz to 44 GHz) Keysight	N9038A	MY54450088	2022/7/13	2023/7/12
Pre_Amplifier EMCI	EMC12630SE	980384	2022/1/10	2023/1/9
	EMC184045SE	980387	2022/1/10	2023/1/9
RF Cable EMCI	EMC104-SM-SM-6000	210201	2022/5/10	2023/5/9
RF Cable-Frequency range: 1- 40GHz EMCI	EMC102-KM-KM-1200	160924	2022/1/10	2023/1/9
RF Coaxial Cable EMCI	EMC104-SM-SM-1500	180504	2022/4/25	2023/4/24
	EMC104-SM-SM-2000	180601	2022/6/6	2023/6/5
	EMC-KM-KM-4000	200214	2022/3/8	2023/3/7
Software	ADT_Radiated_V8.7.08	N/A	N/A	N/A
Spectrum Analyzer KEYSIGHT	N9030B	MY57142938	2022/4/26	2023/4/25
Test Receiver KEYSIGHT	N9038A	MY59050100	2022/6/20	2023/6/19

Notes:

1. The test was performed in 966 Chamber No. 3.
2. Tested Date: 2022/7/13 ~ 2022/7/23

5 Limits of Test Items

5.1 26 dB Bandwidth

The results are for reference only.

5.2 RF Output Power

Operation Band	EUT Category	Limit
U-NII-1	Outdoor Access Point	1 Watt (30 dBm) (Max. e.i.r.p \leq 125mW(21 dBm) at any elevation angle above 30 degrees as measured from the horizon)
	Fixed point-to-point Access Point	1 Watt (30 dBm)
	Indoor Access Point	1 Watt (30 dBm)
	Mobile and Portable client device	250mW (24 dBm)

Operation Band	Limit
U-NII-2A	250mW (24 dBm) or 11 dBm+10 log B*
U-NII-2C	250mW (24 dBm) or 11 dBm+10 log B*
U-NII-3	1 Watt (30 dBm)

*B is the 26 dB emission bandwidth in megahertz

Per KDB 662911 D01 Multiple Transmitter Output Method of conducted output power measurement on IEEE 802.11 devices,

Array Gain = 0 dB (i.e., no array gain) for $N_{ANT} \leq 4$;

Array Gain = 0 dB (i.e., no array gain) for channel widths ≥ 40 MHz for any N_{ANT} ;

Array Gain = $5 \log(N_{ANT}/N_{SS})$ dB or 3 dB, whichever is less, for 20-MHz channel widths with $N_{ANT} \geq 5$.

For power measurements on all other devices: Array Gain = $10 \log(N_{ANT}/N_{SS})$ dB.

5.3 Power Spectral Density

Operation Band	EUT Category	Limit
U-NII-1	Outdoor Access Point	17 dBm/ MHz
	Fixed point-to-point Access Point	
	Indoor Access Point	
	Mobile and Portable client device	11 dBm/ MHz

Operation Band	Limit
U-NII-2A	11 dBm/ MHz
U-NII-2C	11 dBm/ MHz
U-NII-3	30 dBm/ 500 kHz

5.4 Occupied Bandwidth

The results are for reference only.

5.5 Frequency Stability

The frequency of the carrier signal shall be maintained within band of operation.

5.6 AC Power Conducted Emissions

Frequency (MHz)	Conducted Limit (dBuV)	
	Quasi-peak	Average
0.15 - 0.5	66 - 56	56 - 46
0.50 - 5.0	56	46
5.0 - 30.0	60	50

Notes:

1. The lower limit shall apply at the transition frequencies.
2. The limit decreases in line with the logarithm of the frequency in the range of 0.15 to 0.50 MHz.

5.7 Unwanted Emissions below 1 GHz

Radiated emissions which fall in the restricted bands must comply with the radiated emission limits specified as below table.

Frequencies (MHz)	Field Strength (microvolts/meter)	Measurement Distance (meters)
0.009 ~ 0.490	2400/F(kHz)	300
0.490 ~ 1.705	24000/F(kHz)	30
1.705 ~ 30.0	30	30
30 ~ 88	100	3
88 ~ 216	150	3
216 ~ 960	200	3
Above 960	500	3

Notes:

1. The lower limit shall apply at the transition frequencies.
2. Emission level (dBuV/m) = 20 log Emission level (uV/m).

5.8 Unwanted Emissions above 1 GHz

Radiated emissions which fall in the restricted bands must comply with the radiated emission limits specified as below table.

Frequencies (MHz)	Field Strength (microvolts/meter)	Measurement Distance (meters)
Above 960	500	3

Notes:

1. The lower limit shall apply at the transition frequencies.
2. Emission level (dBuV/m) = 20 log Emission level (uV/m).
3. For frequencies above 1000 MHz, the field strength limits are based on average detector, however, the peak field strength of any emission shall not exceed the maximum permitted average limits, specified above by more than 20 dB under any condition of modulation.

Limits of unwanted emission out of the restricted bands

Applicable To		Limit	
789033 D02 General UNII Test Procedure New Rules v02r01		Field Strength at 3 m	
		PK: 74 (dBµV/m)	AV: 54 (dBµV/m)
Frequency Band	Applicable To	EIRP Limit	Equivalent Field Strength at 3 m
5150~5250 MHz	15.407(b)(1)	PK: -27 (dBm/MHz)	PK: 68.2 (dBµV/m)
5250~5350 MHz	15.407(b)(2)		
5470~5725 MHz	15.407(b)(3)		
5725~5850 MHz	15.407(b)(4)(i)	PK: -27 (dBm/MHz) ^{*1} PK: 10 (dBm/MHz) ^{*2} PK: 15.6 (dBm/MHz) ^{*3} PK: 27 (dBm/MHz) ^{*4}	PK: 68.2 (dBµV/m) ^{*1} PK: 105.2 (dBµV/m) ^{*2} PK: 110.8 (dBµV/m) ^{*3} PK: 122.2 (dBµV/m) ^{*4}
*1 beyond 75 MHz or more above of the band edge.		*2 below the band edge increasing linearly to 10 dBm/MHz at 25 MHz above.	
*3 below the band edge increasing linearly to a level of 15.6 dBm/MHz at 5 MHz above.		*4 from 5 MHz above or below the band edge increasing linearly to a level of 27 dBm/MHz at the band edge.	

Note: The following formula is used to convert the equipment isotropic radiated power (eirp) to field strength:

$$E = \frac{1000000\sqrt{30P}}{3} \mu\text{V/m, where P is the eirp (Watts).}$$

6 Test Arrangements

6.1 26 dB Bandwidth

6.1.1 Test Setup

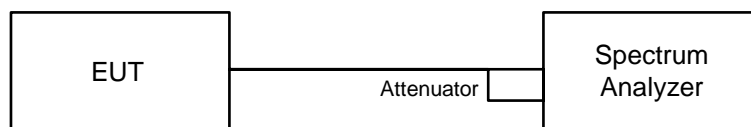

6.1.2 Test Procedure

- Set RBW = approximately 1% of the emission bandwidth.
- Set the VBW > RBW.
- Detector = Peak.
- Trace mode = max hold.
- Measure the maximum width of the emission that is 26 dB down from the peak of the emission. Compare this with the RBW setting of the analyzer. Readjust RBW and repeat measurement as needed until the RBW/EBW ratio is approximately 1%.

6.2 RF Output Power

6.2.1 Test Setup

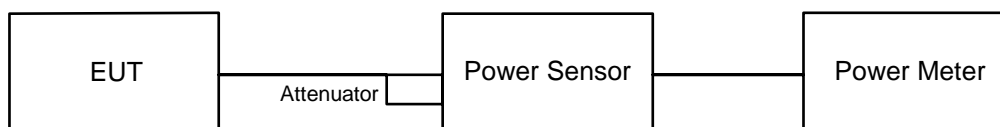

For channel straddling:

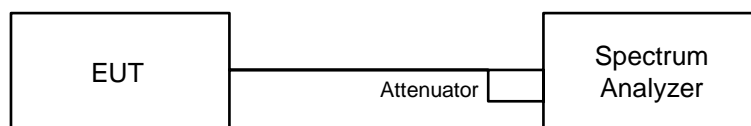

6.2.2 Test Procedure

Method PM is used to perform output power measurement, trigger and gating function of wide band power meter is enabled to measure max output power of TX on burst and set the detector to average. Duty factor is not added to measured value.

For channel straddling:

Method SA-1

- Set span to encompass the entire emission bandwidth (EBW) of the signal.
- Set RBW = 1 MHz, Set VBW ≥ 3 MHz, Detector = RMS
- Sweep points ≥ $[2 \times \text{span} / \text{RBW}]$. (This gives bin-to-bin spacing ≤ RBW / 2, so that narrowband signals are not lost between frequency bins.)
- Sweep time = auto, trigger set to “free run”.
- Trace average at least 100 traces in power averaging mode.
- Record the max value

Note: When measuring straddle channel power, use compute power by integrating the spectrum across the 26 dB EBW or 99% OBW of the signal using the instrument’s band power measurement function, with band limits set equal to the EBW or OBW band edges. If the instrument does not have a band power function, then sum the spectrum levels (in power units) at 1 MHz intervals extending across the 26 dB EBW or 99% OBW of the spectrum.

6.3 Power Spectral Density

6.3.1 Test Setup

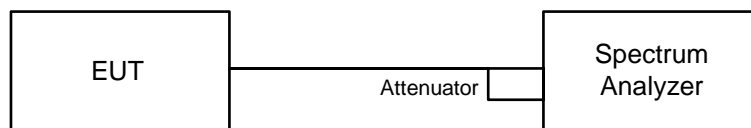

6.3.2 Test Procedure

For specified measurement bandwidth 1 MHz:

Method SA-1

- Set span to encompass the entire emission bandwidth (EBW) of the signal.
- Set RBW = 1 MHz, Set VBW \geq 3 MHz, Detector = RMS
- Sweep points \geq $[2 \times \text{span} / \text{RBW}]$. (This gives bin-to-bin spacing \leq RBW / 2, so that narrowband signals are not lost between frequency bins.)
- Sweep time = auto, trigger set to "free run".
- Trace average at least 100 traces in power averaging mode.
- Record the max value

For specified measurement bandwidth 500 kHz:

Method SA-1

- Set span to encompass the entire emission bandwidth (EBW) of the signal.
- Set RBW = 300 kHz, Set VBW \geq 1 MHz, Detector = RMS
- Scale the observed power level to an equivalent value in 500 kHz by adjusting (increasing) the measured power by a bandwidth correction factor (BWCF) where $\text{BWCF} = 10\log(500 \text{ kHz}/300 \text{ kHz})$
- Sweep points \geq $[2 \times \text{span} / \text{RBW}]$. (This gives bin-to-bin spacing \leq RBW / 2, so that narrowband signals are not lost between frequency bins.)
- Sweep time = auto, trigger set to "free run".
- Trace average at least 100 traces in power averaging mode.
- Record the max value

6.4 Occupied Bandwidth

6.4.1 Test Setup

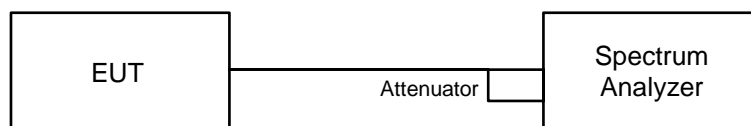

6.4.2 Test Procedure

The transmitter output was connected to the spectrum analyzer through an attenuator. The bandwidth of the fundamental frequency was measured by spectrum analyzer with resolution bandwidth in the range of 1% to 5% of the anticipated emission bandwidth, and a video bandwidth at least 3x the resolution bandwidth and set the detector to Sampling. The width of a frequency band such that, below the lower and above the upper frequency limits, the mean powers emitted are each equal to a specified percentage 0.5% of the total mean power of a given emission.

6.5 Frequency Stability

6.5.1 Test Setup

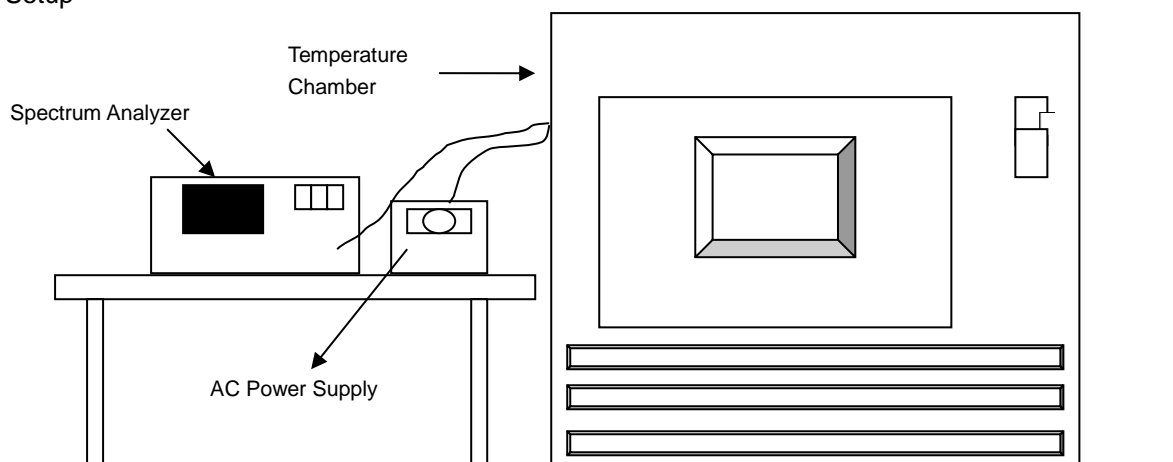

6.5.2 Test Procedure

- a. The EUT was placed inside the environmental test chamber and powered by nominal AC voltage.
- b. Turn the EUT on and couple its output to a spectrum analyzer.
- c. Turn the EUT off and set the chamber to the highest temperature specified.
- d. Allow sufficient time (approximately 30 min) for the temperature of the chamber to stabilize, turn the EUT on and measure the operating frequency after 2, 5, and 10 Minutes.
- e. Repeat step (d) with the temperature chamber set to the next desired temperature until measurements down to the lowest specified temperature have been completed.
- f. The test chamber was allowed to stabilize at +20 degree C for a minimum of 30 Minutes. The supply voltage was then adjusted on the EUT from 85% to 115% and the frequency record.

6.6 AC Power Conducted Emissions

6.6.1 Test Setup

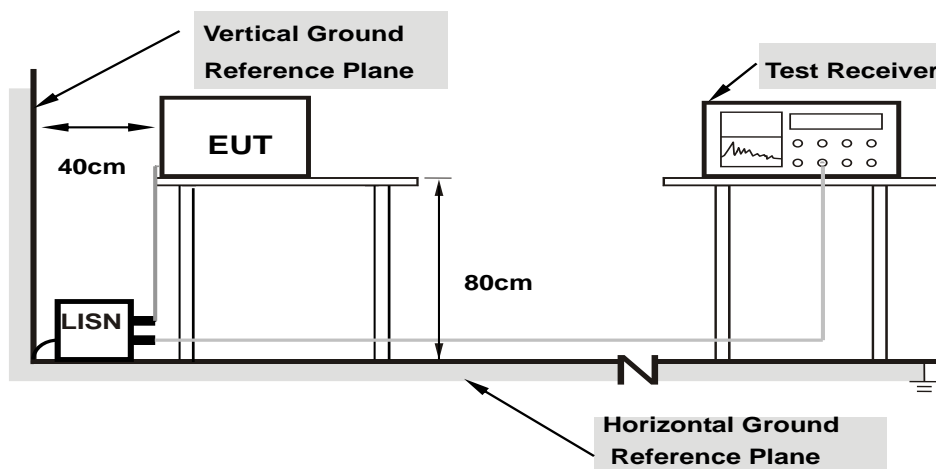

Note: 1. Support units were connected to second LISN.

For the actual test configuration, please refer to the attached file (Test Setup Photo).

6.6.2 Test Procedure

- The EUT was placed on a 0.8 meter to the top of table and placed 0.4 meters from the conducting wall of the shielded room with EUT being connected to the power mains through a line impedance stabilization network (LISN). Other support units were connected to the power mains through another LISN. The two LISNs provide 50 ohm/ 50 uH of coupling impedance for the measuring instrument.
- Both lines of the power mains connected to the EUT were checked for maximum conducted interference.
- The frequency range from 150 kHz to 30 MHz was searched. Emission levels under (Limit – 20 dB) was not recorded.

Note: The resolution bandwidth and video bandwidth of test receiver is 9 kHz for quasi-peak detection (QP) and average detection (AV) at frequency 0.15 MHz-30 MHz.

6.7 Unwanted Emissions below 1 GHz

6.7.1 Test Setup

For Radiated emission below 30 MHz

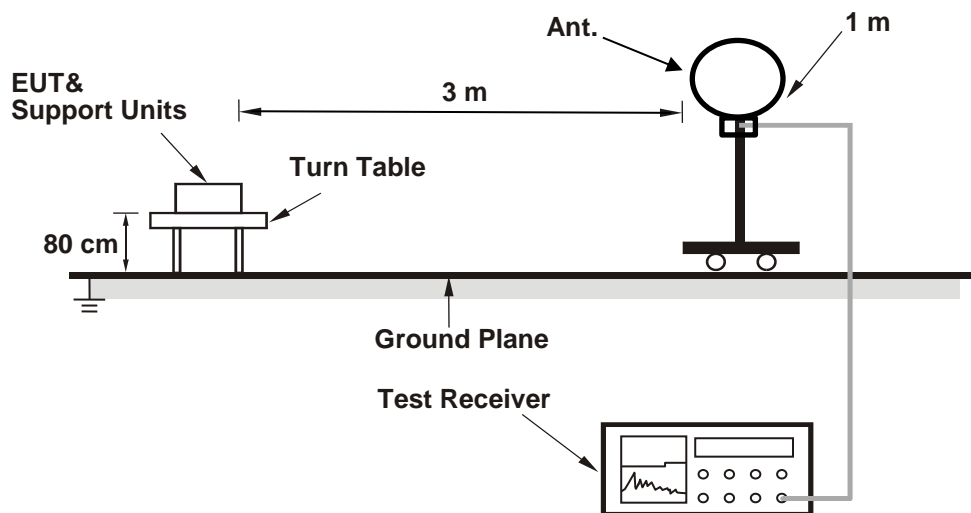

For Radiated emission above 30 MHz

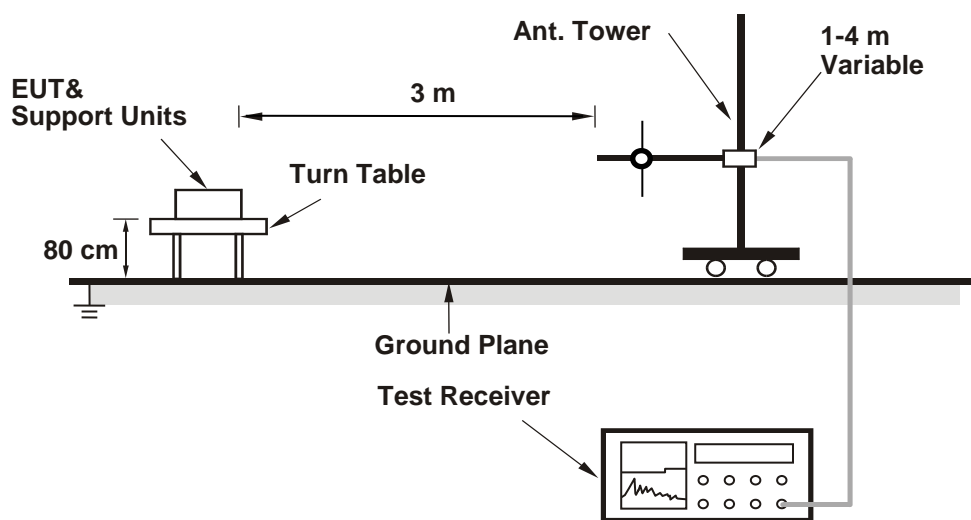

For the actual test configuration, please refer to the attached file (Test Setup Photo).

6.7.2 Test Procedure

For Radiated emission below 30 MHz

- a. The EUT was placed on the top of a rotating table 0.8 meters above the ground at 3 meter chamber room for test. The table was rotated 360 degrees to determine the position of the highest radiation.
- b. The EUT was set 3 meters away from the interference-receiving antenna, which was mounted on the top of a variable-height antenna tower.
- c. Parallel, perpendicular, and ground-parallel orientations of the antenna are set to make the measurement.
- d. For each suspected emission, the EUT was arranged to its worst case and the rotatable table was turned from 0 degrees to 360 degrees to find the maximum reading.
- e. The test-receiver system was set to Quasi-Peak Detect Function and Specified Bandwidth with Maximum Hold Mode, except for the frequency band (9 kHz to 90 kHz and 110 kHz to 490 kHz) set to average detect function and peak detect function.

Notes:

1. The resolution bandwidth and video bandwidth of test receiver/spectrum analyzer is 200 Hz at frequency below 150 kHz.
2. The resolution bandwidth and video bandwidth of test receiver/spectrum analyzer is 9 kHz or 10 kHz at frequency (150 kHz to 30 MHz).
3. All modes of operation were investigated and the worst-case emissions are reported.

For Radiated emission above 30 MHz

- a. The EUT was placed on the top of a rotating table 0.8 meters above the ground at 3 meter chamber room for test. The table was rotated 360 degrees to determine the position of the highest radiation.
- b. The EUT was set 3 meters away from the interference-receiving antenna, which was mounted on the top of a variable-height antenna tower.
- c. The height of antenna is varied from one meter to four meters above the ground to determine the maximum value of the field strength. Both horizontal and vertical polarizations of the antenna are set to make the measurement.
- d. For each suspected emission, the EUT was arranged to its worst case and then the antenna was tuned to heights from 1 meter to 4 meters and the rotatable table was turned from 0 degrees to 360 degrees to find the maximum reading.
- e. The test-receiver system was set to quasi-peak detect function and specified bandwidth with maximum hold mode when the test frequency is below 1 GHz.

Notes:

1. The resolution bandwidth and video bandwidth of test receiver/spectrum analyzer is 120 kHz for Quasi-peak detection (QP) at frequency below 1 GHz.
2. All modes of operation were investigated and the worst-case emissions are reported.

6.8 Unwanted Emissions above 1 GHz

6.8.1 Test Setup

For Radiated emission above 1 GHz

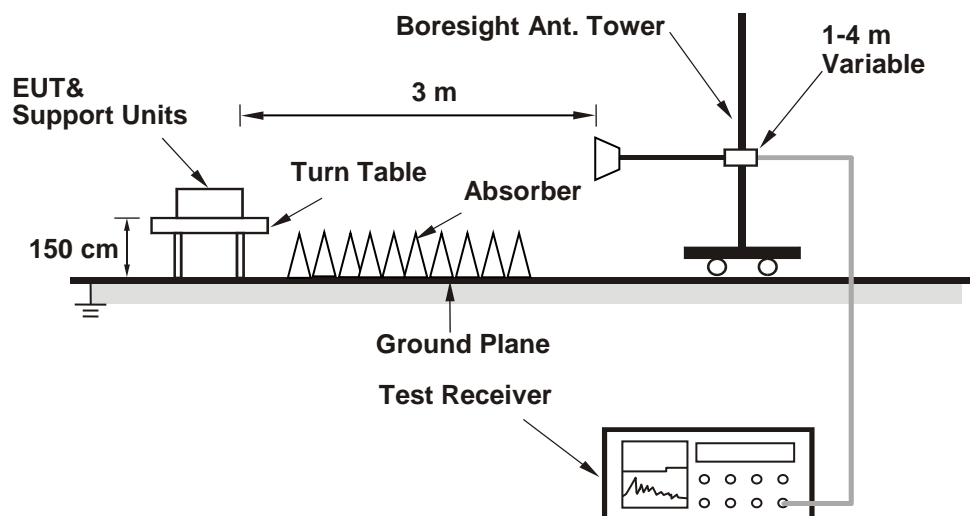

For the actual test configuration, please refer to the attached file (Test Setup Photo).

6.8.2 Test Procedure

- The EUT was placed on the top of a rotating table 1.5 meters above the ground at 3 meter chamber room for test. The table was rotated 360 degrees to determine the position of the highest radiation.
- The EUT was set 3 meters away from the interference-receiving antenna, which was mounted on the top of a variable-height antenna tower.
- The height of antenna is varied from one meter to four meters above the ground to determine the maximum value of the field strength. Both horizontal and vertical polarizations of the antenna are set to make the measurement.
- For each suspected emission, the EUT was arranged to its worst case and then the antenna was tuned to heights from 1 meter to 4 meters and the rotatable table was turned from 0 degrees to 360 degrees to find the maximum reading.
- The test-receiver system was set to peak and average detects function and specified bandwidth with maximum hold mode when the test frequency is above 1 GHz. If the peak reading value also meets average limit, measurement with the average detector is unnecessary.

Notes:

- The resolution bandwidth of test receiver/spectrum analyzer is 1 MHz and the video bandwidth is 3 MHz for Peak detection (PK) and Average detection (AV) at frequency above 1 GHz.
- For fundamental and harmonic signal measurement, the resolution bandwidth of test receiver/spectrum analyzer is 1 MHz and the video bandwidth is $\geq 1/T$ (Duty cycle < 98%) or 10 Hz (Duty cycle $\geq 98\%$) for Average detection (AV) at frequency above 1 GHz.
- All modes of operation were investigated and the worst-case emissions are reported.

7 Test Results of Test Item

7.1 26 dB Bandwidth

Input Power:	120 Vac, 60 Hz	Environmental Conditions:	25°C, 60% RH	Tested By:	Waydi Tuan
--------------	----------------	---------------------------	--------------	------------	------------

802.11a

Channel	Frequency (MHz)	26 dB Bandwidth (MHz)			
		Chain 0	Chain 1	Chain 2	Chain 3
52	5260	20.96	20.71	20.57	20.61
60	5300	25.53	23.94	25.51	24.86
64	5320	24.66	24.53	23.72	24.54
100	5500	25.04	25.49	25.63	25.74
116	5580	20.88	20.61	20.22	20.69
140	5700	23.98	23.73	23.91	22.11
144 (U-NII-2C)	5720	15.43	15.31	15.01	15.20

Determined Output Power Limit			
Channel Number	Freq.(MHz)	Min. B(MHz)	Determined Conducted Power Limit (dBm)
52	5260	20.57	24.13 > 24
60	5300	23.94	24.79 > 24
64	5320	23.72	24.75 > 24
100	5500	25.04	24.98 > 24
116	5580	20.22	24.05 > 24
140	5700	22.11	24.44 > 24
144 (U-NII-2C)	5720	15.01	22.76 < 24

Note: For U-NII-2A, U-NII-2C Band output power limitation is determined based on 26dBc bandwidth.

802.11ax (HE20)

Channel	Frequency (MHz)	26 dB Bandwidth (MHz)			
		Chain 0	Chain 1	Chain 2	Chain 3
52	5260	21.59	21.43	21.81	21.91
60	5300	23.85	22.27	23.83	24.09
64	5320	22.59	23.07	22.83	22.96
100	5500	22.87	22.38	22.43	21.98
116	5580	21.94	21.80	21.83	21.61
140	5700	22.61	22.38	22.40	22.94
144 (U-NII-2C)	5720	15.77	15.76	15.70	15.88

Determined Output Power Limit			
Channel Number	Freq.(MHz)	Min. B(MHz)	Determined Conducted Power Limit (dBm)
52	5260	21.43	24.31 > 24
60	5300	22.27	24.47 > 24
64	5320	22.59	24.53 > 24
100	5500	21.98	24.42 > 24
116	5580	21.61	24.34 > 24
140	5700	22.38	24.49 > 24
144 (U-NII-2C)	5720	15.70	22.95 < 24

Note: For U-NII-2A, U-NII-2C Band output power limitation is determined based on 26dBc bandwidth.

802.11ax (HE40)

Channel	Frequency (MHz)	26 dB Bandwidth (MHz)			
		Chain 0	Chain 1	Chain 2	Chain 3
54	5270	40.67	40.63	40.66	40.64
62	5310	43.53	45.40	42.74	43.93
102	5510	42.36	42.83	44.44	47.27
110	5550	40.71	40.69	40.73	40.68
134	5670	46.98	48.58	43.79	44.79
142 (U-NII-2C)	5710	35.30	35.30	35.42	35.30

Determined Output Power Limit			
Channel Number	Freq.(MHz)	Min. B(MHz)	Determined Conducted Power Limit (dBm)
54	5270	40.63	27.08 > 24
62	5310	42.74	27.3 > 24
102	5510	42.36	27.26 > 24
110	5550	40.68	27.09 > 24
134	5670	43.79	27.41 > 24
142 (U-NII-2C)	5710	35.30	26.47 > 24

Note: For U-NII-2A, U-NII-2C Band output power limitation is determined based on 26dBc bandwidth.

802.11ax (HE80)

Channel	Frequency (MHz)	26 dB Bandwidth (MHz)			
		Chain 0	Chain 1	Chain 2	Chain 3
58	5290	81.34	85.06	84.37	81.25
106	5530	83.49	109.46	92.00	83.49
122	5610	81.29	81.23	81.27	81.17
138 (U-NII-2C)	5690	75.46	75.68	75.30	75.44

Determined Output Power Limit			
Channel Number	Freq.(MHz)	Min. B(MHz)	Determined Conducted Power Limit (dBm)
58	5290	81.25	30.09 > 24
106	5530	83.49	30.21 > 24
122	5610	81.17	30.09 > 24
138 (U-NII-2C)	5690	75.30	29.76 > 24

Note: For U-NII-2A, U-NII-2C Band output power limitation is determined based on 26dBc bandwidth.

802.11ax (HE160)

Channel	Frequency (MHz)	26 dB Bandwidth (MHz)			
		Chain 0	Chain 1	Chain 2	Chain 3
50 (U-NII-2A)	5250	83.25	82.86	83.06	82.92
114	5570	166.80	165.74	166.74	165.81

Determined Output Power Limit			
Channel Number	Freq.(MHz)	Min. B(MHz)	Determined Conducted Power Limit (dBm)
50 (U-NII-2A)	5250	82.86	30.18 > 24
114	5570	165.74	33.19 > 24

Note: For U-NII-2A, U-NII-2C Band output power limitation is determined based on 26dBc bandwidth.

Spectrum Plot of Minimum Value

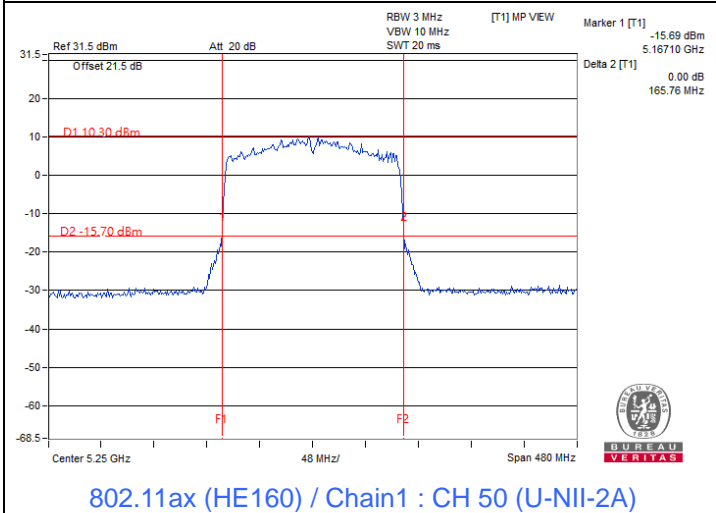
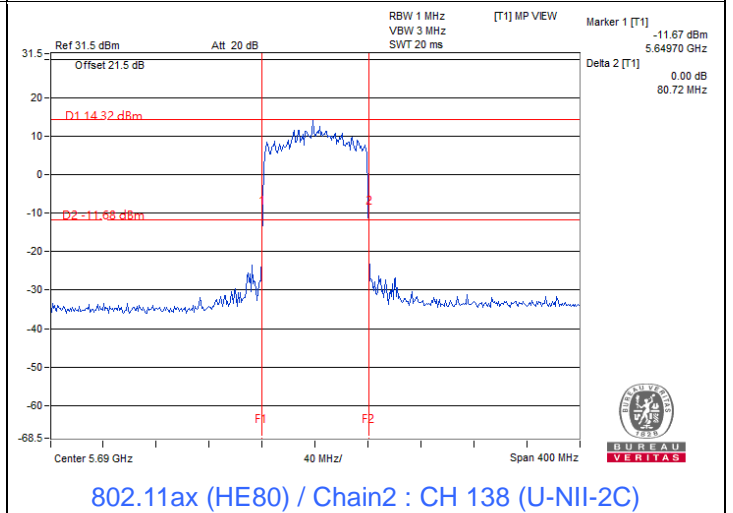
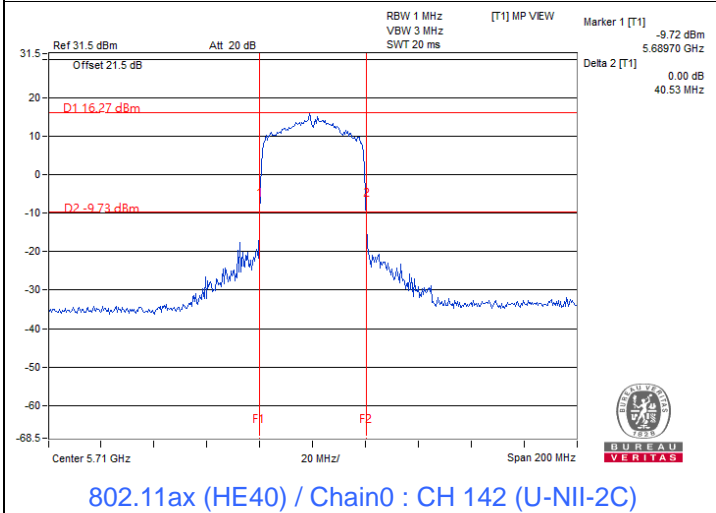
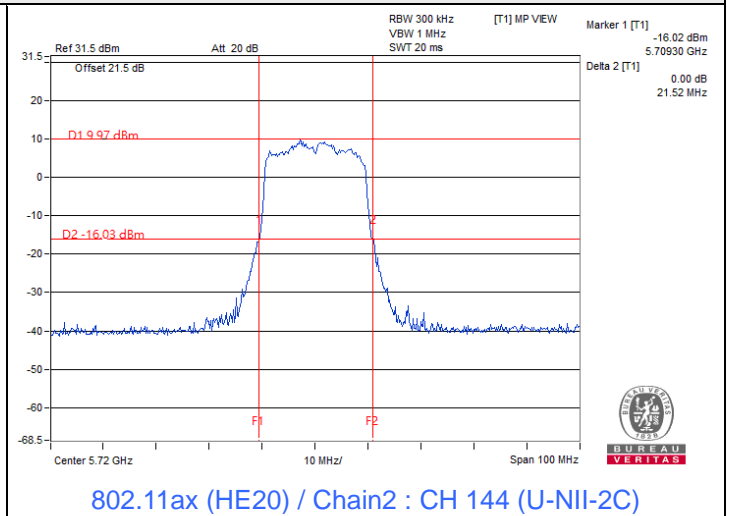
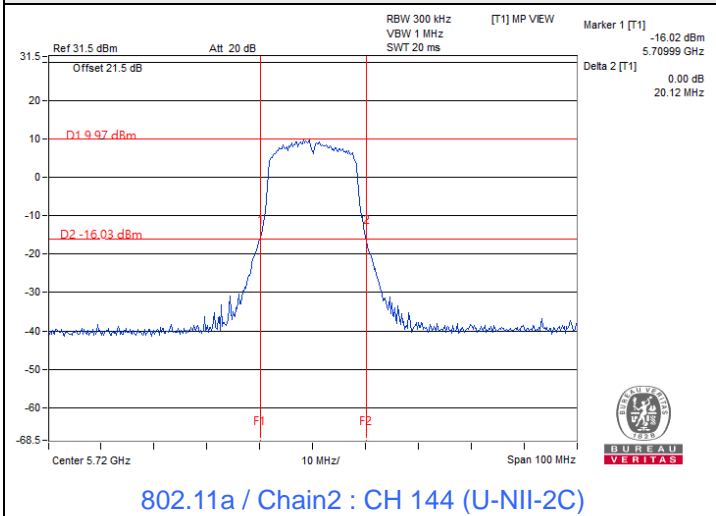

Notes:

1. For U-NII-2C straddle channel = 5725 MHz - Marker 1

7.2 RF Output Power

Input Power:	120 Vac, 60 Hz	Environmental Conditions:	25°C, 60% RH	Tested By:	Waydi Tuan
--------------	----------------	---------------------------	--------------	------------	------------

802.11a CDD

Chan.	Chan. Freq. (MHz)	Average Power (dBm)				Total Power (mW)	Total Power (dBm)	Power Limit (dBm)	Test Result
		Chain 0	Chain 1	Chain 2	Chain 3				
52	5260	17.53	17.91	17.04	16.63	215.034	23.33	24	Pass
60	5300	17.18	18.12	17.03	16.58	213.068	23.29	24	Pass
64	5320	17.15	18.32	16.89	16.53	213.644	23.30	24	Pass
100	5500	17.09	17.11	17.63	16.83	208.71	23.20	24	Pass
116	5580	16.75	17.63	16.33	17.13	199.853	23.01	24	Pass
140	5700	17.89	17.16	16.57	16.65	205.15	23.12	24	Pass
*144 (U-NII-2C)	5720	17.05	15.32	16.41	15.76	166.162	22.21	22.76	Pass
*144 (U-NII-3)	5720	9.50	8.96	8.96	7.91	30.834	14.89	30	Pass

Notes:

- * : Test was performed in accordance with measurement follow FCC KDB 789033 UNII test procedure Method SA-1 and use spectrum analyzer test.
- Directional gain is the maximum gain of antennas.
- For U-NII-2A, the directional gain is 3.8 dBi < 6 dBi, so the output power limit shall not be reduced.
- For U-NII-2C, the directional gain is 4 dBi < 6 dBi, so the output power limit shall not be reduced.
- For U-NII-3, the directional gain is 3.8 dBi < 6 dBi, so the output power limit shall not be reduced.

802.11ac (VHT20) CDD

Chan.	Chan. Freq. (MHz)	Average Power (dBm)				Total Power (mW)	Total Power (dBm)	Power Limit (dBm)	Test Result
		Chain 0	Chain 1	Chain 2	Chain 3				
52	5260	17.12	17.69	16.91	16.48	203.826	23.09	24	Pass
60	5300	16.87	17.85	16.78	16.24	199.31	23.00	24	Pass
64	5320	16.77	18.11	16.86	16.34	203.829	23.09	24	Pass
100	5500	16.68	16.64	17.03	16.24	185.229	22.68	24	Pass
116	5580	16.74	17.19	16.38	16.29	185.577	22.69	24	Pass
140	5700	17.32	16.61	16.29	16.25	184.495	22.66	24	Pass
*144 (U-NII-2C)	5720	16.09	14.86	15.54	14.82	137.413	21.38	22.95	Pass
*144 (U-NII-3)	5720	9.45	9.38	9.24	8.25	32.558	15.13	30	Pass

Notes:

- * : Test was performed in accordance with measurement follow FCC KDB 789033 UNII test procedure Method SA-1 and use spectrum analyzer test.
- Directional gain is the maximum gain of antennas.
- For U-NII-2A, the directional gain is 3.8 dBi < 6 dBi, so the output power limit shall not be reduced.
- For U-NII-2C, the directional gain is 4 dBi < 6 dBi, so the output power limit shall not be reduced.
- For U-NII-3, the directional gain is 3.8 dBi < 6 dBi, so the output power limit shall not be reduced.

802.11ac (VHT40) CDD

Chan.	Chan. Freq. (MHz)	Average Power (dBm)				Total Power (mW)	Total Power (dBm)	Power Limit (dBm)	Test Result
		Chain 0	Chain 1	Chain 2	Chain 3				
54	5270	17.58	18.08	17.25	16.77	222.17	23.47	24	Pass
62	5310	17.47	18.56	17.45	16.94	232.648	23.67	24	Pass
102	5510	17.53	17.48	17.91	16.97	224.175	23.51	24	Pass
110	5550	17.77	17.48	17.51	17.16	224.18	23.51	24	Pass
134	5670	18.11	17.86	17.60	17.19	235.713	23.72	24	Pass
*142 (U-NII-2C)	5710	17.88	17.77	17.20	16.86	222.227	23.47	24	Pass
*142 (U-NII-3)	5710	5.56	6.38	5.49	4.89	14.566	11.63	30	Pass

Notes:

- * : Test was performed in accordance with measurement follow FCC KDB 789033 UNII test procedure Method SA-1 and use spectrum analyzer test.
- Directional gain is the maximum gain of antennas.
- For U-NII-2A, the maximum gain is 3.8 dBi < 6 dBi, so the output power limit shall not be reduced.
- For U-NII-2C, the maximum gain is 4 dBi < 6 dBi, so the output power limit shall not be reduced.
- For U-NII-3, the maximum gain is 3.8 dBi < 6 dBi, so the output power limit shall not be reduced.

802.11ac (VHT80) CDD

Chan.	Chan. Freq. (MHz)	Average Power (dBm)				Total Power (mW)	Total Power (dBm)	Power Limit (dBm)	Test Result
		Chain 0	Chain 1	Chain 2	Chain 3				
58	5290	13.21	14.40	13.49	12.34	87.959	19.44	24	Pass
106	5530	15.18	15.94	15.12	14.84	135.213	21.31	24	Pass
122	5610	18.01	18.43	17.04	17.12	235.009	23.71	24	Pass
*138 (U-NII-2C)	5690	18.24	18.30	17.29	16.28	230.331	23.62	24	Pass
*138 (U-NII-3)	5690	2.47	4.35	2.47	1.02	7.52	8.76	30	Pass

Notes:

- * : Test was performed in accordance with measurement follow FCC KDB 789033 UNII test procedure Method SA-1 and use spectrum analyzer test.
- Directional gain is the maximum gain of antennas.
- For U-NII-2A, the maximum gain is 3.8 dBi < 6 dBi, so the output power limit shall not be reduced.
- For U-NII-2C, the maximum gain is 4 dBi < 6 dBi, so the output power limit shall not be reduced.
- For U-NII-3, the maximum gain is 3.8 dBi < 6 dBi, so the output power limit shall not be reduced.

802.11ac (VHT160) CDD

Chan.	Chan. Freq. (MHz)	Average Power (dBm)				Total Power (mW)	Total Power (dBm)	Power Limit (dBm)	Test Result
		Chain 0	Chain 1	Chain 2	Chain 3				
*50 (U-NII-1)	5250	8.84	10.32	10.22	9.81	38.512	15.86	30	Pass
*50 (U-NII-2A)	5250	10.23	10.03	9.80	9.33	38.733	15.88	24	Pass
114	5570	17.52	17.54	17.37	14.59	196.598	22.94	24	Pass

Notes:

- * : Test was performed in accordance with measurement follow FCC KDB 789033 UNII test procedure Method SA-1 and use spectrum analyzer test.
- Directional gain is the maximum gain of antennas.
- For U-NII-2A, the maximum gain is 3.8 dBi < 6 dBi, so the output power limit shall not be reduced.
- For U-NII-2C, the maximum gain is 4 dBi < 6 dBi, so the output power limit shall not be reduced.

802.11ax (HE20) CDD

Chan.	Chan. Freq. (MHz)	Average Power (dBm)				Total Power (mW)	Total Power (dBm)	Power Limit (dBm)	Test Result
		Chain 0	Chain 1	Chain 2	Chain 3				
52	5260	17.31	17.92	17.13	16.71	214.294	23.31	24	Pass
60	5300	17.09	18.08	17.01	16.48	210.134	23.22	24	Pass
64	5320	16.98	18.33	17.09	16.57	214.528	23.31	24	Pass
100	5500	17.22	17.19	17.57	16.76	209.655	23.22	24	Pass
116	5580	17.27	17.72	16.91	16.83	209.775	23.22	24	Pass
140	5700	17.84	17.13	16.82	16.78	208.182	23.18	24	Pass
*144 (U-NII-2C)	5720	16.09	14.86	15.54	14.82	137.413	21.38	22.95	Pass
*144 (U-NII-3)	5720	9.45	9.38	9.24	8.25	32.558	15.13	30	Pass

Notes:

- * : Test was performed in accordance with measurement follow FCC KDB 789033 UNII test procedure Method SA-1 and use spectrum analyzer test.
- Directional gain is the maximum gain of antennas.
- For U-NII-2A, the directional gain is 3.8 dBi < 6 dBi, so the output power limit shall not be reduced.
- For U-NII-2C, the directional gain is 4 dBi < 6 dBi, so the output power limit shall not be reduced.
- For U-NII-3, the directional gain is 3.8 dBi < 6 dBi, so the output power limit shall not be reduced.

802.11ax (HE40) CDD

Chan.	Chan. Freq. (MHz)	Average Power (dBm)				Total Power (mW)	Total Power (dBm)	Power Limit (dBm)	Test Result
		Chain 0	Chain 1	Chain 2	Chain 3				
54	5270	17.84	18.34	17.52	17.00	235.66	23.72	24	Pass
62	5310	17.70	18.80	17.70	17.21	246.228	23.91	24	Pass
102	5510	17.77	17.70	18.15	17.23	236.883	23.75	24	Pass
110	5550	18.00	17.72	17.75	17.39	236.646	23.74	24	Pass
134	5670	18.31	18.09	17.83	17.43	248.19	23.95	24	Pass
*142 (U-NII-2C)	5710	17.88	17.77	17.20	16.86	222.227	23.47	24	Pass
*142 (U-NII-3)	5710	5.56	6.38	5.49	4.89	14.566	11.63	30	Pass

Notes:

- * : Test was performed in accordance with measurement follow FCC KDB 789033 UNII test procedure Method SA-1 and use spectrum analyzer test.
- Directional gain is the maximum gain of antennas.
- For U-NII-2A, the maximum gain is 3.8 dBi < 6 dBi, so the output power limit shall not be reduced.
- For U-NII-2C, the maximum gain is 4 dBi < 6 dBi, so the output power limit shall not be reduced.
- For U-NII-3, the maximum gain is 3.8 dBi < 6 dBi, so the output power limit shall not be reduced.

802.11ax (HE80) CDD

Chan.	Chan. Freq. (MHz)	Average Power (dBm)				Total Power (mW)	Total Power (dBm)	Power Limit (dBm)	Test Result
		Chain 0	Chain 1	Chain 2	Chain 3				
58	5290	13.45	14.66	13.73	12.60	93.174	19.69	24	Pass
106	5530	15.43	16.20	15.38	15.08	143.326	21.56	24	Pass
122	5610	18.26	18.63	17.30	17.35	247.962	23.94	24	Pass
*138 (U-NII-2C)	5690	18.24	18.30	17.29	16.28	230.331	23.62	24	Pass
*138 (U-NII-3)	5690	2.47	4.35	2.47	1.02	7.52	8.76	30	Pass

Notes:

- * : Test was performed in accordance with measurement follow FCC KDB 789033 UNII test procedure Method SA-1 and use spectrum analyzer test.
- Directional gain is the maximum gain of antennas.
- For U-NII-2A, the maximum gain is 3.8 dBi < 6 dBi, so the output power limit shall not be reduced.
- For U-NII-2C, the maximum gain is 4 dBi < 6 dBi, so the output power limit shall not be reduced.
- For U-NII-3, the maximum gain is 3.8 dBi < 6 dBi, so the output power limit shall not be reduced.

802.11ax (HE160) CDD

Chan.	Chan. Freq. (MHz)	Average Power (dBm)				Total Power (mW)	Total Power (dBm)	Power Limit (dBm)	Test Result
		Chain 0	Chain 1	Chain 2	Chain 3				
*50 (U-NII-1)	5250	8.84	10.32	10.22	9.81	38.512	15.86	30	Pass
*50 (U-NII-2A)	5250	10.23	10.03	9.80	9.33	38.733	15.88	24	Pass
114	5570	17.76	17.80	17.60	16.83	225.698	23.54	24	Pass

Notes:

- * : Test was performed in accordance with measurement follow FCC KDB 789033 UNII test procedure Method SA-1 and use spectrum analyzer test.
- Directional gain is the maximum gain of antennas.
- For U-NII-2A, the maximum gain is 3.8 dBi < 6 dBi, so the output power limit shall not be reduced.
- For U-NII-2C, the maximum gain is 4 dBi < 6 dBi, so the output power limit shall not be reduced.

802.11ac (VHT20) Beamforming

Chan.	Chan. Freq. (MHz)	Average Power (dBm)				Total Power (mW)	Total Power (dBm)	Power Limit (dBm)	Test Result
		Chain 0	Chain 1	Chain 2	Chain 3				
52	5260	17.08	17.68	16.91	16.47	203.116	23.08	23.34	Pass
60	5300	16.86	17.85	16.78	16.25	199.295	22.99	23.34	Pass
64	5320	16.77	18.11	16.88	16.35	204.153	23.10	23.34	Pass
100	5500	17.01	16.98	17.34	16.53	199.301	23.00	23.38	Pass
116	5580	16.87	17.29	16.51	16.44	191.047	22.81	23.38	Pass
140	5700	17.43	16.84	16.48	16.42	191.957	22.83	23.38	Pass
*144 (U-NII-2C)	5720	16.09	14.86	15.54	14.82	137.413	21.38	22.33	Pass
*144 (U-NII-3)	5720	9.45	9.38	9.24	8.25	32.558	15.13	30	Pass

Notes:

- * : Test was performed in accordance with measurement follow FCC KDB 789033 UNII test procedure Method SA-1 and use spectrum analyzer test.
- Directional gain is the measured value according to KDB 662911 D03 Method of MIMO Antenna Gain Measurement.
- For U-NII-2A, the directional gain is 6.66 dBi > 6 dBi, so the output power limit shall be reduced to [Determined Conducted Power Limit-(6.66-6)].
- For U-NII-2C, the directional gain is 6.62 dBi > 6 dBi, so the output power limit shall be reduced to [Determined Conducted Power Limit-(6.62-6)].
- For U-NII-3, the directional gain is 5.57 dBi < 6 dBi, so the output power limit shall not be reduced.

802.11ac (VHT40) Beamforming

Chan.	Chan. Freq. (MHz)	Average Power (dBm)				Total Power (mW)	Total Power (dBm)	Power Limit (dBm)	Test Result
		Chain 0	Chain 1	Chain 2	Chain 3				
54	5270	17.07	17.59	16.75	16.24	197.733	22.96	23.34	Pass
62	5310	16.91	17.96	16.87	16.36	203.5	23.09	23.34	Pass
102	5510	17.03	16.95	17.39	16.48	199.302	23.00	23.38	Pass
110	5550	17.25	16.97	17.00	16.63	199.007	22.99	23.38	Pass
134	5670	17.01	17.26	17.02	16.69	200.461	23.02	23.38	Pass
*142 (U-NII-2C)	5710	17.38	17.27	16.70	16.36	198.06	22.97	23.38	Pass
*142 (U-NII-3)	5710	5.06	5.88	4.99	4.39	12.982	11.13	30	Pass

Notes:

- * : Test was performed in accordance with measurement follow FCC KDB 789033 UNII test procedure Method SA-1 and use spectrum analyzer test.
- Directional gain is the measured value according to KDB 662911 D03 Method of MIMO Antenna Gain Measurement.
- For U-NII-2A, the directional gain is 6.66 dBi > 6 dBi, so the output power limit shall be reduced to [Determined Conducted Power Limit-(6.66-6)].
- For U-NII-2C, the directional gain is 6.62 dBi > 6 dBi, so the output power limit shall be reduced to [Determined Conducted Power Limit-(6.62-6)].
- For U-NII-3, the directional gain is 5.57 dBi < 6 dBi, so the output power limit shall not be reduced.

802.11ac (VHT80) Beamforming

Chan.	Chan. Freq. (MHz)	Average Power (dBm)				Total Power (mW)	Total Power (dBm)	Power Limit (dBm)	Test Result
		Chain 0	Chain 1	Chain 2	Chain 3				
58	5290	13.21	14.40	13.49	12.34	87.959	19.44	23.34	Pass
106	5530	15.18	15.94	15.12	14.84	135.213	21.31	23.38	Pass
122	5610	17.42	17.79	16.45	16.48	203.945	23.10	23.38	Pass
*138 (U-NII-2C)	5690	17.74	17.80	16.79	15.78	205.282	23.12	23.38	Pass
*138 (U-NII-3)	5690	2.47	4.35	2.47	1.02	7.52	8.76	30	Pass

Notes:

- * : Test was performed in accordance with measurement follow FCC KDB 789033 UNII test procedure Method SA-1 and use spectrum analyzer test.
- Directional gain is the measured value according to KDB 662911 D03 Method of MIMO Antenna Gain Measurement.
- For U-NII-2A, the directional gain is 6.66 dBi > 6 dBi, so the output power limit shall be reduced to [Determined Conducted Power Limit-(6.66-6)].
- For U-NII-2C, the directional gain is 6.62 dBi > 6 dBi, so the output power limit shall be reduced to [Determined Conducted Power Limit-(6.62-6)].
- For U-NII-3, the directional gain is 5.57 dBi < 6 dBi, so the output power limit shall not be reduced.

802.11ac (VHT160) Beamforming

Chan.	Chan. Freq. (MHz)	Average Power (dBm)				Total Power (mW)	Total Power (dBm)	Power Limit (dBm)	Test Result
		Chain 0	Chain 1	Chain 2	Chain 3				
*50 (U-NII-1)	5250	8.84	10.32	10.22	9.81	38.512	15.86	29.51	Pass
*50 (U-NII-2A)	5250	10.23	10.03	9.80	9.33	38.733	15.88	23.34	Pass
114	5570	17.01	17.03	16.85	16.06	189.482	22.78	23.38	Pass

Notes:

- * : Test was performed in accordance with measurement follow FCC KDB 789033 UNII test procedure Method SA-1 and use spectrum analyzer test.
- Directional gain is the measured value according to KDB 662911 D03 Method of MIMO Antenna Gain Measurement.
- For U-NII-2A, the directional gain is 6.66 dBi > 6 dBi, so the output power limit shall be reduced to [Determined Conducted Power Limit-(6.66-6)].

802.11ax (HE20) Beamforming

Chan.	Chan. Freq. (MHz)	Average Power (dBm)				Total Power (mW)	Total Power (dBm)	Power Limit (dBm)	Test Result
		Chain 0	Chain 1	Chain 2	Chain 3				
52	5260	17.31	17.92	17.13	16.71	214.294	23.31	23.34	Pass
60	5300	17.09	18.08	17.01	16.48	210.134	23.22	23.34	Pass
64	5320	16.98	18.33	17.09	16.57	214.528	23.31	23.34	Pass
100	5500	17.22	17.19	17.57	16.75	209.546	23.21	23.38	Pass
116	5580	17.19	17.63	16.84	16.78	206.252	23.14	23.38	Pass
140	5700	17.68	17.07	16.74	16.75	204.068	23.10	23.38	Pass
*144 (U-NII-2C)	5720	16.09	14.86	15.54	14.82	137.413	21.38	22.33	Pass
*144 (U-NII-3)	5720	9.45	9.38	9.24	8.25	32.558	15.13	30	Pass

Notes:

- * : Test was performed in accordance with measurement follow FCC KDB 789033 UNII test procedure Method SA-1 and use spectrum analyzer test.
- Directional gain is the measured value according to KDB 662911 D03 Method of MIMO Antenna Gain Measurement.
- For U-NII-2A, the directional gain is 6.66 dBi > 6 dBi, so the output power limit shall be reduced to [Determined Conducted Power Limit-(6.66-6)].
- For U-NII-2C, the directional gain is 6.62 dBi > 6 dBi, so the output power limit shall be reduced to [Determined Conducted Power Limit-(6.62-6)].
- For U-NII-3, the directional gain is 5.57 dBi < 6 dBi, so the output power limit shall not be reduced.

802.11ax (HE40) Beamforming

Chan.	Chan. Freq. (MHz)	Average Power (dBm)				Total Power (mW)	Total Power (dBm)	Power Limit (dBm)	Test Result
		Chain 0	Chain 1	Chain 2	Chain 3				
54	5270	17.31	17.82	16.99	16.47	208.725	23.20	23.34	Pass
62	5310	17.14	18.18	17.09	16.59	214.298	23.31	23.34	Pass
102	5510	17.24	17.17	17.62	16.69	209.561	23.21	23.38	Pass
110	5550	17.47	17.19	17.22	16.85	209.347	23.21	23.38	Pass
134	5670	17.22	17.48	17.24	16.91	210.756	23.24	23.38	Pass
*142 (U-NII-2C)	5710	17.38	17.27	16.70	16.36	198.06	22.97	23.38	Pass
*142 (U-NII-3)	5710	5.06	5.88	4.99	4.39	12.982	11.13	30	Pass

Notes:

- * : Test was performed in accordance with measurement follow FCC KDB 789033 UNII test procedure Method SA-1 and use spectrum analyzer test.
- Directional gain is the measured value according to KDB 662911 D03 Method of MIMO Antenna Gain Measurement.
- For U-NII-2A, the directional gain is 6.66 dBi > 6 dBi, so the output power limit shall be reduced to [Determined Conducted Power Limit-(6.66-6)].
- For U-NII-2C, the directional gain is 6.62 dBi > 6 dBi, so the output power limit shall be reduced to [Determined Conducted Power Limit-(6.62-6)].
- For U-NII-3, the directional gain is 5.57 dBi < 6 dBi, so the output power limit shall not be reduced.

802.11ax (HE80) Beamforming

Chan.	Chan. Freq. (MHz)	Average Power (dBm)				Total Power (mW)	Total Power (dBm)	Power Limit (dBm)	Test Result
		Chain 0	Chain 1	Chain 2	Chain 3				
58	5290	13.45	14.66	13.73	12.60	93.174	19.69	23.34	Pass
106	5530	15.43	16.20	15.38	15.08	143.326	21.56	23.38	Pass
122	5610	17.64	18.02	16.67	16.71	214.796	23.32	23.38	Pass
*138 (U-NII-2C)	5690	17.74	17.80	16.79	15.78	205.282	23.12	23.38	Pass
*138 (U-NII-3)	5690	2.47	4.35	2.47	1.02	7.52	8.76	30	Pass

Notes:

- * : Test was performed in accordance with measurement follow FCC KDB 789033 UNII test procedure Method SA-1 and use spectrum analyzer test.
- Directional gain is the measured value according to KDB 662911 D03 Method of MIMO Antenna Gain Measurement.
- For U-NII-2A, the directional gain is 6.66 dBi > 6 dBi, so the output power limit shall be reduced to [Determined Conducted Power Limit-(6.66-6)].
- For U-NII-2C, the directional gain is 6.62 dBi > 6 dBi, so the output power limit shall be reduced to [Determined Conducted Power Limit-(6.62-6)].
- For U-NII-3, the directional gain is 5.57 dBi < 6 dBi, so the output power limit shall not be reduced.

802.11ax (HE160) Beamforming

Chan.	Chan. Freq. (MHz)	Average Power (dBm)				Total Power (mW)	Total Power (dBm)	Power Limit (dBm)	Test Result
		Chain 0	Chain 1	Chain 2	Chain 3				
*50 (U-NII-1)	5250	8.84	10.32	10.22	9.81	38.512	15.86	29.51	Pass
*50 (U-NII-2A)	5250	10.23	10.03	9.80	9.33	38.733	15.88	23.34	Pass
114	5570	17.22	17.25	17.08	16.29	199.422	23.00	23.38	Pass

Notes:

- * : Test was performed in accordance with measurement follow FCC KDB 789033 UNII test procedure Method SA-1 and use spectrum analyzer test.
- Directional gain is the measured value according to KDB 662911 D03 Method of MIMO Antenna Gain Measurement.
- For U-NII-2A, the directional gain is 6.66 dBi > 6 dBi, so the output power limit shall be reduced to [Determined Conducted Power Limit-(6.66-6)].



For channel straddling 5725MHz of Power

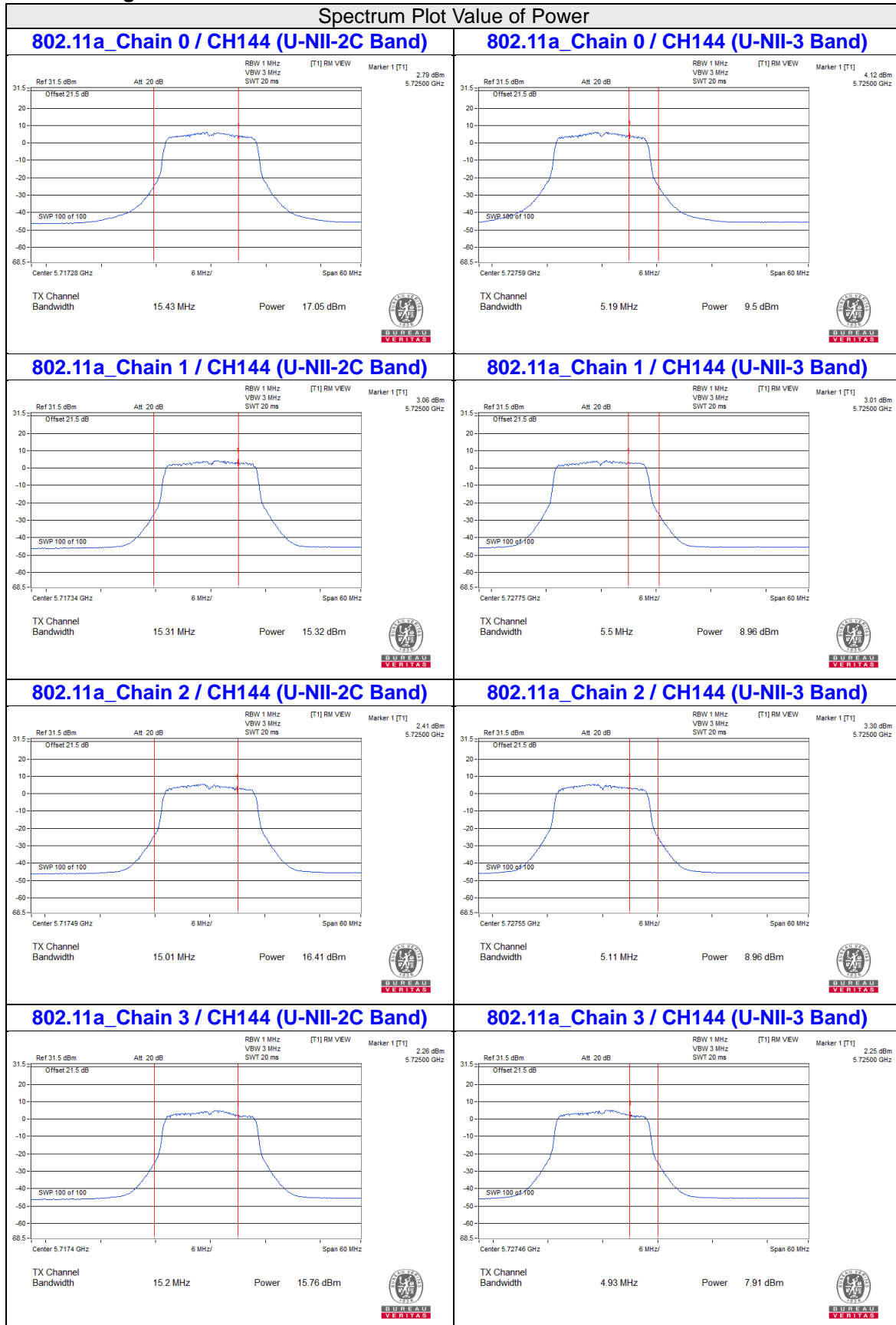





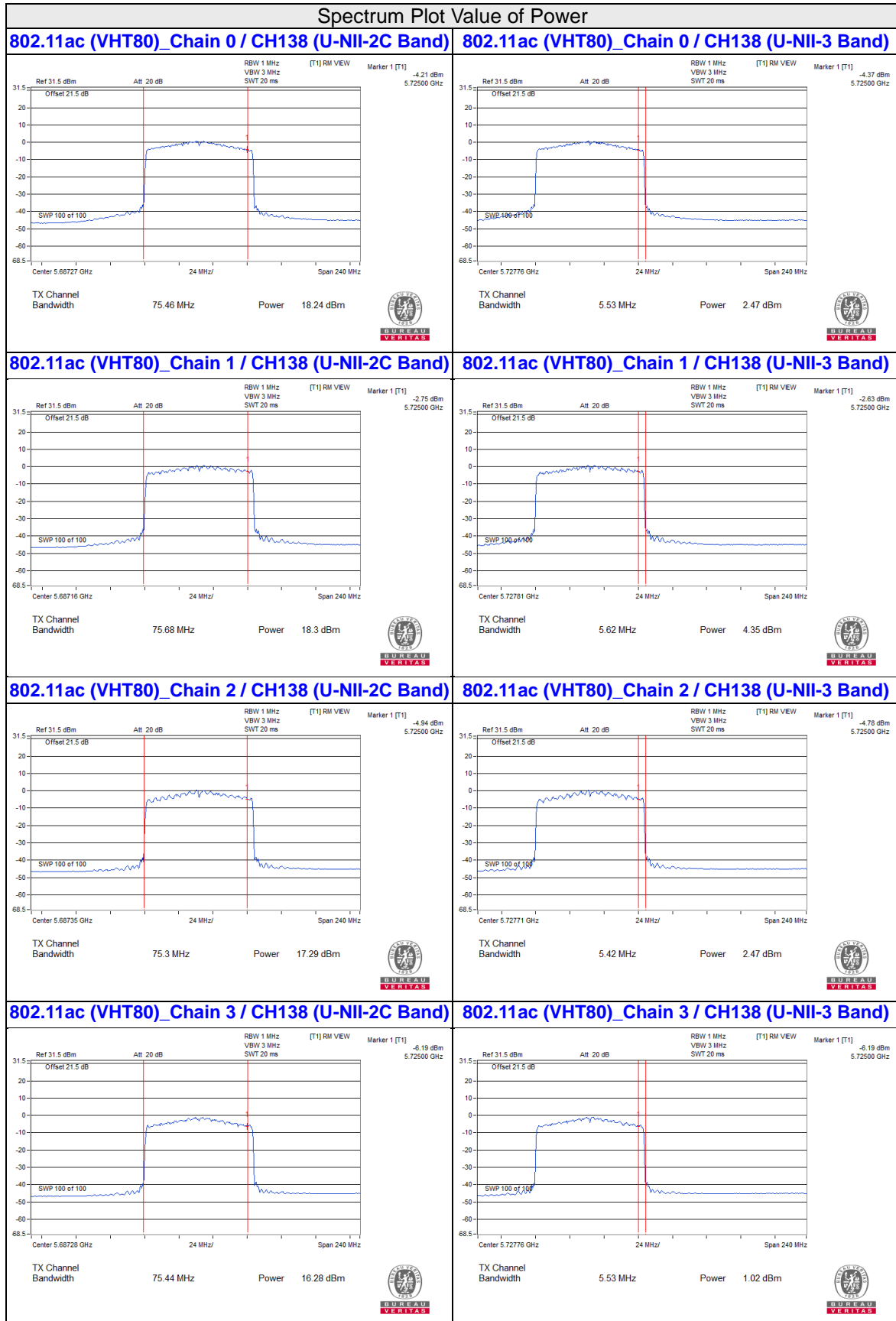

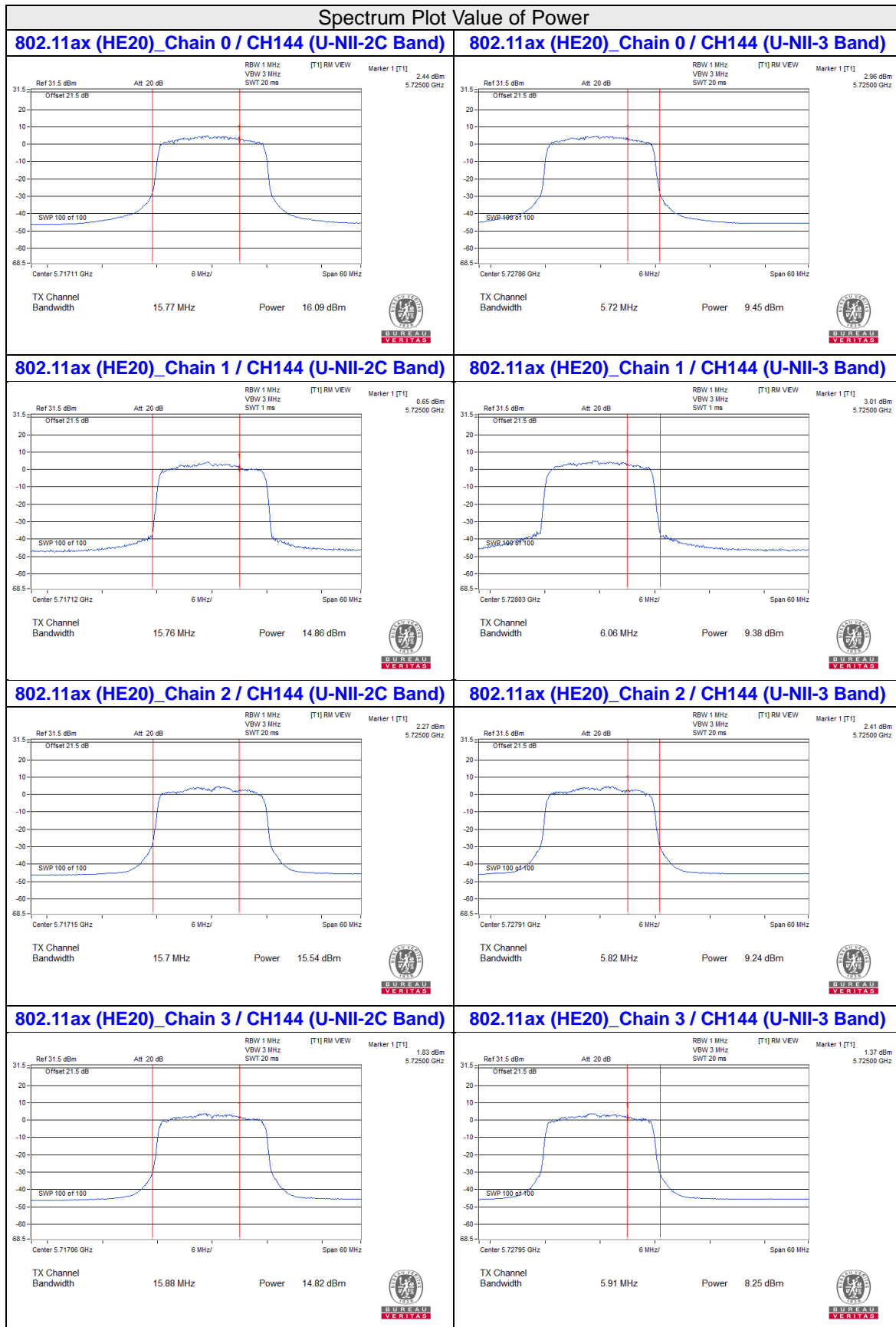

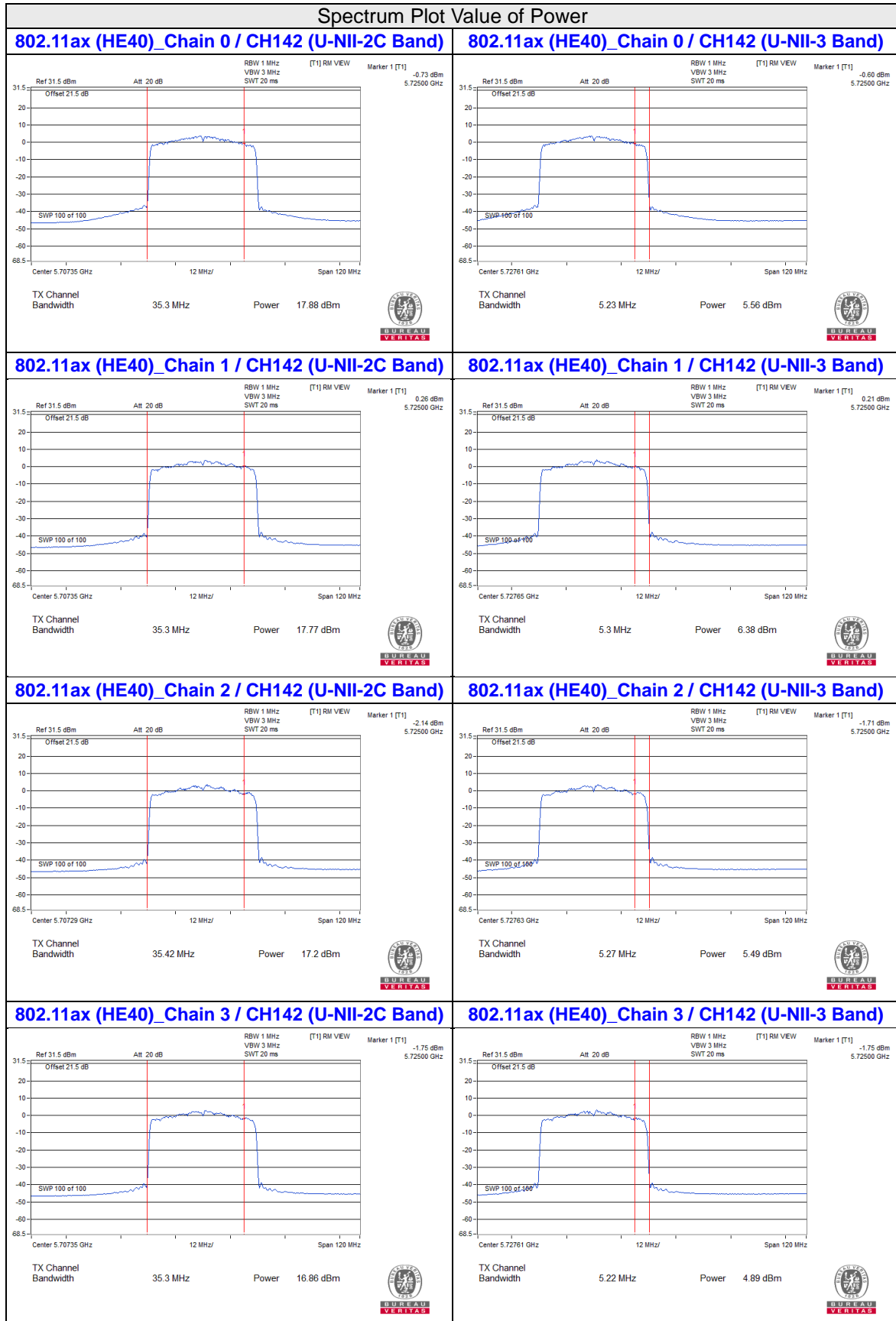

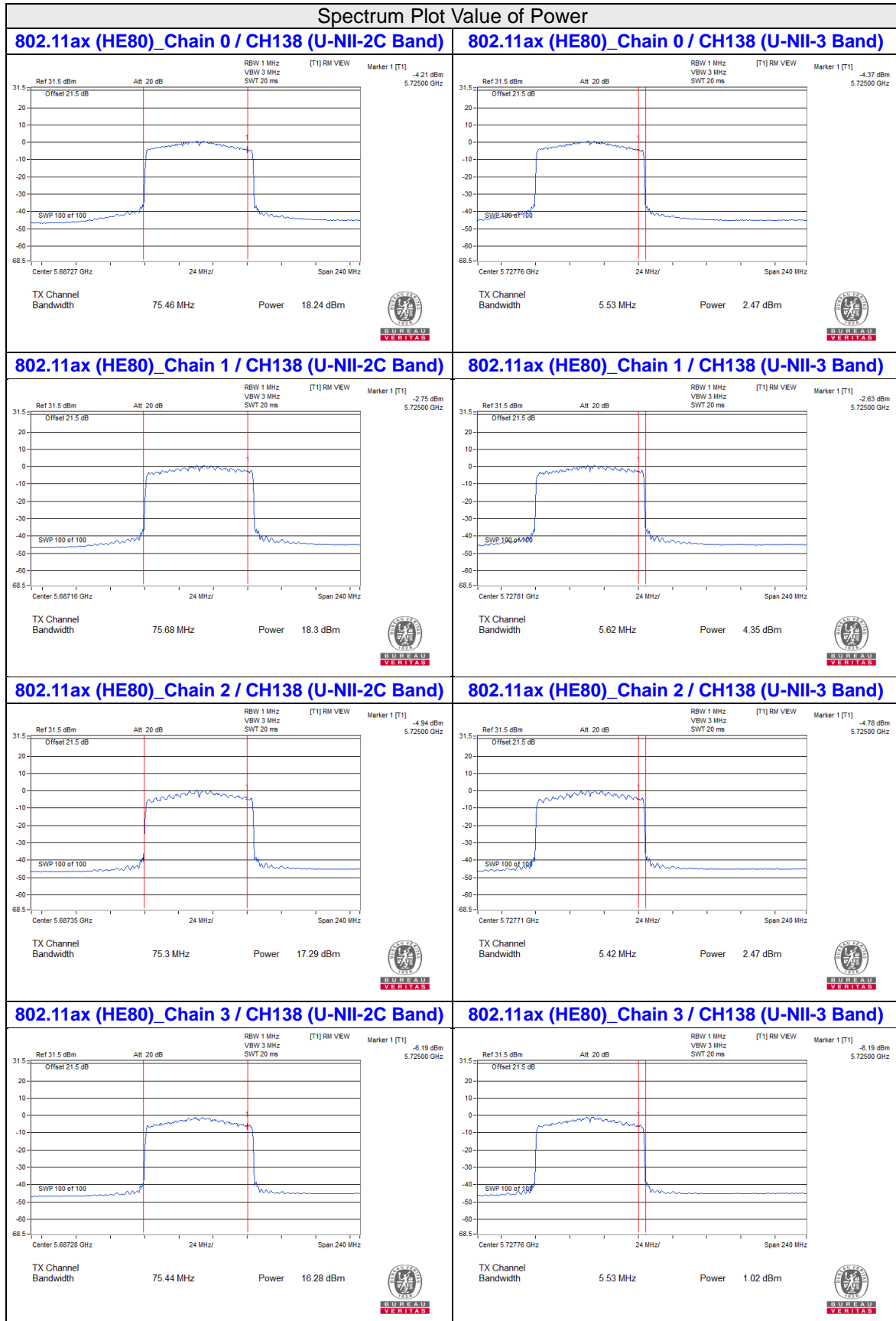



For channel straddling 5250MHz of Power





7.3 Power Spectral Density

Input Power:	120 Vac, 60 Hz	Environmental Conditions:	25°C, 60% RH	Tested By:	Waydi Tuan
--------------	----------------	---------------------------	--------------	------------	------------

802.11a

Chan.	Chan. Freq. (MHz)	PSD (dBm/MHz)				Total PSD (dBm/MHz)	Max. PSD Limit (dBm/MHz)	Test Result
		Chain 0	Chain 1	Chain 2	Chain 3			
52	5260	3.56	3.95	4.26	3.73	9.90	10.34	Pass
60	5300	3.48	4.13	4.36	3.46	9.90	10.34	Pass
64	5320	3.40	4.54	4.23	3.97	10.08	10.34	Pass
100	5500	3.82	4.04	4.51	4.01	10.12	10.38	Pass
116	5580	2.61	4.35	2.84	3.82	9.48	10.38	Pass
140	5700	4.38	3.60	3.51	4.13	9.94	10.38	Pass
144 (U-NII-2C)	5720	4.44	3.59	4.10	4.20	10.11	10.38	Pass

Notes:

- Method E) 2) a) of power density measurement of KDB 662911 is using for calculating total power density. Total power density is summing entire spectra across corresponding frequency bins on the various outputs by computer.
- Directional gain is the measured value according to KDB 662911 D03 Method of MIMO Antenna Gain Measurement.
- For U-NII-2A, the directional gain is 6.66 dBi > 6 dBi, so the power density limit shall be reduced to $11 - (6.66 - 6) = 10.34$ dBm/MHz.
- For U-NII-2C, the directional gain is 6.62 dBi > 6 dBi, so the power density limit shall be reduced to $11 - (6.62 - 6) = 10.38$ dBm/MHz.

802.11ax (HE20)

Chan.	Chan. Freq. (MHz)	PSD (dBm/MHz)				Total PSD (dBm/MHz)	Max. PSD Limit (dBm/MHz)	Test Result
		Chain 0	Chain 1	Chain 2	Chain 3			
52	5260	4.64	4.67	4.18	2.80	10.16	10.34	Pass
60	5300	4.29	4.93	4.02	2.81	10.10	10.34	Pass
64	5320	4.05	5.36	4.15	3.02	10.25	10.34	Pass
100	5500	3.88	4.50	4.63	3.77	10.23	10.38	Pass
116	5580	3.50	4.32	4.92	3.62	10.15	10.38	Pass
140	5700	4.10	5.20	4.51	3.02	10.30	10.38	Pass
144 (U-NII-2C)	5720	4.74	4.99	3.33	3.58	10.24	10.38	Pass

Notes:

- Method E) 2) a) of power density measurement of KDB 662911 is using for calculating total power density. Total power density is summing entire spectra across corresponding frequency bins on the various outputs by computer.
- Directional gain is the measured value according to KDB 662911 D03 Method of MIMO Antenna Gain Measurement.
- For U-NII-2A, the directional gain is 6.66 dBi > 6 dBi, so the power density limit shall be reduced to $11-(6.66-6) = 10.34$ dBm/MHz.
- For U-NII-2C, the directional gain is 6.62 dBi > 6 dBi, so the power density limit shall be reduced to $11-(6.62-6) = 10.38$ dBm/MHz.

802.11ax (HE40)

Chan.	Chan. Freq. (MHz)	PSD (dBm/MHz)				Total PSD (dBm/MHz)	Max. PSD Limit (dBm/MHz)	Test Result
		Chain 0	Chain 1	Chain 2	Chain 3			
54	5270	2.04	2.76	2.25	1.01	8.08	10.34	Pass
62	5310	2.20	3.47	2.69	1.24	8.49	10.34	Pass
102	5510	1.92	2.41	3.45	0.51	8.22	10.38	Pass
110	5550	2.02	1.97	3.28	1.90	8.35	10.38	Pass
134	5670	1.96	3.16	3.28	1.91	8.65	10.38	Pass
142 (U-NII-2C)	5710	3.00	3.95	3.00	2.63	9.19	10.38	Pass

Notes:

- Method E) 2) a) of power density measurement of KDB 662911 is using for calculating total power density. Total power density is summing entire spectra across corresponding frequency bins on the various outputs by computer.
- Directional gain is the measured value according to KDB 662911 D03 Method of MIMO Antenna Gain Measurement.
- For U-NII-2A, the directional gain is 6.66 dBi > 6 dBi, so the power density limit shall be reduced to $11-(6.66-6) = 10.34$ dBm/MHz.
- For U-NII-2C, the directional gain is 6.62 dBi > 6 dBi, so the power density limit shall be reduced to $11-(6.62-6) = 10.38$ dBm/MHz.

802.11ax (HE80)

Chan.	Chan. Freq. (MHz)	PSD (dBm/MHz)				Total PSD (dBm/MHz)	Max. PSD Limit (dBm/MHz)	Test Result
		Chain 0	Chain 1	Chain 2	Chain 3			
58	5290	-5.91	-3.79	-5.20	-6.66	0.76	10.34	Pass
106	5530	-3.59	-2.66	-3.30	-3.68	2.73	10.38	Pass
122	5610	0.33	-0.01	-0.40	-0.26	5.94	10.38	Pass
138 (U-NII-2C)	5690	0.74	0.90	0.42	-1.73	6.22	10.38	Pass

Notes:

- Method E) 2) a) of power density measurement of KDB 662911 is using for calculating total power density. Total power density is summing entire spectra across corresponding frequency bins on the various outputs by computer.
- Directional gain is the measured value according to KDB 662911 D03 Method of MIMO Antenna Gain Measurement.
- For U-NII-2A, the directional gain is 6.66 dBi > 6 dBi, so the power density limit shall be reduced to $11 - (6.66 - 6) = 10.34$ dBm/MHz.
- For U-NII-2C, the directional gain is 6.62 dBi > 6 dBi, so the power density limit shall be reduced to $11 - (6.62 - 6) = 10.38$ dBm/MHz.

802.11ax (HE160)

Chan.	Chan. Freq. (MHz)	PSD (dBm/MHz)				Total PSD (dBm/MHz)	Max. PSD Limit (dBm/MHz)	Test Result
		Chain 0	Chain 1	Chain 2	Chain 3			
50 (U-NII-1)	5250	-9.75	-7.56	-7.88	-8.67	-2.37	16.51	Pass
50 (U-NII-2A)	5250	-9.56	-7.63	-7.97	-8.72	-2.39	10.34	Pass
114	5570	-4.30	-3.51	-2.87	-4.37	2.30	10.38	Pass

Notes:

- Method E) 2) a) of power density measurement of KDB 662911 is using for calculating total power density. Total power density is summing entire spectra across corresponding frequency bins on the various outputs by computer.
- Directional gain is the measured value according to KDB 662911 D03 Method of MIMO Antenna Gain Measurement.
- For U-NII-2A, the directional gain is 6.66 dBi > 6 dBi, so the power density limit shall be reduced to $11 - (6.66 - 6) = 10.34$ dBm/MHz.
- For U-NII-2C, the directional gain is 6.62 dBi > 6 dBi, so the power density limit shall be reduced to $11 - (6.62 - 6) = 10.38$ dBm/MHz.

802.11a

Chan.	Chan. Freq. (MHz)	PSD (dBm/300kHz)				Total PSD (dBm/300kHz)	Total PSD (dBm/500kHz)	PSD Limit (dBm/500kHz)	Test Result
		Chain 0	Chain 1	Chain 2	Chain 3				
144 (U-NII-3)	5720	-7.32	-7.59	-5.47	-6.84	-0.7	1.52	30	Pass

Notes:

- Method E) 2) b) Measure and sum spectral maxima across the outputs of KDB 662911 is using for calculating total power density.
- Directional gain is the measured value according to KDB 662911 D03 Method of MIMO Antenna Gain Measurement.

802.11ax (HE20)

Chan.	Chan. Freq. (MHz)	PSD (dBm/300kHz)				Total PSD (dBm/300kHz)	Total PSD (dBm/500kHz)	PSD Limit (dBm/500kHz)	Test Result
		Chain 0	Chain 1	Chain 2	Chain 3				
144 (U-NII-3)	5720	-5.74	-6.19	-6.47	-7.43	-0.39	1.83	30	Pass

Notes:

1. Method E) 2) b) Measure and sum spectral maxima across the outputs of KDB 662911 is using for calculating total power density.
2. Directional gain is the measured value according to KDB 662911 D03 Method of MIMO Antenna Gain Measurement.

802.11ax (HE40)

Chan.	Chan. Freq. (MHz)	PSD (dBm/300kHz)				Total PSD (dBm/300kHz)	Total PSD (dBm/500kHz)	PSD Limit (dBm/500kHz)	Test Result
		Chain 0	Chain 1	Chain 2	Chain 3				
142 (U-NII-3)	5710	-10.08	-8.73	-10.03	-10.66	-3.79	-1.57	30	Pass

Notes:

1. Method E) 2) b) Measure and sum spectral maxima across the outputs of KDB 662911 is using for calculating total power density.
2. Directional gain is the measured value according to KDB 662911 D03 Method of MIMO Antenna Gain Measurement.

802.11ax (HE80)

Chan.	Chan. Freq. (MHz)	PSD (dBm/300kHz)				Total PSD (dBm/300kHz)	Total PSD (dBm/500kHz)	PSD Limit (dBm/500kHz)	Test Result
		Chain 0	Chain 1	Chain 2	Chain 3				
138 (U-NII-3)	5690	-13.50	-11.40	-13.33	-14.72	-7.05	-4.83	30	Pass

Notes:

1. Method E) 2) b) Measure and sum spectral maxima across the outputs of KDB 662911 is using for calculating total power density.
2. Directional gain is the measured value according to KDB 662911 D03 Method of MIMO Antenna Gain Measurement.



Spectrum Plot of Maximum Value

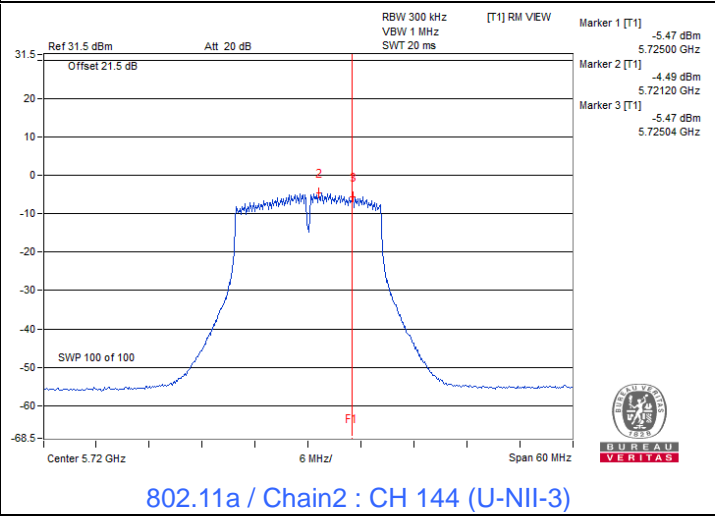
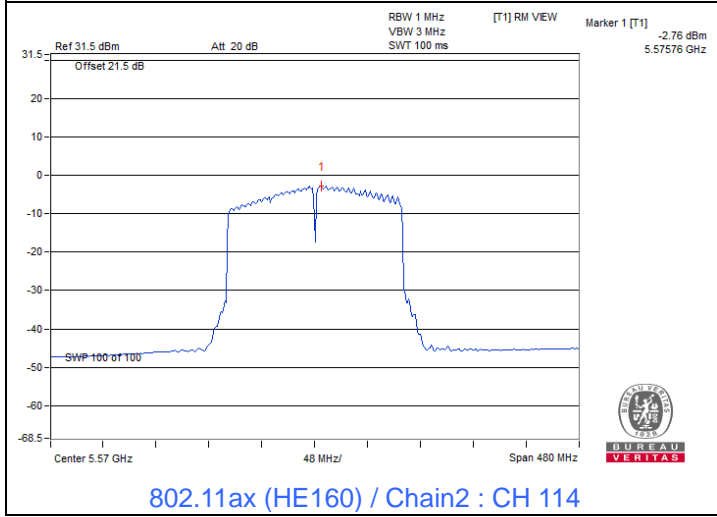
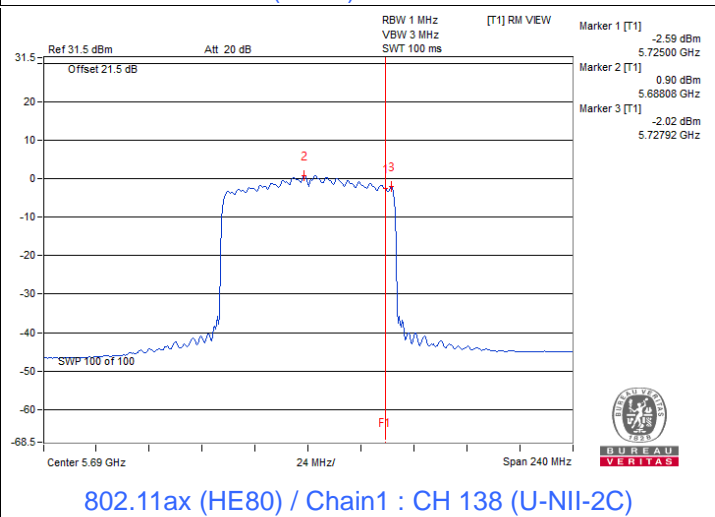
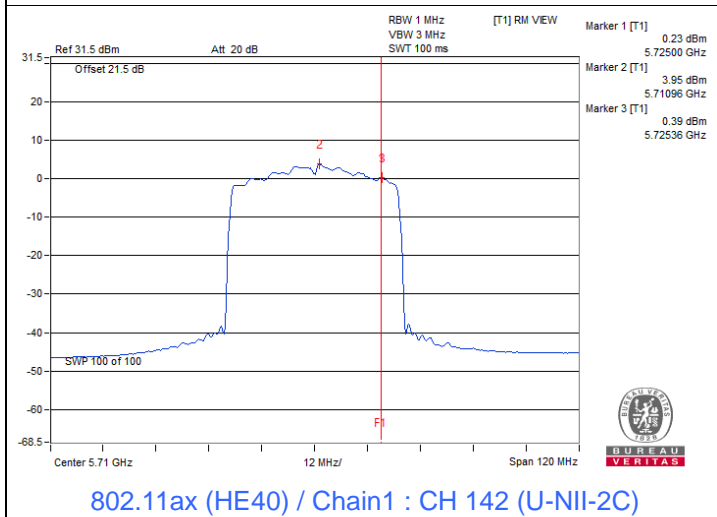
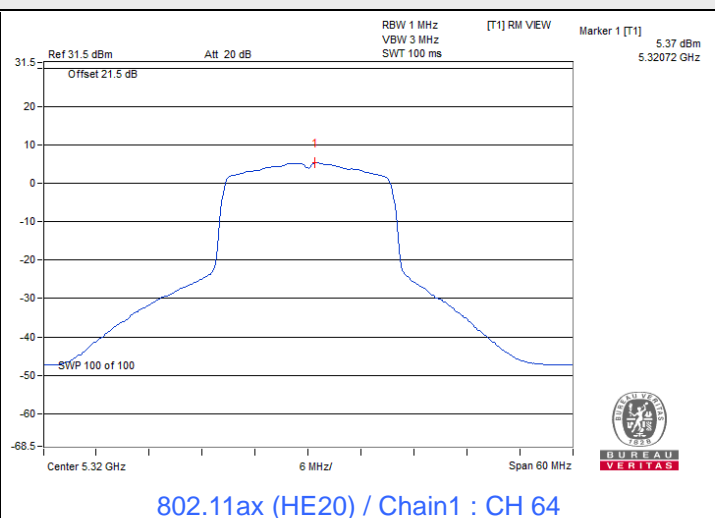
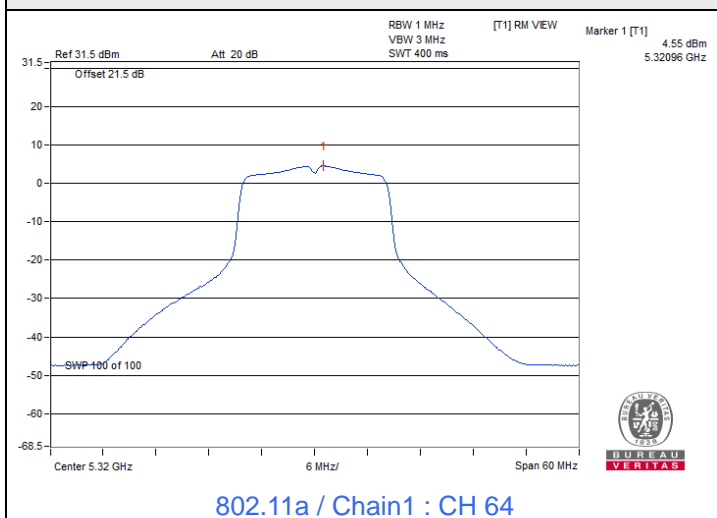

Spectrum Plot of Maximum Value

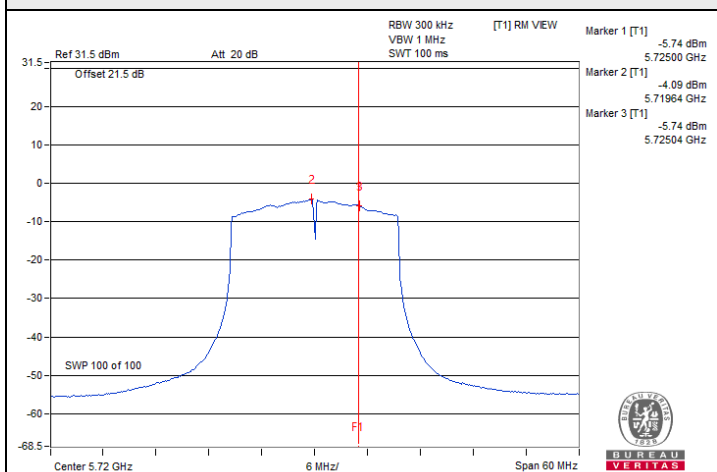

802.11ax (HE20) / Chain0 : CH 144 (U-NII-3)

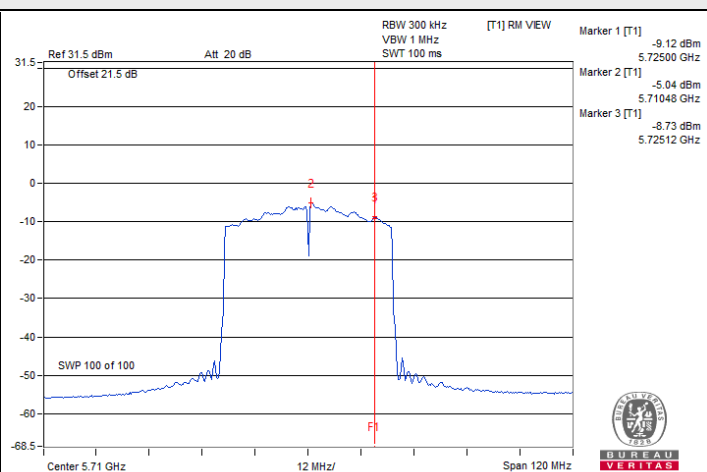

802.11ax (HE40) / Chain1 : CH 142 (U-NII-3)

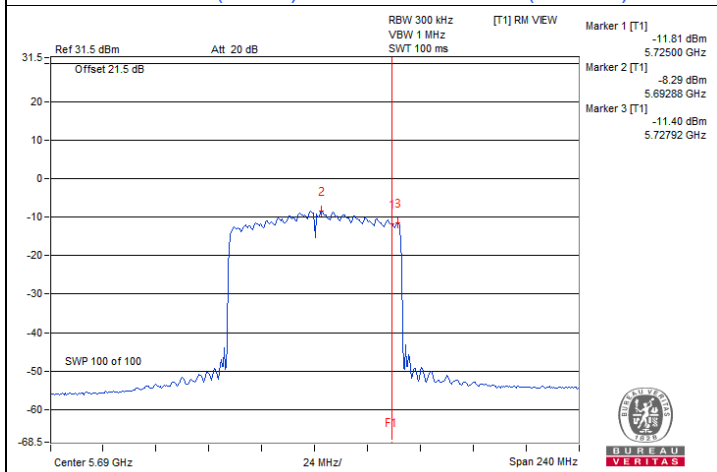

802.11ax (HE80) / Chain1 : CH 138 (U-NII-3)

7.4 Occupied Bandwidth

Input Power:	120 Vac, 60 Hz	Environmental Conditions:	25°C, 60% RH	Tested By:	Waydi Tuan
--------------	----------------	---------------------------	--------------	------------	------------

802.11a

Channel	Frequency (MHz)	Occupied Bandwidth (MHz)			
		Chain 0	Chain 1	Chain 2	Chain 3
52	5260	16.56	16.56	16.44	16.44
60	5300	16.68	16.68	16.68	16.68
64	5320	16.68	16.68	16.68	16.68
100	5500	16.80	16.68	16.68	16.68
116	5580	16.56	16.56	16.44	16.44
140	5700	16.68	16.68	16.44	16.56
144 (U-NII-2C)	5720	13.28	13.28	13.28	13.28
144 (U-NII-3)	5720	3.16	3.28	3.16	3.16

802.11ax (HE20)

Channel	Frequency (MHz)	Occupied Bandwidth (MHz)			
		Chain 0	Chain 1	Chain 2	Chain 3
52	5260	18.96	18.96	18.96	18.84
60	5300	18.96	19.08	18.96	18.96
64	5320	18.96	18.96	18.96	19.08
100	5500	18.96	18.96	19.08	18.96
116	5580	18.84	18.84	18.96	18.84
140	5700	19.08	18.96	18.96	18.84
144 (U-NII-2C)	5720	14.48	14.48	14.48	14.48
144 (U-NII-3)	5720	4.36	4.48	4.36	4.36

802.11ax (HE40)

Channel	Frequency (MHz)	Occupied Bandwidth (MHz)			
		Chain 0	Chain 1	Chain 2	Chain 3
54	5270	37.56	37.56	37.44	37.56
62	5310	37.56	37.56	37.80	37.68
102	5510	37.68	37.68	37.68	37.80
110	5550	37.44	37.68	37.68	37.44
134	5670	37.68	37.68	37.68	37.68
142 (U-NII-2C)	5710	33.72	33.72	33.96	33.96
142 (U-NII-3)	5710	3.72	3.72	3.72	3.72

802.11ax (HE80)

Channel	Frequency (MHz)	Occupied Bandwidth (MHz)			
		Chain 0	Chain 1	Chain 2	Chain 3
58	5290	76.80	77.04	77.04	76.80
106	5530	76.80	76.80	76.80	76.80
122	5610	76.56	77.04	77.04	76.80
138 (U-NII-2C)	5690	73.88	73.40	73.40	73.40
138 (U-NII-3)	5690	3.40	3.40	3.40	3.40

802.11ax (HE160)

Channel	Frequency (MHz)	Occupied Bandwidth (MHz)			
		Chain 0	Chain 1	Chain 2	Chain 3
50 (U-NII-1)	5250	77.76	77.76	77.76	77.76
50 (U-NII-2A)	5250	78.72	76.80	77.76	77.76
114	5570	155.52	155.52	154.56	155.52

Spectrum Plot of Maximum Value

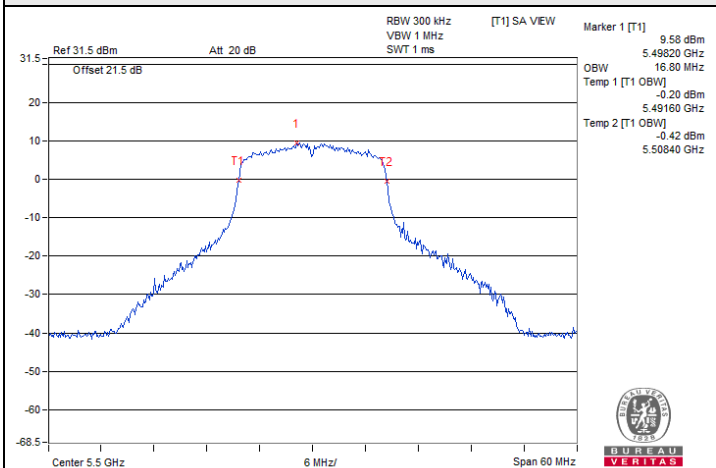

802.11a / Chain0 : CH 100

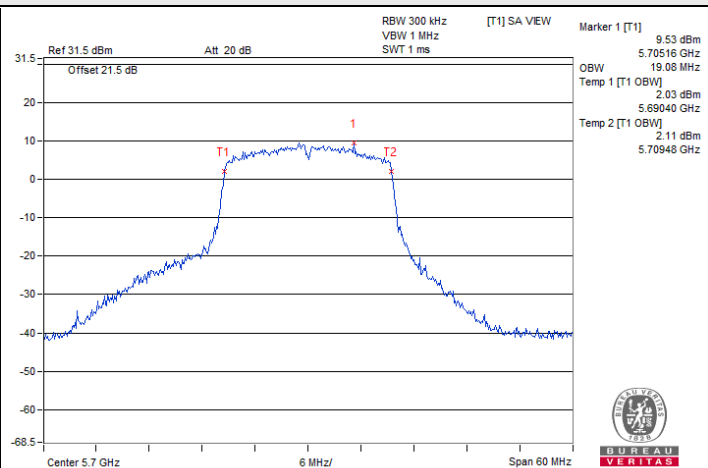

802.11ax (HE20) / Chain0 : CH 140

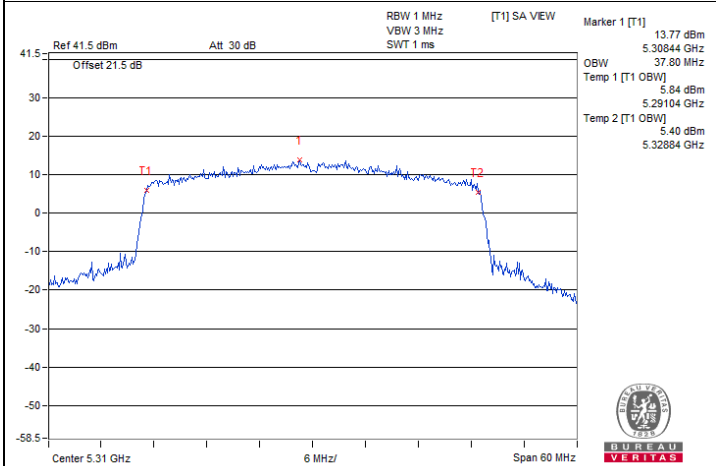

802.11ax (HE40) / Chain2 : CH 62

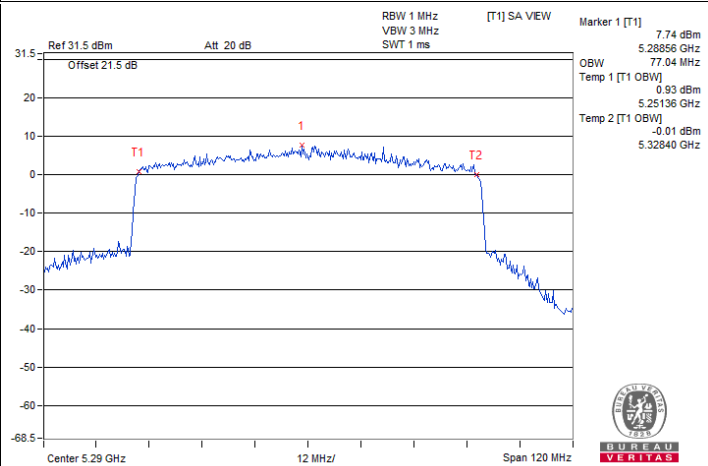

802.11ax (HE80) / Chain1 : CH 58

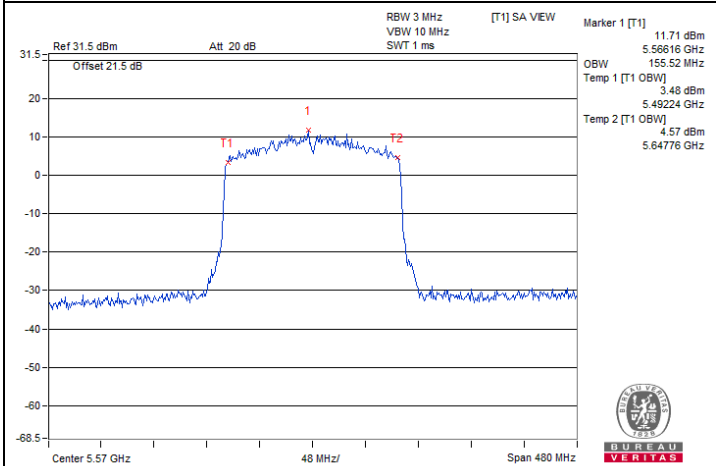

802.11ax (HE160) / Chain0 : CH 114

7.5 Frequency Stability

Input Power:	120 Vac, 60 Hz	Environmental Conditions:	25°C, 60% RH	Tested By:	Waydi Tuan
--------------	----------------	---------------------------	--------------	------------	------------

802.11a

Frequency Stability Versus Temp.									
Operating Frequency: 5260 MHz									
TEMP. (°C)	Power Supply (Vac)	0 Minute		2 Minutes		5 Minutes		10 Minutes	
		Measured Frequency (MHz)	Test Result	Measured Frequency (MHz)	Test Result	Measured Frequency (MHz)	Test Result	Measured Frequency (MHz)	Test Result
40	120	5260.0265	Pass	5260.0254	Pass	5260.0222	Pass	5260.0265	Pass
30	120	5260.0126	Pass	5260.0084	Pass	5260.0119	Pass	5260.0105	Pass
20	120	5259.9877	Pass	5259.9905	Pass	5259.9875	Pass	5259.9887	Pass
10	120	5259.9991	Pass	5260.0009	Pass	5259.9995	Pass	5259.9985	Pass
0	120	5260.0009	Pass	5260.0006	Pass	5260	Pass	5260.0019	Pass

Frequency Stability Versus Voltage									
Operating Frequency: 5260 MHz									
TEMP. (°C)	Power Supply (Vac)	0 Minute		2 Minutes		5 Minutes		10 Minutes	
		Measured Frequency (MHz)	Test Result	Measured Frequency (MHz)	Test Result	Measured Frequency (MHz)	Test Result	Measured Frequency (MHz)	Test Result
20	138	5259.9884	Pass	5259.9853	Pass	5259.9878	Pass	5259.9884	Pass
	120	5259.9877	Pass	5259.9905	Pass	5259.9875	Pass	5259.9887	Pass
	102	5259.9916	Pass	5259.992	Pass	5259.9935	Pass	5259.9942	Pass

7.6 AC Power Conducted Emissions

RF Mode	TX 802.11ax (HE20)	Channel	CH 64 : 5320 MHz
Frequency Range	150 kHz ~ 30 MHz	Detector Function & Resolution Bandwidth	Quasi-Peak (QP) / Average (AV), 9 kHz
Input Power	120 Vac, 60 Hz	Environmental Conditions	25°C, 75% RH
Tested By	Ryan Du		

Phase Of Power : Line (L)										
No	Frequency (MHz)	Correction Factor (dB)	Reading Value (dBuV)		Emission Level (dBuV)		Limit (dBuV)		Margin (dB)	
			Q.P.	AV.	Q.P.	AV.	Q.P.	AV.	Q.P.	AV.
1	0.15012	10.07	45.62	31.72	55.69	41.79	65.99	55.99	-10.30	-14.20
2	0.16178	10.07	39.90	24.83	49.97	34.90	65.37	55.37	-15.40	-20.47
3	0.18901	10.08	37.50	25.91	47.58	35.99	64.08	54.08	-16.50	-18.09
4	0.22429	10.08	32.94	23.84	43.02	33.92	62.66	52.66	-19.64	-18.74
5	0.36482	10.10	33.64	28.58	43.74	38.68	58.62	48.62	-14.88	-9.94
6	9.03524	10.71	19.74	11.91	30.45	22.62	60.00	50.00	-29.55	-27.38

Remarks:

1. Q.P. and AV. are abbreviations of quasi-peak and average individually.
2. The emission levels of other frequencies were very low against the limit.
3. Margin value = Emission level – Limit value
4. Correction factor = Insertion loss + Cable loss
5. Emission Level = Correction Factor + Reading Value

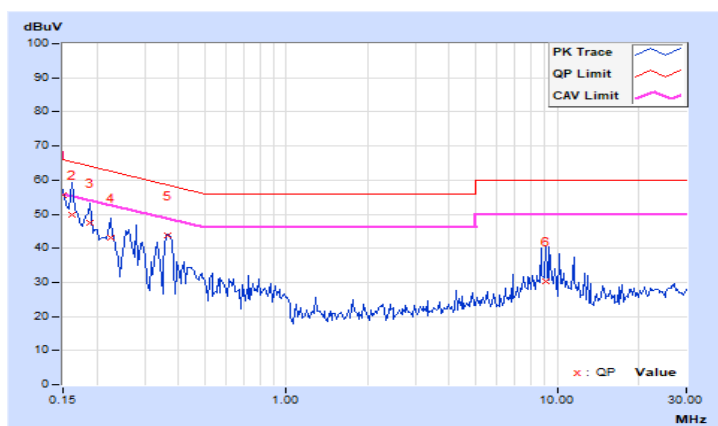

RF Mode	TX 802.11ax (HE20)	Channel	CH 64 : 5320 MHz
Frequency Range	150 kHz ~ 30 MHz	Detector Function & Resolution Bandwidth	Quasi-Peak (QP) / Average (AV), 9 kHz
Input Power	120 Vac, 60 Hz	Environmental Conditions	25°C, 75% RH
Tested By	Ryan Du		

Phase Of Power : Neutral (N)										
No	Frequency (MHz)	Correction Factor (dB)	Reading Value (dBuV)		Emission Level (dBuV)		Limit (dBuV)		Margin (dB)	
			Q.P.	AV.	Q.P.	AV.	Q.P.	AV.	Q.P.	AV.
1	0.15000	10.05	43.73	28.92	53.78	38.97	66.00	56.00	-12.22	-17.03
2	0.16569	10.06	37.52	19.83	47.58	29.89	65.17	55.17	-17.59	-25.28
3	0.18523	10.07	36.56	22.17	46.63	32.24	64.25	54.25	-17.62	-22.01
4	0.20084	10.08	31.42	15.53	41.50	25.61	63.58	53.58	-22.08	-27.97
5	0.25553	10.09	28.83	18.16	38.92	28.25	61.58	51.58	-22.66	-23.33
6	9.11724	10.63	22.11	14.31	32.74	24.94	60.00	50.00	-27.26	-25.06

Remarks:

1. Q.P. and AV. are abbreviations of quasi-peak and average individually.
2. The emission levels of other frequencies were very low against the limit.
3. Margin value = Emission level – Limit value
4. Correction factor = Insertion loss + Cable loss
5. Emission Level = Correction Factor + Reading Value

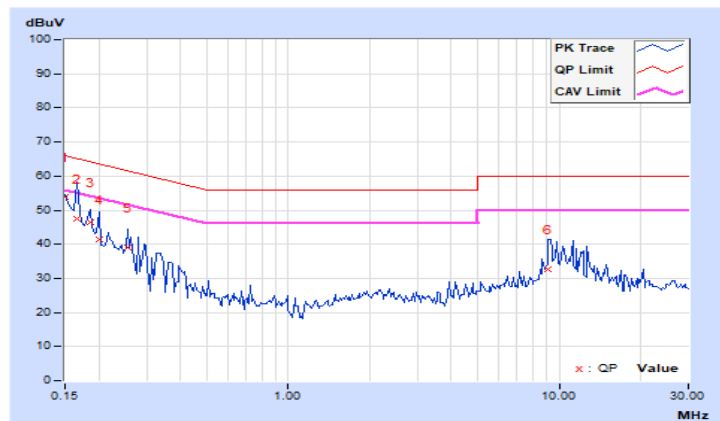

7.7 Unwanted Emissions below 1 GHz

RF Mode	TX 802.11ax (HE20)	Channel	CH 64 : 5320 MHz
Frequency Range	9 kHz ~ 1 GHz	Detector Function & Bandwidth	(QP) RB = 120kHz
Input Power	120 Vac, 60 Hz	Environmental Conditions	20°C, 70% RH
Tested By	Ryan Du		

Antenna Polarity & Test Distance : Horizontal at 3 m								
No	Frequency (MHz)	Emission Level (dBuV/m)	Limit (dBuV/m)	Margin (dB)	Antenna Height (m)	Table Angle (Degree)	Raw Value (dBuV)	Correction Factor (dB/m)
1	37.32	36.4 QP	40.0	-3.6	2.00 H	226	45.2	-8.8
2	73.03	29.6 QP	40.0	-10.4	1.50 H	352	40.7	-11.1
3	97.78	30.8 QP	43.5	-12.7	1.50 H	294	43.9	-13.1
4	148.04	29.2 QP	43.5	-14.3	1.00 H	57	37.3	-8.1
5	250.02	25.0 QP	46.0	-21.0	2.00 H	35	34.6	-9.6
6	640.03	31.2 QP	46.0	-14.8	1.50 H	86	31.1	0.1

Remarks:

1. Emission Level(dBuV/m) = Raw Value(dBuV) + Correction Factor(dB/m)
2. Correction Factor(dB/m) = Antenna Factor(dB/m) + Cable Factor(dB) – Pre-Amplifier Factor(dB)
3. Margin value = Emission Level – Limit value
4. The other emission levels were very low against the limit of frequency range 30 MHz ~ 1 GHz.
5. The emission levels were very low against the limit of frequency range 9 kHz ~ 30 MHz: the amplitude of spurious emissions attenuated more than 20 dB below the permissible value to be report.

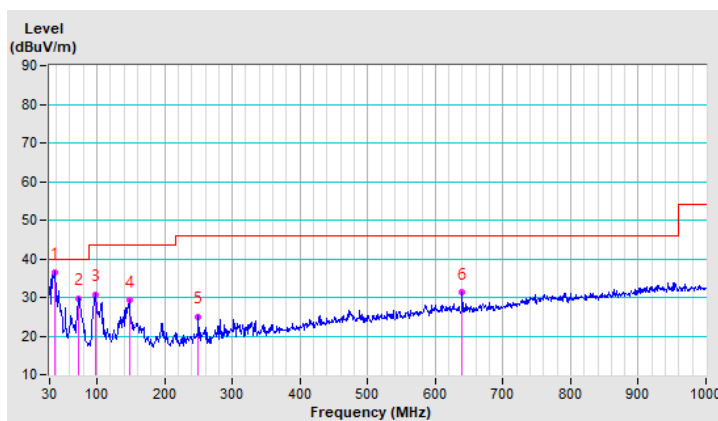

RF Mode	TX 802.11ax (HE20)	Channel	CH 64 : 5320 MHz
Frequency Range	9 kHz ~ 1 GHz	Detector Function & Bandwidth	(QP) RB = 120kHz
Input Power	120 Vac, 60 Hz	Environmental Conditions	20°C, 70% RH
Tested By	Ryan Du		

Antenna Polarity & Test Distance : Vertical at 3 m								
No	Frequency (MHz)	Emission Level (dBuV/m)	Limit (dBuV/m)	Margin (dB)	Antenna Height (m)	Table Angle (Degree)	Raw Value (dBuV)	Correction Factor (dB/m)
1	42.88	36.6 QP	40.0	-3.4	2.00 V	53	44.9	-8.3
2	73.18	32.1 QP	40.0	-7.9	1.00 V	345	43.2	-11.1
3	106.72	32.0 QP	43.5	-11.5	2.00 V	348	43.4	-11.4
4	141.19	26.3 QP	43.5	-17.2	2.00 V	352	34.7	-8.4
5	249.99	22.1 QP	46.0	-23.9	1.50 V	16	31.7	-9.6
6	639.99	30.1 QP	46.0	-15.9	2.00 V	168	30.0	0.1

Remarks:

1. Emission Level(dBuV/m) = Raw Value(dBuV) + Correction Factor(dB/m)
2. Correction Factor(dB/m) = Antenna Factor(dB/m) + Cable Factor(dB) – Pre-Amplifier Factor(dB)
3. Margin value = Emission Level – Limit value
4. The other emission levels were very low against the limit of frequency range 30 MHz ~ 1 GHz.
5. The emission levels were very low against the limit of frequency range 9 kHz ~ 30 MHz: the amplitude of spurious emissions attenuated more than 20 dB below the permissible value to be report.

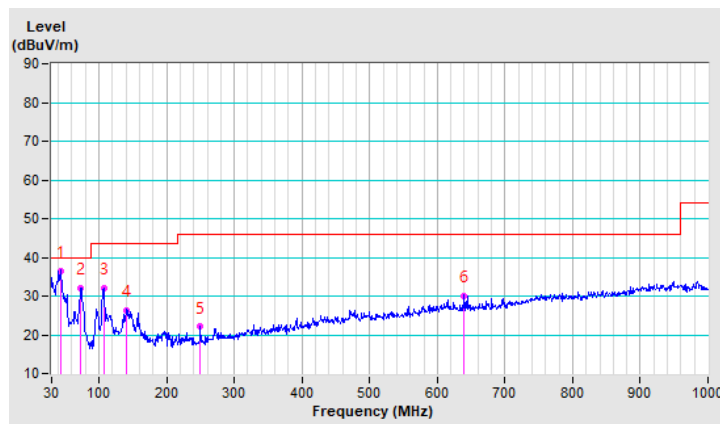

7.8 Unwanted Emissions above 1 GHz

RF Mode	TX 802.11a	Channel	CH 52 : 5260 MHz
Frequency Range	1 GHz ~ 40 GHz	Detector Function & Bandwidth	(PK) RB = 1 MHz, VB = 3 MHz (AV) RB = 1 MHz, VB = 10 Hz
Input Power	120 Vac, 60 Hz	Environmental Conditions	20°C, 70% RH
Tested By	Ryan Du		

Antenna Polarity & Test Distance : Horizontal at 3 m								
No	Frequency (MHz)	Emission Level (dBuV/m)	Limit (dBuV/m)	Margin (dB)	Antenna Height (m)	Table Angle (Degree)	Raw Value (dBuV)	Correction Factor (dB/m)
1	*5260.00	119.9 PK			1.65 H	47	115.5	4.4
2	*5260.00	110.3 AV			1.65 H	47	105.9	4.4
3	5421.98	54.3 PK	74.0	-19.7	1.65 H	47	49.6	4.7
4	5421.98	43.5 AV	54.0	-10.5	1.65 H	47	38.8	4.7
5	#10520.00	56.3 PK	68.2	-11.9	1.50 H	297	41.9	14.4
6	15780.00	56.6 PK	74.0	-17.4	1.62 H	34	43.0	13.6
7	15780.00	44.7 AV	54.0	-9.3	1.62 H	34	31.1	13.6

Remarks:

1. Emission Level(dBuV/m) = Raw Value(dBuV) + Correction Factor(dB/m)
2. Correction Factor(dB/m) = Antenna Factor(dB/m) + Cable Factor(dB) – Pre-Amplifier Factor(dB)
3. Margin value = Emission Level – Limit value
4. The other emission levels were very low against the limit.
5. " * " : Fundamental frequency, the limit was restricted at the RF Output Power.
6. " # " : The radiated frequency is out of the restricted band.

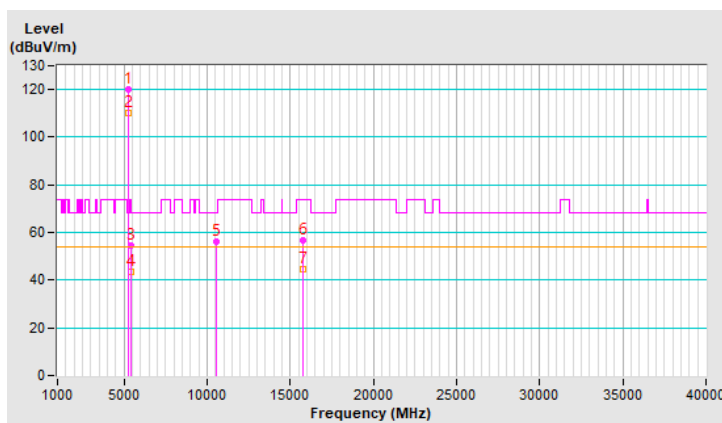

RF Mode	TX 802.11a	Channel	CH 52 : 5260 MHz
Frequency Range	1 GHz ~ 40 GHz	Detector Function & Bandwidth	(PK) RB = 1 MHz, VB = 3 MHz (AV) RB = 1 MHz, VB = 10 Hz
Input Power	120 Vac, 60 Hz	Environmental Conditions	20°C, 70% RH
Tested By	Ryan Du		

Antenna Polarity & Test Distance : Vertical at 3 m								
No	Frequency (MHz)	Emission Level (dBuV/m)	Limit (dBuV/m)	Margin (dB)	Antenna Height (m)	Table Angle (Degree)	Raw Value (dBuV)	Correction Factor (dB/m)
1	5101.18	54.2 PK	74.0	-19.8	1.84 V	293	49.4	4.8
2	5101.18	44.0 AV	54.0	-10.0	1.84 V	293	39.2	4.8
3	*5260.00	124.1 PK			1.84 V	293	119.7	4.4
4	*5260.00	115.7 AV			1.84 V	293	111.3	4.4
5	5418.77	53.7 PK	74.0	-20.3	1.84 V	293	49.0	4.7
6	5418.77	43.6 AV	54.0	-10.4	1.84 V	293	38.9	4.7
7	#10520.00	61.5 PK	68.2	-6.7	1.86 V	311	47.1	14.4
8	15780.00	56.6 PK	74.0	-17.4	1.46 V	100	43.0	13.6
9	15780.00	46.0 AV	54.0	-8.0	1.46 V	100	32.4	13.6

Remarks:

1. Emission Level(dBuV/m) = Raw Value(dBuV) + Correction Factor(dB/m)
2. Correction Factor(dB/m) = Antenna Factor(dB/m) + Cable Factor(dB) – Pre-Amplifier Factor(dB)
3. Margin value = Emission Level – Limit value
4. The other emission levels were very low against the limit.
5. " * " : Fundamental frequency, the limit was restricted at the RF Output Power.
6. " # " : The radiated frequency is out of the restricted band.

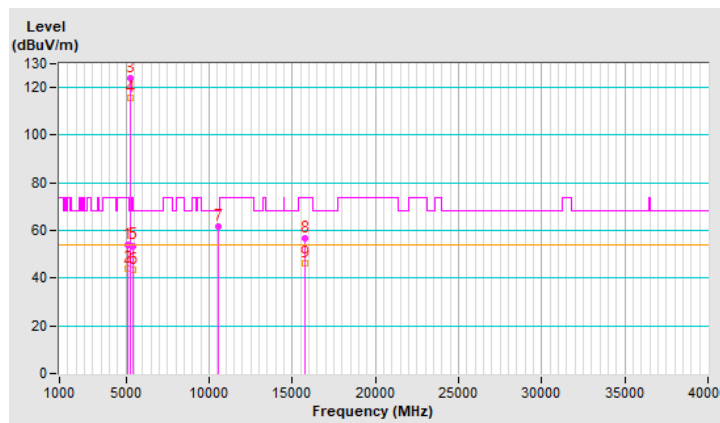

RF Mode	TX 802.11a	Channel	CH 60 : 5300 MHz
Frequency Range	1 GHz ~ 40 GHz	Detector Function & Bandwidth	(PK) RB = 1 MHz, VB = 3 MHz (AV) RB = 1 MHz, VB = 10 Hz
Input Power	120 Vac, 60 Hz	Environmental Conditions	20°C, 70% RH
Tested By	Ryan Du		

Antenna Polarity & Test Distance : Horizontal at 3 m

No	Frequency (MHz)	Emission Level (dBuV/m)	Limit (dBuV/m)	Margin (dB)	Antenna Height (m)	Table Angle (Degree)	Raw Value (dBuV)	Correction Factor (dB/m)
1	*5300.00	122.1 PK			1.63 H	61	117.8	4.3
2	*5300.00	111.4 AV			1.63 H	61	107.1	4.3
3	10600.00	55.9 PK	74.0	-18.1	1.49 H	271	41.7	14.2
4	10600.00	44.7 AV	54.0	-9.3	1.49 H	271	30.5	14.2
5	15900.00	57.0 PK	74.0	-17.0	1.57 H	61	43.2	13.8
6	15900.00	44.9 AV	54.0	-9.1	1.57 H	61	31.1	13.8

Remarks:

1. Emission Level(dBuV/m) = Raw Value(dBuV) + Correction Factor(dB/m)
2. Correction Factor(dB/m) = Antenna Factor(dB/m) + Cable Factor(dB) – Pre-Amplifier Factor(dB)
3. Margin value = Emission Level – Limit value
4. The other emission levels were very low against the limit.
5. " * " : Fundamental frequency, the limit was restricted at the RF Output Power.

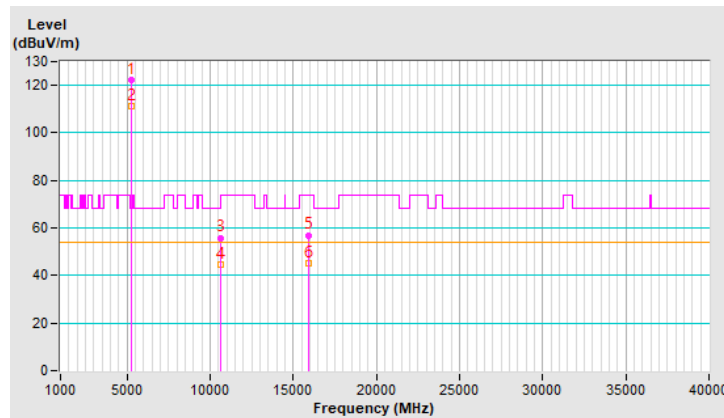

RF Mode	TX 802.11a	Channel	CH 60 : 5300 MHz
Frequency Range	1 GHz ~ 40 GHz	Detector Function & Bandwidth	(PK) RB = 1 MHz, VB = 3 MHz (AV) RB = 1 MHz, VB = 10 Hz
Input Power	120 Vac, 60 Hz	Environmental Conditions	20°C, 70% RH
Tested By	Ryan Du		

Antenna Polarity & Test Distance : Vertical at 3 m

No	Frequency (MHz)	Emission Level (dBuV/m)	Limit (dBuV/m)	Margin (dB)	Antenna Height (m)	Table Angle (Degree)	Raw Value (dBuV)	Correction Factor (dB/m)
1	*5300.00	124.1 PK			1.80 V	298	119.8	4.3
2	*5300.00	115.6 AV			1.80 V	298	111.3	4.3
3	10600.00	59.2 PK	74.0	-14.8	1.93 V	324	45.0	14.2
4	10600.00	48.3 AV	54.0	-5.7	1.93 V	324	34.1	14.2
5	15900.00	56.1 PK	74.0	-17.9	1.38 V	84	42.3	13.8
6	15900.00	45.7 AV	54.0	-8.3	1.38 V	84	31.9	13.8

Remarks:

1. Emission Level(dBuV/m) = Raw Value(dBuV) + Correction Factor(dB/m)
2. Correction Factor(dB/m) = Antenna Factor(dB/m) + Cable Factor(dB) – Pre-Amplifier Factor(dB)
3. Margin value = Emission Level – Limit value
4. The other emission levels were very low against the limit.
5. " * " : Fundamental frequency, the limit was restricted at the RF Output Power.

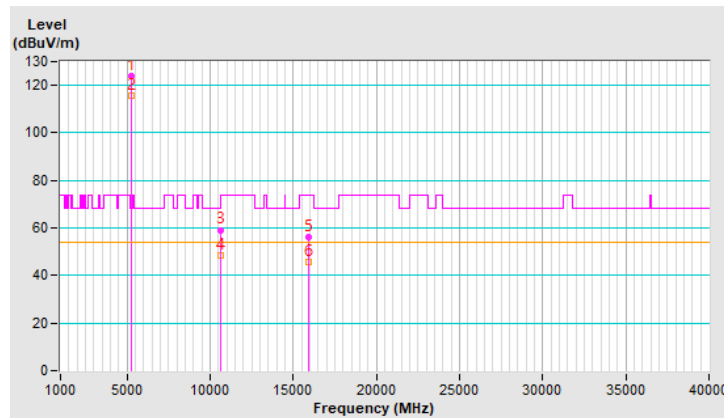

RF Mode	TX 802.11a	Channel	CH 64 : 5320 MHz
Frequency Range	1 GHz ~ 40 GHz	Detector Function & Bandwidth	(PK) RB = 1 MHz, VB = 3 MHz (AV) RB = 1 MHz, VB = 10 Hz
Input Power	120 Vac, 60 Hz	Environmental Conditions	20°C, 70% RH
Tested By	Ryan Du		

Antenna Polarity & Test Distance : Horizontal at 3 m

No	Frequency (MHz)	Emission Level (dBuV/m)	Limit (dBuV/m)	Margin (dB)	Antenna Height (m)	Table Angle (Degree)	Raw Value (dBuV)	Correction Factor (dB/m)
1	*5320.00	120.3 PK			1.49 H	49	115.8	4.5
2	*5320.00	111.9 AV			1.49 H	49	107.4	4.5
3	5350.00	60.8 PK	74.0	-13.2	1.49 H	49	56.2	4.6
4	5350.00	49.5 AV	54.0	-4.5	1.49 H	49	44.9	4.6
5	10640.00	56.1 PK	74.0	-17.9	1.55 H	283	41.8	14.3
6	10640.00	45.1 AV	54.0	-8.9	1.55 H	283	30.8	14.3
7	15960.00	56.7 PK	74.0	-17.3	1.62 H	48	42.8	13.9
8	15960.00	44.8 AV	54.0	-9.2	1.62 H	48	30.9	13.9

Remarks:

1. Emission Level(dBuV/m) = Raw Value(dBuV) + Correction Factor(dB/m)
2. Correction Factor(dB/m) = Antenna Factor(dB/m) + Cable Factor(dB) – Pre-Amplifier Factor(dB)
3. Margin value = Emission Level – Limit value
4. The other emission levels were very low against the limit.
5. " * ": Fundamental frequency, the limit was restricted at the RF Output Power.

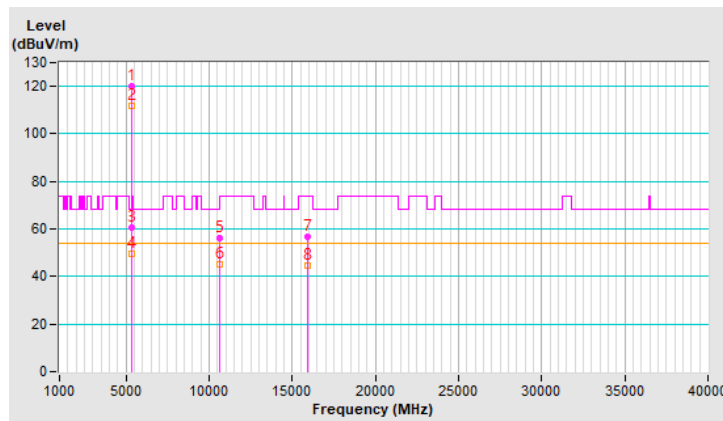

RF Mode	TX 802.11a	Channel	CH 64 : 5320 MHz
Frequency Range	1 GHz ~ 40 GHz	Detector Function & Bandwidth	(PK) RB = 1 MHz, VB = 3 MHz (AV) RB = 1 MHz, VB = 10 Hz
Input Power	120 Vac, 60 Hz	Environmental Conditions	20°C, 70% RH
Tested By	Ryan Du		

Antenna Polarity & Test Distance : Vertical at 3 m								
No	Frequency (MHz)	Emission Level (dBuV/m)	Limit (dBuV/m)	Margin (dB)	Antenna Height (m)	Table Angle (Degree)	Raw Value (dBuV)	Correction Factor (dB/m)
1	*5320.00	124.6 PK			1.70 V	263	120.1	4.5
2	*5320.00	116.0 AV			1.70 V	263	111.5	4.5
3	5350.00	61.8 PK	74.0	-12.2	1.70 V	263	57.2	4.6
4	5350.00	53.2 AV	54.0	-0.8	1.70 V	263	48.6	4.6
5	10640.00	59.3 PK	74.0	-14.7	1.90 V	327	45.0	14.3
6	10640.00	48.4 AV	54.0	-5.6	1.90 V	327	34.1	14.3
7	15960.00	55.5 PK	74.0	-18.5	1.32 V	77	41.6	13.9
8	15960.00	45.4 AV	54.0	-8.6	1.32 V	77	31.5	13.9

Remarks:

1. Emission Level(dBuV/m) = Raw Value(dBuV) + Correction Factor(dB/m)
2. Correction Factor(dB/m) = Antenna Factor(dB/m) + Cable Factor(dB) – Pre-Amplifier Factor(dB)
3. Margin value = Emission Level – Limit value
4. The other emission levels were very low against the limit.
5. " * ": Fundamental frequency, the limit was restricted at the RF Output Power.

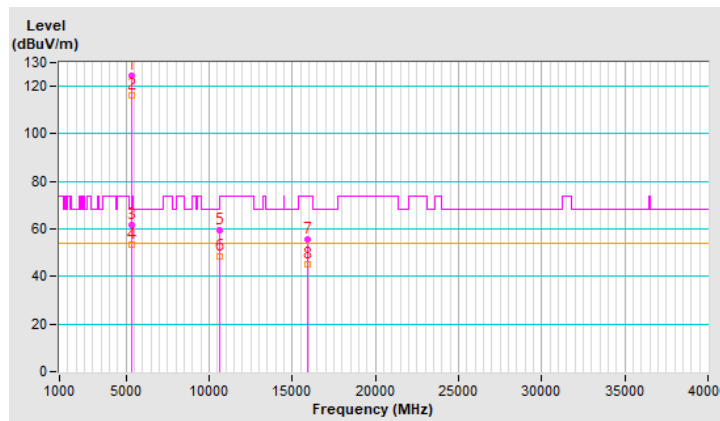

RF Mode	TX 802.11a	Channel	CH 100 : 5500 MHz
Frequency Range	1 GHz ~ 40 GHz	Detector Function & Bandwidth	(PK) RB = 1 MHz, VB = 3 MHz (AV) RB = 1 MHz, VB = 10 Hz
Input Power	120 Vac, 60 Hz	Environmental Conditions	20°C, 70% RH
Tested By	Ryan Du		

Antenna Polarity & Test Distance : Horizontal at 3 m

No	Frequency (MHz)	Emission Level (dBuV/m)	Limit (dBuV/m)	Margin (dB)	Antenna Height (m)	Table Angle (Degree)	Raw Value (dBuV)	Correction Factor (dB/m)
1	5421.51	55.7 PK	74.0	-18.3	1.07 H	70	51.0	4.7
2	5421.51	47.1 AV	54.0	-6.9	1.07 H	70	42.4	4.7
3	#5466.90	62.1 PK	68.2	-6.1	1.07 H	70	57.3	4.8
4	*5500.00	120.2 PK			1.07 H	70	115.4	4.8
5	*5500.00	111.6 AV			1.07 H	70	106.8	4.8
6	11000.00	55.9 PK	74.0	-18.1	1.52 H	274	41.1	14.8
7	11000.00	45.1 AV	54.0	-8.9	1.52 H	274	30.3	14.8
8	#16500.00	56.0 PK	68.2	-12.2	1.63 H	21	40.7	15.3

Remarks:

1. Emission Level(dBuV/m) = Raw Value(dBuV) + Correction Factor(dB/m)
2. Correction Factor(dB/m) = Antenna Factor(dB/m) + Cable Factor(dB) – Pre-Amplifier Factor(dB)
3. Margin value = Emission Level – Limit value
4. The other emission levels were very low against the limit.
5. " * " : Fundamental frequency, the limit was restricted at the RF Output Power.
6. " # " : The radiated frequency is out of the restricted band.

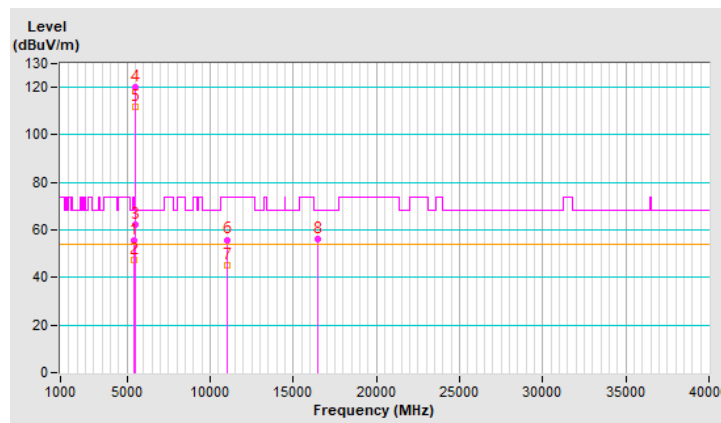

RF Mode	TX 802.11a	Channel	CH 100 : 5500 MHz
Frequency Range	1 GHz ~ 40 GHz	Detector Function & Bandwidth	(PK) RB = 1 MHz, VB = 3 MHz (AV) RB = 1 MHz, VB = 10 Hz
Input Power	120 Vac, 60 Hz	Environmental Conditions	20°C, 70% RH
Tested By	Ryan Du		

Antenna Polarity & Test Distance : Vertical at 3 m

No	Frequency (MHz)	Emission Level (dBuV/m)	Limit (dBuV/m)	Margin (dB)	Antenna Height (m)	Table Angle (Degree)	Raw Value (dBuV)	Correction Factor (dB/m)
1	5460.00	62.3 PK	74.0	-11.7	1.65 V	253	57.5	4.8
2	5460.00	49.9 AV	54.0	-4.1	1.65 V	253	45.1	4.8
3	#5470.00	67.4 PK	68.2	-0.8	1.65 V	253	62.6	4.8
4	*5500.00	125.2 PK			1.65 V	253	120.4	4.8
5	*5500.00	117.5 AV			1.65 V	253	112.7	4.8
6	11000.00	59.3 PK	74.0	-14.7	1.93 V	332	44.5	14.8
7	11000.00	48.5 AV	54.0	-5.5	1.93 V	332	33.7	14.8
8	#16500.00	56.4 PK	68.2	-11.8	1.41 V	70	41.1	15.3

Remarks:

1. Emission Level(dBuV/m) = Raw Value(dBuV) + Correction Factor(dB/m)
2. Correction Factor(dB/m) = Antenna Factor(dB/m) + Cable Factor(dB) – Pre-Amplifier Factor(dB)
3. Margin value = Emission Level – Limit value
4. The other emission levels were very low against the limit.
5. " * ": Fundamental frequency, the limit was restricted at the RF Output Power.
6. " # ": The radiated frequency is out of the restricted band.

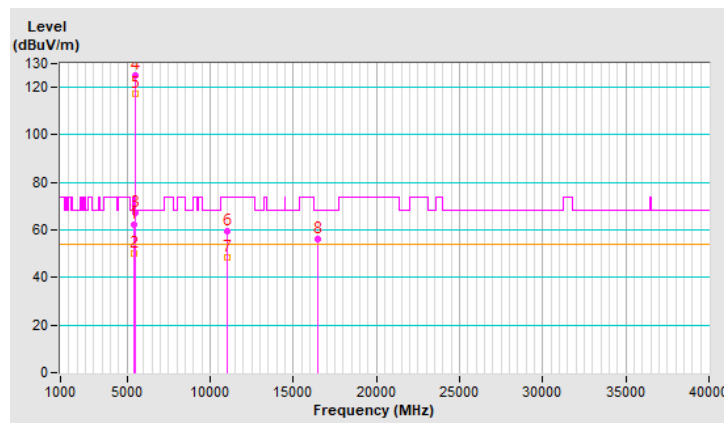

RF Mode	TX 802.11a	Channel	CH 116 : 5580 MHz
Frequency Range	1 GHz ~ 40 GHz	Detector Function & Bandwidth	(PK) RB = 1 MHz, VB = 3 MHz (AV) RB = 1 MHz, VB = 10 Hz
Input Power	120 Vac, 60 Hz	Environmental Conditions	20°C, 70% RH
Tested By	Ryan Du		

Antenna Polarity & Test Distance : Horizontal at 3 m

No	Frequency (MHz)	Emission Level (dBuV/m)	Limit (dBuV/m)	Margin (dB)	Antenna Height (m)	Table Angle (Degree)	Raw Value (dBuV)	Correction Factor (dB/m)
1	*5580.00	119.9 PK			1.64 H	46	115.1	4.8
2	*5580.00	111.2 AV			1.64 H	46	106.4	4.8
3	11160.00	55.8 PK	74.0	-18.2	1.53 H	285	41.2	14.6
4	11160.00	44.8 AV	54.0	-9.2	1.53 H	285	30.2	14.6
5	#16740.00	56.3 PK	68.2	-11.9	1.61 H	32	39.5	16.8

Remarks:

1. Emission Level(dBuV/m) = Raw Value(dBuV) + Correction Factor(dB/m)
2. Correction Factor(dB/m) = Antenna Factor(dB/m) + Cable Factor(dB) – Pre-Amplifier Factor(dB)
3. Margin value = Emission Level – Limit value
4. The other emission levels were very low against the limit.
5. " * " : Fundamental frequency, the limit was restricted at the RF Output Power.
6. " # " : The radiated frequency is out of the restricted band.

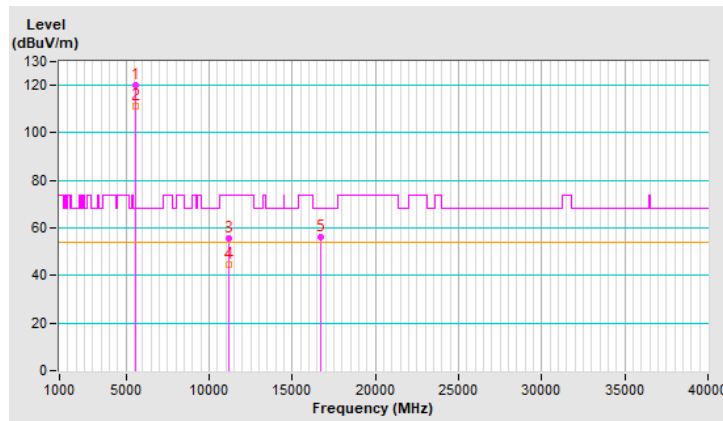

RF Mode	TX 802.11a	Channel	CH 116 : 5580 MHz
Frequency Range	1 GHz ~ 40 GHz	Detector Function & Bandwidth	(PK) RB = 1 MHz, VB = 3 MHz (AV) RB = 1 MHz, VB = 10 Hz
Input Power	120 Vac, 60 Hz	Environmental Conditions	20°C, 70% RH
Tested By	Ryan Du		

Antenna Polarity & Test Distance : Vertical at 3 m								
No	Frequency (MHz)	Emission Level (dBuV/m)	Limit (dBuV/m)	Margin (dB)	Antenna Height (m)	Table Angle (Degree)	Raw Value (dBuV)	Correction Factor (dB/m)
1	*5580.00	124.6 PK			1.80 V	275	119.8	4.8
2	*5580.00	117.1 AV			1.80 V	275	112.3	4.8
3	11160.00	59.2 PK	74.0	-14.8	1.95 V	325	44.6	14.6
4	11160.00	48.3 AV	54.0	-5.7	1.95 V	325	33.7	14.6
5	#16740.00	56.6 PK	68.2	-11.6	1.36 V	92	39.8	16.8

Remarks:

1. Emission Level(dBuV/m) = Raw Value(dBuV) + Correction Factor(dB/m)
2. Correction Factor(dB/m) = Antenna Factor(dB/m) + Cable Factor(dB) – Pre-Amplifier Factor(dB)
3. Margin value = Emission Level – Limit value
4. The other emission levels were very low against the limit.
5. " * " : Fundamental frequency, the limit was restricted at the RF Output Power.
6. " # " : The radiated frequency is out of the restricted band.

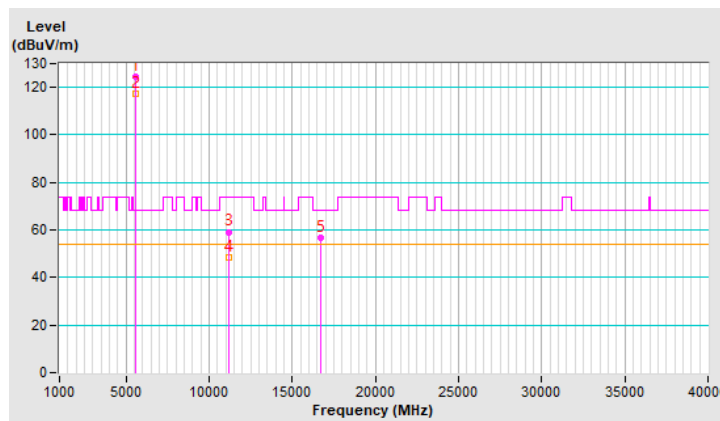

RF Mode	TX 802.11a	Channel	CH 140 : 5700 MHz
Frequency Range	1 GHz ~ 40 GHz	Detector Function & Bandwidth	(PK) RB = 1 MHz, VB = 3 MHz (AV) RB = 1 MHz, VB = 10 Hz
Input Power	120 Vac, 60 Hz	Environmental Conditions	20°C, 70% RH
Tested By	Ryan Du		

Antenna Polarity & Test Distance : Horizontal at 3 m

No	Frequency (MHz)	Emission Level (dBuV/m)	Limit (dBuV/m)	Margin (dB)	Antenna Height (m)	Table Angle (Degree)	Raw Value (dBuV)	Correction Factor (dB/m)
1	*5700.00	120.2 PK			1.71 H	67	115.5	4.7
2	*5700.00	111.7 AV			1.71 H	67	107.0	4.7
3	#5725.00	62.1 PK	68.2	-6.1	1.71 H	67	57.2	4.9
4	11400.00	55.9 PK	74.0	-18.1	1.52 H	300	40.5	15.4
5	11400.00	45.0 AV	54.0	-9.0	1.52 H	300	29.6	15.4
6	#17100.00	56.9 PK	68.2	-11.3	1.57 H	36	38.4	18.5

Remarks:

1. Emission Level(dBuV/m) = Raw Value(dBuV) + Correction Factor(dB/m)
2. Correction Factor(dB/m) = Antenna Factor(dB/m) + Cable Factor(dB) – Pre-Amplifier Factor(dB)
3. Margin value = Emission Level – Limit value
4. The other emission levels were very low against the limit.
5. " * " : Fundamental frequency, the limit was restricted at the RF Output Power.
6. " # " : The radiated frequency is out of the restricted band.

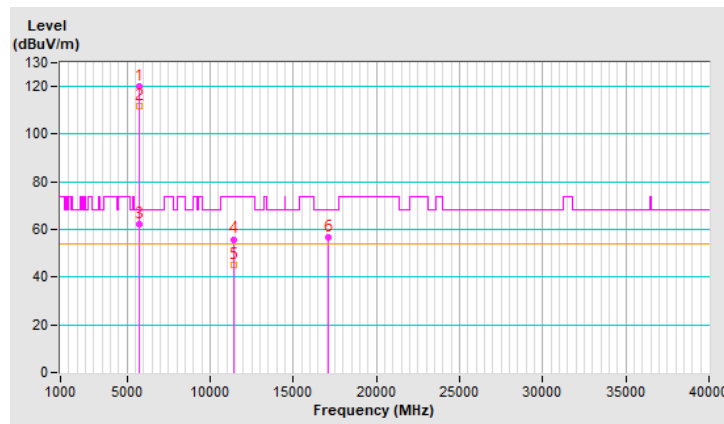

RF Mode	TX 802.11a	Channel	CH 140 : 5700 MHz
Frequency Range	1 GHz ~ 40 GHz	Detector Function & Bandwidth	(PK) RB = 1 MHz, VB = 3 MHz (AV) RB = 1 MHz, VB = 10 Hz
Input Power	120 Vac, 60 Hz	Environmental Conditions	20°C, 70% RH
Tested By	Ryan Du		

Antenna Polarity & Test Distance : Vertical at 3 m								
No	Frequency (MHz)	Emission Level (dBuV/m)	Limit (dBuV/m)	Margin (dB)	Antenna Height (m)	Table Angle (Degree)	Raw Value (dBuV)	Correction Factor (dB/m)
1	*5700.00	122.7 PK			1.37 V	271	118.0	4.7
2	*5700.00	115.3 AV			1.37 V	271	110.6	4.7
3	#5725.00	67.6 PK	68.2	-0.6	1.37 V	271	62.7	4.9
4	11400.00	59.0 PK	74.0	-15.0	1.98 V	315	43.6	15.4
5	11400.00	47.9 AV	54.0	-6.1	1.98 V	315	32.5	15.4
6	#17100.00	55.8 PK	68.2	-12.4	1.42 V	80	37.3	18.5

Remarks:

1. Emission Level(dBuV/m) = Raw Value(dBuV) + Correction Factor(dB/m)
2. Correction Factor(dB/m) = Antenna Factor(dB/m) + Cable Factor(dB) – Pre-Amplifier Factor(dB)
3. Margin value = Emission Level – Limit value
4. The other emission levels were very low against the limit.
5. " * " : Fundamental frequency, the limit was restricted at the RF Output Power.
6. " # " : The radiated frequency is out of the restricted band.

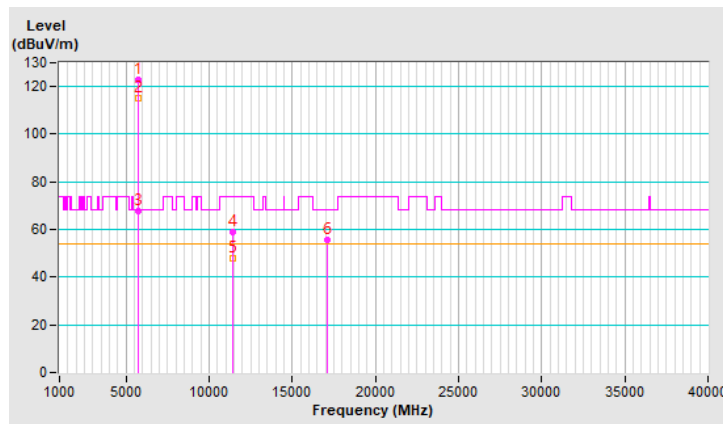

RF Mode	TX 802.11a	Channel	CH 144 : 5720 MHz
Frequency Range	1 GHz ~ 40 GHz	Detector Function & Bandwidth	(PK) RB = 1 MHz, VB = 3 MHz (AV) RB = 1 MHz, VB = 10 Hz
Input Power	120 Vac, 60 Hz	Environmental Conditions	20°C, 70% RH
Tested By	Ryan Du		

Antenna Polarity & Test Distance : Horizontal at 3 m

No	Frequency (MHz)	Emission Level (dBuV/m)	Limit (dBuV/m)	Margin (dB)	Antenna Height (m)	Table Angle (Degree)	Raw Value (dBuV)	Correction Factor (dB/m)
1	*5720.00	119.7 PK			1.72 H	46	114.9	4.8
2	*5720.00	111.2 AV			1.72 H	46	106.4	4.8
3	11440.00	55.6 PK	74.0	-18.4	1.52 H	286	40.3	15.3
4	11440.00	44.7 AV	54.0	-9.3	1.52 H	286	29.4	15.3
5	#17160.00	56.1 PK	68.2	-12.1	1.58 H	36	37.8	18.3

Remarks:

1. Emission Level(dBuV/m) = Raw Value(dBuV) + Correction Factor(dB/m)
2. Correction Factor(dB/m) = Antenna Factor(dB/m) + Cable Factor(dB) – Pre-Amplifier Factor(dB)
3. Margin value = Emission Level – Limit value
4. The other emission levels were very low against the limit.
5. " * " : Fundamental frequency, the limit was restricted at the RF Output Power.
6. " # " : The radiated frequency is out of the restricted band.

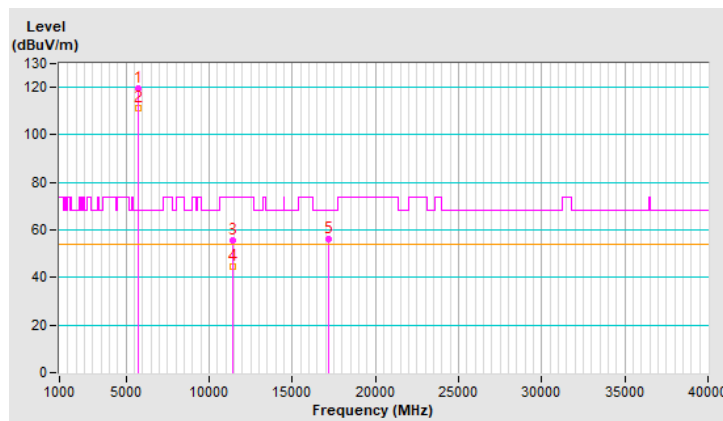

RF Mode	TX 802.11a	Channel	CH 144 : 5720 MHz
Frequency Range	1 GHz ~ 40 GHz	Detector Function & Bandwidth	(PK) RB = 1 MHz, VB = 3 MHz (AV) RB = 1 MHz, VB = 10 Hz
Input Power	120 Vac, 60 Hz	Environmental Conditions	20°C, 70% RH
Tested By	Ryan Du		

Antenna Polarity & Test Distance : Vertical at 3 m								
No	Frequency (MHz)	Emission Level (dBuV/m)	Limit (dBuV/m)	Margin (dB)	Antenna Height (m)	Table Angle (Degree)	Raw Value (dBuV)	Correction Factor (dB/m)
1	*5720.00	123.0 PK			1.88 V	275	118.2	4.8
2	*5720.00	115.4 AV			1.88 V	275	110.6	4.8
3	11440.00	59.9 PK	74.0	-14.1	1.94 V	329	44.6	15.3
4	11440.00	48.8 AV	54.0	-5.2	1.94 V	329	33.5	15.3
5	#17160.00	56.2 PK	68.2	-12.0	1.42 V	88	37.9	18.3

Remarks:

1. Emission Level(dBuV/m) = Raw Value(dBuV) + Correction Factor(dB/m)
2. Correction Factor(dB/m) = Antenna Factor(dB/m) + Cable Factor(dB) – Pre-Amplifier Factor(dB)
3. Margin value = Emission Level – Limit value
4. The other emission levels were very low against the limit.
5. " * " : Fundamental frequency, the limit was restricted at the RF Output Power.
6. " # " : The radiated frequency is out of the restricted band.

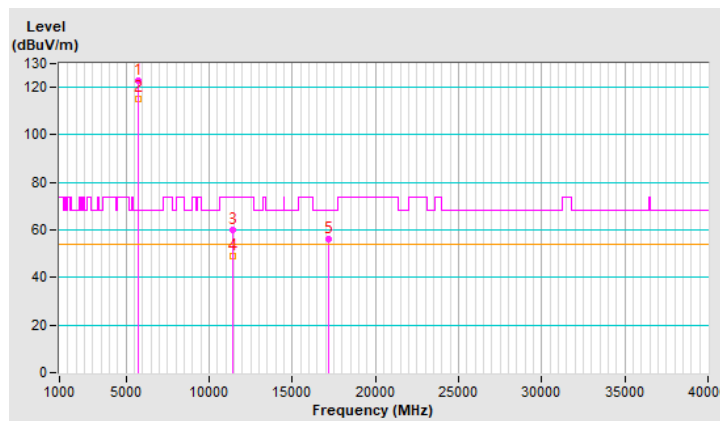

RF Mode	TX 802.11ax (HE20)	Channel	CH 52 : 5260 MHz
Frequency Range	1 GHz ~ 40 GHz	Detector Function & Bandwidth	(PK) RB = 1 MHz, VB = 3 MHz (AV) RB = 1 MHz, VB = 10 Hz
Input Power	120 Vac, 60 Hz	Environmental Conditions	20°C, 70% RH
Tested By	Ryan Du		

Antenna Polarity & Test Distance : Horizontal at 3 m

No	Frequency (MHz)	Emission Level (dBuV/m)	Limit (dBuV/m)	Margin (dB)	Antenna Height (m)	Table Angle (Degree)	Raw Value (dBuV)	Correction Factor (dB/m)
1	*5260.00	121.1 PK			1.66 H	88	116.7	4.4
2	*5260.00	110.2 AV			1.66 H	88	105.8	4.4
3	5424.00	54.2 PK	74.0	-19.8	1.66 H	88	49.5	4.7
4	5424.00	42.8 AV	54.0	-11.2	1.66 H	88	38.1	4.7
5	#10520.00	55.9 PK	68.2	-12.3	1.51 H	281	41.5	14.4
6	15780.00	56.3 PK	74.0	-17.7	1.61 H	28	42.7	13.6
7	15780.00	44.6 AV	54.0	-9.4	1.61 H	28	31.0	13.6

Remarks:

1. Emission Level(dBuV/m) = Raw Value(dBuV) + Correction Factor(dB/m)
2. Correction Factor(dB/m) = Antenna Factor(dB/m) + Cable Factor(dB) – Pre-Amplifier Factor(dB)
3. Margin value = Emission Level – Limit value
4. The other emission levels were very low against the limit.
5. " * " : Fundamental frequency, the limit was restricted at the RF Output Power.
6. " # " : The radiated frequency is out of the restricted band.

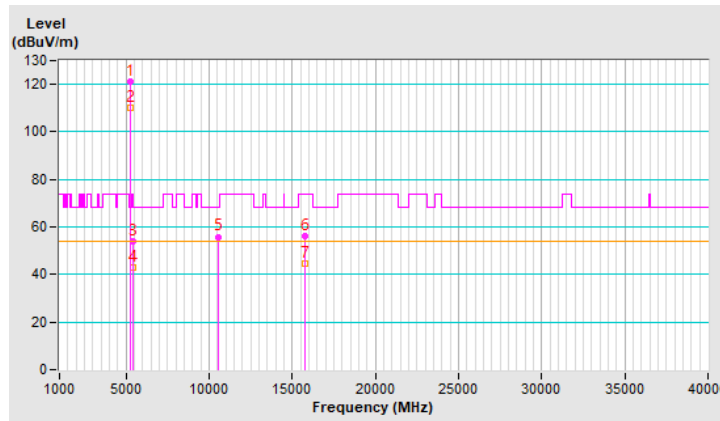

RF Mode	TX 802.11ax (HE20)	Channel	CH 52 : 5260 MHz
Frequency Range	1 GHz ~ 40 GHz	Detector Function & Bandwidth	(PK) RB = 1 MHz, VB = 3 MHz (AV) RB = 1 MHz, VB = 10 Hz
Input Power	120 Vac, 60 Hz	Environmental Conditions	20°C, 70% RH
Tested By	Ryan Du		

Antenna Polarity & Test Distance : Vertical at 3 m

No	Frequency (MHz)	Emission Level (dBuV/m)	Limit (dBuV/m)	Margin (dB)	Antenna Height (m)	Table Angle (Degree)	Raw Value (dBuV)	Correction Factor (dB/m)
1	5102.74	52.8 PK	74.0	-21.2	1.82 V	258	48.0	4.8
2	5102.74	43.4 AV	54.0	-10.6	1.82 V	258	38.6	4.8
3	*5260.00	123.3 PK			1.82 V	258	118.9	4.4
4	*5260.00	114.4 AV			1.82 V	258	110.0	4.4
5	5422.39	53.9 PK	74.0	-20.1	1.82 V	258	49.2	4.7
6	5422.39	44.2 AV	54.0	-9.8	1.82 V	258	39.5	4.7
7	#10520.00	55.2 PK	68.2	-13.0	1.98 V	320	40.8	14.4
8	15780.00	56.4 PK	74.0	-17.6	1.31 V	99	42.8	13.6
9	15780.00	45.8 AV	54.0	-8.2	1.31 V	99	32.2	13.6

Remarks:

1. Emission Level(dBuV/m) = Raw Value(dBuV) + Correction Factor(dB/m)
2. Correction Factor(dB/m) = Antenna Factor(dB/m) + Cable Factor(dB) – Pre-Amplifier Factor(dB)
3. Margin value = Emission Level – Limit value
4. The other emission levels were very low against the limit.
5. " * " : Fundamental frequency, the limit was restricted at the RF Output Power.
6. " # " : The radiated frequency is out of the restricted band.

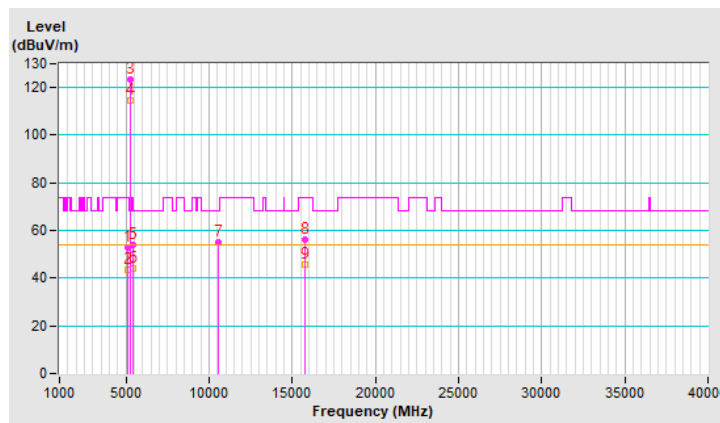

RF Mode	TX 802.11ax (HE20)	Channel	CH 60 : 5300 MHz
Frequency Range	1 GHz ~ 40 GHz	Detector Function & Bandwidth	(PK) RB = 1 MHz, VB = 3 MHz (AV) RB = 1 MHz, VB = 10 Hz
Input Power	120 Vac, 60 Hz	Environmental Conditions	20°C, 70% RH
Tested By	Ryan Du		

Antenna Polarity & Test Distance : Horizontal at 3 m

No	Frequency (MHz)	Emission Level (dBuV/m)	Limit (dBuV/m)	Margin (dB)	Antenna Height (m)	Table Angle (Degree)	Raw Value (dBuV)	Correction Factor (dB/m)
1	*5300.00	120.4 PK			1.68 H	96	116.1	4.3
2	*5300.00	111.3 AV			1.68 H	96	107.0	4.3
3	5350.00	56.3 PK	74.0	-17.7	1.68 H	96	51.7	4.6
4	5350.00	45.2 AV	54.0	-8.8	1.68 H	96	40.6	4.6
5	10600.00	56.2 PK	74.0	-17.8	1.52 H	273	42.0	14.2
6	10600.00	45.1 AV	54.0	-8.9	1.52 H	273	30.9	14.2
7	15900.00	56.2 PK	74.0	-17.8	1.61 H	42	42.4	13.8
8	15900.00	44.3 AV	54.0	-9.7	1.61 H	42	30.5	13.8

Remarks:

1. Emission Level(dBuV/m) = Raw Value(dBuV) + Correction Factor(dB/m)
2. Correction Factor(dB/m) = Antenna Factor(dB/m) + Cable Factor(dB) – Pre-Amplifier Factor(dB)
3. Margin value = Emission Level – Limit value
4. The other emission levels were very low against the limit.
5. " * ": Fundamental frequency, the limit was restricted at the RF Output Power.

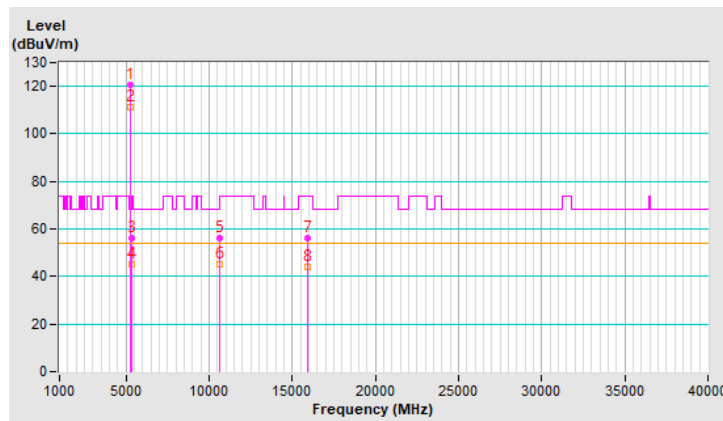

RF Mode	TX 802.11ax (HE20)	Channel	CH 60 : 5300 MHz
Frequency Range	1 GHz ~ 40 GHz	Detector Function & Bandwidth	(PK) RB = 1 MHz, VB = 3 MHz (AV) RB = 1 MHz, VB = 10 Hz
Input Power	120 Vac, 60 Hz	Environmental Conditions	20°C, 70% RH
Tested By	Ryan Du		

Antenna Polarity & Test Distance : Vertical at 3 m								
No	Frequency (MHz)	Emission Level (dBuV/m)	Limit (dBuV/m)	Margin (dB)	Antenna Height (m)	Table Angle (Degree)	Raw Value (dBuV)	Correction Factor (dB/m)
1	*5300.00	123.5 PK			1.75 V	259	119.2	4.3
2	*5300.00	114.2 AV			1.75 V	259	109.9	4.3
3	5350.00	59.1 PK	74.0	-14.9	1.75 V	259	54.5	4.6
4	5350.00	49.1 AV	54.0	-4.9	1.75 V	259	44.5	4.6
5	10600.00	55.3 PK	74.0	-18.7	1.96 V	328	41.1	14.2
6	10600.00	44.6 AV	54.0	-9.4	1.96 V	328	30.4	14.2
7	15900.00	56.2 PK	74.0	-17.8	1.35 V	102	42.4	13.8
8	15900.00	45.9 AV	54.0	-8.1	1.35 V	102	32.1	13.8

Remarks:

1. Emission Level(dBuV/m) = Raw Value(dBuV) + Correction Factor(dB/m)
2. Correction Factor(dB/m) = Antenna Factor(dB/m) + Cable Factor(dB) – Pre-Amplifier Factor(dB)
3. Margin value = Emission Level – Limit value
4. The other emission levels were very low against the limit.
5. " * ": Fundamental frequency, the limit was restricted at the RF Output Power.

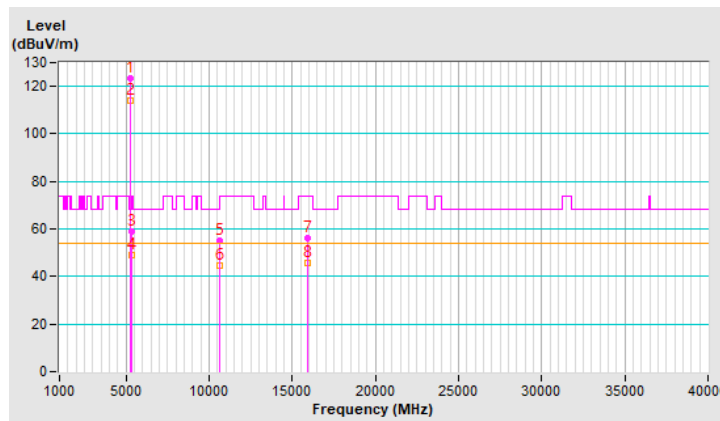

RF Mode	TX 802.11ax (HE20)	Channel	CH 64 : 5320 MHz
Frequency Range	1 GHz ~ 40 GHz	Detector Function & Bandwidth	(PK) RB = 1 MHz, VB = 3 MHz (AV) RB = 1 MHz, VB = 10 Hz
Input Power	120 Vac, 60 Hz	Environmental Conditions	20°C, 70% RH
Tested By	Ryan Du		

Antenna Polarity & Test Distance : Horizontal at 3 m

No	Frequency (MHz)	Emission Level (dBuV/m)	Limit (dBuV/m)	Margin (dB)	Antenna Height (m)	Table Angle (Degree)	Raw Value (dBuV)	Correction Factor (dB/m)
1	*5320.00	120.6 PK			1.31 H	34	116.1	4.5
2	*5320.00	111.6 AV			1.31 H	34	107.1	4.5
3	5350.00	62.2 PK	74.0	-11.8	1.31 H	34	57.6	4.6
4	5350.00	52.1 AV	54.0	-1.9	1.31 H	34	47.5	4.6
5	10640.00	55.9 PK	74.0	-18.1	1.51 H	278	41.6	14.3
6	10640.00	45.2 AV	54.0	-8.8	1.51 H	278	30.9	14.3
7	15960.00	56.0 PK	74.0	-18.0	1.63 H	32	42.1	13.9
8	15960.00	44.2 AV	54.0	-9.8	1.63 H	32	30.3	13.9

Remarks:

1. Emission Level(dBuV/m) = Raw Value(dBuV) + Correction Factor(dB/m)
2. Correction Factor(dB/m) = Antenna Factor(dB/m) + Cable Factor(dB) – Pre-Amplifier Factor(dB)
3. Margin value = Emission Level – Limit value
4. The other emission levels were very low against the limit.
5. " * ": Fundamental frequency, the limit was restricted at the RF Output Power.

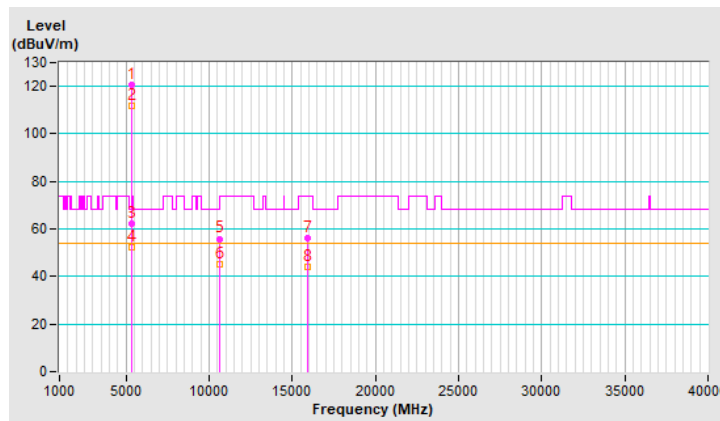

RF Mode	TX 802.11ax (HE20)	Channel	CH 64 : 5320 MHz
Frequency Range	1 GHz ~ 40 GHz	Detector Function & Bandwidth	(PK) RB = 1 MHz, VB = 3 MHz (AV) RB = 1 MHz, VB = 10 Hz
Input Power	120 Vac, 60 Hz	Environmental Conditions	20°C, 70% RH
Tested By	Ryan Du		

Antenna Polarity & Test Distance : Vertical at 3 m

No	Frequency (MHz)	Emission Level (dBuV/m)	Limit (dBuV/m)	Margin (dB)	Antenna Height (m)	Table Angle (Degree)	Raw Value (dBuV)	Correction Factor (dB/m)
1	*5320.00	125.1 PK			1.80 V	256	120.6	4.5
2	*5320.00	115.9 AV			1.80 V	256	111.4	4.5
3	5350.00	63.7 PK	74.0	-10.3	1.80 V	256	59.1	4.6
4	5350.00	53.3 AV	54.0	-0.7	1.80 V	256	48.7	4.6
5	10640.00	54.8 PK	74.0	-19.2	1.92 V	325	40.5	14.3
6	10640.00	44.0 AV	54.0	-10.0	1.92 V	325	29.7	14.3
7	15960.00	56.2 PK	74.0	-17.8	1.34 V	75	42.3	13.9
8	15960.00	46.0 AV	54.0	-8.0	1.34 V	75	32.1	13.9

Remarks:

1. Emission Level(dBuV/m) = Raw Value(dBuV) + Correction Factor(dB/m)
2. Correction Factor(dB/m) = Antenna Factor(dB/m) + Cable Factor(dB) – Pre-Amplifier Factor(dB)
3. Margin value = Emission Level – Limit value
4. The other emission levels were very low against the limit.
5. " * ": Fundamental frequency, the limit was restricted at the RF Output Power.

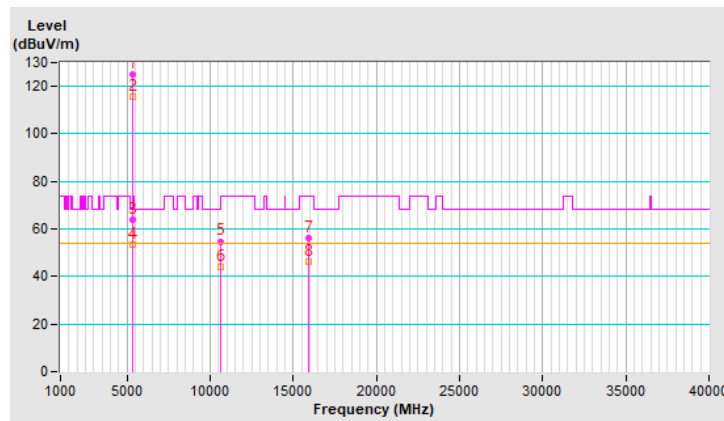

RF Mode	TX 802.11ax (HE20)	Channel	CH 100 : 5500 MHz
Frequency Range	1 GHz ~ 40 GHz	Detector Function & Bandwidth	(PK) RB = 1 MHz, VB = 3 MHz (AV) RB = 1 MHz, VB = 10 Hz
Input Power	120 Vac, 60 Hz	Environmental Conditions	20°C, 70% RH
Tested By	Ryan Du		

Antenna Polarity & Test Distance : Horizontal at 3 m

No	Frequency (MHz)	Emission Level (dBuV/m)	Limit (dBuV/m)	Margin (dB)	Antenna Height (m)	Table Angle (Degree)	Raw Value (dBuV)	Correction Factor (dB/m)
1	5460.00	56.2 PK	74.0	-17.8	2.15 H	74	51.4	4.8
2	5460.00	48.4 AV	54.0	-5.6	2.15 H	74	43.6	4.8
3	#5466.76	65.1 PK	68.2	-3.1	2.15 H	74	60.3	4.8
4	*5500.00	120.9 PK			2.15 H	74	116.1	4.8
5	*5500.00	111.8 AV			2.15 H	74	107.0	4.8
6	11000.00	55.3 PK	74.0	-18.7	1.54 H	274	40.5	14.8
7	11000.00	44.3 AV	54.0	-9.7	1.54 H	274	29.5	14.8
8	#16500.00	56.7 PK	68.2	-11.5	1.62 H	54	41.4	15.3

Remarks:

1. Emission Level(dBuV/m) = Raw Value(dBuV) + Correction Factor(dB/m)
2. Correction Factor(dB/m) = Antenna Factor(dB/m) + Cable Factor(dB) – Pre-Amplifier Factor(dB)
3. Margin value = Emission Level – Limit value
4. The other emission levels were very low against the limit.
5. " * " : Fundamental frequency, the limit was restricted at the RF Output Power.
6. " # " : The radiated frequency is out of the restricted band.

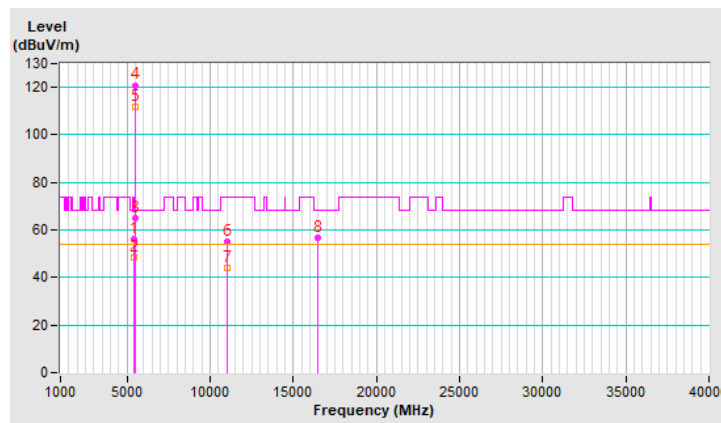

RF Mode	TX 802.11ax (HE20)	Channel	CH 100 : 5500 MHz
Frequency Range	1 GHz ~ 40 GHz	Detector Function & Bandwidth	(PK) RB = 1 MHz, VB = 3 MHz (AV) RB = 1 MHz, VB = 10 Hz
Input Power	120 Vac, 60 Hz	Environmental Conditions	20°C, 70% RH
Tested By	Ryan Du		

Antenna Polarity & Test Distance : Vertical at 3 m								
No	Frequency (MHz)	Emission Level (dBuV/m)	Limit (dBuV/m)	Margin (dB)	Antenna Height (m)	Table Angle (Degree)	Raw Value (dBuV)	Correction Factor (dB/m)
1	5460.00	61.2 PK	74.0	-12.8	1.61 V	259	56.4	4.8
2	5460.00	49.2 AV	54.0	-4.8	1.61 V	259	44.4	4.8
3	#5470.00	67.4 PK	68.2	-0.8	1.61 V	259	62.6	4.8
4	*5500.00	124.2 PK			1.61 V	259	119.4	4.8
5	*5500.00	115.5 AV			1.61 V	259	110.7	4.8
6	11000.00	55.6 PK	74.0	-18.4	1.90 V	320	40.8	14.8
7	11000.00	44.5 AV	54.0	-9.5	1.90 V	320	29.7	14.8
8	#16500.00	57.1 PK	68.2	-11.1	1.41 V	87	41.8	15.3

Remarks:

1. Emission Level(dBuV/m) = Raw Value(dBuV) + Correction Factor(dB/m)
2. Correction Factor(dB/m) = Antenna Factor(dB/m) + Cable Factor(dB) – Pre-Amplifier Factor(dB)
3. Margin value = Emission Level – Limit value
4. The other emission levels were very low against the limit.
5. " * ": Fundamental frequency, the limit was restricted at the RF Output Power.
6. " # ": The radiated frequency is out of the restricted band.

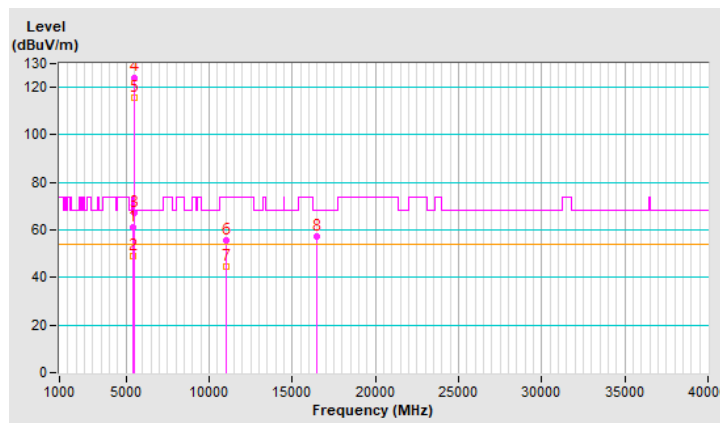

RF Mode	TX 802.11ax (HE20)	Channel	CH 116 : 5580 MHz
Frequency Range	1 GHz ~ 40 GHz	Detector Function & Bandwidth	(PK) RB = 1 MHz, VB = 3 MHz (AV) RB = 1 MHz, VB = 10 Hz
Input Power	120 Vac, 60 Hz	Environmental Conditions	20°C, 70% RH
Tested By	Ryan Du		

Antenna Polarity & Test Distance : Horizontal at 3 m

No	Frequency (MHz)	Emission Level (dBuV/m)	Limit (dBuV/m)	Margin (dB)	Antenna Height (m)	Table Angle (Degree)	Raw Value (dBuV)	Correction Factor (dB/m)
1	*5580.00	121.4 PK			1.65 H	76	116.6	4.8
2	*5580.00	112.1 AV			1.65 H	76	107.3	4.8
3	11160.00	55.8 PK	74.0	-18.2	1.50 H	274	41.2	14.6
4	11160.00	45.0 AV	54.0	-9.0	1.50 H	274	30.4	14.6
5	#16740.00	56.8 PK	68.2	-11.4	1.66 H	54	40.0	16.8

Remarks:

1. Emission Level(dBuV/m) = Raw Value(dBuV) + Correction Factor(dB/m)
2. Correction Factor(dB/m) = Antenna Factor(dB/m) + Cable Factor(dB) – Pre-Amplifier Factor(dB)
3. Margin value = Emission Level – Limit value
4. The other emission levels were very low against the limit.
5. " * " : Fundamental frequency, the limit was restricted at the RF Output Power.
6. " # " : The radiated frequency is out of the restricted band.

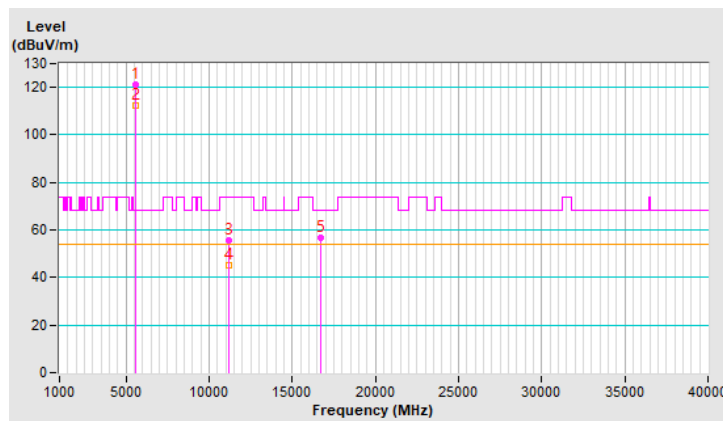

RF Mode	TX 802.11ax (HE20)	Channel	CH 116 : 5580 MHz
Frequency Range	1 GHz ~ 40 GHz	Detector Function & Bandwidth	(PK) RB = 1 MHz, VB = 3 MHz (AV) RB = 1 MHz, VB = 10 Hz
Input Power	120 Vac, 60 Hz	Environmental Conditions	20°C, 70% RH
Tested By	Ryan Du		

Antenna Polarity & Test Distance : Vertical at 3 m								
No	Frequency (MHz)	Emission Level (dBuV/m)	Limit (dBuV/m)	Margin (dB)	Antenna Height (m)	Table Angle (Degree)	Raw Value (dBuV)	Correction Factor (dB/m)
1	*5580.00	122.3 PK			1.61 V	259	117.5	4.8
2	*5580.00	113.8 AV			1.61 V	259	109.0	4.8
3	11160.00	55.9 PK	74.0	-18.1	1.95 V	328	41.3	14.6
4	11160.00	44.7 AV	54.0	-9.3	1.95 V	328	30.1	14.6
5	#16740.00	56.5 PK	68.2	-11.7	1.31 V	89	39.7	16.8

Remarks:

1. Emission Level(dBuV/m) = Raw Value(dBuV) + Correction Factor(dB/m)
2. Correction Factor(dB/m) = Antenna Factor(dB/m) + Cable Factor(dB) – Pre-Amplifier Factor(dB)
3. Margin value = Emission Level – Limit value
4. The other emission levels were very low against the limit.
5. " * " : Fundamental frequency, the limit was restricted at the RF Output Power.
6. " # " : The radiated frequency is out of the restricted band.

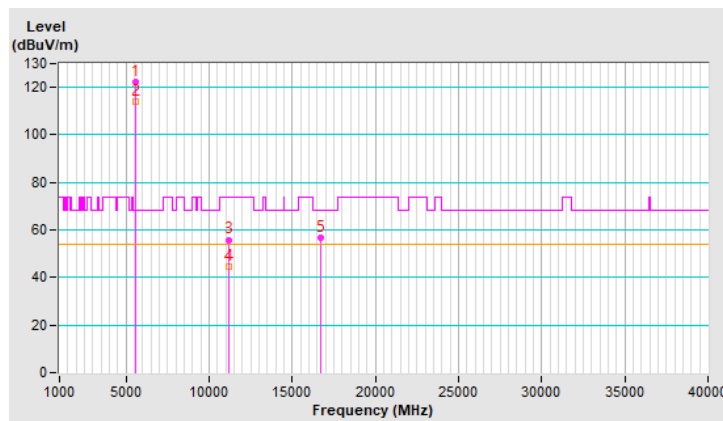

RF Mode	TX 802.11ax (HE20)	Channel	CH 140 : 5700 MHz
Frequency Range	1 GHz ~ 40 GHz	Detector Function & Bandwidth	(PK) RB = 1 MHz, VB = 3 MHz (AV) RB = 1 MHz, VB = 10 Hz
Input Power	120 Vac, 60 Hz	Environmental Conditions	20°C, 70% RH
Tested By	Ryan Du		

Antenna Polarity & Test Distance : Horizontal at 3 m

No	Frequency (MHz)	Emission Level (dBuV/m)	Limit (dBuV/m)	Margin (dB)	Antenna Height (m)	Table Angle (Degree)	Raw Value (dBuV)	Correction Factor (dB/m)
1	*5700.00	121.4 PK			1.66 H	75	116.7	4.7
2	*5700.00	112.1 AV			1.66 H	75	107.4	4.7
3	#5725.00	62.4 PK	68.2	-5.8	1.66 H	75	57.5	4.9
4	11400.00	56.2 PK	74.0	-17.8	1.52 H	283	40.8	15.4
5	11400.00	45.2 AV	54.0	-8.8	1.52 H	283	29.8	15.4
6	#17100.00	56.7 PK	68.2	-11.5	1.64 H	47	38.2	18.5

Remarks:

1. Emission Level(dBuV/m) = Raw Value(dBuV) + Correction Factor(dB/m)
2. Correction Factor(dB/m) = Antenna Factor(dB/m) + Cable Factor(dB) – Pre-Amplifier Factor(dB)
3. Margin value = Emission Level – Limit value
4. The other emission levels were very low against the limit.
5. " * " : Fundamental frequency, the limit was restricted at the RF Output Power.
6. " # " : The radiated frequency is out of the restricted band.

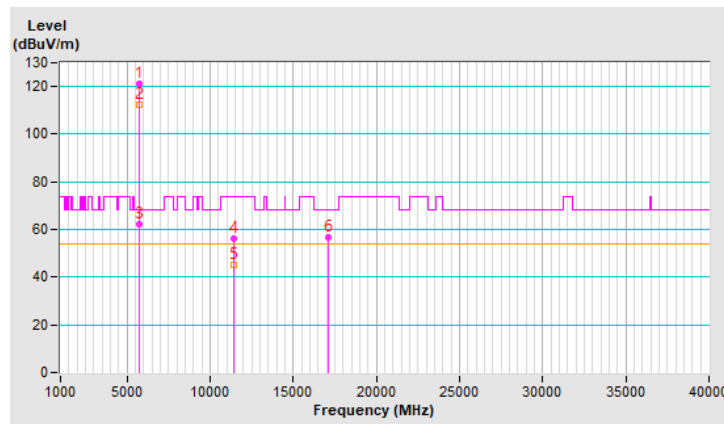

RF Mode	TX 802.11ax (HE20)	Channel	CH 140 : 5700 MHz
Frequency Range	1 GHz ~ 40 GHz	Detector Function & Bandwidth	(PK) RB = 1 MHz, VB = 3 MHz (AV) RB = 1 MHz, VB = 10 Hz
Input Power	120 Vac, 60 Hz	Environmental Conditions	20°C, 70% RH
Tested By	Ryan Du		

Antenna Polarity & Test Distance : Vertical at 3 m								
No	Frequency (MHz)	Emission Level (dBuV/m)	Limit (dBuV/m)	Margin (dB)	Antenna Height (m)	Table Angle (Degree)	Raw Value (dBuV)	Correction Factor (dB/m)
1	*5700.00	122.7 PK			1.63 V	257	118.0	4.7
2	*5700.00	113.9 AV			1.63 V	257	109.2	4.7
3	#5725.00	67.5 PK	68.2	-0.7	1.63 V	257	62.6	4.9
4	11400.00	55.2 PK	74.0	-18.8	1.91 V	329	39.8	15.4
5	11400.00	44.0 AV	54.0	-10.0	1.91 V	329	28.6	15.4
6	#17100.00	56.2 PK	68.2	-12.0	1.37 V	91	37.7	18.5

Remarks:

1. Emission Level(dBuV/m) = Raw Value(dBuV) + Correction Factor(dB/m)
2. Correction Factor(dB/m) = Antenna Factor(dB/m) + Cable Factor(dB) – Pre-Amplifier Factor(dB)
3. Margin value = Emission Level – Limit value
4. The other emission levels were very low against the limit.
5. " * " : Fundamental frequency, the limit was restricted at the RF Output Power.
6. " # " : The radiated frequency is out of the restricted band.

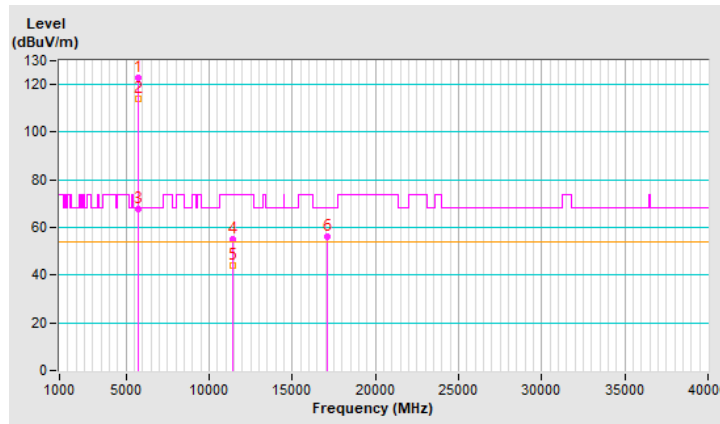

RF Mode	TX 802.11ax (HE20)	Channel	CH 144 : 5720 MHz
Frequency Range	1 GHz ~ 40 GHz	Detector Function & Bandwidth	(PK) RB = 1 MHz, VB = 3 MHz (AV) RB = 1 MHz, VB = 10 Hz
Input Power	120 Vac, 60 Hz	Environmental Conditions	20°C, 70% RH
Tested By	Ryan Du		

Antenna Polarity & Test Distance : Horizontal at 3 m

No	Frequency (MHz)	Emission Level (dBuV/m)	Limit (dBuV/m)	Margin (dB)	Antenna Height (m)	Table Angle (Degree)	Raw Value (dBuV)	Correction Factor (dB/m)
1	*5720.00	120.8 PK			1.63 H	75	116.0	4.8
2	*5720.00	111.5 AV			1.63 H	75	106.7	4.8
3	11440.00	56.2 PK	74.0	-17.8	1.45 H	261	40.9	15.3
4	11440.00	45.1 AV	54.0	-8.9	1.45 H	261	29.8	15.3
5	#17160.00	56.4 PK	68.2	-11.8	1.66 H	53	38.1	18.3

Remarks:

1. Emission Level(dBuV/m) = Raw Value(dBuV) + Correction Factor(dB/m)
2. Correction Factor(dB/m) = Antenna Factor(dB/m) + Cable Factor(dB) – Pre-Amplifier Factor(dB)
3. Margin value = Emission Level – Limit value
4. The other emission levels were very low against the limit.
5. " * " : Fundamental frequency, the limit was restricted at the RF Output Power.
6. " # " : The radiated frequency is out of the restricted band.

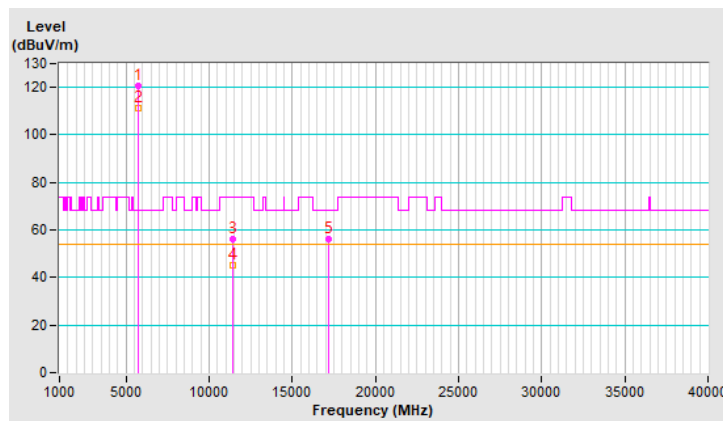

RF Mode	TX 802.11ax (HE20)	Channel	CH 144 : 5720 MHz
Frequency Range	1 GHz ~ 40 GHz	Detector Function & Bandwidth	(PK) RB = 1 MHz, VB = 3 MHz (AV) RB = 1 MHz, VB = 10 Hz
Input Power	120 Vac, 60 Hz	Environmental Conditions	20°C, 70% RH
Tested By	Ryan Du		

Antenna Polarity & Test Distance : Vertical at 3 m								
No	Frequency (MHz)	Emission Level (dBuV/m)	Limit (dBuV/m)	Margin (dB)	Antenna Height (m)	Table Angle (Degree)	Raw Value (dBuV)	Correction Factor (dB/m)
1	*5720.00	122.5 PK			1.69 V	259	117.7	4.8
2	*5720.00	113.7 AV			1.69 V	259	108.9	4.8
3	11440.00	55.7 PK	74.0	-18.3	1.92 V	315	40.4	15.3
4	11440.00	44.6 AV	54.0	-9.4	1.92 V	315	29.3	15.3
5	#17160.00	56.6 PK	68.2	-11.6	1.35 V	89	38.3	18.3

Remarks:

1. Emission Level(dBuV/m) = Raw Value(dBuV) + Correction Factor(dB/m)
2. Correction Factor(dB/m) = Antenna Factor(dB/m) + Cable Factor(dB) – Pre-Amplifier Factor(dB)
3. Margin value = Emission Level – Limit value
4. The other emission levels were very low against the limit.
5. " * " : Fundamental frequency, the limit was restricted at the RF Output Power.
6. " # " : The radiated frequency is out of the restricted band.

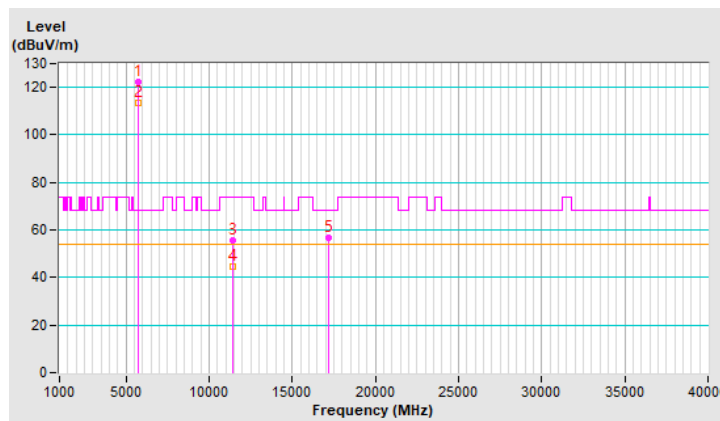

RF Mode	TX 802.11ax (HE40)	Channel	CH 54 : 5270 MHz
Frequency Range	1 GHz ~ 40 GHz	Detector Function & Bandwidth	(PK) RB = 1 MHz, VB = 3 MHz (AV) RB = 1 MHz, VB = 10 Hz
Input Power	120 Vac, 60 Hz	Environmental Conditions	20°C, 70% RH
Tested By	Ryan Du		

Antenna Polarity & Test Distance : Horizontal at 3 m								
No	Frequency (MHz)	Emission Level (dBuV/m)	Limit (dBuV/m)	Margin (dB)	Antenna Height (m)	Table Angle (Degree)	Raw Value (dBuV)	Correction Factor (dB/m)
1	*5270.00	118.6 PK			1.65 H	83	114.3	4.3
2	*5270.00	109.4 AV			1.65 H	83	105.1	4.3
3	5353.90	60.4 PK	74.0	-13.6	1.65 H	83	55.8	4.6
4	5353.90	48.9 AV	54.0	-5.1	1.65 H	83	44.3	4.6
5	#10540.00	54.7 PK	68.2	-13.5	1.50 H	267	40.3	14.4
6	15810.00	56.7 PK	74.0	-17.3	1.61 H	34	43.1	13.6
7	15810.00	44.5 AV	54.0	-9.5	1.61 H	34	30.9	13.6

Remarks:

1. Emission Level(dBuV/m) = Raw Value(dBuV) + Correction Factor(dB/m)
2. Correction Factor(dB/m) = Antenna Factor(dB/m) + Cable Factor(dB) – Pre-Amplifier Factor(dB)
3. Margin value = Emission Level – Limit value
4. The other emission levels were very low against the limit.
5. " * " : Fundamental frequency, the limit was restricted at the RF Output Power.
6. " # " : The radiated frequency is out of the restricted band.

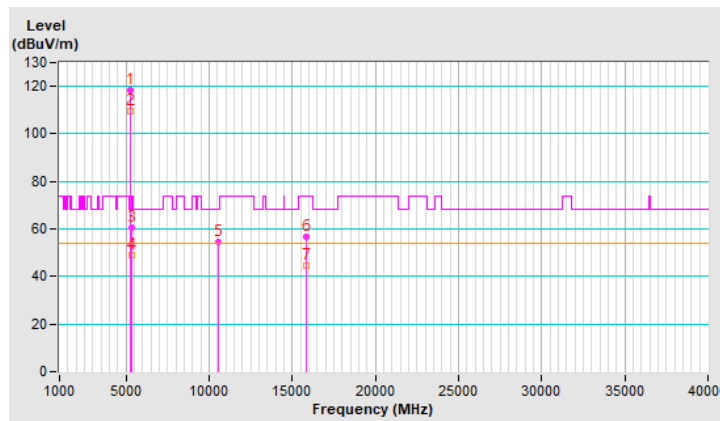

RF Mode	TX 802.11ax (HE40)	Channel	CH 54 : 5270 MHz
Frequency Range	1 GHz ~ 40 GHz	Detector Function & Bandwidth	(PK) RB = 1 MHz, VB = 3 MHz (AV) RB = 1 MHz, VB = 10 Hz
Input Power	120 Vac, 60 Hz	Environmental Conditions	20°C, 70% RH
Tested By	Ryan Du		

Antenna Polarity & Test Distance : Vertical at 3 m								
No	Frequency (MHz)	Emission Level (dBuV/m)	Limit (dBuV/m)	Margin (dB)	Antenna Height (m)	Table Angle (Degree)	Raw Value (dBuV)	Correction Factor (dB/m)
1	*5270.00	123.7 PK			2.19 V	242	119.4	4.3
2	*5270.00	114.6 AV			2.19 V	242	110.3	4.3
3	5350.00	66.9 PK	74.0	-7.1	2.19 V	242	62.3	4.6
4	5350.00	53.4 AV	54.0	-0.6	2.19 V	242	48.8	4.6
5	#10540.00	55.3 PK	68.2	-12.9	1.97 V	343	40.9	14.4
6	15810.00	56.4 PK	74.0	-17.6	1.33 V	77	42.8	13.6
7	15810.00	46.2 AV	54.0	-7.8	1.33 V	77	32.6	13.6

Remarks:

1. Emission Level(dBuV/m) = Raw Value(dBuV) + Correction Factor(dB/m)
2. Correction Factor(dB/m) = Antenna Factor(dB/m) + Cable Factor(dB) – Pre-Amplifier Factor(dB)
3. Margin value = Emission Level – Limit value
4. The other emission levels were very low against the limit.
5. " * " : Fundamental frequency, the limit was restricted at the RF Output Power.
6. " # " : The radiated frequency is out of the restricted band.

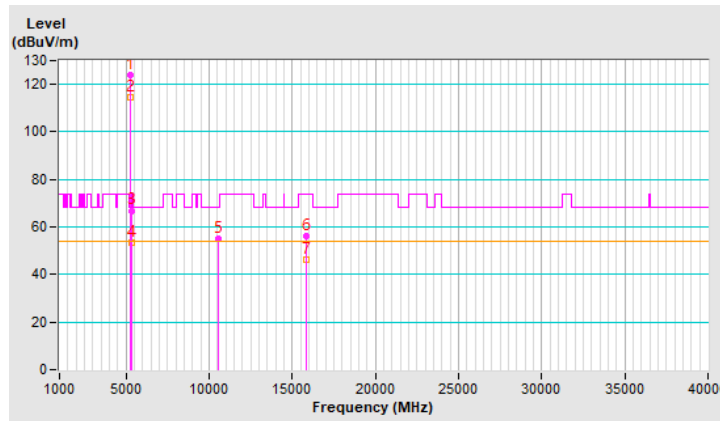

RF Mode	TX 802.11ax (HE40)	Channel	CH 62 : 5310 MHz
Frequency Range	1 GHz ~ 40 GHz	Detector Function & Bandwidth	(PK) RB = 1 MHz, VB = 3 MHz (AV) RB = 1 MHz, VB = 10 Hz
Input Power	120 Vac, 60 Hz	Environmental Conditions	20°C, 70% RH
Tested By	Ryan Du		

Antenna Polarity & Test Distance : Horizontal at 3 m								
No	Frequency (MHz)	Emission Level (dBuV/m)	Limit (dBuV/m)	Margin (dB)	Antenna Height (m)	Table Angle (Degree)	Raw Value (dBuV)	Correction Factor (dB/m)
1	*5310.00	113.1 PK			1.42 H	55	108.7	4.4
2	*5310.00	103.9 AV			1.42 H	55	99.5	4.4
3	5352.22	56.0 PK	74.0	-18.0	1.42 H	55	51.4	4.6
4	5352.22	47.0 AV	54.0	-7.0	1.42 H	55	42.4	4.6
5	10620.00	55.6 PK	74.0	-18.4	1.48 H	277	41.3	14.3
6	10620.00	44.7 AV	54.0	-9.3	1.48 H	277	30.4	14.3
7	15930.00	55.7 PK	74.0	-18.3	1.66 H	44	41.7	14.0
8	15930.00	43.7 AV	54.0	-10.3	1.66 H	44	29.7	14.0

Remarks:

1. Emission Level(dBuV/m) = Raw Value(dBuV) + Correction Factor(dB/m)
2. Correction Factor(dB/m) = Antenna Factor(dB/m) + Cable Factor(dB) – Pre-Amplifier Factor(dB)
3. Margin value = Emission Level – Limit value
4. The other emission levels were very low against the limit.
5. " * ": Fundamental frequency, the limit was restricted at the RF Output Power.

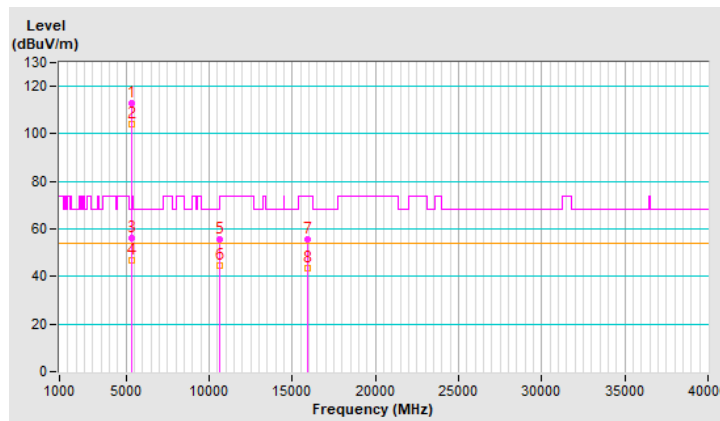

RF Mode	TX 802.11ax (HE40)	Channel	CH 62 : 5310 MHz
Frequency Range	1 GHz ~ 40 GHz	Detector Function & Bandwidth	(PK) RB = 1 MHz, VB = 3 MHz (AV) RB = 1 MHz, VB = 10 Hz
Input Power	120 Vac, 60 Hz	Environmental Conditions	20°C, 70% RH
Tested By	Ryan Du		

Antenna Polarity & Test Distance : Vertical at 3 m								
No	Frequency (MHz)	Emission Level (dBuV/m)	Limit (dBuV/m)	Margin (dB)	Antenna Height (m)	Table Angle (Degree)	Raw Value (dBuV)	Correction Factor (dB/m)
1	*5310.00	117.5 PK			2.08 V	245	113.1	4.4
2	*5310.00	109.0 AV			2.08 V	245	104.6	4.4
3	5350.00	62.6 PK	74.0	-11.4	2.08 V	245	58.0	4.6
4	5350.00	53.2 AV	54.0	-0.8	2.08 V	245	48.6	4.6
5	10620.00	55.1 PK	74.0	-18.9	2.05 V	327	40.8	14.3
6	10620.00	44.4 AV	54.0	-9.6	2.05 V	327	30.1	14.3
7	15930.00	56.7 PK	74.0	-17.3	1.34 V	76	42.7	14.0
8	15930.00	46.2 AV	54.0	-7.8	1.34 V	76	32.2	14.0

Remarks:

1. Emission Level(dBuV/m) = Raw Value(dBuV) + Correction Factor(dB/m)
2. Correction Factor(dB/m) = Antenna Factor(dB/m) + Cable Factor(dB) – Pre-Amplifier Factor(dB)
3. Margin value = Emission Level – Limit value
4. The other emission levels were very low against the limit.
5. " * ": Fundamental frequency, the limit was restricted at the RF Output Power.

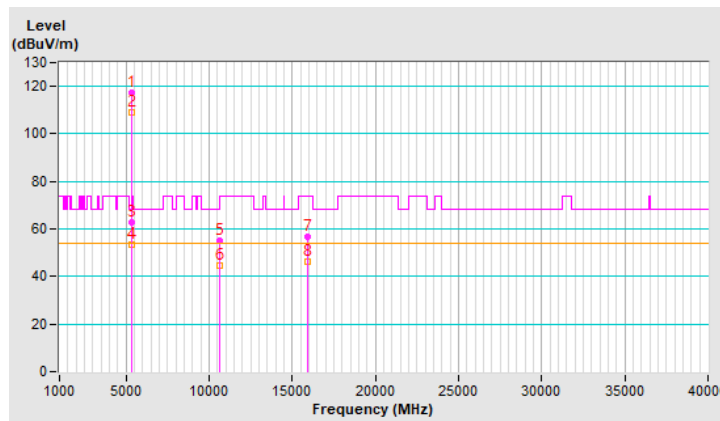

RF Mode	TX 802.11ax (HE40)	Channel	CH 102 : 5510 MHz
Frequency Range	1 GHz ~ 40 GHz	Detector Function & Bandwidth	(PK) RB = 1 MHz, VB = 3 MHz (AV) RB = 1 MHz, VB = 10 Hz
Input Power	120 Vac, 60 Hz	Environmental Conditions	20°C, 70% RH
Tested By	Ryan Du		

Antenna Polarity & Test Distance : Horizontal at 3 m

No	Frequency (MHz)	Emission Level (dBuV/m)	Limit (dBuV/m)	Margin (dB)	Antenna Height (m)	Table Angle (Degree)	Raw Value (dBuV)	Correction Factor (dB/m)
1	5457.24	53.8 PK	74.0	-20.2	1.18 H	53	49.0	4.8
2	5457.24	44.6 AV	54.0	-9.4	1.18 H	53	39.8	4.8
3	#5467.41	59.1 PK	68.2	-9.1	1.18 H	53	54.3	4.8
4	*5510.00	115.5 PK			1.18 H	53	110.6	4.9
5	*5510.00	105.6 AV			1.18 H	53	100.7	4.9
6	11020.00	55.1 PK	74.0	-18.9	1.50 H	275	40.4	14.7
7	11020.00	44.3 AV	54.0	-9.7	1.50 H	275	29.6	14.7
8	#16530.00	56.7 PK	68.2	-11.5	1.55 H	32	41.4	15.3

Remarks:

1. Emission Level(dBuV/m) = Raw Value(dBuV) + Correction Factor(dB/m)
2. Correction Factor(dB/m) = Antenna Factor(dB/m) + Cable Factor(dB) – Pre-Amplifier Factor(dB)
3. Margin value = Emission Level – Limit value
4. The other emission levels were very low against the limit.
5. " * " : Fundamental frequency, the limit was restricted at the RF Output Power.
6. " # " : The radiated frequency is out of the restricted band.

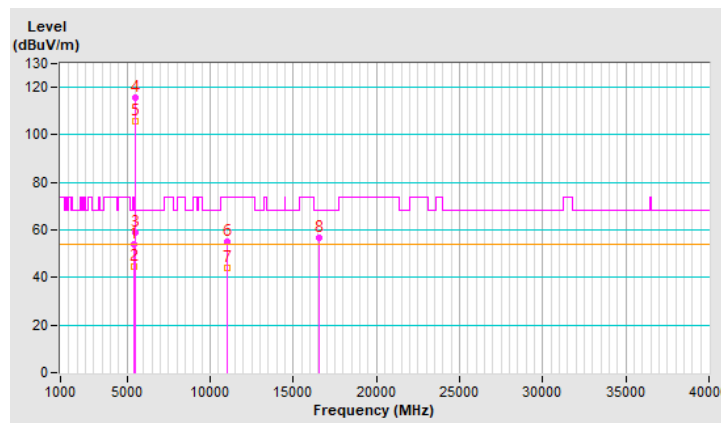

RF Mode	TX 802.11ax (HE40)	Channel	CH 102 : 5510 MHz
Frequency Range	1 GHz ~ 40 GHz	Detector Function & Bandwidth	(PK) RB = 1 MHz, VB = 3 MHz (AV) RB = 1 MHz, VB = 10 Hz
Input Power	120 Vac, 60 Hz	Environmental Conditions	20°C, 70% RH
Tested By	Ryan Du		

Antenna Polarity & Test Distance : Vertical at 3 m								
No	Frequency (MHz)	Emission Level (dBuV/m)	Limit (dBuV/m)	Margin (dB)	Antenna Height (m)	Table Angle (Degree)	Raw Value (dBuV)	Correction Factor (dB/m)
1	5460.00	59.9 PK	74.0	-14.1	1.82 V	247	55.1	4.8
2	5460.00	48.7 AV	54.0	-5.3	1.82 V	247	43.9	4.8
3	#5470.00	67.5 PK	68.2	-0.7	1.82 V	247	62.7	4.8
4	*5510.00	120.1 PK			1.82 V	247	115.2	4.9
5	*5510.00	111.2 AV			1.82 V	247	106.3	4.9
6	11020.00	55.8 PK	74.0	-18.2	1.98 V	320	41.1	14.7
7	11020.00	45.0 AV	54.0	-9.0	1.98 V	320	30.3	14.7
8	#16530.00	56.3 PK	68.2	-11.9	1.40 V	74	41.0	15.3

Remarks:

1. Emission Level(dBuV/m) = Raw Value(dBuV) + Correction Factor(dB/m)
2. Correction Factor(dB/m) = Antenna Factor(dB/m) + Cable Factor(dB) – Pre-Amplifier Factor(dB)
3. Margin value = Emission Level – Limit value
4. The other emission levels were very low against the limit.
5. " * ": Fundamental frequency, the limit was restricted at the RF Output Power.
6. " # ": The radiated frequency is out of the restricted band.

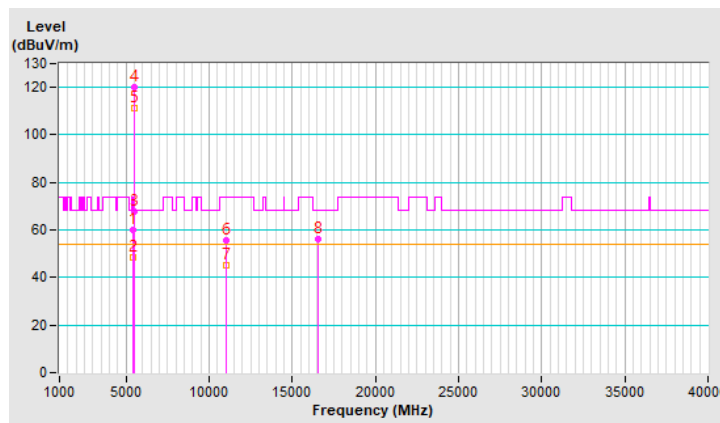

RF Mode	TX 802.11ax (HE40)	Channel	CH 110 : 5550 MHz
Frequency Range	1 GHz ~ 40 GHz	Detector Function & Bandwidth	(PK) RB = 1 MHz, VB = 3 MHz (AV) RB = 1 MHz, VB = 10 Hz
Input Power	120 Vac, 60 Hz	Environmental Conditions	20°C, 70% RH
Tested By	Ryan Du		

Antenna Polarity & Test Distance : Horizontal at 3 m

No	Frequency (MHz)	Emission Level (dBuV/m)	Limit (dBuV/m)	Margin (dB)	Antenna Height (m)	Table Angle (Degree)	Raw Value (dBuV)	Correction Factor (dB/m)
1	*5550.00	116.1 PK			1.65 H	94	111.3	4.8
2	*5550.00	106.1 AV			1.65 H	94	101.3	4.8
3	11100.00	54.8 PK	74.0	-19.2	1.57 H	274	40.3	14.5
4	11100.00	43.9 AV	54.0	-10.1	1.57 H	274	29.4	14.5
5	#16650.00	56.3 PK	68.2	-11.9	1.55 H	42	40.0	16.3

Remarks:

1. Emission Level(dBuV/m) = Raw Value(dBuV) + Correction Factor(dB/m)
2. Correction Factor(dB/m) = Antenna Factor(dB/m) + Cable Factor(dB) – Pre-Amplifier Factor(dB)
3. Margin value = Emission Level – Limit value
4. The other emission levels were very low against the limit.
5. " * " : Fundamental frequency, the limit was restricted at the RF Output Power.
6. " # " : The radiated frequency is out of the restricted band.

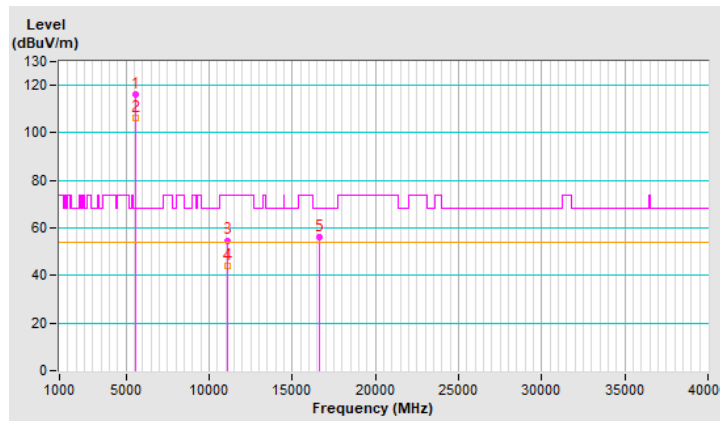

RF Mode	TX 802.11ax (HE40)	Channel	CH 110 : 5550 MHz
Frequency Range	1 GHz ~ 40 GHz	Detector Function & Bandwidth	(PK) RB = 1 MHz, VB = 3 MHz (AV) RB = 1 MHz, VB = 10 Hz
Input Power	120 Vac, 60 Hz	Environmental Conditions	20°C, 70% RH
Tested By	Ryan Du		

Antenna Polarity & Test Distance : Vertical at 3 m								
No	Frequency (MHz)	Emission Level (dBuV/m)	Limit (dBuV/m)	Margin (dB)	Antenna Height (m)	Table Angle (Degree)	Raw Value (dBuV)	Correction Factor (dB/m)
1	*5550.00	120.2 PK			1.77 V	249	115.4	4.8
2	*5550.00	111.0 AV			1.77 V	249	106.2	4.8
3	11100.00	56.2 PK	74.0	-17.8	1.95 V	320	41.7	14.5
4	11100.00	45.3 AV	54.0	-8.7	1.95 V	320	30.8	14.5
5	#16650.00	55.8 PK	68.2	-12.4	1.39 V	88	39.5	16.3

Remarks:

1. Emission Level(dBuV/m) = Raw Value(dBuV) + Correction Factor(dB/m)
2. Correction Factor(dB/m) = Antenna Factor(dB/m) + Cable Factor(dB) – Pre-Amplifier Factor(dB)
3. Margin value = Emission Level – Limit value
4. The other emission levels were very low against the limit.
5. " * " : Fundamental frequency, the limit was restricted at the RF Output Power.
6. " # " : The radiated frequency is out of the restricted band.

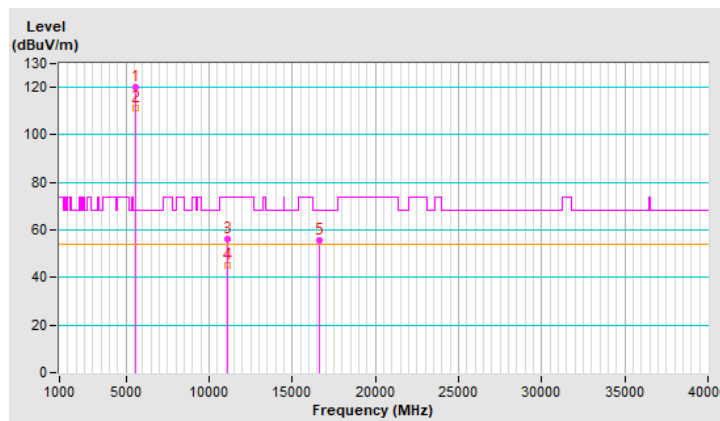

RF Mode	TX 802.11ax (HE40)	Channel	CH 134 : 5670 MHz
Frequency Range	1 GHz ~ 40 GHz	Detector Function & Bandwidth	(PK) RB = 1 MHz, VB = 3 MHz (AV) RB = 1 MHz, VB = 10 Hz
Input Power	120 Vac, 60 Hz	Environmental Conditions	20°C, 70% RH
Tested By	Ryan Du		

Antenna Polarity & Test Distance : Horizontal at 3 m								
No	Frequency (MHz)	Emission Level (dBuV/m)	Limit (dBuV/m)	Margin (dB)	Antenna Height (m)	Table Angle (Degree)	Raw Value (dBuV)	Correction Factor (dB/m)
1	*5670.00	115.6 PK			1.67 H	86	110.7	4.9
2	*5670.00	105.5 AV			1.67 H	86	100.6	4.9
3	#5725.00	55.2 PK	68.2	-13.0	1.67 H	86	50.3	4.9
4	11340.00	55.3 PK	74.0	-18.7	1.53 H	279	40.0	15.3
5	11340.00	44.5 AV	54.0	-9.5	1.53 H	279	29.2	15.3
6	#17010.00	56.2 PK	68.2	-12.0	1.61 H	43	37.9	18.3

Remarks:

1. Emission Level(dBuV/m) = Raw Value(dBuV) + Correction Factor(dB/m)
2. Correction Factor(dB/m) = Antenna Factor(dB/m) + Cable Factor(dB) – Pre-Amplifier Factor(dB)
3. Margin value = Emission Level – Limit value
4. The other emission levels were very low against the limit.
5. " * " : Fundamental frequency, the limit was restricted at the RF Output Power.
6. " # " : The radiated frequency is out of the restricted band.

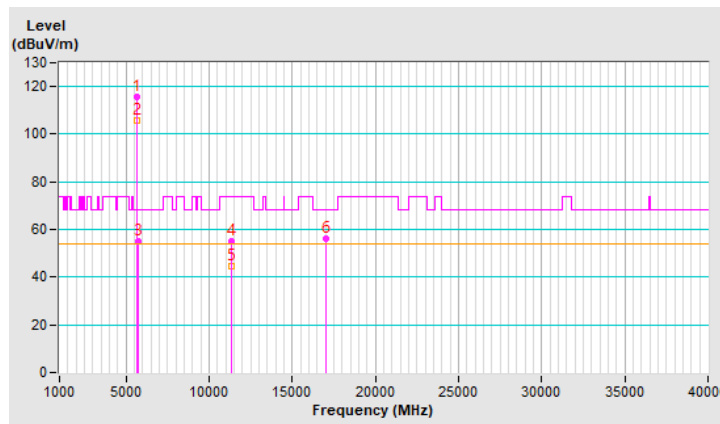

RF Mode	TX 802.11ax (HE40)	Channel	CH 134 : 5670 MHz
Frequency Range	1 GHz ~ 40 GHz	Detector Function & Bandwidth	(PK) RB = 1 MHz, VB = 3 MHz (AV) RB = 1 MHz, VB = 10 Hz
Input Power	120 Vac, 60 Hz	Environmental Conditions	20°C, 70% RH
Tested By	Ryan Du		

Antenna Polarity & Test Distance : Vertical at 3 m								
No	Frequency (MHz)	Emission Level (dBuV/m)	Limit (dBuV/m)	Margin (dB)	Antenna Height (m)	Table Angle (Degree)	Raw Value (dBuV)	Correction Factor (dB/m)
1	*5670.00	119.9 PK			1.58 V	273	115.0	4.9
2	*5670.00	110.8 AV			1.58 V	273	105.9	4.9
3	#5725.00	55.4 PK	68.2	-12.8	1.58 V	273	50.5	4.9
4	11340.00	55.4 PK	74.0	-18.6	1.96 V	344	40.1	15.3
5	11340.00	44.4 AV	54.0	-9.6	1.96 V	344	29.1	15.3
6	#17010.00	56.2 PK	68.2	-12.0	1.38 V	104	37.9	18.3

Remarks:

1. Emission Level(dBuV/m) = Raw Value(dBuV) + Correction Factor(dB/m)
2. Correction Factor(dB/m) = Antenna Factor(dB/m) + Cable Factor(dB) – Pre-Amplifier Factor(dB)
3. Margin value = Emission Level – Limit value
4. The other emission levels were very low against the limit.
5. " * " : Fundamental frequency, the limit was restricted at the RF Output Power.
6. " # " : The radiated frequency is out of the restricted band.

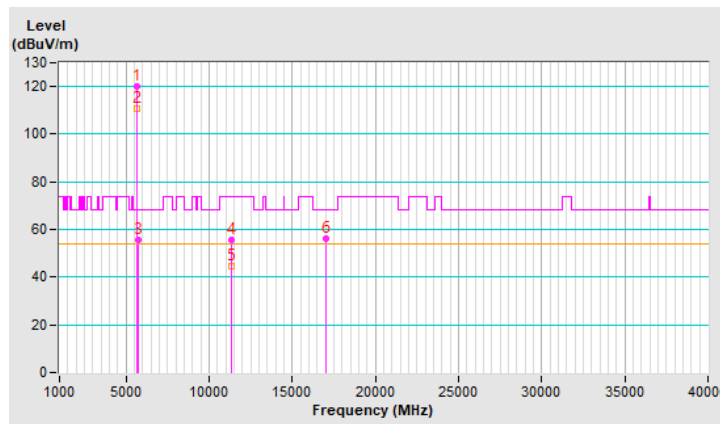

RF Mode	TX 802.11ax (HE40)	Channel	CH 142 : 5710 MHz
Frequency Range	1 GHz ~ 40 GHz	Detector Function & Bandwidth	(PK) RB = 1 MHz, VB = 3 MHz (AV) RB = 1 MHz, VB = 10 Hz
Input Power	120 Vac, 60 Hz	Environmental Conditions	20°C, 70% RH
Tested By	Ryan Du		

Antenna Polarity & Test Distance : Horizontal at 3 m

No	Frequency (MHz)	Emission Level (dBuV/m)	Limit (dBuV/m)	Margin (dB)	Antenna Height (m)	Table Angle (Degree)	Raw Value (dBuV)	Correction Factor (dB/m)
1	*5710.00	115.7 PK			1.65 H	76	110.9	4.8
2	*5710.00	105.8 AV			1.65 H	76	101.0	4.8
3	11420.00	55.3 PK	74.0	-18.7	1.51 H	286	40.0	15.3
4	11420.00	44.5 AV	54.0	-9.5	1.51 H	286	29.2	15.3
5	#17130.00	56.7 PK	68.2	-11.5	1.67 H	33	38.4	18.3

Remarks:

1. Emission Level(dBuV/m) = Raw Value(dBuV) + Correction Factor(dB/m)
2. Correction Factor(dB/m) = Antenna Factor(dB/m) + Cable Factor(dB) – Pre-Amplifier Factor(dB)
3. Margin value = Emission Level – Limit value
4. The other emission levels were very low against the limit.
5. " * " : Fundamental frequency, the limit was restricted at the RF Output Power.
6. " # " : The radiated frequency is out of the restricted band.

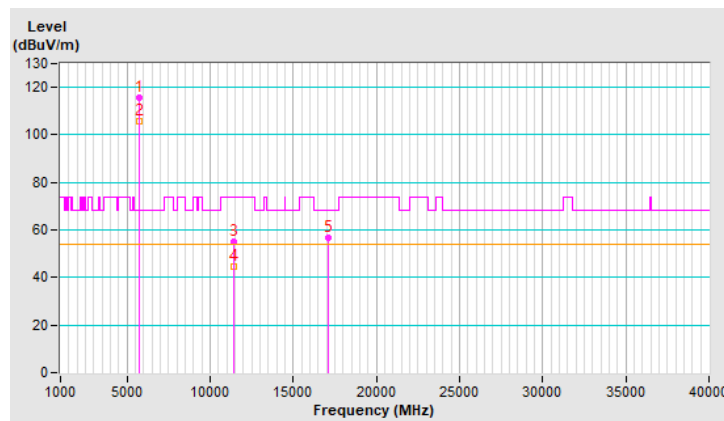

RF Mode	TX 802.11ax (HE40)	Channel	CH 142 : 5710 MHz
Frequency Range	1 GHz ~ 40 GHz	Detector Function & Bandwidth	(PK) RB = 1 MHz, VB = 3 MHz (AV) RB = 1 MHz, VB = 10 Hz
Input Power	120 Vac, 60 Hz	Environmental Conditions	20°C, 70% RH
Tested By	Ryan Du		

Antenna Polarity & Test Distance : Vertical at 3 m								
No	Frequency (MHz)	Emission Level (dBuV/m)	Limit (dBuV/m)	Margin (dB)	Antenna Height (m)	Table Angle (Degree)	Raw Value (dBuV)	Correction Factor (dB/m)
1	*5710.00	120.4 PK			1.62 V	264	115.6	4.8
2	*5710.00	111.1 AV			1.62 V	264	106.3	4.8
3	11420.00	56.2 PK	74.0	-17.8	1.95 V	343	40.9	15.3
4	11420.00	45.1 AV	54.0	-8.9	1.95 V	343	29.8	15.3
5	#17130.00	56.8 PK	68.2	-11.4	1.41 V	85	38.5	18.3

Remarks:

1. Emission Level(dBuV/m) = Raw Value(dBuV) + Correction Factor(dB/m)
2. Correction Factor(dB/m) = Antenna Factor(dB/m) + Cable Factor(dB) – Pre-Amplifier Factor(dB)
3. Margin value = Emission Level – Limit value
4. The other emission levels were very low against the limit.
5. " * " : Fundamental frequency, the limit was restricted at the RF Output Power.
6. " # " : The radiated frequency is out of the restricted band.

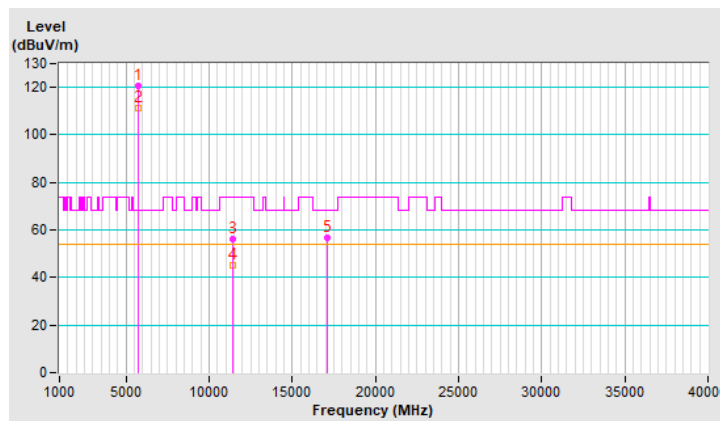

RF Mode	TX 802.11ax (HE80)	Channel	CH 58 : 5290 MHz
Frequency Range	1 GHz ~ 40 GHz	Detector Function & Bandwidth	(PK) RB = 1 MHz, VB = 3 MHz (AV) RB = 1 MHz, VB = 10 Hz
Input Power	120 Vac, 60 Hz	Environmental Conditions	20°C, 70% RH
Tested By	Ryan Du		

Antenna Polarity & Test Distance : Horizontal at 3 m

No	Frequency (MHz)	Emission Level (dBuV/m)	Limit (dBuV/m)	Margin (dB)	Antenna Height (m)	Table Angle (Degree)	Raw Value (dBuV)	Correction Factor (dB/m)
1	*5290.00	108.2 PK			1.47 H	31	103.9	4.3
2	*5290.00	98.0 AV			1.47 H	31	93.7	4.3
3	5354.21	56.6 PK	74.0	-17.4	1.47 H	31	52.0	4.6
4	5354.21	50.0 AV	54.0	-4.0	1.47 H	31	45.4	4.6
5	#10580.00	54.9 PK	68.2	-13.3	1.49 H	274	40.6	14.3
6	15870.00	56.2 PK	74.0	-17.8	1.65 H	21	42.4	13.8
7	15870.00	43.9 AV	54.0	-10.1	1.65 H	21	30.1	13.8

Remarks:

1. Emission Level(dBuV/m) = Raw Value(dBuV) + Correction Factor(dB/m)
2. Correction Factor(dB/m) = Antenna Factor(dB/m) + Cable Factor(dB) – Pre-Amplifier Factor(dB)
3. Margin value = Emission Level – Limit value
4. The other emission levels were very low against the limit.
5. " * " : Fundamental frequency, the limit was restricted at the RF Output Power.
6. " # " : The radiated frequency is out of the restricted band.

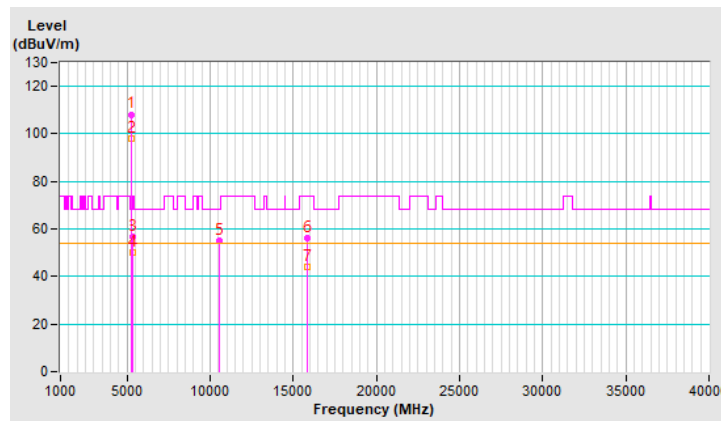

RF Mode	TX 802.11ax (HE80)	Channel	CH 58 : 5290 MHz
Frequency Range	1 GHz ~ 40 GHz	Detector Function & Bandwidth	(PK) RB = 1 MHz, VB = 3 MHz (AV) RB = 1 MHz, VB = 10 Hz
Input Power	120 Vac, 60 Hz	Environmental Conditions	20°C, 70% RH
Tested By	Ryan Du		

Antenna Polarity & Test Distance : Vertical at 3 m

No	Frequency (MHz)	Emission Level (dBuV/m)	Limit (dBuV/m)	Margin (dB)	Antenna Height (m)	Table Angle (Degree)	Raw Value (dBuV)	Correction Factor (dB/m)
1	*5290.00	110.8 PK			1.59 V	260	106.5	4.3
2	*5290.00	101.2 AV			1.59 V	260	96.9	4.3
3	5353.91	64.5 PK	74.0	-9.5	1.59 V	260	59.9	4.6
4	5353.91	53.3 AV	54.0	-0.7	1.59 V	260	48.7	4.6
5	#10580.00	55.8 PK	68.2	-12.4	1.98 V	344	41.5	14.3
6	15870.00	56.8 PK	74.0	-17.2	1.34 V	75	43.0	13.8
7	15870.00	46.3 AV	54.0	-7.7	1.34 V	75	32.5	13.8

Remarks:

1. Emission Level(dBuV/m) = Raw Value(dBuV) + Correction Factor(dB/m)
2. Correction Factor(dB/m) = Antenna Factor(dB/m) + Cable Factor(dB) – Pre-Amplifier Factor(dB)
3. Margin value = Emission Level – Limit value
4. The other emission levels were very low against the limit.
5. " * " : Fundamental frequency, the limit was restricted at the RF Output Power.
6. " # " : The radiated frequency is out of the restricted band.

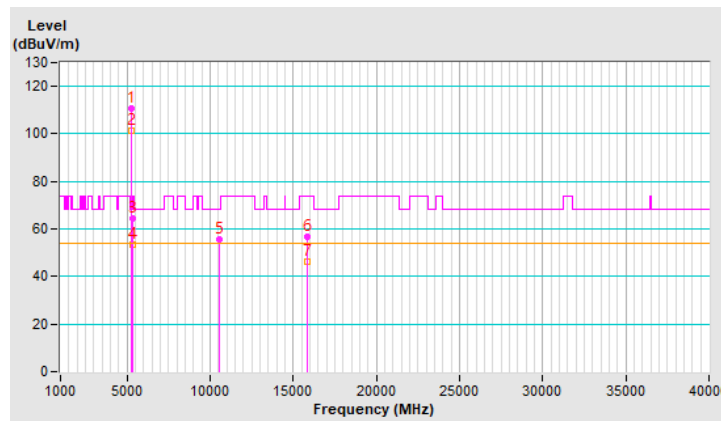

RF Mode	TX 802.11ax (HE80)	Channel	CH 106 : 5530 MHz
Frequency Range	1 GHz ~ 40 GHz	Detector Function & Bandwidth	(PK) RB = 1 MHz, VB = 3 MHz (AV) RB = 1 MHz, VB = 10 Hz
Input Power	120 Vac, 60 Hz	Environmental Conditions	20°C, 70% RH
Tested By	Ryan Du		

Antenna Polarity & Test Distance : Horizontal at 3 m

No	Frequency (MHz)	Emission Level (dBuV/m)	Limit (dBuV/m)	Margin (dB)	Antenna Height (m)	Table Angle (Degree)	Raw Value (dBuV)	Correction Factor (dB/m)
1	5456.31	56.3 PK	74.0	-17.7	1.47 H	28	51.5	4.8
2	5456.31	46.3 AV	54.0	-7.7	1.47 H	28	41.5	4.8
3	#5466.06	56.6 PK	68.2	-11.6	1.47 H	28	51.8	4.8
4	*5530.00	107.6 PK			1.47 H	28	102.8	4.8
5	*5530.00	97.8 AV			1.47 H	28	93.0	4.8
6	11060.00	55.5 PK	74.0	-18.5	1.48 H	276	40.9	14.6
7	11060.00	44.8 AV	54.0	-9.2	1.48 H	276	30.2	14.6
8	#16590.00	55.8 PK	68.2	-12.4	1.66 H	18	39.9	15.9

Remarks:

1. Emission Level(dBuV/m) = Raw Value(dBuV) + Correction Factor(dB/m)
2. Correction Factor(dB/m) = Antenna Factor(dB/m) + Cable Factor(dB) – Pre-Amplifier Factor(dB)
3. Margin value = Emission Level – Limit value
4. The other emission levels were very low against the limit.
5. " * " : Fundamental frequency, the limit was restricted at the RF Output Power.
6. " # " : The radiated frequency is out of the restricted band.

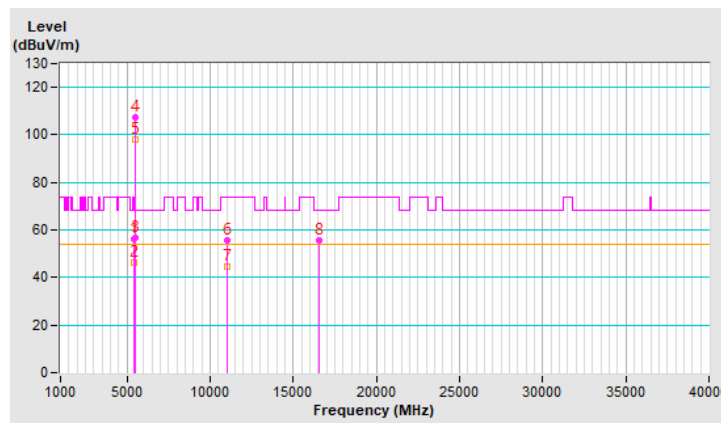

RF Mode	TX 802.11ax (HE80)	Channel	CH 106 : 5530 MHz
Frequency Range	1 GHz ~ 40 GHz	Detector Function & Bandwidth	(PK) RB = 1 MHz, VB = 3 MHz (AV) RB = 1 MHz, VB = 10 Hz
Input Power	120 Vac, 60 Hz	Environmental Conditions	20°C, 70% RH
Tested By	Ryan Du		

Antenna Polarity & Test Distance : Vertical at 3 m								
No	Frequency (MHz)	Emission Level (dBuV/m)	Limit (dBuV/m)	Margin (dB)	Antenna Height (m)	Table Angle (Degree)	Raw Value (dBuV)	Correction Factor (dB/m)
1	5457.73	62.6 PK	74.0	-11.4	1.73 V	255	57.8	4.8
2	5457.73	53.4 AV	54.0	-0.6	1.73 V	255	48.6	4.8
3	#5470.00	65.2 PK	68.2	-3.0	1.73 V	255	60.4	4.8
4	*5530.00	112.0 PK			1.73 V	255	107.2	4.8
5	*5530.00	102.5 AV			1.73 V	255	97.7	4.8
6	11060.00	55.7 PK	74.0	-18.3	1.97 V	327	41.1	14.6
7	11060.00	44.5 AV	54.0	-9.5	1.97 V	327	29.9	14.6
8	#16590.00	56.9 PK	68.2	-11.3	1.34 V	77	41.0	15.9

Remarks:

1. Emission Level(dBuV/m) = Raw Value(dBuV) + Correction Factor(dB/m)
2. Correction Factor(dB/m) = Antenna Factor(dB/m) + Cable Factor(dB) – Pre-Amplifier Factor(dB)
3. Margin value = Emission Level – Limit value
4. The other emission levels were very low against the limit.
5. " * " : Fundamental frequency, the limit was restricted at the RF Output Power.
6. " # " : The radiated frequency is out of the restricted band.

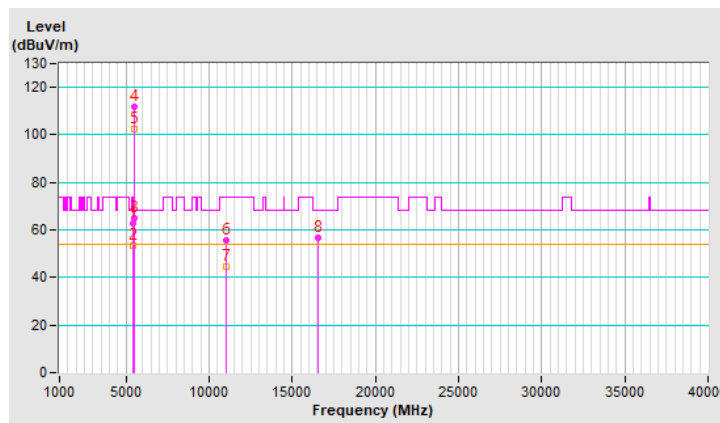

RF Mode	TX 802.11ax (HE80)	Channel	CH 122 : 5610 MHz
Frequency Range	1 GHz ~ 40 GHz	Detector Function & Bandwidth	(PK) RB = 1 MHz, VB = 3 MHz (AV) RB = 1 MHz, VB = 10 Hz
Input Power	120 Vac, 60 Hz	Environmental Conditions	20°C, 70% RH
Tested By	Ryan Du		

Antenna Polarity & Test Distance : Horizontal at 3 m

No	Frequency (MHz)	Emission Level (dBuV/m)	Limit (dBuV/m)	Margin (dB)	Antenna Height (m)	Table Angle (Degree)	Raw Value (dBuV)	Correction Factor (dB/m)
1	*5610.00	114.7 PK			1.41 H	18	109.8	4.9
2	*5610.00	105.9 AV			1.41 H	18	101.0	4.9
3	#5725.00	62.4 PK	68.2	-5.8	1.41 H	18	57.5	4.9
4	11220.00	55.6 PK	74.0	-18.4	1.53 H	268	40.9	14.7
5	11220.00	44.5 AV	54.0	-9.5	1.53 H	268	29.8	14.7
6	#16830.00	56.2 PK	68.2	-12.0	1.55 H	17	39.0	17.2

Remarks:

1. Emission Level(dBuV/m) = Raw Value(dBuV) + Correction Factor(dB/m)
2. Correction Factor(dB/m) = Antenna Factor(dB/m) + Cable Factor(dB) – Pre-Amplifier Factor(dB)
3. Margin value = Emission Level – Limit value
4. The other emission levels were very low against the limit.
5. " * " : Fundamental frequency, the limit was restricted at the RF Output Power.
6. " # " : The radiated frequency is out of the restricted band.

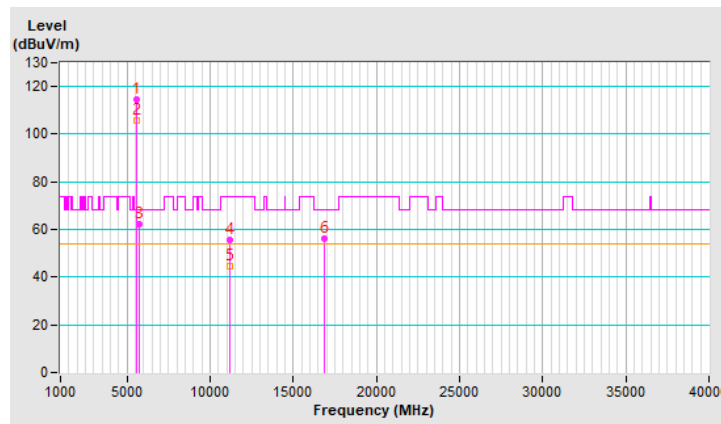

RF Mode	TX 802.11ax (HE80)	Channel	CH 122 : 5610 MHz
Frequency Range	1 GHz ~ 40 GHz	Detector Function & Bandwidth	(PK) RB = 1 MHz, VB = 3 MHz (AV) RB = 1 MHz, VB = 10 Hz
Input Power	120 Vac, 60 Hz	Environmental Conditions	20°C, 70% RH
Tested By	Ryan Du		

Antenna Polarity & Test Distance : Vertical at 3 m								
No	Frequency (MHz)	Emission Level (dBuV/m)	Limit (dBuV/m)	Margin (dB)	Antenna Height (m)	Table Angle (Degree)	Raw Value (dBuV)	Correction Factor (dB/m)
1	*5610.00	118.5 PK			1.63 V	251	113.6	4.9
2	*5610.00	110.3 AV			1.63 V	251	105.4	4.9
3	#5725.00	67.5 PK	68.2	-0.7	1.63 V	251	62.6	4.9
4	11220.00	55.3 PK	74.0	-18.7	1.96 V	337	40.6	14.7
5	11220.00	44.5 AV	54.0	-9.5	1.96 V	337	29.8	14.7
6	#16830.00	55.8 PK	68.2	-12.4	1.40 V	85	38.6	17.2

Remarks:

1. Emission Level(dBuV/m) = Raw Value(dBuV) + Correction Factor(dB/m)
2. Correction Factor(dB/m) = Antenna Factor(dB/m) + Cable Factor(dB) – Pre-Amplifier Factor(dB)
3. Margin value = Emission Level – Limit value
4. The other emission levels were very low against the limit.
5. " * " : Fundamental frequency, the limit was restricted at the RF Output Power.
6. " # " : The radiated frequency is out of the restricted band.

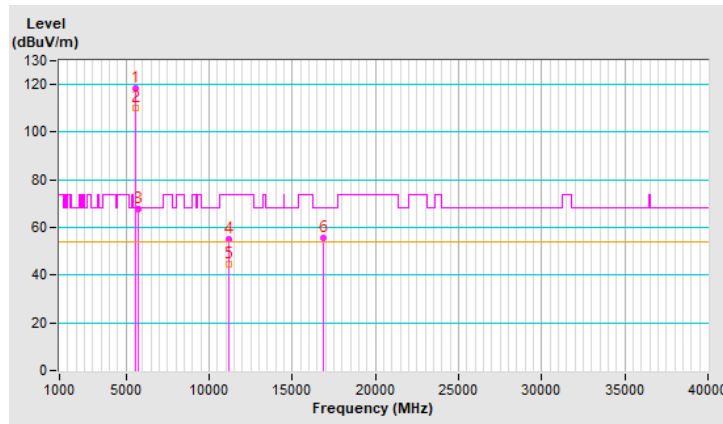

RF Mode	TX 802.11ax (HE80)	Channel	CH 138 : 5690 MHz
Frequency Range	1 GHz ~ 40 GHz	Detector Function & Bandwidth	(PK) RB = 1 MHz, VB = 3 MHz (AV) RB = 1 MHz, VB = 10 Hz
Input Power	120 Vac, 60 Hz	Environmental Conditions	20°C, 70% RH
Tested By	Ryan Du		

Antenna Polarity & Test Distance : Horizontal at 3 m

No	Frequency (MHz)	Emission Level (dBuV/m)	Limit (dBuV/m)	Margin (dB)	Antenna Height (m)	Table Angle (Degree)	Raw Value (dBuV)	Correction Factor (dB/m)
1	*5690.00	114.5 PK			1.52 H	42	109.8	4.7
2	*5690.00	105.6 AV			1.52 H	42	100.9	4.7
3	11380.00	55.3 PK	74.0	-18.7	1.55 H	283	39.9	15.4
4	11380.00	44.1 AV	54.0	-9.9	1.55 H	283	28.7	15.4
5	#17070.00	56.0 PK	68.2	-12.2	1.66 H	32	37.6	18.4

Remarks:

1. Emission Level(dBuV/m) = Raw Value(dBuV) + Correction Factor(dB/m)
2. Correction Factor(dB/m) = Antenna Factor(dB/m) + Cable Factor(dB) – Pre-Amplifier Factor(dB)
3. Margin value = Emission Level – Limit value
4. The other emission levels were very low against the limit.
5. " * " : Fundamental frequency, the limit was restricted at the RF Output Power.
6. " # " : The radiated frequency is out of the restricted band.

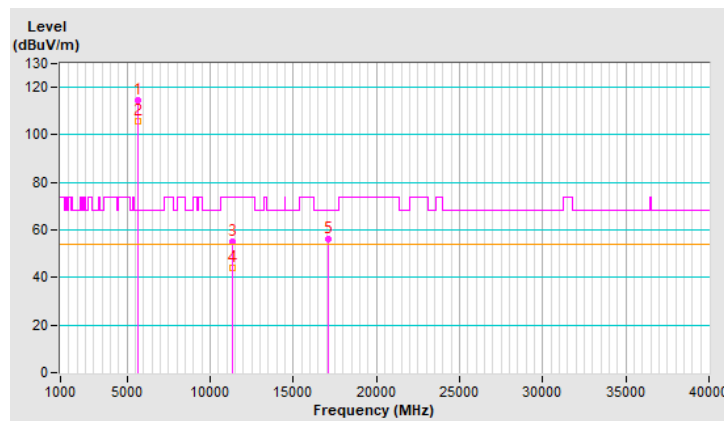

RF Mode	TX 802.11ax (HE80)	Channel	CH 138 : 5690 MHz
Frequency Range	1 GHz ~ 40 GHz	Detector Function & Bandwidth	(PK) RB = 1 MHz, VB = 3 MHz (AV) RB = 1 MHz, VB = 10 Hz
Input Power	120 Vac, 60 Hz	Environmental Conditions	20°C, 70% RH
Tested By	Ryan Du		

Antenna Polarity & Test Distance : Vertical at 3 m								
No	Frequency (MHz)	Emission Level (dBuV/m)	Limit (dBuV/m)	Margin (dB)	Antenna Height (m)	Table Angle (Degree)	Raw Value (dBuV)	Correction Factor (dB/m)
1	*5690.00	119.1 PK			1.66 V	256	114.4	4.7
2	*5690.00	110.8 AV			1.66 V	256	106.1	4.7
3	11380.00	55.6 PK	74.0	-18.4	1.98 V	347	40.2	15.4
4	11380.00	44.4 AV	54.0	-9.6	1.98 V	347	29.0	15.4
5	#17070.00	56.2 PK	68.2	-12.0	1.38 V	105	37.8	18.4

Remarks:

1. Emission Level(dBuV/m) = Raw Value(dBuV) + Correction Factor(dB/m)
2. Correction Factor(dB/m) = Antenna Factor(dB/m) + Cable Factor(dB) – Pre-Amplifier Factor(dB)
3. Margin value = Emission Level – Limit value
4. The other emission levels were very low against the limit.
5. " * " : Fundamental frequency, the limit was restricted at the RF Output Power.
6. " # " : The radiated frequency is out of the restricted band.

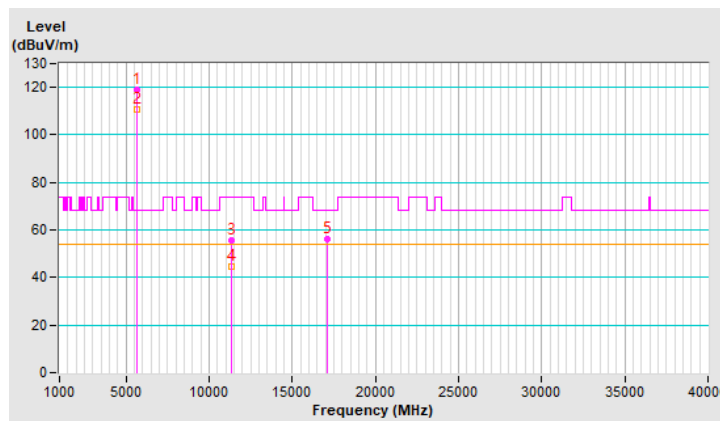

RF Mode	TX 802.11ax (HE160)	Channel	CH 50 : 5250 MHz
Frequency Range	1 GHz ~ 40 GHz	Detector Function & Bandwidth	(PK) RB = 1 MHz, VB = 3 MHz (AV) RB = 1 MHz, VB = 10 Hz
Input Power	120 Vac, 60 Hz	Environmental Conditions	20°C, 70% RH
Tested By	Ryan Du		

Antenna Polarity & Test Distance : Horizontal at 3 m

No	Frequency (MHz)	Emission Level (dBuV/m)	Limit (dBuV/m)	Margin (dB)	Antenna Height (m)	Table Angle (Degree)	Raw Value (dBuV)	Correction Factor (dB/m)
1	5131.69	57.6 PK	74.0	-16.4	1.50 H	32	52.8	4.8
2	5131.69	49.1 AV	54.0	-4.9	1.50 H	32	44.3	4.8
3	*5250.00	104.1 PK			1.50 H	32	99.7	4.4
4	*5250.00	95.1 AV			1.50 H	32	90.7	4.4
5	5361.82	57.6 PK	74.0	-16.4	1.50 H	32	53.0	4.6
6	5361.82	49.9 AV	54.0	-4.1	1.50 H	32	45.3	4.6
7	#10500.00	55.4 PK	68.2	-12.8	1.53 H	272	40.9	14.5
8	15750.00	56.6 PK	74.0	-17.4	1.59 H	26	43.1	13.5
9	15750.00	44.4 AV	54.0	-9.6	1.59 H	26	30.9	13.5

Remarks:

1. Emission Level(dBuV/m) = Raw Value(dBuV) + Correction Factor(dB/m)
2. Correction Factor(dB/m) = Antenna Factor(dB/m) + Cable Factor(dB) – Pre-Amplifier Factor(dB)
3. Margin value = Emission Level – Limit value
4. The other emission levels were very low against the limit.
5. " * " : Fundamental frequency, the limit was restricted at the RF Output Power.
6. " # " : The radiated frequency is out of the restricted band.

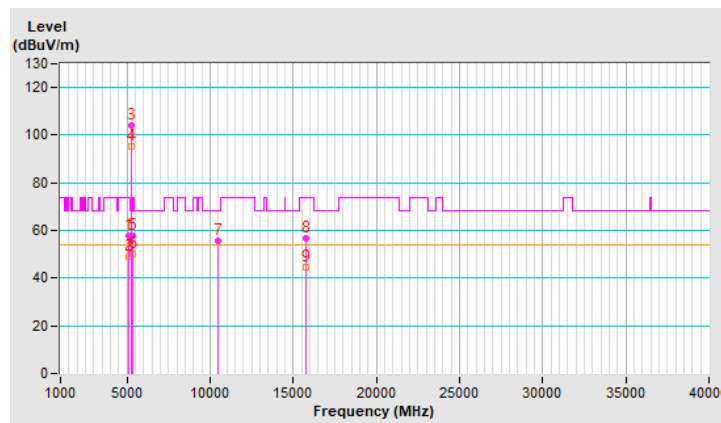

RF Mode	TX 802.11ax (HE160)	Channel	CH 50 : 5250 MHz
Frequency Range	1 GHz ~ 40 GHz	Detector Function & Bandwidth	(PK) RB = 1 MHz, VB = 3 MHz (AV) RB = 1 MHz, VB = 10 Hz
Input Power	120 Vac, 60 Hz	Environmental Conditions	20°C, 70% RH
Tested By	Ryan Du		

Antenna Polarity & Test Distance : Vertical at 3 m								
No	Frequency (MHz)	Emission Level (dBuV/m)	Limit (dBuV/m)	Margin (dB)	Antenna Height (m)	Table Angle (Degree)	Raw Value (dBuV)	Correction Factor (dB/m)
1	5137.37	59.9 PK	74.0	-14.1	1.59 V	113	55.1	4.8
2	5137.37	52.4 AV	54.0	-1.6	1.59 V	113	47.6	4.8
3	*5250.00	107.2 PK			1.59 V	113	102.8	4.4
4	*5250.00	98.2 AV			1.59 V	113	93.8	4.4
5	5367.38	61.5 PK	74.0	-12.5	1.59 V	113	56.9	4.6
6	5367.38	53.3 AV	54.0	-0.7	1.59 V	113	48.7	4.6
7	#10500.00	55.8 PK	68.2	-12.4	1.96 V	317	41.3	14.5
8	15750.00	55.9 PK	74.0	-18.1	1.42 V	84	42.4	13.5
9	15750.00	45.8 AV	54.0	-8.2	1.42 V	84	32.3	13.5

Remarks:

1. Emission Level(dBuV/m) = Raw Value(dBuV) + Correction Factor(dB/m)
2. Correction Factor(dB/m) = Antenna Factor(dB/m) + Cable Factor(dB) – Pre-Amplifier Factor(dB)
3. Margin value = Emission Level – Limit value
4. The other emission levels were very low against the limit.
5. " * " : Fundamental frequency, the limit was restricted at the RF Output Power.
6. " # " : The radiated frequency is out of the restricted band.

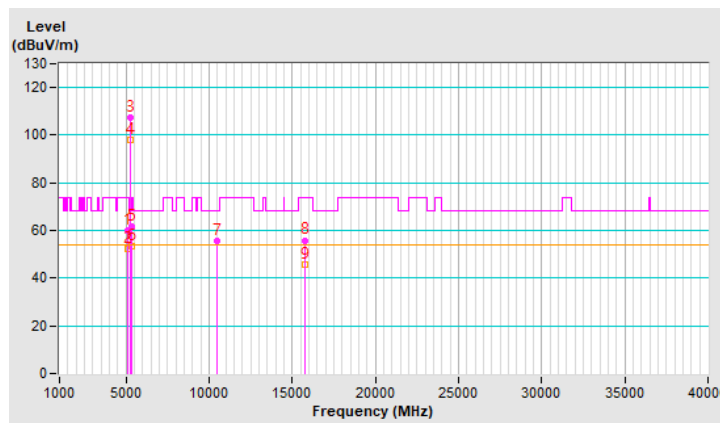

RF Mode	TX 802.11ax (HE160)	Channel	CH 114 : 5570 MHz
Frequency Range	1 GHz ~ 40 GHz	Detector Function & Bandwidth	(PK) RB = 1 MHz, VB = 3 MHz (AV) RB = 1 MHz, VB = 10 Hz
Input Power	120 Vac, 60 Hz	Environmental Conditions	20°C, 70% RH
Tested By	Ryan Du		

Antenna Polarity & Test Distance : Horizontal at 3 m

No	Frequency (MHz)	Emission Level (dBuV/m)	Limit (dBuV/m)	Margin (dB)	Antenna Height (m)	Table Angle (Degree)	Raw Value (dBuV)	Correction Factor (dB/m)
1	5449.16	56.4 PK	74.0	-17.6	2.47 H	79	51.6	4.8
2	5449.16	49.4 AV	54.0	-4.6	2.47 H	79	44.6	4.8
3	#5465.51	56.9 PK	68.2	-11.3	2.47 H	79	52.1	4.8
4	*5570.00	107.0 PK			2.47 H	79	102.2	4.8
5	*5570.00	97.8 AV			2.47 H	79	93.0	4.8
6	11140.00	55.8 PK	74.0	-18.2	1.50 H	269	41.2	14.6
7	11140.00	44.7 AV	54.0	-9.3	1.50 H	269	30.1	14.6
8	#16710.00	55.8 PK	68.2	-12.4	1.60 H	33	39.2	16.6

Remarks:

1. Emission Level(dBuV/m) = Raw Value(dBuV) + Correction Factor(dB/m)
2. Correction Factor(dB/m) = Antenna Factor(dB/m) + Cable Factor(dB) – Pre-Amplifier Factor(dB)
3. Margin value = Emission Level – Limit value
4. The other emission levels were very low against the limit.
5. " * " : Fundamental frequency, the limit was restricted at the RF Output Power.
6. " # " : The radiated frequency is out of the restricted band.

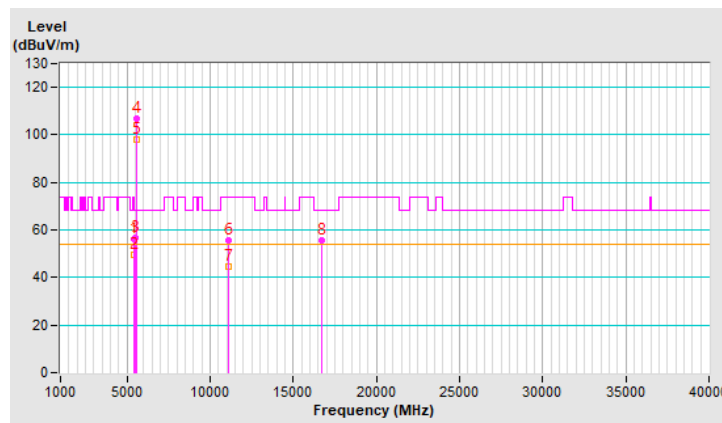

RF Mode	TX 802.11ax (HE160)	Channel	CH 114 : 5570 MHz
Frequency Range	1 GHz ~ 40 GHz	Detector Function & Bandwidth	(PK) RB = 1 MHz, VB = 3 MHz (AV) RB = 1 MHz, VB = 10 Hz
Input Power	120 Vac, 60 Hz	Environmental Conditions	20°C, 70% RH
Tested By	Ryan Du		

Antenna Polarity & Test Distance : Vertical at 3 m								
No	Frequency (MHz)	Emission Level (dBuV/m)	Limit (dBuV/m)	Margin (dB)	Antenna Height (m)	Table Angle (Degree)	Raw Value (dBuV)	Correction Factor (dB/m)
1	5451.30	61.0 PK	74.0	-13.0	1.53 V	286	56.2	4.8
2	5451.30	53.2 AV	54.0	-0.8	1.53 V	286	48.4	4.8
3	#5463.82	62.6 PK	68.2	-5.6	1.53 V	286	57.8	4.8
4	*5570.00	111.0 PK			1.53 V	286	106.2	4.8
5	*5570.00	102.0 AV			1.53 V	286	97.2	4.8
6	11140.00	55.8 PK	74.0	-18.2	2.03 V	317	41.2	14.6
7	11140.00	44.9 AV	54.0	-9.1	2.03 V	317	30.3	14.6
8	#16710.00	56.6 PK	68.2	-11.6	1.32 V	102	40.0	16.6

Remarks:

1. Emission Level(dBuV/m) = Raw Value(dBuV) + Correction Factor(dB/m)
2. Correction Factor(dB/m) = Antenna Factor(dB/m) + Cable Factor(dB) – Pre-Amplifier Factor(dB)
3. Margin value = Emission Level – Limit value
4. The other emission levels were very low against the limit.
5. " * ": Fundamental frequency, the limit was restricted at the RF Output Power.
6. " # ": The radiated frequency is out of the restricted band.

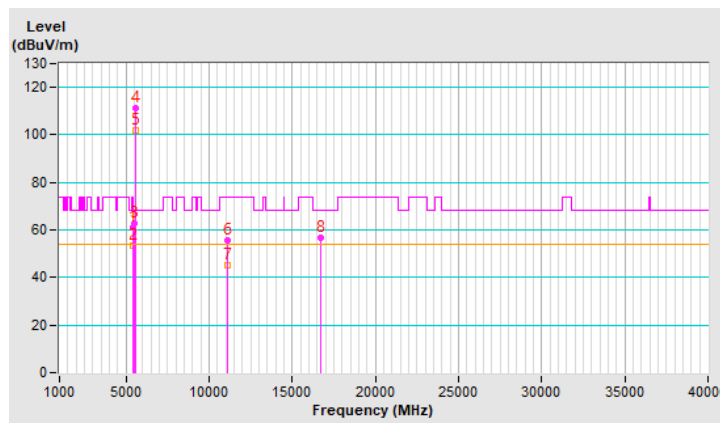

Plot of Band Edge

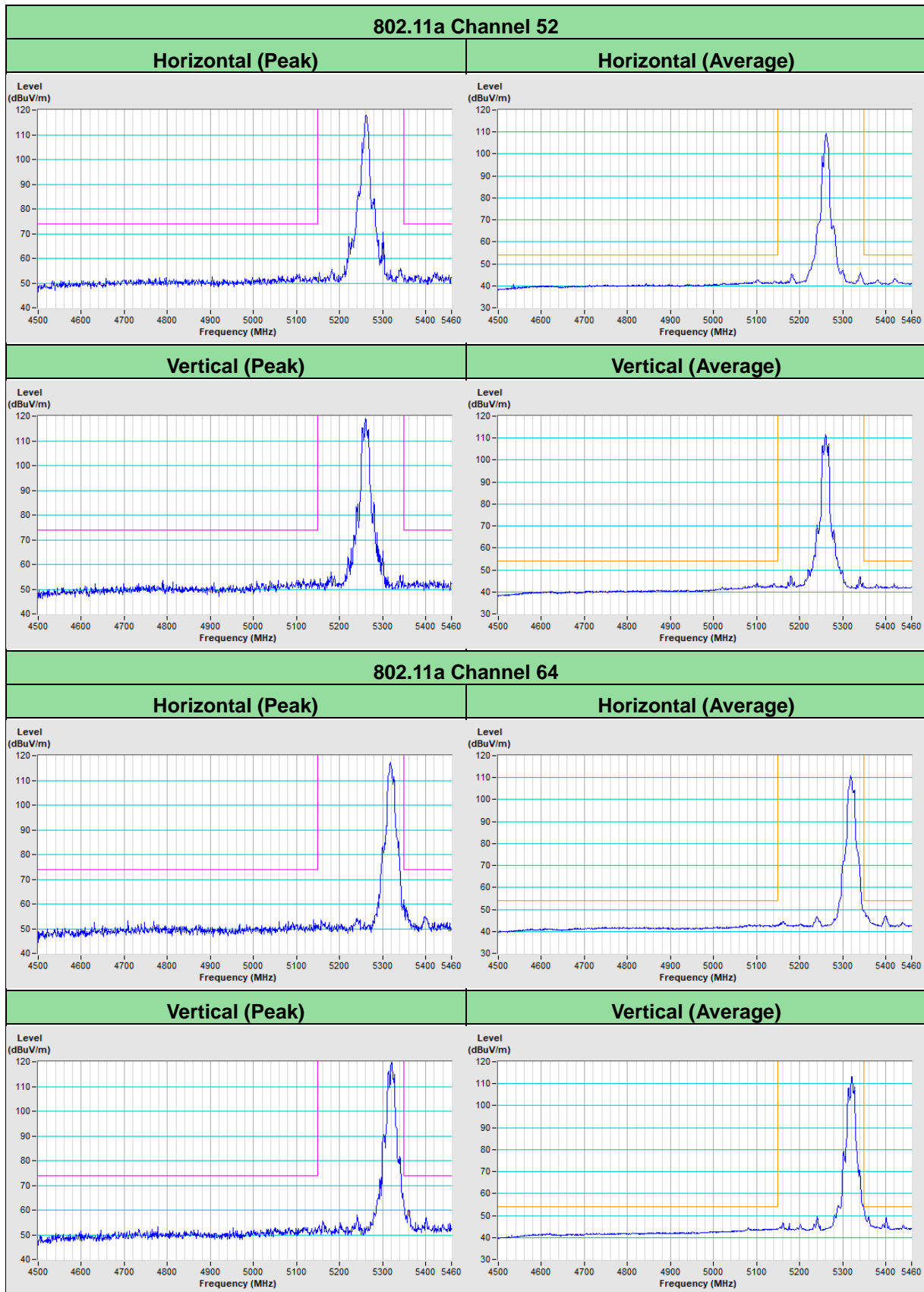

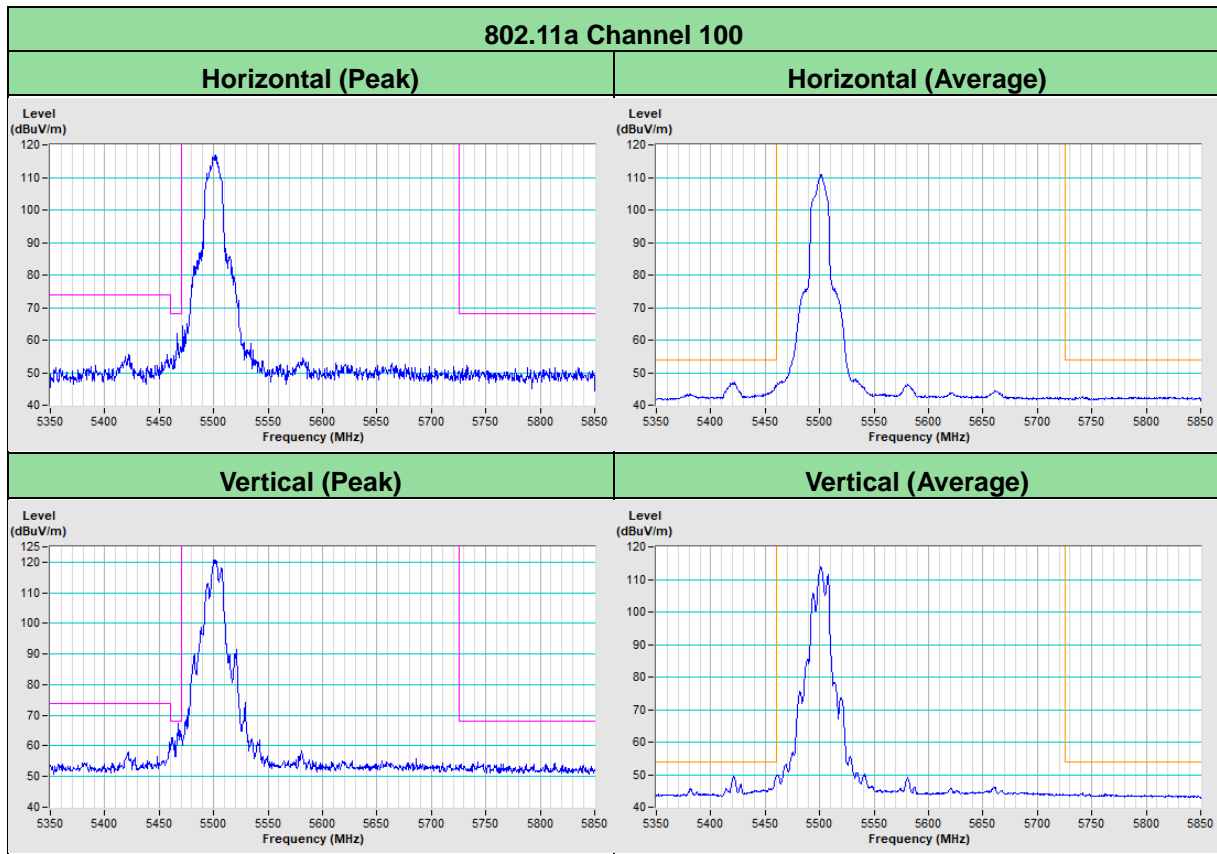

802.11ax (HE20) Channel 52

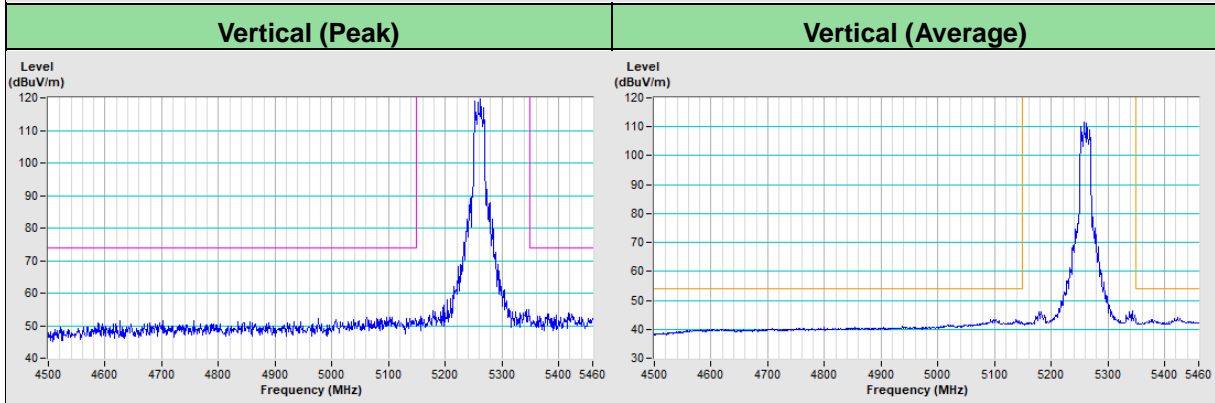
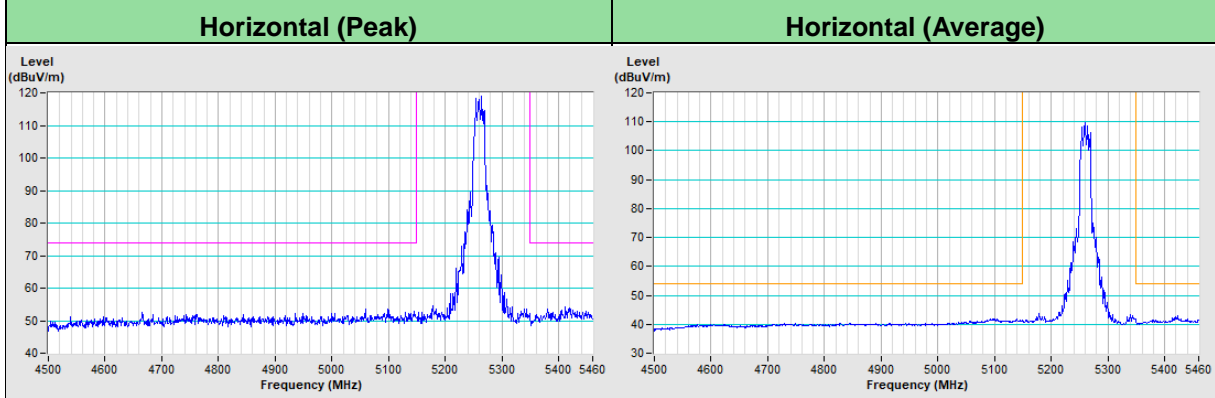

802.11ax (HE20) Channel 64

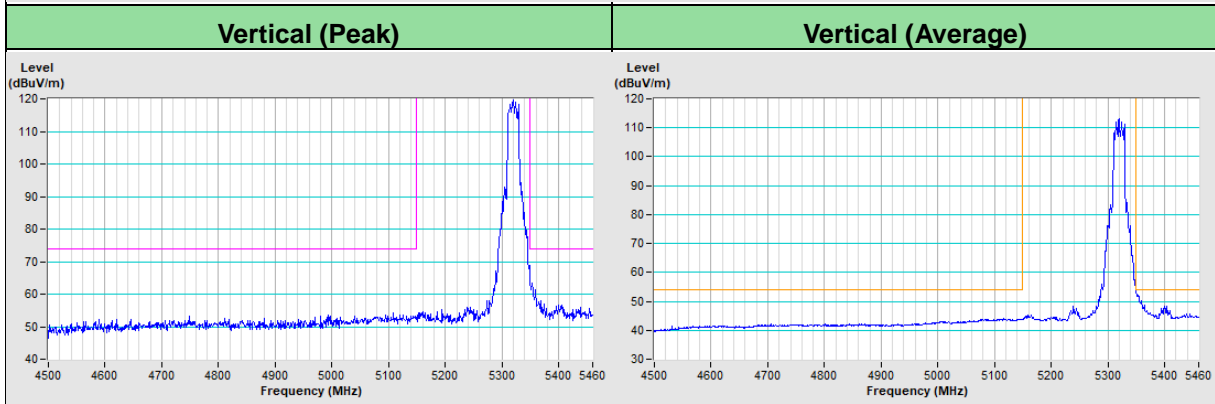
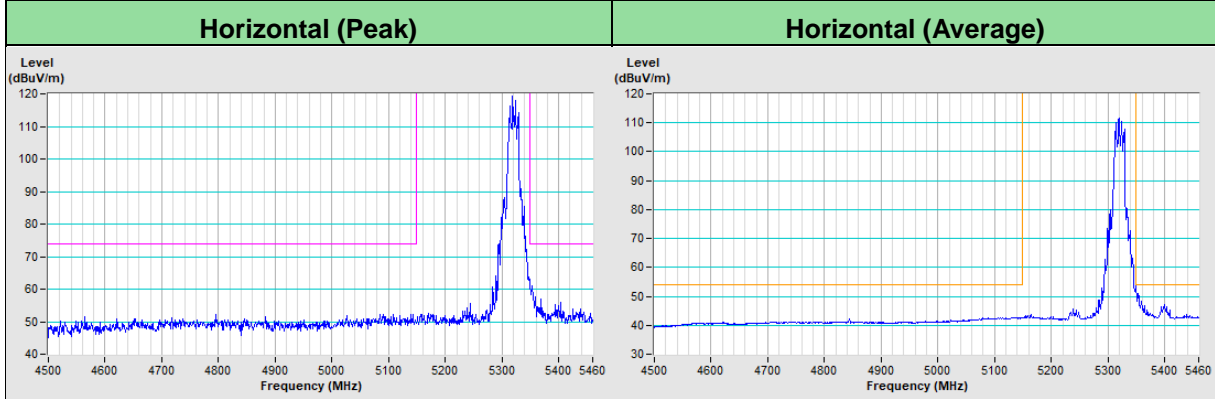

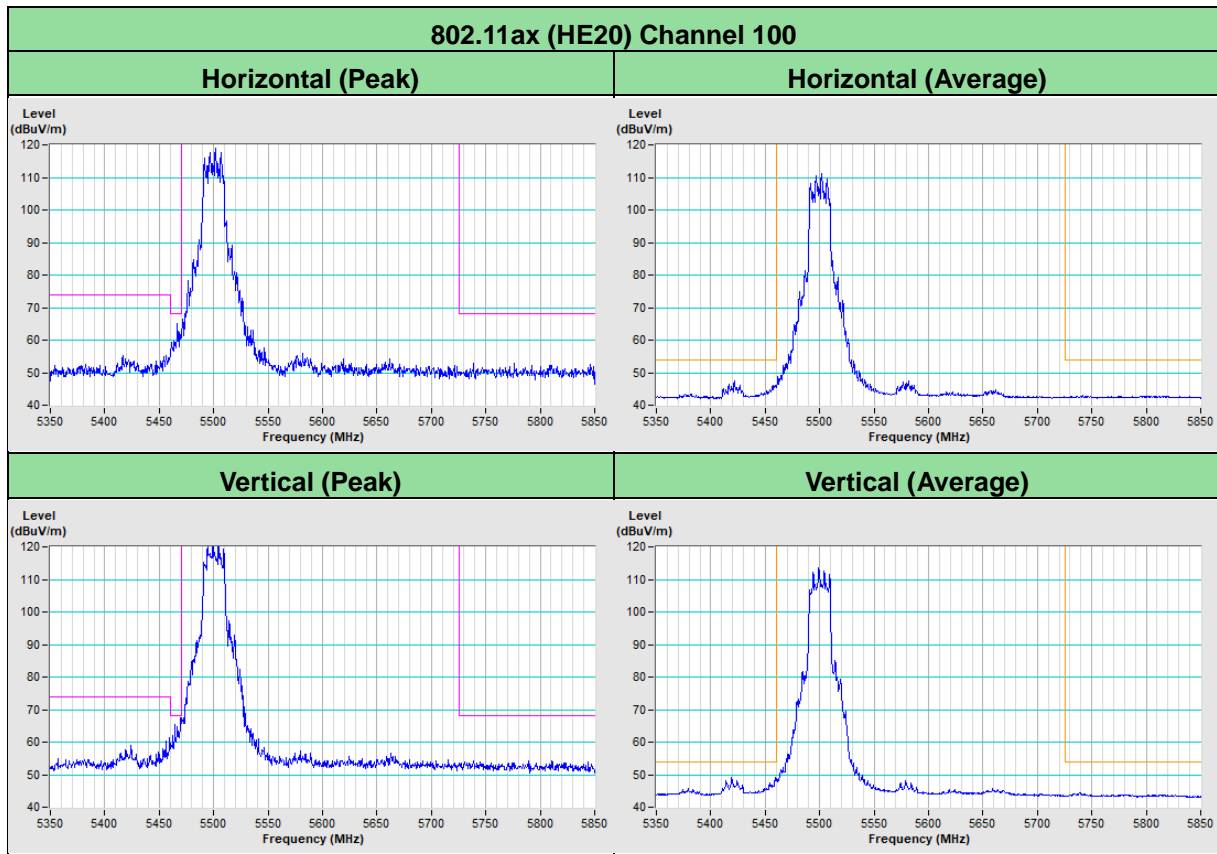

802.11ax (HE40) Channel 54

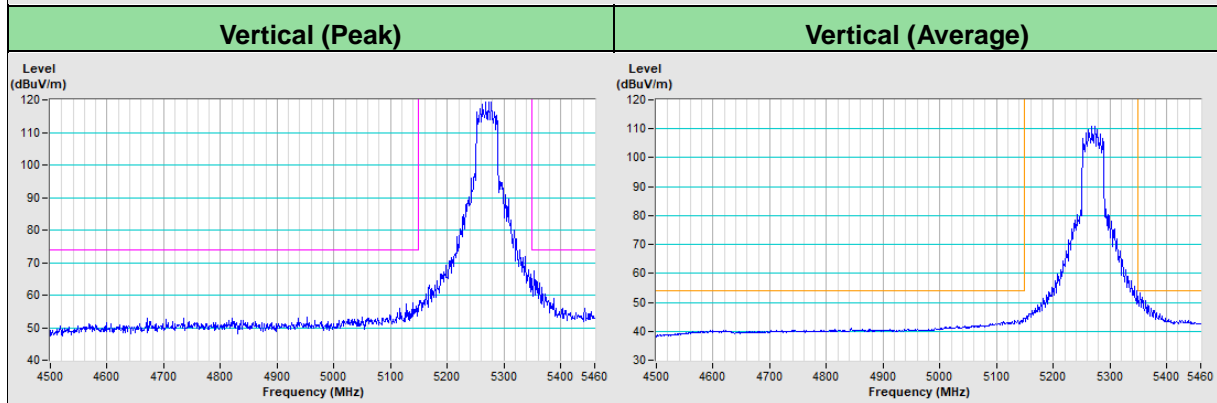
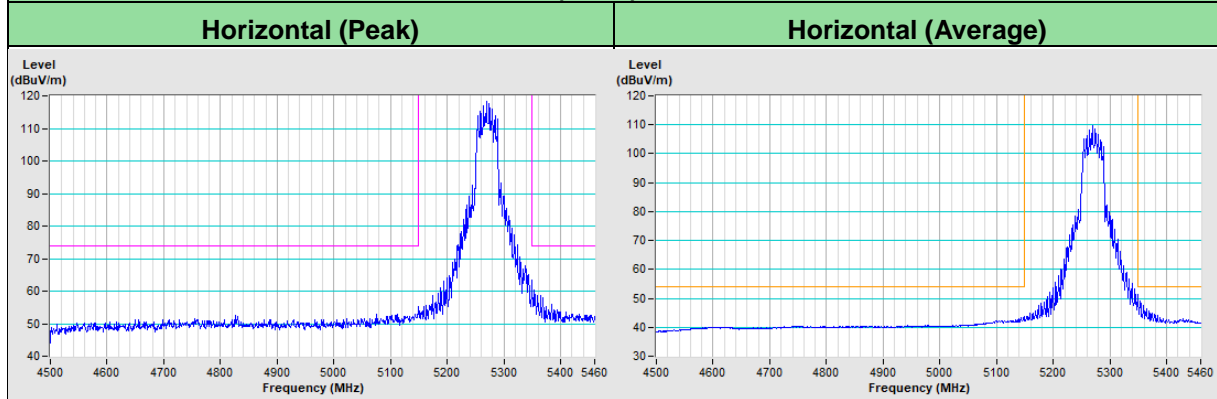

802.11ax (HE40) Channel 62

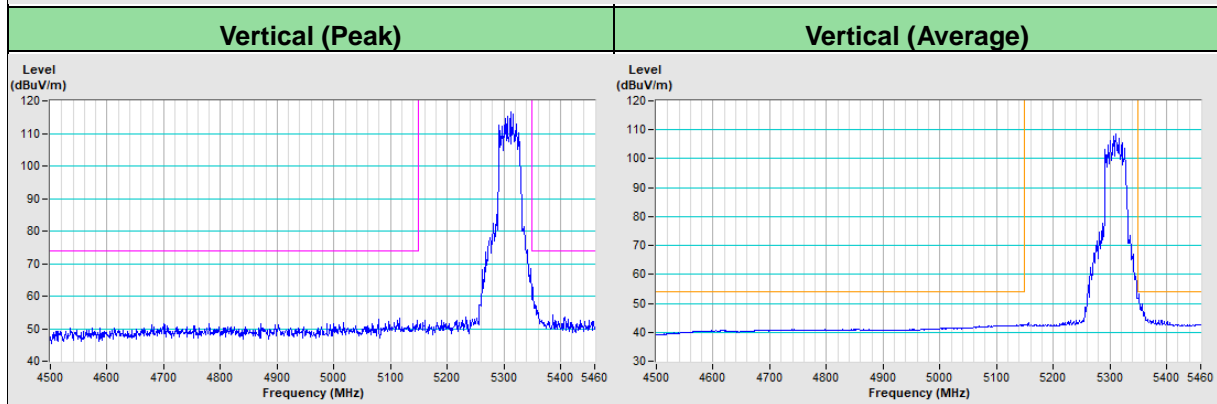
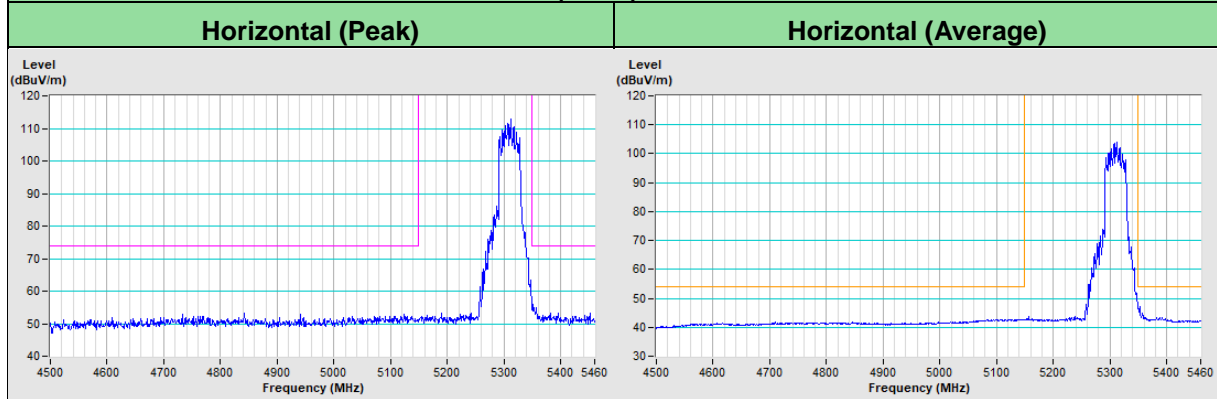

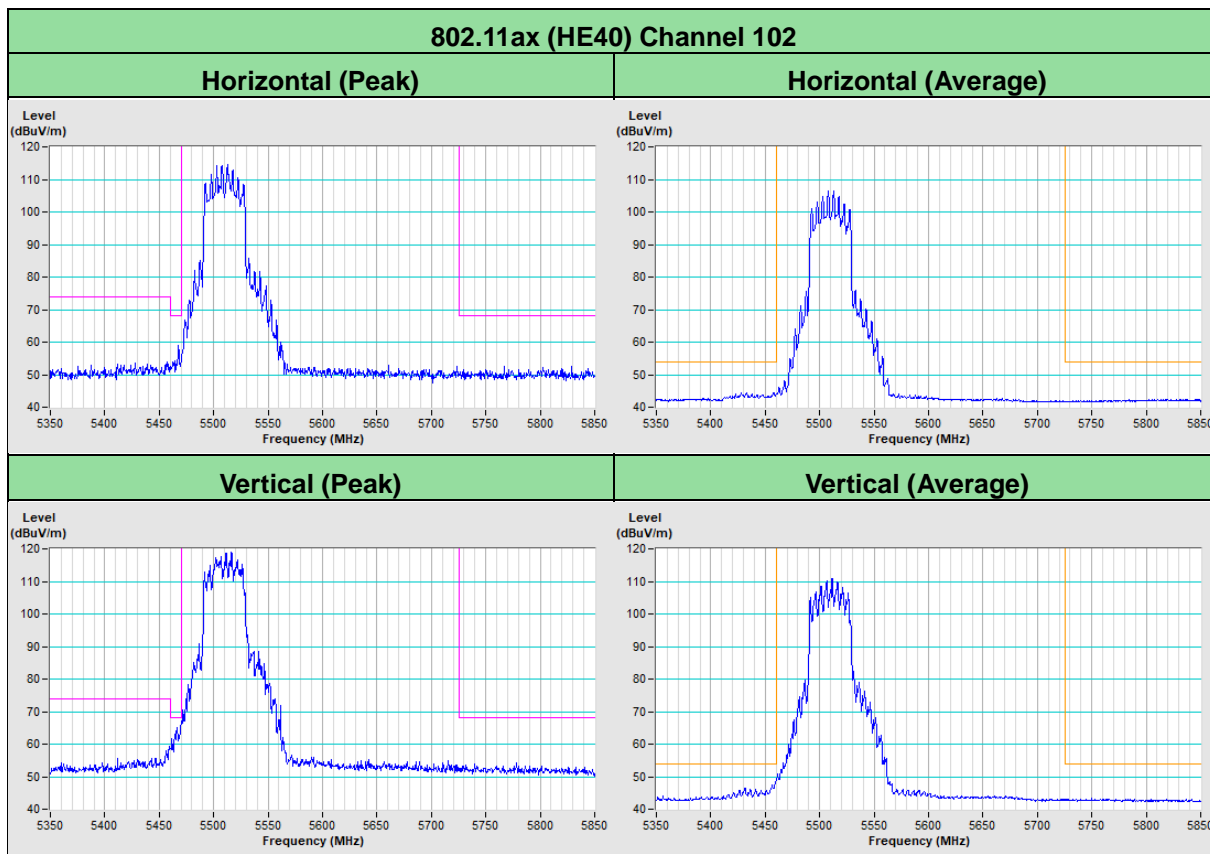

802.11ax (HE80) Channel 58

Horizontal (Peak)

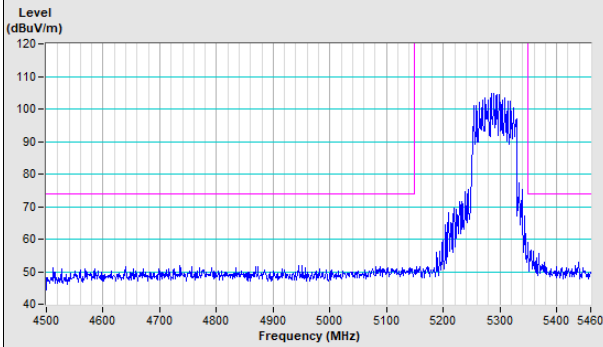

Horizontal (Average)

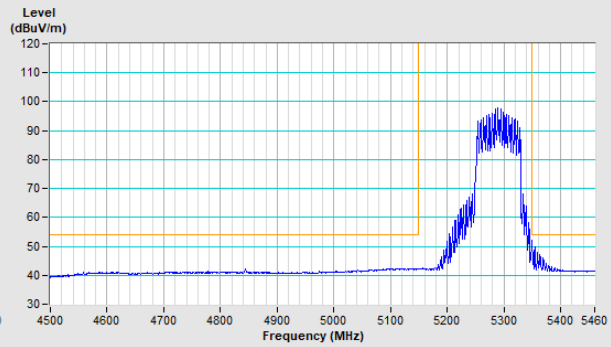

Vertical (Peak)

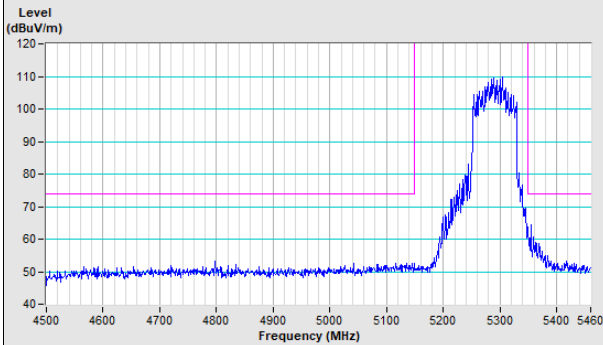

Vertical (Average)

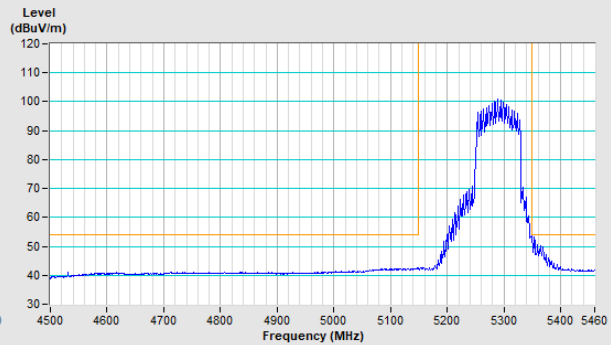

802.11ax (HE80) Channel 106

Horizontal (Peak)

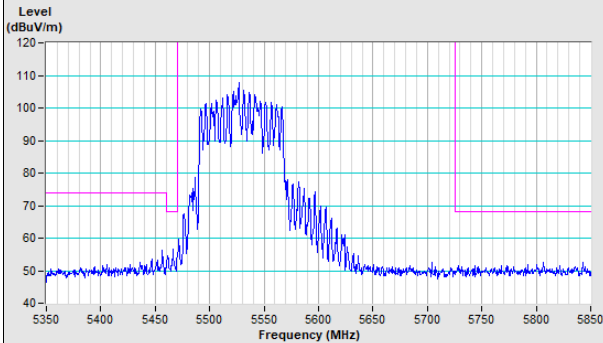

Horizontal (Average)

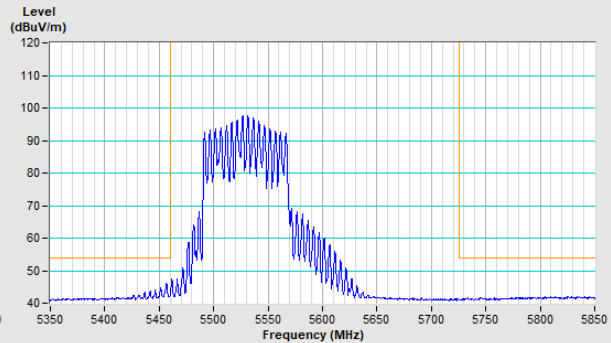

Vertical (Peak)

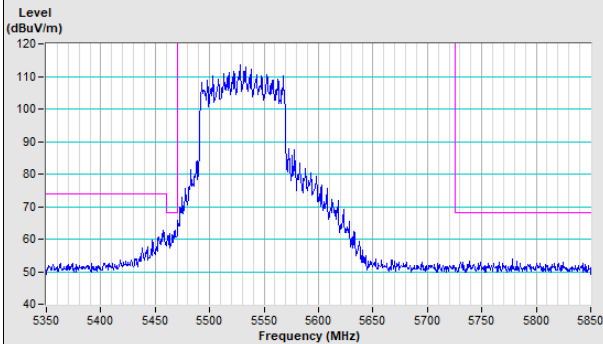

Vertical (Average)

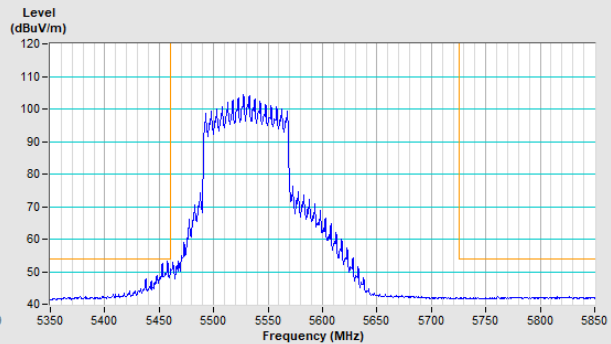

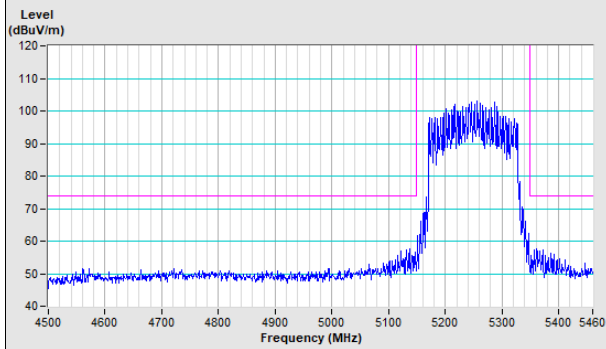
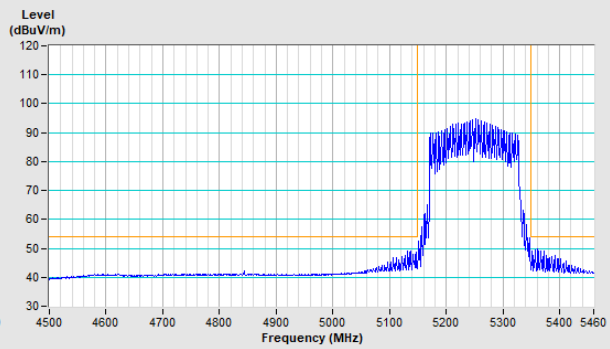
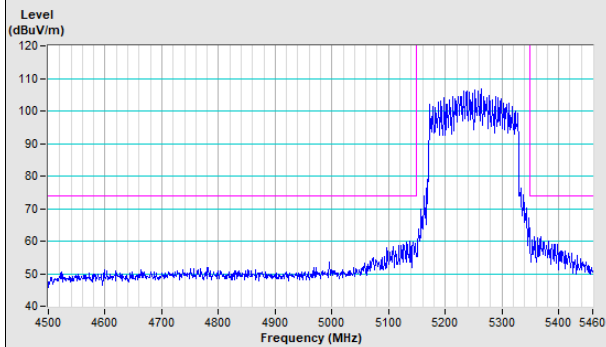
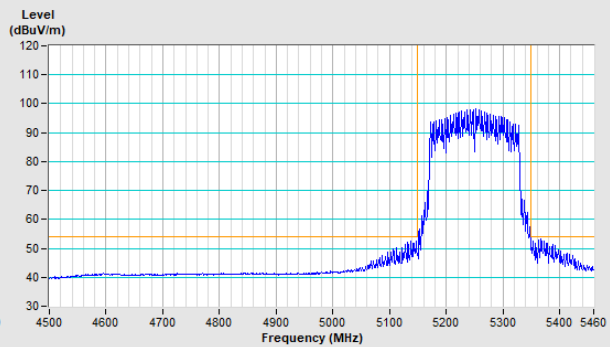
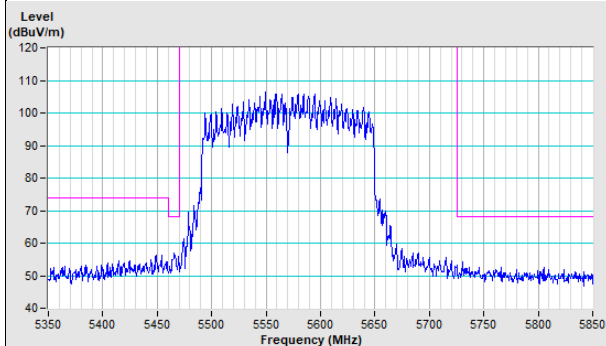
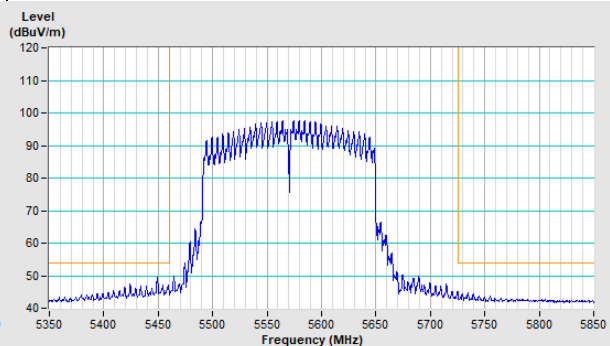
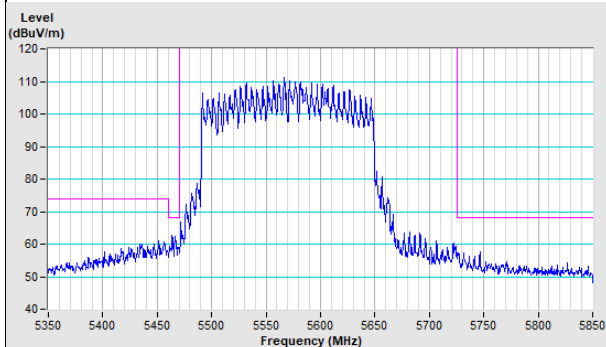
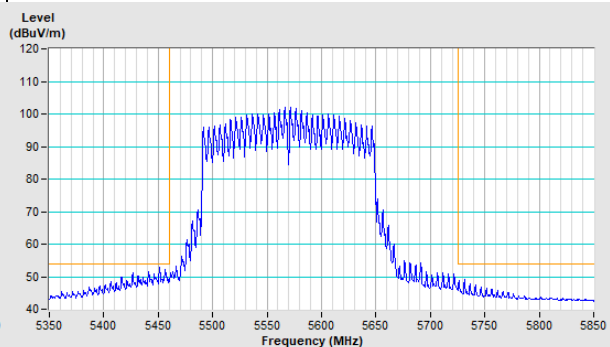
802.11ax (HE160) Channel 50**Horizontal (Peak)****Horizontal (Average)****Vertical (Peak)****Vertical (Average)****802.11ax (HE160) Channel 114****Horizontal (Peak)****Horizontal (Average)****Vertical (Peak)****Vertical (Average)**

8 Pictures of Test Arrangements

Please refer to the attached file (Test Setup Photo)

9 Information of the Testing Laboratories

We, Bureau Veritas Consumer Products Services (H.K.) Ltd., Taoyuan Branch, were founded in 1988 to provide our best service in EMC, Radio, Telecom and Safety consultation. Our laboratories are FCC recognized accredited test firms and accredited according to ISO/IEC 17025.

If you have any comments, please feel free to contact us at the following:

Lin Kou EMC/RF Lab

Tel: 886-2-26052180

Fax: 886-2-26051924

Hsin Chu EMC/RF/Telecom Lab

Tel: 886-3-6668565

Fax: 886-3-6668323

Hwa Ya EMC/RF/Safety Lab

Tel: 886-3-3183232

Fax: 886-3-3270892

Email: service.adt@bureauveritas.com

Web Site: <http://ee.bureauveritas.com.tw>

The address and road map of all our labs can be found in our web site also.

--- END ---