

# FCC Test Report

**FCC ID** : I88EE6601-00  
**Equipment** : Tri-Band Wireless BE19000 10G Ethernet VoIP Gateway with SFP+  
**Model No.** : EE6601-00  
**Multiple Listing** : Refer to item 1.1.1 for more details  
**Brand Name** : ZYXEL  
**Applicant** : Zyxel Communications Corporation  
**Address** : No.2 Industry East RD. IX, Hsinchu Science Park, Hsinchu 30075, Taiwan  
**Standard** : 47 CFR FCC Part 15.407  
**Received Date** : Apr. 08, 2024  
**Tested Date** : Apr. 25 ~ May 15, 2024

We, International Certification Corporation, would like to declare that the tested sample has been evaluated and in compliance with the requirement of the above standards. The test results contained in this report refer exclusively to the product. It shall not be reproduced except in full without the written approval of our laboratory.

Reviewed by:

Approved by:

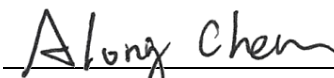
  
\_\_\_\_\_  
Along Chen / Assistant Manager

  
\_\_\_\_\_  
Gary Chang / Manager

---

## Table of Contents

<b>1</b>	<b>GENERAL DESCRIPTION .....</b>	<b>5</b>
1.1	Information.....	5
1.2	Local Support Equipment List .....	13
1.3	Test Setup Chart .....	13
1.4	The Equipment List .....	14
1.5	Test Standards .....	15
1.6	Reference Guidance .....	15
1.7	Deviation from Test Standard and Measurement Procedure.....	15
1.8	Measurement Uncertainty .....	16
<b>2</b>	<b>TEST CONFIGURATION .....</b>	<b>17</b>
2.1	Testing Facility.....	17
2.2	The Worst Test Modes and Channel Details .....	18
<b>3</b>	<b>TRANSMITTER TEST RESULTS.....</b>	<b>20</b>
3.1	Emission Bandwidth .....	20
3.2	Conducted Output Power .....	21
3.3	Power Spectral Density .....	23
3.4	Unwanted Emissions.....	25
3.5	Frequency Stability.....	28
3.6	AC Power Line Conducted Emissions .....	29
<b>4</b>	<b>TEST LABORATORY INFORMATION .....</b>	<b>30</b>
<b>Appendix A. Emission Bandwidth</b>		
<b>Appendix B. Conducted Output Power</b>		
<b>Appendix C. Power Spectral Density</b>		
<b>Appendix D. Unwanted Emissions</b>		
<b>Appendix E. Frequency Stability</b>		
<b>Appendix F. AC Power Line Conducted Emissions</b>		

---

## Release Record

Report No.	Version	Description	Issued Date
FR440801AN	Rev. 01	Initial issue	Jul. 02, 2024

## Summary of Test Results

FCC Rules	Test Items	Measured	Result
15.207	AC Power Line Conducted Emissions	[dBuV]: 0.322MHz 35.08 (Margin -14.58dB) - AV	Pass
15.407(b) 15.209	Unwanted Emissions	[dBuV/m at 3m]: 5725.00MHz 68.09 (Margin -0.11dB) - PK	Pass
15.407(a)	Emission Bandwidth	Meet the requirement of limit	Pass
15.407(e)	6dB bandwidth	Meet the requirement of limit	Pass
15.407(a)	Conducted Output Power	Max Power [dBm]: <b>Non-beamforming mode</b> 5150~5250MHz: 29.68 5250~5350MHz: 23.88 5470~5725MHz: 23.87 5725~5850MHz: 29.88 <b>Beamforming mode</b> 5150~5250MHz: 29.22 5250~5350MHz: 22.68 5470~5725MHz: 22.78 5725~5850MHz: 28.13	Pass
15.407(a)	Power Spectral Density	Meet the requirement of limit	Pass
15.407(g)	Frequency Stability	Meet the requirement of limit	Pass
15.203	Antenna Requirement	Meet the requirement of limit	Pass

### Declaration of Conformity:

The test results with all measurement uncertainty excluded are presented in accordance with the regulation limits or requirements declared by manufacturers.

### Comments and Explanations:

The declared of product specification for EUT presented in the report are provided by the manufacturer, and the manufacturer takes all the responsibilities for the accuracy of product specification.

# 1 General Description

## 1.1 Information

### 1.1.1 Product Details

The following models are provided to this EUT.

Model Name	Product Name	VOIP	SFP+ cage
EE6601-00	Tri-Band Wireless BE19000 10G Ethernet VoIP Gateway with SFP+	V	V
EE6601-01	Tri-Band Wireless BE19000 10G Ethernet VoIP Gateway	V	X
EE6600-00	Tri-Band Wireless BE19000 10G Ethernet Gateway with SFP+	X	V
EE6600-01	Tri-Band Wireless BE19000 10G Ethernet Gateway	X	X

✦ The above models, model **EE6601-00** was selected as a representative one for the final test and only its data was recorded in this report.

### 1.1.2 Specification of the Equipment under Test (EUT)

RF General Information					
Frequency Range (MHz)	IEEE Std. 802.11	Ch. Freq. (MHz)	Channel Number	Transmit Chains (N <sub>TX</sub> )	Data Rate / MCS
5150-5250 5250-5350 5470-5725 5725-5850	a	5180-5240 5260-5320 5500-5720 5745-5825	36-48 [4] 52-64 [4] 100-144 [12] 149-165 [5]	4	6-54 Mbps
5150-5250 5250-5350 5470-5725 5725-5850	n (HT20) ac (VHT20) ax (HE20) be (EHT20)	5180-5240 5260-5320 5500-5720 5745-5825	36-48 [4] 52-64 [4] 100-144 [12] 149-165 [5]	4	MCS 0-31 MCS 0-9 MCS 0-11 MCS 0-13
5150-5250 5250-5350 5470-5725 5725-5850	n (HT40) ac (VHT40) ax (HE40) be (EHT40)	5190-5230 5270-5310 5510-5710 5755-5795	38-46 [2] 54-62 [2] 102-142 [6] 151-159 [2]	4	MCS 0-31 MCS 0-9 MCS 0-11 MCS 0-13
5150-5250 5250-5350 5470-5725 5725-5850	ac (VHT80) ax (HE80) be (EHT80)	5210 5290 5530~5690 5775	42 [1] 58 [1] 106-138 [3] 155 [1]	4	MCS 0-9 MCS 0-11 MCS 0-13
5150-5250 5250-5350 5470-5725	ac (VHT160) ax (HE160) be (EHT160)	5250 5570	50 [1] 114 [1]	4	MCS 0-11 MCS 0-11 MCS 0-13

Note: OFDM/OFDMA-BPSK, QPSK, 16QAM, 64QAM, 256QAM, 1024QAM and 4096QAM modulation.

### 1.1.3 Configuration of Equipment under Test (EUT)

<b>Power Supply Type</b>	12Vdc from adapter	
<b>TPC</b>	<input checked="" type="checkbox"/> Support	<input type="checkbox"/> Not support
<b>Beamforming</b>	<input checked="" type="checkbox"/> Support	<input type="checkbox"/> Not support
<b>RU Configuration</b>	<input checked="" type="checkbox"/> Full RU	<input type="checkbox"/> Partial RU
<b>Channel Puncturing</b>	<input type="checkbox"/> Support	<input checked="" type="checkbox"/> Not support

### 1.1.4 Chip and Firmware Version

<b>CPU</b>	Model: BCM4916
<b>Wi-Fi 2.4GHz Chip</b>	Model: BCM6726
<b>Wi-Fi 5GHz Chip</b>	Model: BCM6726
<b>Wi-Fi 6GHz Chip</b>	Model: BCM67263
<b>FW Version</b>	V5.19(ACKR.0)b4_20240523

### 1.1.5 Accessories

Accessories		
No.	Equipment	Description
1	AC adapter	Brand: FRECOM Model: F42L1-120350SPAU Power Rating: I/P: 100-240Vac, 50/60Hz, 1.4A O/P: 12.0Vdc, 3.5A, 42.0W Power line: 1.5m non-shielded without core
2	RJ45 cable	1.5m non-shielded without core

### 1.1.6 Antenna Details

Ant. No.	Brand	Model	Type	Connector	Operating Frequencies (MHz) / Antenna Gain (dBi)				
					2400~2483.5	5150~5250	5250~5350	5470~5725	5725~5850
DW	Aristotle	56-001-000553Z	Dipole	Micro Coaxial Switch	2.24	3.69	3.42	4.29	3.68
DU1				UFL	2.33	4.17	3.35	4.86	3.58
DY2				UFL	2.21	2.87	2.27	4.18	2.91
DR3				UFL	2.08	4.15	3.46	4.89	4.15

### 1.1.7 Antenna Location

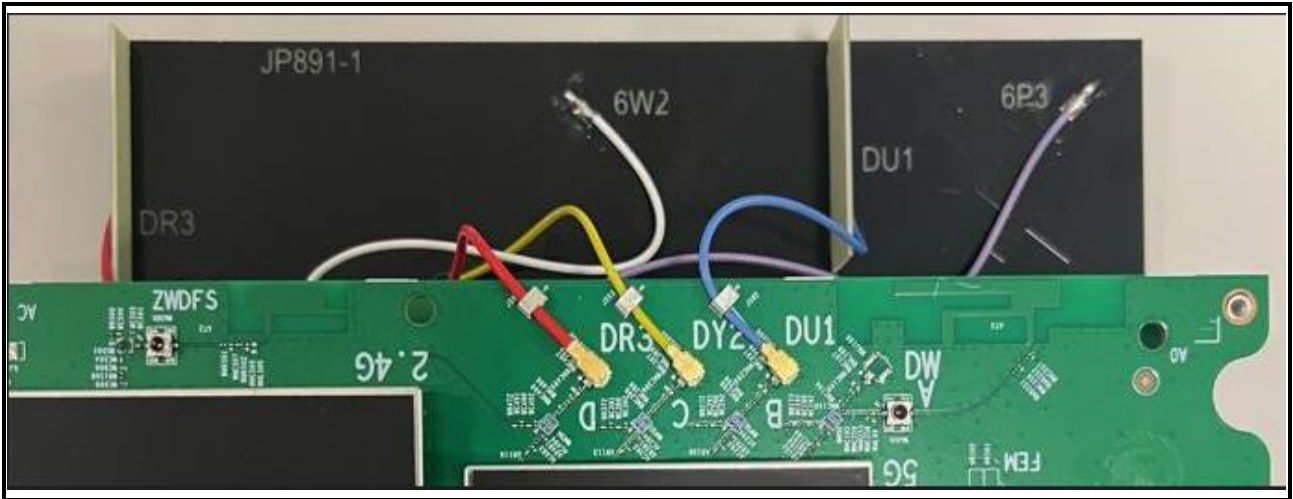

### 1.1.8 Channel List

802.11a / n HT20 / ac VHT20 / ax HE20 / be EHT20		802.11n HT40 / ac VHT40 / ax HE40 / be EHT40	
Channel	Frequency(MHz)	Channel	Frequency(MHz)
36	5180	38	5190
40	5200	46	5230
44	5220	54	5270
48	5240	62	5310
52	5260	102	5510
56	5280	110	5550
60	5300	118	5590
64	5320	126	5630
100	5500	134	5670
104	5520	142	5710
108	5540	151	5755
112	5560	159	5795
116	5580	<b>802.11ac VHT80 / ax HE80 / be EHT80</b>	
120	5600	42	5210
124	5620	58	5290
128	5640	106	5530
132	5660	122	5610
136	5680	138	5690
140	5700	155	5775
144	5720	<b>802.11ac VHT160 / ax HE160 / be EHT160</b>	
149	5745	50	5250
153	5765	114	5570
157	5785	---	---
161	5805	---	---
165	5825	---	---



### 1.1.9 Test Tool and Duty Cycle

Test Tool	accessMtool, V3.3.0.6		
Duty Cycle and Duty Factor	Mode	Duty Cycle (%)	Duty Factor (dB)
	11a	98.28%	0.08
	be EHT20	98.58%	0.06
	be EHT40	98.91%	0.05
	be EHT80	99.24%	0.03
be EHT160	98.99%	0.04	

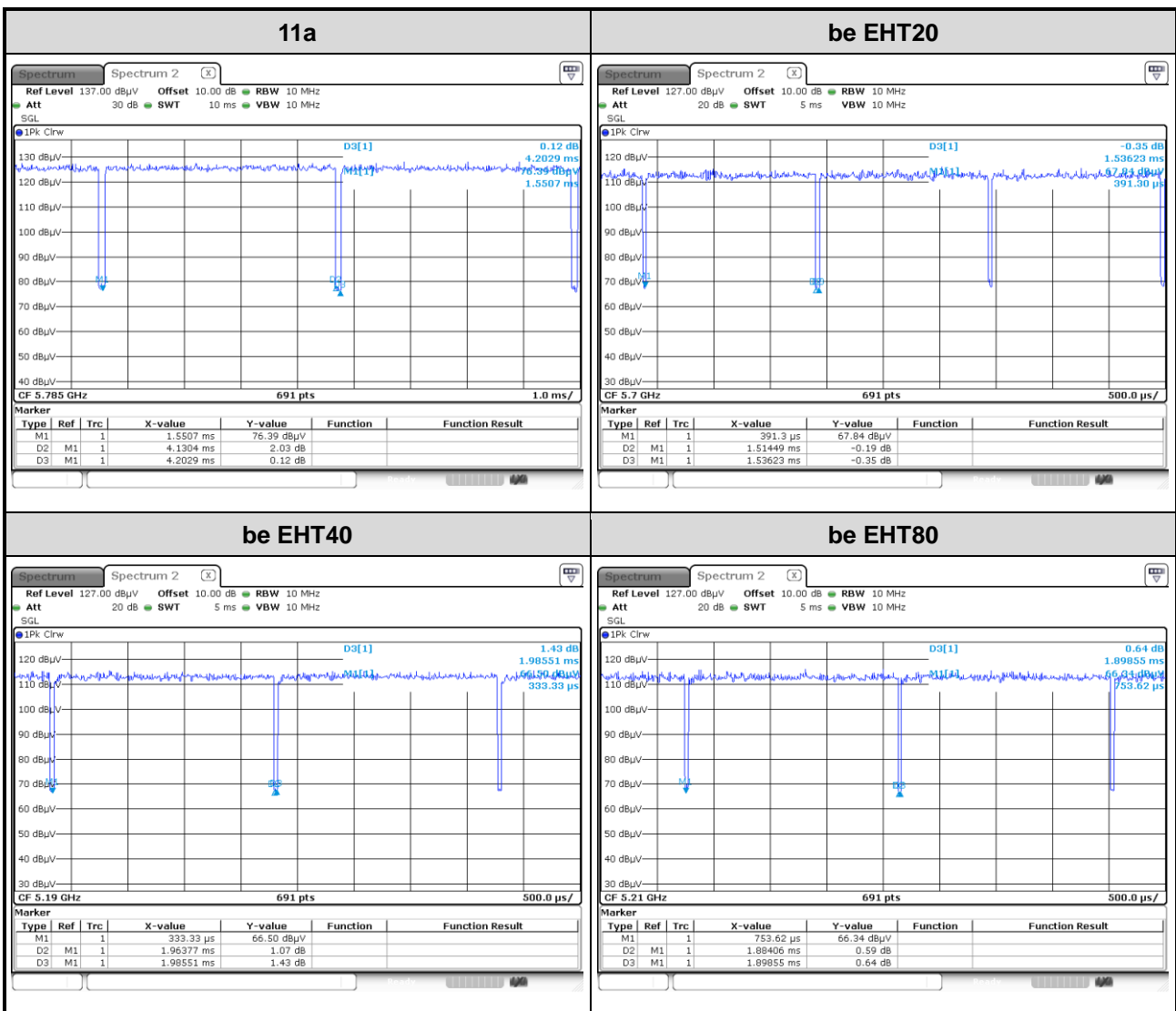

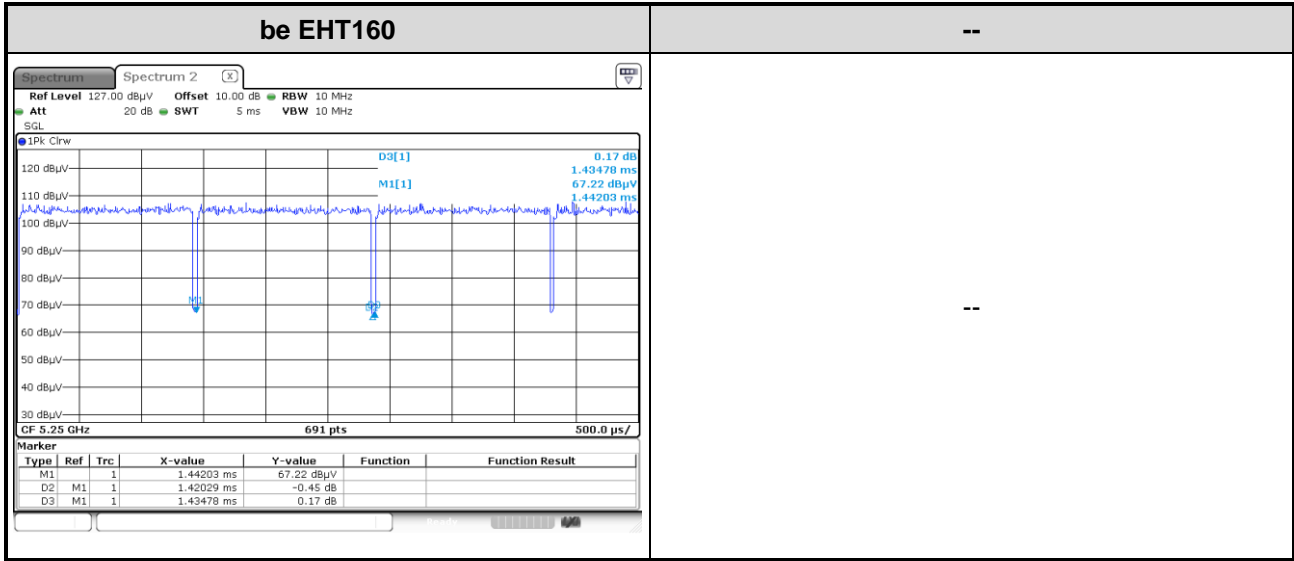

### 1.1.10 Power Index of Test Tool

Modulation Mode	Test Frequency (MHz)	Power Index
11a	5180	78
11a	5200	88
11a	5240	94
11a	5260	64
11a	5300	66
11a	5320	68
11a	5500	70
11a	5580	70
11a	5700	60
11a	5720	66
11a	5745	92
11a	5785	92
11a	5825	92
be EHT20	5180	76
be EHT20	5200	82
be EHT20	5240	94
be EHT20	5260	64
be EHT20	5300	64
be EHT20	5320	68
be EHT20	5500	68
be EHT20	5580	68
be EHT20	5700	54
be EHT20	5720	68
be EHT20	5745	90
be EHT20	5785	92
be EHT20	5825	92
be EHT40	5190	72
be EHT40	5230	80
be EHT40	5270	64
be EHT40	5310	68
be EHT40	5510	68
be EHT40	5590	68
be EHT40	5670	68
be EHT40	5710	70

---

be EHT40	5755	92
be EHT40	5795	92
be EHT80	5210	70
be EHT80	5290	66
be EHT80	5530	68
be EHT80	5610	68
be EHT80	5690	68
be EHT80	5775	82
be EHT160	5250	66
be EHT160	5570	64

## 1.2 Local Support Equipment List

Support Equipment List					
No.	Equipment	Brand	Model	FCC ID	Remarks
1	Laptop	DELL	Latitude 5400	DoC	---
2	Laptop	DELL	Latitude 3440	DoC	---
3	USB 3.0 flash	Transcend	JetFlash 700	---	---
4	Telephone	HTT	HTT-806	---	---
5	Telephone	ISITO	IS-333	---	---
6	RJ45 Load	ICC	---	---	---

## 1.3 Test Setup Chart

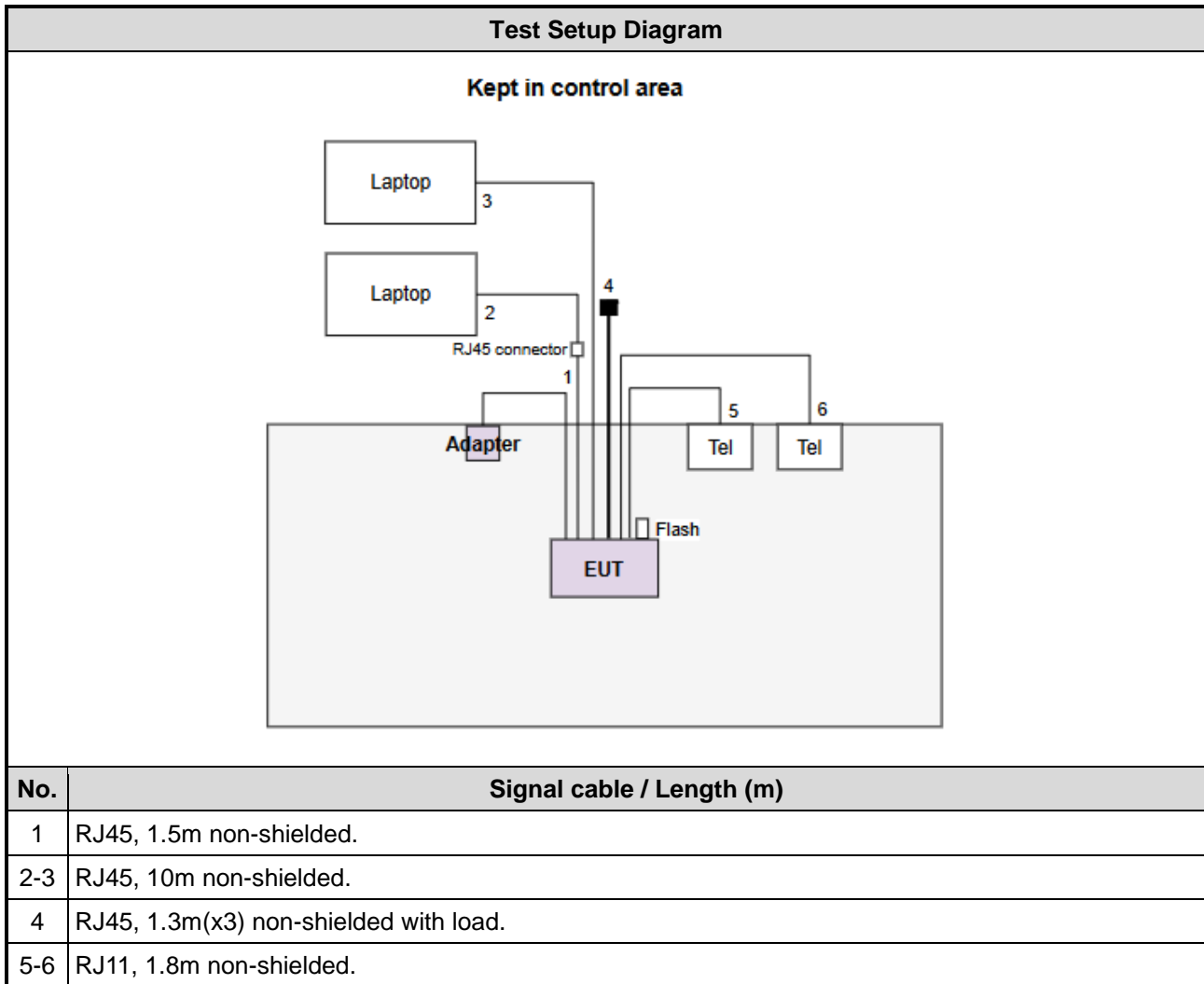

## 1.4 The Equipment List

<b>Test Item</b>	Conducted Emission				
<b>Test Site</b>	Conduction room 1 / (CO01-WS)				
<b>Tested Date</b>	May 06, 2024				
<b>Instrument</b>	<b>Brand</b>	<b>Model No.</b>	<b>Serial No.</b>	<b>Calibration Date</b>	<b>Calibration Until</b>
Receiver	R&S	ESR3	101658	Feb. 23, 2024	Feb. 22, 2025
LISN	R&S	ENV216	101579	May 09, 2023	May 08, 2024
RF Cable-CON	Woken	CFD200-NL	CFD200-NL-001	Oct. 11, 2023	Oct. 10, 2024
LISN (Support Unit)	SCHWARZBECK	Schwarzbeck 8127	8127667	Jan. 10, 2024	Jan. 09, 2025
50 ohm terminal (Support Unit)	NA	50	01	Jun. 14, 2023	Jun. 13, 2024
Measurement Software	AUDIX	e3	6.120210k	NA	NA
Note: Calibration Interval of instruments listed above is one year.					

<b>Test Item</b>	Radiated Emission				
<b>Test Site</b>	966 chamber3 / (03CH03-WS)				
<b>Tested Date</b>	Apr. 25 ~ May 02, 2024				
<b>Instrument</b>	<b>Brand</b>	<b>Model No.</b>	<b>Serial No.</b>	<b>Calibration Date</b>	<b>Calibration Until</b>
Receiver	R&S	ESR3	101657	Mar. 05, 2024	Mar. 04, 2025
Spectrum Analyzer	R&S	FSV40	101499	Apr. 02, 2024	Apr. 01, 2025
Loop Antenna	R&S	HFH2-Z2	100330	Oct. 31, 2023	Oct. 30, 2024
Bilog Antenna	SCHWARZBECK	VULB9168	VULB9168-685	Jul. 04, 2023	Jul. 03, 2024
Horn Antenna 1G-18G	SCHWARZBECK	BBHA 9120 D	BBHA 9120 D 1206	Dec. 14, 2023	Dec. 13, 2024
Horn Antenna 18G-40G	SCHWARZBECK	BBHA 9170	BBHA 9170517	Oct. 30, 2023	Oct. 29, 2024
Preamplifier	EMC	EMC02325	980187	Jul. 10, 2023	Jul. 09, 2024
Preamplifier	EMC	EMC118A45SE	980897	Aug. 01, 2023	Jul. 31, 2024
Preamplifier	EMC	EMC184045SE	980903	Jul. 17, 2023	Jul. 16, 2024
Loop Antenna Cable	KOAX KABEL	101354-BW	101354-BW	Oct. 03, 2023	Oct. 02, 2024
LF cable-0.8M	EMC	EMC8D-NM-NM-800	EMC8D-NM-NM-800-001	Sep. 22, 2023	Sep. 21, 2024
LF cable-3M	EMC	EMC8D-NM-NM-3000	131103	Sep. 22, 2023	Sep. 21, 2024
LF cable-13M	EMC	EMC8D-NM-NM-13000	131104	Sep. 22, 2023	Sep. 21, 2024
RF cable-3M	HUBER+SUHNER	SUCOFLEX104	MY22620/4	Sep. 22, 2023	Sep. 21, 2024
RF cable-8M	EMC	EMC104-SM-SM-8000	181107	Sep. 22, 2023	Sep. 21, 2024
Measurement Software	AUDIX	e3	6.120210g	NA	NA
Attenuator	Pasternack	PE7005-10	10-3	Sep. 27, 2023	Sep. 26, 2024
HIGHPASS FILTER	K&L	11SH10-7000/T1800 0-O/OP	21	Sep. 27, 2023	Sep. 26, 2024
Note: Calibration Interval of instruments listed above is one year.					

<b>Test Item</b>	RF Conducted				
<b>Test Site</b>	(TH01-WS)				
<b>Tested Date</b>	May 02 ~ May 15, 2024				
<b>Instrument</b>	<b>Brand</b>	<b>Model No.</b>	<b>Serial No.</b>	<b>Calibration Date</b>	<b>Calibration Until</b>
Spectrum Analyzer	R&S	FSV40	101910	Apr. 18, 2024	Apr. 17, 2025
Spectrum Analyzer	R&S	FSV3044	101516	Jun. 27, 2023	Jun. 26, 2024
Power Meter	Anritsu	ML2495A	1241002	Nov. 21, 2023	Nov. 20, 2024
Power Sensor	Anritsu	MA2411B	1207366	Nov. 21, 2023	Nov. 20, 2024
Attenuator	Pasternack	PE7005-10	10-2	Oct. 05, 2023	Oct. 04, 2024
TEMP&HUMIDITY CHAMBER	GIANT FORCE	GCT-225-40-SP-SD	MAF1212-002	Jun. 21, 2023	Jun. 20, 2024
AC POWER SOURCE	APC	AFC-500W	F312060012	Dec. 16, 2023	Dec. 15, 2024
Measurement Software	Sporton	SENSE-15407_NII	V5.11	NA	NA
Note: Calibration Interval of instruments listed above is one year.					

## 1.5 Test Standards

47 CFR FCC Part 15.407  
ANSI C63.10-2013

## 1.6 Reference Guidance

FCC KDB 412172 D01 Determining ERP and EIRP v01r01  
FCC KDB 662911 D01 Multiple Transmitter Output v02r01  
FCC KDB 789033 D02 General UNII Test Procedures New Rules v02r01

## 1.7 Deviation from Test Standard and Measurement Procedure

None

## 1.8 Measurement Uncertainty

The measurement uncertainties given below are based on a 95% confidence level (based on a coverage factor (k=2)).

Measurement Uncertainty	
Parameters	Uncertainty
Bandwidth	±34.130 Hz
Conducted power	±0.808 dB
Frequency error	±1×10 <sup>-9</sup>
Power density	±0.583 dB
Conducted emission	±2.715 dB
AC conducted emission	±2.92 dB
Unwanted Emission ≤ 1GHz	±3.96 dB
Unwanted Emission > 1GHz	±4.51 dB
Time	±0.1%
Temperature	±0.4 °C



## 2 Test Configuration

### 2.1 Testing Facility

<b>Test Laboratory</b>	International Certification Corporation
<b>Test Site</b>	CO01-WS, TH01-WS
<b>Address of Test Site</b>	No.3-1, Lane 6, Wen San 3rd St., Kwei Shan Dist., Tao Yuan City 33381, Taiwan (R.O.C.)
<b>Test Site</b>	03CH03-WS
<b>Address of Test Site</b>	No.14-1, Lane 19, Wen San 3rd St., Kwei Shan Dist., Tao Yuan City 33381, Taiwan (R.O.C.)

- FCC Designation No.: TW0009
- FCC site registration No.: 207696
- ISED#: 10807C
- CAB identifier: TW2732

## 2.2 The Worst Test Modes and Channel Details

Frequency band 5150~5350 MHz / 5470~5725 MHz				
Test item	Modulation Mode	Test Frequency (MHz)	Data Rate	Test Configuration
<b>Non-beamforming mode</b>				
AC Power Line Conducted Emissions	be EHT20	5240	MCS 0	---
Unwanted Emissions ≤1GHz	be EHT20	5240	MCS 0	---
Unwanted Emissions >1GHz Conducted Output Power Emission Bandwidth Power Spectral Density	11a	5180 / 5200 / 5240 / 5260 / 5300 5320 / 5500 / 5580 / 5700 / 5720	6 Mbps	---
	be EHT20	5180 / 5200 / 5240 / 5260 / 5300 5320 / 5500 / 5580 / 5700 / 5720	MCS 0	
	be EHT40	5190 / 5230 / 5270 / 5310 / 5510 5590 / 5670 / 5710	MCS 0	
	be EHT80	5210 / 5290 / 5530 / 5610 / 5690	MCS 0	
	be EHT160	5250 / 5570	MCS 0	
Frequency Stability	Un-modulation	5320	---	---
<b>Beamforming mode</b>				
Conducted Output Power	be EHT20	5180 / 5200 / 5240 / 5260 / 5300 5320 / 5500 / 5580 / 5700 / 5720	MCS 0	---
	be EHT40	5190 / 5230 / 5270 / 5310 / 5510 5590 / 5670 / 5710	MCS 0	---
	be EHT80	5210 / 5290 / 5530 / 5610 / 5690	MCS 0	---
	be EHT160	5250 / 5570	MCS 0	---
<b>NOTE:</b>				
1. The EUT was pretested with 3 orientations placed on the table for the radiated emission measurement – X, Y, and Z-plane. The <b>Z-plane</b> results were found as the worst case and were shown in this report.				
2. Beamforming mode is calculated not measured. The calculation method is conducted power of non-beamforming – (Directional gain - max gain of single antenna).				

Frequency band 5725-5850 MHz				
Test item	Modulation Mode	Test Frequency (MHz)	Data Rate	Test Configuration
<b>Non-beamforming mode</b>				
AC Power Line Conducted Emissions	be EHT20	5825	MCS 0	---
Unwanted Emissions ≤1GHz	be EHT20	5825	MCS 0	---
Unwanted Emissions >1GHz Conducted Output Power Emission Bandwidth 6dB bandwidth Power Spectral Density	11a	5745 / 5785 / 5825	6 Mbps	---
	be EHT20	5745 / 5785 / 5825	MCS 0	
	be EHT40	5755 / 5795	MCS 0	
	be EHT80	5775	MCS 0	
Frequency Stability	Un-modulation	5785	---	---
<b>Beamforming mode</b>				
Conducted Output Power	be EHT20	5745 / 5785 / 5825	MCS 0	---
	be EHT40	5755 / 5795	MCS 0	---
	be EHT80	5775	MCS 0	---
<b>NOTE:</b>				
1. The EUT was pretested with 3 orientations placed on the table for the radiated emission measurement – X, Y, and Z-plane. The <b>Z-plane</b> results were found as the worst case and were shown in this report.				
2. Beamforming mode is calculated not measured. The calculation method is conducted power of non-beamforming – (Directional gain - max gain of single antenna).				

### 3 Transmitter Test Results

#### 3.1 Emission Bandwidth

##### 3.1.1 Limit of Emission Bandwidth

Within the 5.725-5.85 GHz band, the minimum 6 dB bandwidth of U-NII devices shall be at least 500 kHz.

##### 3.1.2 Test Procedures

###### 26dB Bandwidth

1. Set RBW = approximately 1% of the emission bandwidth.
2. Set the VBW > RBW, Detector = Peak.
3. Trace mode = max hold.
4. Measure the maximum width of the emission that is 26 dB down from the peak of the emission.

###### Occupied Bandwidth

1. Set RBW = 1 % to 5 % of the OBW.
2. Set VBW  $\geq$  3 RBW.
3. Sample detection and single sweep mode shall be used.
4. Use the 99 % power bandwidth function of the instrument.

###### 6dB Bandwidth

1. Set RBW = 100kHz, VBW = 300kHz.
2. Detector = Peak, Trace mode = max hold.
3. Allow the trace to stabilize.
4. Measure the maximum width of the emission that is constrained by the frequencies associated with the two outermost amplitude points (upper and lower frequencies) that are attenuated by 6 dB relative to the maximum level measured in the fundamental emission.

##### 3.1.3 Test Setup

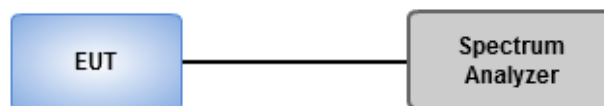

##### 3.1.4 Test Results

<b>Ambient Condition</b>	24-25°C / 64-66%	<b>Tested By</b>	Akun Chung
--------------------------	------------------	------------------	------------

Refer to Appendix A.

## 3.2 Conducted Output Power

### 3.2.1 Limit of Conducted Output Power

Frequency band 5150-5250 MHz	
Operating Mode	Limit
<input type="checkbox"/> Outdoor access point	Conducted Power: 1 W The maximum e.i.r.p. at any elevation angle above 30 degrees as measured from the horizon must not exceed 125 mW (21 dBm)
<input checked="" type="checkbox"/> Indoor access point	Conducted Power: 1 W
<input type="checkbox"/> Fixed point-to-point access points	Conducted Power: 1 W
<input type="checkbox"/> Client devices	Conducted Power: 250 mW

Frequency Band (MHz)	Limit
<input checked="" type="checkbox"/> 5250 ~ 5350	Conducted Power: 250mW or 11dBm+10 log B
<input checked="" type="checkbox"/> 5470 ~ 5725	Conducted Power: 250mW or 11dBm+10 log B
<input checked="" type="checkbox"/> 5725 ~ 5850	Conducted Power: 1 W

Note: "B" is the 26dB emission bandwidth in MHz.

### 3.2.2 Test Procedures

#### Method PM-G (Measurement using a gated RF average power meter)

Measurements is performed using a wideband gated RF power meter provided that the gate parameters are adjusted such that the power is measured only when the EUT is transmitting at its maximum power control level. Since the measurement is made only during the ON time of the transmitter, no duty cycle correction factor is required.

#### Spectrum analyzer (For channel that extends across the 5.725 GHz boundary)

1. Set RBW = 1MHz, VBW = 3MHz, Sweep time = Auto, Detector = RMS.
2. Trace average at least 100 traces in power averaging mode.
3. Compute power by integrating the spectrum across the 26 dB EBW.
4. Add  $10 \log(1/X)$ , X:duty cycle) if duty cycle is <98%).

### 3.2.3 Test Setup

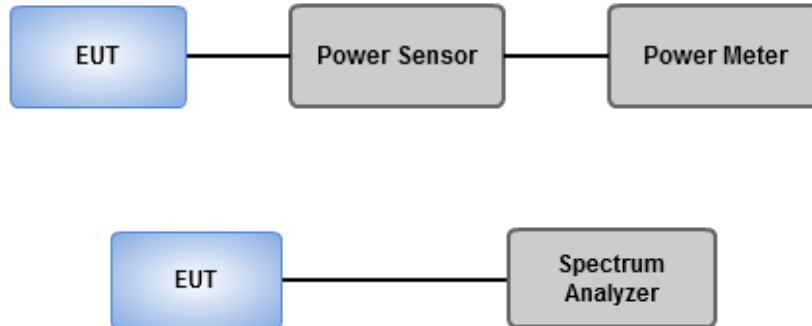

### 3.2.4 Test Results

<b>Ambient Condition</b>	24-25°C / 64-66%	<b>Tested By</b>	Akun Chung
--------------------------	------------------	------------------	------------

Refer to Appendix B.

### 3.3 Power Spectral Density

#### 3.3.1 Limit of Power Spectral Density

Frequency band 5150-5250 MHz		
Operating Mode		Limit
<input type="checkbox"/>	Outdoor access point	17 dBm / MHz
<input checked="" type="checkbox"/>	Indoor access point	17 dBm / MHz
<input type="checkbox"/>	Fixed point-to-point access points	17 dBm / MHz
<input type="checkbox"/>	Client devices	11 dBm / MHz

Frequency Band (MHz)		Limit
<input checked="" type="checkbox"/>	5250 ~ 5350	11 dBm / MHz
<input checked="" type="checkbox"/>	5470 ~ 5725	11 dBm / MHz
<input checked="" type="checkbox"/>	5725 ~ 5850	30 dBm /500 kHz

### 3.3.2 Test Procedures

#### For 5150 ~ 5250 MHz / 5250 ~ 5350 MHz / 5470 ~ 5725 MHz

Duty cycle  $\geq$  98 %

1. Set RBW = 1 MHz, VBW = 3 MHz, Sweep time = auto, Detector = RMS.
2. Trace average 100 traces.
3. Use the peak marker function to determine the maximum amplitude level.

Duty cycle < 98 %

1. Set RBW = 1 MHz, VBW = 3 MHz, Detector = RMS.
2. Set sweep time  $\geq 10 * (\text{number of points in sweep}) * (\text{total on/off period of the transmitted signal})$ .
3. Perform a single sweep.
4. Use the peak marker function to determine the maximum amplitude level.
5. Add  $10 \log(1/x)$ , where x is the duty cycle.

#### For 5725 ~ 5850 MHz

Duty cycle  $\geq$  98 %

1. Set RBW = 500 kHz, VBW = 3 MHz, Sweep time = auto, Detector = RMS.
2. Trace average 100 traces.
3. Use the peak marker function to determine the maximum amplitude level.

Duty cycle < 98 %

1. Set RBW = 500 kHz, VBW = 3 MHz, Detector = RMS.
2. Set sweep time  $\geq 10 * (\text{number of points in sweep}) * (\text{total on/off period of the transmitted signal})$ .
3. Perform a single sweep.
4. Use the peak marker function to determine the maximum amplitude level.
5. Add  $10 \log(1/x)$ , where x is the duty cycle.

### 3.3.3 Test Setup

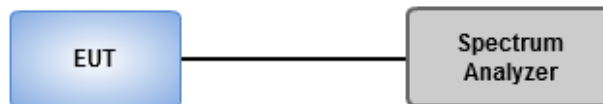

### 3.3.4 Test Results

<b>Ambient Condition</b>	24-25°C / 64-66%	<b>Tested By</b>	Akun Chung
--------------------------	------------------	------------------	------------

Refer to Appendix C.



### 3.4 Unwanted Emissions

#### 3.4.1 Limit of Unwanted Emissions

Restricted Band Emissions Limit			
Frequency Range (MHz)	Field Strength (uV/m)	Field Strength (dBuV/m)	Measure Distance (m)
0.009~0.490	2400/F(kHz)	48.5 - 13.8	300
0.490~1.705	24000/F(kHz)	33.8 - 23	30
1.705~30.0	30	29	30
30~88	100	40	3
88~216	150	43.5	3
216~960	200	46	3
Above 960	500	54	3

**Note 1:**  
Qusai-Peak value is measured for frequency below 1GHz except for 9–90 kHz, 110–490 kHz frequency band. Peak and average value are measured for frequency above 1GHz. The limit on average radio frequency emission is as above table. The limit on peak radio frequency emissions is 20 dB above the maximum permitted average emission limit

**Note 2:**  
Measurements may be performed at a distance other than what is specified provided. When performing measurements at a distance other than that specified, the results shall be extrapolated to the specified distance using an extrapolation factor as below, Frequency at or above 30 MHz: 20 dB/decade Frequency below 30 MHz: 40 dB/decade.

Un-restricted band emissions above 1GHz Limit	
Operating Band	Limit
5.15 - 5.25 GHz	e.i.r.p. -27 dBm [68.2 dBuV/m@3m]
5.25 - 5.35 GHz	e.i.r.p. -27 dBm [68.2 dBuV/m@3m]
5.47 - 5.725 GHz	e.i.r.p. -27 dBm [68.2 dBuV/m@3m]
5.725 - 5.850 GHz	All emissions shall be limited to a level of -27 dBm/MHz at 75 MHz or more above or below the band edge increasing linearly to 10 dBm/MHz at 25 MHz above or below the band edge, and from 25 MHz above or below the band edge increasing linearly to a level of 15.6 dBm/MHz at 5 MHz above or below the band edge, and from 5 MHz above or below the band edge increasing linearly to a level of 27 dBm/MHz at the band edge.

Note 1: Measurements may be performed at a distance other than the limit distance provided they are not performed in the near field and the emissions to be measured can be detected by the measurement equipment. When performing measurements at a distance other than that specified, the results shall be extrapolated to the specified distance using an extrapolation factor of 20 dB/decade (inverse of linear distance for field-strength measurements, inverse of linear distance-squared for power-density measurements).

### 3.4.2 Test Procedures

1. Measurement is made at a semi-anechoic chamber that incorporates a turntable allowing a EUT rotation of 360°. A continuously-rotating, remotely-controlled turntable is installed at the test site to support the EUT and facilitate determination of the direction of maximum radiation for each EUT emission frequency. The EUT is placed at test table. For emissions testing at or below 1 GHz, the table height is 80 cm above the reference ground plane. For emission measurements above 1 GHz, the table height is 1.5 m
2. Measurement is made with the antenna positioned in both the horizontal and vertical planes of polarization. The measurement antenna is varied in height (1m ~ 4m) above the reference ground plane to obtain the maximum signal strength. Distance between EUT and antenna is 3 m.
3. This investigation is performed with the EUT rotated 360°, the antenna height scanned between 1 m and 4 m, and the antenna rotated to repeat the measurements for both the horizontal and vertical antenna polarizations.

Note:

1. 120kHz measurement bandwidth of test receiver and Quasi-peak detector is for radiated emission below 1GHz.
2. RBW=1MHz, VBW=3MHz and Peak detector is for peak measured value of radiated emission above 1GHz.
3. RBW=1MHz, VBW=1/T and Peak detector is for average measured value of radiated emission above 1GHz.

### 3.4.3 Test Setup

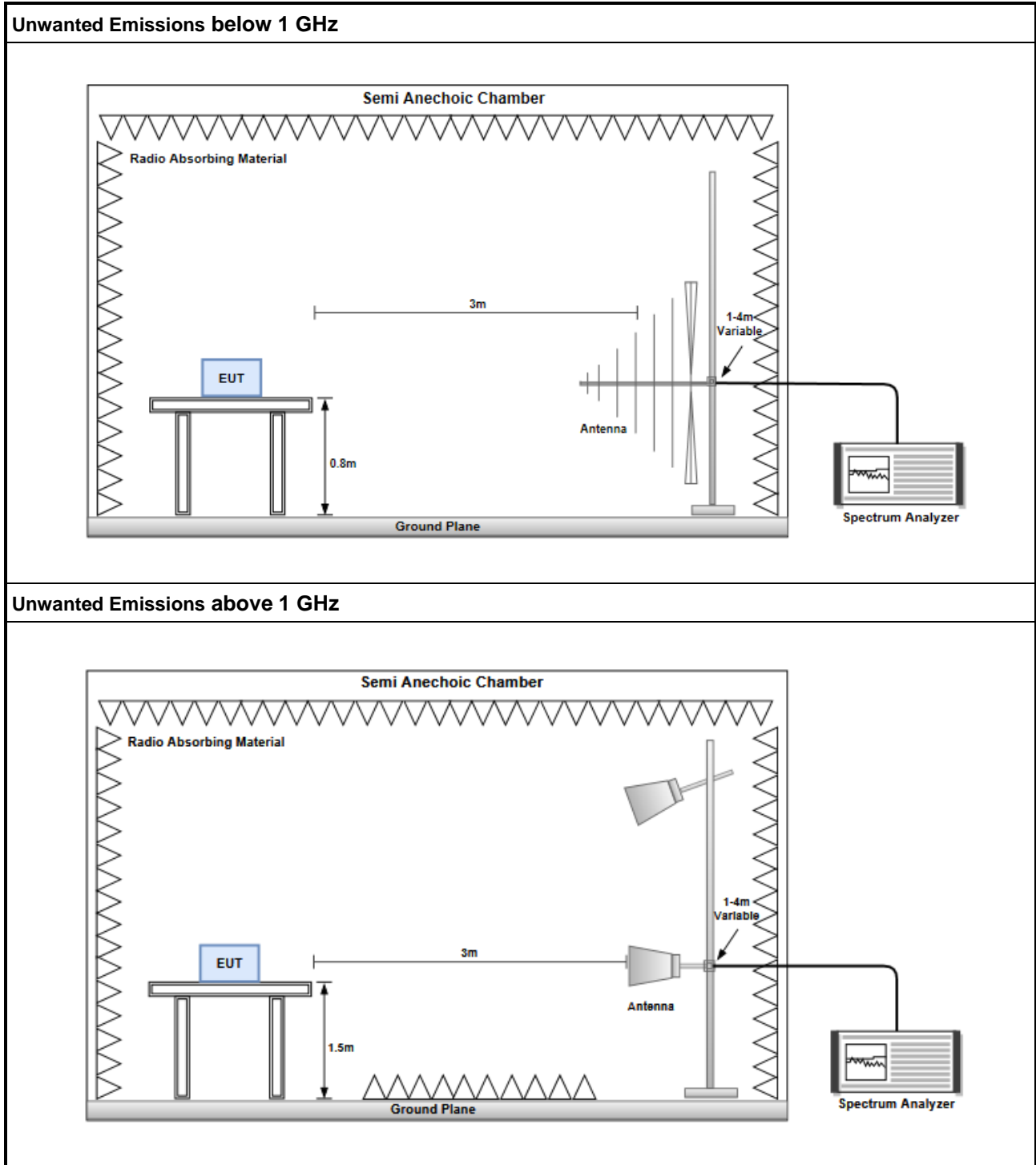

### 3.4.4 Test Results

Refer to Appendix D.

## 3.5 Frequency Stability

### 3.5.1 Limit of Frequency Stability

Manufacturers of U-NII devices are responsible for ensuring frequency stability such that an emission is maintained within the band of operation under all conditions of normal operation as specified in the user's manual.

### 3.5.2 Test Procedures

1. The EUT is installed in an environment test chamber with external power source.
2. Set the chamber to operate at 20 centigrade and external power source to output at nominal voltage of EUT.
3. A sufficient stabilization period at each temperature is used prior to each frequency measurement.
4. When temperature is stabled, measure the frequency stability.
5. The test shall be performed under normal and extreme condition for temperature and voltage.

### 3.5.3 Test Setup

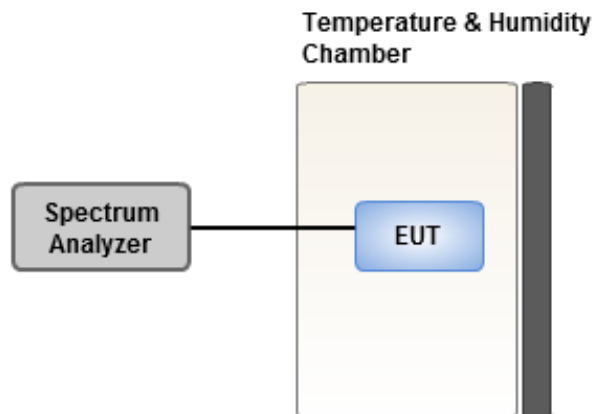

### 3.5.4 Test Results

<b>Ambient Condition</b>	24-25°C / 64-66%	<b>Tested By</b>	Akun Chung
--------------------------	------------------	------------------	------------

Refer to Appendix E.

## 3.6 AC Power Line Conducted Emissions

### 3.6.1 Limit of AC Power Line Conducted Emissions

Conducted Emissions Limit		
Frequency Emission (MHz)	Quasi-Peak	Average
0.15-0.5	66 - 56 *	56 - 46 *
0.5-5	56	46
5-30	60	50

Note 1: \* Decreases with the logarithm of the frequency.

### 3.6.2 Test Procedures

1. The device is placed on a test table, raised 80 cm above the reference ground plane. The vertical conducting plane is located 40 cm to the rear of the device.
2. The device is connected to line impedance stabilization network (LISN) and other accessories are connected to other LISN. Measured levels of AC power line conducted emission are across the 50  $\Omega$  LISN port.
3. AC conducted emission measurements is made over frequency range from 150 kHz to 30 MHz.
4. This measurement was performed with AC 120V/60Hz

### 3.6.3 Test Setup

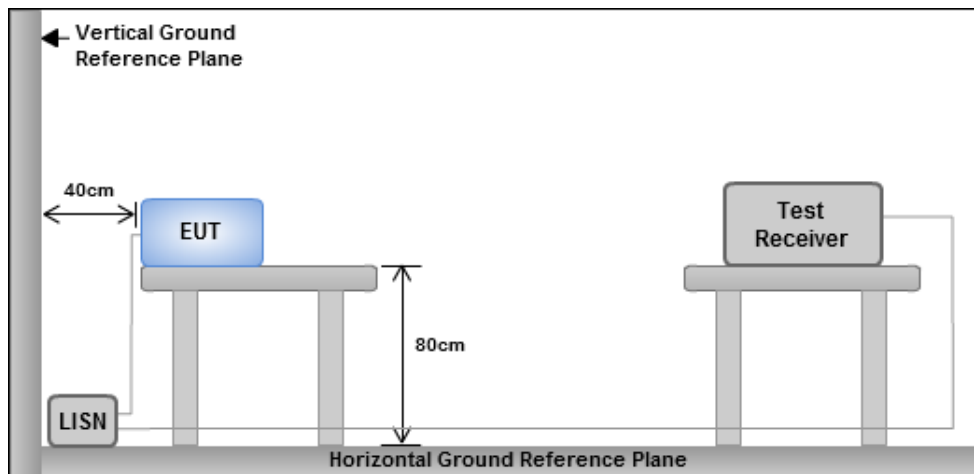

- Note: 1. Support units were connected to second LISN.  
2. Both of LISNs (AMN) are 80 cm from EUT and at least 80 cm from other units and other metal planes

### 3.6.4 Test Results

Refer to Appendix F.

## 4 Test laboratory information

Established in 2012, ICC provides foremost EMC & RF Testing and advisory consultation services by our skilled engineers and technicians. Our services employ a wide variety of advanced edge test equipment and one of the widest certification extents in the business.

International Certification Corporation (EMC and Wireless Communication Laboratory), it is our definitive objective is to institute long term, trust-based associations with our clients. The expectation we set up with our clients is based on outstanding service, practical expertise and devotion to a certified value structure. Our passion is to grant our clients with best EMC / RF services by oriented knowledgeable and accommodating staff.

Our Test sites are located at Linkou District and Kwei Shan District. Location map can be found on our website <http://www.icertifi.com.tw>.

### **Linkou**

Tel: 886-2-2601-1640

No.30-2, Ding Fwu Tsuen, Lin Kou  
District, New Taipei City, Taiwan  
(R.O.C.)

### **Kwei Shan**

Tel: 886-3-271-8666

No.3-1, Lane 6, Wen San 3rd  
St., Kwei Shan Dist., Tao Yuan  
City 33381, Taiwan (R.O.C.)  
No.2-1, Lane 6, Wen San 3rd  
St., Kwei Shan Dist., Tao Yuan  
City 33381, Taiwan (R.O.C.)

### **Kwei Shan Site II**

Tel: 886-3-271-8640

No.14-1, Lane 19, Wen San 3rd  
St., Kwei Shan Dist., Tao Yuan  
City 33381, Taiwan (R.O.C.)

If you have any suggestion, please feel free to contact us as below information.

Tel: 886-3-271-8666

Fax: 886-3-318-0345

Email: ICC\_Service@icertifi.com.tw

==END==