

Antenna Test Report

WBE660S

(D047)

Document Number: NE3-22064

Version: V 2.03

Released Date: 2023/08/15

Prepared By: Wei Hsu

Reviewed By: Tim Cheng

Contents

- Revised History
- Specification
- Antenna Placement & Solution
- Test Setup for S-parameter Measurement
- Return Loss Results
- Isolation Results
- Test Setup for Radiation Pattern Measurement
- 2D Radiation Pattern Results
- Results Summary (return loss, isolation, peak gain, efficiency)

Revision History

Released Date	Version	Record
2022/09/02	1.00	Antenna evaluation report
2022/09/08	1.01	Antenna evaluation report (PCB type S-parameter only)
2023/02/15	2.01	Antenna testing with real environment
2023/05/12	2.02	Antenna testing with new housing
2023/08/03	2.03	Add H-polarization & V-polarization peak gain (For FCC)
2023/08/15	2.03	Update test report

Specification

Requirements of Antenna Design

RF Function	Number of ANT	Frequency Band	Remark
WiFi 2G	4	2400-2500 MHz	PCB
WiFi 5G	6	5150-5850 MHz	PCB
WiFi 6G	6	5925-7125 MHz	PCB
BT	11	2400-2500 MHz	PCB

Requirements of Measurement

Test Item	Specification	Remark
Return Loss	2GHz > 10 dB ; 5GHz > 10 dB ; 6GHz > 8 dB ; BT > 5dB	
Isolation	2G-2G / 5G-5G / 6G-6G >15 dB 2G-5G / 2G-6G <10 dB 5G-6G >25 dB	
Peak gain	NA	
Efficiency	NA	
Radiation pattern	Scale:+10~-40dBi, Angle step size: 5 degree	

Antenna Placement & Solution

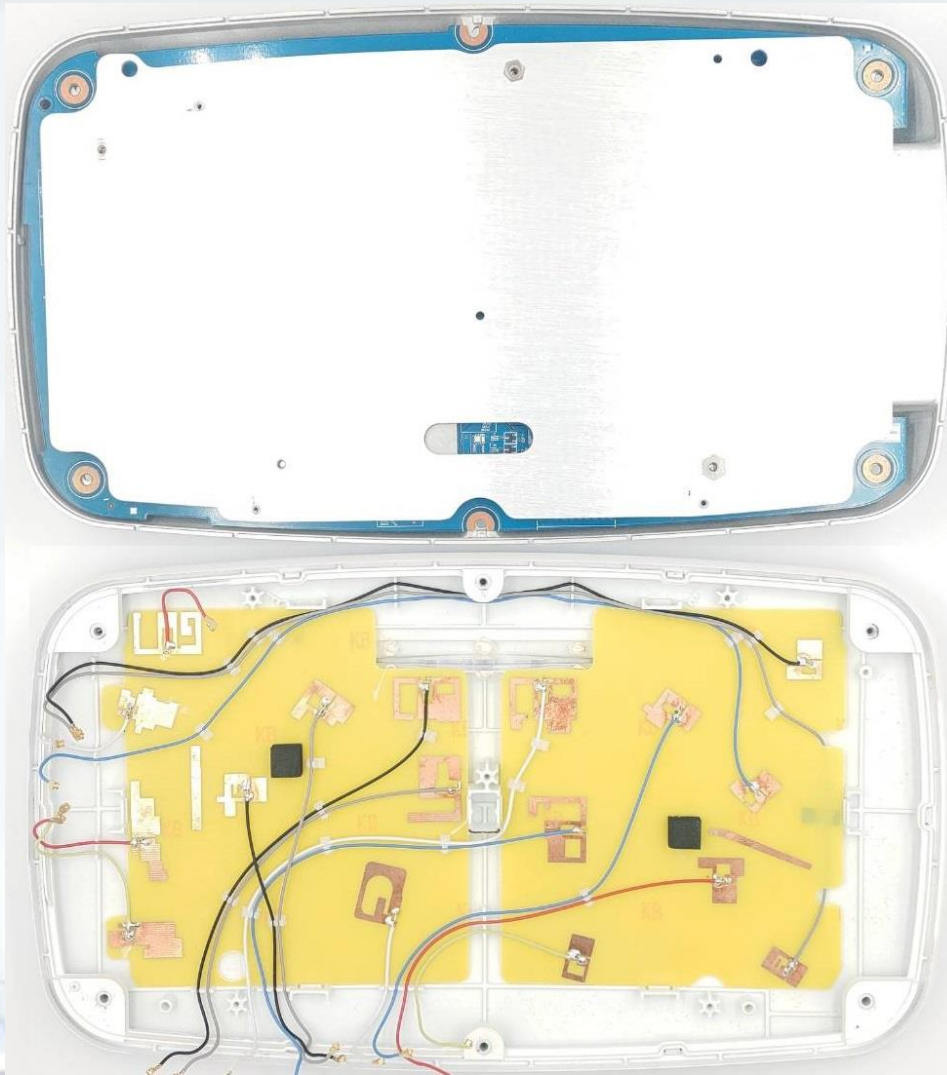

Antenna Placement & Solution

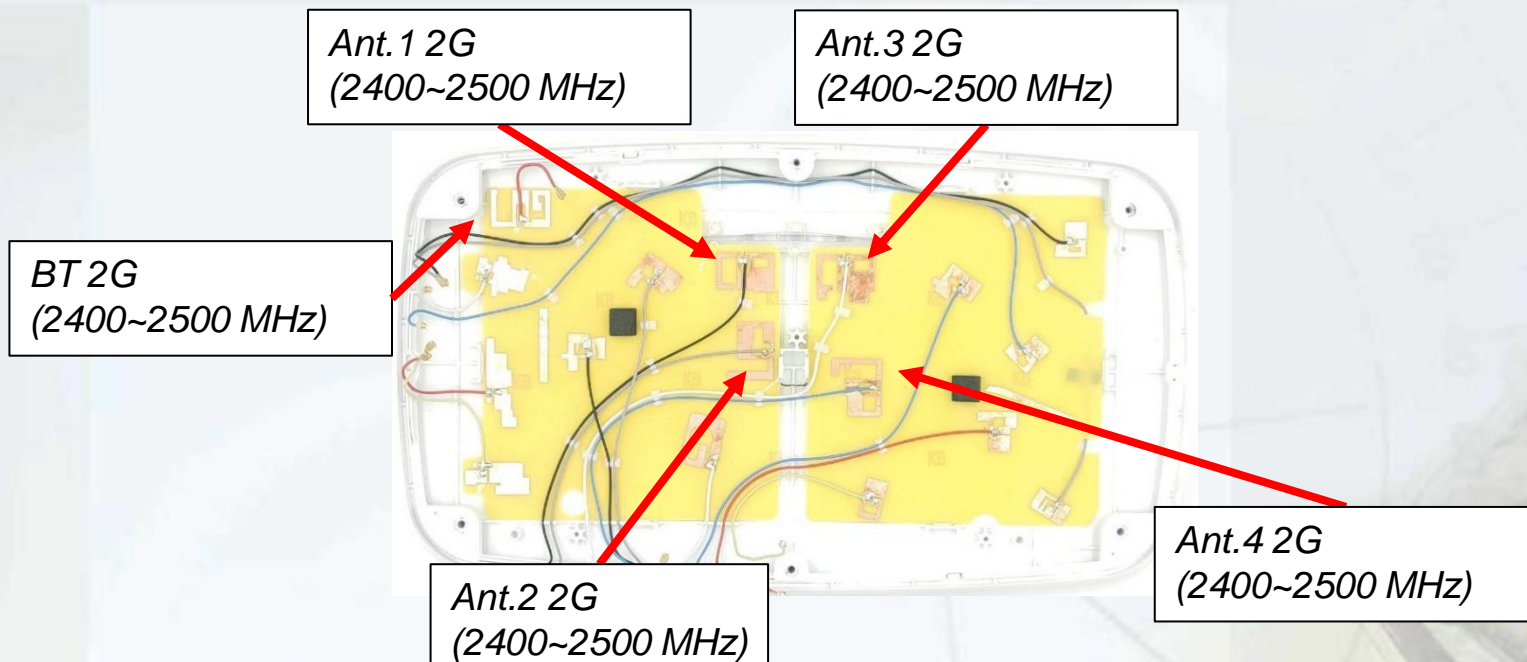

Antenna	ANT Type	Size (L * W * H* T)	Cable Length (mm)	Cable Type
Ant.1	PCB	NA	186 mm	Φ=1.13mm(LL)
Ant.2	PCB	NA	165 mm	Φ=1.13mm(LL)
Ant.3	PCB	NA	224 mm	Φ=1.13mm (LL)
Ant.4	PCB	NA	197 mm	Φ=1.13mm (LL)
BT	PCB	NA	50 mm	Φ=1.13mm (LL)

Antenna Placement & Solution

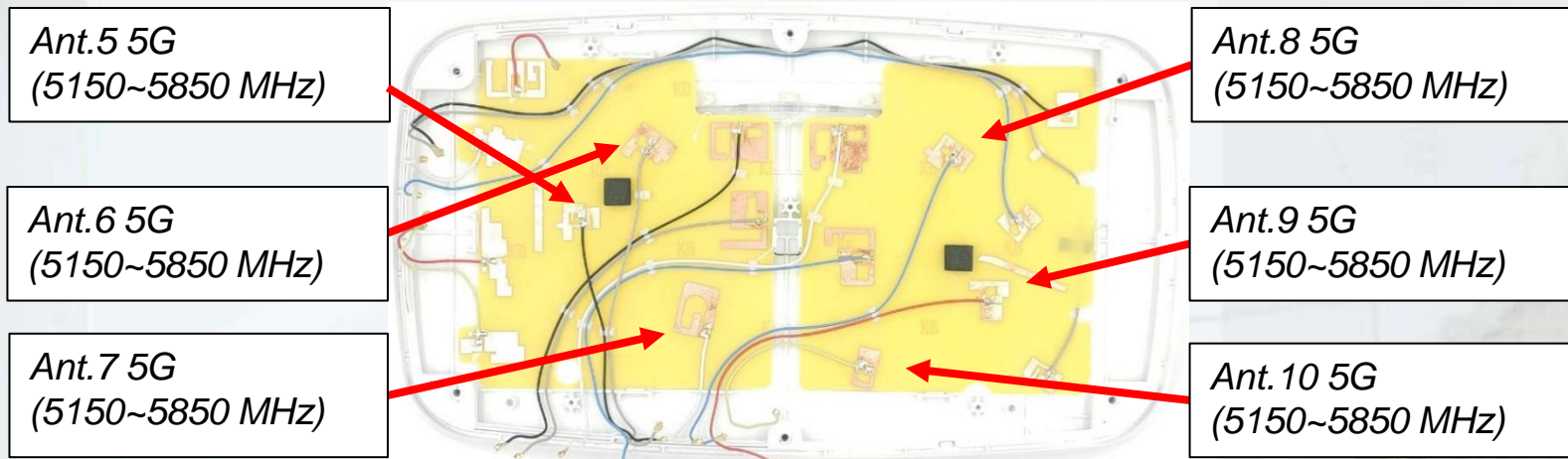

Antenna	ANT Type	Size (L * W * H* T)	Cable Length (mm)	Cable Type
Ant.5	PCB	NA	116 mm	Φ=1.13mm(LL)
Ant.6	PCB	NA	149 mm	Φ=1.13mm(LL)
Ant.7	PCB	NA	75 mm	Φ=1.13mm (LL)
Ant.8	PCB	NA	200 mm	Φ=1.13mm (LL)
Ant.9	PCB	NA	177 mm	Φ=1.13mm (LL)
Ant.10	PCB	NA	130 mm	Φ=1.13mm (LL)

Antenna Placement & Solution

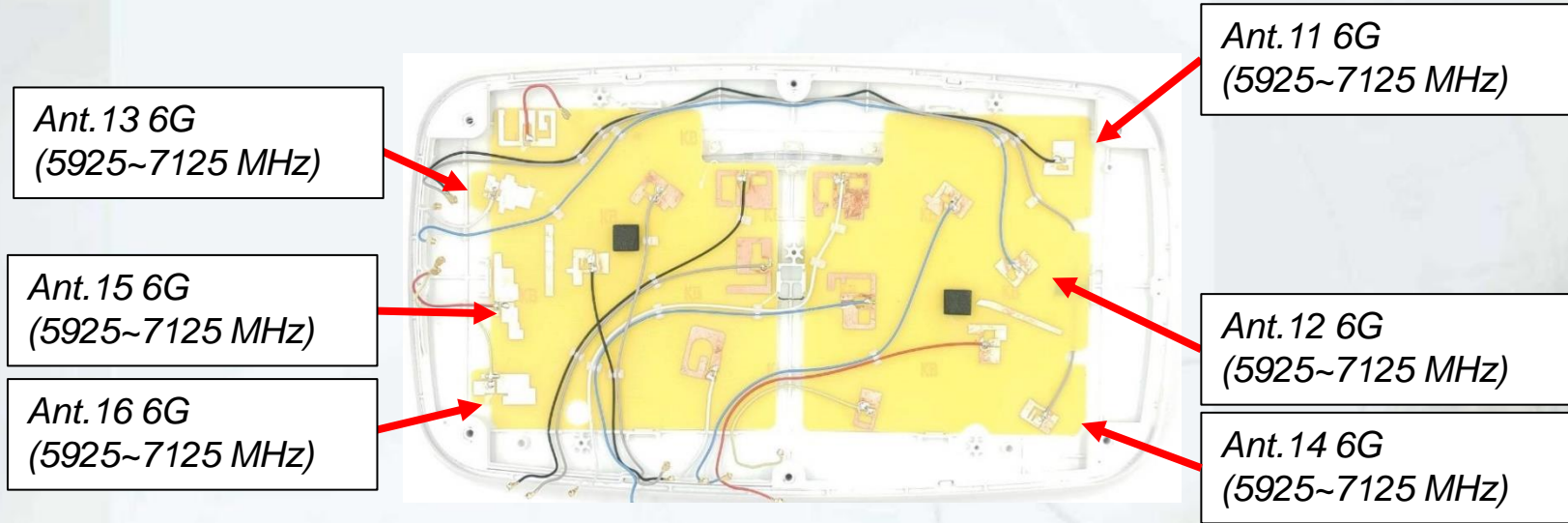

Antenna	ANT Type	Size (L * W * H* T)	Cable Length (mm)	Cable Type
Ant.11	PCB	NA	303 mm	Φ=1.13mm(LL)
Ant.12	PCB	NA	407 mm	Φ=1.13mm(LL)
Ant.13	PCB	NA	64 mm	Φ=1.13mm (LL)
Ant.14	PCB	NA	338 mm	Φ=1.13mm (LL)
Ant.15	PCB	NA	62 mm	Φ=1.13mm (LL)
Ant.16	PCB	NA	83 mm	Φ=1.13mm (LL)

Test Setup for S-parameter Measurement

Equipment	Brand	Model	S/N
Network Analyzer	Keysight	E5063A	MY54706080



Return Loss Results

Ant.1 (2400-2500 MHz)

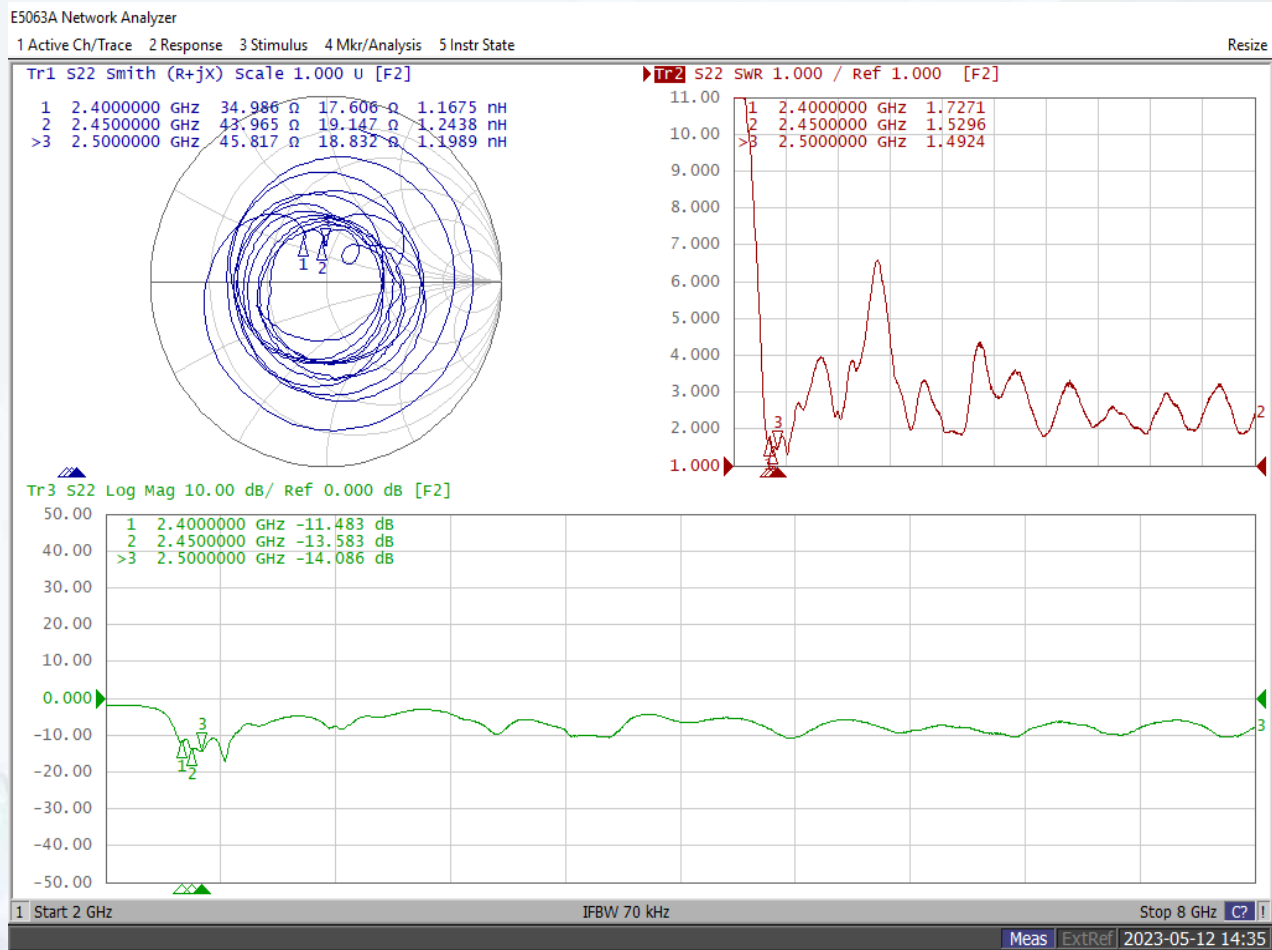

Return Loss Results

Ant.2 (2400-2500 MHz)

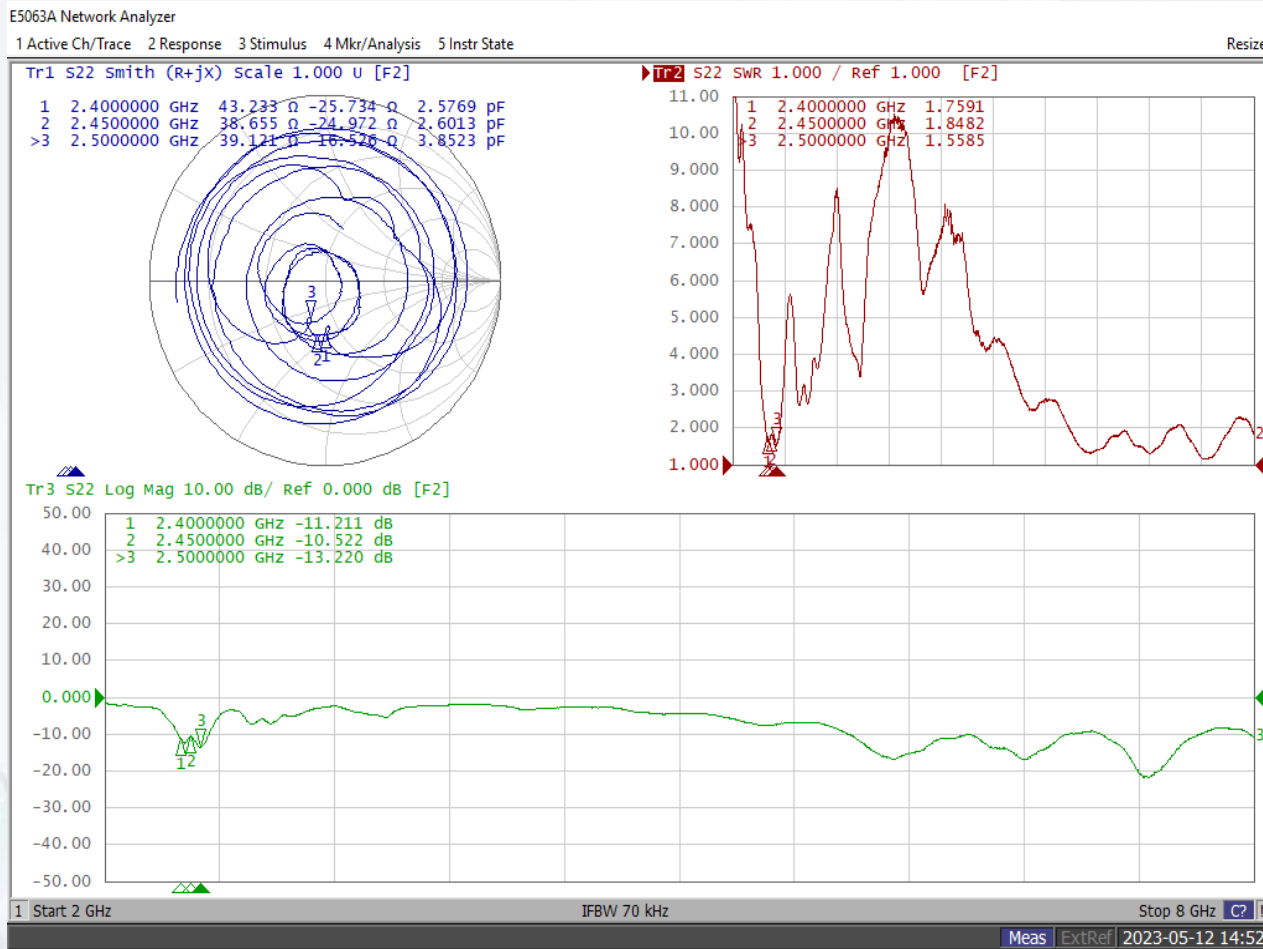

Return Loss Results

Ant.3 (2400-2500 MHz)

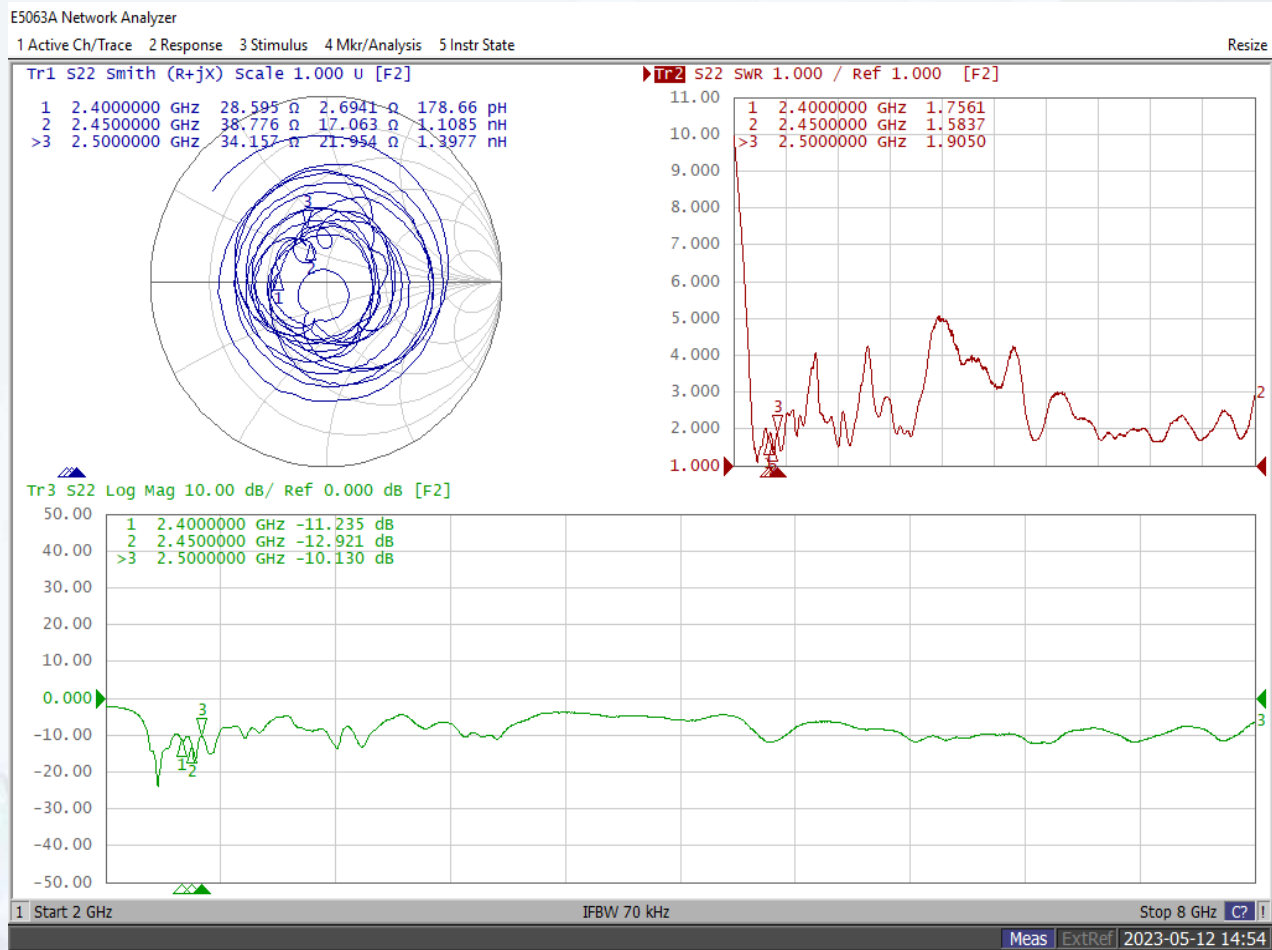

Return Loss Results

Ant.4 (2400-2500 MHz)

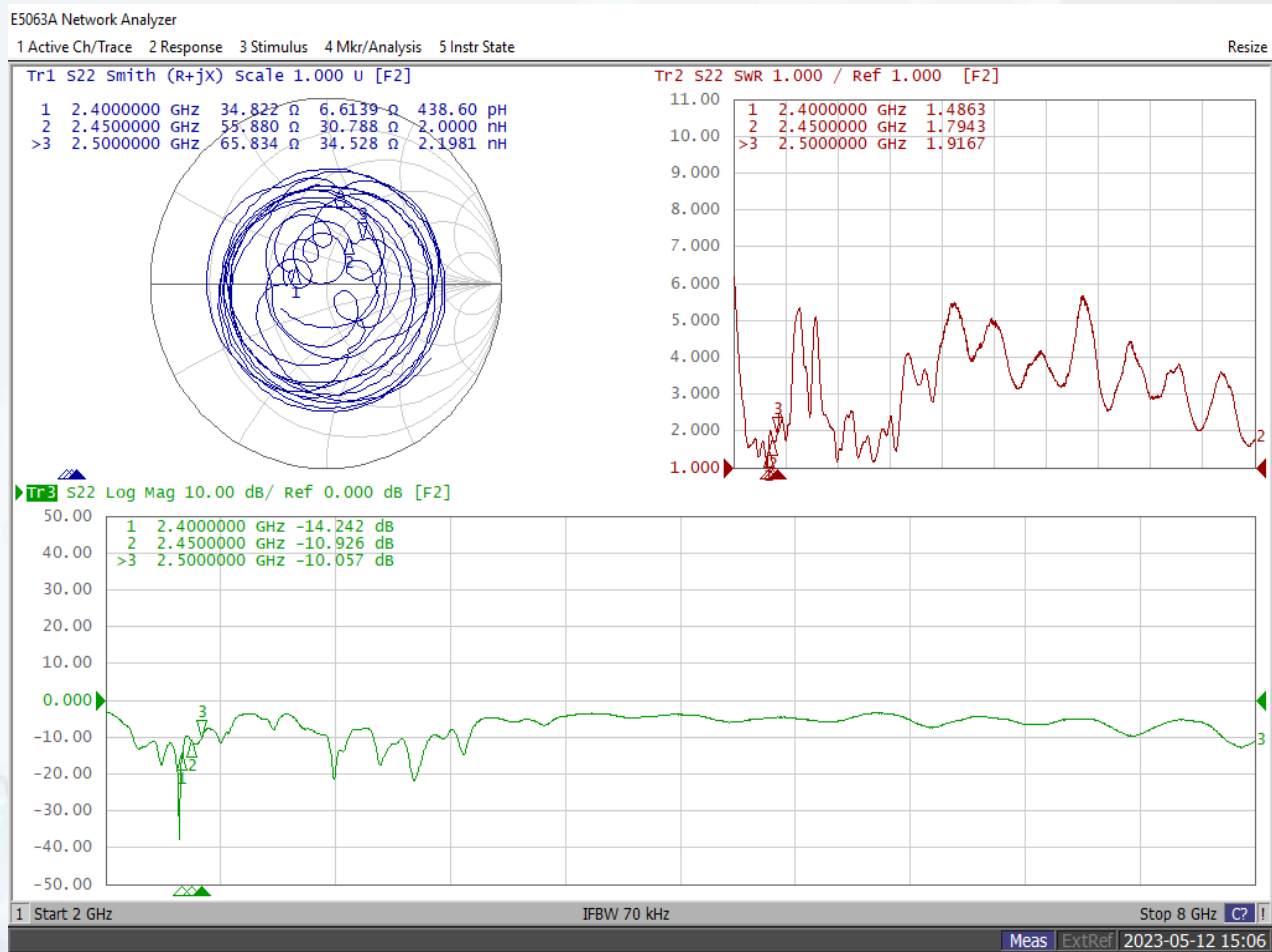

Return Loss Results

Ant.5 (5150-5850MHz)

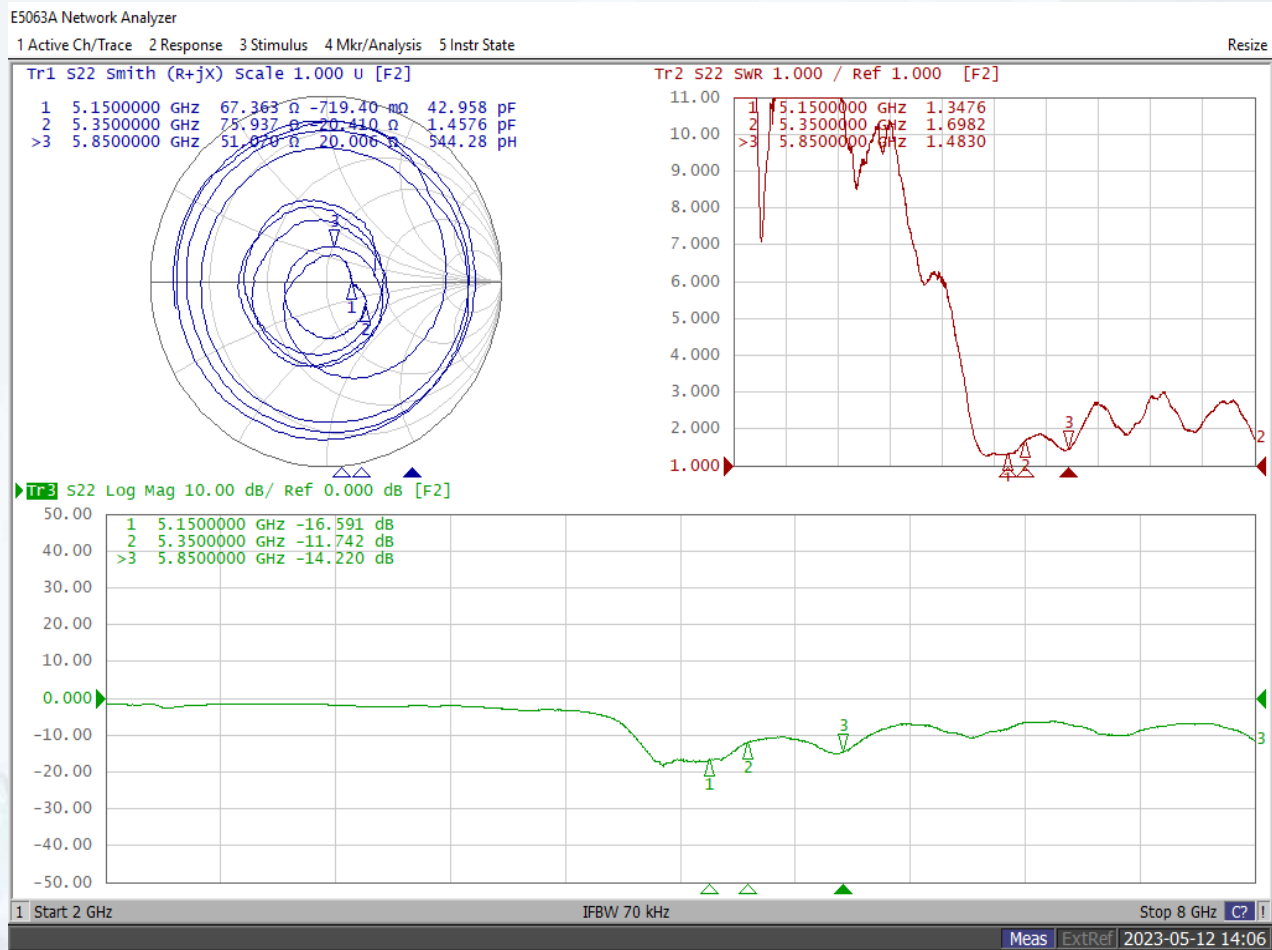

Return Loss Results

Ant.6 (5150-5850MHz)

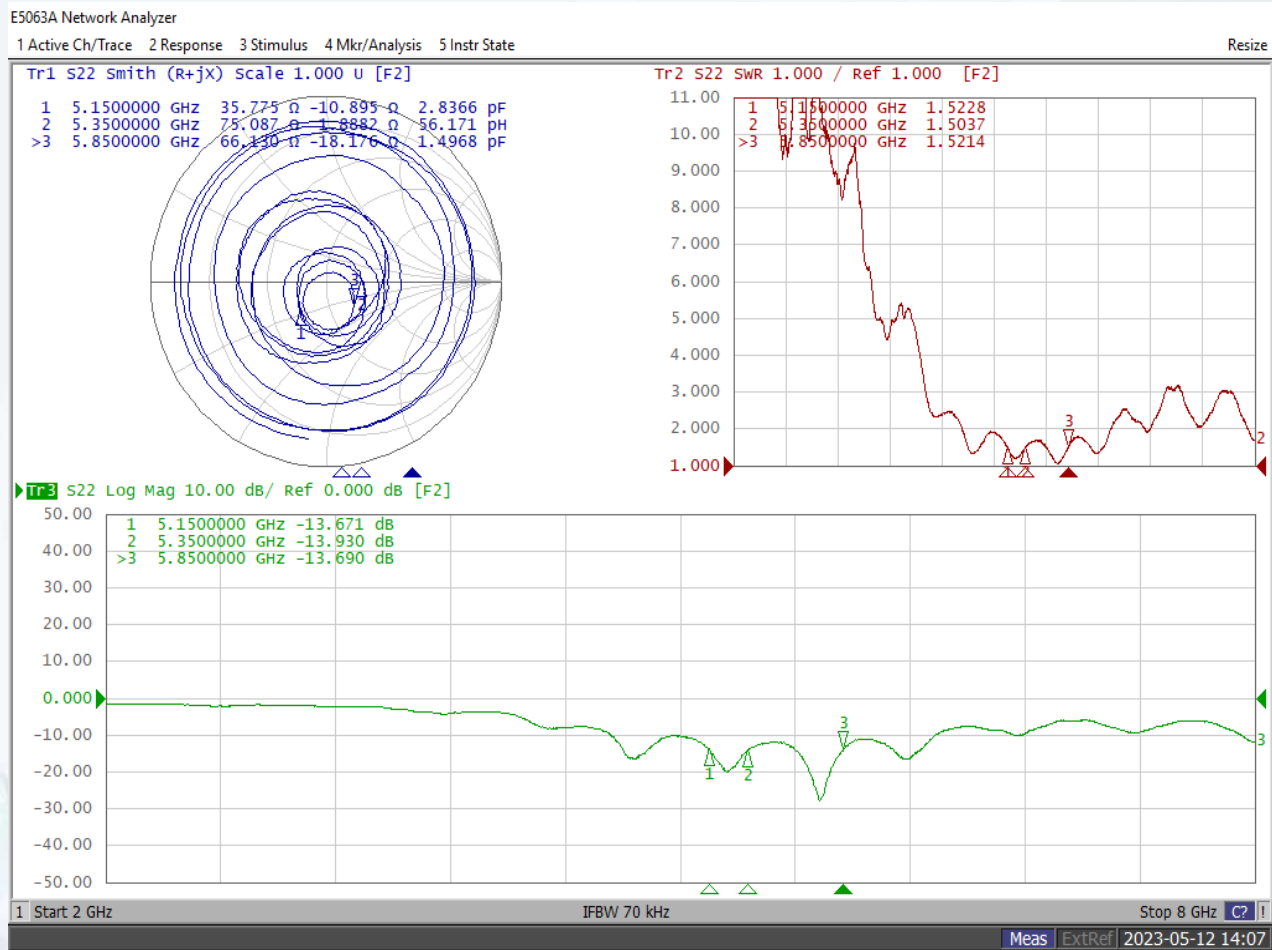

Return Loss Results

Ant.7 (5150-5850MHz)

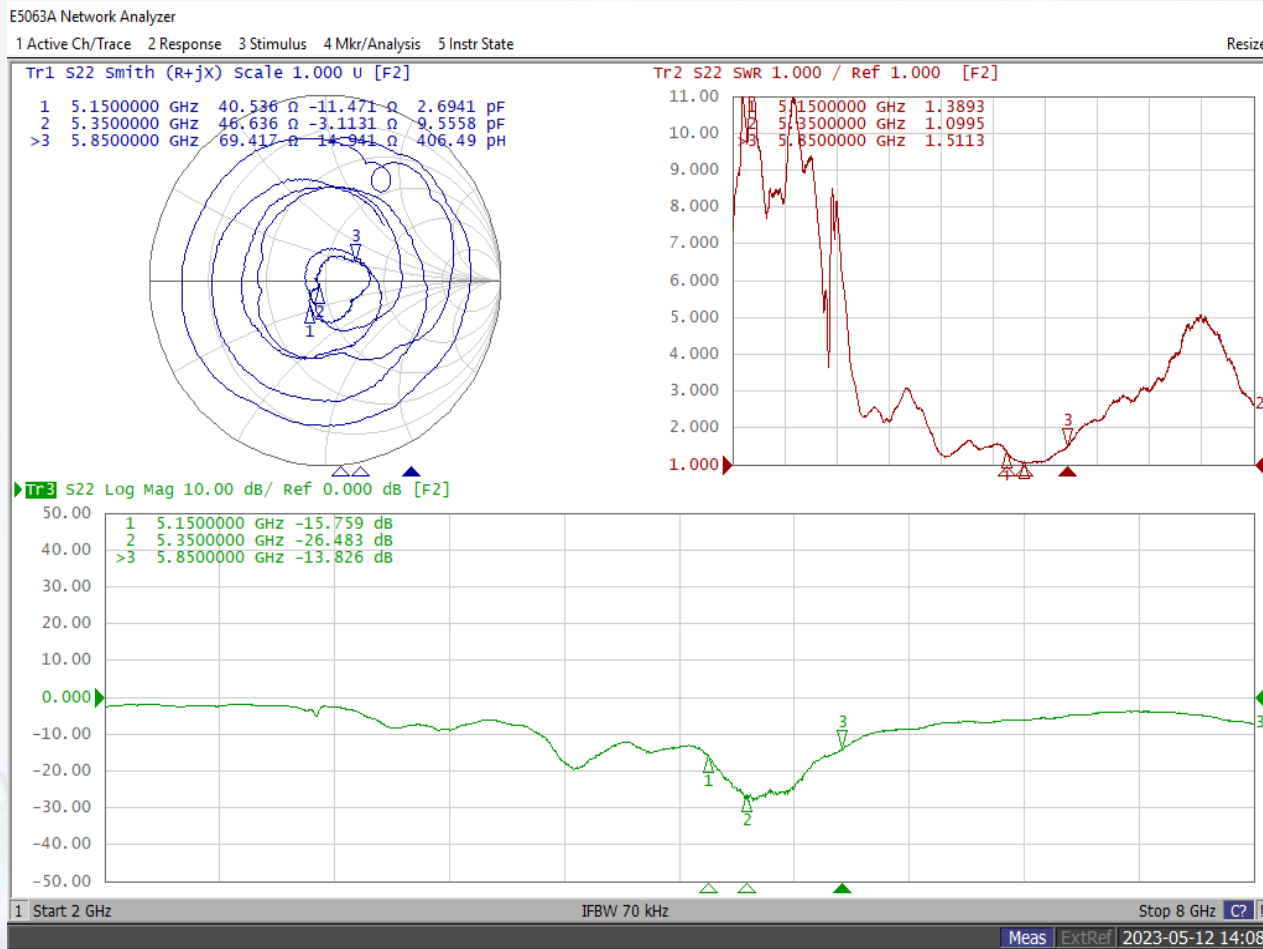

Return Loss Results

Ant.8 (5150-5850MHz)

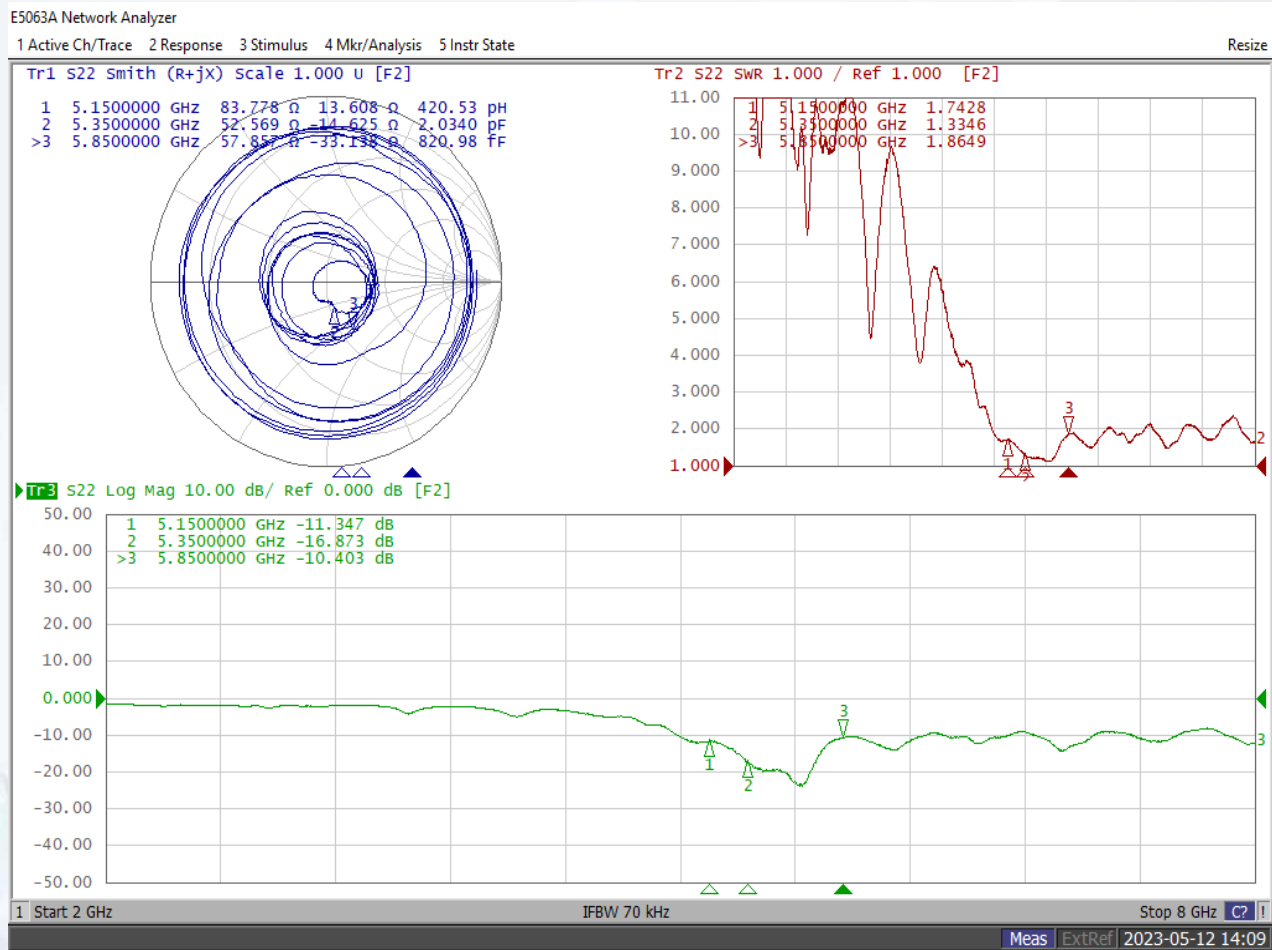

Return Loss Results

Ant.9 (5150-5850MHz)

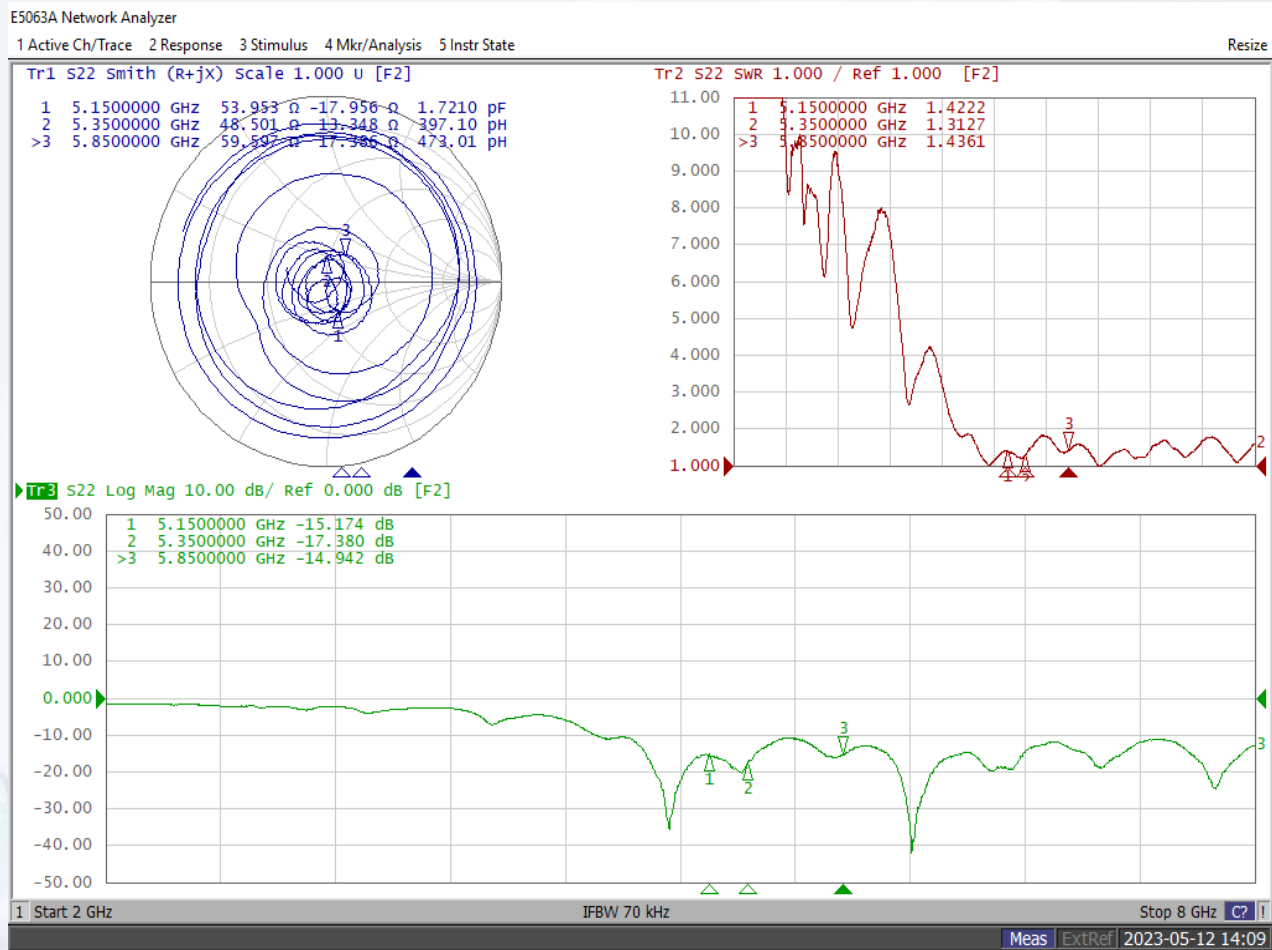

Return Loss Results

Ant.10 (5150-5850MHz)

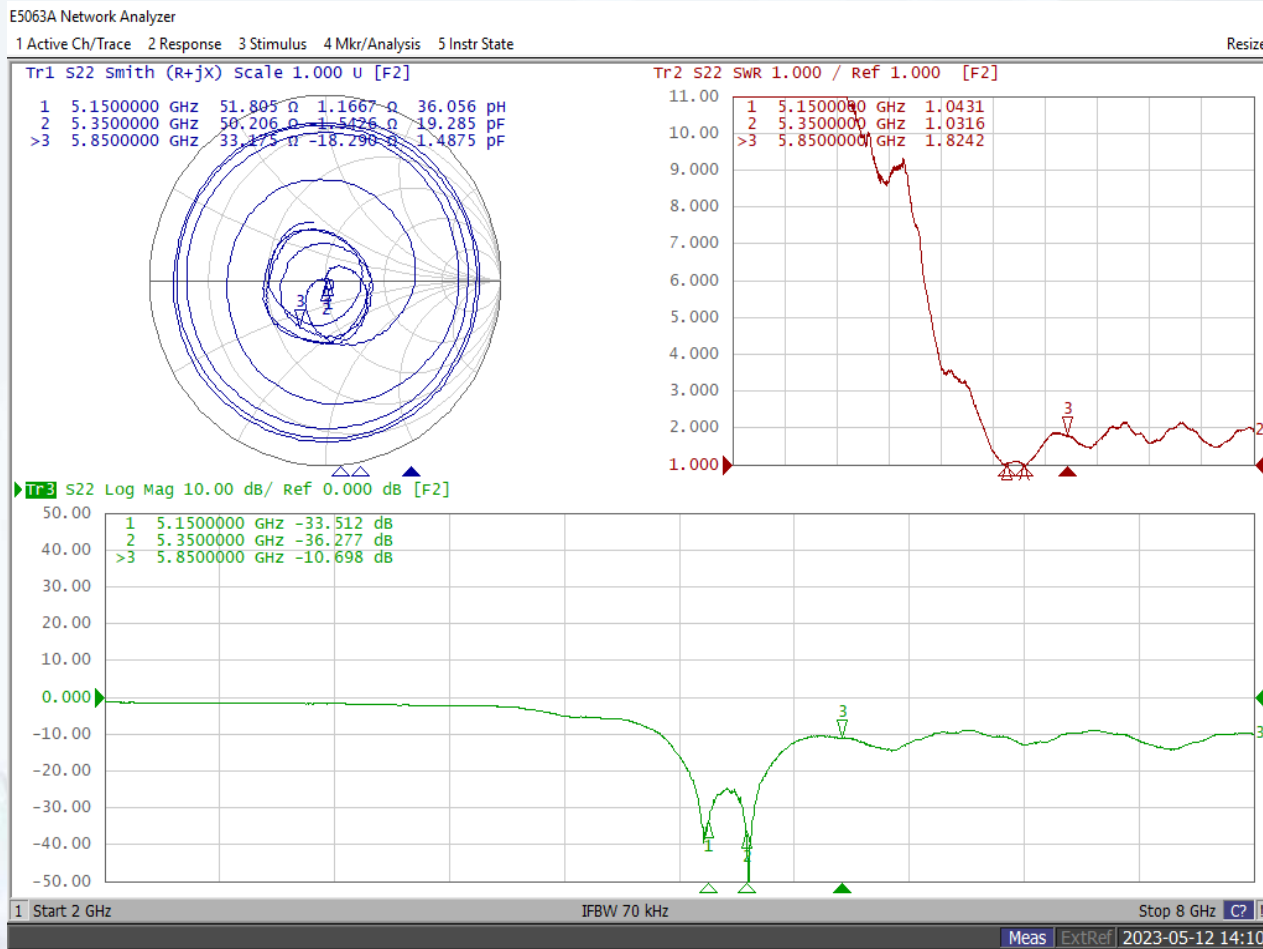

Return Loss Results

Ant.11 (5925-7125MHz)

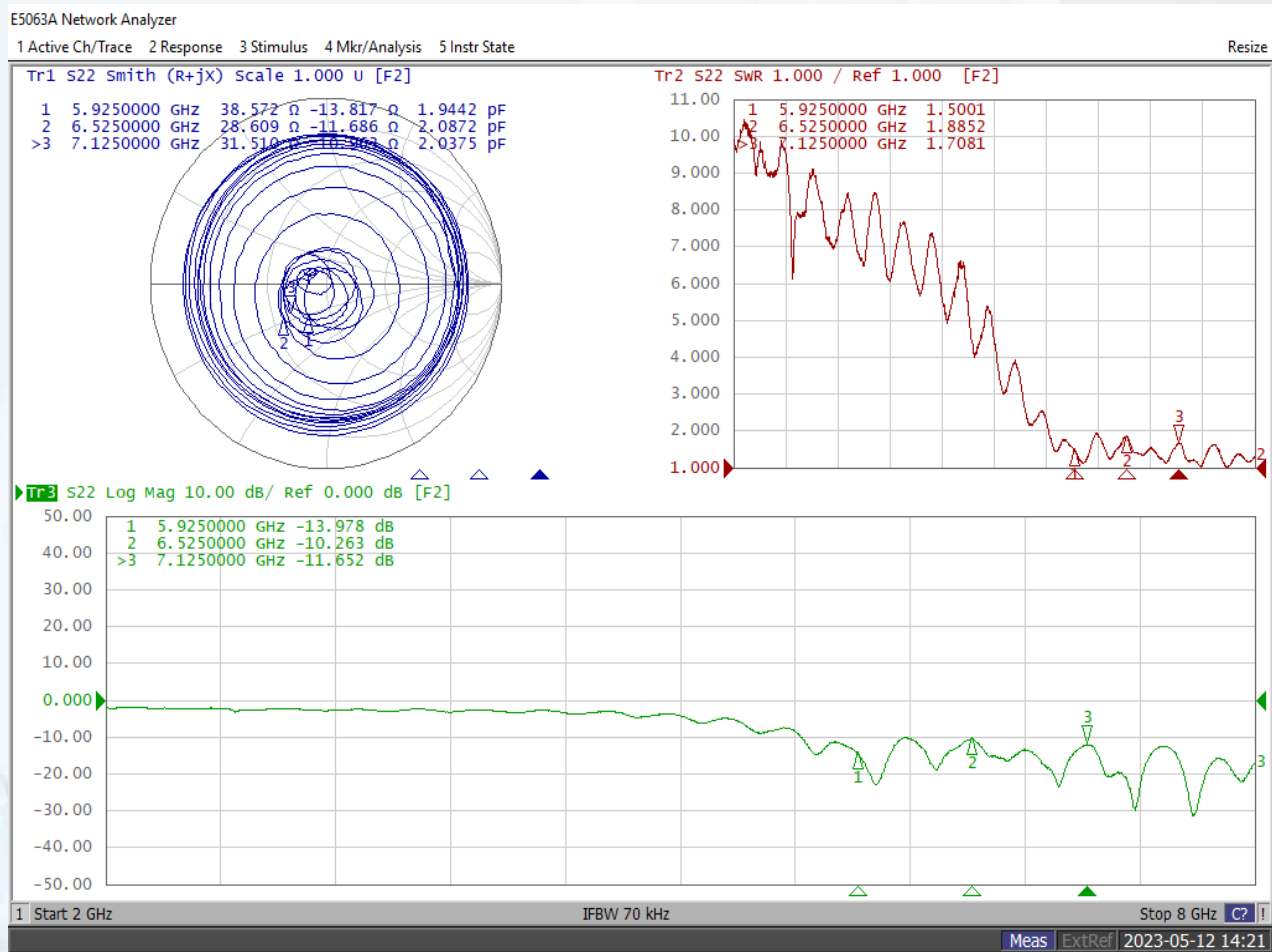

Return Loss Results

Ant.12 (5925-7125MHz)

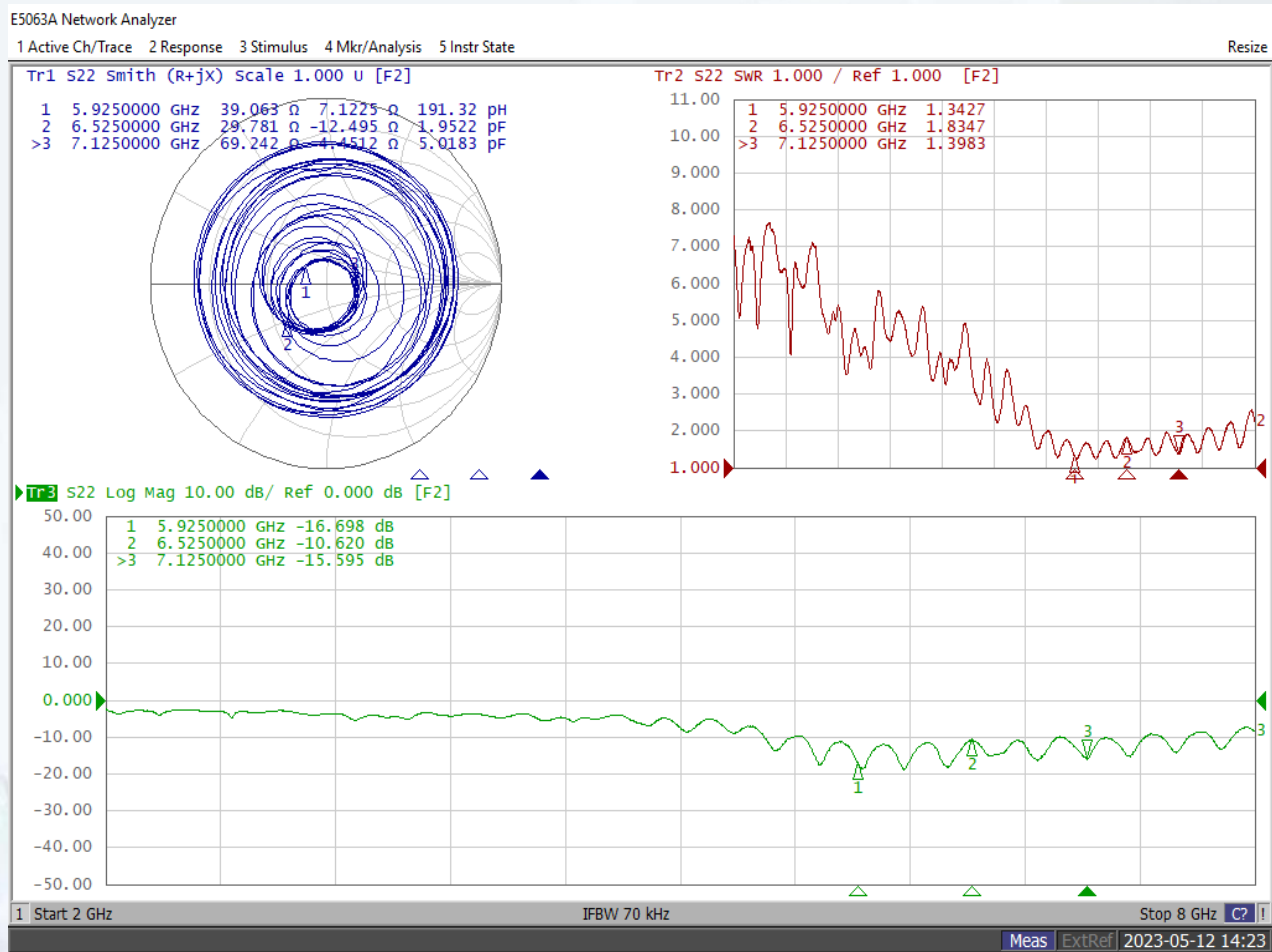

Return Loss Results

Ant.13 (5925-7125MHz)

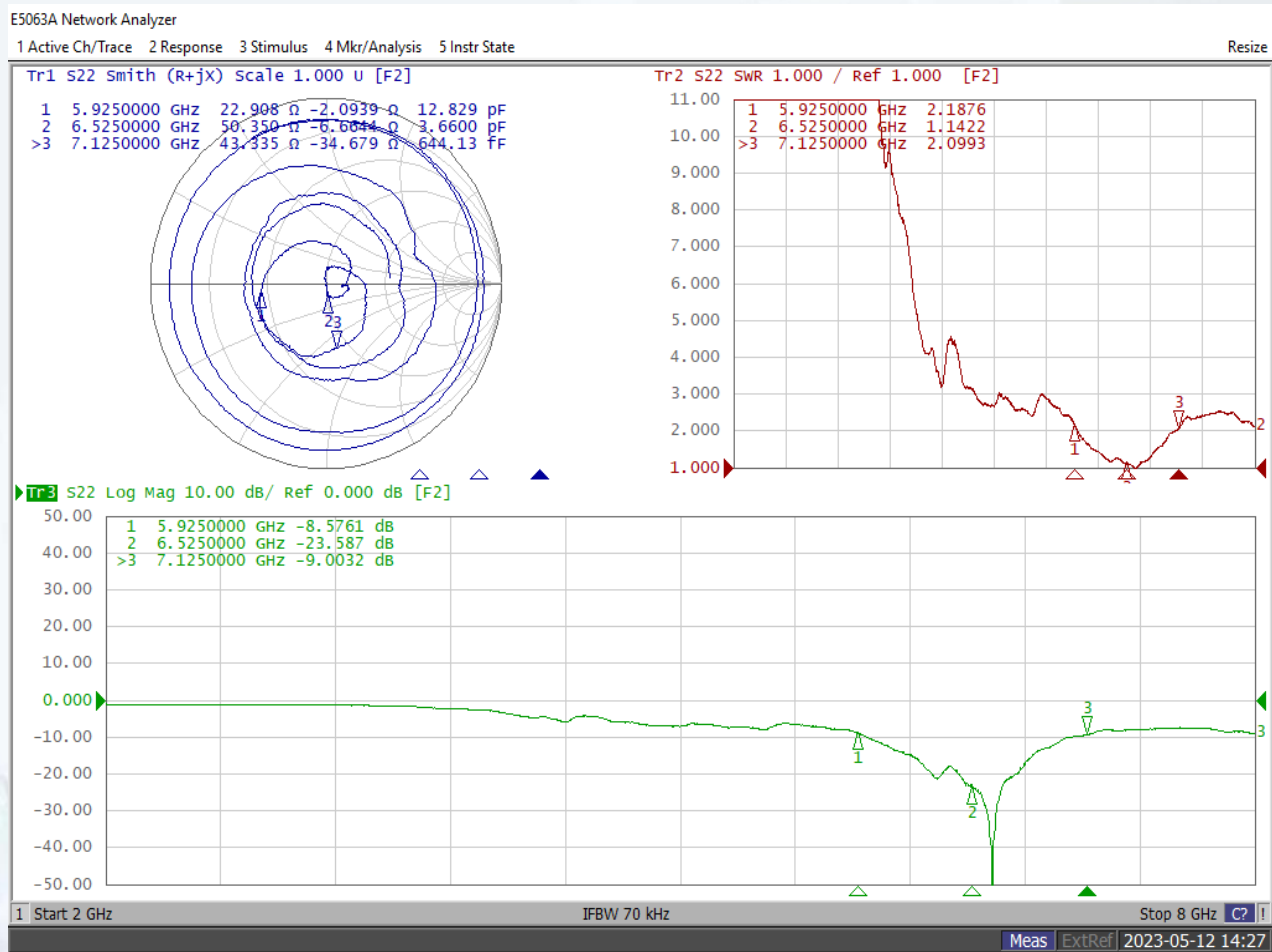

Return Loss Results

Ant.14 (5925-7125MHz)

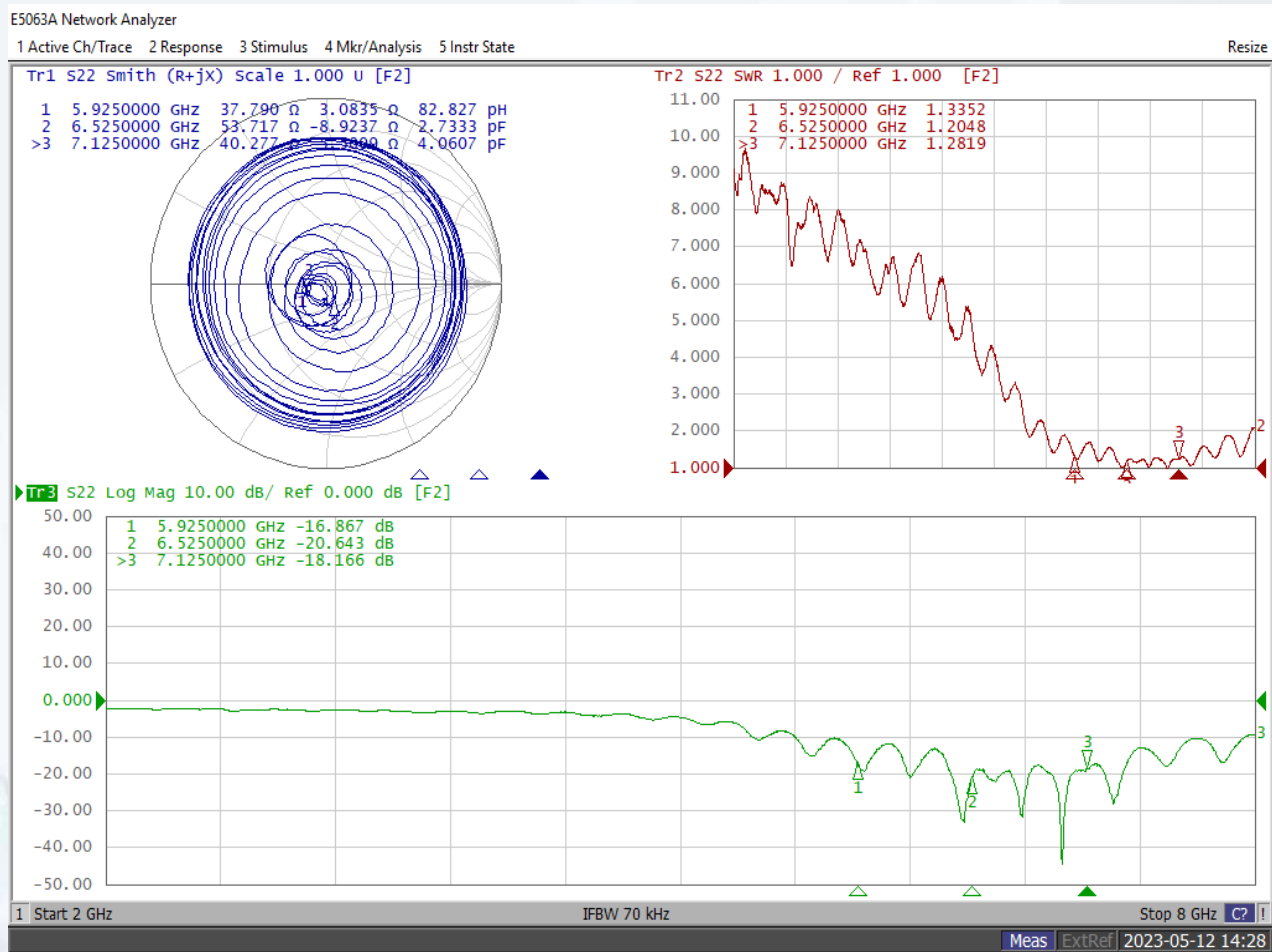

Return Loss Results

Ant.15 (5925-7125MHz)

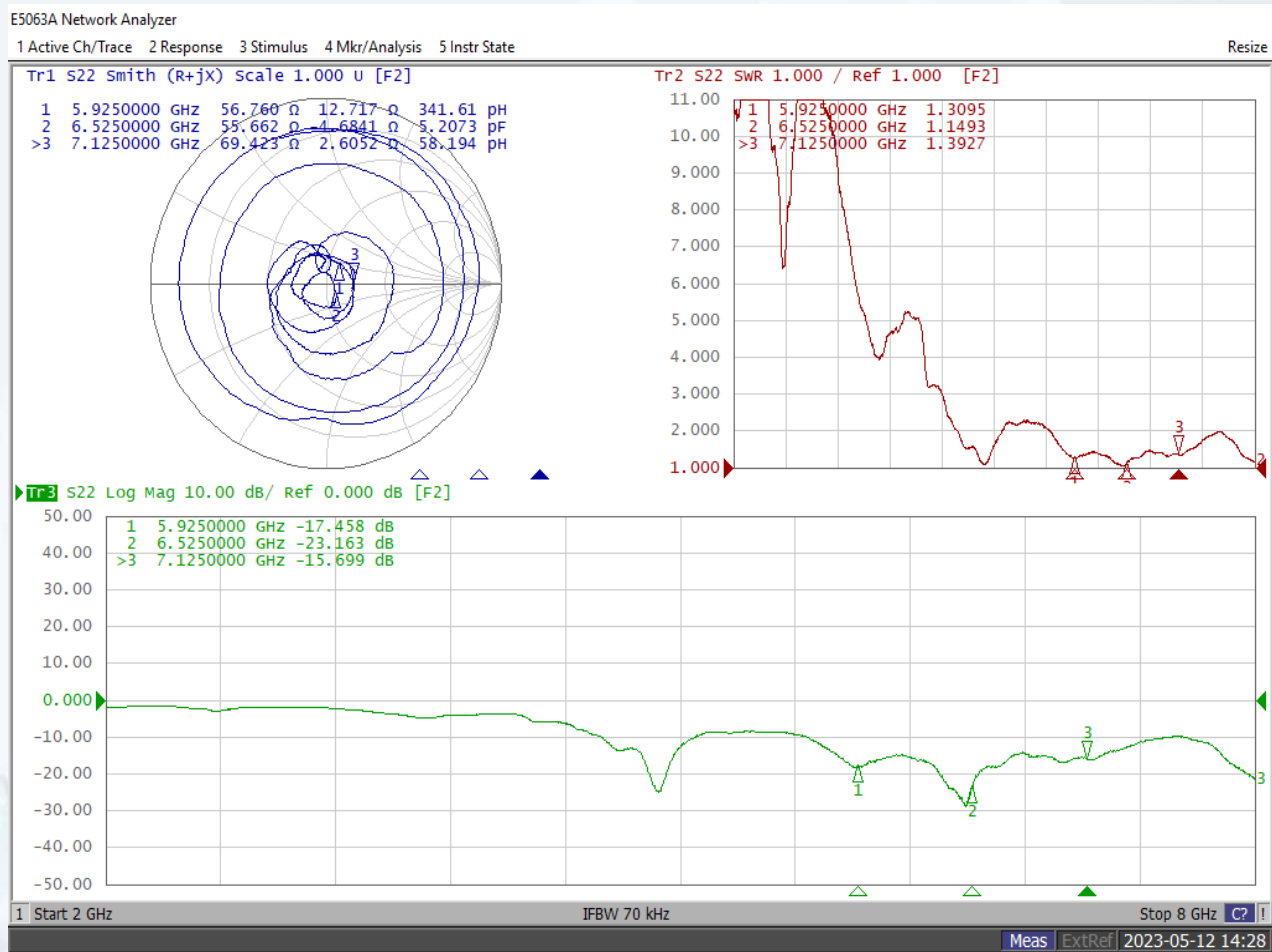

Return Loss Results

Ant.16 (5925-7125MHz)

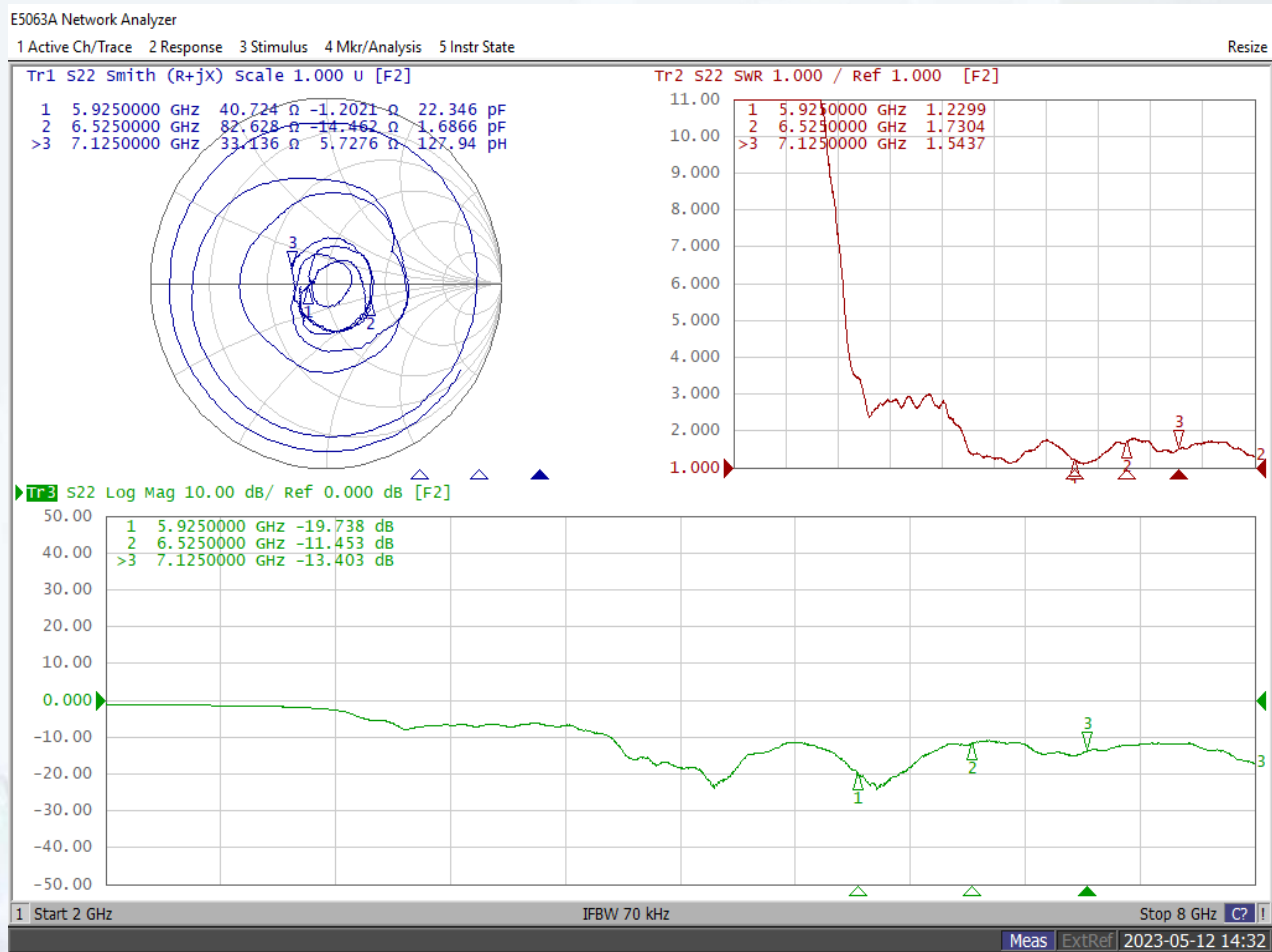

Return Loss Results

BT (2400-2500MHz)

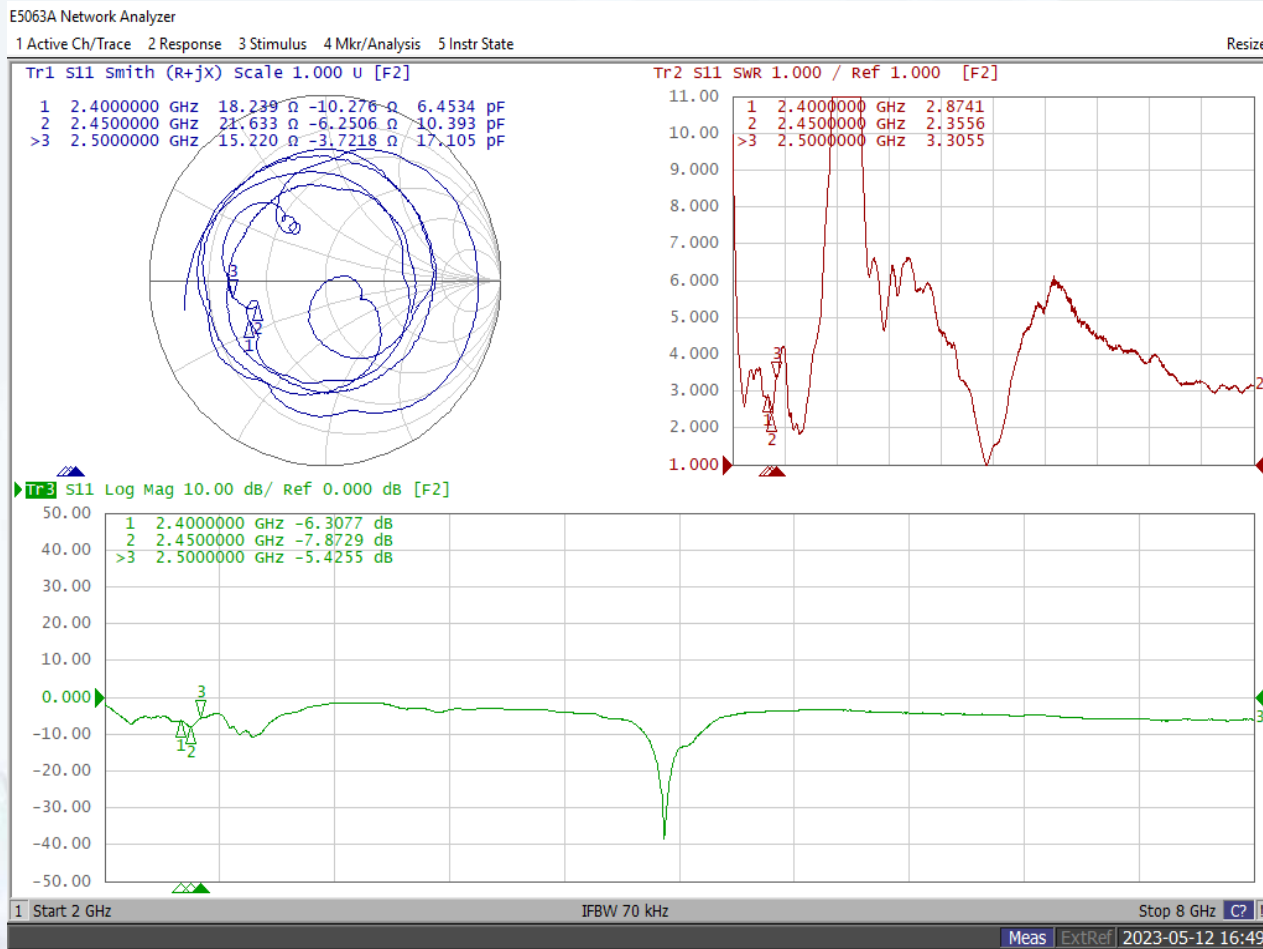

Isolation Results

2G to 2G

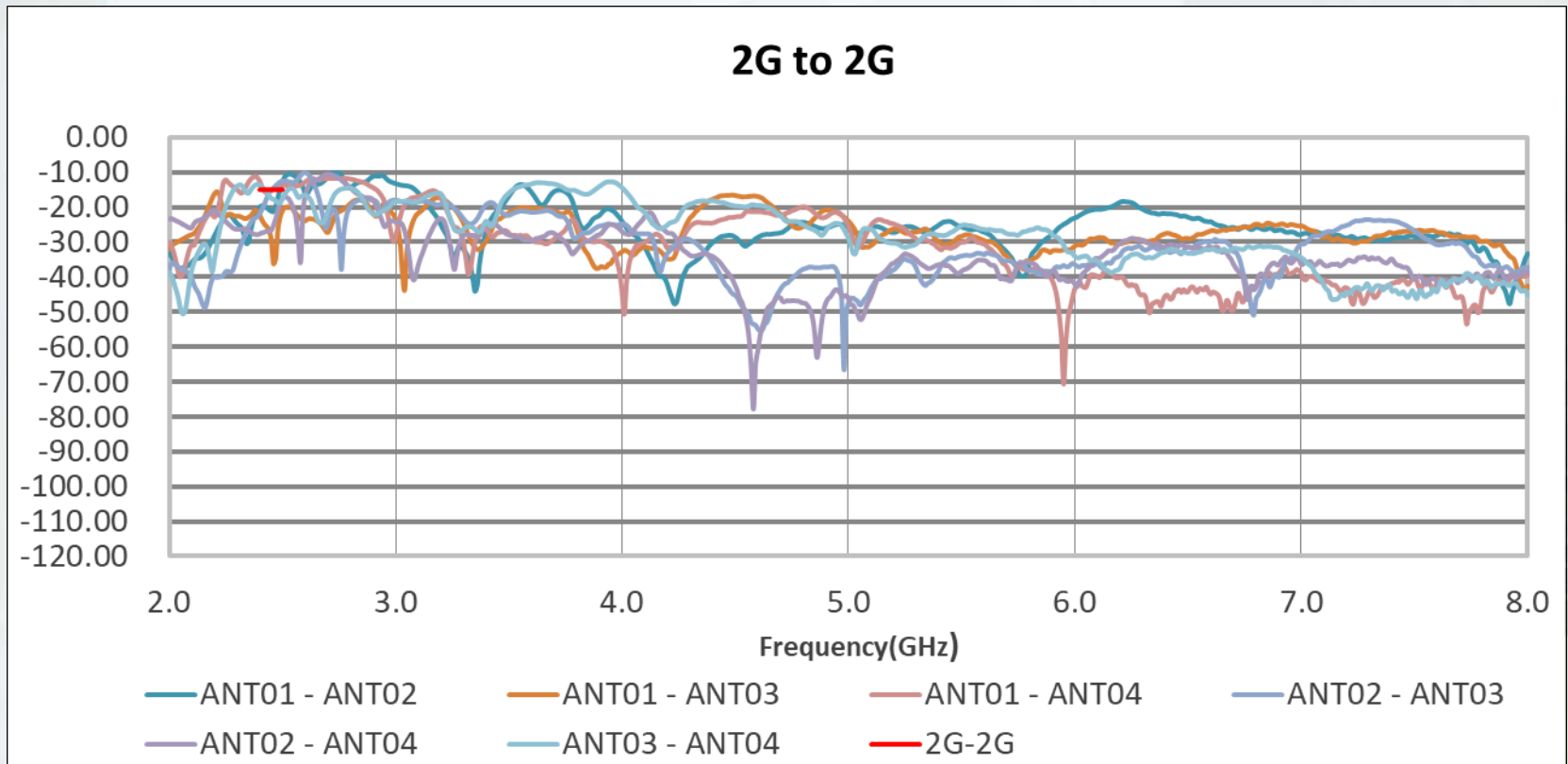

Isolation Results

5G to 5G

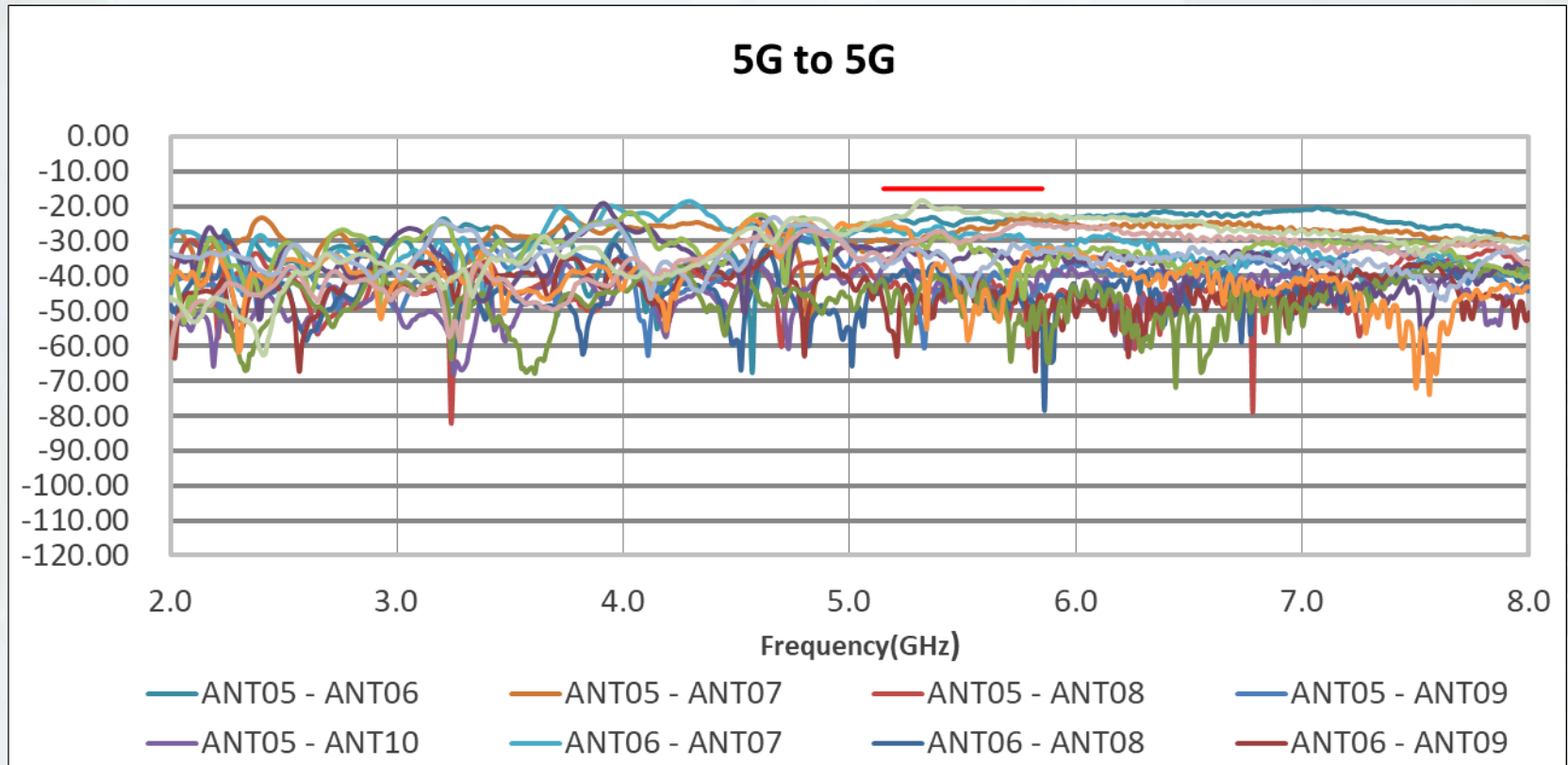

Isolation Results

6G to 6G

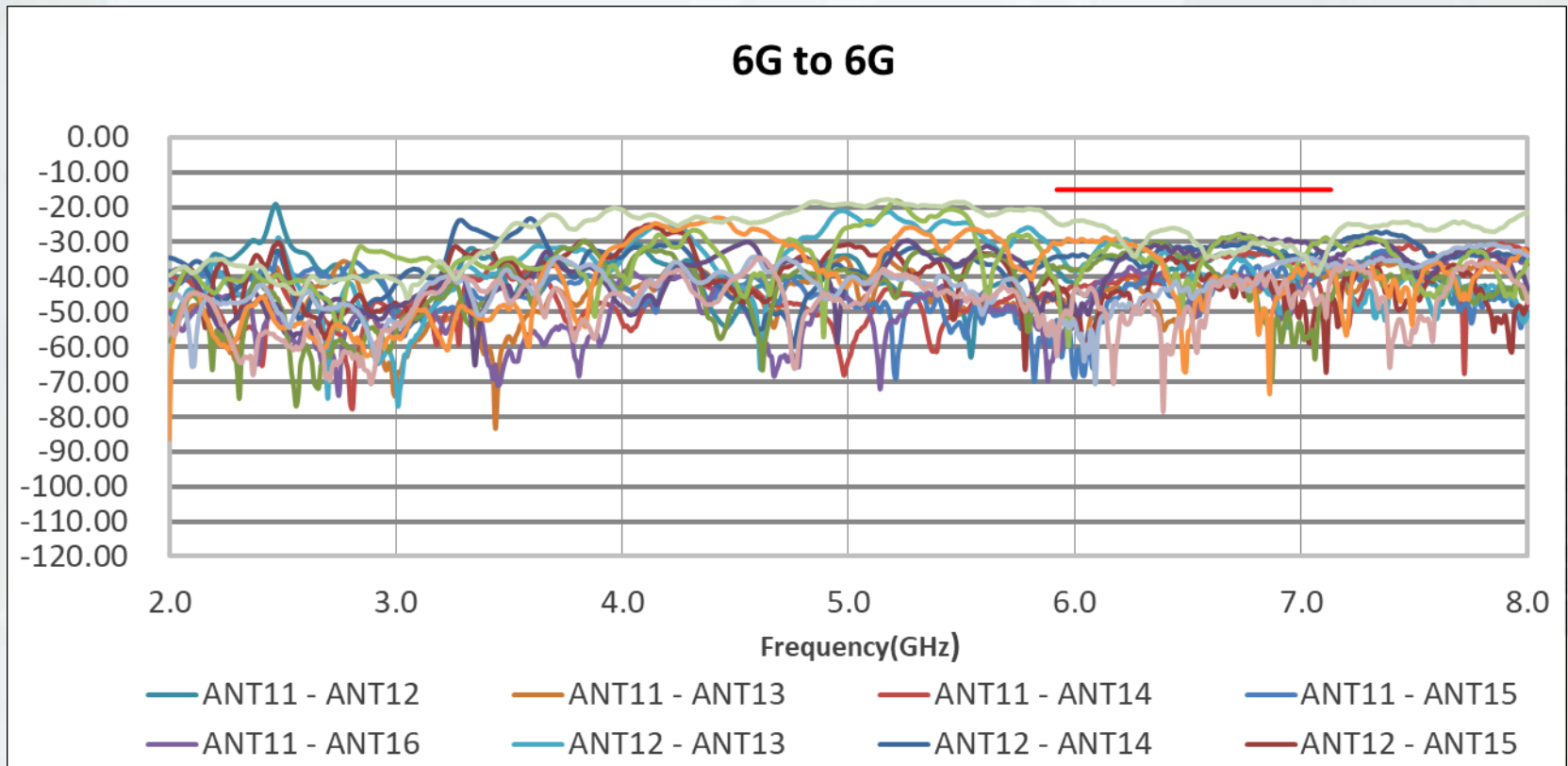

Isolation Results

2G to 5G

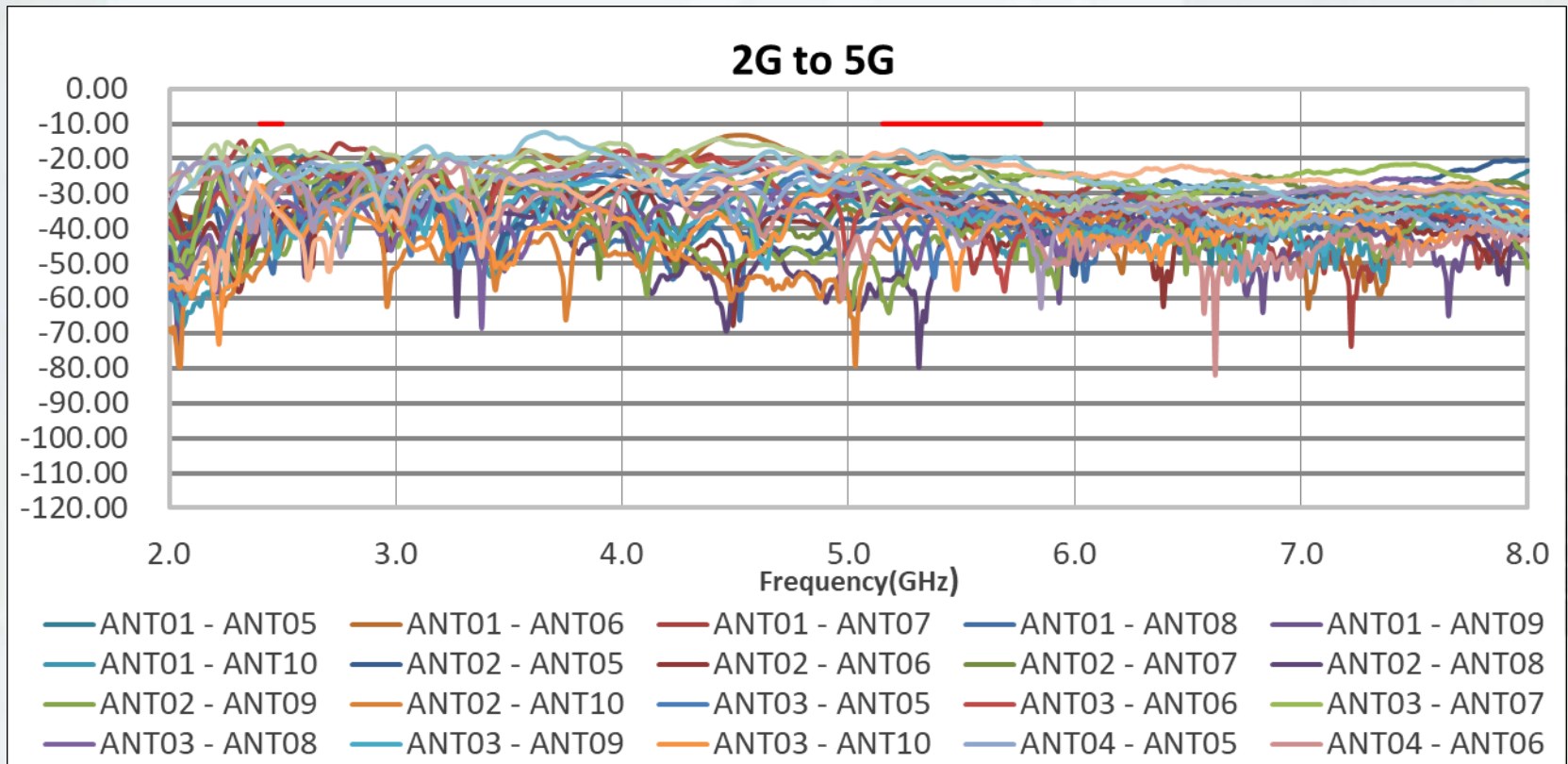

Isolation Results

2G to 6G

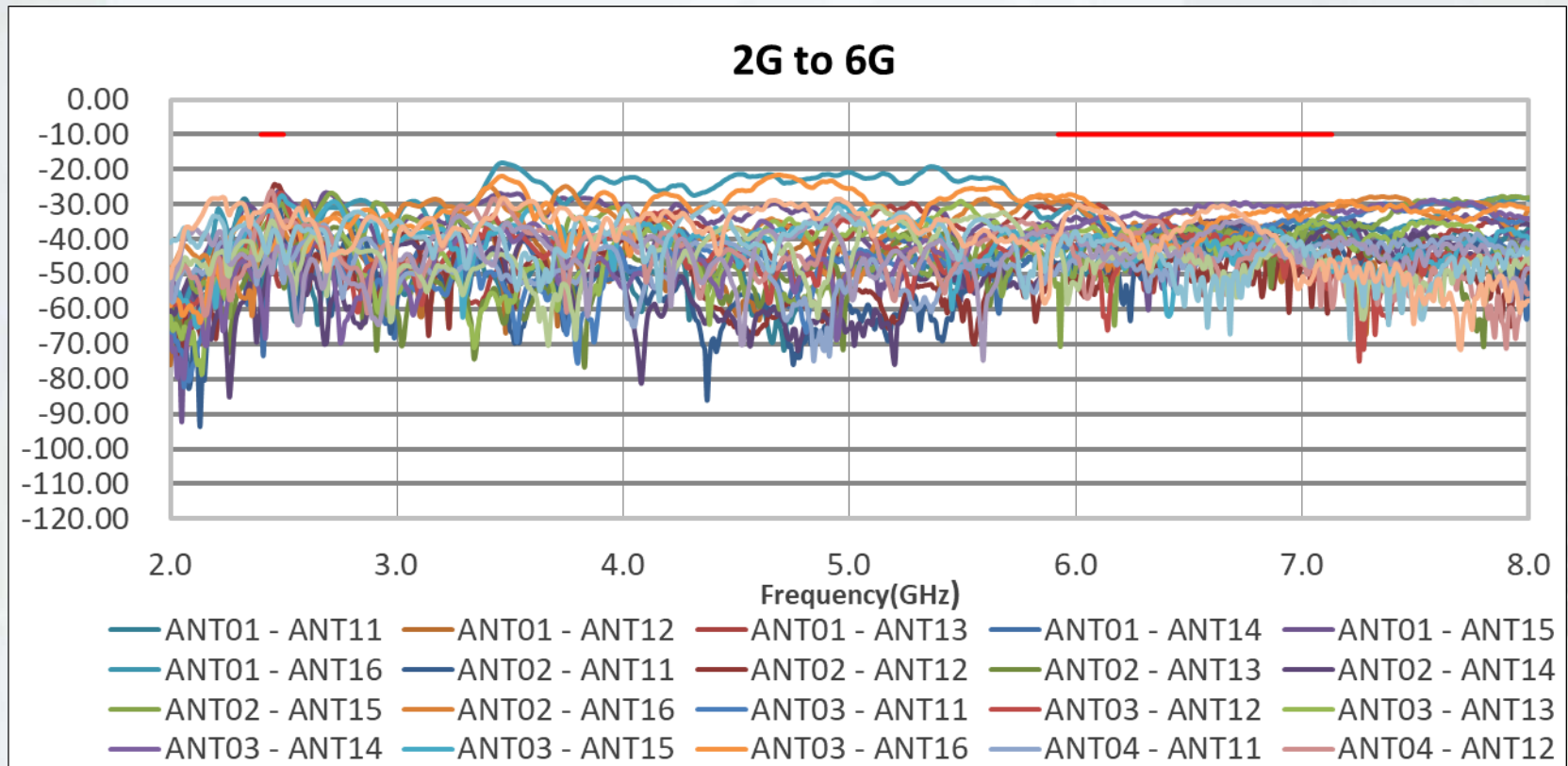

Isolation Results

5G to 6G(5)

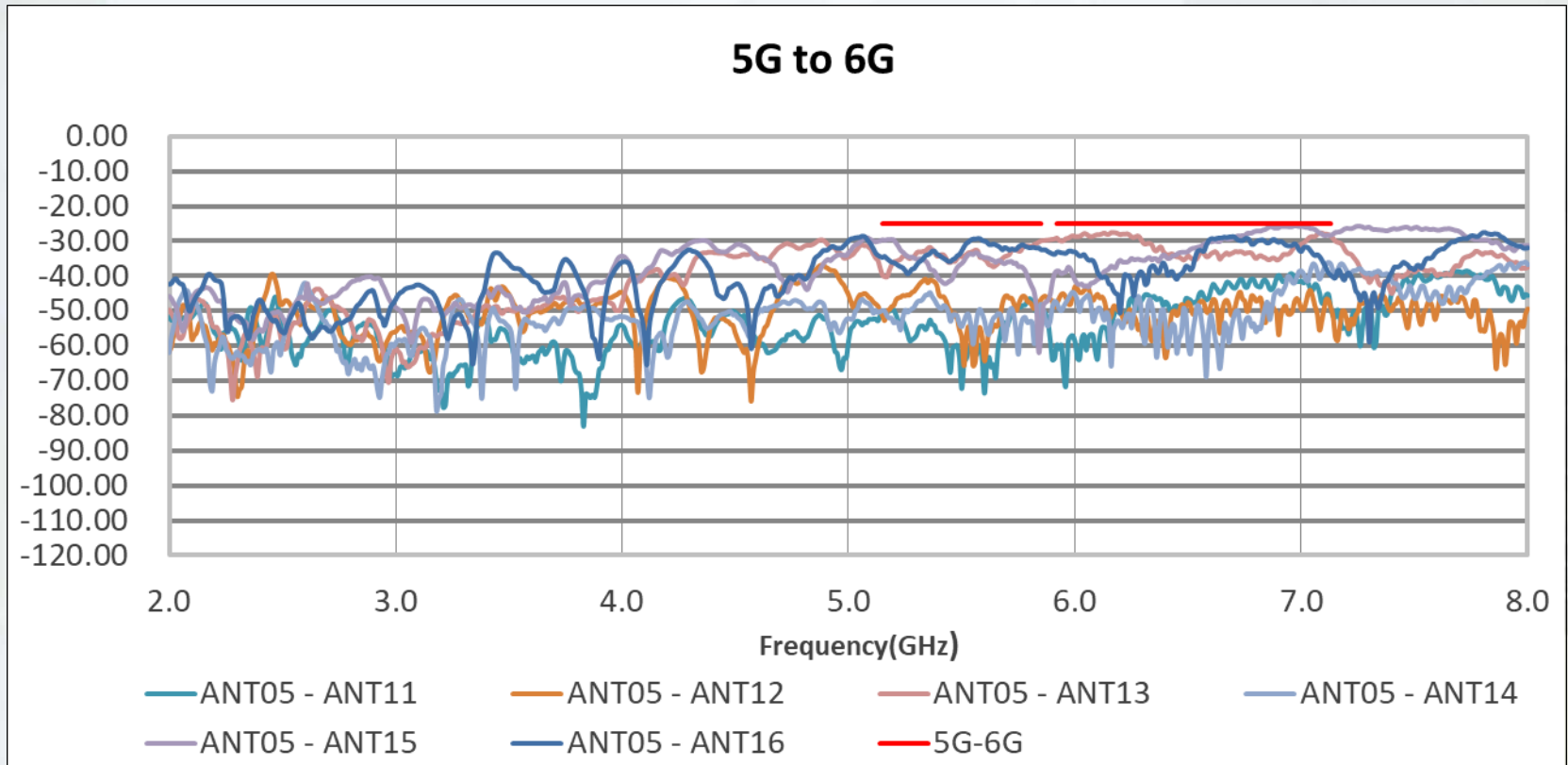

Isolation Results

5G to 6G(6)

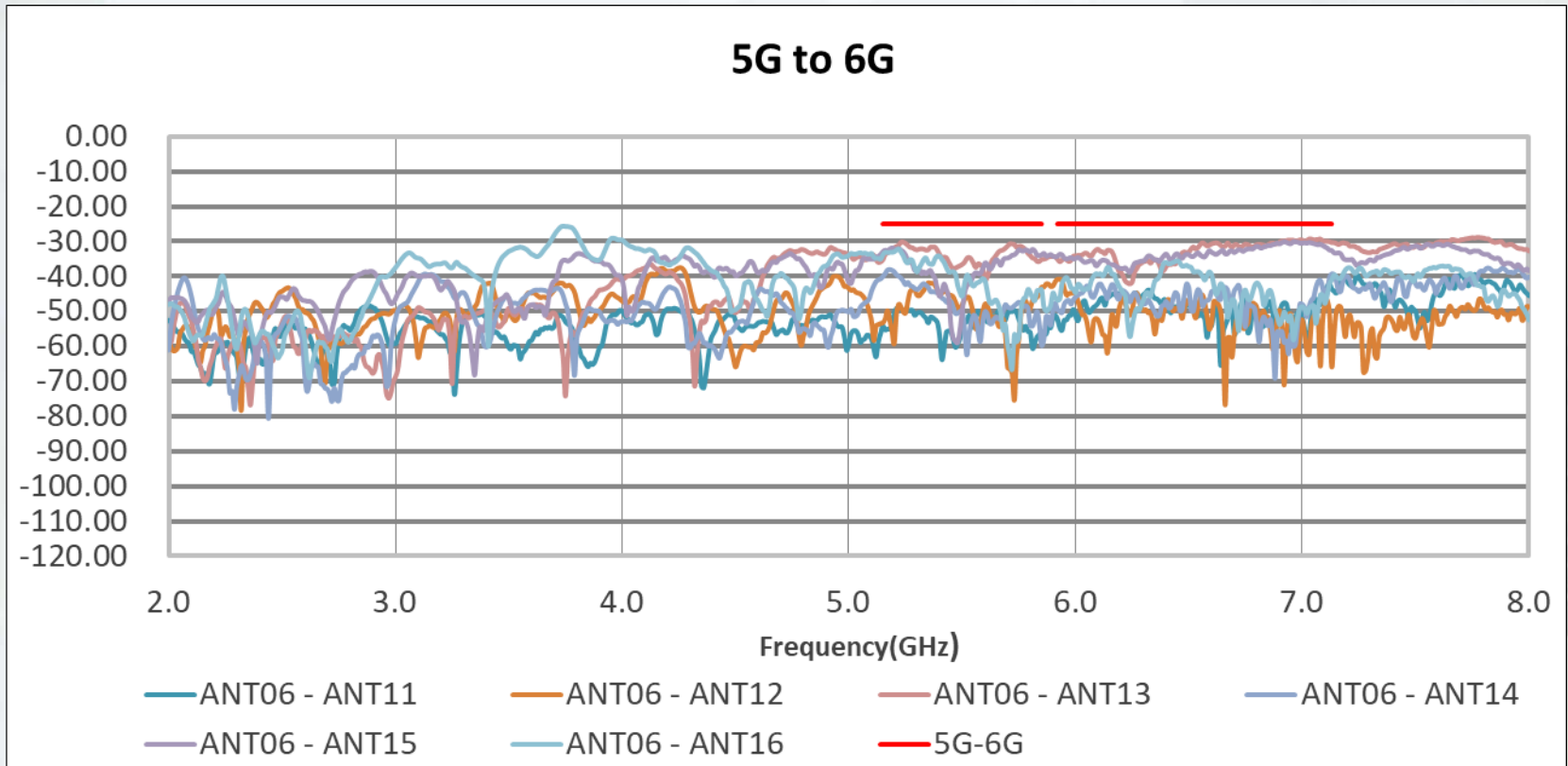

Isolation Results

5G to 6G(7)

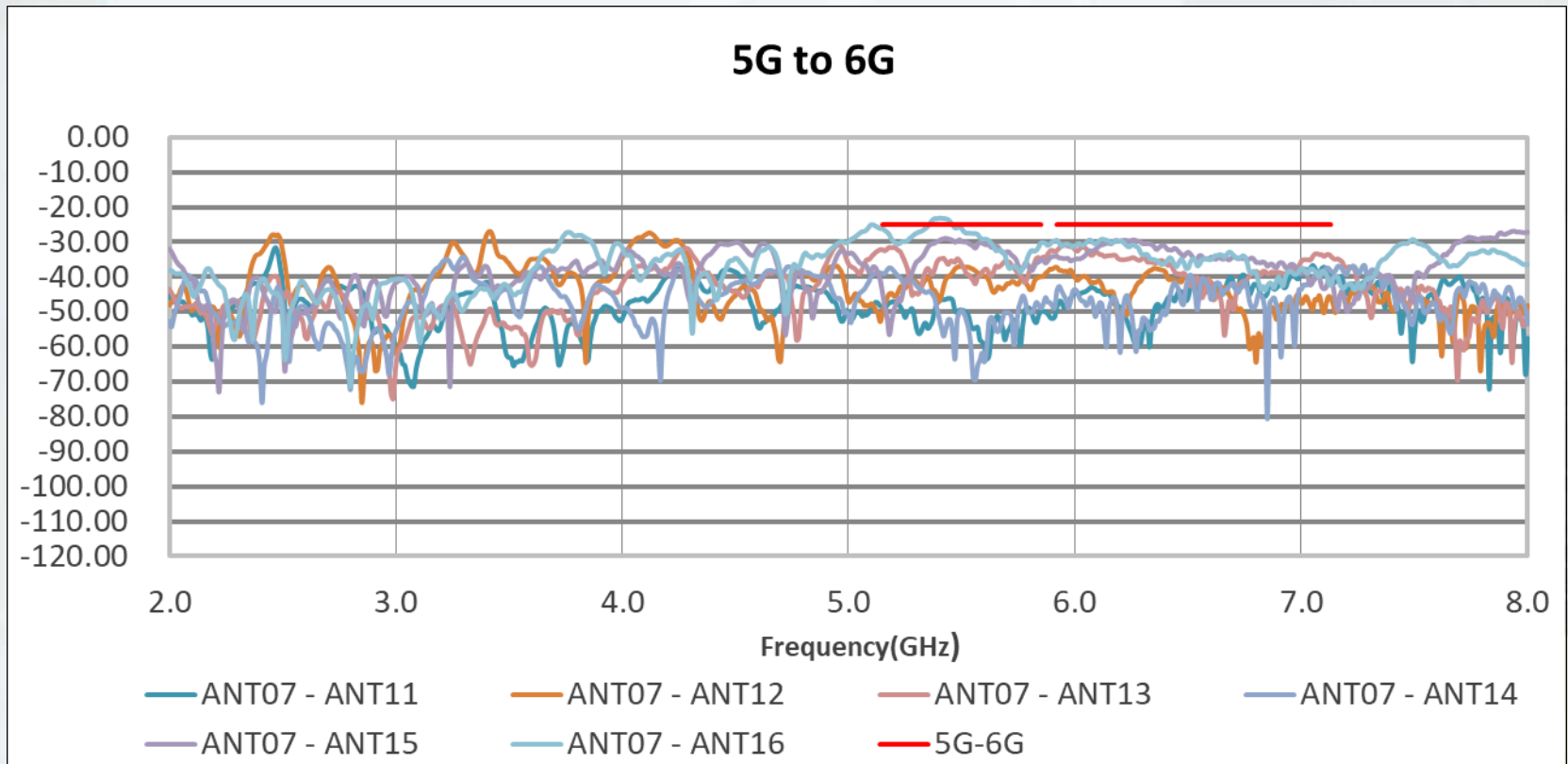

Isolation Results

5G to 6G(8)

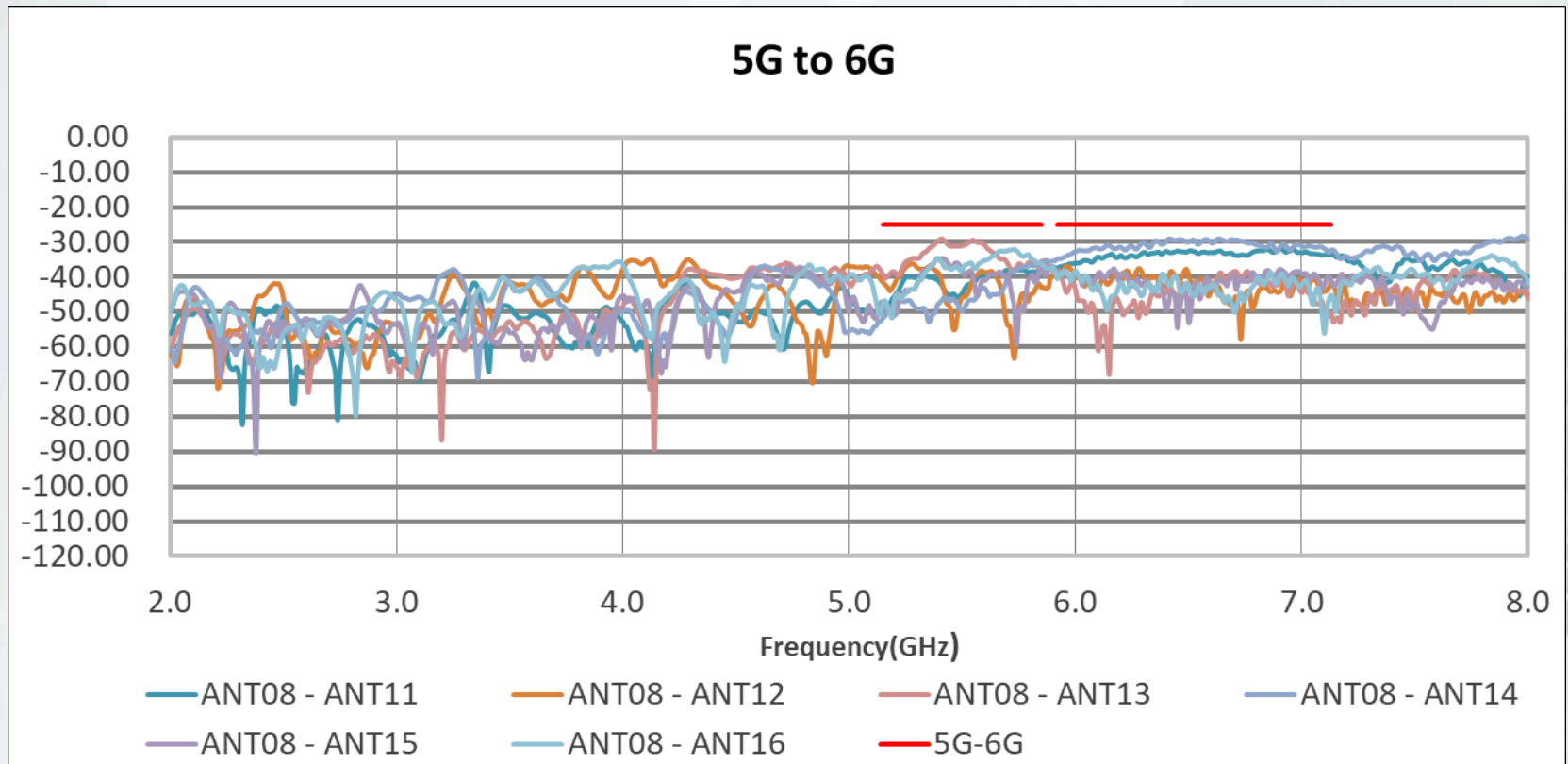

Isolation Results

5G to 6G(9)

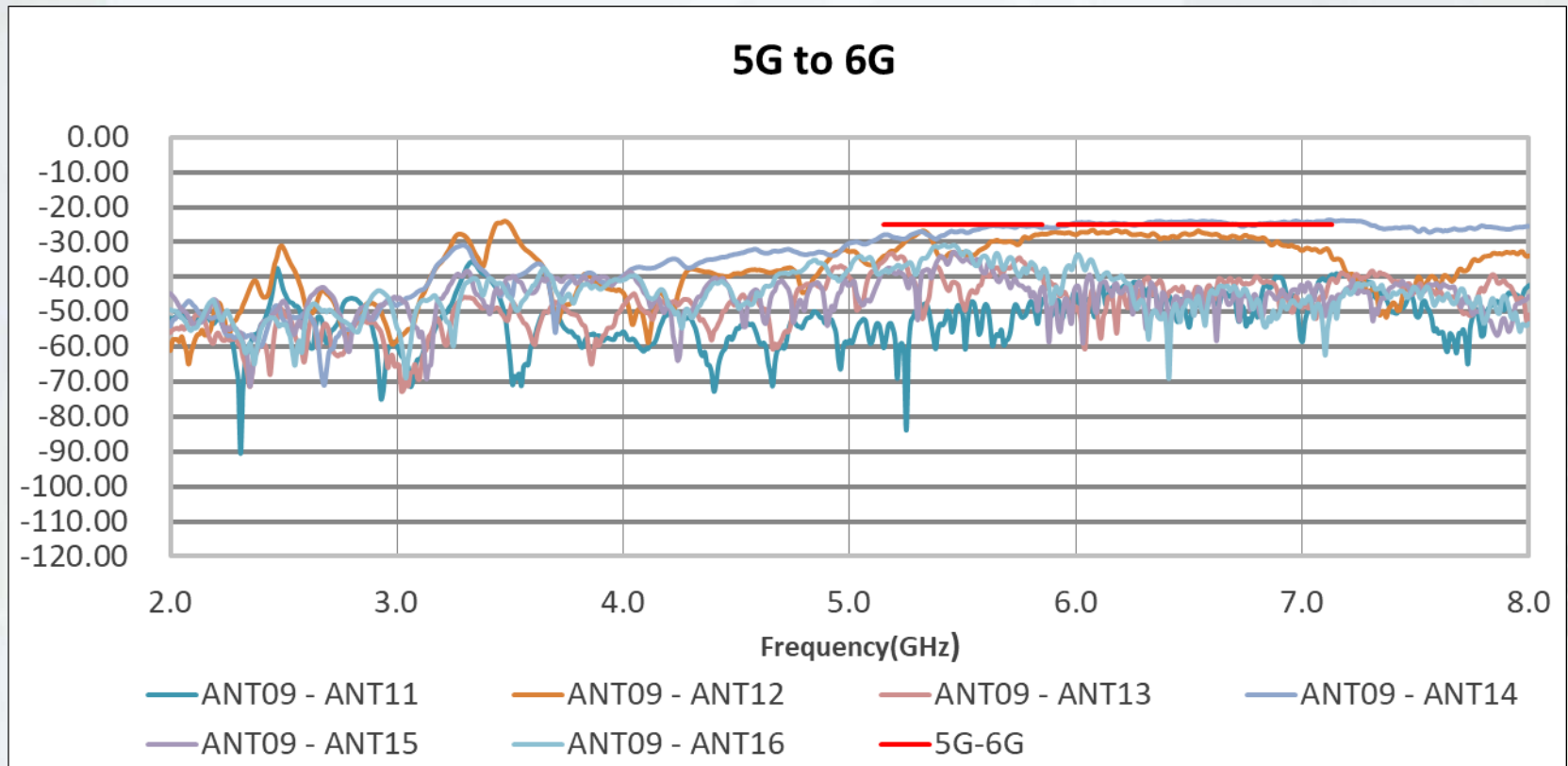

Isolation Results

5G to 6G(10)

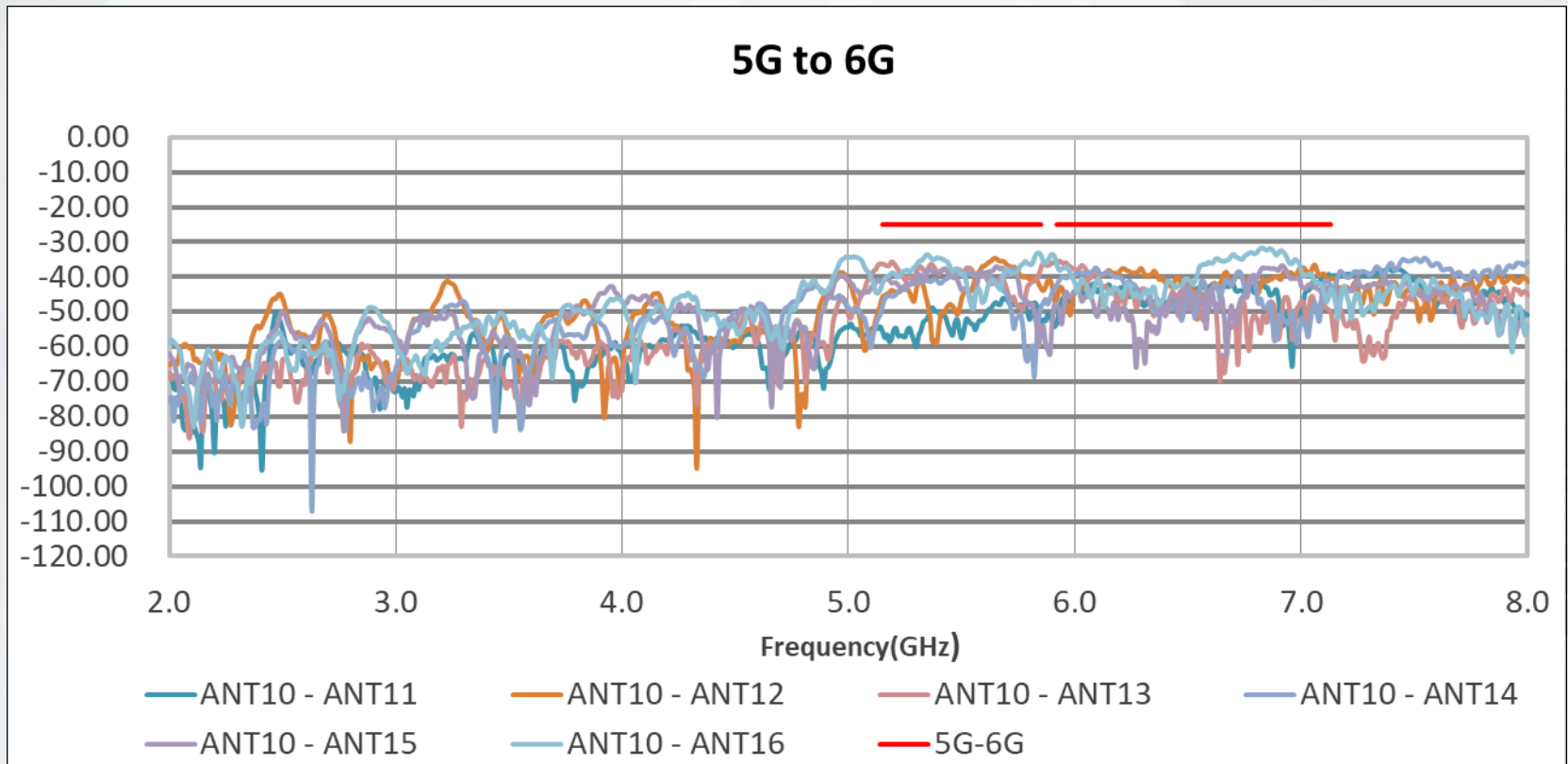

Test Setup for Radiation Pattern Measurement

Chamber Information

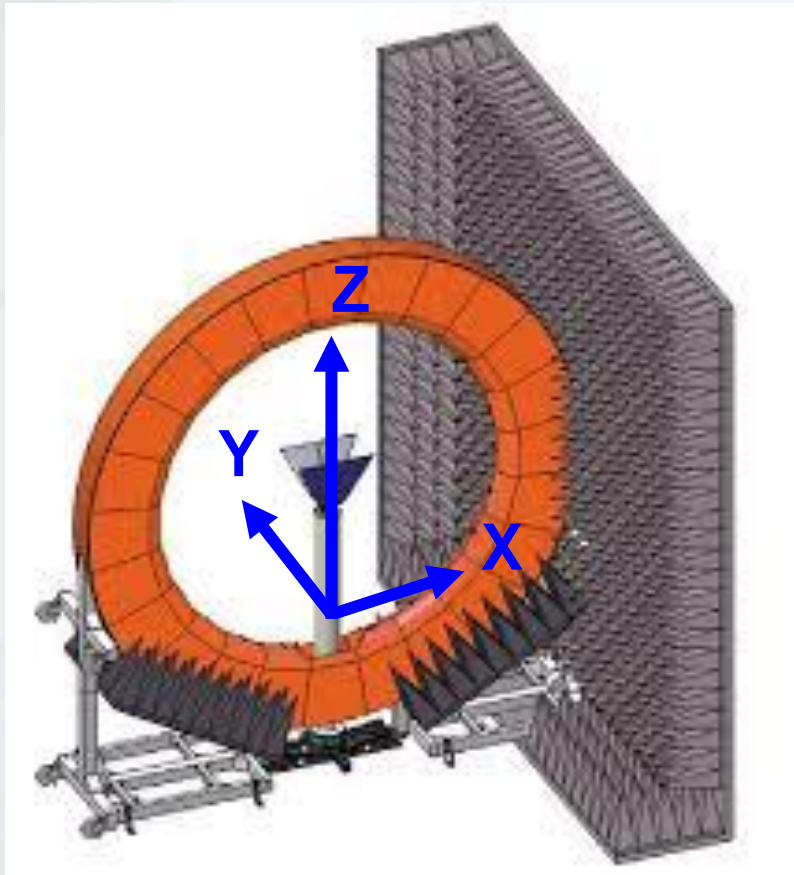

- **SATIMO SG-24L Multi-Probe Antenna Measurement System**

- Angle between probes: 15°
- Frequency range: 400 MHz – 8.5 GHz
- Chamber Room Size: 5m L x 5m W x 5m H

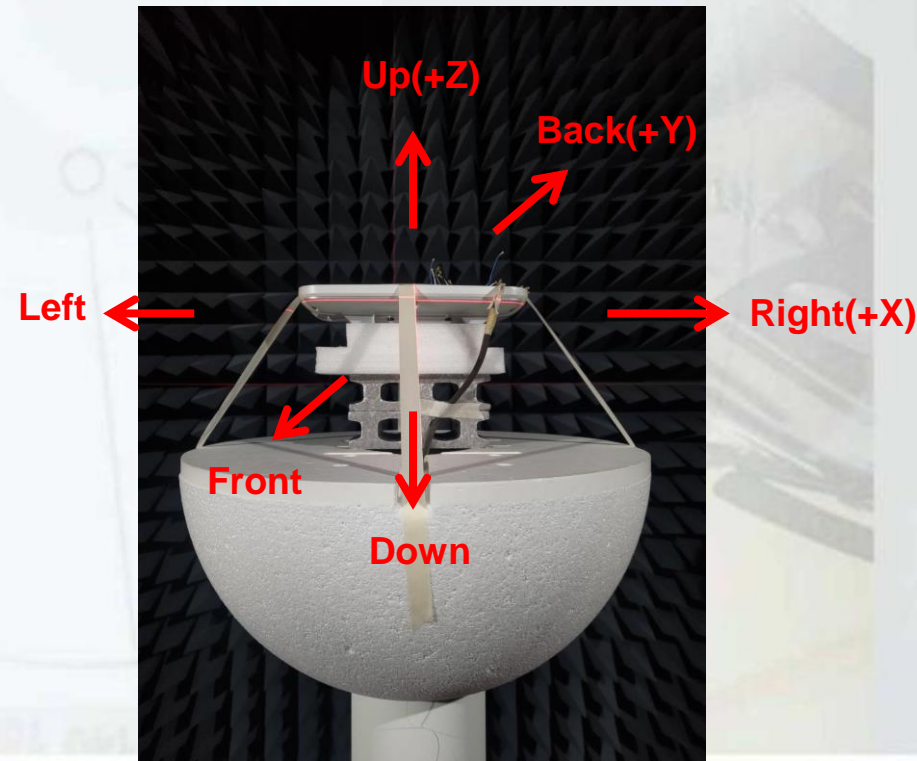

2D Radiation Pattern Results

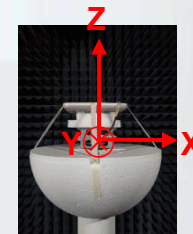

Ant 1

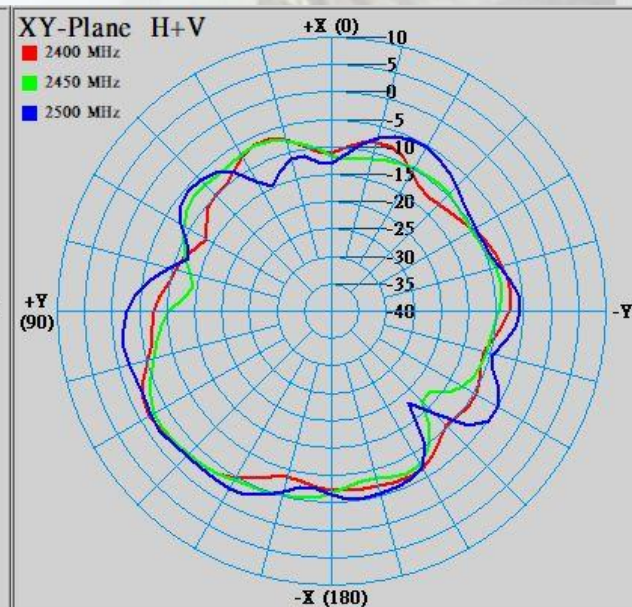
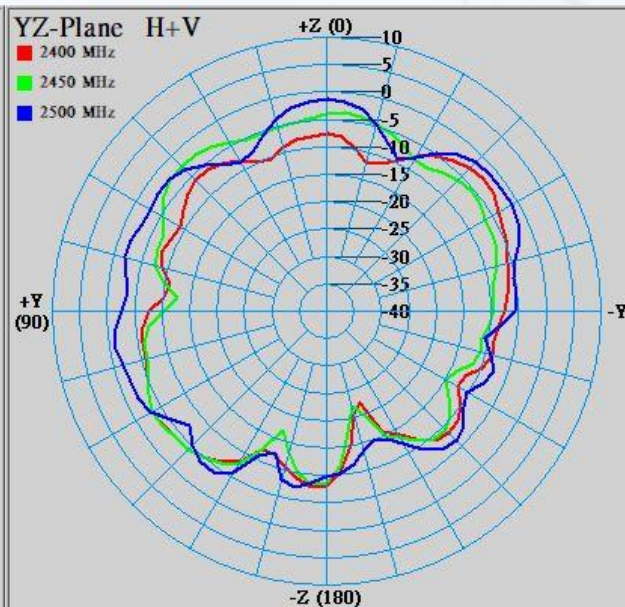
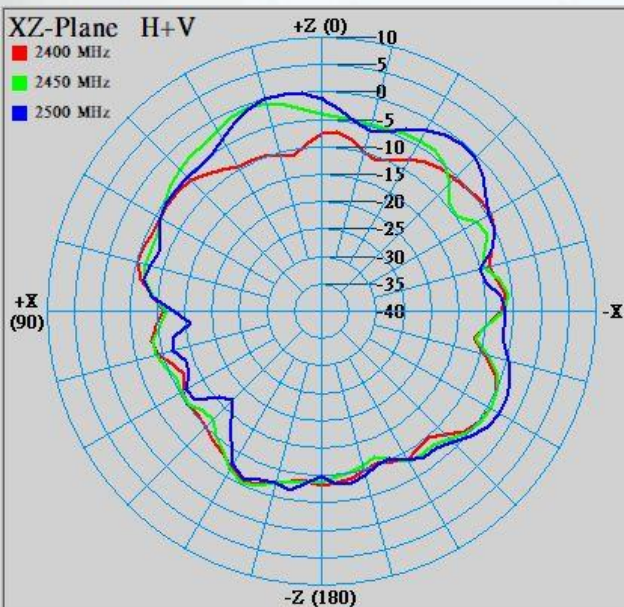
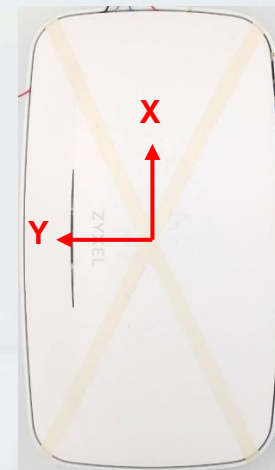
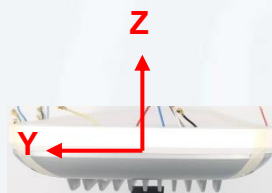
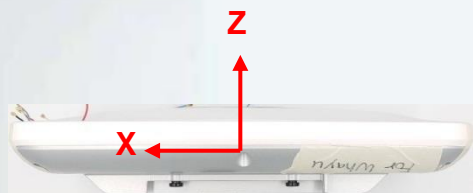

2D Radiation Pattern Results

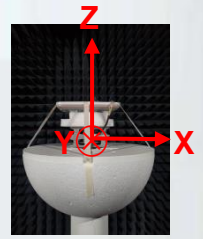

Ant 2

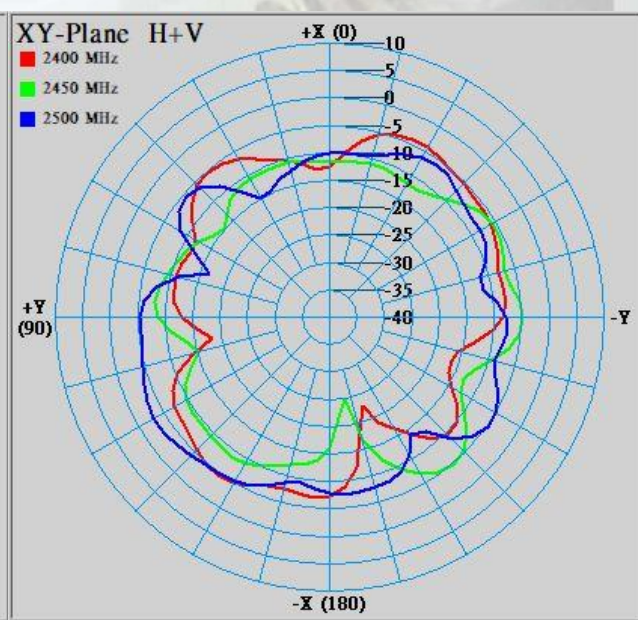
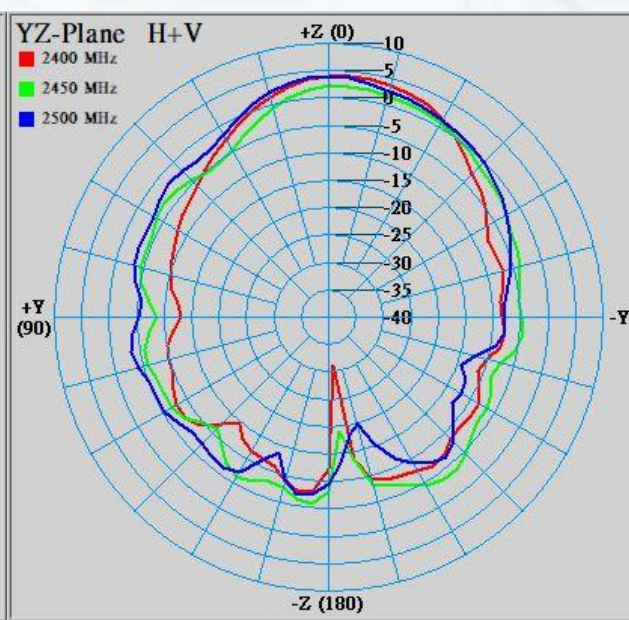
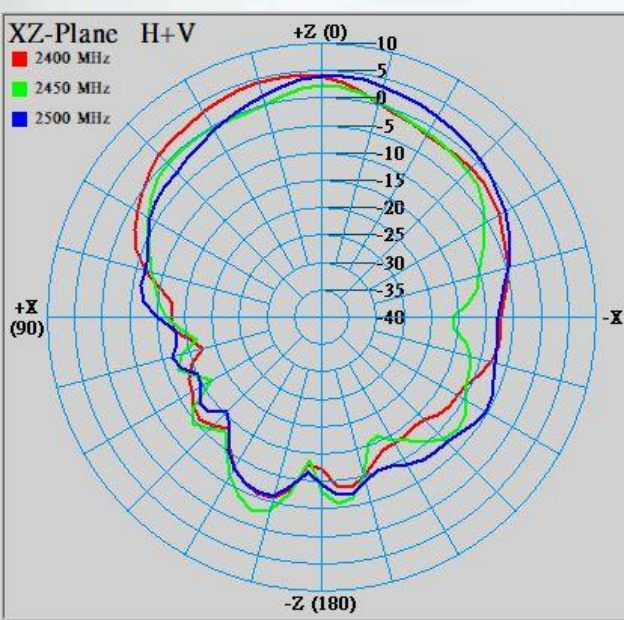
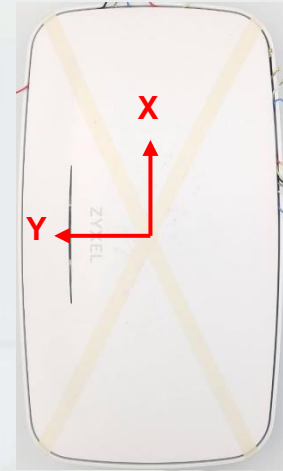
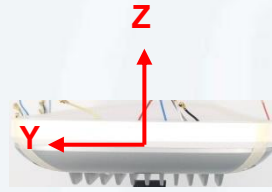
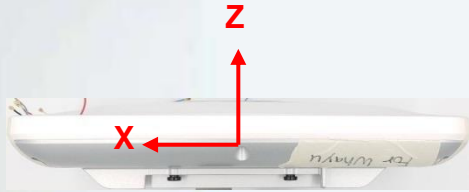

2D Radiation Pattern Results

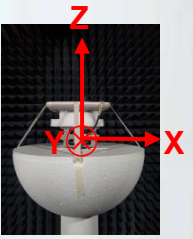

Ant 3

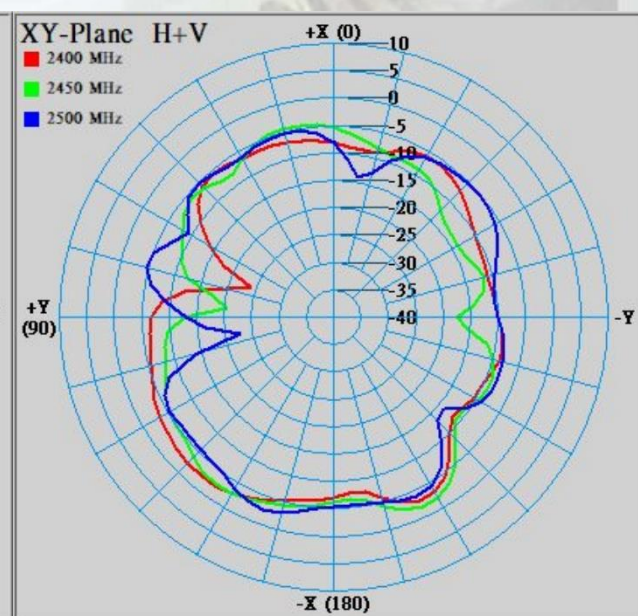
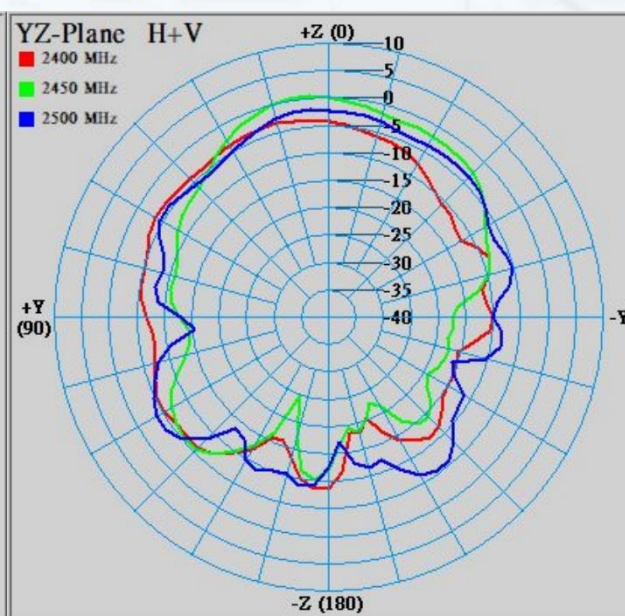
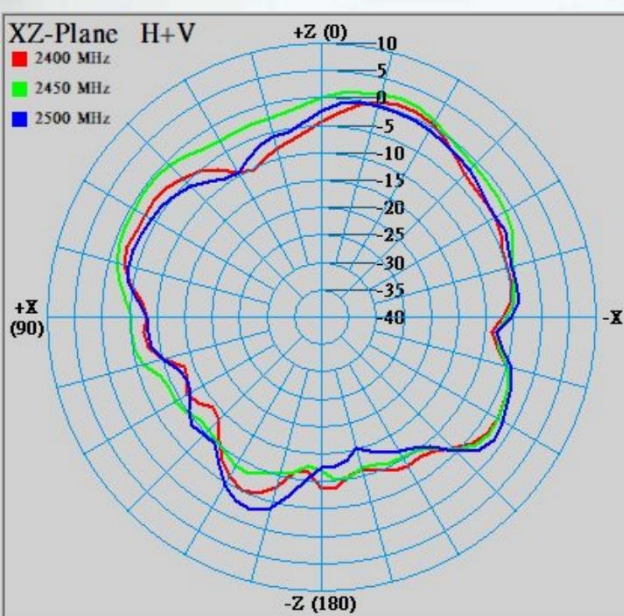
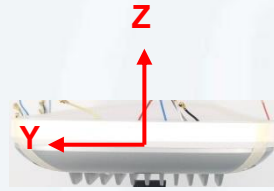
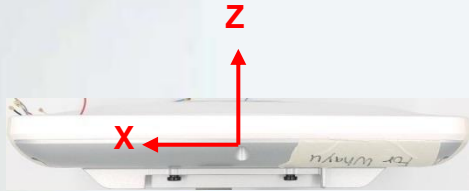

2D Radiation Pattern Results

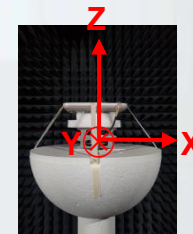

Ant 4

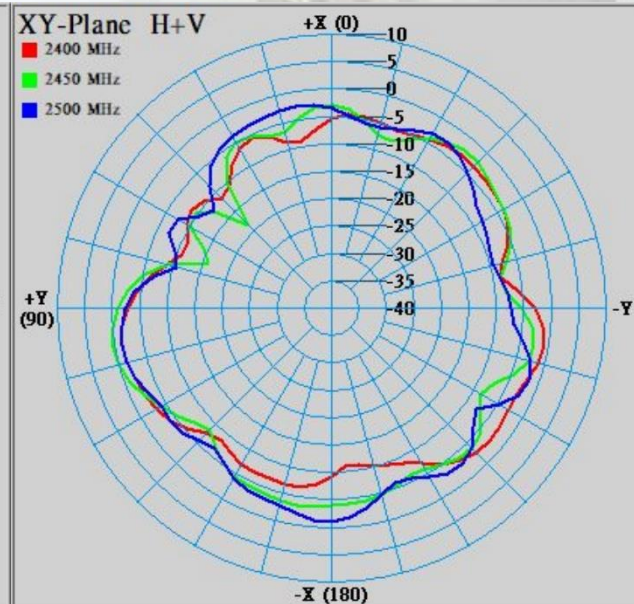
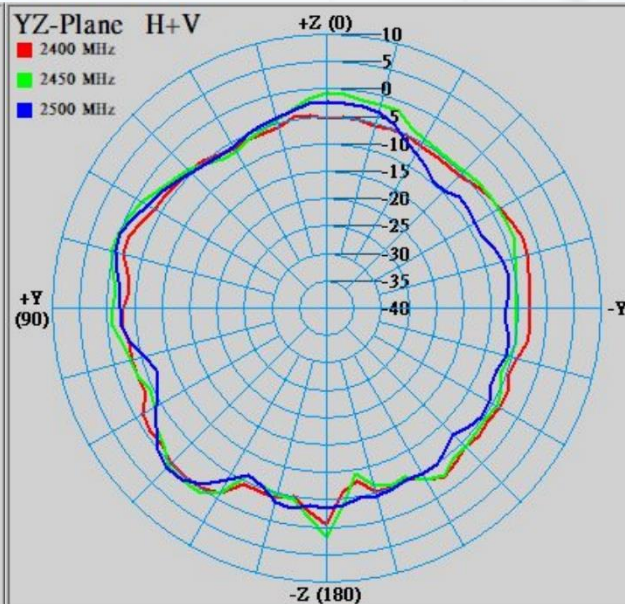
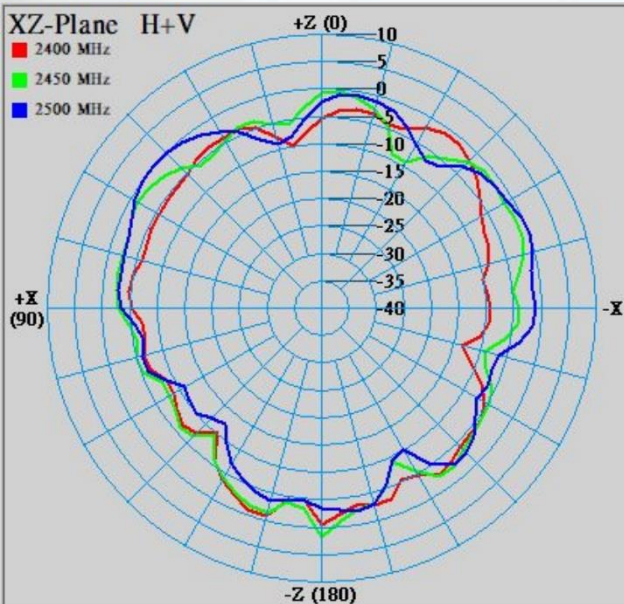
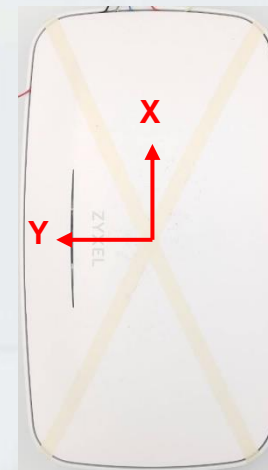
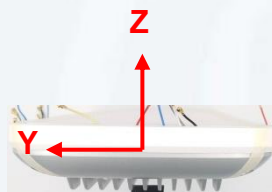
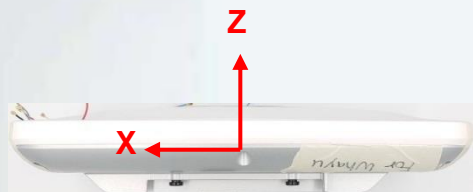

2D Radiation Pattern Results

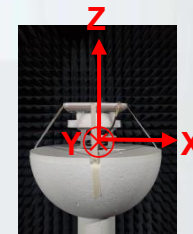

Ant 5

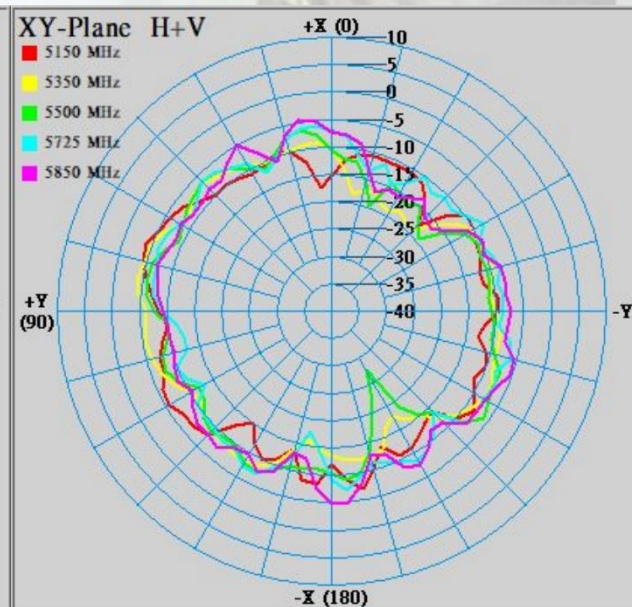
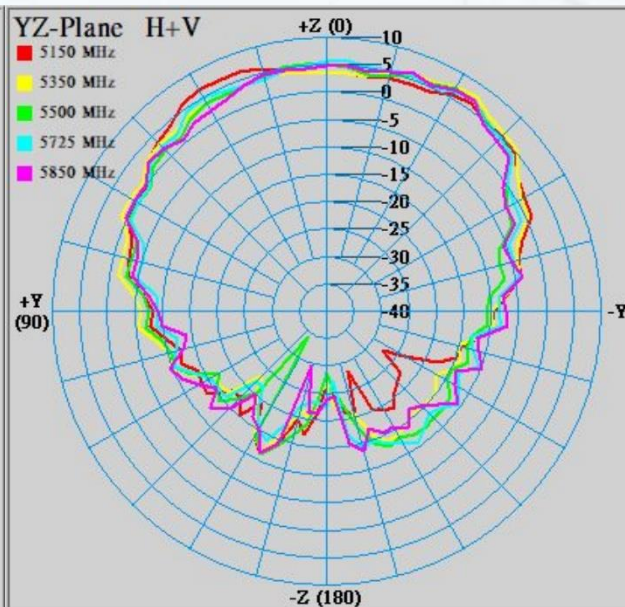
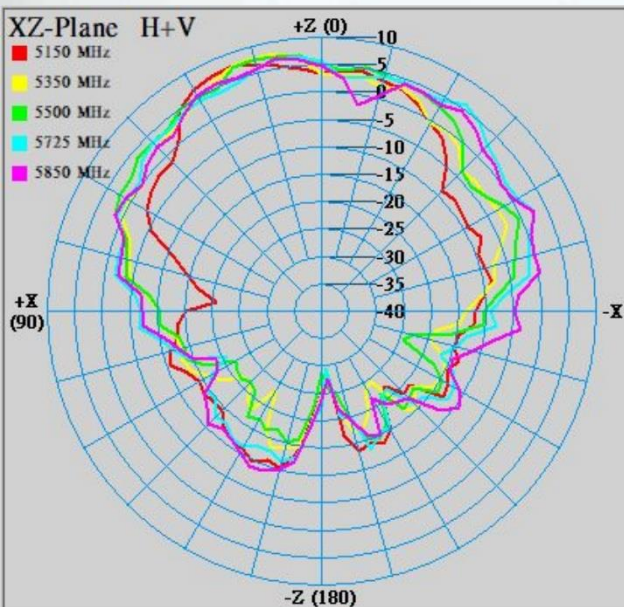
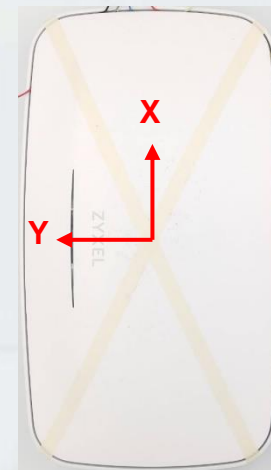
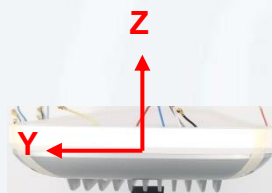
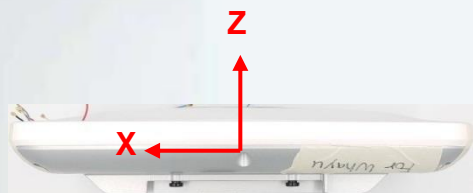

2D Radiation Pattern Results

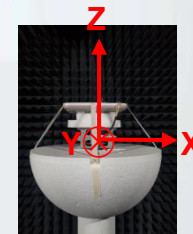

Ant 6

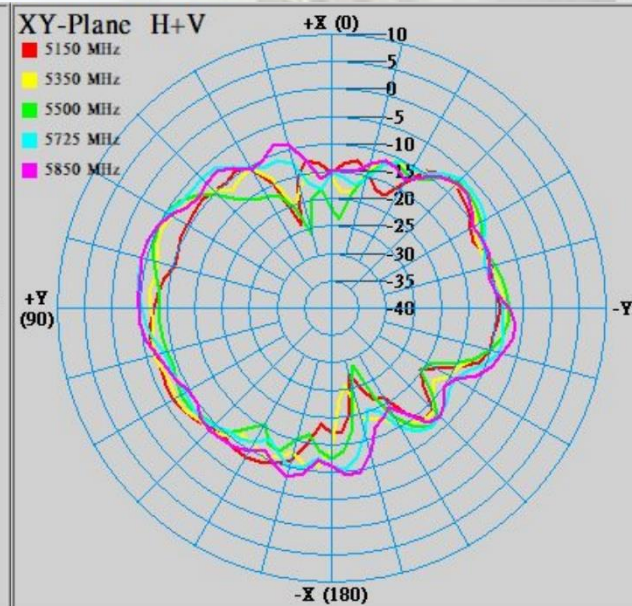
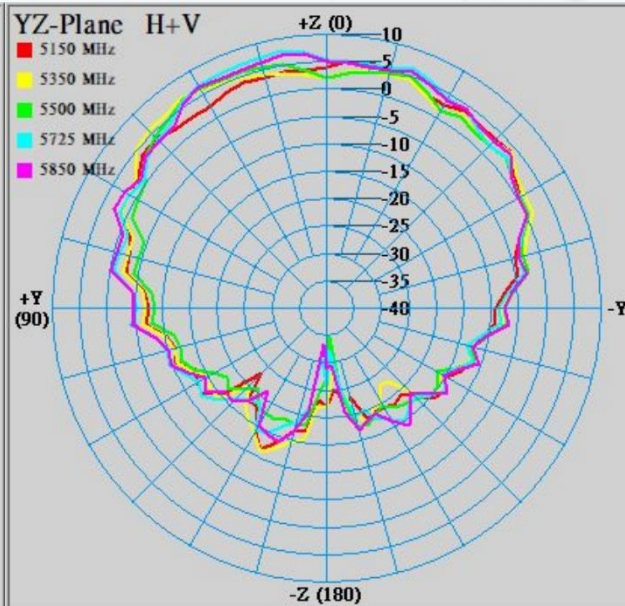
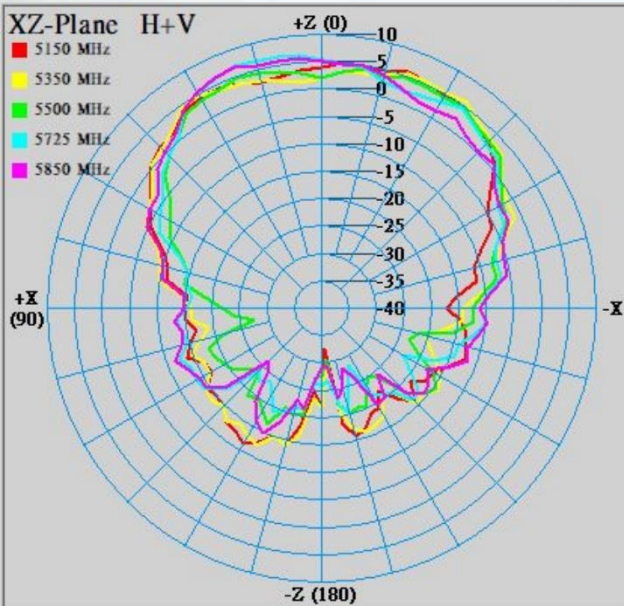
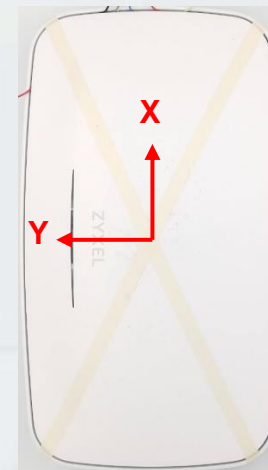
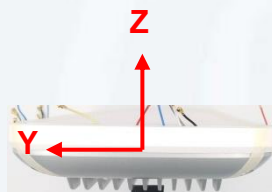
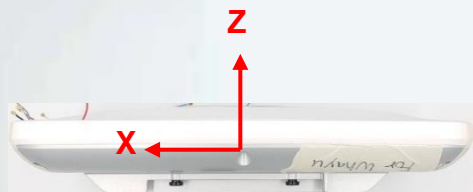

2D Radiation Pattern Results

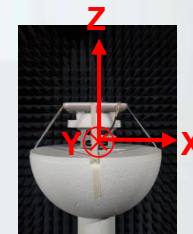

Ant 7

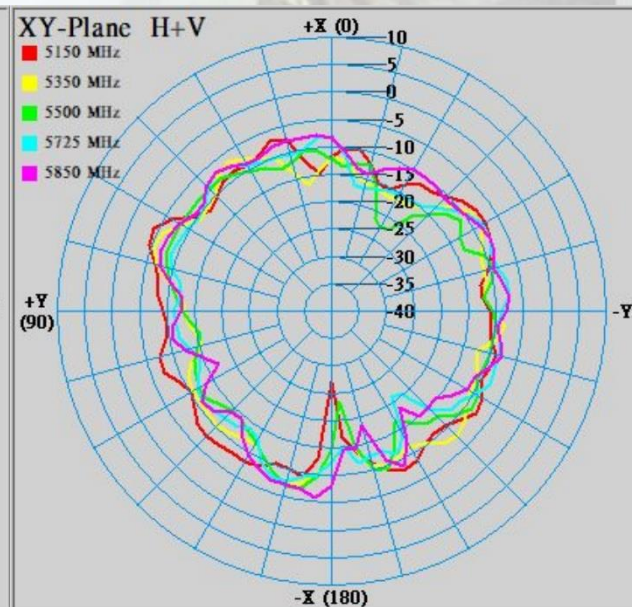
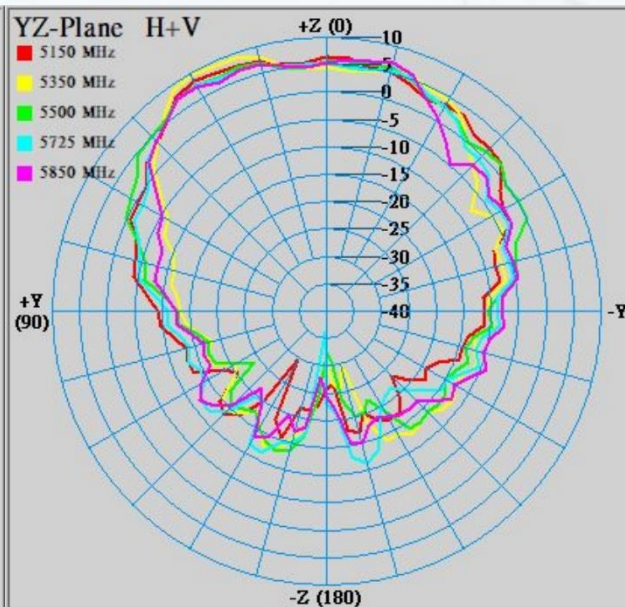
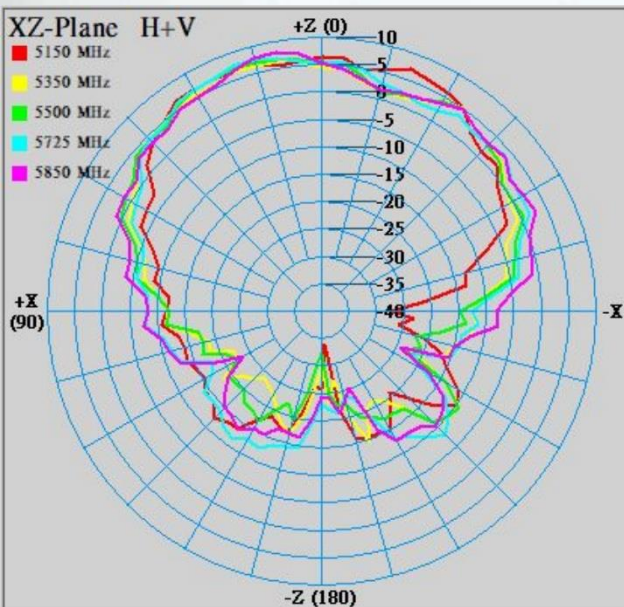
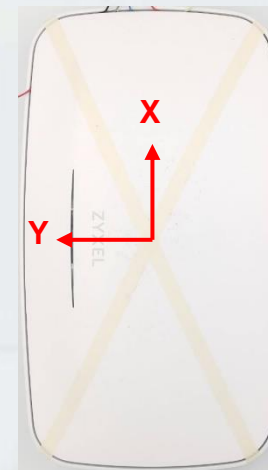
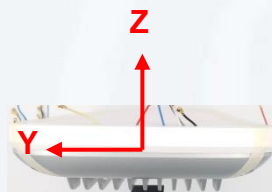
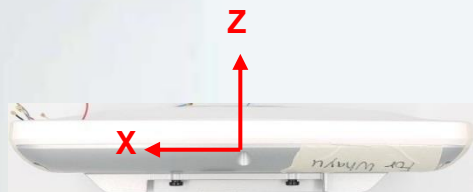

2D Radiation Pattern Results

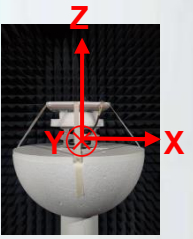

Ant 8

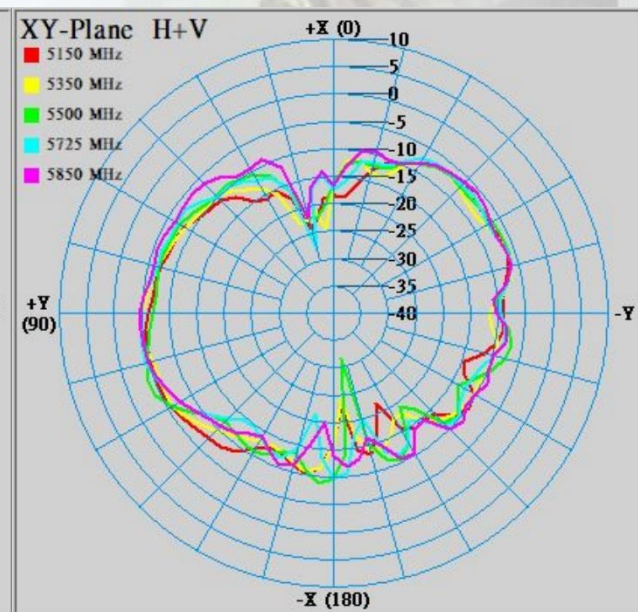
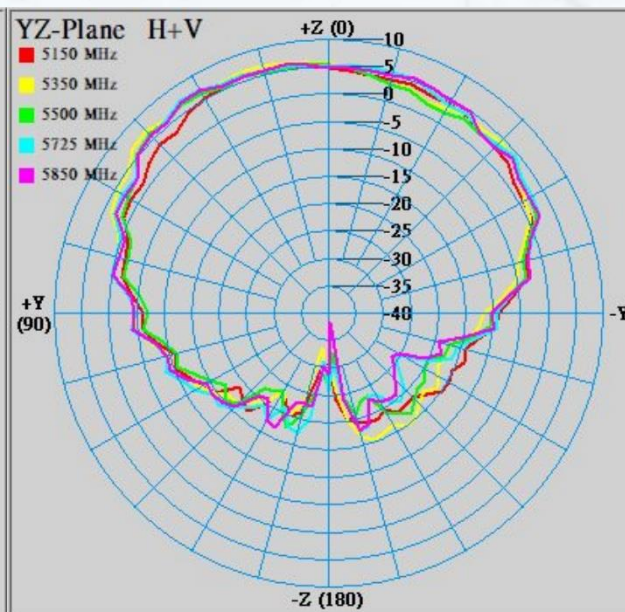
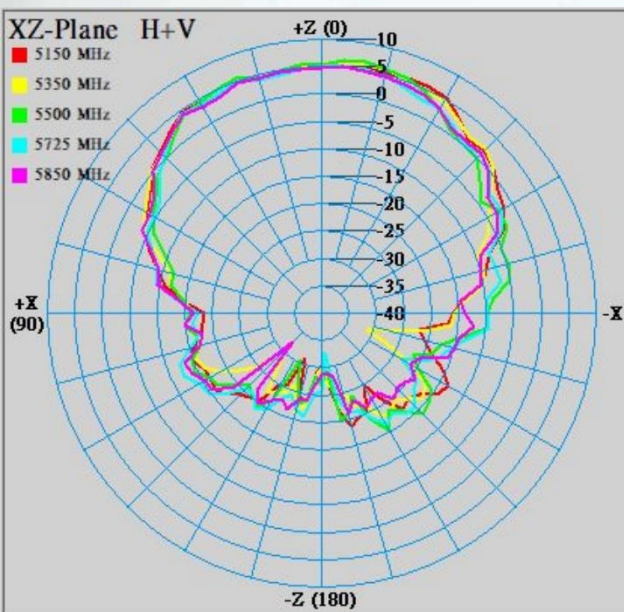
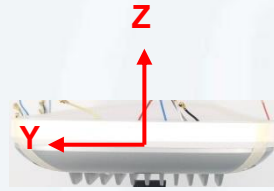
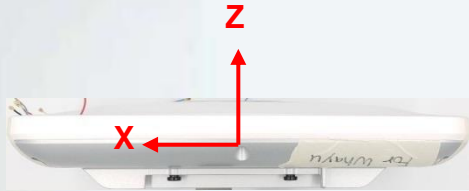

2D Radiation Pattern Results

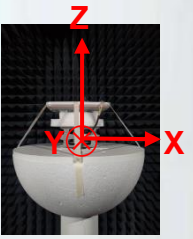

Ant 9

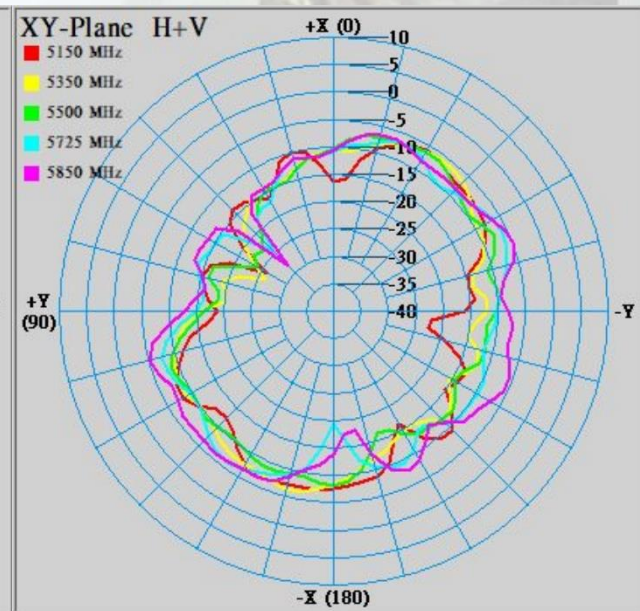
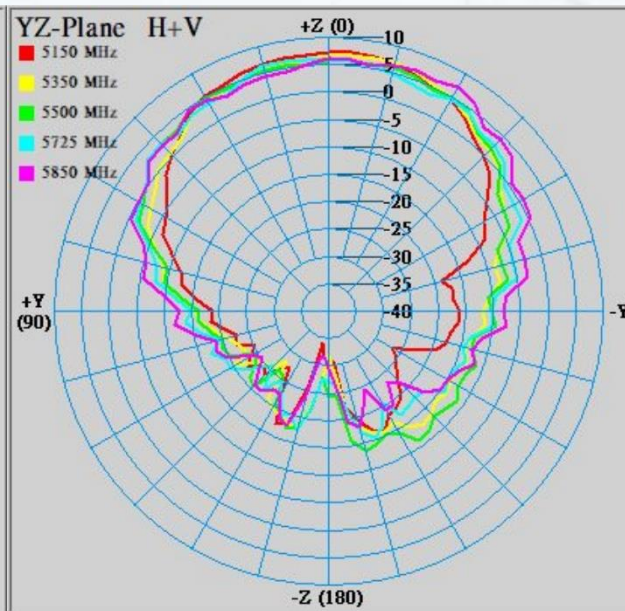
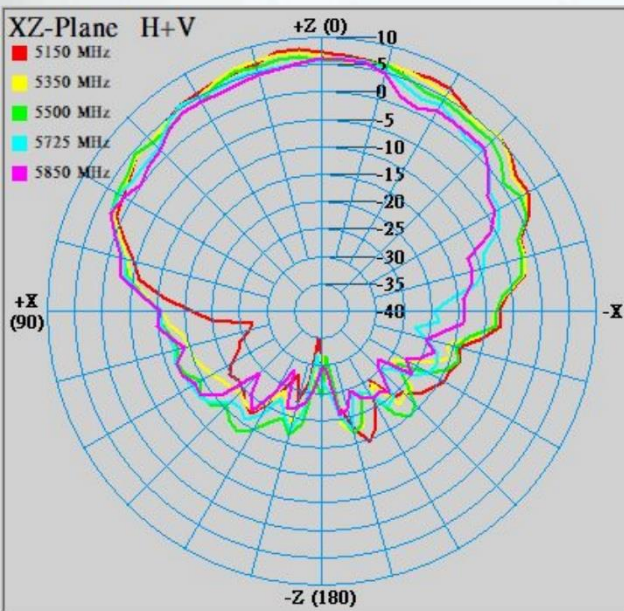
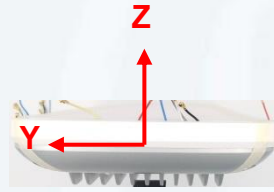
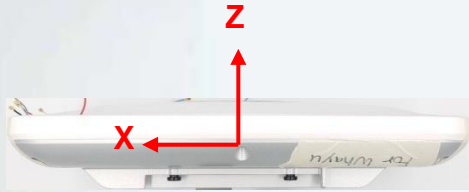

2D Radiation Pattern Results

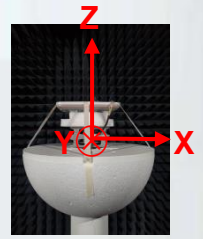

Ant 10

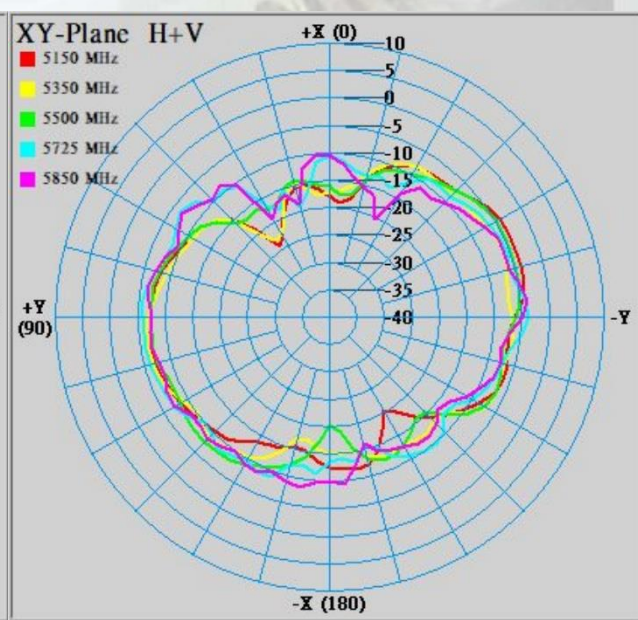
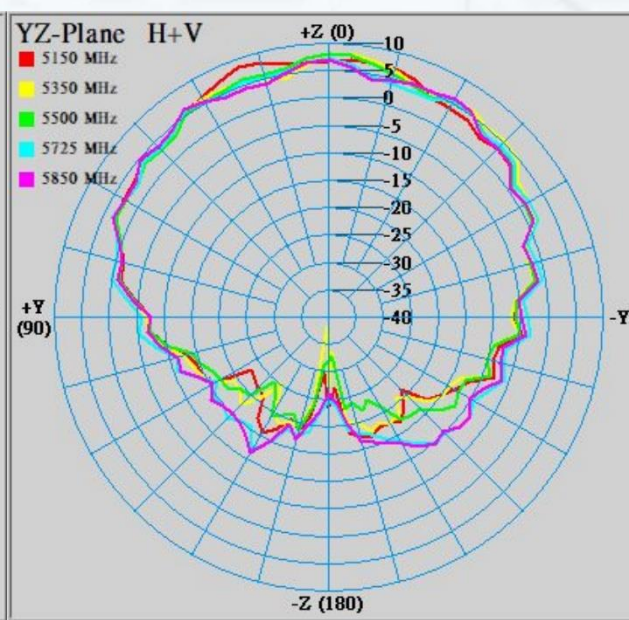
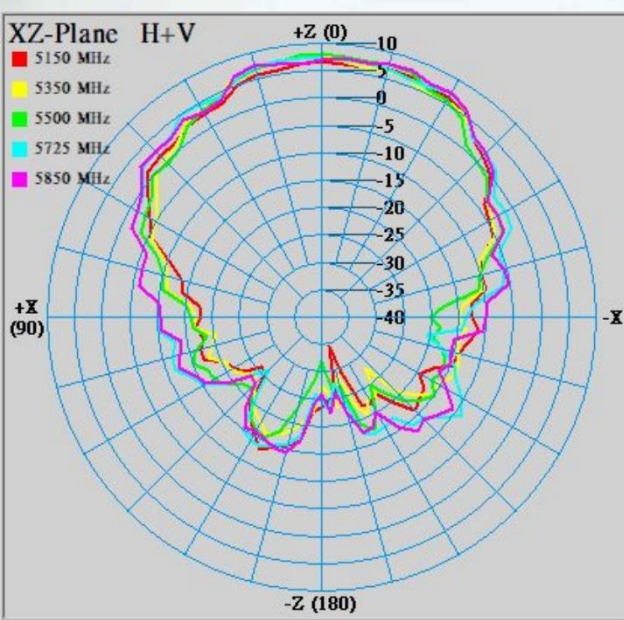
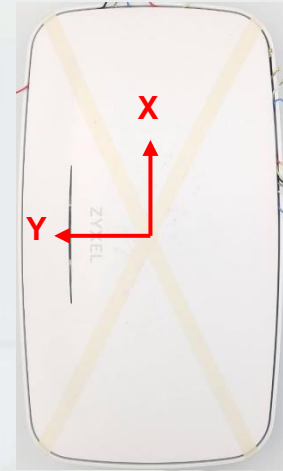
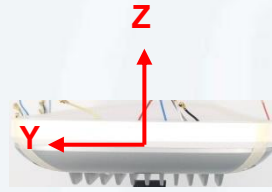
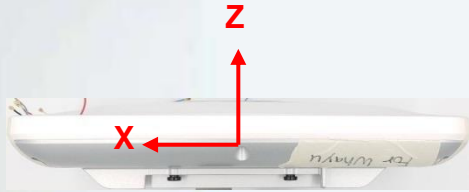

2D Radiation Pattern Results

Ant 11

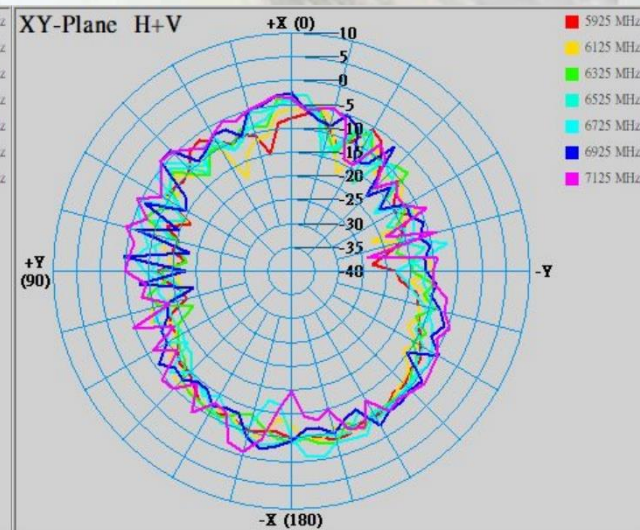
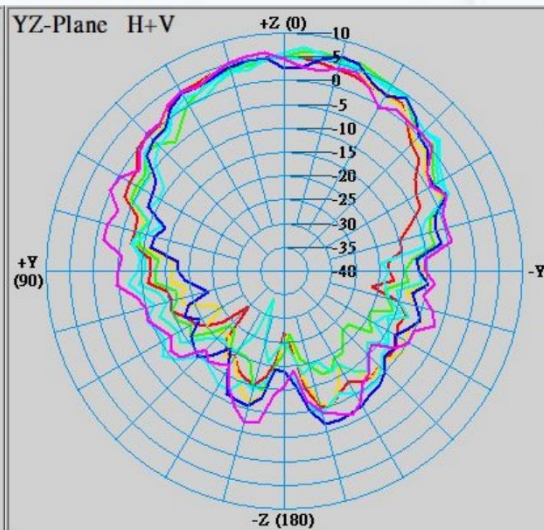
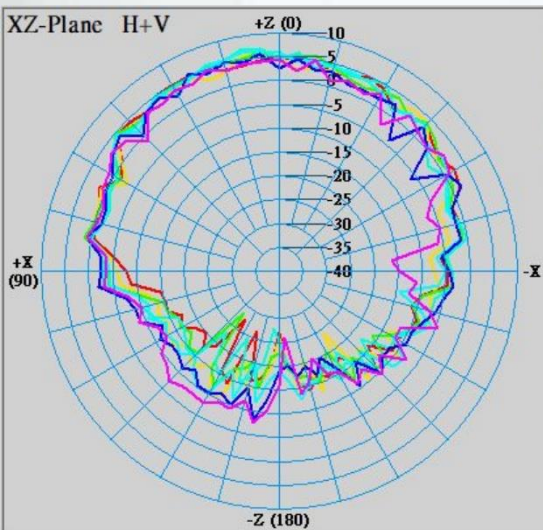
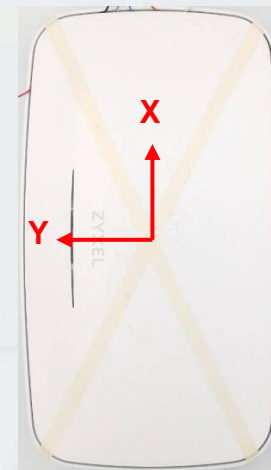
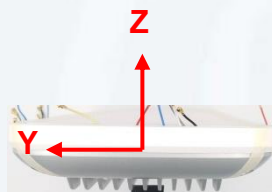
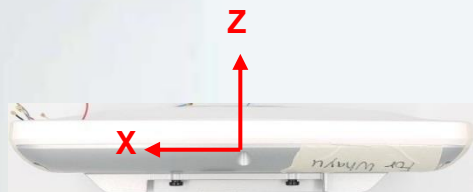
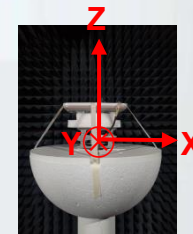

2D Radiation Pattern Results

Ant 12

