

PROPRIETARY AND CONFIDENTIAL

THE INFORMATION CONTAINED IN THIS DRAWING IS THE SOLE PROPERTY OF GTO ACCESS SYSTEMS, LLC. ANY REPRODUCTION IN PART OR AS A WHOLE WITHOUT WRITTEN PERMISSION OF GTO ACCESS SYSTEMS, LLC IS PROHIBITED.

REV.	DESCRIPTION	DATE	APPROVED
A	RELEASE PER ECO-022147	07/10/17	

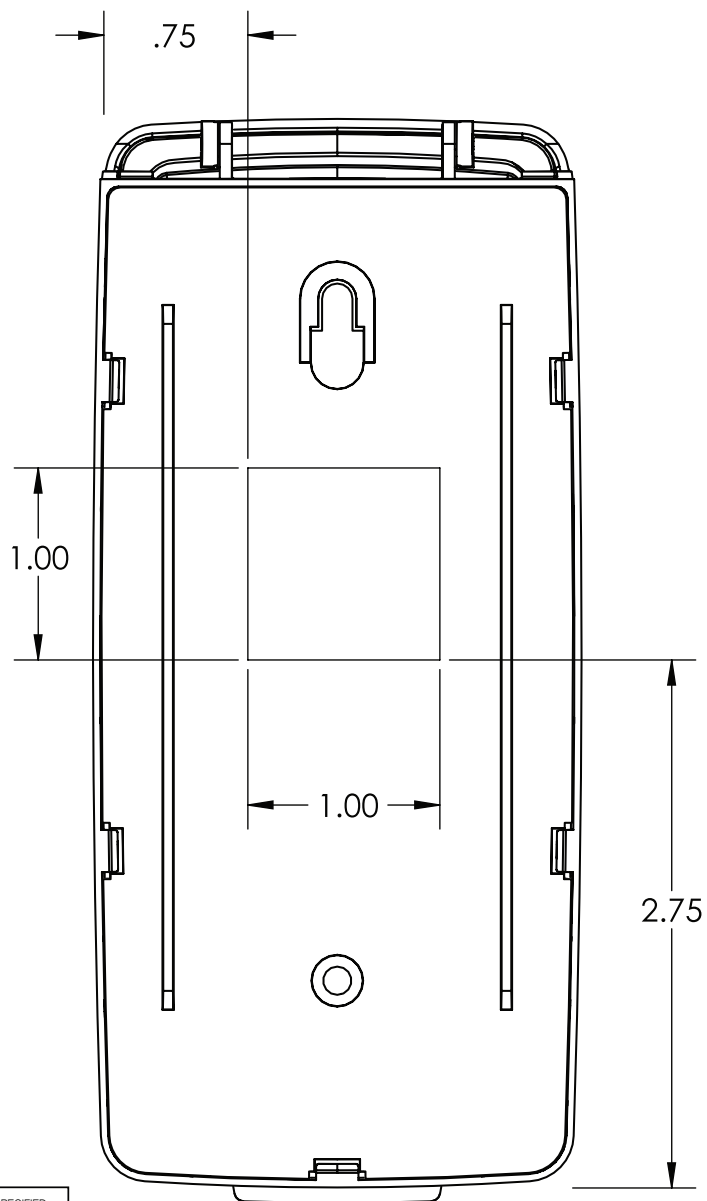

FCC ID: 16H-MMK100

IC: 21449-MMK100

This device complies with FCC rules Part 15. Operation is subject to the following two conditions: (1) This device may not cause harmful interference and (2) this device must accept any interference received, including interference that may cause undesired operation.

GTO ACCESS SYSTEMS, LLC
DIGITAL TRANSMITTER
MODEL: MMK100 **FREQ: 318 MHz**
MADE IN CHINA 10017085

LABEL,FCC/DOC,MMK100
 GTO P/N: 10017085
 MFG. PROCESS: PRINTED LABEL OR PAD PRINTING
 LABEL INK: PERMANENT WHITE
 LABEL MATERIAL: CLEAR ACETATE, ADHESIVE BACKED
 THICKNESS: .0015"
 PAD PRINTING INK: WHITE (MAXCIM P/N 213337-001)
 SCALE: 1-1

UNLESS OTHERWISE SPECIFIED:
 WHEN DIMENSIONS ARE IN INCHES TOLERANCES:
 FRACTIONAL ±1/16
 ANGULAR: ± 2°
 .XX = ±.01
 .XXX = ±.005

WHEN DIMENSIONS ARE IN mm TOLERANCES:
 ANGULAR: ± 2°
 Xmm = ±1mm
 XXmm = ±.5mm
 XXXmm = ±.15mm

MATERIAL:	DRAWN:	 3121 HARTSFIELD ROAD TALLAHASSEE, FL 32303
INK:	CHECKED:	
NOTES:	ENG APPR:	
	MFG APPR:	
	Q.A.	TITLE: LABEL, FCC/DOC, MMK100
		SIZE: A DRAWING/PART NUMBER: 10017085 REV: A
		SCALE: 1:1 WEIGHT: SHEET 1 OF 1