



TRUCK PACKAGE FOR CHANNELMASTER TX1 ~ PS18 Control Drawer and High Power Amplifier(s) ~



User Manual

NUCOMM PUBLICATION: M03-0008-00A – REV 0.1

Nucomm Inc.
101 Bilby Road
Hackettstown, NJ 07840
Tel: 908-852-3700 Fax: 908-813-0399
www.Nucomm.com

CAUTION!

RISK OF ELECTRICAL SHOCK. DO NOT REMOVE COVERS.

- Do not remove any covers.
- Refer servicing to qualified technicians only.
 - Disconnect all power before servicing.
 - Read and perform all instructions carefully.
- Failure to follow suggested instructions and guidelines may void all warranties.

FCC STATEMENT

This equipment has been tested and found to comply with Part 74.637 (a) (2) of the FCC Rules and Regulations. Any unauthorized changes or modifications not expressly approved by Nucomm, Inc. could void the user's authority to operate the equipment, and invalidate the equipment's warranty.

RF Exposure Warning

This equipment complies with FCC radiation exposure limits set forth for an uncontrolled environment.

End users must follow the specific operating instructions for satisfying RF exposure compliance.

The antenna(s) used for this transmitter must be installed to provide a separation distance of at least 20 cm from all persons, and must not be co-located or operating in conjunction with any other antenna or transmitter.

Document Revision

Date Modified	Revision	Modified by	Modification Detail
March 29, 2007	0.0	M Hardy / L Ramirez	Initial release
September 25, 2008	0.1	M Hardy	Added RF Warning

TABLE of CONTENTS

Warranty	4
Shipping Damage	4
Customer Service Information	4
<i>Telephone Consultation</i>	4
<i>Field Repair</i>	5
<i>Replacement Module</i>	5
<i>Equipment Returns</i>	5
<i>International Returns</i>	5
<i>Unit Identification</i>	6
1.0 DESCRIPTION & FEATURES	7
1.1. Control Drawer	9
1.2. High Power Amplifier (“HPA”).....	10
2.0 SPECIFICATIONS	13
3.0 INSTALLATION	ERROR! BOOKMARK NOT DEFINED.
3.1. Cable & NYCOIL Planning	15
3.2. Control Drawer Install	15
3.3. Mast Mounted HPA Mechanical Install.....	19
3.4. Mast Mounted HPA Electrical Install	20
4.0 OPERATION	23
4.1. Control Drawer Front Panel	23
4.2. Control Unit Section	24
4.3. Antenna Section	24
4.4. Power Section	24

TABLE of FIGURES

FIGURE 1-1: SINGLE BAND TRUCK PACKAGE BLOCK DIAGRAM	8
FIGURE 1-2: DUAL BAND TRUCK PACKAGE BLOCK DIAGRAM	8
FIGURE 1-3: TRUCK PACKAGE CONTROL DRAWER (FRONT, SHOWN WITH CHANNELMASTER)	9
FIGURE 1-4: TRUCK PACKAGE CONTROL DRAWER (REAR, SHOWN WITH CHANNELMASTER).....	9
FIGURE 1-5: MAST MOUNTED POWER AMP, STANDARD POWER (FRONT).....	10
FIGURE 1-6: MAST MOUNTED POWER AMP, STANDARD POWER (REAR).....	10
FIGURE 1-7: RF MAST MOUNTED POWER AMP, ULTRA HIGH POWER.....	11
FIGURE 3-1: CONTROL DRAWER	15
FIGURE 3-2: RAIL ASSEMBLY	15
FIGURE 3-3: CONTROL DRAWER MOUNTED IN RAIL ASSEMBLY	15
FIGURE 3-4: MOUNTING BRACKET DETAIL.....	16
FIGURE 3-5: INSTALLING THE MOUNTING BRACKETS	16
FIGURE 3-6: LOCKING THE MOUNTING BRACKETS	17
FIGURE 3-7: CONNECTING POWER SOURCE TO CHANNELMASTER	17
FIGURE 3-8: CONNECTING CABLE TO CHANNELMASTER RF OUTPUT	18
FIGURE 3-9: HPA’S MOUNTING ON PAN & TILT (SINGLE-BAND).....	19
FIGURE 3-10: HPA’S MOUNTING ON PAN & TILT (DUAL-BAND).....	19
FIGURE 3-11: RF HEAD CONNECTIONS (IF& ANTENNA POLARIZATION)	22
FIGURE 3-12: RF HEAD CONNECTIONS (RF TO ANTENNA).....	22

Warranty

Equipment manufactured by Nucomm, Inc. is warranted to meet all specifications and to be free from defects in material and workmanship within a period of two years from date of shipment from Nucomm. The company's liability under this warranty is limited to:

- Servicing or adjusting equipment.
- Replacement of defective parts.

Any equipment returned to the factory shall have the freight paid for by the buyer.

Equipment showing damage by misuse, abnormal conditions of operation, or attempts to repair by other than authorized service personal shall be excluded from this warranty. Nucomm, Inc. shall in no event be responsible for incidental injury or property damage. Since Nucomm, Inc. has no control over conditions of use, no warranty is made or implied as to suitability for the customer's intended use, beyond such performance specifications as are made part of the purchase order. There are no warranties expressed or implied, except as stated herein. This limitation on warranties shall not be modified by verbal representations.

Shipping Damage

Equipment shipped FOB Nucomm, Inc.; shall become the property of buyer upon delivery to and receipt from carrier. Any damage in shipment should be handled by the buyer directly with the carrier. Immediately request the carrier's inspection upon evidence of damage in shipment.

Customer Service Information

Customer Service technicians at Nucomm are available to extend technical assistance to customers installing or operating Nucomm equipment. They will also assist customers with equipment troubleshooting. If this cannot be successfully accomplished by telephone, the equipment may be returned to the factory for repair. Loaner equipment is often available until Nucomm is able to ship repaired units. Nucomm evaluates all returned units and then confers with customers on corrective action. If no corrective action is taken, or required, a diagnostic fee may be charged.

Telephone Consultation

Should there be a need for emergency telephone consultation, please have your model number and serial number available for the Customer Service representative. Nucomm Customer Service representatives are available to deal with all technical questions or difficulties.

Telephone:

During Nucomm business hours, 8:30am – 5:30pm EST (-5:00 GMT):

US: (908) 852-3700

International:..... 001 - 1 - (908) 852-3700

24-Hour Hotline:

US: (888) 531-3892

International:..... 001 - 1 - (888) 531-3892

Field Repair

Nucomm products are designed with easy access to components to facilitate service. When troubleshooting, the user is cautioned to read all module descriptions in this manual. Some Nucomm modules cannot be serviced in the field. Warnings are included in the circuit descriptions and on certain modules themselves, however the lack of a warning cannot be construed as a statement of safety. To prevent voiding of the Nucomm warranty that protects the equipment, please contact Nucomm before servicing or making any repairs.

Replacement Module

Troubleshooting to the component level is often not cost-effective and frequently impossible. Often the practical method of effecting field repairs is to substitute known good spare modules for suspect units. Nucomm maintains an inventory of replacement modules for its standard line of products.

Equipment Returns

Do not return any Nucomm product to the factory until you have received a return materials authorization (RMA) number and shipping instructions from Nucomm. When returning equipment to Nucomm, please enclose a letter containing the following:

- RMA number.
- Model number.
- Serial number.
- Frequency operating range (in case of modules).
- A detailed description of the problem.
- Name of engineer or technician we may contact in regards to this problem.
- Include a “ship to” and “bill to” address.

Ship ALL RETURNS to:

Nucomm, Inc.
Attn: RMA
101 Bilby Road
Hackettstown, New Jersey 07840

International Returns

In the case of units being shipped from outside the United States, Nucomm recommends the use of a courier such as Federal Express, UPS, etc., and that the goods be shipped DOOR-TO-DOOR PRE-PAID. This will eliminate Customs costs, handling charges and delays. Enclose all the information above, plus a statement that the equipment was manufactured in the United States (the latter is needed to expedite customs processing).

Unit Identification

Given the model number, the unit configuration can be determined using the following:

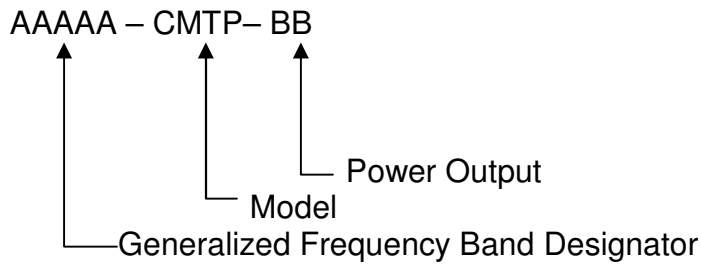

Where:

AAAAA = mean frequency band center in GHz rounded to the closest GHz. This number is then multiplied by 10. For multiple bands, each center frequency designation is separated by a backslash "/".

BB = Used to identify the power output, per the following Power Output Designators:

Power Output is represented by Letters (A-Z; A=1, B=2, C=3, etc) for the analog power, and Numbers (0-9) for the digital power. For example, a 5W Analog / 2W digital system would be described with a power indicator of "E2". A Dual-Band system would have two sets of power indicators, to show the power levels at both bands.

Proprietary & Disclaimer Notice

All information and graphic images herein contained within this manual are considered the sole property of Nucomm, Inc. and are issued in the strictest of confidence. This material may not be reproduced, stored, copied, or converted in any form, nor shall it be disclosed to others or used for manufacturing or any other purpose without the written permission of an authorized representative of Nucomm, Inc.

Nucomm, Inc. has made every effort to ensure the accuracy of this material at the time of printing. However, as the specifications, equipment, and this manual are subject to change without notice, Nucomm, Inc. assumes no responsibility or liability whatsoever for any errors or inaccuracies that may appear in this manual, or for any decisions based on its use. This manual is supplied for informational purposes only and should not be construed as a commitment by Nucomm, Inc.

© Copyrighted 2007, Nucomm, Inc., Hackettstown, New Jersey 07840

1.0 DESCRIPTION & FEATURES

Nucomm's optional TruckMount Package (aka "Truck Package") for the ChannelMaster TX1 provides ENG/OB truck operators the flexibility to use the ChannelMaster TX1 as a full-featured truck transmitter, while retaining the ability to easily remove the transmitter for portable use as required.

The TruckMount Package can be configured for Single or Dual-Band operation, and includes High Power Mast Mounted Amplifier(s) (HPA's) to increase the range of the base ChannelMaster transmitter. The Block Diagrams in Figure 1-1 and Figure 1-2 show the available Single and Dual Band configurations.

The Single Band TruckMount Package consists of a 2RU* "nested docking station" style Control Drawer which accepts the ChannelMaster portable, and a Mast-Mounted HPA which is typically attached to the side of the Pan & Tilt, at the top of a telescoping mast, with a Nucomm mounting plate. The Control Drawer and Mast-mounted HPA are interconnected via SF-214 RF that is typically installed in a NYCOIL assembly for carriage up the mast.

The Dual Band TruckMount Package consists of a 2RU* "nested docking station" style Control Drawer which accepts the ChannelMaster portable, and two Mast-Mounted HPA's which are typically attached to the sides of the Pan & Tilt, at the top of a telescoping mast, with Nucomm mounting plates. The Control Drawer and Mast-mounted HPA's are interconnected via a single SF-214 RF that is typically installed in a NYCOIL assembly for carriage up the mast. In the case of the Dual Band system, the cable from the Control Drawer is first attached to the 7 or 13GHz amplifier, and then routed over to the 2 GHz amplifier.

**Note: Depending on the RF power output level of the ChannelMaster portable transmitter, the overall height of the docked transmitter and Control Drawer may exceed 2RU due to the heat sink fins integrated into the top of the ChannelMaster portable.*

All signals required at the amplifier (RF, Control and Power) are diplexed onto the SF214.

The standard AC power supply for the TruckMount Package Control Drawer has an operating range from 90 to 240 VAC (40 to 60Hz). Optionally, a +11 to +32 VDC power supply, or a Universal Power Supply can be factory installed. The Universal Power Supply operates on 90 to 240 VAC (40 to 60Hz), or +11 to +32 VDC.

2, 7, or 13 GHz Single Band Van/OB TruckMount System

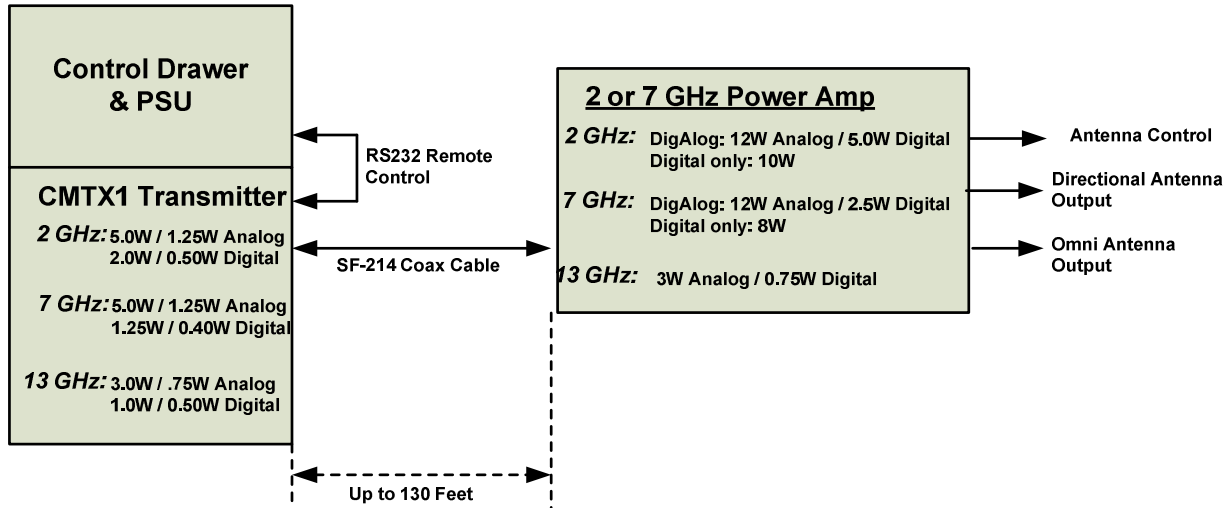

Figure 1-1: Single Band Truck Package Block Diagram

2, and 7 or 13 GHz Dual Band Van/OB TruckMount System

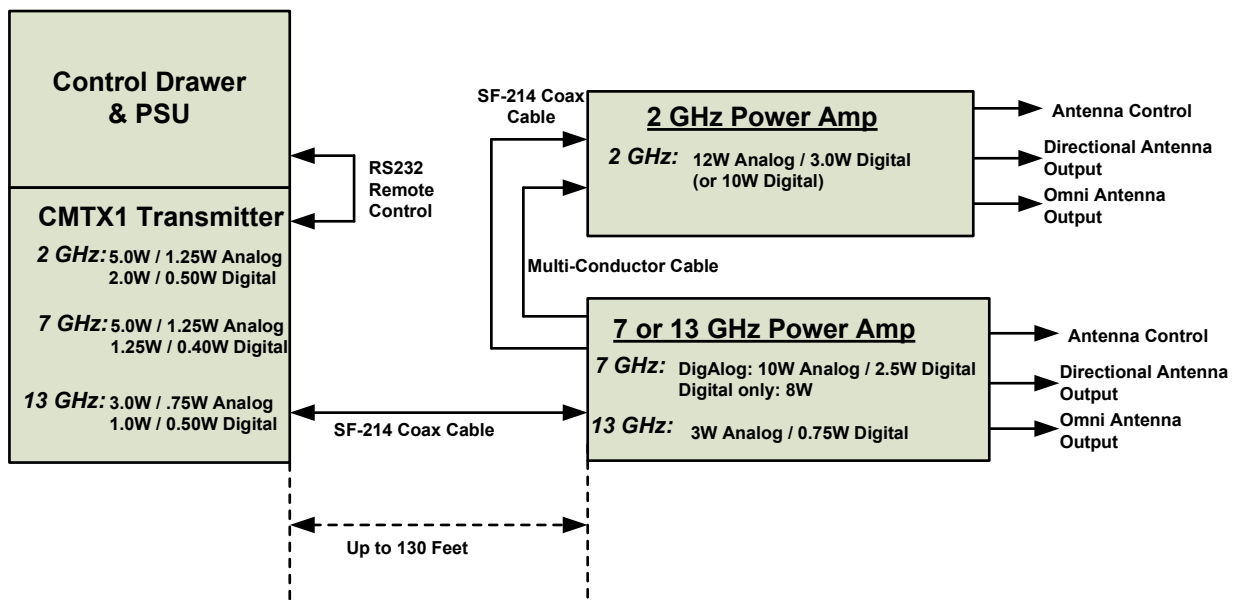

Figure 1-2: Dual Band Truck Package Block Diagram

1.1. Control Drawer

The Truck Package Control Drawer (depicted in Figures 1-3 & 1-4), provides controls for the High Power Amplifier(s), as well as various antenna parameters. The functions are fully described in the Operations section of this manual.



Figure 1-3: Truck Package Control Drawer (front, shown with ChannelMaster)

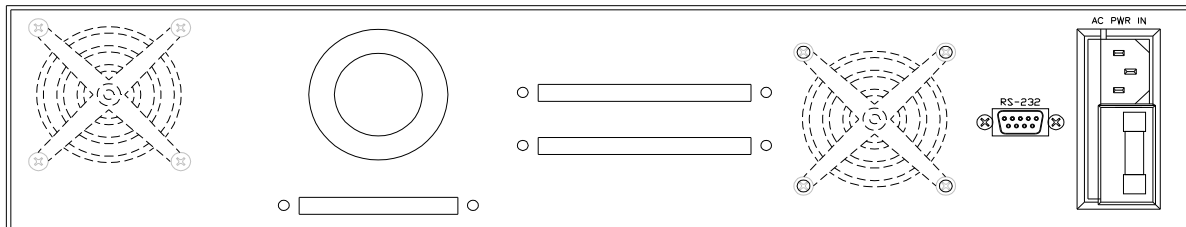

Figure 1-4: Truck Package Control Drawer (rear, shown with ChannelMaster)

1.2. High Power Amplifier (“HPA”)

The Truck Package High Power Amplifier, or “HPA”, (depicted in Figures 1-5 & 1-6) has connectors for the diplexed RF, Power & Control from the Control Drawer, and RF out to the transmit antenna. For Dual-Band systems, in order to minimize NYCOIL cabling requirements, one HPA is designated as “Amp #1” and is configured to accept all signals from the Control Drawer, and route them to Amp #2.

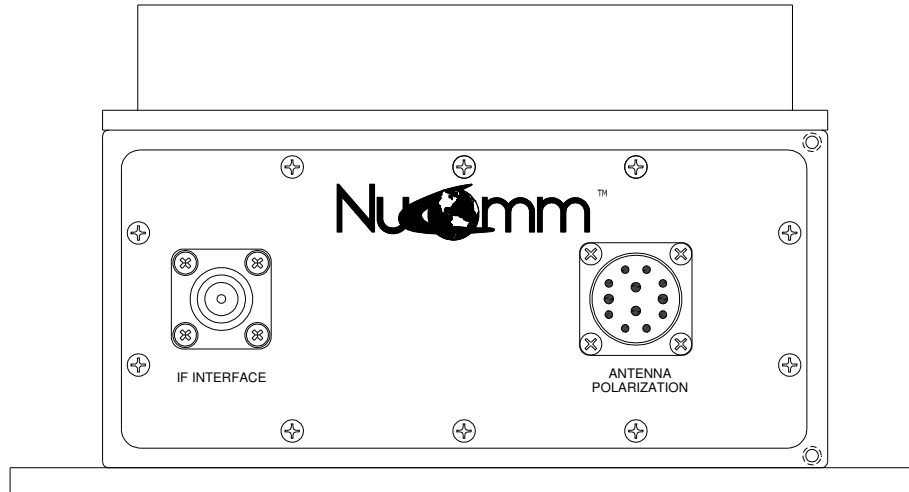

Figure 1-5: Mast Mounted Power Amp, Standard Power (Front)

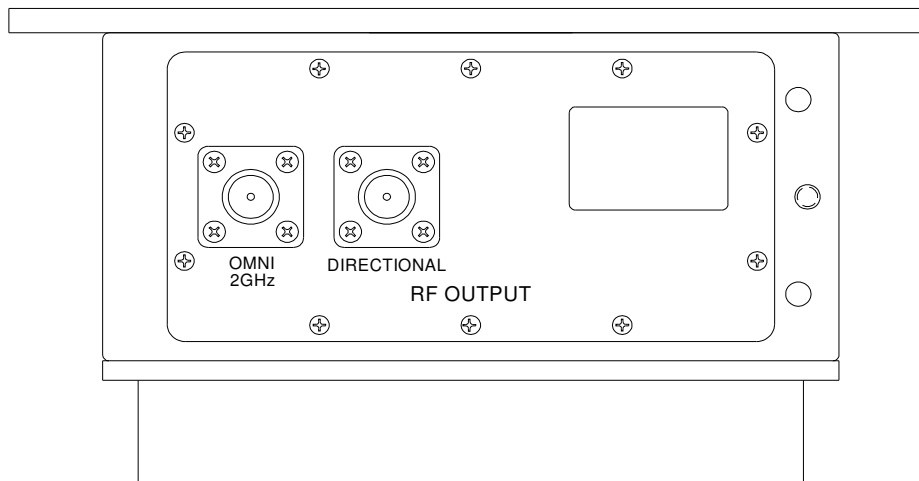

Figure 1-6: Mast Mounted Power Amp, Standard Power (Rear)



Figure 1-7: RF Mast Mounted Power Amp, Ultra High Power



2.0 SPECIFICATIONS

RF Performance:

Frequency Bands:..... bands from 1.9GHz to 13.25GHz available (higher frequencies pending). Multi-band models available. Please contact Nucomm for specifics.

Power Output (for the base ChannelMaster Transmitter)

Power Mode:

Standby: No RF output
 HI Power: Full power
 LOW Power: ~6dB down from full power

Low Power Transmitters:

2 GHz Analog High Power Mode 5.0 Watts
 2 GHz Digital High Power Mode 2.0 Watts
 7 GHz Analog High Power Mode 5.0 Watts
 7 GHz Digital High Power Mode 1.25 Watts
 13GHz Analog High Power Mode TBD
 13 GHz Digital High Power Mode TBD

Medium Power Transmitters:

2 GHz Analog High Power Mode 12.0 Watts
 2 GHz Digital High Power Mode 4.0 Watts
 7 GHz Analog High Power Mode 5.0 Watts
 7 GHz Digital High Power Mode 1.25 Watts
 13 GHz Analog High Power Mode TBD
 13 GHz Digital High Power Mode TBD

Remote Control:

When the ChannelMaster portable is in the 2RU Control Drawer, the drawer controls the ChannelMaster via RS232 lines out of the ChannelMaster front panel power connector.

Power Requirements:..... AC 90 to 240 VAC **or** +11 to +32 VDC.

Environmental:

Temperature range:

Full specification:..... -30° to +60°C

Storage: -40° to +80°C

Humidity: 0 to 95% non-condensing

Physical Characteristics:

Control Drawer (without transmitter):

Size: 2RU x 19" (48.26cm)

Weight: 12.0 lbs (5.45kg)

Mast Mounted High Power Amplifier(s):

Size (housing only): 9.78"(251mm) x 9.125"(231mm) x 5"(125mm)

Size (with connectors): 11.375"(290mm) x 9.125"(231mm) x 5"(125mm)

Weight: 11.75 lbs (5.34kg)

Mast Mounted Ultra High Power Amplifier(s):

Size (housing only): 9.78"(251mm) x 9.125"(231mm) x 6.25"(158mm)

Size (with connectors): 11.375"(290mm) x 9.125"(231mm) x 6.25"(158mm)

Weight: 14.00 lbs (6.36kg)

Connectors:

RF Input/Output: Type "N" female

Audio: XLR

Remote Control: not applicable

All Amplifier Cases: Weather-proofed

3.0 INSTALLATION

3.1. Cable & NYCOIL Planning

The only NYCOIL cable required for the Mast Mounted Amplifier(s) is a single SF214, coaxial cable. Pan & Tilt requirements are not addressed in this manual.

3.2. Control Drawer Install

3.2.1 Gather all components, parts list, and drawing to be used in the assembly of the Control Drawer (Figure 3-1) for the ChannelMaster with HPA. Ensure that all components match the documentation.

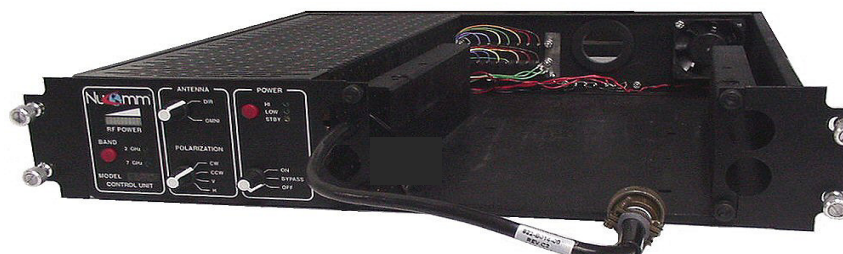

Figure 3-1: Control Drawer

3.2.2 Install Rail Assembly on to rack. Ensure that the assembly is flush against the rack and level. Next fasten the four mounting screws and tighten firmly. (Refer to Figure 3-2.)

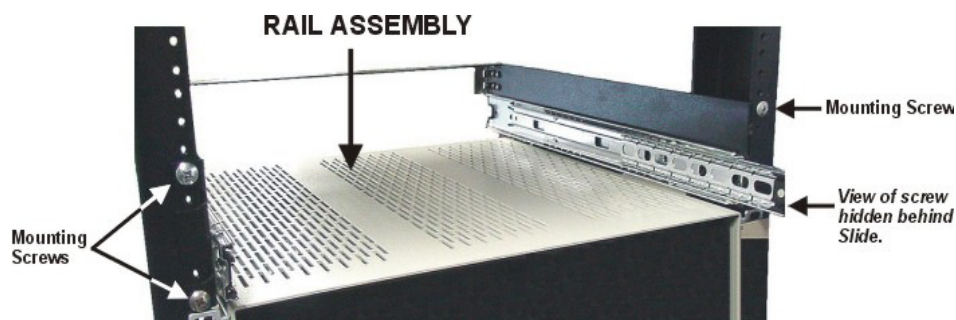

Figure 3-2: Rail Assembly

3.2.3 Slide the Control Drawer into the Rail Assembly until you hear each side “click” (Refer to Figure 3-3).

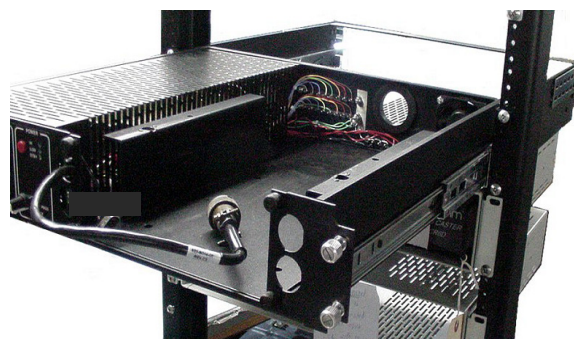

Figure 3-3: Control Drawer Mounted in Rail Assembly

3.2.4 Slide the ChannelMaster into the Control Drawer. Retrieve the two mounting brackets (see Figure 3-4). (Note: On later versions, the bracket is integrated into the housing.)

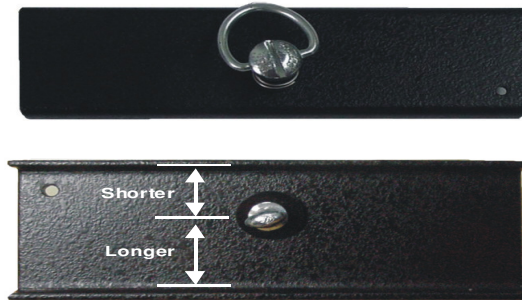

Figure 3-4: Mounting Bracket detail

3.2.5 Properly orient the bracket (*bracket mounts only one way*) and insert one edge of the bracket into the grooves (*on one side of the ChannelMaster*), ensuring that the bracket's fastener aligns with its associated mounting hole. (Refer to Figure 3-5.)

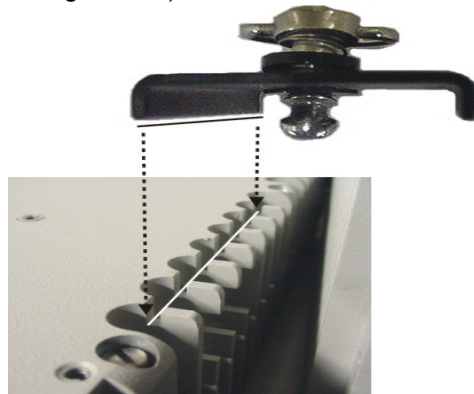

Figure 3-5: Installing the Mounting Brackets

3.2.6 Lock bracket into place by pressing down on fastener and turning it clockwise. Repeat process for other side of ChannelMaster. (Refer to Figure 3-6.)

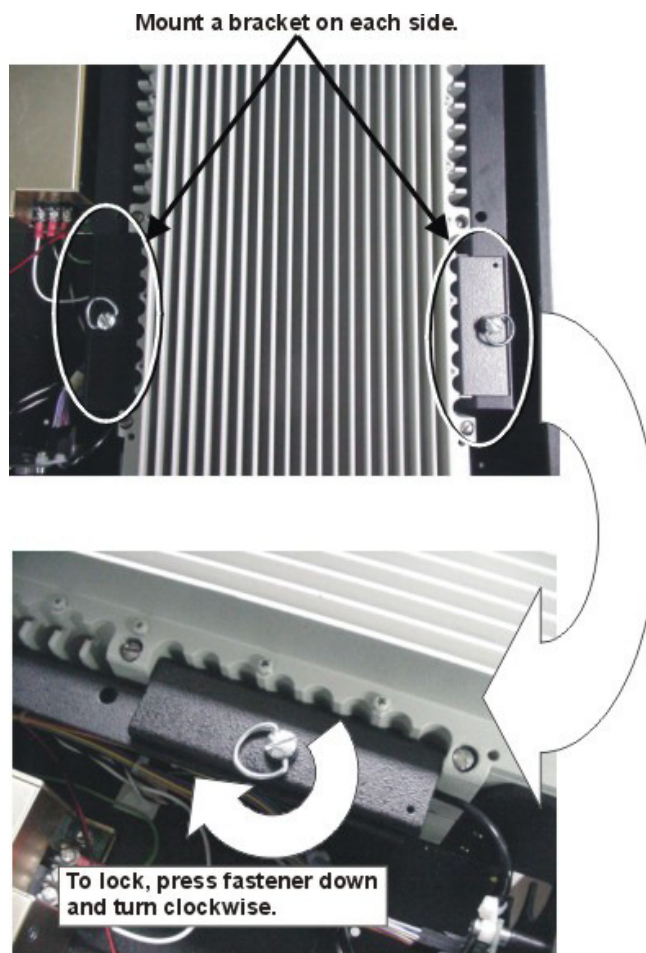

Figure 3-6: Locking the Mounting Brackets

3.2.7 Connect the Power and Audio Cables from front of Control Drawer to Power and Audio Connectors on the ChannelMaster. (Refer to Figure 3-7. Audio not shown).



Figure 3-7: Connecting Power Source to ChannelMaster

- 3.2.8 Diplexer Option Installation - Install Diplexer on RF output connector of ChannelMaster (*N type Connector*). Attach RF cable from Nycoil to output of Diplexer (*N type connector*). (Refer to Figure 3-8). (*The Diplexer is used to combine the +24 power and control signals onto the RF Coax Center Conductor*).

On later versions this step requires lifting up of the integrated fan housing, which may require the drawer assembly to be pulled forward from the rack on the mounting rails.

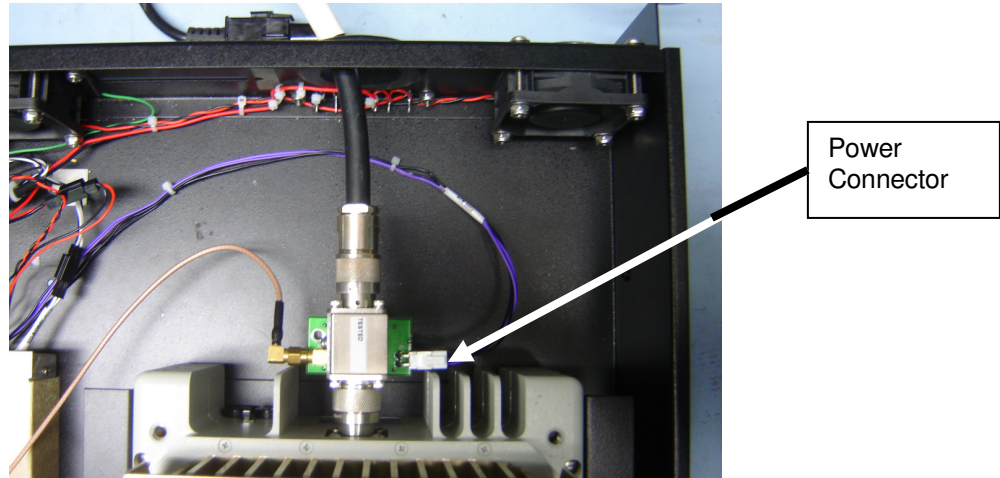

Figure 3-8: Connecting Cable to ChannelMaster RF Output

CAUTION!

DO NOT measure RF power with a Power Meter inserted in the RF + DC path of the coaxial cable UNLESS the power connector (with purple and black wires) shown above has been disconnected.

3.3. Mast Mounted HPA Mechanical Install

The Mast-Mounted HPAs are typically attached to the sides of the Pan & Tilt with Nucomm mounting plates, as shown in Figures 3-9 & 3-10 (Single-Band and Dual-Band respectively).

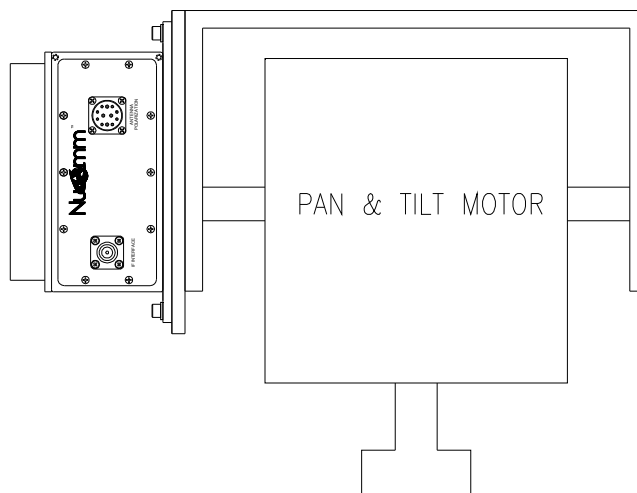

Figure 3-9: HPA's mounting on PAN & TILT (Single-band)

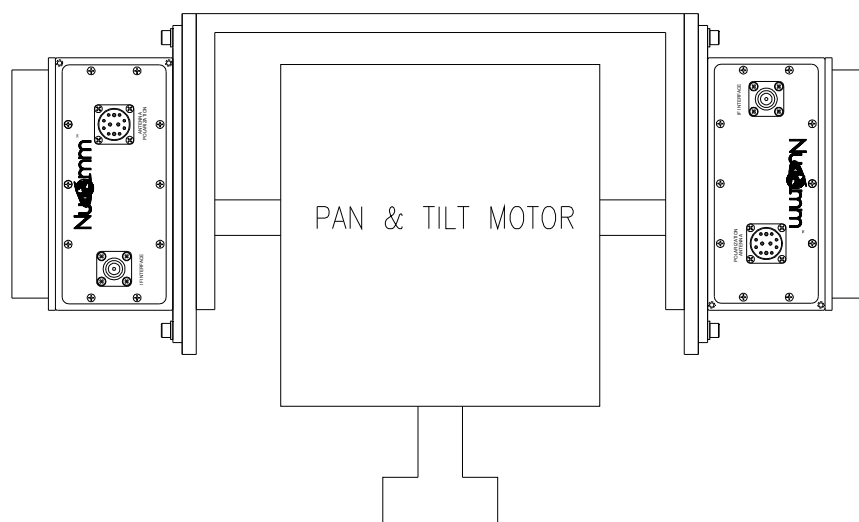

Figure 3-10: HPA's mounting on PAN & TILT (Dual-band)

3.4. Mast Mounted HPA Electrical Install

3.4.1 Prepare antenna control cable per Figure 3.11 (for NSI Antenna) & Figure 3.12 (for Radio Waves Antenna).

NSI Quad Antenna Polarization Connector Pin Out

RF Head Connector Pin	Function	Recommended Wire Size (AWG)	NSI Antenna Connector Pin
N/C	CW (Default)	N/C	N/C
E	V	#22 BROWN	A
C	H	#22 RED	B
D	2/7 GHz Band Select	#22 GREEN	L
F	CCW	#22 WHITE	D
K	Ground	#22 BLACK	E
J	+24v	#22	N/C
G	Polarization Common	#22	N/C
N/C	N/C	N/C	F
N/C	N/C	N/C	H
N/C	N/C	N/C	J
N/C	N/C	N/C	K
N/C	N/C	N/C	M

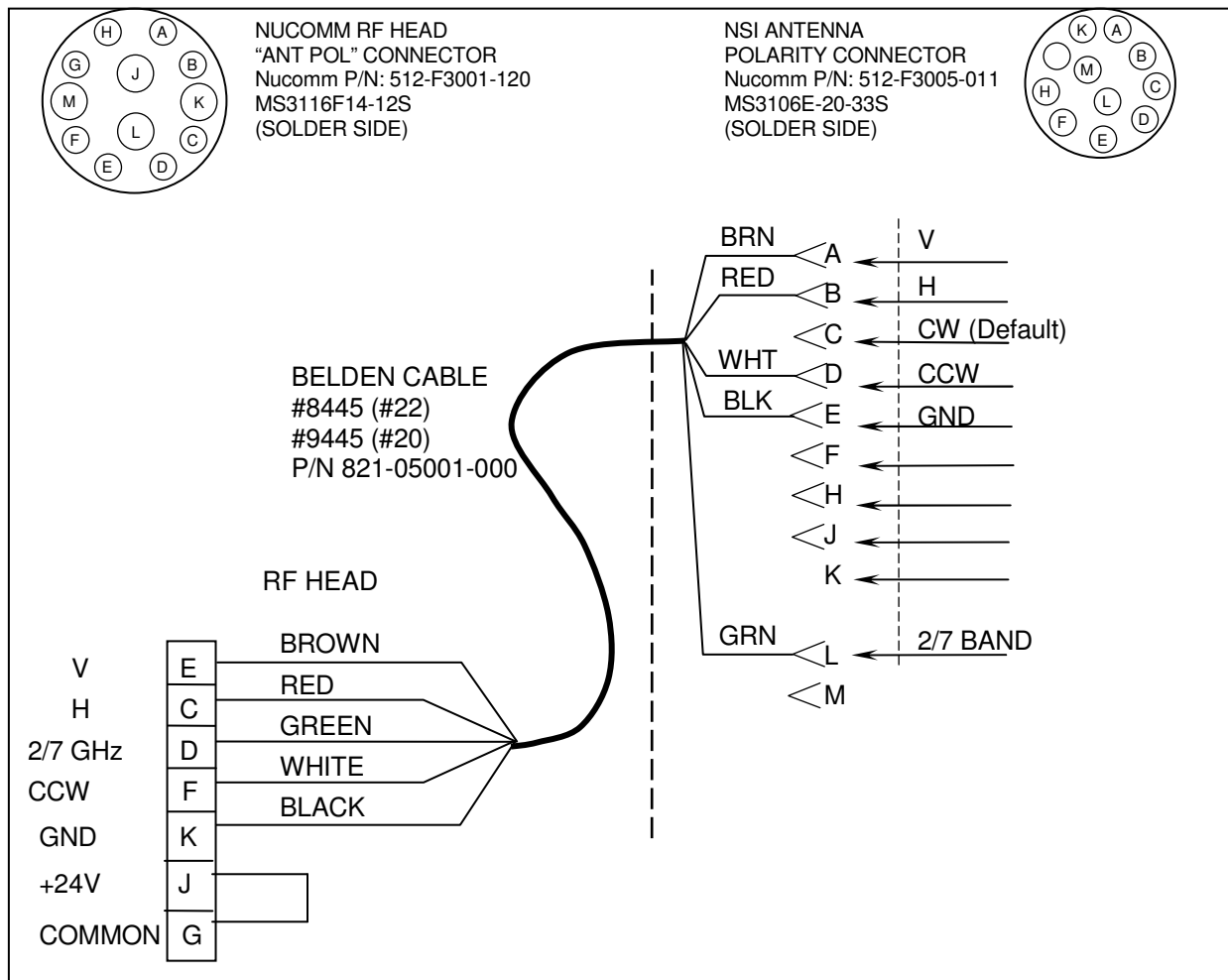

Figure 3-11: NSI Quad Antenna Polarization Connector Pin Out

Radio Waves Quad Antenna Polarization Connector Pin Out

RF Head Connector Pin	Function	Recommended Wire Size (AWG)	Radio Waves Antenna Connector Pin
N/C	CW (Default)	N/C	N/C
E	V	#22 BROWN	F
C	H	#22 RED	B
D	2/7 GHz Band Select	#22 GREEN	G
F	CCW	#22 WHITE	C
J	+24V	#22 BLACK	K
K	GND	#22 BLUE	M
G	Polarization Common	#22	N/C
N/C	Shield GND	#22	L
N/C	N/C	N/C	A
N/C	N/C	N/C	D
N/C	N/C	N/C	E
N/C	N/C	N/C	H
N/C	N/C	N/C	J

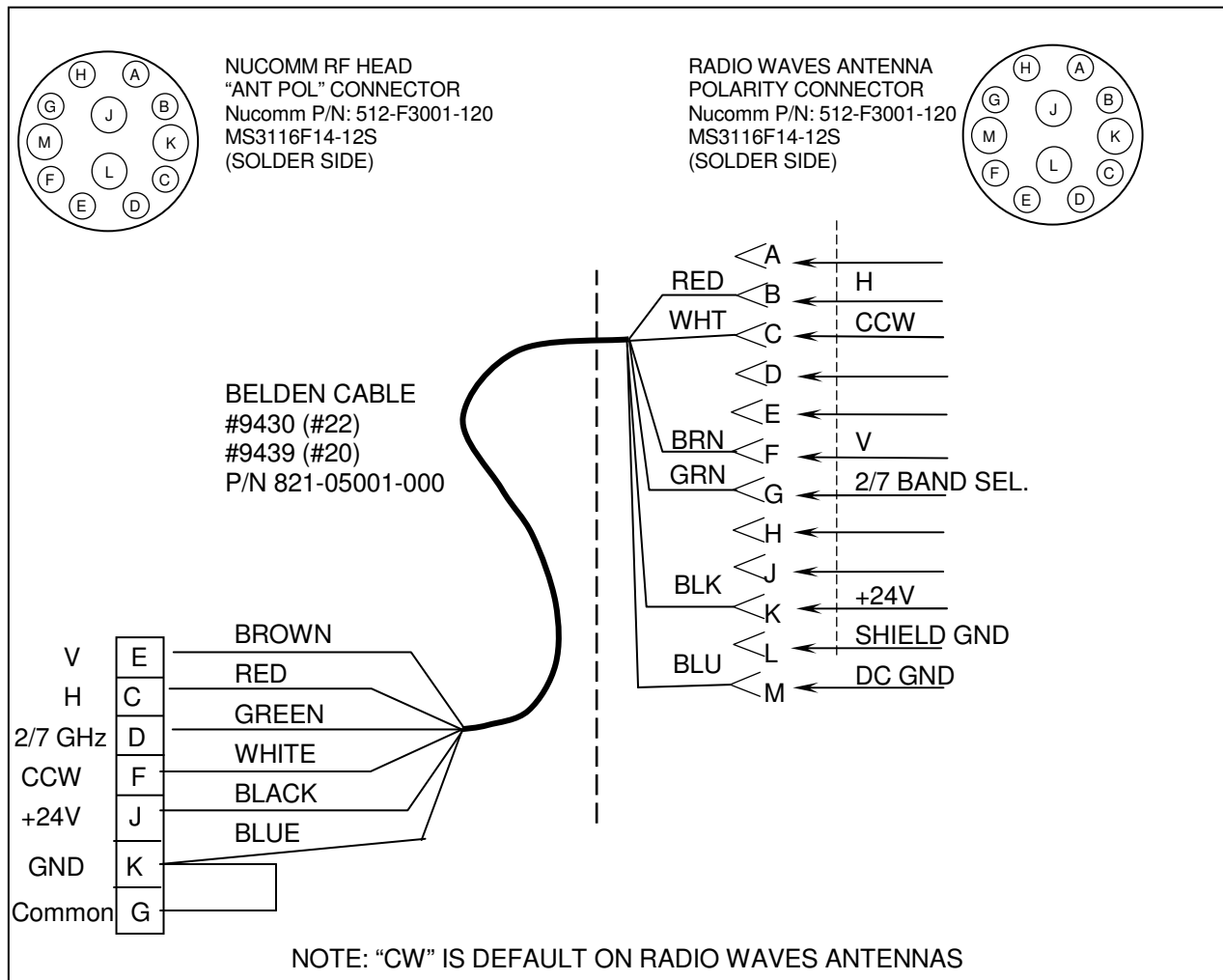

Figure 3-12: Radio Waves Quad Antenna Polarization Connector Pin Out

3.4.2 Make cable connections to RF Head and antenna(s). Refer to figures 3.11 & 3.12.

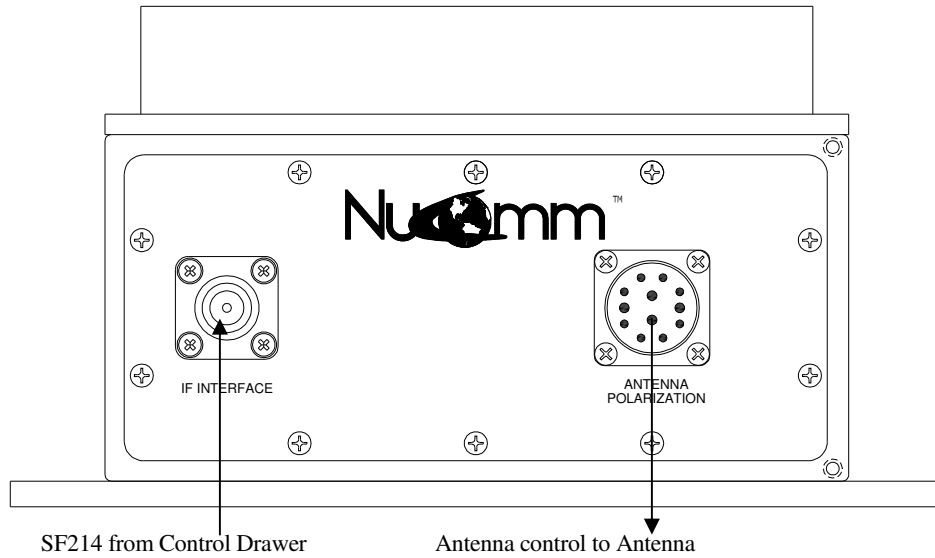

Figure 3-11: RF Head Connections (IF & Antenna Polarization)

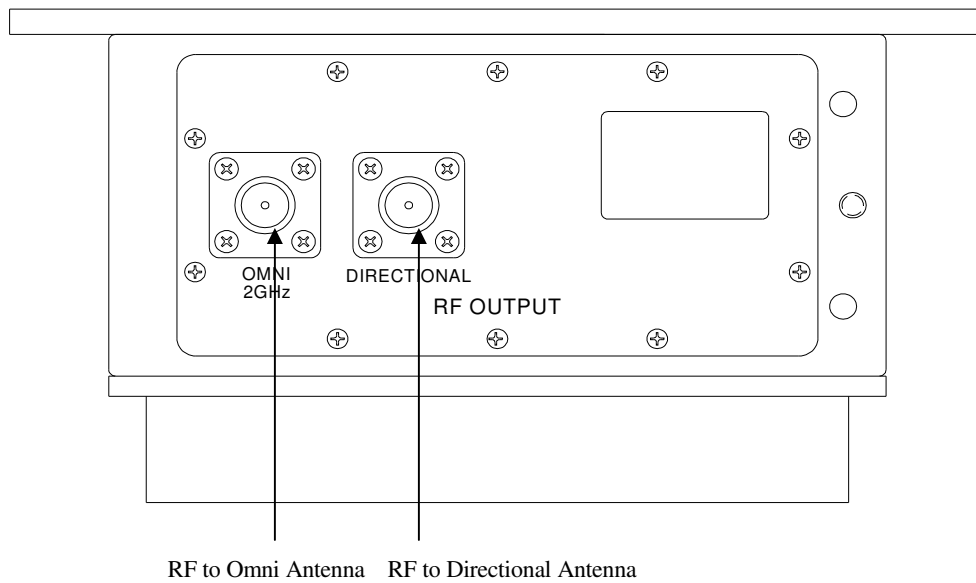

Figure 3-12: RF Head Connections (RF to Antenna)

4.0 OPERATION

4.1. Control Drawer Front Panel

The Control Drawer Front Panel controls the selections related to the use of the 2GHz or 7GHz High Power Amplifiers, as well as selecting various antenna parameters. (Refer to Figure 4-1.) The controls are divided into three sections:

- **Control Unit** - for selecting the Power Amplifier band.
- **Antenna** - for selecting the type of antenna as well as directional antenna polarization.
- **Power** - for selecting the amplifier operation mode as well as overall unit mode.



Figure 4-1: Control Drawer Front Panel

4.2. Control Unit Section

The Control Unit section serves two purposes: the selection of which power amplifier is to be used, and the monitoring of RF output power. The selection of amplifier is accomplished by pressing the “**Band**” Button. The “Band” Button toggles the unit between enabling the 2GHz Amplifier and the 7GHz Amplifier. This feature will still work even if the unit is placed into Bypass Mode.

For monitoring RF output power, a *bar indicator* is located just above the “Band” Button. As the output power increases, so will the length of the bar indicator. However, there is no *direct* number representation.

4.3. Antenna Section

The *upper most rotary switch* in the Antenna Section, allows the operator to choose the type of antenna to be used. The operator can choose between either “Omni” or “Directional”. If “Directional” is chosen, the operator then must set the *lower most rotary switch* for the type of polarization to be used with the antenna.

There are four options:

- **CW** - Clockwise
- **CCW** - Counter-Clockwise
- **V** - Vertical
- **H** - Horizontal

4.4. Power Section

The Power Section allows the operator to select the *unit’s mode of operation*.

For choosing the unit’s mode of operation, the *lower rotary switch* can select one of three conditions:

- **OFF** - The entire Control Unit is powered-off.
- **BYPASS** - The Mast Mounted Power Amplifier is powered down, while the RF signal from the ChannelMaster is sent directly to the antenna via the Power Amp Bypass Relays. Bypass Mode is used to further reduce the RF Power Level sent to the Antenna.
- **ON** - Allows the chosen power amplifier (*refer to “Band” Button*) to amplify the RF output signal being applied to the Antenna.

If “ON” is chosen as the *unit’s mode of operation*, the *amplifier mode of operation* must then be selected. This is accomplished by pressing the upper toggle button until the desired amplifier mode is decided upon. There are three options:

- **HI** - places the *Mast Mounted* Power Amplifier in high power operation.
- **LOW** - places the *Mast Mounted* Power Amplifier in low power operation.
- **STBY** - places the Channel Transmitter in Standby Mode.





Nucomm Inc.
101 Bilby Road
Hackettstown, NJ 07840
Tel: 908-852-3700 Fax: 908-813-0399
www.Nucomm.com