



CHANNELMASTER TX7

Portable Microwave Transmitter



User Manual

NUCOMM PUBLICATION: M01-0029-00A, REV 1.03

FCC STATEMENT

This equipment has been tested and found to comply with Part 74.637 (a) (2) of the FCC Rules and Regulations. Any unauthorized changes or modifications not expressly approved by Nucomm, Inc. could void the user's authority to operate the equipment, and invalidate the equipment's warranty.

CAUTION!

RISK OF ELECTRICAL SHOCK. DO NOT REMOVE EQUIPMENT COVERS.

- Do not remove any equipment covers.
- Refer servicing to qualified technicians only.
- Disconnect all power before servicing.
- Read and perform all instructions carefully. Failure to follow suggested instructions and guidelines may void all warranties.

Proprietary Information and Disclaimer Notice

All information and graphic images contained within this manual are the sole property of Nucomm, Inc. and are issued in the strictest of confidence. This material may not be reproduced, stored, copied, or converted in any form, nor shall it be disclosed to others or used for manufacturing or any other purpose without the written permission of an authorized Nucomm representative.

Nucomm, Inc. has made every effort to ensure the accuracy of this material at the time of printing. However, as the specifications, equipment, and this manual are subject to change without notice, Nucomm, Inc. assumes no responsibility or liability whatsoever for any errors or inaccuracies that may appear in this manual, or for any decisions based on its use. This manual is supplied for informational purposes only and should not be construed as a commitment by Nucomm, Inc.

Warranty

Equipment manufactured by Nucomm, Inc. is warranted to meet all published specifications and to be free from defects in material and workmanship within a period of two years from date of shipment from Nucomm. The company's liability under this warranty is limited to:

- Servicing or adjusting equipment.
- Replacement of defective parts.

Any equipment returned to the factory shall have the freight paid for by the buyer.

Equipment showing damage by misuse, abnormal conditions of operation, or attempts to repair by other than authorized service personnel shall be excluded from this warranty. Nucomm, Inc. shall in no event be responsible for incidental injury or property damage. Since Nucomm, Inc. has no control over conditions of use, no warranty is made or implied as to suitability for the customer's intended use, beyond such performance specifications as are made part of the purchase order. There are no warranties expressed or implied, except as stated herein. This limitation on warranties shall not be modified by verbal representations.

Shipping Damage

Equipment shipped FOB Nucomm, Inc.; shall become the property of buyer upon delivery and receipt from carrier. Any damage in shipment should be handled by the buyer directly with the carrier. Immediately request the carrier's inspection upon evidence of damage in shipment.

Field Service

Nucomm products are designed with easy access to components to facilitate service. However, some Nucomm modules cannot be service in the field. To prevent voiding of the Nucomm warranty, please contact Nucomm before servicing or making any repairs. The user is cautioned to read all module descriptions in this manual. Warnings are included in the circuit descriptions and on certain modules themselves.

Replacement Modules

Troubleshooting to the component level is often not cost-effective and frequently impossible. Often the practical method of effecting repairs is to substitute known good spare modules for suspect units. Replacement modules for Nucomm's standard product line are usually available.

Technical Support Information

Technical Support personnel are available to extend technical assistance to customers while installing, operating, or troubleshooting Nucomm equipment. Please have your model number and serial number available.

Telephone

During Nucomm business hours, 8:30am - 5:30pm EST (-5 Hours, GMT), call:

US908-852-3700

International.....001-1-908-852-3700

After hours, call:

US or International.....888-531-3892

Email

Email address.....service@nucomm.com

Internet

Web addresswww.nucomm.com

Equipment Returns

If equipment cannot be successfully restored through telephone consultation, return to the factory may be required. Loaner items may be available until the repaired items are returned.

For out-of-warranty equipment only: Nucomm evaluates all returned units, and then confers with the client on corrective action. If no fault is found, or no corrective action is authorized, a diagnostic fee may be charged.

Prior to returning a Nucomm product to the factory, please obtain a return material authorization (RMA) number and shipping instructions from Nucomm.

When returning equipment to Nucomm, it is very helpful to enclose a note containing the following:

- RMA number.
- Serial number.
- A detailed description of the problem.
- Name of an engineer or technician we may contact regarding problems encountered.
- A “ship to” and “bill to” address.

Ship all returns to:

Nucomm, Inc
Attn: RMA# (your RMA number)
101 Bilby Rd
Hackettstown, NJ 07840, USA
(908) 852-3700

For International returns:

In addition to the instructions above, when shipping internationally Nucomm recommends the use of a courier such as Federal Express, UPS, etc, and that the goods be shipped DOOR-TO-DOOR PRE-PAID. This will reduce Customs costs, handling charges and delays. Enclose all the information above, plus a statement that the equipment was manufactured in the United States (*the latter is needed to expedite customs processing*).

TABLE OF CONTENTS

1.	PRODUCT DESCRIPTION	1-1
1.1	Introduction	1-1
1.2	Model Numbering Scheme	1-2
2.	FEATURES	2-1
2.1	Feature Overview	2-1
2.2	System Functional Block Diagram	2-3
2.3	System Chassis Features	2-4
2.4	User Interface Overview	2-4
2.5	Standby Mode	2-4
2.6	Video Signal Encoding	2-4
2.7	Audio Sub Carriers	2-4
2.8	Multi-Mode Modulator	2-4
2.9	Multi-band Microwave Output	2-5
2.10	Signal Strength Indicators	2-5
2.11	Video Presence Detector	2-5
2.12	Remote Control Feature	2-5
2.13	Power Supply	2-5
2.14	Internal Self-Test	2-5
2.15	Other Standard Features	2-5
2.16	Options	2-6
2.17	Accessories	2-6
2.18	Flexibility	2-6
3.	SPECIFICATIONS AND FREQUENCY PLANS	3-1
3.1	Frequency Plans (USA)	3-6
4.	INSTALLATION	4-1
4.1	Unpacking and Inspection	4-1
4.2	Pre-Installation Checkout	4-1
4.3	Mechanical Installation	4-1
4.4	Electrical Installation	4-3
4.5	Power Connection	4-3
4.6	ASI, SDI, Composite & 70MHz Ports	4-3
4.7	RF OUTPUT	4-4
4.8	Serial Port	4-4
4.9	POWER SWITCH and FUSES	4-4
4.10	Models with Multi-Pin "MS" Style Audio Connectors	4-4
4.11	Models With XLR Audio Connectors	4-4
4.12	Firewire	4-4
5.	OPERATION	5-1
5.1	Power Up Displays	5-1
5.1.1	Changing Characters	5-2
5.2	Front Panel Buttons	5-2
5.2.1	Changing Operating Frequency	5-3
5.3	Using Presets	5-3
5.4	Status Indicators & Test Gen	5-6
5.5	Main Menu Selections	5-7
5.6	Input Menu Selections	5-7
5.7	Modulation Menu Selections	5-8
5.7.1	FM	5-8
5.7.2	COFDM	5-9
5.7.3	VSB	5-12
5.8	Encoder Menu Selections	5-12

5.8.1	AUDIO	5-12
5.8.2	VIDEO	5-13
5.8.3	SERVICE	5-13
5.9	System Menu Selections	5-13
5.9.1	OPTIONS	5-14
5.9.2	REMOTE	5-14
5.9.3	VERSION	5-14
5.9.4	RESTORE	5-15
5.9.5	FREQUENCY	5-15
5.9.6	FACTORY	5-15
5.9.7	BAS	5-15
5.10	Monitoring Menu Selections	5-15
5.10.1	MONITOR	5-15
5.10.2	ALARM	5-16
5.11	BAS Relocation Settings	5-17
5.11.1	Audio Sub-Carrier Frequency	5-17
5.11.2	Channel Bandwidth and Band Plan	5-18
5.11.3	Switchover to "Post-relocation" Settings	5-18

LIST OF TABLES

Table 2-1:	ChannelMaster TX7 Technical Features and Benefits	2-2
Table 3-1:	ChannelMaster TX7 Specifications	3-1
Table 3-2:	Frequency Plan (US), 2GHz 17MHz	3-6
Table 3-3:	Frequency Plan (US), 2GHz 12MHz	3-7
Table 3-4:	Frequency Plan (US), 6/7GHz	3-8
Table 3-5:	Frequency Plan (US), 12/13 GHz	3-9
Table 5-1:	ChannelMaster 8 MHz B/W Data Rates	5-10
Table 5-2:	ChannelMaster 7 MHz B/W Data Rates	5-11
Table 5-3:	ChannelMaster 6 MHz B/W Data Rates	5-11
Table 5-4:	VSB Data Rates for BW=6 MHz	5-12

LIST OF FIGURES

Figure 2-1:	ChannelMaster TX7 Functional Block Diagram	2-3
Figure 4-1:	Pre-Installation Checkout Equipment Configuration	4-1
Figure 4-2:	CMTX7 Mounting Hole Locations and Screw Sizes	4-2
Figure 4-3:	CMTX7 Unit with Shroud	4-3
Figure 4-4:	CMTX7 Unit with Shroud (Shows Built-in Cooling Fans)	4-3
Figure 4-5:	ChannelMaster TX7 Front Panel (Mil Connector Version)	4-5
Figure 4-6:	ChannelMaster TX7 Front Panel (XLR Version)	4-6
Figure 4-7:	ChannelMaster TX7 Rear Panel (All Models)	4-7
Figure 4-8:	Power and RS-232 Connector Pin-Outs and Part Information	4-8
Figure 4-9:	AC Line Cord Construction	4-8
Figure 4-10:	RS232/RS485 Connector Pin-Outs	4-9
Figure 4-11:	Firewire Input Connector (Optional)	4-9
Figure 4-12:	Audio Cable Connections	4-10
Figure 4-13:	XLR Breakout Cable	4-11
Figure 4-14:	3-PIN XLR Input Pin Assignments (2 Audio Inputs)	4-12
Figure 5-1:	ChannelMaster TX7 Front Panel Controls and Indicators	5-1

DOCUMENT REVISION HISTORY

Date	Revision	Modified by	Description
February 19, 2009	1.0	JB	Initial version.
February 20, 2009	1.01	MH	Edited Table 3-1 and Chapter 3.
March 10, 2009	1.02	JB	Minor revisions.
April 1, 2009	1.03	JB	Edited menu description, US Frequency Plan band range info in Ch 3. Added section on "COFDM Guidelines."

Nucomm makes every effort to ensure our documentation is accurate, and as complete as possible. In the event that you find any errors or omissions in our documentation, please contact Nucomm Customer Service at (908) 852-3700, or via email at service@nucomm.com.

Nucomm Publication: M01-0029-00A
© Copyrighted 2009, RF Extreme, Inc., Hackettstown, New Jersey 08740



1. PRODUCT DESCRIPTION

1.1 Introduction

Nucomm's ChannelMaster TX7 is a Digital-Analog Portable Microwave Transmitter. The tripod mounted Microwave Transmitter System is designed to operate in any specified band in the 1.00 GHz to 15.5 GHz frequency range. Each unit is field programmable and configurable to meet a wide range of customer requirements. The TX7 may be configured for dual band or tri-band operation.

The ChannelMaster TX7 is designed to be an extremely flexible system. It is fully integrated with an MPEG2 compliant super-low delay Encoder, a Multi-mode Digital Modulator, and an Analog FM modulator. Outputs include ASI and microwave RF in the frequency bands mentioned above.

The CMTX7 design uses advanced software defined radio techniques and supports both COFDM and VSB digital modulation. As additional digital modulation formats become available, the system software can easily be updated to support them.

The ChannelMaster TX7 includes inputs for Composite Video, HD-SDI and SD-SDI, ASI, Firewire, and 70 MHz modulated signals.

The system comes standard with two analog audio channels or one digital AES channel. Optionally, the system can support four analog audio channels or two digital AES channels.

The system features an LCD display for control and monitoring, an easy to use menu driven user interface, fifteen user defined presets, field programmable RF and Audio Sub-carrier frequencies, adjustable RF power, and integrated dynamic color bars. A built-in serial interface can be used for remote control and monitoring. Special menus have been included to ease the BAS (US) relocation process.

Available options include a high power amplifier, multi-band operation, and standby power sourcing. Contact Nucomm for information about additional options.

This manual covers all configurations and options for the series within the 1.00 GHz to 15.5 GHz frequency range.

1.2 Model Numbering Scheme

Given the model number, a unit's configuration can be determined using the following:

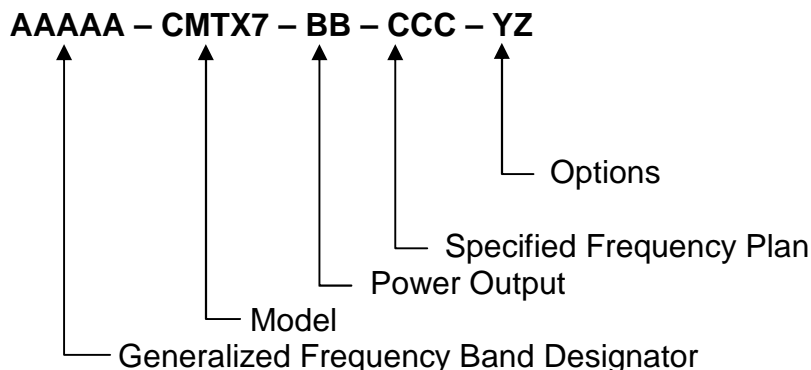

Where:

AAAAA = mean frequency band center in GHz rounded to the closest GHz. This number is then multiplied by 10. For multiple bands, each center frequency designation is separated by a backslash "/".

BB = Used to identify the power output, per the following Power Output Designators:

Power Output is represented by Letters for the analog power (as listed in the table below), and Numbers (0-9) for the digital power. For example, a 5W Analog / 2W digital system would be described with a power indicator of "E2". A Dual-Band system would have two sets of power indicators, to show the power levels at both bands.

LETTER DESIGNATOR	Analog Power (Watts)
A	1
B	2
C	3
E	5
J	10
L	12

Example: For A Dual Band 2 + 7 GHz radio with these power ratings:

2 GHz: 12 Watt Analog, 5 Watt Digital

7 GHz: 5 Watt Analog, 1.5 Watt Digital

AAAA/AAAA = 20/70, and

BB/BB = L5/E1.5

Thus the above model number be similar to:
20/70-CMTX7-L5/E1.5-CCC-YZ

CCC = Nucomm assigns a frequency plan number for each unique frequency channel combination. Contact your Nucomm representative for further information.

YZ = Miscellaneous options as listed in the table below. The model number is formed by appending as many letter codes as appropriate.

LETTER CODE	OPTION
	AUDIO
A2	2 AUDIO
A4	4 AUDIO
B	AES ENCRYPTION
X	XLR AUDIO
	MODULATION + VIDEO
C2	COFDM / FM
C4	COFDM / HD ENABLED
C8	COFDM / FM / HD ENABLED
C10	FM ONLY
C12	COFDM / FM / VSB / HD ENABLED
C15	COFDM / FM / VSB / HD READY
C17	COFDM / FM / HD READY

Options that are not a standard part of the system are indicated in this manual by shaded text as shown here.



2. FEATURES

This chapter describes the features of the ChannelMaster in detail.

The CMTX7 supports an extensive range of popular digital video input formats, including SDI, ASI, and optional Firewire (IEEE1394). The CMTX7 can also be used to transmit 70MHz IF input signals containing audio and video that have been modulated by other equipment.



Nucomm ChannelMaster TX7

2.1 Feature Overview

Nucomm's ChannelMaster TX7 Series Digital-Analog Portable Microwave Transmitters contain among the most comprehensive set of portable radio features available. The ChannelMaster TX7 features are designed for both Digital transmission (either HD or SD video) and Analog (standard definition only) in such applications as ENG/OB trucks, portable links, helicopters, etc.

Table 2-1: ChannelMaster TX7 Technical Features and Benefits

Technical Feature	Benefit
HD and SD video microwave link	Supports HD cameras and older NTSC and PAL cameras.
User friendly menu driven interface	Ease of Use.
Pushbutton controls	Main controls conveniently available.
Preset settings buttons	Simple re-use of system setup.
Advanced digital transmission options (COFDM or VSB digital modulation) using any system video input type.	High integrity digitally modulated signals and microwave transmission.
ASI input - HD and SD MPEG2 video transport stream.	Common on professional video equipment.
SDI input - HD and SD video transport stream.	Common on pro video cameras.
IEEE 1394 Firewire Digital Video Input	Common on pro video cameras.
Composite Video Input - SD (NTSC and PAL) support for composite video.	NTSC and PAL support.
Up to Four Analog Audio Inputs	Balanced audio signals. High noise immunity over long distances. CMTX7 with two XLR input option provides phantom microphone power on right XLR connector.
Up to Two Digital Audio (AES) Inputs	Supports Audio Engineers Society digital audio interface specifications. High SNR using digital interface.
MPEG2 Video Encoder	Composite and SDI inputs can be digitally encoded before modulation and transmission. Also, the MPEG2 encoder can be used to produce an ASI output signal from Component or SDI video input.
Three Modulation Modes: COFDM, VSB, and Analog FM	Flexible options. Digital Modulation methods offer quality and reliability. Analog FM modulation is useful for legacy support.
COFDM Modulation	Digital modulation provides high signal path integrity characteristics and resistance to transient issues such as RF noise sources.
VSB Modulation	VSB offers greater robustness than COFDM for larger throughput applications in clear line of sight conditions.
Analog FM Modulation	For use with Analog FM video receiving equipment.
SDI input to Composite Video and De-embedded Audio	For analog FM transmission of digital video.

2.2 System Functional Block Diagram

The figure below shows a functional block diagram of the ChannelMaster CMTX7.

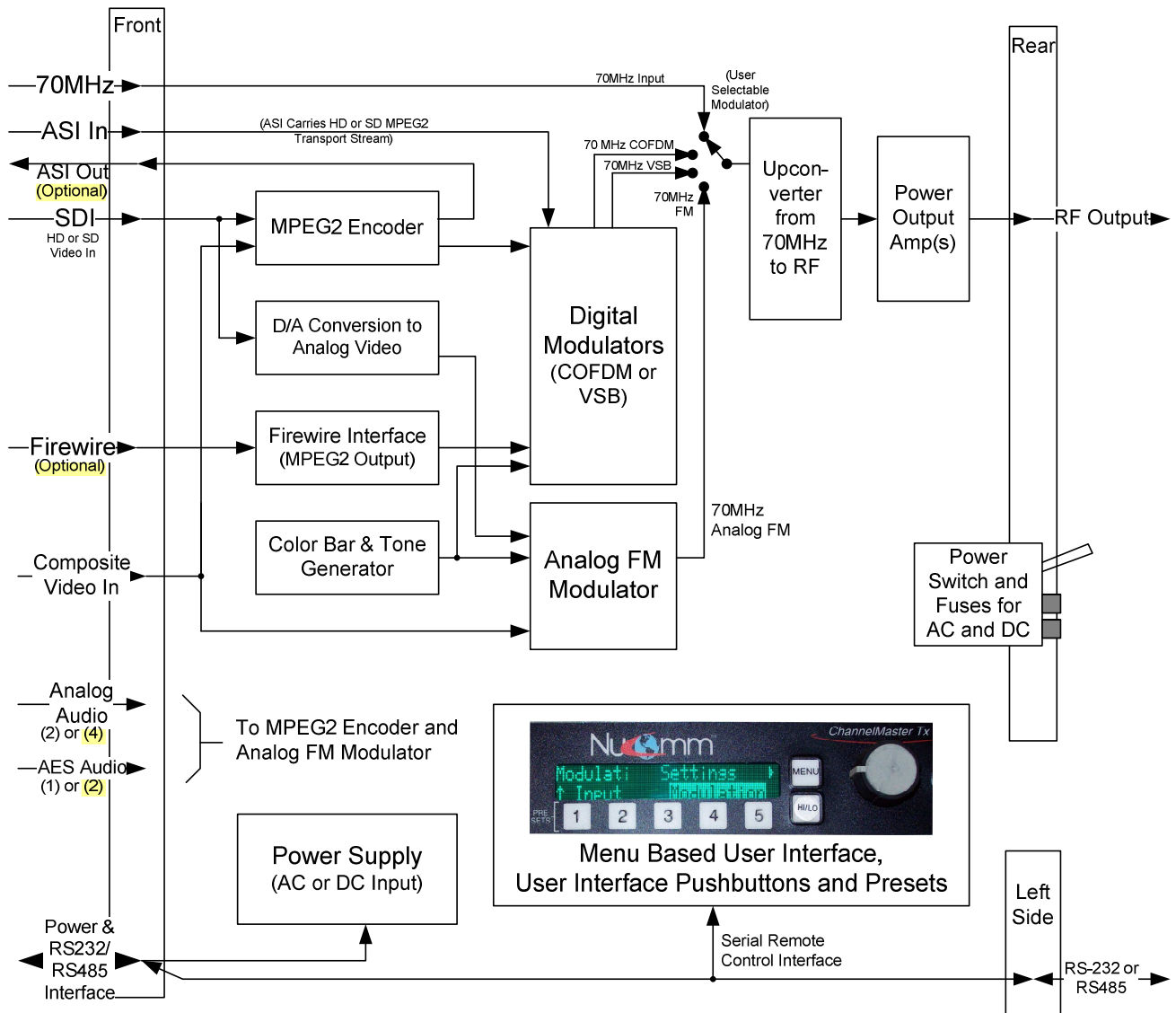

Figure 2-1: ChannelMaster TX7 Functional Block Diagram

2.3 System Chassis Features

The ChannelMaster TX7 features a robust, weather-resistant housing design to withstand rough handling in the field. The ChannelMaster TX7 includes video and audio processing boards, power supply, 70 MHz modulator, power amplifier, up-converter, and low noise frequency synthesizer enclosed in a rugged enclosure, with all input jacks and user interface controls on the front panel. The system chassis is typically tripod mounted during use.

2.4 User Interface Overview

The user interface is conveniently located on the front panel, and has three elements:

1. A menu list for changing system setup configuration options.
2. Preset buttons which can be used to quickly change between setup configurations.
3. Pushbuttons for operating commonly used controls (e.g. Digital/Analog and Transmit Mode).

2.5 Standby Mode

In the *Standby* mode, the ChannelMaster TX7 is powered on, but the RF output is muted, enabling the transmitter to be tuned safely without radiating *off-frequency* emissions. The ChannelMaster TX7 will remain in *Standby* until on-frequency lock has been obtained. Switching from *Standby* to *Normal* mode results in instantaneous on-frequency transmission.

2.6 Video Signal Encoding

The CMTX7 features a built-in MPEG2 compliant digital encoder which transforms Composite Video and SDI inputs

into the MPEG2 format. The ASI input and optional Firewire are already in MPEG2 format.

Optionally, the MPEG2 encoded signals can be routed to an ASI output jack.

Signals from the MPEG2 encoder, the ASI input, or the optional Firewire digital video input can be digitally modulated for transmission using the system's available digital modulation modes.

2.7 Audio Sub Carriers

Two (*four optional*) field programmable synthesized audio sub-carriers feature individual LINE, MIC, AES, EMBEDDED, and TONE source selection (plus an OFF setting), and automatic gain control (AGC). The sub-carrier frequencies, Mode, and additional gain are front panel adjustable using the LCD interface. In the model with optional XLR connectors, the right XLR jack can be used as a microphone input with or without 10 Volt phantom power.

2.8 Multi-Mode Modulator

The table below summarizes the modulation types available.

Modulation Mode	Name	Modulation Technique
1	COFDM	Digital
2	Analog FM	Analog
3	VSB	Digital

2.9 Multi-band Microwave Output

Nucomm's ChannelMaster transmitters are available in single, dual, and multi-band models.

An antenna (*supplied separately*) can be either mounted directly to the transmitter using available mounting adapters or it can be remotely mounted and connected to the transmitter via standard RF cables with N-Type connectors.



The ChannelMaster radios provide full coverage of the 2, 7, & 13 GHz US frequency

bands and/or other bands as required internationally, from 1 GHz to 15.5 GHz. The US frequency bands are given in Table 3-2 through Table 3-5. Band and channel selections are made and clearly displayed via the Front Panel LCD Interface.

2.10 Signal Strength Indicators

Transmitted signal strength is indicated on the LCD display by a digital readout that indicates the transmitted signal level directly in dBm. (*The signal strength display is intended as an approximate reading of power only.*)

2.11 Video Presence Detector

The Video Presence Remote Standby mode enables the camera to remotely turn on the color bars or put the ChannelMaster in standby based upon the detection of video presence at the input port.

2.12 Remote Control Feature

Two RS232/RS485 ports are available to control the system remotely. One is located on the left side of the unit's housing, and the other is located within the front panel power supply connector.



2.13 Power Supply

All standard ChannelMaster's feature a built-in power supply, which automatically covers all the input voltage ranges listed in Table 3-1, without requiring any user intervention.

Optional Power configurations:

Standby Power: For power redundancy, ChannelMaster's can be configured to accept both AC **AND** DC simultaneously. The unit will continue to operate if at least one of the inputs is present.

DC Only: The ChannelMaster may be configured for "DC only" source voltage.

2.14 Internal Self-Test

Built-in diagnostic features include a 1 kHz audio test tone and a 761.5 kHz (1.512 MHz for PAL) video deviation test signal.

2.15 Other Standard Features

- Digitally synthesized microwave oscillator tuning
- Independent Gain Control for audio inputs (*Two audio sub-carriers standard, four optional*)
- Selectable power levels
- Test Pattern/ID Test Generator with:
 - SMPTE RS-170A Color Bars (*EBU Pattern*)

- A 16-character programmable ID (*can be placed in the Vertical Interval and Gen-locked to the incoming Video signal*)

2.16 Options

- Dual front panel XLR connectors with phantom power for mic inputs.
- Front panel Firewire connector for SD or HD MPEG2 digital input stream.
- High Power Amplifier enabling enhanced MER.

2.17 Accessories

ChannelMaster TX7 transmitters ship with AC & DC power cords and manual.

2.18 Flexibility

With the addition of a modem, the ChannelMaster can pass DS3/E3 or a variety of other digital signals. The ChannelMaster can accept PSK, QPSK, 8PSK, DVB-S, Multi-Level FSK, 16QAM, and COFDM signals directly through the 70 MHz input connector with no internal modifications.

Nucomm also offers a full line of remote control systems, antennas, and antenna mounting equipment that seamlessly integrate with the ChannelMaster series.

See the Nucomm catalog for additional information on the Nucomm website at: www.nucomm.com.

3. SPECIFICATIONS AND FREQUENCY PLANS

RF Performance:

Tuning step size: 250 kHz (*US*), 100 kHz (*International*)

70 MHz input: -10 dBm to 0 dBm (75 Ω)

Frequency stability: ± 5 ppm (.0005%)

Power Output

Standby mode: No RF output

Normal mode: Instant on frequency transmission

HI power = Full power (see Table 3-1)

LOW power = 6 dB drop (*typical*)

Table 3-1 lists band coverage, and maximum power levels for single band configurations.

NOTE: Dual and Tri-band configurations may not support the maximum power level.

Table 3-1: ChannelMaster TX7 Specifications

Base Model	Frequency (GHz)	Band Designator (AA*)	Power Designator (BB*)	Analog Power (dBm)	Digital Power (dBm)
23CMTX7	1.9 - 2.5	23	L5	41	37
			L8	41	39
25CMTX7	2.3 - 2.7	25	L5	41	37
			L8	41	39
nnCMTX7	2.7 - 6.4	Contact Nucomm for specific bands and power levels.			
70CMTX7	6.4 - 7.1	70	B1	33	30
			E1.5	37	32
75CMTX7	7.1 - 7.75	75	B.5	33	27
			E1.5	37	32
82CMTX7	7.7 - 8.5	82	B.5	33	27
			E1.5	37	32
nnCMTX7	8.5 -10.0	Contact Nucomm for specific bands and power levels.			
110CMTX7	10.0 - 10.6	110	C.5	35	27
nnCMTX7	10.6 - 12.7	Contact Nucomm for specific bands and power levels.			
130CMTX7	12.7 - 13.2	130	C.5	35	27
nnCMTX7	13.2 – 15.0	Contact Nucomm for specific bands and power levels.			

* Refer to Section 1.2

Modulation Modes

Modulation 1:	COFDM (DVB-T)
Carriers:	2K
Constellation:	QPSK, 16QAM, 64QAM
Code Rate:	1/2, 2/3, 3/4, 5/6, 7/8
Guard Interval:	1/32, 1/16, 1/8, 1/4
Bandwidth:	6 MHz, 7 MHz, and 8 MHz
Modulation 2:	Analog FM
2 field tunable sub-carriers (optional 4)	
Modulation Deviation (field selectable):	3 MHz/volt or 4 MHz/volt
Modulation 3 (Optional):	VSB
Constellation:	2VSB, 8VSB, 8TVSB (ATSC)
Bandwidth:	6 MHz

MPEG Encoder:**Video**

SD Profile:	MP@ML(4:2:0) 1-15MBPS
.....	422@ML(4:2:2) 3-50MBPS
HD Profile:	MP@HL
	MP@H14L
GOP:	Front panel selectable, (I, IP, IBP, IBBP)
Latency:	Standard (GOP:1-5) ~250mS
	Low Delay(GOP:0) ~90mS
Frame Size:	NTSC:720x480(4:2:0)/720x525(4:2:2)
	PAL:720x576(4:2:0)/720x625(4:2:2)
	720p(1280x720) 59.94,50,29.97,25,23.97Hz
	1080i(1920x1080) 29.97,25Hz
	1080i(1440x1080) 29.97,25Hz
SDI input:	ANSI/SMPTE 259M(SD), 292M(HD)

Audio

Audio Coding:	ISO/IEC 11172-3(Layer II)
Audio Bit Rate:	128, 256kbps, 384kbps
Audio Sample Rate:	48Khz
Audio Channels:	2 Standard (4 Optional)
Audio Input:	Line; Gain selectable (10dB), 600Ω Balanced
	(18dBm = 0dBFS)
	AES/EBU; 150Ω Balanced
	DeEmbedded from SDI; (4 channels)
	Tone; (-10dBfs/8dBm) Level Adjustable (-10 to
	26dBfs)
	Line/Mic; Input range: -4dB and 41dB
	with selectable 10V Phantom Power
Frequency Response:	40Hz – 20KHz: ± 0.5dB
Audio THD:	0.25% @ 1KHz, +8dBm
Signal-Noise:	>70dB

FM Modulator:**Video**

Video:.....	525/625 lines NTSC/PAL field selectable
Composite input:.....	75 Ω , 1Vp-p, NTSC/PAL
SDI input:	ANSI/SMPTE 259M Level C 270Mb/s, 525/626 Component
Video Deviation:.....	1V p-p for \pm 4 MHz deviation 0.75 V p-p for \pm 3 MHz deviation (Selectable)
Video Emphasis:.....	NTSC/PAL/Bypass (CCIR 405)
Video Low Pass Filter:.....	3.9, 4.5, 4.75 and 5.6MHz (Selectable)
Frequency Response:	\pm 0.25 dB (10 Hz to video filter selected)
Base-Band Response:.....	\pm 0.5 dB (10 Hz to 8 MHz)
Signal-to-noise:.....	68 dB (weighted per RS-250C)
Signal-to-Hum:.....	63 dB (weighted per RS-250C)
Differential Phase:	\pm 1.0 degrees
Differential Gain:	\pm 1.0 %

Audio

Audio Channels:	2 tunable subcarriers (4.83 – 9MHz 10KHz steps) 4 optional
Audio Input:.....	Line, Gain selectable (10dB), 600 Ω AES/EBU;, 150 Ω Balanced (0dBFS = +18dBm) DeEmbedded from SDI; (4 Channels) (0dBFS = +18dBm) Tone; 1KHz @ +8dBm adjustable Line/Mic; Input range: -4dB and 41dB with selectable 10V Phantom Power
Audio Deviation:.....	NTSC: 1KHz, +8dBm will deviate \pm 75KHz PAL: 1KHz, +12dBm will deviate \pm 100KHz
Frequency Response:	40Hz – 10KHz: \pm 0.5dB 40Hz – 15KHz: \pm 1.0dB
Audio THD:	0. 5% @ 1KHz, +8dBm
Signal-Noise:	65dB
Emphasis:	50 μ s/75 μ s (Follows Video)

System:

Video Presence: Remote Standby/Test Generator Selectable
Test Generator(Dynamic): SMPTE CB(NTSC)/100% CB(PAL)
16 Character ID(Match SDT Service name
1KHz Tone/Pulse
ASI: Rate converted from 0mpbs-Max modulation
Rate
PCR Retime stamp
Encryption: Optional AES Block Cypher, supporting key
size of 128 and 256bits (FIPS PUB 197)
Mic Phantom Power: 10V Phantom Power output on right XLR conn.
pins 2, 3.

Remote Control:

Electrical Interface: RS232/RS485(2 wire)

Power Requirements:

Input range: AC: 90 to 132VAC, 60 Hz
AC: 180 to 264VAC, 50 Hz
DC: +11 to +32V
Power consumption: 80 W typical (12 watt version)

Environmental Specifications:

Temperature range:
Operating: -30° to +60°C
Storage: -40° to +80°C
Humidity: 0 to 95% non-condensing
Altitude:
Operating: 20,000ft (6,000 m)
Storage: 50,000ft (15,000 m)

Physical Characteristics:

Size (Low Pwr Unit): 4.89" (12.42 cm) x 7.5" (19.05 cm) x
12.0"(30.48 cm)

Size (Hi Pwr Unit): 5.2" (13.21 cm) x 7.5" (19.05 cm) x
12.0"(30.48 cm)

Weight:

Single-Band, No Shroud (typ.): 15.00 lbs (6.80 kg)

Dual-Band, No Shroud (typ.): 16.00 lbs (7.26 kg)

Single-Band, Shrouded (typ.): 15.50 lbs (7.03 kg)

Dual-Band, Shrouded (typ.): 16.50 lbs (7.48 kg)

Tri-Band, Shrouded (typ.): 18.50 lbs (8.39 kg)

Control:

Menu Selection and Entry: Combination Rotary knob/push button

Operating Mode Buttons: Membrane Switches

Connectors:

Video/SDI / DVB-ASI/70MHz: Type BNC-F

Firewire Serial Digital Video Input: IEEE1394 Connector (Optional)

Audio: Multi Pin "MS" Style (XLR break out provided)
XLR Jacks (Optional)

RF Output: Type "N" female

Remote Control: 9 Pin D, Female

Power: Multi Pin "MS" Style

Case:

Ruggedized to withstand rough handling in the field with handles that protect controls from damage. Case is weather-resistant and all connectors are weatherproofed.

3.1 Frequency Plans (USA)

The standard US frequency plans apply to all units sold into markets covered by the FCC. Frequency plans for all systems sold into non-US markets are individualized to meet specific customer requirements and licensing restrictions, as specified at the time of purchase.

2 GHz (17 MHz) (Frequency Range 1,990 MHz – 2,500 MHz)		
Channel	Offset	Receive Frequency MHz
1	–	1,994.75
1	0	1,999.00
1	+	2,003.25
2	–	2,012.25
2	0	2,016.50
2	+	2,020.75
3	–	2,029.25
3	0	2,033.50
3	+	2,037.75
4	–	2,046.25
4	0	2,050.50
4	+	2,054.75
5	–	2,063.25
5	0	2,067.50
5	+	2,071.75
6	–	2,080.25
6	0	2,084.50
6	+	2,088.75
7	–	2,097.25
7	0	2,101.50
7	+	2,105.75
8	–	2,454.25
8	0	2,458.50
8	+	2,462.75
9	–	2,471.00
9	0	2,475.25
9	+	2,479.50
10	–	2,487.50
10	0	2,491.75
10	+	2,496.00

Table 3-2: Frequency Plan (US), 2GHz 17MHz

2 GHz (12 MHz) (Frequency Range 2,025 MHz – 2,500 MHz)		
Channel	Offset	Receive Frequency MHz
1	–	2,028.50
1	0	2,031.50
1	+	2,034.50
2	–	2,040.50
2	0	2,043.50
2	+	2,046.50
3	–	2,052.50
3	0	2,055.50
3	+	2,058.50
4	–	2,064.50
4	0	2,067.50
4	+	2,070.50
5	–	2,076.50
5	0	2,079.50
5	+	2,082.50
6	–	2,088.50
6	0	2,091.50
6	+	2,094.50
7	–	2,100.50
7	0	2,103.50
7	+	2,106.50
8	–	2,454.25
8	0	2,458.50
8	+	2,462.75
9	–	2,471.00
9	0	2,475.25
9	+	2,479.50
10	–	2,487.50
10	0	2,491.75
10	+	2,496.00

Table 3-3: Frequency Plan (US), 2GHz 12MHz

6/7 GHz (25 MHz) (Frequency Range 6,425 MHz – 7125 MHz)		
Channel	Offset	Receive Frequency MHz
1	–	6,881.25
1	0	6,887.50
1	+	6,893.75
2	–	6,906.25
2	0	6,912.50
2	+	6,918.75
3	–	6,931.25
3	0	6,937.50
3	+	6,943.75
4	–	6,956.25
4	0	6,962.50
4	+	6,993.75
5	–	6,981.25
5	0	6,987.50
5	+	6,993.75
6	–	7,006.25
6	0	7,012.50
6	+	7,018.75
7	–	7,031.25
7	0	7,037.50
7	+	7,043.75
8	–	7,056.25
8	0	7,062.50
8	+	7,068.75
9	–	7,081.25
9	0	7,087.50
9	+	7,093.75
10	–	7,106.25
10	0	7,112.50
10	+	7,118.75
11	–	6,431.25
11	0	6,437.50
11	+	6,443.75
12	–	6,456.25
12	0	6,462.50
12	+	6,468.75
13	–	6,481.25
13	0	6,487.50
13	+	6,493.75
14	–	6,506.25
14	0	6,512.50
14	+	6,518.75

Table 3-4: Frequency Plan (US), 6/7GHz

**Table 3-5: Frequency Plan (US),
12/13 GHz**

12/13 GHz (25 MHz) (Frequency Range 12,700 MHz - 13,250.0 MHz)		
Channel	Offset	Receive Frequency MHz
1	-	12,706.25
1	0	12,712.50
1	+	12,718.75
1	++	12,725.00
2	-	12,731.25
2	0	12,737.50
2	+	12,743.75
2	++	12,750.00
3	-	12,756.25
3	0	12,762.50
3	+	12,768.75
3	++	12,775.00
4	-	12,781.25
4	0	12,787.50
4	+	12,793.75
4	++	12,800.00
5	-	12,806.25
5	0	12,812.50
5	+	12,818.75
5	++	12,825.00
6	-	12,831.25
6	0	12,837.50
6	+	12,843.75
6	++	12,850.00
7	-	12,856.25
7	0	12,862.50
7	+	12,868.75
7	++	12,875.00
8	-	12,881.25
8	0	12,887.50
8	+	12,893.75
8	++	12,900.00
9	-	12,906.25
9	0	12,912.50
9	+	12,918.75
9	++	12,925.00
10	-	12,931.25
10	0	12,937.50
10	+	12,943.75
10	++	12,950.00

12/13 GHz (25 MHz) (Con't)		
Channel	Offset	Receive Frequency MHz
11	-	12,956.25
11	0	12,962.50
11	+	12,968.75
11	++	12,975.00
12	-	12,981.25
12	0	12,987.50
12	+	12,993.75
12	++	13,000.00
13	-	13,006.25
13	0	13,012.50
13	+	13,018.75
13	++	13,025.00
14	-	13,031.25
14	0	13,037.50
14	+	13,043.75
14	++	13,050.00
15	-	13,056.25
15	0	13,062.50
15	+	13,068.75
15	++	13,075.00
16	-	13,081.25
16	0	13,087.50
16	+	13,093.75
16	++	13,100.00
17	-	13,106.25
17	0	13,112.50
17	+	13,118.75
17	++	13,125.00
18	-	13,131.25
18	0	13,137.50
18	+	13,143.75
18	++	13,150.00
19	-	13,156.25
19	0	13,162.50
19	+	13,168.75
19	++	13,175.00
20	-	13,181.25
20	0	13,187.50
20	+	13,193.75
20	++	13,200.00
21	-	13,206.25
21	0	13,212.50
21	+	13,218.75
21	++	13,225.00
22	-	13,231.25
22	0	13,237.50
22	+	13,243.75
22	++	13,250.00



4. INSTALLATION

4.1 Unpacking and Inspection

Unpack and visually inspect the unit for any damage to the LCD, connectors, or external surface area damage. All claims should be filed with the carrier. Save all shipping and packing materials for possible re-use.

4.2 Pre-Installation Checkout

Nucomm products are shipped fully tested and calibrated. Should any on-site testing be desired, the following setup is recommended: Connect the ChannelMaster RF output through a 30 watt, 30 dB attenuator to a calibrated spectrum analyzer. Verify the output frequency and level correspond to the transmitter front panel settings within +/- 1dBm.

4.3 Mechanical Installation

The unit ships pre-assembled and requires no mechanical installation other than cabling.



The base of the unit has one large tripod screw that is centered on the underside of the system. A second, smaller tripod screw towards the rear can also be used. The base also has six holes for mounting screws that can be used to attach the unit from the underside. The locations of the screw holes are shown in Figure 4-2.

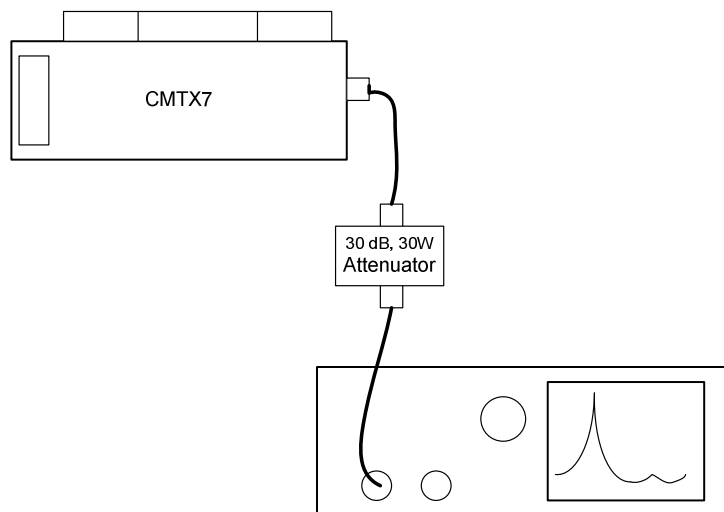
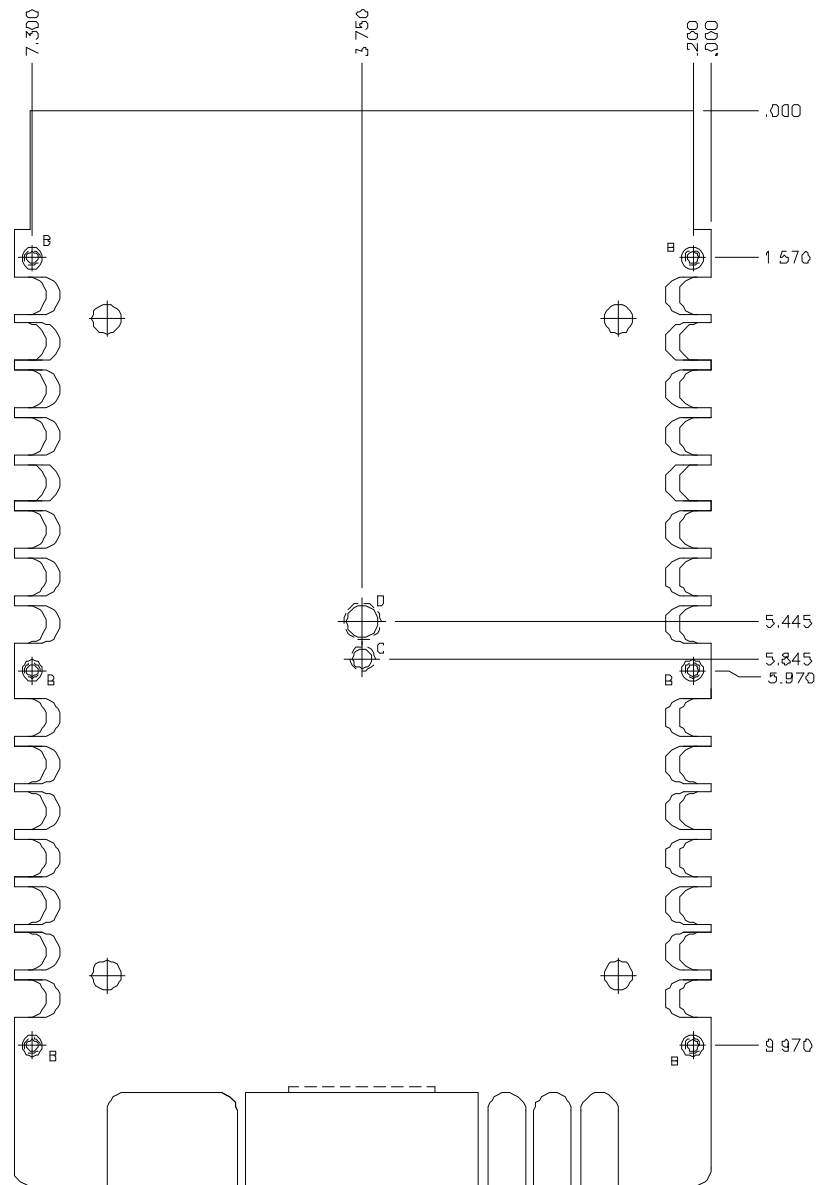

Figure 4-1: Pre-Installation Checkout Equipment Configuration



Hole	Screw Size	Screw Length (Max)	Quantity
B	1/8-32	0.3"	6
C	1/4-20	0.35"	1
D	3/8-16	0.375"	1

Figure 4-2: CMTX7 Mounting Hole Locations and Screw Sizes

The unit has a large heatsink on its top surface. This area requires clearance from other objects while using the unit within the unit's normal operating air temperature range.

Some units have a shroud covering the heatsink. (see Figure 4-3). The shroud includes two built in cooling fans (see figure 4-4).



Figure 4-3: CMTX7 Unit with Shroud

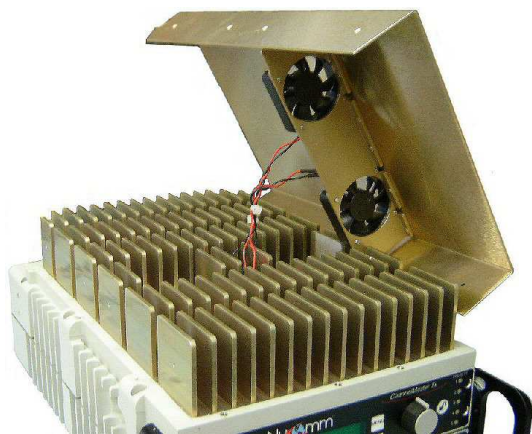

Figure 4-4: CMTX7 Unit with Shroud (Shows Built-in Cooling Fans)

4.4 Electrical Installation

The unit front and back panels are shown in Figure 4-5 thru Figure 4-7.

4.5 Power Connection

The built-in power supply accepts these input voltages without requiring any jumper or switch settings:

- 90 to 132VAC, 60 Hz
- 180 to 264VAC, 50 Hz
- +11 to +32VDC

The power input is labeled ① in Figures 4-5 and 4-6. The Power Pin-Outs and Cable are illustrated in Figures 4-8 and 4-9. See Chapter 3 for the Power Supply Specifications.

Nucomm ships a DC cable and the appropriate local AC line cord. Alternate line cords are available upon request.

Optional "Standby" Power feature:

For power redundancy, the unit can be configured to accept both AC **AND** DC.

4.6 ASI, SDI, Composite & 70MHz Ports

All video inputs are made via 75 Ω BNC coaxial cables to the appropriate, clearly marked, front panel port. See Figures 4-5 and 4-6.

ASI and SDI Inputs can be SD (NTSC or PAL) or HD Video transport streams. ASI (to 31.66845 Mbps) or SDI signals are input via the *ASI IN* or *SDI IN* ports; see ② and ③ .

Composite or Baseband video can be input via *VIDEO IN* ⑤ . Note: On units without a marked *SDI IN* port, SDI is input via the *VIDEO IN* port.

70 MHz is input via the *70 MHz IN* port. ^④

Select the appropriate input type via the front panel user interface. See Section 5 for details.

An optional *ASI OUT* port enables use of the CMTX7 as a standalone ASI (MPEG2) encoder. ^⑩

4.7 RF OUTPUT



RF output is via a Type-N connector at the rear of the unit ^⑪ (See Figure 4-7). Directly connect a suitable antenna, or a 50 Ω , low-loss coaxial cable (*such as RG-214U*) between the RF Output and the antenna connector.

4.8 Serial Port

The RS232/RS485 connector on the left side of the unit is used for remote control and monitoring of the system. See Figure 4-10. Serial data for remote control is also available on the front panel power connector. See Figure 4-8.

4.9 POWER SWITCH and FUSES

The unit has a power switch ^⑫ and AC & DC fuses on the rear. The AC fuse is 2.5 Amps (*fast blow*). The DC fuse is 10 Amps (*fast blow*). Refer to Figure 4-7.

4.10 Models with Multi-Pin “MS” Style Audio Connectors

On models with multi-pin connectors, all audio inputs are connected using a

multi-pin plug ^⑥ and two or four XLR breakout cables (provided). See Figures 4-12 and 4-13.

4.11 Models With XLR Audio Connectors

On models with XLR Audio Connectors, audio inputs are connected via the front panel XLR jacks ^⑦. Models with 3 pin XLR jacks have 2 audio inputs; models with 5 pin XLR jacks have 4 audio inputs.

Phantom power is available on the right XLR connector and can be activated through the user menu to power microphones requiring this feature when desired. See Figure 4-14.

4.12 Firewire

The CMTX7 front panel has an IEEE1394 Firewire video ^⑨ for connecting a video camera Firewire digital video output. See Figure 4-11.

Contact Nucomm for availability of this feature.

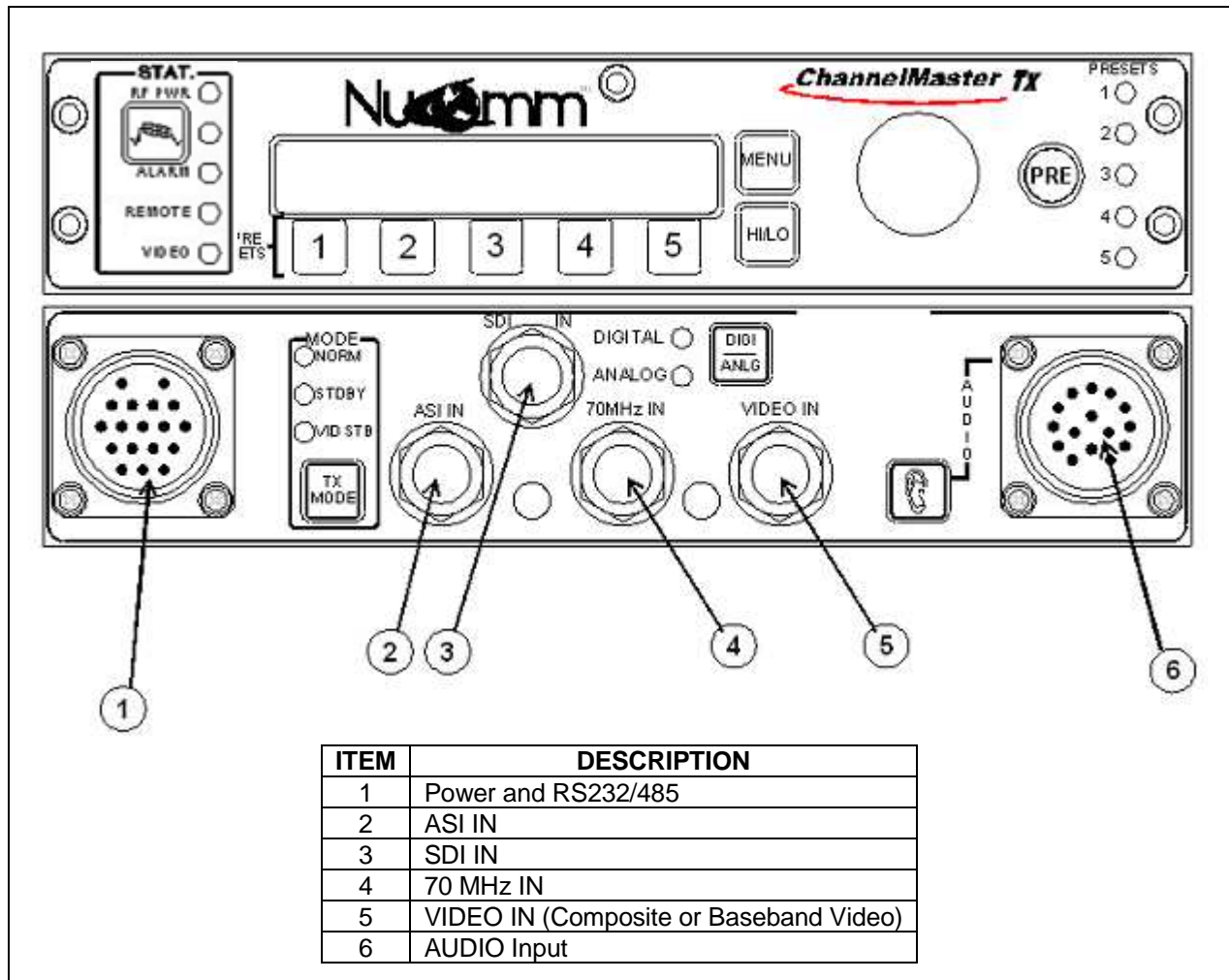

Figure 4-5: ChannelMaster TX7 Front Panel (Mil Connector Version)

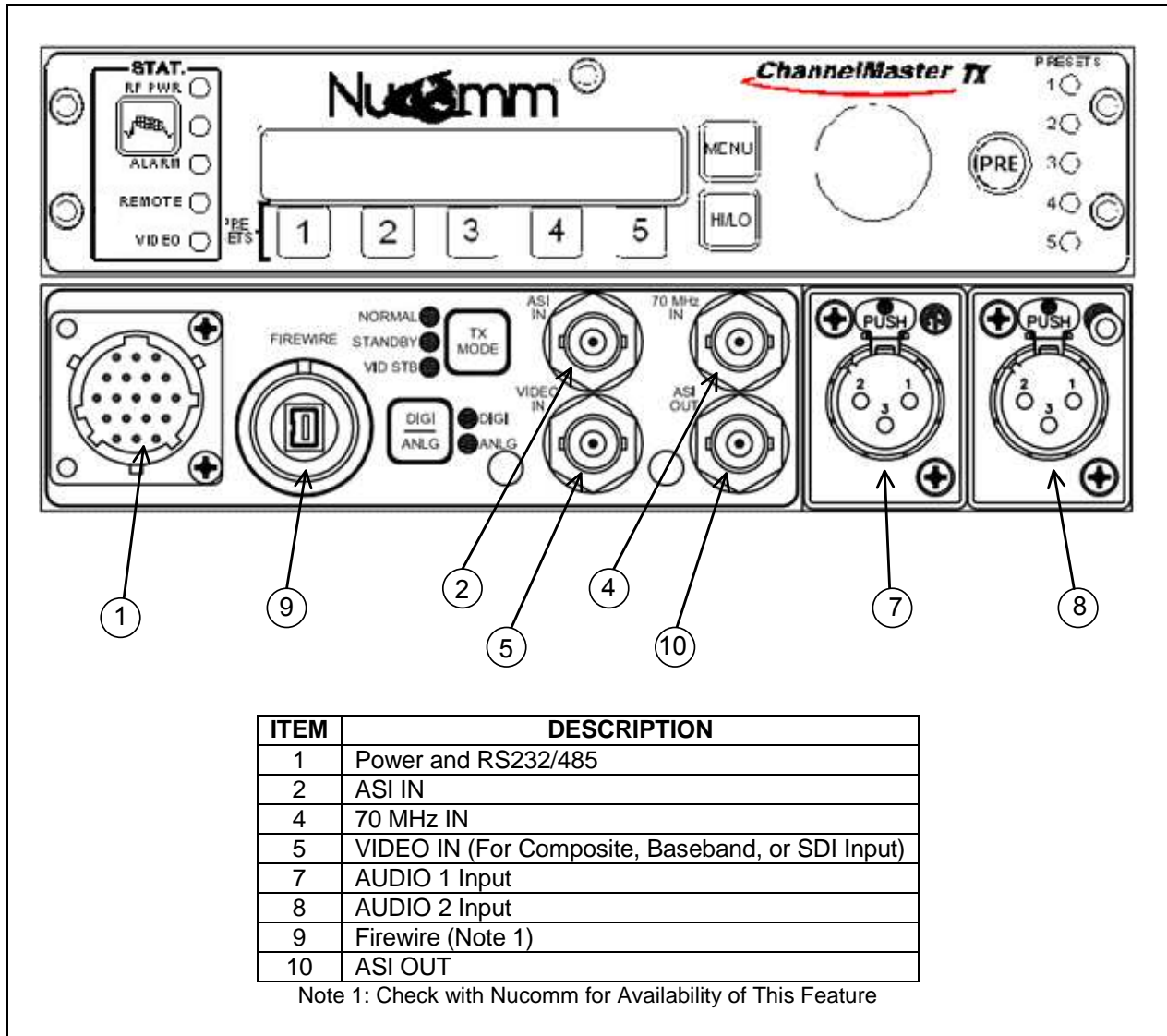

Figure 4-6: ChannelMaster TX7 Front Panel (XLR Version)

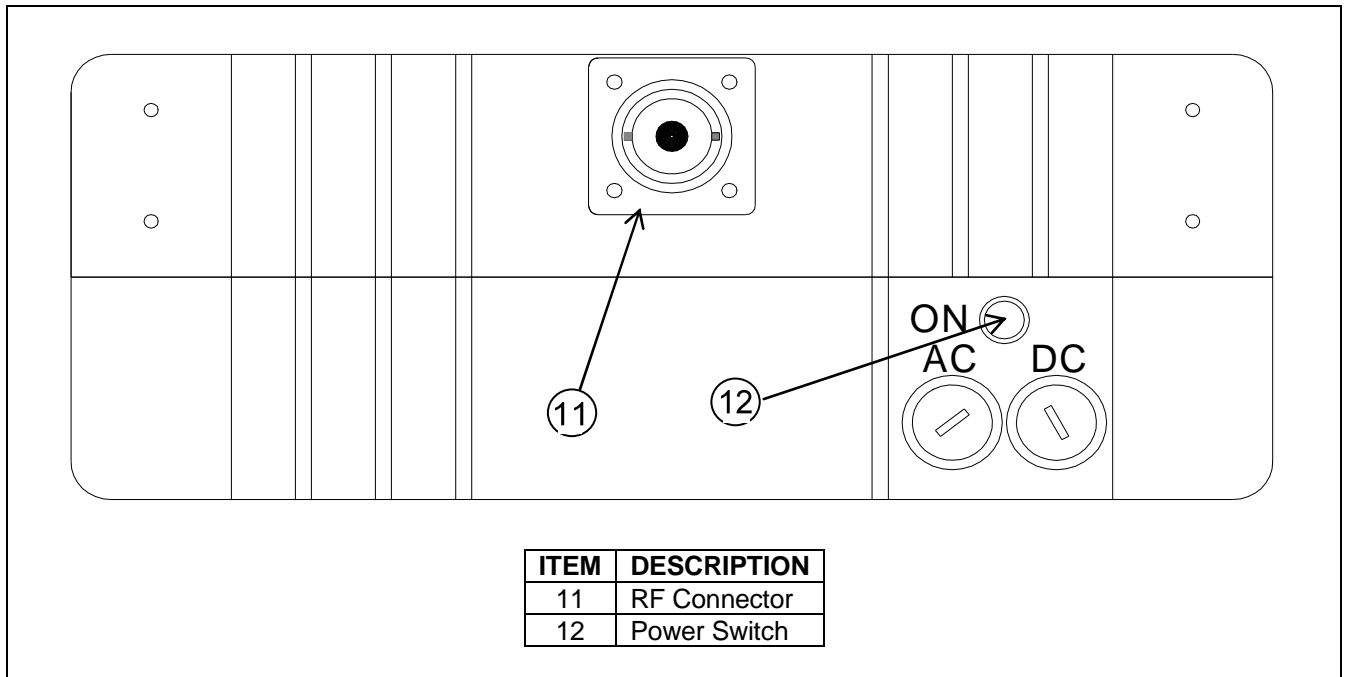
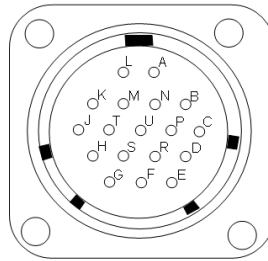

Figure 4-7: ChannelMaster TX7 Rear Panel (All Models)



CMTX7 Front Panel Power Connector	Mating Connector
Nucomm P/N: 512-M2001-000	Nucomm P/N: 512-F3001-000
Detronics P/N: DT02H-14-18PN	Mil-C-26482, Series 1 P/N: MS3116F-14-1PS

PIN	DESCRIPTION	NOTES
C	AC Neutral	
E	Chassis GND	Connected to Chassis and Pins H and S internally.
G	AC Line	
H, S	GND (DC GND RETURN)	Connected to Internal DC ground, Pin E, and Chassis internally.
P, U, B	+DC IN	DC power
M	RS232 TX / OUT	For Remote Control
L	RS232 RX / IN	For Remote Control
SHELL	Chassis GND	(Can be used to shield power cables.)

Figure 4-8: Power and RS-232 Connector Pin-Outs and Part Information

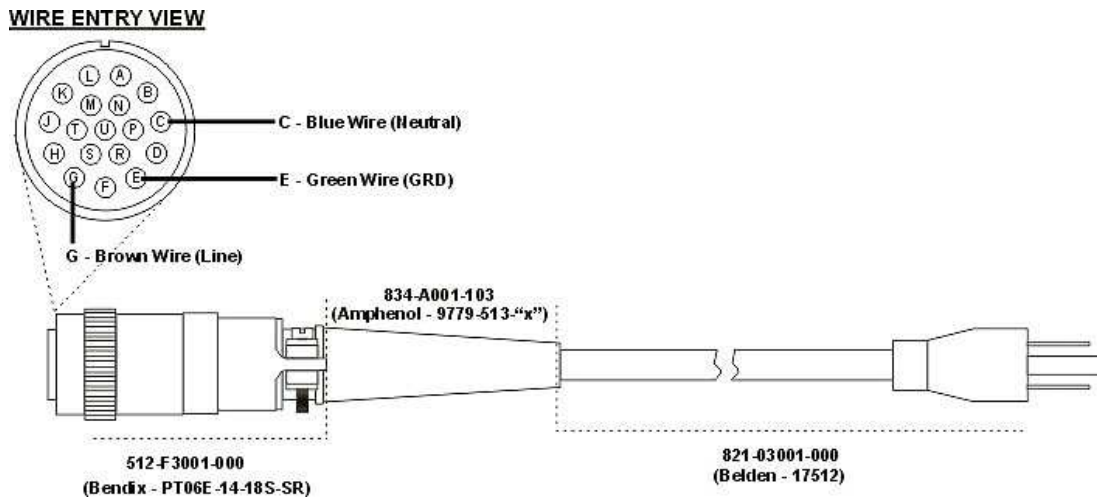

Figure 4-9: AC Line Cord Construction

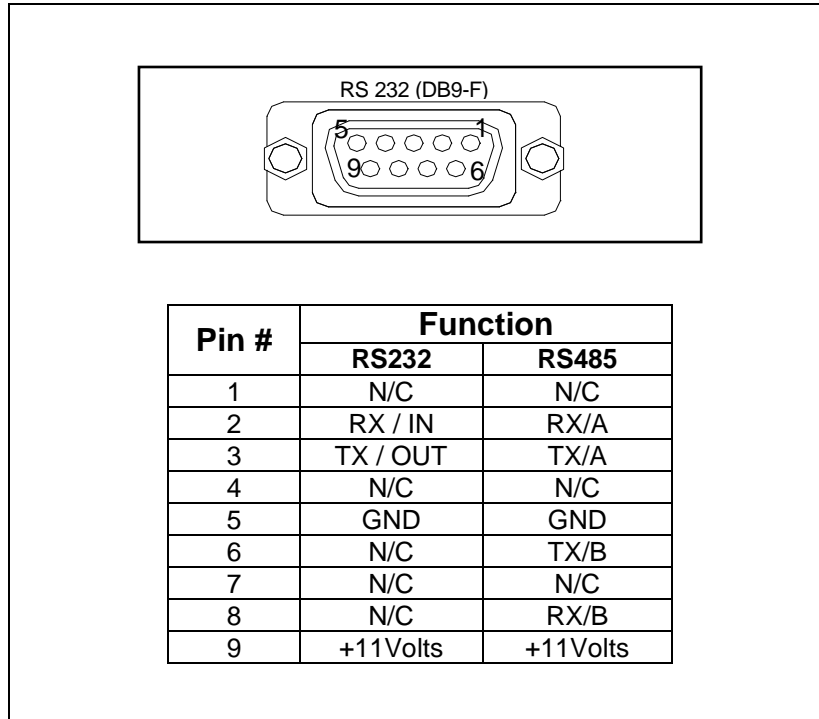
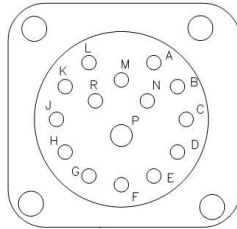

Figure 4-10: RS232/RS485 Connector Pin-Outs



Figure 4-11: Firewire Input Connector (Optional)
 (Contact Nucomm for availability of this option.)



CMTX7 Front Panel Connector	Mating Plug
Nucomm P/N: 512-M2014-015 Detoronics P/N: DT02H-14-15PN	Nucomm P/N 512-F3012-015 Mil-C-26482, Series 1 P/N: MS3116J-14-15S

CM Transmitter Audio Cable			
CM Transmitter 17-Pin Audio Connector PIN-OUT	XLR PIN-OUT	XLR Signal	DESCRIPTION
J	2	A1+	Analog1/AES1
H	1	A1 GND	Analog1/AES1 Ground
G	3	A1-	Analog1/AES1
M	2	A2+	Analog2
L	1	A2 GND	Analog2 Ground
K	3	A2-	Analog2
F	2	A3+	Analog3/AES2
E	1	A3 GND	Analog3/AES2 Ground
D	3	A3-	Analog3/AES2
C	2	A4+	Analog4
B	1	A4 GND	Analog4 Ground
A	3	A4-	Analog4
I	-	-	Not Connected
SHELL	SHELL	SHELL	Earth (Chassis) Ground

Figure 4-12: Audio Cable Connections

WIRE ENTRY VIEW

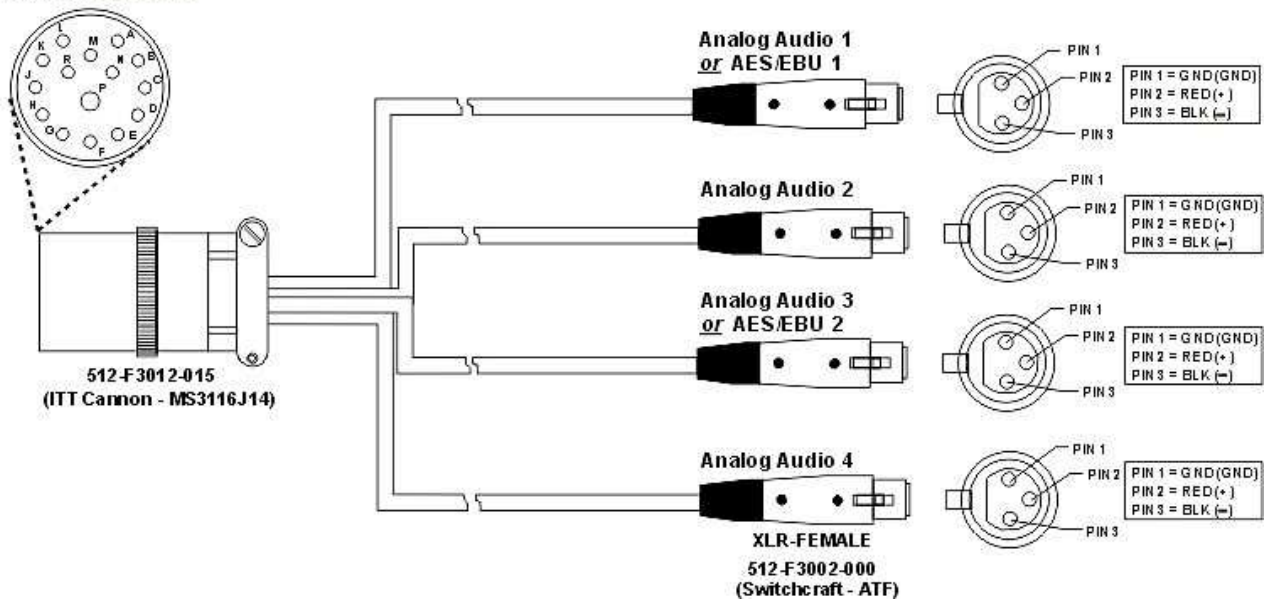

Figure 4-13: XLR Breakout Cable

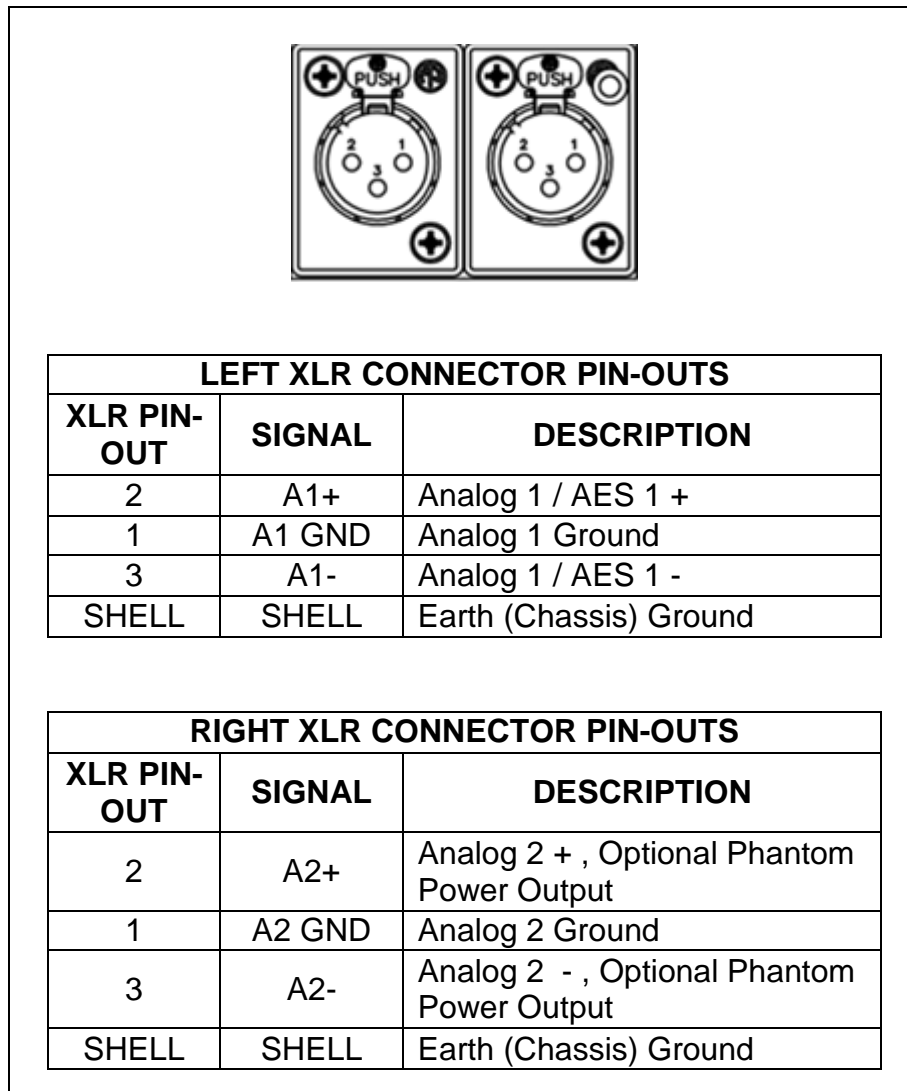

Figure 4-14: 3-PIN XLR Input Pin Assignments (2 Audio Inputs)

5. OPERATION

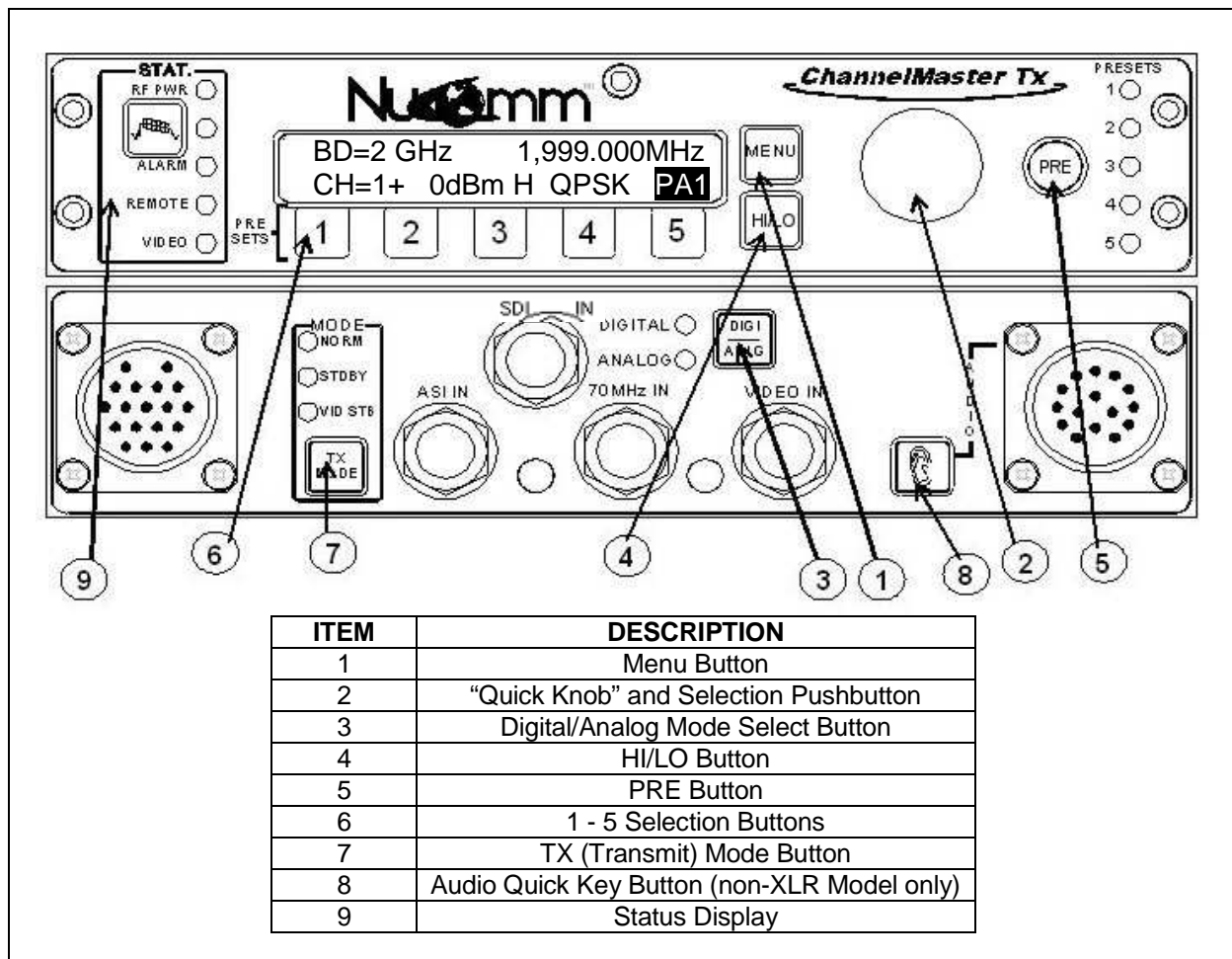
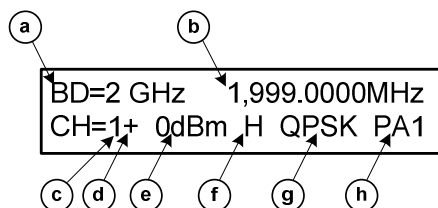

Figure 5-1: ChannelMaster TX7 Front Panel Controls and Indicators

5.1 Power Up Displays

Upon powering up the unit, you will see three quick screens showing the equipment type, the model number, and the serial number. After that, the unit will display the DEFAULT screen, which will look similar to the following (*depending on your configuration*).



The DEFAULT screen displays:

- (a) The current **Frequency Band**
- (b) The current **Channel Frequency**
- (c) The current **Channel**
- (d) The current channel **Offset**
- (e) The **RF Output Level** in dBm
- (f) The current **Power Level** (HI / LO)
- (g) The current **Modulation Type**
- (h) The current **Preset** selected (if any)

Once this screen appears, options and settings can then be changed and initialized through the use of the front panel "Quick-Keys" and pre-set buttons, via the menu system, or by making selec-

tions from the default screen with the Quick Knob.

System navigation is via the rotary "Quick Knob" switch ^② (See Figure 5-1) to the right of the LED display. Turn the "Quick Knob" clockwise or counter-clockwise to move the cursor through the DEFAULT screen selections or the menus. By pressing the "Quick Knob", you are able to select or activate items. The "Quick Knob" may also be referred to as the "Enter" button or "the Wheel."

5.1.1 Changing Characters

1. Begin by rotating the "Quick Knob" until the desired screen item is highlighted. Press Enter to select the item.
2. The left-most character position of the name will then be highlighted. Rotate the "Quick-Knob" until the desired alpha-numeric character appears.
3. Press the "Quick-Knob" to save the character.
4. Move the cursor to the second character by rotating the "Quick-Knob".
5. Press the "Quick-Knob" to select the character.
6. Rotate the "Quick-Knob" until the desired alpha-numeric character appears.
7. Again, Press the "Quick-Knob" to save the character.
8. Repeat Steps 2 thru 7 until either the desired name is assigned or all character positions are filled.

On certain screens (as with system settings), an arrow is used to show the current setting, as in the following where "SDI" is currently set:



Note the highlighted arrow at the bottom left of the screen. This highlighting is the "cursor", and indicates an item that is ready to be selected.

Note: After one minute of inactivity the display reverts to the DEFAULT screen, and any un-activated selections are discarded.

5.2 Front Panel Buttons

Modulation Mode ^③

The ChannelMaster modulation mode is set to ANALOG or DIGITAL using the "DIGI/ANLG" Button.



Pressing the "DIGI/ANLG" Button toggles the ChannelMaster between Digital and Analog modulation modes. An LED and a confirmation message indicate that the mode change is being made.



Switching to Digital Mode



Switching to Analog Mode

Set Power Level ^④

The user can toggle between HI or LOW power by pressing the “**HI/LO**” Button.



The LCD will then immediately display the change.

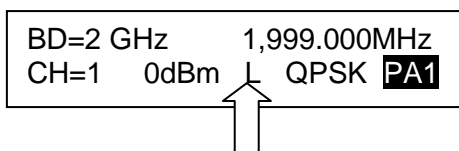

Unit in Low Power Mode

5.2.1 Changing Operating Frequency

(Requires Frequency Direct Mode. See Sec. 5.9.1.)

1. Ensure that the Main Menu screen is displayed on the LCD.
2. Rotate the “Quick-Knob” to highlight the preset parameter to be changed.
3. Press the “Quick-Knob” to enter the selection.
4. Rotate the “Quick-Knob” to adjust the value of the selection.
5. Press the “Quick-Knob” to enter the changed value.
6. Rotate the "Quick Knob" until the digit that needs to be changed is highlighted.

7. Press "Enter".
8. Change the digit as needed.
9. Press "Enter".
10. Repeat until all digits are correct.
11. When all digits are correct, move the cursor to the end of the frequency where it says “GHz”.
12. Press "Enter".

When the operating frequency is changed, the unit goes into standby while the synthesizer re-tunes to the new frequency. Transmission resumes when the new frequency is reached.

Note: If offset channel operation is desired, the user is cautioned to ensure they have adequate authorized spectrum to avoid illegal operation. For example, in the US post-Nextel 2 GHz band plan, which stipulates 12 MHz channels with 3 MHz offsets, use of 7 MHz or 8 MHz modulation bandwidths on an offset channel would result in out of channel emissions and potential adjacent channel interference. Thus, for this example, 6 MHz modulation bandwidth should be used when using offset channels with Channels 1-7 in the US 2 GHz post-relocation band plan.

5.3 Using Presets

There are 15 user definable Presets. These Presets are accessed using the numbered “Preset” Buttons, ^⑥ **or** through the “*PRE*” Button. ^⑤

The numbered Preset Buttons (1 through 5) are located just below the LCD. These five numbered preset keys are provided to rapidly store and recall custom configurations without requiring any menu navigation.

There are three banks of Presets: Pa1-Pa5, Pb1-Pb5, and Pc1-Pc5.



Pa1 through Pa5 may be accessed by simply pressing the Preset (1-5) buttons. The other two sets of presets are only accessible through the *PRE* (Preset) Button.



“PRE” Button

The “PRE” button toggles between the three banks of presets. Pressing the “PRE” Button once brings up the presets pa1 – pa5.



Pressing the “PRE” Button twice, brings up the presets pb1 – pb5.

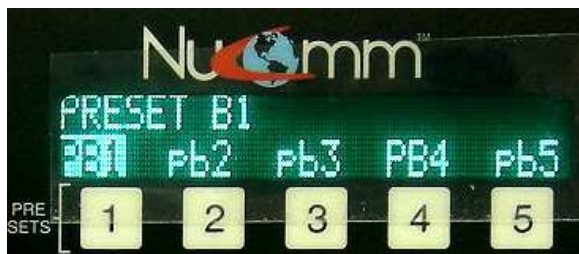

Pressing the “PRE” Button three times, brings up the presets pc1 – pc5.



Saving Presets

Before saving a preset, program the radio with the desired parameters. (Refer to Section 5.2.1 or 5.5.)

To Save Your Settings:

For Presets pa1 – pa5, simply press & hold the desired numbered button until the confirmation message is displayed (approximately 4 seconds).



Press & hold numbered button below the desired preset to save it.

For Presets pb1 – pb5, & pc1 – pc5, press the “PRE” Button the appropriate amount of times to bring up the desired set. Rotate the “Quick-Knob” to highlight the desired preset. Press & hold the appropriate numbered key until the confirmation message is displayed (approximately 4 seconds).

When a preset is saved, all system parameters are stored into memory with the associated preset. These parameters include:

- Modulation Parameters
- Input Type
- Power Mode
- Channel Number & Frequency
- Audio Settings

All presets represented by *uppercase letters* have been programmed. All presets represented by *lowercase letters* have not been programmed.

Example:

- PA1 - **has** been programmed.
- pa1 - **has not** been programmed.

Setting & Changing Preset Name

Each preset can be given a name up to 16 characters long. The name can consist of alpha-numeric characters only (*characters A – Z & 1 – 9*). The preset must be saved before it can be assigned a name.

To assign a preset name:

1. From any menu screen, toggle the “PRE” Button to bring up the set containing the desired preset.
2. Rotate the “Quick-Knob” to highlight the preset to be named.
3. Press the “Quick-Knob” to select the Preset.
4. Rotate the “Quick-Knob” until the name area is highlighted.
5. Press the “Quick-Knob” to begin editing. (Refer to Section 5.1.1 for **Changing Characters**.)



Highlighted Name Area

6. When finished, move the cursor over the arrow at the bottom-right.

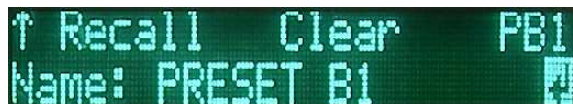

7. Press the “Quick-Knob” to select the arrow. The name has now been saved.

Recalling A Preset

Briefly press the desired Preset button to recall settings.

When PA1-PA5 have been recalled, the associated Preset LED will illuminate.



Preset 1 Active

NOTE: If the unit is enabled for **Preset Lock RF CHN**, the frequency cannot be changed by a preset and will remain the current operating channel.

Clearing all Presets

Pressing and holding the “1” and “3” buttons simultaneously brings up the following dialog:

Clear All Presets?: Yes? No?

Caution: Selecting “YES” will clear all presets in the radio.

TX MODE

The **TX MODE** button is used to select from the following operating modes:

- **NORMAL:** Transmitter is active, with or without an input signal.
- **STANDBY:** Transmitter is in STANDBY until switched to another mode. Frequency synthesizer is locked on frequency.
- **VID STBY:** Controls the transmitter behaviour when a signal is not detected on the input port. The system can be set to either go to Standby or transmit the internally generated test bars.



AUDIO Quick Key ⁸

The AUDIO quick key provides a shortcut to the audio settings. (Note: the Audio button is not present on the optional XLR front panel.)

When modulating digitally, the system will display the Encoder's audio settings as if you had selected the following menu items: **Menu>Encoder>Audio**. (Refer to Section 5.5; **Encoder Menu Selections**.)

When modulating in analog, the system displays the FM audio settings, as if the following items were selected: **Menu>Modulation>Parameters>FM>Audio**. (Refer to Section 5.5; **FM**.)



5.4 Status Indicators & Test Gen

The following show the unit's status:

RF (Green): RF present at output port.

Test Gen LED (Amber): Color Bars are active.

Alarm (Red): Indicates an improper setting or a module failure. The exact reason for the alarm can be determined from the Alarm section of the Main Menu.

Remote: Unit is under remote control.

Video (Green): Indicates that video is present.



TEST GEN

This button toggles the internal color bars "on" and "off," and allows editing of the 16 character ID, as well as selection of the tone levels. TEST GEN may only be selected when the input type is set to COMPOSITE or SDI.

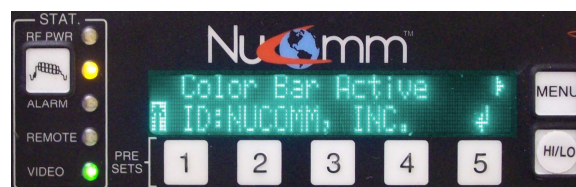

When TEST GEN is enabled, the LED will light and the LCD will display the screen shown above. The ID can be edited from this screen.

To modify the TEST TONE levels, scroll the wheel to the right twice and the TONE LEVEL screen will appear. The tone levels can be set from -26dBFS to -10dBFS.

When the TEST TONE is “on,” the left channel contains a continuous tone and the right channel has a pulsing tone.

5.5 Main Menu Selections

The user can customize the Channel-Master TX7 operation (*rather than using the factory defaults*) through the Main Menu. After pressing the *MENU* Button ①, the Main Menu Screen will appear.



From the **Upper Level Menu**, the user can select one of six sub-menus to access. They are:

- **Input Menu**
- **Modulation Settings Menu**
- **Encoder Settings Menu**
- **System Settings Menu**
- **Monitoring Menu**
- **Alarms**



5.6 Input Menu Selections

The **Input Menu** selections are dependent on whether the unit is set for Analog or Digital modulation (Section 5.2).

Only one input can be made active at a time. The Input Menu controls the active input, regardless of any signals present on the input connectors.

When digital modulation is selected, the available input selections are:

Composite - The signal is converted to digital via the MPEG Encoder and routed to the digital modulator.

SDI - The signal routes through the MPEG Encoder and then to the digital modulator.

External 70 MHz Digital - This input bypasses the encoder and modulator, and routes to the heterodyne up-converter.

ASI - Input bypasses the Encoder and goes to the digital modulator. (*The ASI rate must be at or below the maximum digital modulation rate.*)

Firewire – The MPEG2 data is extracted and sent to the digital modulator.

When analog modulation is selected, the available input selections are:

Composite - The composite signal is routed through the internal low pass filter (*bandwidth ± 4.0 MHz NTSC, ± 5.6 MHz PAL typical*) then sent to the FM modulator.

Note: To input Baseband video, set the video filter to “Bypass.” See sec. 5.7.1.

SDI - Internal circuits convert SDI inputs to Composite. The signal is then processed as Composite.

External 70 MHz FM - This input bypasses the modulator, and routes to the heterodyne up-converter.

5.7 Modulation Menu Selections

The **Modulation Menu** establishes the operating parameters for both Analog and Digital modulation schemes. The Modulation Menu has two sub-menus:

- **Mode Select**
- **Parameter Setup**

Mode Select is used strictly for selecting the type of **Digital Modulation** to be utilized. Choices are COFDM, **DVB-S**, and VSB.

Parameter Setup allows the user to change or adjust the various parameters affecting the different modulation types:

- **FM**
- **COFDM**
- **DVB-S (Future)**
- **VSB**

5.7.1 FM

For FM (i.e. *Analog FM Modulation*), there are two sub-categories: Audio, and Video.

AUDIO



Under the FM **Audio** sub-menu, the user can choose between any one of four Analog audio channels (**SC1L**, **SC1-R**, **SC2-L**, & **SC2-R**) and change any of the following:

- **Input:** *Off, Line/Line, Line/Mic, Line/Mic+PP, Tone, AES/EBU, and Embedded*
- **Insertion:** *Adjusts from -40 dB to -20 dB; (default -28 dB.)*
- **Gain:** *Adjusts from -6 dB to $+6$ dB; (default 0.0 dB)*
- **Frequency:** *Adjusts sub-carrier frequency. (Refer to table in Section 5.7.1. **Audio Sub-carrier Frequencies.**)*

If **Line/Line** is selected, the unit accepts balanced $600\ \Omega$ inputs at $+8$ dBm Analog (-10 dBu Digital). At 1 kHz input, headroom is $+18$ dBm Analog (0 dBu Digital).

If **AES** is selected, the unit accepts digital AES audio on Audio 1 (*and Audio 3 in a four audio unit*). If only two audio channels are configured, they will be the first channel in Group 1.

If **Embedded** is selected, the audio data embedded in the incoming SDI stream will be used. This selection will only be available when SDI input is selected.

A 1 kHz **Tone** can be activated. The tone is steady on the left channel, and intermittent on the right channel.

When **Line/Mic** is selected, the unit is set to accept a line input on the left connector, and input from a microphone on the right connector. The microphone input range is -4dB to +41dB. This option is only available on models with front panel XLR inputs.

When **Line/Mic+PP** is selected, the unit is set to accept a line input on the left connector, and input from a microphone on the right connector. Phantom power is output on pins 2 and 3 of the right connector to power the microphone. The microphone input range is -4dB to +41dB. This option is only available on models with front panel XLR inputs.

VIDEO



Under the FM **Video** sub-menu, the user can change any one of four selections. They are:

- **Inverse:** *Normal, Inverse*
- **Emphasis:** *Emphasis, Flat*
- **Filter:** *Bypass, 3.90 MHz, 4.50 MHz, 4.75 MHz, 5.60 MHz. (In PAL mode only 5.60 MHz and Bypass are available.)* The filter setting allows you to groom the incoming video signal bandwidth. Setting the filter to bypass allows for input of Baseband video.
- **Deviation Bandwidth:** *(Display Only)*

5.7.2 COFDM



For the **COFDM** (*Digital*) sub-menu, the following parameters can be changed:

- **Power:** *On, Off*
- **Constellation:** *QPSK, 16QAM, 64QAM*
- **Code Rate (error correction):** *1/2, 2/3, 3/4, 5/6, 7/8*
- **Guard Interval (guard spacing - delay between intervals):** *1/32, 1/16, 1/8, 1/4.*
- **Bandwidth:** *6 MHz, 7 MHz, 8 MHz*

Note: Adjusting these settings modifies the data rate.

COFDM Guidelines

The COFDM Data Rate is determined by manipulating Guard Interval, Code Rate, Bandwidth and Constellation, per the COFDM Data Rate tables in Section 5.7.

As a rule of thumb, select the COFDM parameters in this order:

1. Use the lowest data rate required to pass the necessary data.
2. Use the maximum Bandwidth allowed by your spectrum manager(s).
3. Choose the minimum Constellation (i.e. Modulation System) setting that will allow the data rate required. For example, don't use 16QAM if enough data can be transmitted using QPSK.
4. Adjust the GI (Guard Interval) and CR (Code Rate).
 - (a) The GI, or "safety bits", help allow COFDM to operate in mul-

tipath environments (around buildings, across water, etc) by increasing the time delay between data segments. Increasing the GI (1/4 is the maximum setting) increases link robustness but reduces the overall data rate, as less time is made available for payload transmission. Conversely, moving the GI towards 1/32 (the minimum) decreases link robustness but allocates more bits to payload.

(b) The CR controls how much error correction overhead is included in the data stream. To compensate for a poor link, moving the CR towards 1/2 (maximum error correction)

increases link robustness as bits are re-allocated from payload to error correction. Moving the CR towards 7/8 (minimum error correction) allocates bits from error correction to payload.

COFDM Data Rate

Tables 5-1 through 5-3 show the data rates which can be achieved by modifying the COFDM parameters.

Note: When inputting ASI signals, the data rate should be set to approximately 1-2 kbps above the ASI input rate.

Table 5-1: ChannelMaster 8 MHz B/W Data Rates

Modulation System	Code Rate	Guard Interval			
		1/32	1/16	1/8	1/4
IF = 9.142857 MHz Clk=36.571429 Mbit/s		Flo = 60.857143 MHz		BW = 8 MHz	
Data Rate (Mbit/s)					
QPSK	1/2	6.032086	5.854671	5.529412	4.976471
	2/3	8.042781	7.806228	7.372549	6.635294
	3/4	9.048128	8.782007	8.294118	7.464706
	5/6	10.053476	9.757785	9.215686	8.294118
	7/8	10.55615	10.245675	9.676471	8.708824
16-QAM	1/2	12.064172	11.709342	11.058824	9.952942
	2/3	16.085562	15.612456	14.745098	13.270588
	3/4	18.096256	17.564014	16.588236	14.929412
	5/6	20.106952	19.51557	18.431372	16.588236
	7/8	21.1123	20.49135	19.352942	17.417648
64-QAM	1/2	18.096258	17.564013	16.588236	14.929413
	2/3	24.128343	23.418684	22.117647	19.905882
	3/4	27.144384	26.346021	24.882354	22.394118
	5/6	30.160428	29.273355	27.647058	24.882354
	7/8	31.66845	30.737025	29.029413	26.126472

Table 5-2: ChannelMaster 7 MHz B/W Data Rates

Modulation System	Code Rate	Guard Interval			
		1/32	1/16	1/8	1/4
IF = 7.999999875 MHz Clk=32.0000 Mbit/s		Flo = 62.000000125 MHz		BW = 7 MHz	
Data Rate (Mbit/s)					
QPSK	1/2	5.27807525	5.12283713	4.8382355	4.35441213
	2/3	7.037433375	6.8304495	6.45098038	5.80588225
	3/4	7.917112	7.68425613	7.25735325	6.53161775
	5/6	8.7967915	8.53806188	8.06372525	7.25735325
	7/8	9.23663125	8.96496563	8.46691213	7.620221
16-QAM	1/2	10.5561505	10.2456743	9.676471	8.70882425
	2/3	14.07486675	13.660899	12.9019608	11.6117645
	3/4	15.834224	15.3685123	14.5147065	13.0632355
	5/6	17.593583	17.0761238	16.1274505	14.5147065
	7/8	18.4732625	17.9299313	16.9338243	15.240442
64-QAM	1/2	15.83422575	15.3685114	14.5147065	13.0632364
	2/3	21.11230013	20.4913485	19.3529411	17.4176468
	3/4	23.751336	23.0527684	21.7720598	19.5948533
	5/6	26.3903745	25.6141856	24.1911758	21.7720598
	7/8	27.70989375	26.8948969	25.4007364	22.860663

Table 5-3: ChannelMaster 6 MHz B/W Data Rates

Modulation System	Code Rate	Guard Interval			
		1/32	1/16	1/8	1/4
IF = 6.85714275 MHz Clk=27.428571 Mbit/s		Flo = 63.14285725 MHz		BW = 6 MHz	
Data Rate (Mbit/s)					
QPSK	1/2	4.5240645	4.48248248	4.2334561	3.81011061
	2/3	6.03208575	5.854671	5.5294118	4.9764705
	3/4	6.786096	6.58650525	6.2205885	5.5985295
	5/6	7.540107	7.31833875	6.9117645	6.2205885
	7/8	7.9171125	7.68425625	7.2573533	6.531618
16-QAM	1/2	9.048129	8.7820065	8.294118	7.4647065
	2/3	12.0641715	11.709342	11.058824	9.952941
	3/4	13.572192	13.1730105	12.441177	11.197059
	5/6	15.080214	14.6366775	13.823529	12.441177
	7/8	15.834225	15.3685125	14.514707	13.063236
64-QAM	1/2	13.5721935	13.1730098	12.441177	11.1970598
	2/3	18.0962573	17.564013	16.588235	14.9294115
	3/4	20.358288	19.7595158	18.661766	16.7955885
	5/6	22.620321	21.9550163	20.735294	18.6617655
	7/8	23.7513375	23.0527688	21.77206	19.594854

5.7.3 VSB



The following parameters can be changed using the **VSB** sub-menu:

- **Type:** 2VSB, 8VSB, 8TVSB
- **Bandwidth:** 6 MHz

Table 5-4: VSB Data Rates at 6MHz

VSB	Data Rate (Mbit/s)
2VSB	9.696329
8TVSB*	19.392658
8VSB	29.088987

*The ATSC standard is 8TVSB at 6MHz.

5.8 Encoder Menu Selections

The **Encoder Menu** sets the MPEG 2 parameters, and has four sub-menus:

- **Audio**
- **Video**
- **Service**
- **Mux**

5.8.1 AUDIO



Under the **Audio** sub-menu, the user can modify parameters for Digital Audio Channel 1 and Digital Audio Channel 2 (if active).

- **Input:** *Off*, *Line/Line*, *Line/Mic*, *Line/Mic+PP*, *Tone*, *AES/EBU*, and *Embedded*
- **Sample Rate:** (Per Display)
- **Level (L):** *Adjusts left-side input level from -6 dB to +6 dB; (default 0.0 dB)*
- **Level (R):** *Adjusts right-side input level from -6 dB to +6 dB; (default 0.0 dB)*

The digital audio gain adjustment allows for ± 6 dB of gain, and can be used to compensate for variance in line and microphone input levels.

If **AES** is selected, the unit accepts digital AES audio on Audio 1 (and Audio 3 in a four audio unit) and sends it to the MPEG encoder. If only two audio channels are configured, they will be the first channel in Group 1.

If **Embedded** is selected, the audio channels embedded in the incoming SDI stream will be used.

A 1 kHz **Tone** can be activated. The tone is steady on the left channel, and intermittent on the right channel.

If **Line/Mic** is selected, the unit is set to accept a line input on the left connector, and input from a microphone on the right connector. The microphone input range is -4dB to +41dB. This option is only available on models with front panel XLR inputs.

If **Line/Mic+PP** is selected, the unit is set to accept a line input on the left connector, and input from a microphone on the right connector. Phantom power is output on pins 2 and 3 of the right connector to power the microphone. The microphone input range is -4dB to +41dB. This option is only available on models with front panel XLR inputs.

5.8.2 VIDEO



Under the **Video** sub-menu, the user can select any one of ten video settings, plus adjust the GOP setting.

The video input type selections are:

- **0: NTSC: 720x480(4:2:0)11**
The following require >10mbps
- **1: NTSC: 720x525(4:2:2)**
The following require >19mbps
- **2: 1080/59.94i:MP@HL**
- **3: 1080/59.94i:MP@H14L**
- **4: 720/59.94p:MP@HL**
- **5: PAL:720x576(4:2:0)11**
- **6: PAL:720x625(4:2:2)**
- **7: 1080/50i:MP@HL**
- **8: 1080/50i:MP@H14L**
- **9: 720/50p: MP@HL**

Using the **GOP** setting, the user can specify the type and amount of frames and the sequence used. The available selections for this setting are:

- 0: Super Low Delay** – very fast encoding with low latency (the time it takes a data packet to move across a network connection).
- 1: IP–15 Frame** – encoding utilizing Intra and Prediction frames, with a sequence of 15 frames.
- 2: IP–30 Frame** – encoding utilizing Intra and Prediction frames, with a sequence of 30 frames.
- 3: IPB–15 Frame** – (*default*) encoding utilizing Intra, Prediction, and Bi-directional frames, with a sequence of 15 frames.
- 4: IPB–30 Frame** – encoding utilizing Intra, Prediction, and Bi-directional frames, with a sequence of 30 frames.

5: IPBB–16 Frame – the slowest encoding utilizing Intra, Prediction, and Bi-directional frames, with a sequence of 16 frames, but with double bi-directional frames. It has the highest type of encoding quality.

5.8.3 SERVICE



The **Service** sub-menu addresses how MPEG-2 data packets are identified during transmission. The following values can be set by the user:

- **Service Name:** (16 characters)
- **Service Provider:** (16 characters)
- **PCR PID:** (hexadecimal value)
- **Video PID:** (hexadecimal value)
- **Audio 1 PID:** (hexadecimal value)
- **Audio 2 PID:** (hexadecimal value)

(Refer to Section 5.1.1: **Changing Characters.**)

5.9 System Menu Selections



The System Menu establishes the general operating parameters for the ChannelMaster TX7. The System Menu has seven sub-menus:

- **Options**
- **Remote**
- **Version**
- **Restore**
- **Frequency**
- **Factory**
- **BAS**

5.9.1 OPTIONS



With the **Option** sub-menu, the user can set the various miscellaneous parameters utilized by the system. The parameters for this sub-menu are:

- **Frequency Direct:** (*Yes*, *No*) - If “Yes”, the user can change the frequency from the default screen, via the Quick Knob. If “No”, the frequency can only be changed via the frequency menu.
- **Start in:** Controls the startup mode of the unit.
 - **NORM** - RF Transmitter on
 - **STBY** – Standby
 - **VIDSTB** - Video Standby
 - **LAST** - Starts in same mode as when previously shutdown.
- **Save Preset** - allows the user to enable (*Yes*) or disable (*No*) the saving of Presets.
- **BAS Menu:** (*Yes*, *No*) - The system will display (*Yes*) or hide (*No*) the BAS options menu.
- **Preset Lock RF CH:** (*Yes*, *No*) - If “Yes”, the channel may not be changed by a preset.
- **Video Present:** (*Stdby*, *Bars*) - should the video signal be lost, this parameter allows the user to choose between the TX7 going into Standby Mode or displaying Color Bars.

5.9.2 REMOTE



With the **Remote** sub-menu, the user can set the various parameters utilized

by the system for distance remote control communications. The parameters for this sub-menu are:

- **Mode:** (*Remote/Local*, *Local*) - allows the unit to be toggled between *Remote* & *Local* control, and *Local (only)* control.
- **Interface:** (*RS232*, *RS485*) - selects between the two types of serial interface communication.
- **Address:** (*hexadecimal value*) - sets the remote address of the ChannelMaster TX7.
- **Baud Rate:** (*2400*, *9600*, *19200*, *38400*, *57600*, *115200*) - sets the speed of the serial connection.

5.9.3 VERSION



With the **Version** sub-menu, the user can view general system information:

- **Serial Number**
- **Model Number**
- **Front Panel Revision**
- **Configuration Data**
- **Frequency Plan Number**

5.9.4 RESTORE



The **Restore** option allows the user to restore all factory defaults to the TX7.

Caution, all previously stored changes will be erased from memory, including Presets.

5.9.5 FREQUENCY



The **Frequency** option allows an experienced user to modify the frequency plan utilized by the ChannelMaster TX7 using the front panel LCD. **Extreme caution should be used, since changes will affect the RF function of the unit.**

5.9.6 FACTORY



The **Factory Settings are to be used by Nucomm authorized personnel only!** Any unauthorized tampering could make the unit unstable or unusable.

5.9.7 BAS



For the **BAS** (formerly “NEXTEL”) sub-menu, see Section 5.7: **BAS Relocation Settings**.

5.10 Monitoring Menu Selections

5.10.1 MONITOR



The **Monitor** option allows the user to monitor operational conditions of several components while the unit is in use.

These include:

- **PSU**
- **Temperature**
- **Modulator**
- **Upconverter**
- **Front Panel**

NOTE: For PSU values, all voltages are set to alarm at a condition of $\pm 10\%$.

Alarms are reported when errors occur during the operation of the ChannelMaster TX7. The alarm may be the result of a detected broken communications link or an improper input (*etc.*), and not the fault of the unit itself. Regardless of the problem, the Alarm LED will illuminate, and the LCD will flash a text message stating the alarm problem.

5.10.2 ALARM



Working in conjunction with the **Alarms** function, the **Alarm** History List allows the user to view any active alarm(s) currently affecting the system. When the alarm problem is resolved, the alarm will disappear from the listing.

5.11 BAS Relocation Settings

For our US clients, the *ChannelMaster* is designed so that, when properly configured per the following guidelines, **you will only need to change one setting on one screen** when it's time to switch over to the "post-relocation" 2 GHz band plan.

To preset the unit to allow a "one setting" switchover, there are two groups of settings that must be made in advance: "AUDIO SUB-CARRIER FREQUENCY" and "CHANNEL BANDWIDTH & BAND PLAN". These are described below.

5.11.1 Audio Sub-Carrier Frequency

In this section, you set your "pre-relocation" and "post-relocation" Audio Sub-Carrier (ASC) frequencies, so that when you make the switchover they will be ready to go.

Start the ASC set-up procedure by making the following menu selections:

MENU>MODULATION>PARAMETER SETUP>FM>AUDIO

This brings up a screen similar to the one at right, with the settings and selections as described below. *All ASC's are modified in the same fashion. ASC#1 is used as the example.*

←	SC1 Insertion:	(-20 to -40dBc)
	2(17)/7/13:	4.83 MHz
	2(12) 1-7:	4.83 MHz
	2(12) 8-10:	4.83 MHz

2(17)/7/13 This setting controls the frequency for the selected Sub-Carrier when operating in the "pre-relocation" 2 GHz band (*USA*), as well as for all the other frequency bands (*i.e. 7 GHz or 13 GHz*). The possible range for this setting is 4.83 MHz to 8.5 MHz. (Refer to Section 5.2.1 - **Changing Operating Frequency**.)

2(12) 1-7 This setting controls the frequency for the selected Sub-Carrier when operating in the "post-relocation" 2 GHz band (*USA*) on channels 1 through 7. The possible range for this setting is 4.83 MHz to 5.8 MHz. (Refer to Section 5.2.1 - **Changing Operating Frequency**.)

2(12) 8-10 This setting controls the frequency for the selected Sub-Carrier when operating in the "post-relocation" 2 GHz band (*USA*) on channels 8 through 10. The possible range for this setting is 4.83 MHz to 8.5 MHz. (Refer to Section 5.2.1 - **Changing Operating Frequency**.)

Nucomm's Default Audio Sub-carrier Frequencies				
<i>Band-plan</i>	<i>ASC1</i>	<i>ASC2</i>	<i>ASC3*</i>	<i>ASC4*</i>
2(17)/7/13	4.83 MHz	6.20 MHz	6.80 MHz	7.50 MHz
2(12) 1-7	4.83 MHz	5.80 MHz	6.80 MHz	7.50 MHz
2(12) 8-10	4.83 MHz	6.20 MHz	6.80 MHz	7.50 MHz

***NOTE:** Due to bandwidth limitations, only two ASC's can be active on the "post-relocation" 2 GHz band-plan (US), regardless of how the unit is hardware configured.

5.11.2 Channel Bandwidth and Band Plan

In this section, you can set your “pre-relocation” and “post-relocation” Video Bandwidth Deviation, so that when you make the switchover they will be ready to go.

Start by making the following menu selections: **MENU>SYSTEM>BAS**.
(Note: If the BAS screen is not visible then it must be enabled by selecting **MENU>SYSTEM>OPTIONS>BAS MENU=YES**.)

This brings up the screen at right, with the settings and selections as described below:

2GHz Freq Plan: 2G(17), 2G(12) BW(2G(17)/7/13): 4MHz, 3MHz BW(2G(12)8-10): 4MHz, 3MHz
--

2GHz Freq Plan

This setting controls the 2 GHz Frequency Plan, which will be used by the radio. Select the 17 MHz “pre-relocation” band-plan by choosing “2G(17)”, or the 12 MHz “post-relocation” band-plan by choosing “2G(12)”.

BW(2G(17)(7/13)

This setting controls your Video Deviation bandwidth when operating in the “pre-relocation” 2 GHz band (USA), as well as for all the other frequency bands (*i.e.* 7 GHz or 13 GHz). The possible selections are 3 MHz or 4 MHz.

BW(2G(12) 8-10)

This setting controls the Video Deviation bandwidth when operating in the “post-relocation” 2 GHz band (USA) on channels 8 through 10. The possible selections are 3 MHz or 4 MHz.

NOTE: *Due to bandwidth limitations of the “post-relocation” 2 GHz band-plan, in “2G(12)” mode, the Video Deviation bandwidth of 2 GHz channels 1 through 7 is locked at 3 MHz.*

5.11.3 Switchover to “Post-relocation” Settings

For our US clients, when your DMA switchover date arrives, assuming you have already set the unit per the preceding guidelines, you will only need to take the following steps to put the radio on the new “post-relocation” settings:

Step #1: **Navigate** to the following menu: **MENU>SYSTEM>BAS**

Step #2: **Change** your “2 GHz Freq Plan” setting from “2G(17)” to “2G(12)”

Step #3: **Done!**

Underlining denotes a Factory Default setting.

Certain menu items may not be available on a given system due to the many customizable features.



¹Only available with Digital Modulation

²Only available with SDI input

³TX7T only

⁴Factory defaults: 4.83, 6.2, 6.8, 7.5MHz

⁵Only available with Analog Modulation

⁶Bit rate forced to 384k in GOP 0 mode.

⁷Disabled in HD mode.

⁸The video bit rate will be limited to 15mpbs.

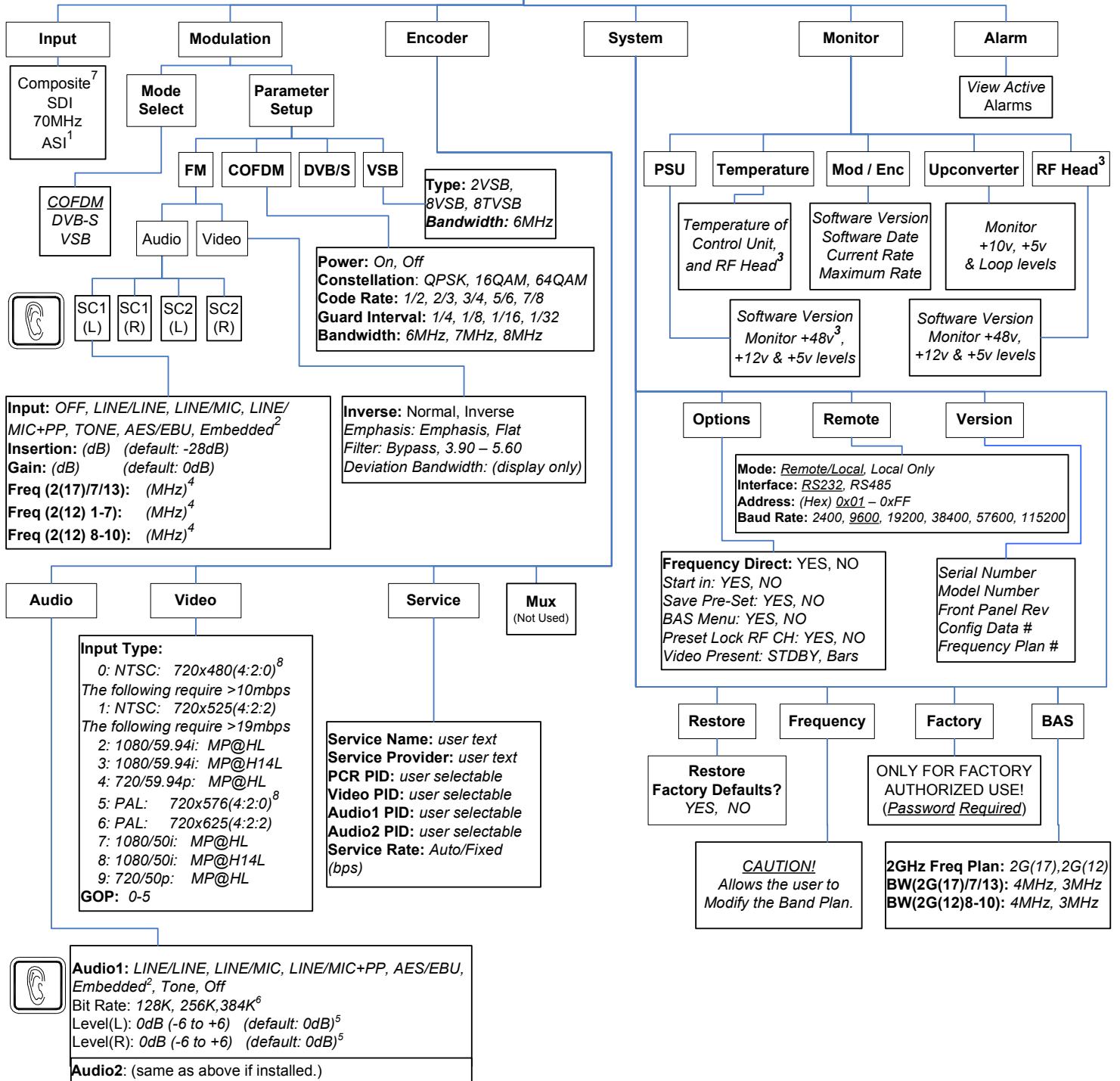



RF Extreme, LLC – A Vitec Group Company
101 Bilby Road
Hackettstown, NJ 07840
Tel: 908-852-3700 Fax: 908-813-0399
www.RFExtreme.com