

10	熱縮套管(透明)	∅2.5 * L:20.0mm	2	碁崴			
9	導電鍍布(ET-CH)	L:80.0 W:5.0	3	鉛寶			
8	SPONGE	11.0*3.0*4.0t	2	Sheng Feng			
7	3M468薄膜雙面膠	3M468 64.0*5.6mm	2	Sheng Feng			
6	Antenna (PIFA)	HV-070-CLE	2	Sheng Feng			
5	熱縮套管(GREEN)	∅1.5 t:0.4 L:30.0mm	1	碁崴			
4	熱縮套管(BLACK)	∅1.5 t:0.4 L:30.0mm	1	碁崴			
3	熱縮套管(BLACK)	∅2.5 t:0.25 L:90.0mm	1	漢保			
2	Connector	20278-111R-13	2	I-PEX			
1	Coaxial Cable	0.7DS-PBE(1.13 GRAY)	2	Sumitomo			
ITEM	DESCRIPTION	VENDOR P/N	Q'TY	REMARK	REV.	DATE	DESCRIPTION

RANGE	TOLERANCE	Antenna Dimensions for CLEVO 5600 Antenna-R&L Ass'y	
OVER 300	±3.0	P/N:23-742R4-A20	DRN NO.: 23-742R4-A20
101-300	±2.5	APPD: Frentzen_Hsu	DRN: Charles_Teng
51-100	±2.0	UNIT: M/M	SHEET: 3 OF 3
31-50	±1.5	碁崴 電子股份有限公司 HIGH-TEK HARNESS GROUP	
BELOW 30	±1.0		

鉛寶科技有限公司

台北市信義路3段109-7號11F-2

Tel: (02)2702-2060

Fax: (02)2702-2070

1. E-FLEX 導電性布膠帶之特性表:

項 目		特 性
抗 張 強 度	kg/25mm	15.0 以上
厚 度 方 向 阻 抗	ohm /sqin	0.2 以下
黏 著 力		
儀 器	器：日本 AIKOH 拉力距	
條 件	件：25mm 寬之背膠導電布,在溫度-5°C~50°C 下 施加 2 公斤之力量黏著後,每分鐘 300 mm 的回拉力下實驗,拉回 5mm 可承受之力量。	

時間/公克 材 質	初 期	1 小 時	24 小 時	48 小 時
不 銹 鋼	120 公克	400 公克	800 公克	1 公斤
PC+ 織	150 公克	200 公克	400 公克	600 公克
PVC	150 公克	300 公克	600 公克	800 公克
PET/Cu/Ni	120 公克	200 公克	400 公克	500 公克

2. 低溫狀況下之使用條件

膠帶於自然環境低溫狀態下必須使用時,需將膠帶回溫至室溫
(約 20°C) 3 小時以上再行使用。

3. 包裝

膠帶製品以包裝紙或收縮膜包裝完成,並裝於適當之紙箱內。

4. 膠帶之保管及品質保證期間

膠帶應放置於陰涼處所,避免高溫高濕或日曬,以妥為保管條件下,
品質保證期間為製造後 6 個月。

PART NO.
20278-**1R-**

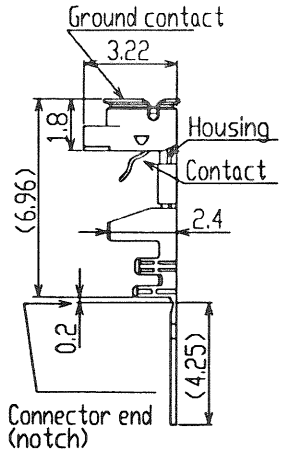
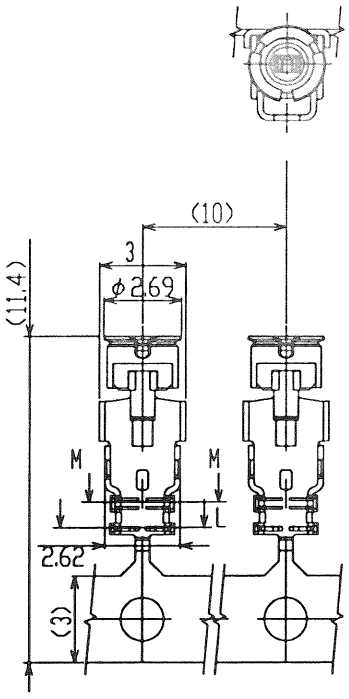

Part No.20278-101R-**
For hand tool
(with notch)

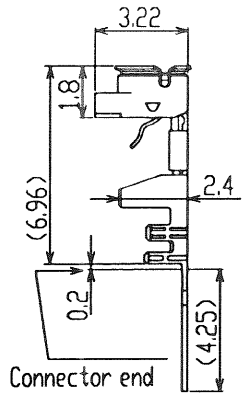

Part No.20278-111R-**
For semi auto
termination machine
(without notch)

GENERAL TOLERANCE	
6 MAX.	±0.2
6 OVER MAX.30	±0.3
30 OVER MAX.120	±0.5
ANGLE	±2°

			4	2023	K.O	JAN/30/02	E.K	DESIGN'D BY	DATE	I-PEX Interconnect and Packaging Electronics TOKYO, JAPAN				
			3	21256	K.O	NOV/14/01	K.K	K.Ohbayashi	JUN/13/01					
			2	21197	K.O	AUG/27/01	K.K	CHK'D BY	DATE					
			1	21118	K.O	JUN/26/01	K.K	APP'D BY	DATE					
7B	Z2180	K.O	JUL/29/02	E.K	0	21109	K.O	JUN/13/01	APP'D BY	DATE	TITLE	MHF series micro coaxial connector plug vertical		
6B	Z2146	K.O	JUN/24/02	K.K	REV	ECN	BY	DATE	APP	K.Katabuchi	JUN/13/01			
5B	Z2117	A.H	MAY/17/02	K.K	REV	RECORD								
REV	ECN	BY	DATE	APP	SERIES No.	2814		CUSTOMER COPY	PROJECTION	SCALE	UNIT	DWG. No.	SHEET	REV.
									6/1mm			20278	1/3	7B

FORM REV.4

WAS T

Part No.	20278-101R-08 20278-111R-08	20278-101R-13 20278-111R-13	20278-101R-32 20278-111R-32	20278-101R-18 20278-111R-18	
Applicable cable nominal dimension	2.09±0.1 1.25±0.1 1.16±0.1 φ0.81 (φ0.65) φ0.4 AVC#367/005	1.55±0.1 0.82±0.1 1.7±0.1 φ1.13 (φ0.93) φ0.68 AVC#327/008	2.09±0.1 1.25±0.1 1.16±0.1 φ1.32 (φ1.12) φ0.66 AVC#327/008	RG178 B/U 2.09±0.1 1.25±0.1 1.16±0.1 φ1.8 (φ1.35) φ0.84 AVC#307/0102	
Jacket Outer conductor silver or tin plating Dielectric core Inner conductor silver plating					
Braided shield of Outer conductor 外部導体の編組	Single / 1重編組	Single / 1重編組	Double / 2重編組	Single / 1重編組	
P/N of hand Tool	<Under developing>	90187-013	<Under developing>	<Under developing>	
P/N of semi auto termination machine		90213-013			
Sect. M-M	1.68 1.12	2.24 1.48	2.29 1.56	2.68 1.85	
Sect. L-L	1.72 1.19	2.28 1.55	2.37 1.71	3.1 2.26	
Crimp Height	CH-1	Under developing	1.34~1.40	Under developing	Under developing
	CH-2	Under developing	1.06~1.14	Under developing	Under developing
	CH-3	Under developing	1.15~1.35	Under developing	Under developing

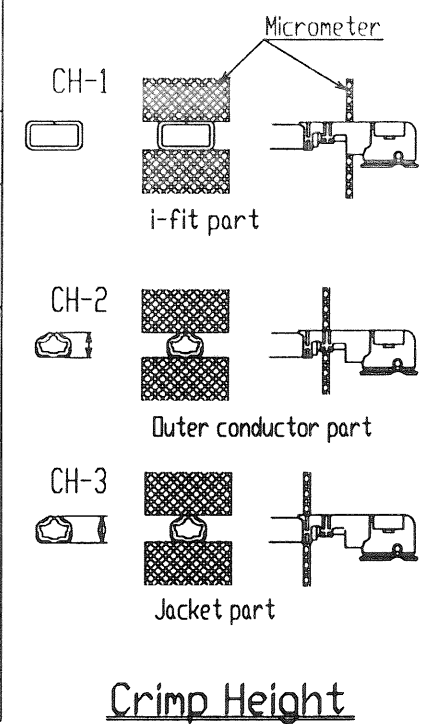

GENERAL TOLERANCE	
6 MAX.	±0.2
6 OVER MAX.30	±0.3
30 OVER MAX.120	±0.5
ANGLE	±2°

DESIGN'D BY	DATE	I-PEX Interconnect and Packaging Electronics TOKYO, JAPAN	TITLE MHF series micro coaxial connector plug vertical	
CHK'D BY	DATE			
APP'D BY	DATE			
CUSTOMER COPY	PROJECTION	SCALE UNIT 6/1MM	DWG. No. 20278	SHEET REV. 2/3 7B

Notes

1. Material

- (1) Housing : PBT, UL94V-0, black
- (2) Contact
phosphor bronze
gold plating
- (3) Ground contact
phosphor bronze, gold plating

2. Packing : reel

3. Mating partner part No.
: 20279-001E-01

1. 材料

- (1) ハウジング : PBT, UL94V-0, 黒色
- (2) コンタクト
: りん青銅
: 金メッキ
- (3) グランドコンタクト
: りん青銅, 金メッキ

2. 梱包 : リール

3. かん合相手 part No.
: 20279-001E-01

4. Permissible load of cable at mating

コネクタかん合後のケーブルに対する荷重

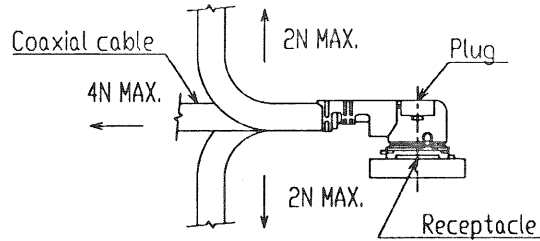

5. Suggestions for mating & unmating operation.

5. コネクタかん合時および抜去時の注意

5-1 Mating.

Please mate the connector straightly to vertical direction as much as possible, adjusting the mating axis of plug and receptacle. As excessive slant angle mating may break the connector, please don't do it.

5-1 コネクタ挿入時

PlugとReceptacleのかん合軸を合わせ、できるだけ垂直に挿入して下さい。極端な斜め挿入は行わないで下さい。コネクタ破損の原因となりますので、過度なこじり挿入は行わないで下さい。

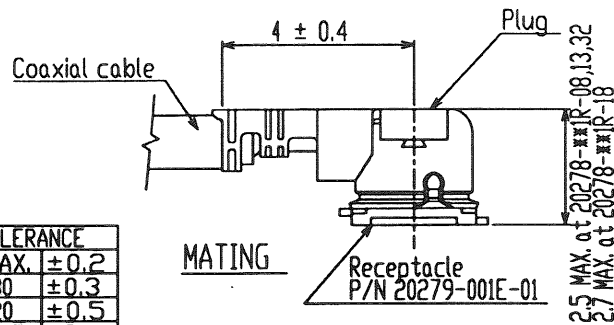

GENERAL TOLERANCE	
6 MAX.	±0.2
6 OVER MAX.30	±0.3
30 OVER MAX.120	±0.5
ANGLE	±2°

FORM REV.4

5-2 Unmating.

5-2 コネクタ抜去時

(1) In case of unmating by pulling tool.
Please use the pulling tool as the following drawing, and please pull plug to vertical direction as directly as possible.

(1) 抜きジグを用いる場合
下図のようにできるだけ垂直に引き抜いて下さい。

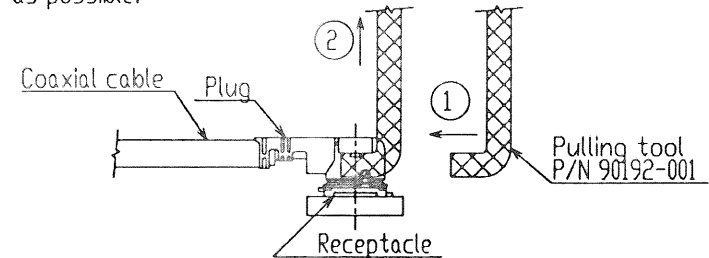

(2) In case of unmating directly by hand
Please catch the catching area of plug, and please pull plug to vertical direction as directly as possible.

(2) 手で直接引き抜く場合
下図の保持部をつかみ、できるだけ垂直に引き抜いて下さい。

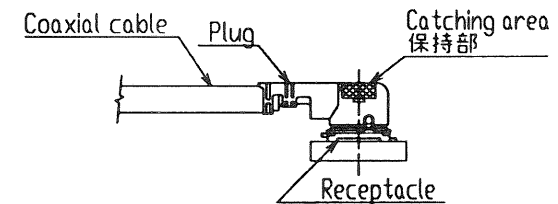

DESIGN'D BY	DATE	 Interconnect and Packaging Electronics TOKYO, JAPAN	TITLE	MHF series micro coaxial connector plug vertical	SHEET REV.		
CHK'D BY	DATE					DWG. No.	3/3
APP'D BY	DATE						
CUSTOMER COPY	PROJECTION	SCALE UNIT	20278				

WAS T

PRODUCT SPECIFICATION

製品規格

No. PRS-1176

MHF series micro coaxial connector

Qualification Test Report No. TR-1021

					Prepared by	Reviewed by	Approved by
1	S1053	K.O	Nov/14/'01	K.K	K.Ohbayashi	E,Kawabe	K.Katabuchi
0	S1025	K.O	Jun/25/'01				
REV.	ECN	BY	DATE	APP.	JUN / 25 / 01	Jun / 25 / 01	Jun / 29 / 01
REVISION RECORD							

DOCUMENT CLASSIFICATION	TITLE	No.
Product Specification 製品規格	MHF series micro coaxial connector	PRS-1176
<p>1. Scope / 序言 MHF series micro coaxial connector is a wire to board connector for AWG#36,32,30 coaxial cable . MHF series micro coaxial connector は、AWG # 36,32,30同軸ケーブルの基板対ワイヤーコネクタである。</p> <p>2. Objectives / 目的 This specification covers the requirements for product performance and test methods of MHF series microcoaxial connector 本規格は、MHF series micro coaxial connector の性能と試験条件について規定する。</p> <p>3. Part No. , construction , material and finish / 構成、材料及び仕上げ (1) Part No. Plug : 20278-001R-08,-13,-18 , Receptacle : 20279-001E-01 (2) Construction, material and finish of the connector are covered as each drawings. 構成、材料及び仕上げは、各図面に指定されている通りとする。</p> <p>4. Applicable cable / 適合ケーブル 4-1 Part No. 20278-001R-08 (1) Description Inner conductor : AWG#36(7/0.05) Silver plating annealed copper wire or silver plating tin-copper alloy Dielectric core : Fluoro-plastics ,diameter 0.4(+0.04,-0.02)mm , nominal thickness 0.125mm Outer conductor : 8/5/0.05 , nominal diameter 0.65mm , silver plating annealed copper wire Jacket : Fluoro-plastics , diameter 0.81(+0.04,-0.02)mm , nominal thickness 0.08mm (2) Requirements Characteristic impedance : 50(+3,-3)ohm by TDR method (raise time 40ps) Nominal capacitance: 96 pF/m Conductor resistance of inner conductor at 293K (20°C) : 1400 ohm/km MAX. Insulation resistance : 1000 mega-ohm.km MIN. Dielectric withstand voltage : no breakdown at AC1000V for 1 minutes.</p> <p>(1) 構成 中心導体 : AWG # 36 (7 / 0.05) , 銀メッキ軟銅線または銀メッキすず入り銅線 誘電体 : フッ素樹脂, 外径0.4 (+0.04, -0.02) , 標準厚さ0.125mm 外部導体 : 8 / 5 / 0.05 , 標準外径0.65mm , 銀メッキ軟銅線 ジャケット : フッ素樹脂, 外径0.81 (+0.04, -0.02)mm , 標準厚さ0.08mm</p> <p>(2) 仕様 特性インピーダンス : 50 ± 3 Ω (TDR, ライズタイム40ps) 標準静電容量 : 96pF / m 293K (20°C) 時の中心導体導体抵抗 : 1400 Ω / km以下 絶縁抵抗 : 1000MΩ · km以上 耐電圧 : AC1000V · 1分間にて絶縁破壊の無い事</p> <p>4-2 Part No. 20278-001R-13 (1) Description Inner conductor : AWG#32(7/0.08) Silver plating annealed copper wire or silver plating tin-copper alloy Dielectric core : Fluoro-plastics , diameter 0.68(+0.04,-0.02)mm , nominal thickness 0.22mm Outer conductor : 16/4/0.05 , nominal diameter 0.93mm , silver plating annealed copper wire Jacket : Fluoro-plastics , diameter 1.13(+0.08,-0.05)mm , nominal thickness 0.1mm</p>		

DOCUMENT CLASSIFICATION Product Specification 製品規格	TITLE MHF series micro coaxial connector	No. PRS-1176
--	--	-----------------

(2) Requirements

Characteristic impedance : 50(+2,-2)ohm by TDR method (raise time 40ps)
Nominal capacitance: 97 pF/m
Conductor resistance of inner conductor at 293K (20°C) : 520 ohm/km MAX.
Insulation resistance : 1500 mega-ohm.km MIN.
Dielectric withstand voltage : no breakdown at AC1000V for 1 minutes.

(1) 構成

中心導体 : AWG # 32(7/0.08),銀メッキ軟銅線または銀メッキすず入り銅線
誘電体 : フッ素樹脂,外径0.68(+0.04,-0.02),標準厚さ0.22mm
外部導体 : 16/4/0.05,標準外径0.93mm, 銀メッキ軟銅線
ジャケット : フッ素樹脂,外径1.13(+0.08,-0.05)mm, 標準厚さ0.1mm

(2) 仕様

特性インピーダンス : 50±2Ω (TDR,ライズタイム40ps)
標準静電容量 : 97pF/m
293K(20°C)時の中心導体導体抵抗 : 520Ω /km以下
絶縁抵抗 : 1500MΩ・km以上
耐電圧 : AC1000V・1分間にて絶縁破壊の無い事

4-3 Part No. 20278-001R-32

(1) Description

Inner conductor : AWG#32(7/0.08)

Silver plating annealed copper wire or silver plating tin-copper alloy

Dielectric core : Fluoro-plastics , diameter 0.66(+0.05,-0.05)mm , nominal thickness 0.21mm

First outer conductor : 16/5/0.05, tin plating annealed copper wire

Second outer conductor :16/6/0.05, nominal diameter 1.12mm , tin plating annealed copper wire

Jacket : Fluoro-plastics , diameter 1.32(+0.1,-0.1)mm , nominal thickness 0.1mm

(2) Requirements

Characteristic impedance : 50(+2,-2)ohm by TDR method (raise time 40ps)
Nominal capacitance: 95 pF/m
Conductor resistance of inner conductor at 293K (20°C) : 520 ohm/km MAX.
Insulation resistance : 1500 mega-ohm.km MIN.
Dielectric withstand voltage : no breakdown at AC1000V for 1 minutes.

(1) 構成

中心導体 : AWG # 32(7/0.08),銀メッキ軟銅線または銀メッキすず入り銅線
誘電体 : フッ素樹脂,外径0.66(+0.05,-0.05),標準厚さ0.21mm
外部導体(内側) : 16/5/0.05,すずメッキ軟銅線
外部導体(外側) : 16/6/0.05,標準外径1.12mm, すずメッキ軟銅線
ジャケット : フッ素樹脂,外径1.32(+0.1,-0.1)mm, 標準厚さ0.1mm

(2) 仕様

特性インピーダンス : 50±2Ω (TDR,ライズタイム40ps)
標準静電容量 : 95pF/m
293K(20°C)時の中心導体導体抵抗 : 520Ω /km以下
絶縁抵抗 : 1500MΩ・km以上
耐電圧 : AC1000V・1分間にて絶縁破壊の無い事

DOCUMENT CLASSIFICATION Product Specification 製品規格	TITLE MHF series micro coaxial connector	No. PRS-1176
<p>4-4 Part No. 20278-001R-18 RG178 B/U</p> <p>(1) Description Inner conductor : AWG#30(7/0.102) , silver plating copper clad steel wire Dielectric core : Fluoro-plastics , diameter 0.84(+0.03,-0.03)mm , nominal thickness 0.268mm Outer conductor : 16/3/0.1 , nominal diameter 1.35mm , silver plating copper wire Jacket : Fluoro-plastics , diameter 1.8(+0.1,-0.1)mm , nominal thickness 0.23mm</p> <p>(2) Requirements Characteristic impedance : 50(+2,-2)ohm by TDR method (raise time 40ps) Nominal capacitance: 95 pF/m Conductor resistance of inner conductor at 293K (20°C) : 805 ohm/km MAX. Insulation resistance : 1500 mega-ohm.km MIN. Dielectric withstand voltage : no breakdown at AC2000V for 1 minutes.</p> <p>(1) 構成 中心導体 : AWG # 30(7/0.102), 銀メッキ銅被鋼線 誘電体 : フッ素樹脂, 外径0.84(±0.03), 標準厚さ0.268mm 外部導体 : 16/3/0.1, 標準外径1.35mm, 銀メッキ軟銅線 ジャケット : フッ素樹脂, 外径1.8(±0.1)mm, 標準厚さ0.23mm</p> <p>(2) 仕様 特性インピーダンス : 50±2Ω (TDR, ライズタイム40ps) 標準静電容量 : 95pF/m 293K(20°C)時の中心導体導体抵抗 : 805Ω /km以下 絶縁抵抗 : 1500MΩ・km以上 耐電圧 : AC2000V・1分間にて絶縁破壊の無い事</p> <p>5. Ratings / 定格 (1) Rated voltage / 電圧 : AC60Vrms (2) Nominal characteristic impedance / 公称特性インピーダンス : 50Ω (3) Frequency / 周波数 : DC~3GHz (4) VSWR : 1.3 MAX. (5) Service Temperature / 使用温度範囲 : 233~363K(-40~+90°C)</p> <p>6. Test methods and performance / 試験及び性能</p> <p>6-1 Test condition / 試験条件 Unless otherwise specified, all tests and measurements shall be performed under the following conditions in accordance with MIL-STD-202 全ての測定と試験は、MIL-STD-202に基づき以下の条件で行う。 Temperature / 温度 : 288~308K (15~35°C) Humidity / 湿度 : 45~75%RH</p>		

DOCUMENT CLASSIFICATION Product Specification 製品規格	TITLE MHF series micro coaxial connector	No. PRS-1176
--	--	-----------------

6-2 Sample quantity / 試料数

- (1) Insulation resistance / 絶縁抵抗 : 10pcs.
- (2) Dielectric withstanding voltage / 耐電圧 : 10pcs.
- (3) VSWR : 5pcs.
- (4) Mating & unmating force / 挿抜力 : 10pcs
- (5) Durability / 耐久性 : 10pcs.
- (6) Cable retention force / ケーブル保持力 : 10pcs.
- (7) Vibration / 振動 : 10pcs.
- (8) Shock / 衝撃 : 10pcs.
- (9) Thermal shock / 温度サイクル : 10pcs.
- (10) Humidity / 湿度 : 10pcs.
- (11) Salt water spray / 塩水噴霧 : 10pcs.
- (12) Solderability / 半田付け性 : 10pcs.
- (13) Reflow soldering heat resistance / 半田耐熱性 : 10pcs.

6-3-1 Electrical / 電氣的性能

(1) Contact Resistance / 接触抵抗

A. Testing: Solder the receptacle connector to the test board and mate the plug connector together, then measure the contact resistance as shown in Fig.1 by the four terminal method.

Apply the low level condition in accordance with MIL-STD-202, Method 307.

Open circuit voltage : 20mV MAX

Circuit current : 10mA MAX. (DC or AC1kHz)

Contact resistance of inner contact : <resistance of A-E> - <resistance of B-E>

Contact resistance of ground contact : <resistance of A-D> - <resistance of B-D>

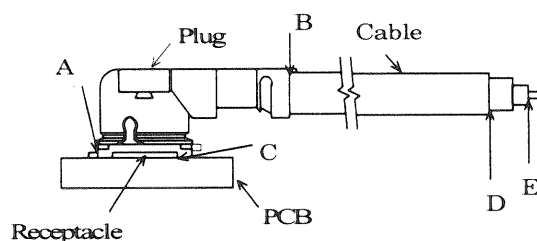

Fig.1

B. Requirements :

Contact resistance of inner contact initial 20 milli-ohm MAX. after testing 25milli-ohm MAX.

Contact resistance of ground contact initial 10 milli-ohm MAX. after testing 15milli-ohm MAX.

A. 試験法: テスト基板にリセプタクルコネクタを半田付けし、プラグコネクタと嵌合させ、Fig. 1のように4端子法にて下記の条件で測定する。MIL-STD-202 試験法 307 に準拠。

開回路電圧: 20mV以下

試験電流 : 10mA (DCもしくはAC1kHz)

中心導体 : <A-E間の電気抵抗> - <B-E間の電気抵抗>

外部導体 : <A-D間の電気抵抗> - <B-D間の電気抵抗>

B. 必要条件: 中心導体 初期 20mΩ 以下, 試験後 25mΩ 以下

外部導体 初期 10mΩ 以下, 試験後 15mΩ 以下

DOCUMENT CLASSIFICATION Product Specification 製品規格	TITLE MHF series micro coaxial connector	No. PRS-1176
--	--	-----------------

(2) Insulation resistance / 絶縁抵抗

A. Testing : Mate the plug and receptacle connector together, then apply DC 100 V between the inner contact and the ground contact in accordance with MIL-STD-202, Method 302.

B.Requirements : Initial 500 Mohm MIN. after testing 100 Mohm MIN.

A.試験法: リセプタクル及びプラグコネクタを互いに嵌合させ、中心導体と外部導体の間に DC 100Vを印加し、測定する。MIL-STD-202 試験法 302 に準拠。

B.必要条件: 初期 500MΩ 以上 試験後 100MΩ 以上

(3) Dielectric withstanding voltage / 耐電圧

A. Testing : Mate the receptacle and plug connector together, then apply AC 200 Vrms between the inner contact and the ground contact for a minute in accordance with MIL-STD-202, Method 301.

B.Requirements : No creeping discharge, flashover, nor insulator breakdown shall occur.

A.試験法: リセプタクル及びプラグコネクタを互いに嵌合させ、中心導体と外部導体の間にAC200V(実効値)を一分間印加する。MIL-STD-202 試験法 301 に準拠。

B.必要条件: 沿面放電、空中放電、絶縁破壊等の異常のないこと。

(4) VSWR

A. Testing : Measure the VSWR as shown in Fig.3 by the network analyzer.

Frequency : 100M~3GHz

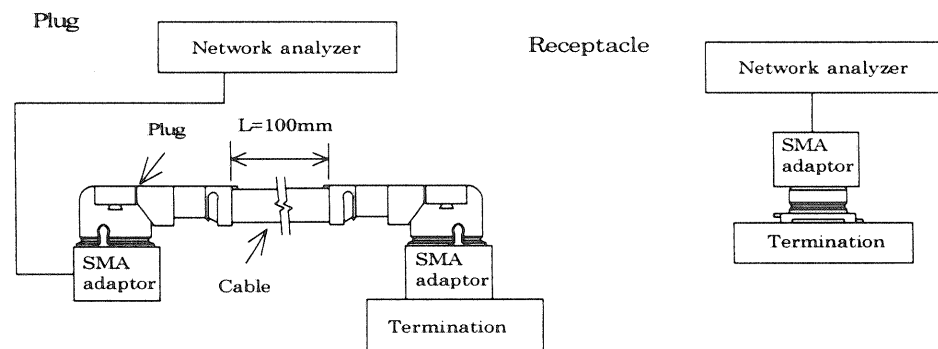

Fig.3

B.Requirements : 1.3 MAX.

A.試験法: ネットワークアナライザにて Fig.3 のようにVSWRを測定する。

周波数 : 100M~3GHz

B.必要条件: 1.3以下

6-3-2 Mechanical / 機械的性能

(1) Mating & unmating force / 挿抜力

A. Testing : Mate and unmate the receptacle connector (soldered to the test board) and plug at a speed 25 ± 3 mm/minutes along the mating by the push-on/pull-off machine .

B.Requirements :

Total mating force : Initial 20N MAX. after 30 cycles 15N MAX.

Total unmating force : Initial 5N MIN. after 30 cycles 3N MIN.

Unmating force of inner contact : Initial 0.15N MIN. after 30 cycles 0.1N MIN

DOCUMENT CLASSIFICATION Product Specification 製品規格	TITLE MHF series micro coaxial connector	No. PRS-1176
--	--	-----------------

A.試験法:挿抜試験機を用いて、基板に半田付けしたリセプタクルとプラグを嵌合軸と平行に毎分 25 ± 3 mmの速度で挿抜する。

B.必要条件:

総合挿抜力:初回挿入力 20N以下 30回後15N以下 ,初回抜去力 5N以上 ,30回後抜去力 3N以上
中心導体 :初回抜去力 0. 15N以上 ,30回後抜去力 0. 1N以上

(2) Durability / 耐久性

A. Testing : Mate and unmate the receptacle connector (soldered to the test board) and plug 30 cycles at a speed 25 ± 3 mm/minutes along the mating by the push-on/pull-off machine .

B.Requirements :

Contact resistance of inner contact initial 20 milli-ohm MAX. after testing 25milli-ohm MAX.

Contact resistance of ground contact initial 10 milli-ohm MAX. after testing 15milli-ohm MAX.

A.試験法:挿抜試験機を用いて、基板に半田付けしたリセプタクルとプラグを嵌合軸と平行に毎分 25 ± 3 mmの速度で30回挿抜する。

B.必要条件 中心導体接触抵抗 : 初期 20mΩ 以下, 試験後 25mΩ 以下

外部導体接触抵抗 : 初期 10mΩ 以下, 試験後 15mΩ 以下

(3) Cable retention force / ケーブル保持力

A. Testing : Apply force on the cable as shown in Fig.2.

During the testing, run 100mA DC to check electrical discontinuity.

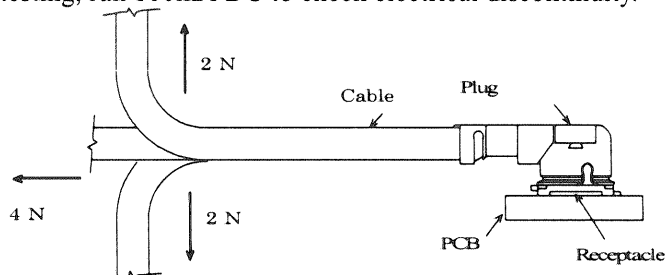

Fig.2

B.Requirements

Appearance : Looseness between the parts, chipping, breakage or other abnormality shall not occur.

Electrical discontinuity : No electrical discontinuity greater than 1 micro-sec. shall occur.

Contact resistance of inner contact initial 20 milli-ohm MAX. after testing 25milli-ohm MAX.

Contact resistance of ground contact initial 10 milli-ohm MAX. after testing 15milli-ohm MAX.

A.試験法:Fig. 2のようにケーブルに力を加える。尚、試験中にDC100mAの電流を流して電氣的瞬断を確認する。

B.必要条件 外観 : 部品のゆるみ、欠け、割れ、その他外観上の異常の無いこと。

電流瞬断 : 試験中、1 マイクロ秒を超える電氣的瞬断の無いこと。

中心導体接触抵抗 : 初期 20mΩ 以下, 試験後 25mΩ 以下

外部導体接触抵抗 : 初期 10mΩ 以下, 試験後 15mΩ 以下

DOCUMENT CLASSIFICATION Product Specification 製品規格	TITLE MHF series micro coaxial connector	No. PRS-1176
--	--	-----------------

(4) Vibration / 振動

A. Testing : Apply the following vibration to the mating connector .

During the testing, run 100mA DC to check electrical discontinuity.

Frequency : 10Hz → 100Hz → 10Hz / approx 15 minutes.

Half amplitude, Peak value of acceleration: 1.5mm or 59m/s² (6G)

Directions , cycle : 3 mutually perpendicular direction ,

5 cycles(approx 75min)about each direction

B.Requirements

Appearance : Looseness between the parts, chipping, breakage or other abnormality shall not occur.

Electrical discontinuity : No electrical discontinuity grater than 1micro-sec. shall occur.

Contact resistance of inner contact initial 20 milli-ohm MAX. after testing 25milli-ohm MAX.

Contact resistance of ground contact initial 10 milli-ohm MAX. after testing 15milli-ohm MAX.

A.試験法: 嵌合状態のコネクタを、下記の振動を加える。尚、試験中にDC100mAの電流を流して電氣的瞬断を確認する。

周波数 : 10Hz→100Hz→10Hz / 約15分間

片振幅,加速度: 1.5mm or 59m/s² (6G)

方向, サイクル: 3つの互いに直角な方向について各5サイクル(約75分)実施

B.必要条件 外観 : 部品のゆるみ、欠け、割れ、その他外観上の異常の無いこと。

電流瞬断 : 試験中、1 マイクロ秒を超える電氣的瞬断の無いこと。

中心導体接触抵抗 : 初期 20mΩ 以下, 試験後 25mΩ 以下

外部導体接触抵抗 : 初期 10mΩ 以下, 試験後 15mΩ 以下

(5) Shock / 衝撃

A. Testing : Apply the following vibration to the mating connector in accordance with MIL-STD-202, Method 213, Condition B. During the testing, run 100mA DC to check electrical discontinuity.

Peak value of acceleration: 735m/s² (75G)

Duration : 11msec

Wave Form : half sinusoidal

Directions , cycle : 6 mutually perpendicular direction , 3 cycles about each direction

B.Requirements

Appearance : Looseness between the parts, chipping, breakage or other abnormality shall not occur.

Electrical discontinuity : No electrical discontinuity grater than 1 micro-sec. shall occur.

Contact resistance of inner contact initial 20 milli-ohm MAX. after testing 25milli-ohm MAX.

Contact resistance of ground contact initial 10 milli-ohm MAX. after testing 15milli-ohm MAX.

A.試験法: 嵌合状態のコネクタを、衝撃試験機に取り付け、下記の衝撃を加える。尚、試験中にDC100mAの電流を流して電氣的瞬断を確認する。MIN-STD-202 試験法 213 試験条件 B に準拠。

最大加速度: 735m/s² (75G)

標準持続時間: 11msec.

波形: 半波正弦波

方向: 直交する6方向、各3回

B.必要条件 外観 : 部品のゆるみ、欠け、割れ、その他外観上の異常の無いこと。

電流瞬断 : 試験中、1 マイクロ秒を超える電氣的瞬断の無いこと。

中心導体接触抵抗 : 初期 20mΩ 以下, 試験後 25mΩ 以下

外部導体接触抵抗 : 初期 10mΩ 以下, 試験後 15mΩ 以下

DOCUMENT CLASSIFICATION	TITLE	No.
Product Specification 製品規格	MHF series micro coaxial connector	PRS-1176
<p>6-3-3 Environmental / 耐環境性</p> <p>(1) Thermal shock/ 温度サイクル</p> <p>A. Testing : Apply the following environment to the mating connector . Temperature ,duration :233K/30minutes→278~308K/5minutes MAX.→363K/30minutes→278~308K/5minutes MAX. (-40°C) (5~35°C) (90°C) (5~35°C) No. of cycles : 5 cycles</p> <p>B.Requirements Appearance : Looseness between the parts, chipping, breakage or other abnormality shall not occur. Contact resistance of inner contact initial 20 milli-ohm MAX. after testing 25milli-ohm MAX. Contact resistance of ground contact initial 10 milli-ohm MAX. after testing 15milli-ohm MAX. Insulation resistance : initial 500 mega-ohm MIN. after testing 100 mega-ohm MIN.</p> <p>A.試験法: 嵌合状態のコネクタを、下記の雰囲気中に放置する。 1サイクルの条件 :233K / 30分→278~308K / 5分以下→363K / 30分→278~308K / 5分以下 (-40°C) (5~35°C) (90°C) (5~35°C) 実施サイクル : 5サイクル</p> <p>B.必要条件 外観 : 部品のゆるみ、欠け、割れ、その他外観上の異常の無いこと。 中心導体接触抵抗 : 初期 20mΩ 以下、試験後 25mΩ 以下 外部導体接触抵抗 : 初期 10mΩ 以下、試験後 15mΩ 以下 絶縁抵抗 : 初期 500MΩ 以上 試験後 100MΩ 以上</p> <p>(2) Humidity / 湿度</p> <p>A. Testing : Apply the following environment to the mating connector in accordance with MIL-STD-202, Method 103, Condition B . Temperature : 313±2 K (40±2°C) Humidity : 90~95%RH Duration : 96 hours</p> <p>B.Requirements Appearance : Looseness between the parts, chipping, breakage or other abnormality shall not occur. Contact resistance of inner contact initial 20 milli-ohm MAX. after testing 25milli-ohm MAX. Contact resistance of ground contact initial 10 milli-ohm MAX. after testing 15milli-ohm MAX. Insulation resistance : initial 500 mega-ohm MIN. after testing 100 mega-ohm MIN.</p> <p>A.試験法: 嵌合状態のコネクタを、下記の雰囲気中に放置する。MIL-STD-202 試験法 103 条件 B に準拠。 温度:313±2K (40±2°C) 湿度:90~95%RH 時間:96時間</p> <p>B.必要条件 外観 : 部品のゆるみ、欠け、割れ、その他外観上の異常の無いこと。 中心導体接触抵抗 : 初期 20mΩ 以下、試験後 25mΩ 以下 外部導体接触抵抗 : 初期 10mΩ 以下、試験後 15mΩ 以下 絶縁抵抗 : 初期 500MΩ 以上 試験後 100MΩ 以上</p> <p>(3) Salt water spray / 塩水噴霧</p> <p>A. Testing : Apply the following environment to the mating connector in accordance with MIL-STD-202, Method 101, Condition B. Temperature : 308±2 K (35±2°C) Salt water density by weight : 5±1% Duration : 48 hours</p> <p>B.Requirements : Appearance no abnormality adversely affecting the performance shall occur.</p>		

DOCUMENT CLASSIFICATION Product Specification 製品規格	TITLE MHF series micro coaxial connector	No. PRS-1176
--	--	-----------------

A. 試験法: 嵌合状態のコネクタを、下記の雰囲気に放置する。

温度 : $308 \pm 2\text{K}$ ($35 \pm 2^\circ\text{C}$)

塩水濃度: $5 \pm 1\%$ (重量比)

時間 : 48時間

B. 必要条件 : 外観 著しい腐食の無い事。

6-3-4 Solder / 半田付け関連

(1) Solderability / 半田付け性

A. Testing : Dip the solder tine of the contact in the solder bath at $518 \pm 5(245 \pm 5^\circ\text{C})$ for 5 ± 0.5 sec.
After immersing the tine in the flux of RMA or R type for 5 to 10 seconds in accordance with MIL-STD-202, Method 208.

B. Requirements : More than 95% of the dipped surface shall be evenly wet.

A. 試験法: コンタクトの半田付け部を $518 \pm 5\text{K}$ ($245 \pm 5^\circ\text{C}$) の半田槽内に 5 ± 0.5 秒浸す。フラックスは、RMA
又は R 型を使用し 5~10 秒間浸すものとする。MIL-STD-202, 試験法 208 に準拠。

B. 必要条件: 浸した面積の 95% 以上に半田がむらなく付着すること。

(2) Reflow soldering heat resistance / 半田耐熱性

A. Testing : Put on the receptacle connector to PCB, apply the heat 2 cycles as shown in Fig. 4

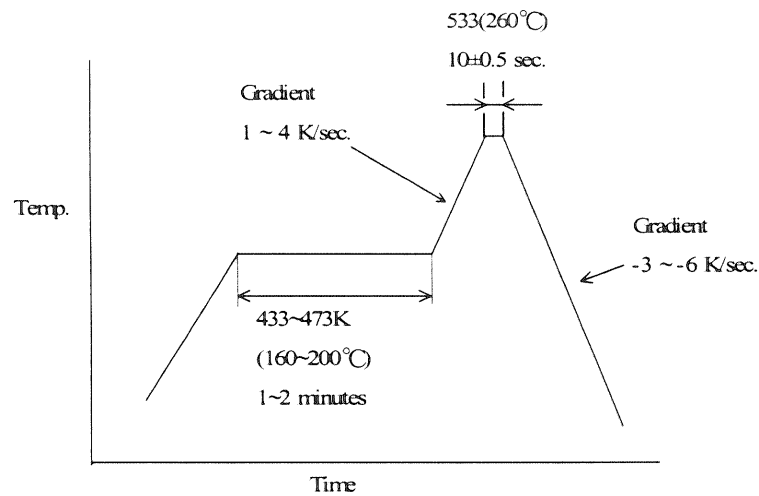

Fig.4

B. Requirements : Appearance no abnormality adversely affecting the performance shall occur.

A. 試験法: 基板にリセプタクルコネクタを置き、Fig. 4の条件で2回リフローを行う。

B. 必要条件: 機能を損なう変形及び欠陥の無い事。