

 SUMITOMO ELECTRIC INDUSTRIES, LTD

Sheet No. 3
IEE8-01026B

4. Packing
Standard unit length of finished cable shall be 500m on reel and shall be packed not to be damaged during transportation.

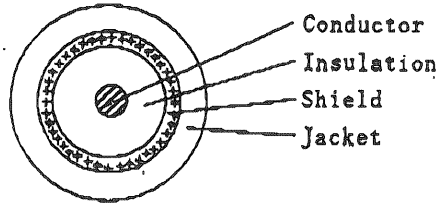

マイクロ

PORON

INC

ROGERS INOAC CORPORATION
TECHNICAL DEPT.

2/8

PORON HH-48C PHYSICAL PROPERTY

PROPERTY	UNIT	DATUM	TEST METHOD
Thickness	mm	± 1.0%	Thickness gauge
Density	g/cm ³	0.48	JIS-K-6401
Tensile strength	kg/cm ²	27.0	JIS-K-6901
Tear strength	kg/cm	7.6	↑
Elongation	%	140	↑
25NCLD	kg/cm ²	4.0	↑
Compression set	%	4.7	JIS-K-6401

(The figure indicates all mean value.)



409x-0

特 性

一般物性

PORONは、各々のタイプにより硬さ、強度等が異なり、各種用途への展開が容易になっています。物性の規格としては、JIS-K-6301に準拠していますが、主な項目は右表のようになっています。

項目	単位	密度	引張強度	引張伸び	引張弾性率	25℃圧縮率
		g/cm ³	kg/cm ²	%	kg/cm ²	%
L-24		0.24	5.5	115	1.8	0.4
L-32		0.32	7.9	150	2.4	0.8
H-32		0.32	14.7	155	3.4	1.4
H-48		0.48	17.4	105	4.1	2.2
U-32		0.32	4.0	115	1.5	0.5
LE-32		0.32	7.6	300	1.4	0.3
RH-48		0.48	27.0	140	7.5	3.0
#4000		0.27	10.2	120	2.5	0.9
CRスポンジ		0.19	5.0	150	2.2	0.6
PEフォーム		0.04	3.2	180	2.1	0.4
試験方法			ダンベル1号	ダンベル1号	ダンベルB型	形状：4 圧縮速度：1m

(値はすべて代表値を示しています)

圧縮残留歪

PORONの最大の特徴である、いつまでもシール性及びクッション性が維持できるということは、右表に示した圧縮残留歪によって理解できます。

条件：JIS-K6401に準じ、50%圧縮時70℃×22時間放置、その後開放30分後の厚み変化を求めた。

項目	PORON					CRスポンジ	Pフォーム
	L-24	L-32	H-32	H-48	U-32		
圧縮残留歪(%)	2.7	3.4	3.1	3.9	4.6	35	45

(値はすべて代表値を示しています)

圧縮残留歪の温度依存性について

PORONは他素材に比べて、温度変化に対して、圧縮残留歪の変化が少ない。

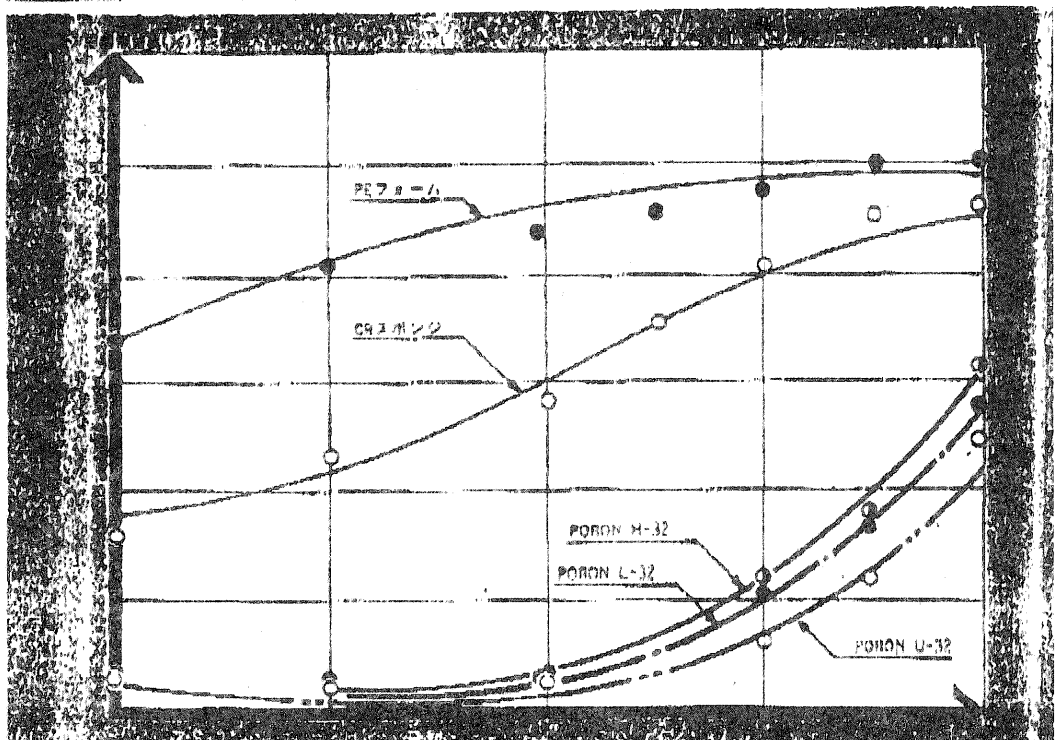

TECHNICAL REPORT

Industrial Adhesive Tape T4000

Industrial Adhesive Tape T4000

Double-Faced Adhesive Tape

T4000 is a double-faced adhesive tape developed for the requirement of strong and permanent bonding. It is a highly selected double-faced adhesive tape with outstanding reliability, having high low-temperature adhesion.

SPECIFICATIONS

Coating amounts (g/m ²)	140-170
Coating thickness (mm)	approx. 0.15
Thickness of release paper (mm)	approx. 0.14

FEATURES

- Excellent in thermal holding strength
- Excellent in low-temperature adhesion
- High bonding strength in the widest temperature range
- No smell
- Outstanding reliability and durability

APPLICATION

T4000 is most suitable for the adhesion to surface decorative sheet, rating plate and escutcheon, etc. made of metal and plastic material for the automobiles and household electric appliances.

T4000 is also recommendable for use as a double-faced permanent adhesive tape for various substrates.

Industrial Adhesive Tape T4000

SPECIFICATIONS

1. Holding strength at elevated temperatures

T4000 demonstrates an excellent holding strength even under severe conditions.

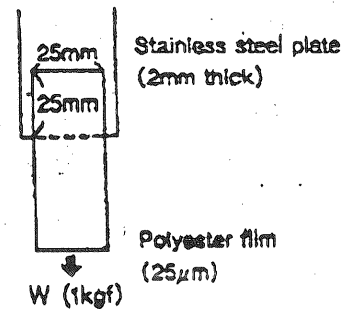
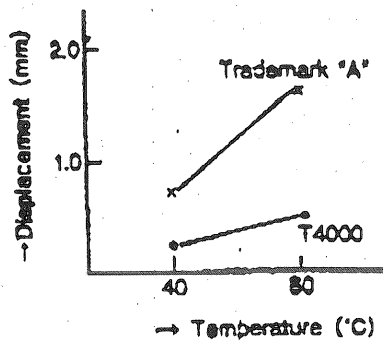

Conditions for preparing test pieces
 Temperature : 20°C
 Pressure : 2kgf/cm² (one stroke)
 Conditions for test peeling
 60minutes : 1kgf of loading

2. Temperature change of 180° peeling strength

T4000 provides a high bonding strength at various temperatures

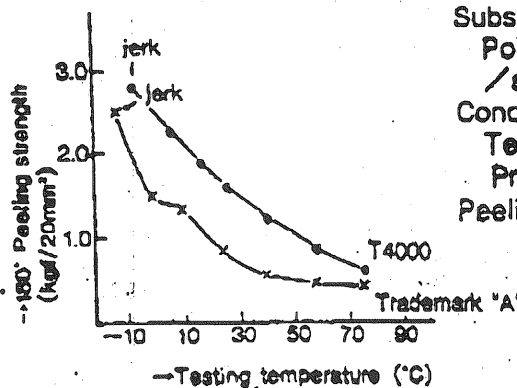

Substrate :
 Polyester film (25µm)
 / stainless steel plate (2mm thick)
 Conditions for preparing test pieces
 Temperature : 20°C
 Pressure : 2kgf/cm² (one stroke)
 Peeling speed : 300mm/min.

3. Peeling strength after aging

T4000 has excellent thermal aging resistance, and high resistances to moisture, water, oil and weather.

Substrate : Polyester film (25µm)/stainless steel plate (2mm thick)
 Conditions for preparing test pieces :
 Temperature : 20°C
 Pressure : 2kgf/cm² (one stroke)
 Test peeling speed : 300m/m