

FCC Test Report

Report No.: RF190916C10-4

FCC ID: I4L-LAVIEPM9560

Test Model: PC-PM75GNAR

Received Date: Sep. 16, 2019

Test Date: Oct. 03 ~ Oct. 08, 2019

Issued Date: Oct. 18, 2019

Applicant: Micro-Star International Co., Ltd.

Address: No. 69, Lide St., Zhonghe Dist., 235 New Taipei City Taiwan

Issued By: Bureau Veritas Consumer Products Services (H.K.) Ltd., Taoyuan Branch
Lin Kou Laboratories

Lab Address: No. 47-2, 14th Ling, Chia Pau Vil., Lin Kou Dist., New Taipei City, Taiwan

Test Location (1): No.19, Hwa Ya 2nd Rd., Wen Hwa Vil., Kwei Shan Dist., Taoyuan City
33383, Taiwan

Test Location (2): B2F., No.215, Sec. 3, Beixin Rd., Xindian Dist., New Taipei City 231, Taiwan

**FCC Registration /
Designation Number:** 427177 / TW0011



This report is for your exclusive use. Any copying or replication of this report to or for any other person or entity, or use of our name or trademark, is permitted only with our prior written permission. This report sets forth our findings solely with respect to the test samples identified herein. The results set forth in this report are not indicative or representative of the quality or characteristics of the lot from which a test sample was taken or any similar or identical product unless specifically and expressly noted. Our report includes all of the tests requested by you and the results thereof based upon the information that you provided to us. You have 60 days from date of issuance of this report to notify us of any material error or omission caused by our negligence, provided, however, that such notice shall be in writing and shall specifically address the issue you wish to raise. A failure to raise such issue within the prescribed time shall constitute your unqualified acceptance of the completeness of this report, the tests conducted and the correctness of the report contents. Unless specific mention, the uncertainty of measurement has been explicitly taken into account to declare the compliance or non-compliance to the specification. The report must not be used by the client to claim product certification, approval, or endorsement by TAF or any government agencies.

Table of Contents

Release Control Record	4
1 Certificate of Conformity	5
2 Summary of Test Results	6
2.1 Measurement Uncertainty	6
2.2 Modification Record	6
3 General Information	7
3.1 General Description of EUT	7
3.2 Description of Test Modes	9
3.2.1 Test Mode Applicability and Tested Channel Detail	12
3.3 Duty Cycle of Test Signal	14
3.4 Description of Support Units	15
3.4.1 Configuration of System under Test	15
3.5 General Description of Applied Standards	15
4 Test Types and Results	16
4.1 Radiated Emission and Bandedge Measurement	16
4.1.1 Limits of Radiated Emission and Bandedge Measurement	16
4.1.2 Limits of Unwanted Emission Out of the Restricted Bands	17
4.1.3 Test Instruments	18
4.1.4 Test Procedures	19
4.1.5 Deviation from Test Standard	20
4.1.6 Test Setup	20
4.1.7 EUT Operating Conditions	21
4.1.8 Test Results	22
4.2 Conducted Emission Measurement	67
4.2.1 Limits of Conducted Emission Measurement	67
4.2.2 Test Instruments	67
4.2.3 Test Procedures	68
4.2.4 Deviation from Test Standard	68
4.2.5 Test Setup	68
4.2.6 EUT Operating Conditions	68
4.2.7 Test Results	69
4.3 Transmit Power Measurement	71
4.3.1 Limits of Transmit Power Measurement	71
4.3.2 Test Setup	71
4.3.3 Test Instruments	72
4.3.4 Test Procedure	72
4.3.5 Deviation from Test Standard	72
4.3.6 EUT Operating Conditions	72
4.3.7 Test Results	73
4.4 Occupied Bandwidth Measurement	81
4.4.1 Test Setup	81
4.4.2 Test Instruments	81
4.4.3 Test Procedure	81
4.4.4 Test Results	82
4.5 Peak Power Spectral Density Measurement	88
4.5.1 Limits of Peak Power Spectral Density Measurement	88
4.5.2 Test Setup	88
4.5.3 Test Instruments	88
4.5.4 Test Procedures	88
4.5.5 Deviation from Test Standard	89
4.5.6 EUT Operating Conditions	89
4.5.7 Test Results	90
4.6 Frequency Stability	97

4.6.1	Limit of Frequency Stability Measurement	97
4.6.2	Test Setup	97
4.6.3	Test Instruments	97
4.6.4	Test Procedure	97
4.6.5	Deviation from Test Standard	97
4.6.6	EUT Operating Condition	97
4.6.7	Test Results	98
4.7	6 dB Bandwidth Measurement.....	99
4.7.1	Limits of 6 dB Bandwidth Measurement.....	99
4.7.2	Test Setup.....	99
4.7.3	Test Instruments	99
4.7.4	Test Procedure	99
4.7.5	Deviation from Test Standard	99
4.7.6	EUT Operating Condition	99
4.7.7	Test Results	100
5	Pictures of Test Arrangements.....	103
	Annex A- Radiated Out of Band Emission (OOBE) Measurement (For U-NII-3 band)	104
	Appendix – Information of the Testing Laboratories	107

Release Control Record

Issue No.	Description	Date Issued
RF190916C10-4	Original Release	Oct. 18, 2019

1 Certificate of Conformity

Product: Notebook

Brand: NEC Personal Computers, Ltd.

Test Model: PC-PM75GNAR

Sample Status: Mass product

Applicant: Micro-Star International Co., Ltd.

Test Date: Oct. 03 ~ Oct. 08, 2019

Standards: 47 CFR FCC Part 15, Subpart E (Section 15.407)
ANSI C63.10:2013

The above equipment has been tested by **Bureau Veritas Consumer Products Services (H.K.) Ltd., Taoyuan Branch**, and found compliance with the requirement of the above standards. The test record, data evaluation & Equipment Under Test (EUT) configurations represented herein are true and accurate accounts of the measurements of the sample's RF characteristics under the conditions specified in this report.

Prepared by : Gina Liu , **Date:** Oct. 18, 2019
Gina Liu / Specialist

Approved by : Dylan Chiou , **Date:** Oct. 18, 2019
Dylan Chiou / Project Engineer

2 Summary of Test Results

47 CFR FCC Part 15, Subpart E (Section 15.407)			
FCC Clause	Test Item	Result	Remarks
15.407(b)(6)	AC Power Conducted Emissions	Pass	Meet the requirement of limit. Minimum passing margin is -20.39 dB at 0.15225 MHz.
15.407(b) (1/2/3/4(i/ii)/6)	Radiated Emissions & Band Edge Measurement	Pass	Meet the requirement of limit. Minimum passing margin is -1.14 dB at 5150 MHz.
15.407(a)(1/2/3)	Max Average Transmit Power	Pass	Meet the requirement of limit.
---	Occupied Bandwidth Measurement	-	Reference only
15.407(a)(1/2/3)	Peak Power Spectral Density	Pass	Meet the requirement of limit.
15.407(e)	6 dB Bandwidth	Pass	Meet the requirement of limit. (U-NII-3 Band only)
15.407(g)	Frequency Stability	Pass	Meet the requirement of limit.
15.203	Antenna Requirement	Pass	No antenna connector is used.

Note:

- For U-NII-3 band compliance with rule part 15.407(b)(4)(i), the OOB test plots were recorded in Annex A.
- Determining compliance based on the results of the compliance measurement, not taking into account measurement instrumentation uncertainty.

2.1 Measurement Uncertainty

Where relevant, the following measurement uncertainty levels have been estimated for tests performed on the EUT as specified in CISPR 16-4-2:

Measurement	Frequency	Expanded Uncertainty (k=2) (±)
Conducted Emissions at mains ports	150 kHz ~ 30 MHz	2.94 dB
Radiated Emissions up to 1 GHz	9 kHz ~ 30 MHz	3.04 dB
	30 MHz ~ 200 MHz	2.0153 dB
	200 MHz ~ 1000 MHz	2.0224 dB
Radiated Emissions above 1 GHz	1 GHz ~ 18 GHz	1.0121 dB
	18 GHz ~ 40 GHz	1.1508 dB

2.2 Modification Record

There were no modifications required for compliance.

3 General Information

3.1 General Description of EUT

Product	Notebook
Brand	NEC Personal Computers, Ltd.
Test Model	PC-PM75GNAR
Status of EUT	Mass product
Power Supply Rating	20 / 15 / 9 / 5 Vdc (adapter) 3.84 / 11.52 Vdc (Li-ion battery)
Modulation Type	256QAM, 64QAM, 16QAM, QPSK, BPSK
Modulation Technology	OFDM
Transfer Rate	802.11a: 54.0/ 48.0/ 36.0/ 24.0/ 18.0/ 12.0/ 9.0/ 6.0 Mbps 802.11n: up to MCS7 802.11ac: up to MCS9
Operating Frequency	5180 ~ 5250 MHz, 5260 ~ 5320 MHz, 5500 ~ 5720 MHz, 5745 ~ 5825 MHz
Number of Channel	5180 ~ 5250 MHz: 4 for 802.11a, 802.11n (HT20), 802.11ac (VHT20) 2 for 802.11n (HT40), 802.11ac (VHT40) 1 for 802.11ac (VHT80) 1 for 802.11ac (VHT160) 5260 ~ 5320 MHz: 4 for 802.11a, 802.11n (HT20), 802.11ac (VHT20) 2 for 802.11n (HT40), 802.11ac (VHT40) 1 for 802.11ac (VHT80) 5500 ~ 5720 MHz: 11 for 802.11a, 12 for 802.11n (HT20), 802.11ac (VHT20) 6 for 802.11n (HT40), 802.11ac (VHT40) 3 for 802.11ac (VHT80) 1 for 802.11ac (VHT160) 5745 ~ 5825 MHz: 5 for 802.11a, 802.11n (HT20), 802.11ac (VHT20) 2 for 802.11n (HT40), 802.11ac (VHT40) 1 for 802.11ac (VHT80)
Output Power	137.088 mW for 5180 ~ 5250 MHz 133.352 mW for 5260 ~ 5320 MHz 139.812 mW for 5500 ~ 5720 MHz 220.107 mW for 5745 ~ 5825 MHz
Antenna Type	PIFA antenna with -1.67 dBi gain (5180 ~ 5250 MHz) PIFA antenna with -1.67 dBi gain (5260 ~ 5320 MHz) PIFA antenna with -1.01 dBi gain (5500 ~ 5720 MHz) PIFA antenna with -1.04 dBi gain (5745 ~ 5825 MHz)
Antenna Connector	N/A
Accessory Device	Refer to Note as below
Data Cable Supplied	Refer to Note as below

Note:

1. The EUT incorporates a MIMO function. Physically, the EUT provides two completed transmitters and two receivers.

Modulation Mode	Tx Function
802.11a	1TX
802.11n (HT20)	2TX
802.11n (HT40)	2TX
802.11ac (VHT20)	2TX
802.11ac (VHT40)	2TX
802.11ac (VHT80)	2TX
802.11ac (VHT160)	2TX

* The modulation and bandwidth are similar for 802.11n mode for HT20 / HT40 and 802.11ac mode for VHT20 / VHT40, therefore investigated worst case to representative mode in test report. (Final test mode refer section 3.2.1)

2. The EUT contains following accessory devices.

Product	Brand	Model	Description
Adapter	Lenovo	ADLX45YLC2D	I/P: 100-240 Vac, 50-60 Hz, 1.3 A O/P: 20 Vdc, 2.25 A; 15 Vdc, 3 A; 9 Vdc, 2 A; 5 Vdc, 2A
Battery	SIMPLO	945QA007H	SYS BATTERY PACK,LITHIUM-ION POLYMER,SMP/945QA007H,COSLIGHT/3.84V/3870MAH,3CELLS /3S1P,11.52V,3870MAH,CA485490G,BLACK,,13H1 FOR NEC- Hibiki,RoHS COMPLIANCE
CPU 1	Intel	Ci7-8565U(WHL-U)	w/ 8GB, w/ LTE/FPR connector
CPU 2	Intel	Ci5-8265U(WHL-U)	w/ 8GB, w/ LTE/FPR connector
CPU 3	Intel	Ci7-8565U(V0)	FOR NEC CONSIGN,CPU,WHISKEY LAKE,QUAD CORE i7-8565U,INTEL/CL8068404064407(QRY),1.8GHz,BGA-1528pin, 15W,V0 STEPPING/MM#999CN4,RoHS COMPLIANCE
CPU 4	Intel	Ci5-8265U(V0)	FOR NEC CONSIGN,CPU,WHISKEY LAKE,QUAD CORE i5--8265U,INTEL/CL8068404064608(QRZ0),1.6GHz,BGA-1528pin, 15W,V0 STEPPING/MM#999CN8,RoHS COMPLIANCE
WWAN Module	Intel	9560D2W	-

3. The above EUT information is declared by manufacturer and for more detailed features description, please refers to the manufacturer's specifications or user's manual.

3.2 Description of Test Modes

For 5180 ~ 5250 MHz

4 channels are provided for 802.11a, 802.11n (HT20), 802.11ac (VHT20):

Channel	Frequency (MHz)	Channel	Frequency (MHz)
36	5180	44	5220
40	5200	48	5240

2 channels are provided for 802.11n (HT40), 802.11ac (VHT40):

Channel	Frequency (MHz)	Channel	Frequency (MHz)
38	5190	46	5230

1 channel is provided for 802.11ac (VHT80):

Channel	Frequency (MHz)
42	5210

1 channel is provided for 802.11ac (VHT160):

Channel	Frequency (MHz)
50	5250

For 5260 ~ 5320 MHz

4 channels are provided for 802.11a, 802.11n (HT20), 802.11ac (VHT20):

Channel	Frequency (MHz)	Channel	Frequency (MHz)
52	5260	60	5300
56	5280	64	5320

2 channels are provided for 802.11n (HT40), 802.11ac (VHT40):

Channel	Frequency (MHz)	Channel	Frequency (MHz)
54	5270	62	5310

1 channel is provided for 802.11ac (VHT80):

Channel	Frequency (MHz)
58	5290

For 5500 ~ 5720 MHz

11 channels are provided for 802.11a

Channel	Frequency (MHz)	Channel	Frequency (MHz)
100	5500	124	5620
104	5520	128	5640
108	5540	132	5660
112	5560	136	5680
116	5580	140	5700
120	5600		

12 channels are provided for 802.11a, 802.11n (HT20), 802.11ac (VHT20):

Channel	Frequency (MHz)	Channel	Frequency (MHz)
100	5500	124	5620
104	5520	128	5640
108	5540	132	5660
112	5560	136	5680
116	5580	140	5700
120	5600	144	5720

6 channels are provided for 802.11n (HT40), 802.11ac (VHT40):

Channel	Frequency (MHz)	Channel	Frequency (MHz)
102	5510	126	5630
110	5550	134	5670
118	5590	142	5710

3 channels are provided for 802.11ac (VHT80):

Channel	Frequency (MHz)	Channel	Frequency (MHz)
106	5530	138	5690
122	5610		

1 channel is provided for 802.11ac (VHT160):

Channel	Frequency (MHz)
114	5570

For 5745 ~ 5825 MHz:

5 channels are provided for 802.11a, 802.11n (HT20), 802.11ac (VHT20):

Channel	Frequency (MHz)	Channel	Frequency (MHz)
149	5745	161	5805
153	5765	165	5825
157	5785		

2 channels are provided for 802.11n (HT40), 802.11ac (VHT40):

Channel	Frequency (MHz)	Channel	Frequency (MHz)
151	5755	159	5795

1 channel is provided for 802.11ac (VHT80):

Channel	Frequency (MHz)
155	5775

3.2.1 Test Mode Applicability and Tested Channel Detail

EUT Configure Mode	Applicable To				Description
	RE \geq 1G	RE $<$ 1G	PLC	APCM	
-	√	√	√	√	-

Where **RE \geq 1G**: Radiated Emission above 1 GHz

RE $<$ 1G: Radiated Emission below 1 GHz

PLC: Power Line Conducted Emission

APCM: Antenna Port Conducted Measurement

Note:

1. "-" means no effect.

Radiated Emission Test (Above 1 GHz):

Pre-Scan has been conducted to determine the worst-case mode from all possible combinations between available modulations, data rates and antenna ports (if EUT with antenna diversity architecture).

Following channel(s) was (were) selected for the final test as listed below.

EUT Configure Mode	Frequency Band (MHz)	Mode	Available Channel	Tested Channel	Modulation Technology	Modulation Type	Data Rate (Mbps)
-	5180-5250	802.11a	36 to 48	36, 40, 48	OFDM	BPSK	6.0
-		802.11n (HT20)	36 to 48	36, 40, 48	OFDM	BPSK	6.5
-		802.11n (HT40)	38 to 46	38, 46	OFDM	BPSK	13.5
-		802.11ac (VHT80)	42	42	OFDM	BPSK	29.3
-		802.11ac (VHT160)	50	50	OFDM	BPSK	58.5
-	5260-5320	802.11a	52 to 64	52, 60, 64	OFDM	BPSK	6.0
-		802.11n (HT20)	52 to 64	52, 60, 64	OFDM	BPSK	6.5
-		802.11n (HT40)	54 to 62	54, 62	OFDM	BPSK	13.5
-		802.11ac (VHT80)	58	58	OFDM	BPSK	29.3
-	5500-5720	802.11a	100 to 140	100, 116, 140	OFDM	BPSK	6.0
-		802.11n (HT20)	100 to 144	100, 116, 140, 144	OFDM	BPSK	6.5
-		802.11n (HT40)	102 to 142	102, 110, 134, 142	OFDM	BPSK	13.5
-		802.11ac (VHT80)	106 to 138	106, 122, 138	OFDM	BPSK	29.3
-		802.11ac (VHT160)	114	114	OFDM	BPSK	58.5
-	5745-5825	802.11a	149 to 165	149, 157, 165	OFDM	BPSK	6.0
-		802.11n (HT20)	149 to 165	149, 157, 165	OFDM	BPSK	6.5
-		802.11n (HT40)	151 to 159	151, 159	OFDM	BPSK	13.5
-		802.11ac (VHT80)	155	155	OFDM	BPSK	29.3

Radiated Emission Test (Below 1 GHz):

Pre-Scan has been conducted to determine the worst-case mode from all possible combinations between available modulations, data rates and antenna ports (if EUT with antenna diversity architecture).

Following channel(s) was (were) selected for the final test as listed below.

EUT Configure Mode	Frequency Band (MHz)	Mode	Available Channel	Tested Channel	Modulation Technology	Modulation Type	Data Rate (Mbps)
-	5180-5250	802.11n (HT40)	38 to 46	38	OFDM	BPSK	13.5

Power Line Conducted Emission Test:

- Pre-Scan has been conducted to determine the worst-case mode from all possible combinations between available modulations, data rates and antenna ports (if EUT with antenna diversity architecture).
- Following channel(s) was (were) selected for the final test as listed below.

EUT Configure Mode	Frequency Band (MHz)	Mode	Available Channel	Tested Channel	Modulation Technology	Modulation Type	Data Rate (Mbps)
-	5180-5250	802.11n (HT40)	38 to 46	38	OFDM	BPSK	13.5

Antenna Port Conducted Measurement:

- This item includes all test value of each mode, but only includes spectrum plot of worst value of each mode.
- Pre-Scan has been conducted to determine the worst-case mode from all possible combinations between available modulations, data rates and antenna ports (if EUT with antenna diversity architecture).
- Following channel(s) was (were) selected for the final test as listed below.

EUT Configure Mode	Frequency Band (MHz)	Mode	Available Channel	Tested Channel	Modulation Technology	Modulation Type	Data Rate (Mbps)
-	5180-5250	802.11a	36 to 48	36, 40, 48	OFDM	BPSK	6.0
-		802.11n (HT20)	36 to 48	36, 40, 48	OFDM	BPSK	6.5
-		802.11n (HT40)	38 to 46	38, 46	OFDM	BPSK	13.5
-		802.11ac (VHT80)	42	42	OFDM	BPSK	29.3
-		802.11ac (VHT160)	50	50	OFDM	BPSK	58.5
-	5260-5320	802.11a	52 to 64	52, 60, 64	OFDM	BPSK	6.0
-		802.11n (HT20)	52 to 64	52, 60, 64	OFDM	BPSK	6.5
-		802.11n (HT40)	54 to 62	54, 62	OFDM	BPSK	13.5
-		802.11ac (VHT80)	58	58	OFDM	BPSK	29.3
-	5500-5720	802.11a	100 to 140	100, 116, 140	OFDM	BPSK	6.0
-		802.11n (HT20)	100 to 144	100, 116, 140, 144	OFDM	BPSK	6.5
-		802.11n (HT40)	102 to 142	102, 110, 134, 142	OFDM	BPSK	13.5
-		802.11ac (VHT80)	106 to 138	106, 122, 138	OFDM	BPSK	29.3
-		802.11ac (VHT160)	114	114	OFDM	BPSK	58.5
-	5745-5825	802.11a	149 to 165	149, 157, 165	OFDM	BPSK	6.0
-		802.11n (HT20)	149 to 165	149, 157, 165	OFDM	BPSK	6.5
-		802.11n (HT40)	151 to 159	151, 159	OFDM	BPSK	13.5
-		802.11ac (VHT80)	155	155	OFDM	BPSK	29.3

Test Condition:

Applicable To	Environmental Conditions	Input Power	Tested by
RE \geq 1G	25 deg. C, 65 % RH	120 Vac, 60 Hz	Charles Hsiao, Harry Hsueh, Karl Lee,
RE<1G	25 deg. C, 65 % RH	120 Vac, 60 Hz	Charles Hsiao
PLC	25 deg. C, 65 % RH	120 Vac, 60 Hz	Anson Lin
APCM	25 deg. C, 65 % RH	11.52 Vdc	Wayne Lin

3.3 Duty Cycle of Test Signal

MODULATION TYPE: BPSK

802.11a: Duty cycle = $2.045/2.089 = 0.979$, Duty factor = $10 * \log(1/0.979) = 0.09$

802.11n (HT20): Duty cycle = $1.906/1.949 = 0.978$, Duty factor = $10 * \log(1/0.978) = 0.10$

802.11n (HT40): Duty cycle = $0.935/0.978 = 0.956$, Duty factor = $10 * \log(1/0.956) = 0.20$

802.11ac (VHT80): Duty cycle = $0.459/0.501 = 0.916$, Duty factor = $10 * \log(1/0.916) = 0.38$

802.11ac (VHT160): Duty cycle = $0.251/0.293 = 0.857$, Duty factor = $10 * \log(1/0.857) = 0.67$

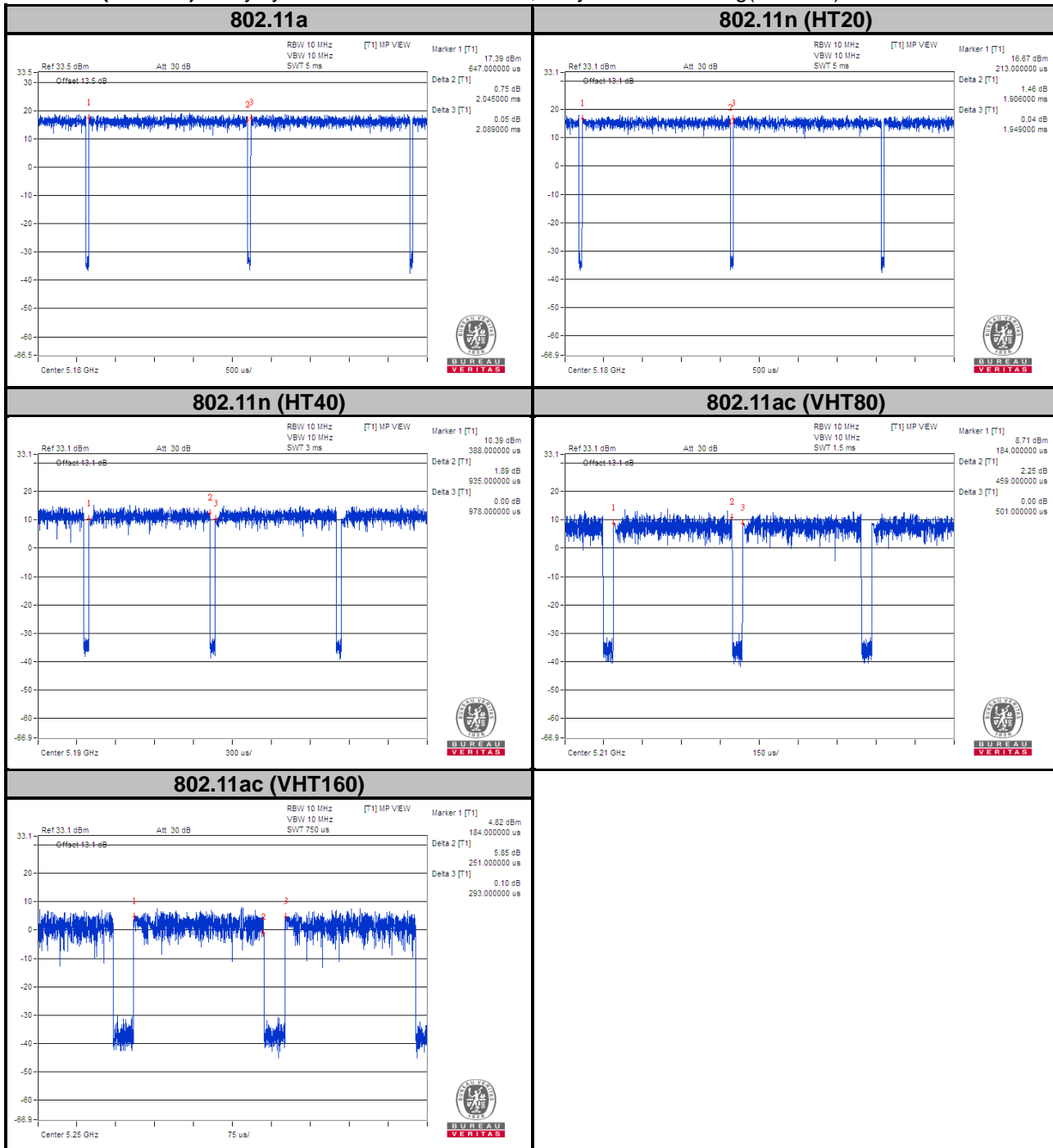

3.4 Description of Support Units

The EUT has been tested as an independent unit together with other necessary accessories or support units.

3.4.1 Configuration of System under Test

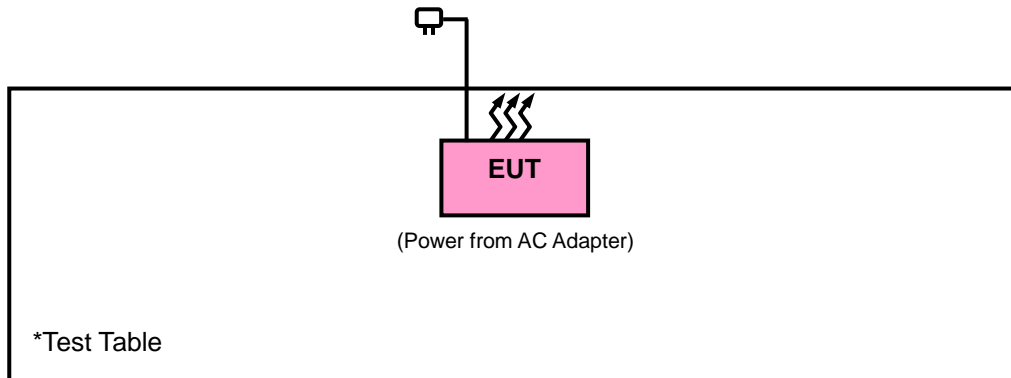

3.5 General Description of Applied Standards

The EUT is a RF Product. According to the specifications of the manufacturer, it must comply with the requirements of the following standards:

FCC Part 15, Subpart E (15.407)

KDB 789033 D02 General UNII Test Procedures New Rules v02r01

KDB 662911 D01 Multiple Transmitter Output v02r01

ANSI C63.10-2013

All test items have been performed and recorded as per the above standards.

4 Test Types and Results

4.1 Radiated Emission and Bandedge Measurement

4.1.1 Limits of Radiated Emission and Bandedge Measurement

Radiated emissions which fall in the restricted bands must comply with the radiated emission limits specified as below table.

Frequencies (MHz)	Field Strength (microvolts/meter)	Measurement Distance (meters)
0.009 ~ 0.490	2400/F (kHz)	300
0.490 ~ 1.705	24000/F (kHz)	30
1.705 ~ 30.0	30	30
30 ~ 88	100	3
88 ~ 216	150	3
216 ~ 960	200	3
Above 960	500	3

Note:

1. The lower limit shall apply at the transition frequencies.
2. Emission level (dBuV/m) = 20 log Emission level (uV/m).
3. For frequencies above 1000 MHz, the field strength limits are based on average detector, however, the peak field strength of any emission shall not exceed the maximum permitted average limits, specified above by more than 20 dB under any condition of modulation.

4.1.2 Limits of Unwanted Emission Out of the Restricted Bands

Applicable To		Limit	
789033 D02 General UNII Test Procedures New Rules v02r01		Field Strength at 3 m	
		PK: 74 (dBµV/m)	AV: 54 (dBµV/m)
Frequency Band	Applicable To	EIRP Limit	Equivalent Field Strength at 3 m
5150~5250 MHz	15.407(b)(1)	PK: -27 (dBm/MHz)	PK: 68.2 (dBµV/m)
5250~5350 MHz	15.407(b)(2)		
5470~5725 MHz	15.407(b)(3)		
5725~5850 MHz	<input checked="" type="checkbox"/> 15.407(b)(4)(i)	PK:-27 (dBm/MHz) ^{*1} PK:10 (dBm/MHz) ^{*2} PK:15.6 (dBm/MHz) ^{*3} PK:27 (dBm/MHz) ^{*4}	PK: 68.2 (dBµV/m) ^{*1} PK:105.2 (dBµV/m) ^{*2} PK: 110.8 (dBµV/m) ^{*3} PK:122.2 (dBµV/m) ^{*4}
	<input type="checkbox"/> 15.407(b)(4)(ii)	Emission limits in section 15.247(d)	

^{*1} beyond 75 MHz or more above of the band edge.

^{*2} below the band edge increasing linearly to 10 dBm/MHz at 25 MHz above.

^{*3} below the band edge increasing linearly to a level of 15.6 dBm/MHz at 5 MHz above.

^{*4} from 5 MHz above or below the band edge increasing linearly to a level of 27 dBm/MHz at the band edge.

Note:

The following formula is used to convert the equipment isotropic radiated power (eirp) to field strength:

$$E = \frac{1000000\sqrt{30P}}{3} \mu\text{V/m, where } P \text{ is the eirp (Watts).}$$

4.1.3 Test Instruments

Description & Manufacturer	Model No.	Serial No.	Date of Calibration	Due Date of Calibration
Test Receiver Agilent Technologies	N9038A	MY52260177	Aug. 26, 2019	Aug. 25, 2020
Spectrum Analyzer ROHDE & SCHWARZ	FSU43	101261	Apr. 15, 2019	Apr. 14, 2020
BILOG Antenna SCHWARZBECK	VULB 9168	9168-616	Nov. 27, 2018	Nov. 26, 2019
HORN Antenna ETS-Lindgren	3117	00143293	Nov. 25, 2018	Nov. 24, 2019
HORN Antenna SCHWARZBECK	BBHA 9170	9170-480	Nov. 25, 2018	Nov. 24, 2019
Fixed Attenuator Mini-Circuits	MDCS18N-10	MDCS18N-10-01	Apr. 15, 2019	Apr. 14, 2020
Loop Antenna	HLA 6121	45745	Jul. 01, 2019	Jun. 30, 2020
Preamplifier Agilent	310N	187226	Jun. 18, 2019	Jun. 17, 2020
Preamplifier Agilent	83017A	MY39501357	Jun. 18, 2019	Jun. 17, 2020
Power Meter Anritsu	ML2495A	1012010	Sep. 04, 2019	Sep. 03, 2020
Power Sensor Anritsu	MA2411B	1315050	Sep. 04, 2019	Sep. 03, 2020
RF signal cable ETS-LINDGREN	5D-FB	Cable-CH1-01(RFC -SMS-100-SMS-12 0+RFC-SMS-100-S MS-400)	Jun. 18, 2019	Jun. 17, 2020
RF signal cable ETS-LINDGREN	8D-FB	Cable-CH1-02(RFC -SMS-100-SMS-24)	Jun. 18, 2019	Jun. 17, 2020
Software BV ADT	E3 8.130425b	NA	NA	NA
Antenna Tower MF	NA	NA	NA	NA
Turn Table MF	NA	NA	NA	NA
Antenna Tower & Turn Table Controller MF	MF-7802	NA	NA	NA

- Note: 1. The calibration interval of the above test instruments is 12 months and the calibrations are traceable to NML/ROC and NIST/USA.
2. The test was performed in HsinTien Chamber 1.

4.1.4 Test Procedures

For Radiated Emission below 30 MHz

- a. The EUT was placed on the top of a rotating table 0.8 meters above the ground at a 3 meter chamber room. The table was rotated 360 degrees to determine the position of the highest radiation.
- b. The EUT was set 3 meters away from the interference-receiving antenna, which was mounted on the top of a variable-height antenna tower.
- c. Both Parallel, perpendicular, and ground-parallel orientations of the antenna are set to make the measurement.
- d. For each suspected emission, the EUT was arranged to its worst case and the rotatable table was turned from 0 degrees to 360 degrees to find the maximum reading.
- e. The test-receiver system was set to Quasi-Peak Detect Function and Specified Bandwidth with Maximum Hold Mode.

Note:

1. The resolution bandwidth and video bandwidth of test receiver/spectrum analyzer is 9 kHz at frequency below 30 MHz.

For Radiated Emission above 30 MHz

- a. The EUT was placed on the top of a rotating table 0.8 meters (for 30 MHz ~ 1 GHz) / 1.5 meters (for above 1 GHz) above the ground at 3 meter chamber room for test. The table was rotated 360 degrees to determine the position of the highest radiation.
- b. The EUT was set 3 meters away from the interference-receiving antenna, which was mounted on the top of a variable-height antenna tower.
- c. The height of antenna is varied from one meter to four meters above the ground to determine the maximum value of the field strength. Both horizontal and vertical polarizations of the antenna are set to make the measurement.
- d. For each suspected emission, the EUT was arranged to its worst case and then the antenna was tuned to heights from 1 meter to 4 meters and the rotatable table was turned from 0 degrees to 360 degrees to find the maximum reading.
- e. The test-receiver system was set to quasi-peak detect function and specified bandwidth with maximum hold mode when the test frequency is below 1 GHz.
- f. The test-receiver system was set to peak and average detected function and specified bandwidth with maximum hold mode when the test frequency is above 1 GHz. If the peak reading value also meets average limit, measurement with the average detector is unnecessary.

Note:

1. The resolution bandwidth and video bandwidth of test receiver/spectrum analyzer is 120 kHz for Quasi-peak detection (QP) or Peak detection (PK) at frequency below 1 GHz.
2. The resolution bandwidth of test receiver/spectrum analyzer is 1 MHz and the video bandwidth is 3 MHz for Peak detection (PK) at frequency above 1 GHz.
3. The resolution bandwidth of test receiver/spectrum analyzer is 1 MHz and the video bandwidth is $\geq 1/T$ (Duty cycle < 98 %) or 10 Hz (Duty cycle ≥ 98 %) for Average detection (AV) at frequency above 1 GHz.
(11a: RBW = 1 MHz, VBW = 1 kHz ; 11n (HT20): RBW = 1 MHz, VBW = 1 kHz ;
11n (HT40): RBW = 1 MHz, VBW = 2 kHz ; 11ac (VHT80): RBW = 1 MHz, VBW = 5 kHz; 11ac (VHT160): RBW = 1 MHz, VBW = 8 kHz)
4. All modes of operation were investigated and the worst-case emissions are reported.

4.1.5 Deviation from Test Standard

No deviation.

4.1.6 Test Setup

<Radiated Emission below 30 MHz>

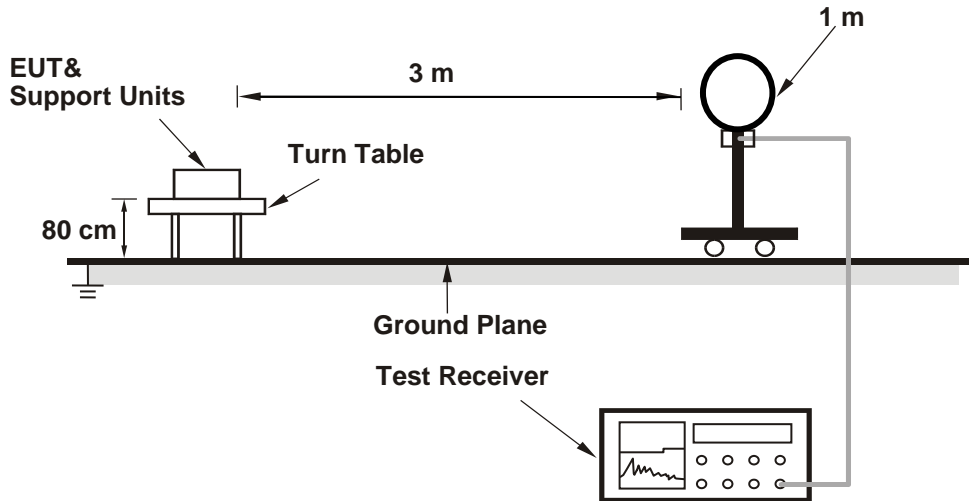

<Radiated Emission 30 MHz to 1 GHz>

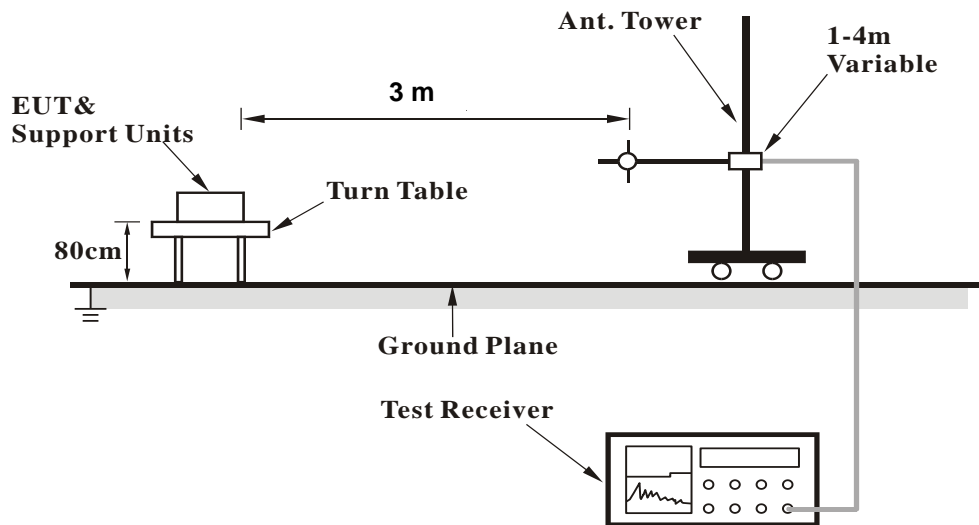

<Radiated Emission above 1 GHz>

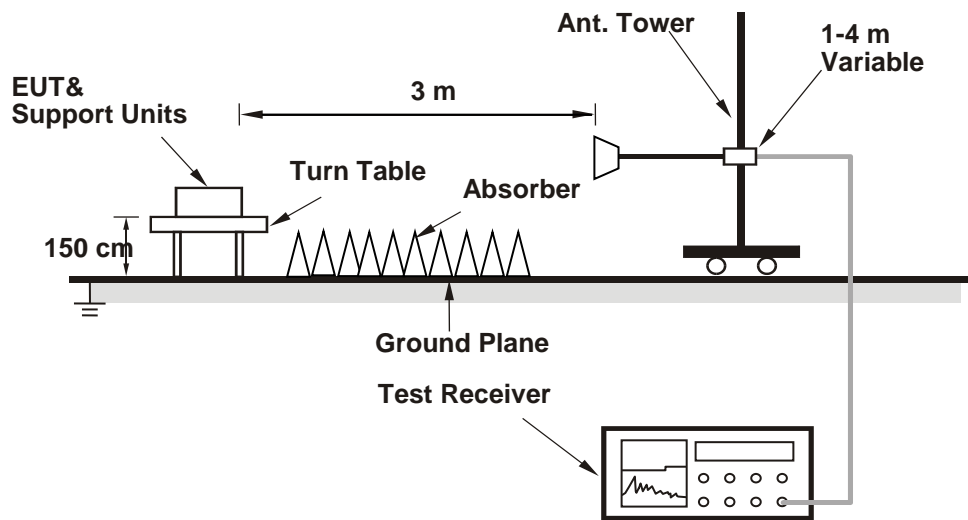

For the actual test configuration, please refer to the attached file (Test Setup Photo).

4.1.7 EUT Operating Conditions

- a. Placed the EUT on a testing table.
- b. Use the software to control the EUT under transmission condition continuously at specific channel frequency.

4.1.8 Test Results
Above 1 GHz Data :
802.11a

EUT Test Condition		Measurement Detail	
Channel	Channel 36	Frequency Range	1 GHz ~ 40 GHz
Input Power	120 Vac, 60 Hz	Detector Function	Peak (PK) Average (AV)
Environmental Conditions	25 deg. C, 65 % RH	Tested By	Charles Hsiao

Antenna Polarity & Test Distance: Horizontal at 3 m								
Frequency (MHz)	Emission Level (dBuV/m)	Read Level (dBuV)	Factor (dB/m)	Limit (dBuV/m)	Margin (dB)	Antenna Height (cm)	Table Angle (Degree)	Remark
5148.65	43.88	33.83	10.05	54	-10.12	192	187	Average
5148.65	54.01	43.96	10.05	74	-19.99	192	187	Peak
5180	98.56	88.44	10.12			192	187	Average
5180	105.87	95.75	10.12			192	187	Peak
*10360	53.63	37.61	16.02	68.2	-14.57	129	234	Peak

Antenna Polarity & Test Distance: Vertical at 3 m								
Frequency (MHz)	Emission Level (dBuV/m)	Read Level (dBuV)	Factor (dB/m)	Limit (dBuV/m)	Margin (dB)	Antenna Height (cm)	Table Angle (Degree)	Remark
5148.2	42.85	32.8	10.05	54	-11.15	100	272	Average
5148.2	53.79	43.74	10.05	74	-20.21	100	272	Peak
5180	97.17	87.05	10.12			100	272	Average
5180	104.33	94.21	10.12			100	272	Peak
*10360	54.08	38.06	16.02	68.2	-14.12	146	118	Peak

Remarks:

- Emission Level = Read Level + Factor
Margin value = Emission level – Limit value
- 5180 MHz: Fundamental Frequency
- *: Out of Restricted Band
- The emission levels of other frequencies were very low against the limit

EUT Test Condition		Measurement Detail	
Channel	Channel 40	Frequency Range	1 GHz ~ 40 GHz
Input Power	120 Vac, 60 Hz	Detector Function	Peak (PK) Average (AV)
Environmental Conditions	25 deg. C, 65 % RH	Tested By	Charles Hsiao

Antenna Polarity & Test Distance: Horizontal at 3 m								
Frequency (MHz)	Emission Level (dBuV/m)	Read Level (dBuV)	Factor (dB/m)	Limit (dBuV/m)	Margin (dB)	Antenna Height (cm)	Table Angle (Degree)	Remark
5150	45.4	35.35	10.05	54	-8.6	192	187	Average
5150	56.83	46.78	10.05	74	-17.17	192	187	Peak
5200	100.28	90.12	10.16			192	187	Average
5200	107	96.84	10.16			192	187	Peak
5351.65	42.04	31.81	10.23	54	-11.96	192	187	Average
5351.65	52.78	42.55	10.23	74	-21.22	192	187	Peak
*10400	53.46	37.28	16.18	68.2	-14.74	168	204	Peak
Antenna Polarity & Test Distance: Vertical at 3 m								
Frequency (MHz)	Emission Level (dBuV/m)	Read Level (dBuV)	Factor (dB/m)	Limit (dBuV/m)	Margin (dB)	Antenna Height (cm)	Table Angle (Degree)	Remark
5150	43.47	33.42	10.05	54	-10.53	100	272	Average
5150	54.14	44.09	10.05	74	-19.86	100	272	Peak
5200	99.67	89.51	10.16			100	272	Average
5200	106.48	96.32	10.16			100	272	Peak
5444.27	41.78	31.3	10.48	54	-12.22	100	272	Average
5444.27	52.64	42.16	10.48	74	-21.36	100	272	Peak
*10400	53.9	37.72	16.18	68.2	-14.3	151	126	Peak

Remarks:

- Emission Level = Read Level + Factor
Margin value = Emission level – Limit value
- 5200 MHz: Fundamental Frequency
- *: Out of Restricted Band
- The emission levels of other frequencies were very low against the limit

EUT Test Condition		Measurement Detail	
Channel	Channel 48	Frequency Range	1 GHz ~ 40 GHz
Input Power	120 Vac, 60 Hz	Detector Function	Peak (PK) Average (AV)
Environmental Conditions	25 deg. C, 65 % RH	Tested By	Charles Hsiao

Antenna Polarity & Test Distance: Horizontal at 3 m								
Frequency (MHz)	Emission Level (dBuV/m)	Read Level (dBuV)	Factor (dB/m)	Limit (dBuV/m)	Margin (dB)	Antenna Height (cm)	Table Angle (Degree)	Remark
5240	100.49	90.35	10.14			192	187	Average
5240	107.59	97.45	10.14			192	187	Peak
5435.36	41.76	31.28	10.48	54	-12.24	192	187	Average
5435.36	52.82	42.34	10.48	74	-21.18	192	187	Peak
*10480	53.93	38.03	15.9	68.2	-14.27	163	216	Peak
Antenna Polarity & Test Distance: Vertical at 3 m								
Frequency (MHz)	Emission Level (dBuV/m)	Read Level (dBuV)	Factor (dB/m)	Limit (dBuV/m)	Margin (dB)	Antenna Height (cm)	Table Angle (Degree)	Remark
5240	99.5	89.36	10.14			100	272	Average
5240	106.1	95.96	10.14			100	272	Peak
5459.56	41.92	31.41	10.51	54	-12.08	100	272	Average
5459.56	52.34	41.83	10.51	74	-21.66	100	272	Peak
*10480	54.85	38.95	15.9	68.2	-13.35	159	211	Peak

Remarks:

- Emission Level = Read Level + Factor
Margin value = Emission level – Limit value
- 5240 MHz: Fundamental Frequency
- *: Out of Restricted Band
- The emission levels of other frequencies were very low against the limit

EUT Test Condition		Measurement Detail	
Channel	Channel 52	Frequency Range	1 GHz ~ 40 GHz
Input Power	120 Vac, 60 Hz	Detector Function	Peak (PK) Average (AV)
Environmental Conditions	25 deg. C, 65 % RH	Tested By	Charles Hsiao

Antenna Polarity & Test Distance: Horizontal at 3 m								
Frequency (MHz)	Emission Level (dBuV/m)	Read Level (dBuV)	Factor (dB/m)	Limit (dBuV/m)	Margin (dB)	Antenna Height (cm)	Table Angle (Degree)	Remark
5120.15	42.19	32.22	9.97	54	-11.81	195	332	Average
5120.15	52.59	42.62	9.97	74	-21.41	195	332	Peak
5260	100.37	90.25	10.12			195	332	Average
5260	107.56	97.44	10.12			195	332	Peak
*10520	54.32	38.44	15.88	68.2	-13.88	186	230	Peak

Antenna Polarity & Test Distance: Vertical at 3 m								
Frequency (MHz)	Emission Level (dBuV/m)	Read Level (dBuV)	Factor (dB/m)	Limit (dBuV/m)	Margin (dB)	Antenna Height (cm)	Table Angle (Degree)	Remark
5120	42.32	32.35	9.97	54	-11.68	194	269	Average
5120	52.94	42.97	9.97	74	-21.06	194	269	Peak
5260	102.37	92.25	10.12			194	269	Average
5260	109.38	99.26	10.12			194	269	Peak
*10520	53.77	37.89	15.88	68.2	-14.43	121	18	Peak

Remarks:

- Emission Level = Read Level + Factor
Margin value = Emission level – Limit value
- 5260 MHz: Fundamental Frequency
- *: Out of Restricted Band
- The emission levels of other frequencies were very low against the limit

EUT Test Condition		Measurement Detail	
Channel	Channel 60	Frequency Range	1 GHz ~ 40 GHz
Input Power	120 Vac, 60 Hz	Detector Function	Peak (PK) Average (AV)
Environmental Conditions	25 deg. C, 65 % RH	Tested By	Charles Hsiao

Antenna Polarity & Test Distance: Horizontal at 3 m								
Frequency (MHz)	Emission Level (dBuV/m)	Read Level (dBuV)	Factor (dB/m)	Limit (dBuV/m)	Margin (dB)	Antenna Height (cm)	Table Angle (Degree)	Remark
5120	42.28	32.31	9.97	54	-11.72	195	332	Average
5120	52.25	42.28	9.97	74	-21.75	195	332	Peak
5300	100.28	90.22	10.06			195	332	Average
5300	107.7	97.64	10.06			195	332	Peak
5350	48.13	37.9	10.23	54	-5.87	195	332	Average
5350	59.75	49.52	10.23	74	-14.25	195	332	Peak
10600	43.14	27.38	15.76	54	-10.86	145	218	Average
10600	52.88	37.12	15.76	74	-21.12	145	218	Peak

Antenna Polarity & Test Distance: Vertical at 3 m								
Frequency (MHz)	Emission Level (dBuV/m)	Read Level (dBuV)	Factor (dB/m)	Limit (dBuV/m)	Margin (dB)	Antenna Height (cm)	Table Angle (Degree)	Remark
5120	42.36	32.39	9.97	54	-11.64	194	269	Average
5120	52.07	42.1	9.97	74	-21.93	194	269	Peak
5300	102.41	92.35	10.06			194	269	Average
5300	109.22	99.16	10.06			194	269	Peak
5350	51.02	40.79	10.23	54	-2.98	194	269	Average
5350	62.06	51.83	10.23	74	-11.94	194	269	Peak
10600	44.62	28.86	15.76	54	-9.38	141	68	Average
10600	54.07	38.31	15.76	74	-19.93	141	68	Peak

Remarks:

- Emission Level = Read Level + Factor
Margin value = Emission level – Limit value
- 5300 MHz: Fundamental Frequency
- *: Out of Restricted Band
- The emission levels of other frequencies were very low against the limit

EUT Test Condition		Measurement Detail	
Channel	Channel 64	Frequency Range	1 GHz ~ 40 GHz
Input Power	120 Vac, 60 Hz	Detector Function	Peak (PK) Average (AV)
Environmental Conditions	25 deg. C, 65 % RH	Tested By	Charles Hsiao

Antenna Polarity & Test Distance: Horizontal at 3 m								
Frequency (MHz)	Emission Level (dBuV/m)	Read Level (dBuV)	Factor (dB/m)	Limit (dBuV/m)	Margin (dB)	Antenna Height (cm)	Table Angle (Degree)	Remark
5320	96.33	86.24	10.09			195	332	Average
5320	103.64	93.55	10.09			195	332	Peak
5350.99	44.48	34.25	10.23	54	-9.52	195	332	Average
5350.99	55.7	45.47	10.23	74	-18.3	195	332	Peak
10640	43.94	27.95	15.99	54	-10.06	195	304	Average
10640	53.6	37.61	15.99	74	-20.4	195	304	Peak
Antenna Polarity & Test Distance: Vertical at 3 m								
Frequency (MHz)	Emission Level (dBuV/m)	Read Level (dBuV)	Factor (dB/m)	Limit (dBuV/m)	Margin (dB)	Antenna Height (cm)	Table Angle (Degree)	Remark
5320	96.33	86.24	10.09			195	332	Average
5320	103.64	93.55	10.09			195	332	Peak
5350.99	44.48	34.25	10.23	54	-9.52	195	332	Average
5350.99	55.7	45.47	10.23	74	-18.3	195	332	Peak
10640	43.94	27.95	15.99	54	-10.06	195	304	Average
10640	53.6	37.61	15.99	74	-20.4	195	304	Peak

Remarks:

1. Emission Level = Read Level + Factor
Margin value = Emission level – Limit value
2. 5320 MHz: Fundamental Frequency
3. *: Out of Restricted Band
4. The emission levels of other frequencies were very low against the limit

EUT Test Condition		Measurement Detail	
Channel	Channel 100	Frequency Range	1 GHz ~ 40 GHz
Input Power	120 Vac, 60 Hz	Detector Function	Peak (PK) Average (AV)
Environmental Conditions	25 deg. C, 65 % RH	Tested By	Charles Hsiao

Antenna Polarity & Test Distance: Horizontal at 3 m								
Frequency (MHz)	Emission Level (dBuV/m)	Read Level (dBuV)	Factor (dB/m)	Limit (dBuV/m)	Margin (dB)	Antenna Height (cm)	Table Angle (Degree)	Remark
5460	42.1	31.59	10.51	54	-11.9	168	215	Average
5460	53.11	42.6	10.51	74	-20.89	168	215	Peak
*5469.68	53.91	43.38	10.53	68.2	-14.29	168	215	Peak
5500	96.46	85.86	10.6			168	215	Average
5500	103.16	92.56	10.6			168	215	Peak
11000	44.14	28.01	16.13	54	-9.86	172	169	Average
11000	53.78	37.65	16.13	74	-20.22	172	169	Peak
Antenna Polarity & Test Distance: Vertical at 3 m								
Frequency (MHz)	Emission Level (dBuV/m)	Read Level (dBuV)	Factor (dB/m)	Limit (dBuV/m)	Margin (dB)	Antenna Height (cm)	Table Angle (Degree)	Remark
5455.6	43.74	33.23	10.51	54	-10.26	183	273	Average
5455.6	54.16	43.65	10.51	74	-19.84	183	273	Peak
*5469.36	54.5	43.97	10.53	68.2	-13.7	183	273	Peak
5500	99.57	88.97	10.6			183	273	Average
5500	106.19	95.59	10.6			183	273	Peak
11000	44.86	28.73	16.13	54	-9.14	147	125	Average
11000	54.36	38.23	16.13	74	-19.64	147	125	Peak

Remarks:

- Emission Level = Read Level + Factor
Margin value = Emission level – Limit value
- 5500 MHz: Fundamental Frequency
- *: Out of Restricted Band
- The emission levels of other frequencies were very low against the limit

EUT Test Condition		Measurement Detail	
Channel	Channel 116	Frequency Range	1 GHz ~ 40 GHz
Input Power	120 Vac, 60 Hz	Detector Function	Peak (PK) Average (AV)
Environmental Conditions	25 deg. C, 65 % RH	Tested By	Charles Hsiao

Antenna Polarity & Test Distance: Horizontal at 3 m								
Frequency (MHz)	Emission Level (dBuV/m)	Read Level (dBuV)	Factor (dB/m)	Limit (dBuV/m)	Margin (dB)	Antenna Height (cm)	Table Angle (Degree)	Remark
5451.12	41.83	31.32	10.51	54	-12.17	168	215	Average
5451.12	52.55	42.04	10.51	74	-21.45	168	215	Peak
*5469.04	49.95	39.42	10.53	68.2	-18.25	168	215	Peak
5580	96.11	85.4	10.71			168	215	Average
5580	103.78	93.07	10.71			168	215	Peak
*5725.88	52.74	41.82	10.92	68.2	-15.46	168	215	Peak
11160	47.28	30.92	16.36	54	-6.72	185	232	Average
11160	56.67	40.31	16.36	74	-17.33	185	232	Peak
Antenna Polarity & Test Distance: Vertical at 3 m								
Frequency (MHz)	Emission Level (dBuV/m)	Read Level (dBuV)	Factor (dB/m)	Limit (dBuV/m)	Margin (dB)	Antenna Height (cm)	Table Angle (Degree)	Remark
5458.96	42.18	31.67	10.51	54	-11.82	183	273	Average
5458.96	52.18	41.67	10.51	74	-21.82	183	273	Peak
*5469.04	51.19	40.66	10.53	68.2	-17.01	183	273	Peak
5580	99.37	88.66	10.71			183	273	Average
5580	106.71	96	10.71			183	273	Peak
*5725.56	51.75	40.83	10.92	68.2	-16.45	183	273	Peak
11160	47.16	30.8	16.36	54	-6.84	187	124	Average
11160	56.65	40.29	16.36	74	-17.35	187	124	Peak

Remarks:

- Emission Level = Read Level + Factor
Margin value = Emission level – Limit value
- 5580 MHz: Fundamental Frequency
- *: Out of Restricted Band
- The emission levels of other frequencies were very low against the limit

EUT Test Condition		Measurement Detail	
Channel	Channel 140	Frequency Range	1 GHz ~ 40 GHz
Input Power	120 Vac, 60 Hz	Detector Function	Peak (PK) Average (AV)
Environmental Conditions	25 deg. C, 65 % RH	Tested By	Charles Hsiao

Antenna Polarity & Test Distance: Horizontal at 3 m								
Frequency (MHz)	Emission Level (dBuV/m)	Read Level (dBuV)	Factor (dB/m)	Limit (dBuV/m)	Margin (dB)	Antenna Height (cm)	Table Angle (Degree)	Remark
5700	98.72	87.77	10.95			168	215	Average
5700	105.3	94.35	10.95			168	215	Peak
*5725.08	56.38	45.46	10.92	68.2	-11.82	168	215	Peak
11400	45.27	29.08	16.19	54	-8.73	159	235	Average
11400	54.76	38.57	16.19	74	-19.24	159	235	Peak
Antenna Polarity & Test Distance: Vertical at 3 m								
Frequency (MHz)	Emission Level (dBuV/m)	Read Level (dBuV)	Factor (dB/m)	Limit (dBuV/m)	Margin (dB)	Antenna Height (cm)	Table Angle (Degree)	Remark
5700	101.93	90.98	10.95			183	273	Average
5700	108.28	97.33	10.95			183	273	Peak
*5725	60.61	49.69	10.92	68.2	-7.59	183	273	Peak
11400	46.67	30.48	16.19	54	-7.33	175	148	Average
11400	56.05	39.86	16.19	74	-17.95	175	148	Peak

Remarks:

- Emission Level = Read Level + Factor
Margin value = Emission level – Limit value
- 5700 MHz: Fundamental Frequency
- *: Out of Restricted Band
- The emission levels of other frequencies were very low against the limit

EUT Test Condition		Measurement Detail	
Channel	Channel 149	Frequency Range	1 GHz ~ 40 GHz
Input Power	120 Vac, 60 Hz	Detector Function	Peak (PK) Average (AV)
Environmental Conditions	25 deg. C, 65 % RH	Tested By	Charles Hsiao

<Spurious Emission>

Antenna Polarity & Test Distance: Horizontal at 3 m								
Frequency (MHz)	Emission Level (dBuV/m)	Read Level (dBuV)	Factor (dB/m)	Limit (dBuV/m)	Margin (dB)	Antenna Height (cm)	Table Angle (Degree)	Remark
5745	101.43	90.55	10.88			142	232	Average
5745	108.37	97.49	10.88			142	232	Peak
11490	46.37	29.9	16.47	54	-7.63	185	164	Average
11490	55.77	39.3	16.47	74	-18.23	185	164	Peak
Antenna Polarity & Test Distance: Vertical at 3 m								
Frequency (MHz)	Emission Level (dBuV/m)	Read Level (dBuV)	Factor (dB/m)	Limit (dBuV/m)	Margin (dB)	Antenna Height (cm)	Table Angle (Degree)	Remark
5745	103.94	93.06	10.88			208	267	Average
5745	110.29	99.41	10.88			208	267	Peak
11490	47.68	31.21	16.47	54	-6.32	164	121	Average
11490	57.38	40.91	16.47	74	-16.62	164	121	Peak

<Out of Band Emission (OOBE)>

Antenna Polarity & Test Distance: Horizontal at 3 m								
Frequency (MHz)	Emission Level (dBuV/m)	Read Level (dBuV)	Factor (dB/m)	Limit (dBuV/m)	Margin (dB)	Antenna Height (cm)	Table Angle (Degree)	Remark
*5638.075	52.42	41.59	10.83	68.2	-15.78	142	232	Peak
5662.225	53.7	42.83	10.87	77.25	-23.55	142	232	Peak
5921.575	50.82	39.71	11.11	70.73	-19.91	142	232	Peak
*5944.15	52.22	41.04	11.18	68.2	-15.98	142	232	Peak
Antenna Polarity & Test Distance: Vertical at 3 m								
Frequency (MHz)	Emission Level (dBuV/m)	Read Level (dBuV)	Factor (dB/m)	Limit (dBuV/m)	Margin (dB)	Antenna Height (cm)	Table Angle (Degree)	Remark
*5571.925	52.08	41.38	10.7	68.2	-16.12	208	267	Peak
5656.45	53.33	42.46	10.87	72.97	-19.64	208	267	Peak
5916.85	52.52	41.43	11.09	74.23	-21.71	208	267	Peak
*5941	52.75	41.57	11.18	68.2	-15.45	208	267	Peak

Remarks:

- Emission Level = Read Level + Factor
Margin value = Emission level – Limit value
- 5745 MHz: Fundamental Frequency
- *: Out of Restricted Band
- The emission levels of other frequencies were very low against the limit

EUT Test Condition		Measurement Detail	
Channel	Channel 157	Frequency Range	1 GHz ~ 40 GHz
Input Power	120 Vac, 60 Hz	Detector Function	Peak (PK) Average (AV)
Environmental Conditions	25 deg. C, 65 % RH	Tested By	Charles Hsiao

<Spurious Emission>

Antenna Polarity & Test Distance: Horizontal at 3 m								
Frequency (MHz)	Emission Level (dBuV/m)	Read Level (dBuV)	Factor (dB/m)	Limit (dBuV/m)	Margin (dB)	Antenna Height (cm)	Table Angle (Degree)	Remark
5785	100.33	89.52	10.81			142	232	Average
5785	107.43	96.62	10.81			142	232	Peak
11570	47.01	30.52	16.49	54	-6.99	116	235	Average
11570	56.55	40.06	16.49	74	-17.45	116	235	Peak
Antenna Polarity & Test Distance: Vertical at 3 m								
Frequency (MHz)	Emission Level (dBuV/m)	Read Level (dBuV)	Factor (dB/m)	Limit (dBuV/m)	Margin (dB)	Antenna Height (cm)	Table Angle (Degree)	Remark
5785	102.82	92.01	10.81			208	267	Average
5785	109.53	98.72	10.81			208	267	Peak
11570	46.85	30.36	16.49	54	-7.15	164	57	Average
11570	56.3	39.81	16.49	74	-17.7	164	57	Peak

<Out of Band Emission (OOBE)>

Antenna Polarity & Test Distance: Horizontal at 3 m								
Frequency (MHz)	Emission Level (dBuV/m)	Read Level (dBuV)	Factor (dB/m)	Limit (dBuV/m)	Margin (dB)	Antenna Height (cm)	Table Angle (Degree)	Remark
*5546.2	52.08	41.42	10.66	68.2	-16.12	142	232	Peak
5658.025	51.71	40.84	10.87	74.14	-22.43	142	232	Peak
5915.8	51.24	40.15	11.09	75.01	-23.77	142	232	Peak
*5929.975	52.36	41.25	11.11	68.2	-15.84	142	232	Peak
Antenna Polarity & Test Distance: Vertical at 3 m								
Frequency (MHz)	Emission Level (dBuV/m)	Read Level (dBuV)	Factor (dB/m)	Limit (dBuV/m)	Margin (dB)	Antenna Height (cm)	Table Angle (Degree)	Remark
*5649.625	52.65	41.78	10.87	68.2	-15.55	208	267	Peak
5659.075	51.43	40.56	10.87	74.92	-23.49	208	267	Peak
5915.275	51.18	40.09	11.09	75.4	-24.22	208	267	Peak
*6016.075	53.45	42.1	11.35	68.2	-14.75	208	267	Peak

Remarks:

- Emission Level = Read Level + Factor
Margin value = Emission level – Limit value
- 5785 MHz: Fundamental Frequency
- *: Out of Restricted Band
- The emission levels of other frequencies were very low against the limit

EUT Test Condition		Measurement Detail	
Channel	Channel 165	Frequency Range	1 GHz ~ 40 GHz
Input Power	120 Vac, 60 Hz	Detector Function	Peak (PK) Average (AV)
Environmental Conditions	25 deg. C, 65 % RH	Tested By	Charles Hsiao

<Spurious Emission>

Antenna Polarity & Test Distance: Horizontal at 3 m								
Frequency (MHz)	Emission Level (dBuV/m)	Read Level (dBuV)	Factor (dB/m)	Limit (dBuV/m)	Margin (dB)	Antenna Height (cm)	Table Angle (Degree)	Remark
5825	100.74	89.86	10.88			142	232	Average
5825	107.26	96.38	10.88			142	232	Peak
11650	46.82	30.04	16.78	54	-7.18	151	218	Average
11650	56.32	39.54	16.78	74	-17.68	151	218	Peak
Antenna Polarity & Test Distance: Vertical at 3 m								
Frequency (MHz)	Emission Level (dBuV/m)	Read Level (dBuV)	Factor (dB/m)	Limit (dBuV/m)	Margin (dB)	Antenna Height (cm)	Table Angle (Degree)	Remark
5825	102.44	91.56	10.88			208	267	Average
5825	109.85	98.97	10.88			208	267	Peak
11650	46.64	29.86	16.78	54	-7.36	184	296	Average
11650	56.36	39.58	16.78	74	-17.64	184	296	Peak

<Out of Band Emission (OOBE)>

Antenna Polarity & Test Distance: Horizontal at 3 m								
Frequency (MHz)	Emission Level (dBuV/m)	Read Level (dBuV)	Factor (dB/m)	Limit (dBuV/m)	Margin (dB)	Antenna Height (cm)	Table Angle (Degree)	Remark
*5602.9	52.13	41.38	10.75	68.2	-16.07	142	232	Peak
5660.125	51.11	40.24	10.87	75.69	-24.58	142	232	Peak
5917.375	50.81	39.72	11.09	73.84	-23.03	142	232	Peak
*5958.85	52.06	40.85	11.21	68.2	-16.14	142	232	Peak
Antenna Polarity & Test Distance: Vertical at 3 m								
Frequency (MHz)	Emission Level (dBuV/m)	Read Level (dBuV)	Factor (dB/m)	Limit (dBuV/m)	Margin (dB)	Antenna Height (cm)	Table Angle (Degree)	Remark
*5555.65	52.29	41.63	10.66	68.2	-15.91	208	267	Peak
5654.875	51.42	40.55	10.87	71.81	-20.39	208	267	Peak
5918.95	50.2	39.11	11.09	72.68	-22.48	208	267	Peak
*5996.65	52.76	41.43	11.33	68.2	-15.44	208	267	Peak

Remarks:

- Emission Level = Read Level + Factor
Margin value = Emission level – Limit value
- 5825 MHz: Fundamental Frequency
- *: Out of Restricted Band
- The emission levels of other frequencies were very low against the limit

802.11n (HT20)

EUT Test Condition		Measurement Detail	
Channel	Channel 36	Frequency Range	1 GHz ~ 40 GHz
Input Power	120 Vac, 60 Hz	Detector Function	Peak (PK) Average (AV)
Environmental Conditions	25 deg. C, 65 % RH	Tested By	Harry Hsueh

Antenna Polarity & Test Distance: Horizontal at 3 m								
Frequency (MHz)	Emission Level (dBuV/m)	Read Level (dBuV)	Factor (dB/m)	Limit (dBuV/m)	Margin (dB)	Antenna Height (cm)	Table Angle (Degree)	Remark
5148.95	44.21	34.16	10.05	54	-9.79	250	162	Average
5148.95	54.89	44.84	10.05	74	-19.11	250	162	Peak
5180	99.67	89.55	10.12			250	162	Average
5180	107.03	96.91	10.12			250	162	Peak
*10360	54.03	38.01	16.02	68.2	-14.17	196	235	Peak
Antenna Polarity & Test Distance: Vertical at 3 m								
Frequency (MHz)	Emission Level (dBuV/m)	Read Level (dBuV)	Factor (dB/m)	Limit (dBuV/m)	Margin (dB)	Antenna Height (cm)	Table Angle (Degree)	Remark
5149.4	44.36	34.31	10.05	54	-9.64	268	71	Average
5149.4	53.59	43.54	10.05	74	-20.41	268	71	Peak
5180	100.38	90.26	10.12			268	71	Average
5180	108.11	97.99	10.12			268	71	Peak
*10360	55.06	39.04	16.02	68.2	-13.14	172	131	Peak

Remarks:

- Emission Level = Read Level + Factor
Margin value = Emission level – Limit value
- 5180 MHz: Fundamental Frequency
- *: Out of Restricted Band
- The emission levels of other frequencies were very low against the limit

EUT Test Condition		Measurement Detail	
Channel	Channel 40	Frequency Range	1 GHz ~ 40 GHz
Input Power	120 Vac, 60 Hz	Detector Function	Peak (PK) Average (AV)
Environmental Conditions	25 deg. C, 65 % RH	Tested By	Harry Hsueh

Antenna Polarity & Test Distance: Horizontal at 3 m								
Frequency (MHz)	Emission Level (dBuV/m)	Read Level (dBuV)	Factor (dB/m)	Limit (dBuV/m)	Margin (dB)	Antenna Height (cm)	Table Angle (Degree)	Remark
5120.15	43.02	33.05	9.97	54	-10.98	249	354	Average
5120.15	52.46	42.49	9.97	74	-21.54	249	354	Peak
5200	101.41	91.25	10.16			249	354	Average
5200	108.94	98.78	10.16			249	354	Peak
5355.39	42.41	32.18	10.23	54	-11.59	249	354	Average
5355.39	52.9	42.67	10.23	74	-21.1	249	354	Peak
*10400	54.5	38.32	16.18	68.2	-13.7	169	151	Peak
Antenna Polarity & Test Distance: Vertical at 3 m								
Frequency (MHz)	Emission Level (dBuV/m)	Read Level (dBuV)	Factor (dB/m)	Limit (dBuV/m)	Margin (dB)	Antenna Height (cm)	Table Angle (Degree)	Remark
5150	44.15	34.1	10.05	54	-9.85	268	71	Average
5150	53.93	43.88	10.05	74	-20.07	268	71	Peak
5200	101.41	91.25	10.16			268	71	Average
5200	109.54	99.38	10.16			268	71	Peak
5354.73	42.24	32.01	10.23	54	-11.76	268	71	Average
5354.73	52.96	42.73	10.23	74	-21.04	268	71	Peak
*10400	54.46	38.28	16.18	68.2	-13.74	109	256	Peak

Remarks:

- Emission Level = Read Level + Factor
Margin value = Emission level – Limit value
- 5200 MHz: Fundamental Frequency
- *: Out of Restricted Band
- The emission levels of other frequencies were very low against the limit

EUT Test Condition		Measurement Detail	
Channel	Channel 48	Frequency Range	1 GHz ~ 40 GHz
Input Power	120 Vac, 60 Hz	Detector Function	Peak (PK) Average (AV)
Environmental Conditions	25 deg. C, 65 % RH	Tested By	Karl Lee

Antenna Polarity & Test Distance: Horizontal at 3 m								
Frequency (MHz)	Emission Level (dBuV/m)	Read Level (dBuV)	Factor (dB/m)	Limit (dBuV/m)	Margin (dB)	Antenna Height (cm)	Table Angle (Degree)	Remark
5240	101.29	91.15	10.14			254	354	Average
5240	107.69	97.55	10.14			254	354	Peak
5375.41	43.22	32.93	10.29	54	-10.78	254	354	Average
5375.41	52.9	42.61	10.29	74	-21.1	254	354	Peak
*10480	54.79	38.89	15.9	68.2	-13.41	136	111	Peak
Antenna Polarity & Test Distance: Vertical at 3 m								
Frequency (MHz)	Emission Level (dBuV/m)	Read Level (dBuV)	Factor (dB/m)	Limit (dBuV/m)	Margin (dB)	Antenna Height (cm)	Table Angle (Degree)	Remark
5240	102.48	92.34	10.14			268	71	Average
5240	108.75	98.61	10.14			268	71	Peak
5388.28	43.34	33	10.34	54	-10.66	268	71	Average
5388.28	52.9	42.56	10.34	74	-21.1	268	71	Peak
*10480	53.77	37.87	15.9	68.2	-14.43	156	84	Peak

Remarks:

- Emission Level = Read Level + Factor
Margin value = Emission level – Limit value
- 5240 MHz: Fundamental Frequency
- *: Out of Restricted Band
- The emission levels of other frequencies were very low against the limit

EUT Test Condition		Measurement Detail	
Channel	Channel 52	Frequency Range	1 GHz ~ 40 GHz
Input Power	120 Vac, 60 Hz	Detector Function	Peak (PK) Average (AV)
Environmental Conditions	25 deg. C, 65 % RH	Tested By	Karl Lee

Antenna Polarity & Test Distance: Horizontal at 3 m								
Frequency (MHz)	Emission Level (dBuV/m)	Read Level (dBuV)	Factor (dB/m)	Limit (dBuV/m)	Margin (dB)	Antenna Height (cm)	Table Angle (Degree)	Remark
5146.85	42.94	32.89	10.05	54	-11.06	241	355	Average
5146.85	52.62	42.57	10.05	74	-21.38	241	355	Peak
5260	103.68	93.56	10.12			241	355	Average
5260	108.42	98.3	10.12			241	355	Peak
*10520	54.65	38.77	15.88	68.2	-13.55	188	197	Peak

Antenna Polarity & Test Distance: Vertical at 3 m								
Frequency (MHz)	Emission Level (dBuV/m)	Read Level (dBuV)	Factor (dB/m)	Limit (dBuV/m)	Margin (dB)	Antenna Height (cm)	Table Angle (Degree)	Remark
5147.75	42.83	32.78	10.05	54	-11.17	200	271	Average
5147.75	53.6	43.55	10.05	74	-20.4	200	271	Peak
5260	105.84	95.72	10.12			200	271	Average
5260	110.85	100.73	10.12			200	271	Peak
*10520	54.03	38.15	15.88	68.2	-14.17	154	272	Peak

Remarks:

- Emission Level = Read Level + Factor
Margin value = Emission level – Limit value
- 5260 MHz: Fundamental Frequency
- *: Out of Restricted Band
- The emission levels of other frequencies were very low against the limit

EUT Test Condition		Measurement Detail	
Channel	Channel 60	Frequency Range	1 GHz ~ 40 GHz
Input Power	120 Vac, 60 Hz	Detector Function	Peak (PK) Average (AV)
Environmental Conditions	25 deg. C, 65 % RH	Tested By	Karl Lee

Antenna Polarity & Test Distance: Horizontal at 3 m								
Frequency (MHz)	Emission Level (dBuV/m)	Read Level (dBuV)	Factor (dB/m)	Limit (dBuV/m)	Margin (dB)	Antenna Height (cm)	Table Angle (Degree)	Remark
5120	44.11	34.14	9.97	54	-9.89	241	355	Average
5120	52.81	42.84	9.97	74	-21.19	241	355	Peak
5300	102.68	92.62	10.06			241	355	Average
5300	109.09	99.03	10.06			241	355	Peak
5350.88	44.05	33.82	10.23	54	-9.95	241	355	Average
5350.88	53.47	43.24	10.23	74	-20.53	241	355	Peak
10600	47.15	31.39	15.76	54	-6.85	172	22	Average
10600	52.19	36.43	15.76	74	-21.81	172	22	Peak

Antenna Polarity & Test Distance: Vertical at 3 m								
Frequency (MHz)	Emission Level (dBuV/m)	Read Level (dBuV)	Factor (dB/m)	Limit (dBuV/m)	Margin (dB)	Antenna Height (cm)	Table Angle (Degree)	Remark
5145.95	43.99	33.94	10.05	54	-10.01	200	271	Average
5145.95	52.54	42.49	10.05	74	-21.46	200	271	Peak
5300	104.2	94.14	10.06			200	271	Average
5300	110.92	100.86	10.06			200	271	Peak
5351.21	44.85	34.62	10.23	54	-9.15	200	271	Average
5351.21	53.55	43.32	10.23	74	-20.45	200	271	Peak
10600	47.1	31.34	15.76	54	-6.9	175	105	Average
10600	54.71	38.95	15.76	74	-19.29	175	105	Peak

Remarks:

- Emission Level = Read Level + Factor
Margin value = Emission level – Limit value
- 5300 MHz: Fundamental Frequency
- *: Out of Restricted Band
- The emission levels of other frequencies were very low against the limit

EUT Test Condition		Measurement Detail	
Channel	Channel 64	Frequency Range	1 GHz ~ 40 GHz
Input Power	120 Vac, 60 Hz	Detector Function	Peak (PK) Average (AV)
Environmental Conditions	25 deg. C, 65 % RH	Tested By	Karl Lee

Antenna Polarity & Test Distance: Horizontal at 3 m								
Frequency (MHz)	Emission Level (dBuV/m)	Read Level (dBuV)	Factor (dB/m)	Limit (dBuV/m)	Margin (dB)	Antenna Height (cm)	Table Angle (Degree)	Remark
5320	99.65	89.56	10.09			241	355	Average
5320	106.63	96.54	10.09			241	355	Peak
5350	46.49	36.26	10.23	54	-7.51	241	355	Average
5350	54.14	43.91	10.23	74	-19.86	241	355	Peak
10640	47.43	31.44	15.99	54	-6.57	197	310	Average
10640	53.69	37.7	15.99	74	-20.31	197	310	Peak
Antenna Polarity & Test Distance: Vertical at 3 m								
Frequency (MHz)	Emission Level (dBuV/m)	Read Level (dBuV)	Factor (dB/m)	Limit (dBuV/m)	Margin (dB)	Antenna Height (cm)	Table Angle (Degree)	Remark
5320	101.83	91.74	10.09			200	271	Average
5320	108.24	98.15	10.09			200	271	Peak
5350	47.64	37.41	10.23	54	-6.36	200	271	Average
5350	56.02	45.79	10.23	74	-17.98	200	271	Peak
10640	47.41	31.42	15.99	54	-6.59	108	188	Average
10640	54.1	38.11	15.99	74	-19.9	108	188	Peak

Remarks:

- Emission Level = Read Level + Factor
Margin value = Emission level – Limit value
- 5320 MHz: Fundamental Frequency
- *: Out of Restricted Band
- The emission levels of other frequencies were very low against the limit

EUT Test Condition		Measurement Detail	
Channel	Channel 100	Frequency Range	1 GHz ~ 40 GHz
Input Power	120 Vac, 60 Hz	Detector Function	Peak (PK) Average (AV)
Environmental Conditions	25 deg. C, 65 % RH	Tested By	Charles Hsiao

Antenna Polarity & Test Distance: Horizontal at 3 m								
Frequency (MHz)	Emission Level (dBuV/m)	Read Level (dBuV)	Factor (dB/m)	Limit (dBuV/m)	Margin (dB)	Antenna Height (cm)	Table Angle (Degree)	Remark
5459.92	42.33	31.82	10.51	54	-11.67	204	145	Average
5459.92	53.02	42.51	10.51	74	-20.98	204	145	Peak
*5469.04	51.8	41.27	10.53	68.2	-16.4	204	145	Peak
5500	98.57	87.97	10.6			204	145	Average
5500	105.04	94.44	10.6			204	145	Peak
11000	43.87	27.74	16.13	54	-10.13	196	218	Average
11000	53.52	37.39	16.13	74	-20.48	196	218	Peak
Antenna Polarity & Test Distance: Vertical at 3 m								
Frequency (MHz)	Emission Level (dBuV/m)	Read Level (dBuV)	Factor (dB/m)	Limit (dBuV/m)	Margin (dB)	Antenna Height (cm)	Table Angle (Degree)	Remark
5459.92	43.71	33.2	10.51	54	-10.29	174	273	Average
5459.92	53.47	42.96	10.51	74	-20.53	174	273	Peak
*5470	53.93	43.4	10.53	68.2	-14.27	174	273	Peak
5500	100.37	89.77	10.6			174	273	Average
5500	107.35	96.75	10.6			174	273	Peak
11000	43.94	27.81	16.13	54	-10.06	174	135	Average
11000	53.58	37.45	16.13	74	-20.42	174	135	Peak

Remarks:

- Emission Level = Read Level + Factor
Margin value = Emission level – Limit value
- 5500 MHz: Fundamental Frequency
- *: Out of Restricted Band
- The emission levels of other frequencies were very low against the limit

EUT Test Condition		Measurement Detail	
Channel	Channel 116	Frequency Range	1 GHz ~ 40 GHz
Input Power	120 Vac, 60 Hz	Detector Function	Peak (PK) Average (AV)
Environmental Conditions	25 deg. C, 65 % RH	Tested By	Charles Hsiao

Antenna Polarity & Test Distance: Horizontal at 3 m								
Frequency (MHz)	Emission Level (dBuV/m)	Read Level (dBuV)	Factor (dB/m)	Limit (dBuV/m)	Margin (dB)	Antenna Height (cm)	Table Angle (Degree)	Remark
5445.36	41.9	31.42	10.48	54	-12.1	204	145	Average
5445.36	52.39	41.91	10.48	74	-21.61	204	145	Peak
*5470	50.94	40.41	10.53	68.2	-17.26	204	145	Peak
5580	98.39	87.68	10.71			204	145	Average
5580	105.4	94.69	10.71			204	145	Peak
*5725	51.56	40.64	10.92	68.2	-16.64	204	145	Peak
11160	46.23	29.87	16.36	54	-7.77	103	218	Average
11160	55.86	39.5	16.36	74	-18.14	103	218	Peak

Antenna Polarity & Test Distance: Vertical at 3 m								
Frequency (MHz)	Emission Level (dBuV/m)	Read Level (dBuV)	Factor (dB/m)	Limit (dBuV/m)	Margin (dB)	Antenna Height (cm)	Table Angle (Degree)	Remark
5456.24	42.06	31.55	10.51	54	-11.94	174	273	Average
5456.24	52.25	41.74	10.51	74	-21.75	174	273	Peak
*5470	50.86	40.33	10.53	68.2	-17.34	174	273	Peak
5580	100.37	89.66	10.71			174	273	Average
5580	107.12	96.41	10.71			174	273	Peak
*5725.24	51.1	40.18	10.92	68.2	-17.1	174	273	Peak
11160	46.47	30.11	16.36	54	-7.53	151	334	Average
11160	55.95	39.59	16.36	74	-18.05	151	334	Peak

Remarks:

- Emission Level = Read Level + Factor
Margin value = Emission level – Limit value
- 5580 MHz: Fundamental Frequency
- *: Out of Restricted Band
- The emission levels of other frequencies were very low against the limit

EUT Test Condition		Measurement Detail	
Channel	Channel 140	Frequency Range	1 GHz ~ 40 GHz
Input Power	120 Vac, 60 Hz	Detector Function	Peak (PK) Average (AV)
Environmental Conditions	25 deg. C, 65 % RH	Tested By	Charles Hsiao

Antenna Polarity & Test Distance: Horizontal at 3 m								
Frequency (MHz)	Emission Level (dBuV/m)	Read Level (dBuV)	Factor (dB/m)	Limit (dBuV/m)	Margin (dB)	Antenna Height (cm)	Table Angle (Degree)	Remark
5700	100.37	89.42	10.95			204	145	Average
5700	107.77	96.82	10.95			204	145	Peak
*5725	60.93	50.01	10.92	68.2	-7.27	204	145	Peak
11400	46.13	29.94	16.19	54	-7.87	108	29	Average
11400	55.89	39.7	16.19	74	-18.11	108	29	Peak
Antenna Polarity & Test Distance: Vertical at 3 m								
Frequency (MHz)	Emission Level (dBuV/m)	Read Level (dBuV)	Factor (dB/m)	Limit (dBuV/m)	Margin (dB)	Antenna Height (cm)	Table Angle (Degree)	Remark
5700	102.25	91.3	10.95			174	273	Average
5700	109.33	98.38	10.95			174	273	Peak
*5725.08	63.44	52.52	10.92	68.2	-4.76	174	273	Peak
11400	45.74	29.55	16.19	54	-8.26	182	154	Average
11400	55.3	39.11	16.19	74	-18.7	182	154	Peak

Remarks:

- Emission Level = Read Level + Factor
Margin value = Emission level – Limit value
- 5700 MHz: Fundamental Frequency
- *: Out of Restricted Band
- The emission levels of other frequencies were very low against the limit

EUT Test Condition		Measurement Detail	
Channel	Channel 144	Frequency Range	1 GHz ~ 40 GHz
Input Power	120 Vac, 60 Hz	Detector Function	Peak (PK) Average (AV)
Environmental Conditions	25 deg. C, 65 % RH	Tested By	Charles Hsiao

Antenna Polarity & Test Distance: Horizontal at 3 m								
Frequency (MHz)	Emission Level (dBuV/m)	Read Level (dBuV)	Factor (dB/m)	Limit (dBuV/m)	Margin (dB)	Antenna Height (cm)	Table Angle (Degree)	Remark
5448.88	41.98	31.49	10.49	54	-12.02	204	145	Average
5448.88	52.58	42.09	10.49	74	-21.42	204	145	Peak
*5469.84	50.69	40.16	10.53	68.2	-17.51	204	145	Peak
5720	100.44	89.52	10.92			204	145	Average
5720	107.08	96.16	10.92			204	145	Peak
11440	45.86	29.57	16.29	54	-8.14	189	236	Average
11440	55.49	39.2	16.29	74	-18.51	189	236	Peak
Antenna Polarity & Test Distance: Vertical at 3 m								
Frequency (MHz)	Emission Level (dBuV/m)	Read Level (dBuV)	Factor (dB/m)	Limit (dBuV/m)	Margin (dB)	Antenna Height (cm)	Table Angle (Degree)	Remark
5456.24	42.34	31.83	10.51	54	-11.66	174	273	Average
5456.24	53.81	43.3	10.51	74	-20.19	174	273	Peak
*5469.36	51.52	40.99	10.53	68.2	-16.68	174	273	Peak
5720	102.36	91.44	10.92			174	273	Average
5720	109.42	98.5	10.92			174	273	Peak
11440	44.86	28.57	16.29	54	-9.14	187	194	Average
11440	54.44	38.15	16.29	74	-19.56	187	194	Peak

Remarks:

- Emission Level = Read Level + Factor
Margin value = Emission level – Limit value
- 5720 MHz: Fundamental Frequency
- *: Out of Restricted Band
- The emission levels of other frequencies were very low against the limit

EUT Test Condition		Measurement Detail	
Channel	Channel 149	Frequency Range	1 GHz ~ 40 GHz
Input Power	120 Vac, 60 Hz	Detector Function	Peak (PK) Average (AV)
Environmental Conditions	25 deg. C, 65 % RH	Tested By	Charles Hsiao

<Spurious Emission>

Antenna Polarity & Test Distance: Horizontal at 3 m								
Frequency (MHz)	Emission Level (dBuV/m)	Read Level (dBuV)	Factor (dB/m)	Limit (dBuV/m)	Margin (dB)	Antenna Height (cm)	Table Angle (Degree)	Remark
5745	103.25	92.37	10.88			204	145	Average
5745	110.45	99.57	10.88			204	145	Peak
11490	47.96	31.49	16.47	54	-6.04	154	296	Average
11490	56.29	39.82	16.47	74	-17.71	154	296	Peak

Antenna Polarity & Test Distance: Vertical at 3 m								
Frequency (MHz)	Emission Level (dBuV/m)	Read Level (dBuV)	Factor (dB/m)	Limit (dBuV/m)	Margin (dB)	Antenna Height (cm)	Table Angle (Degree)	Remark
5745	104.47	93.59	10.88			174	273	Average
5745	111.66	100.78	10.88			174	273	Peak
11490	47.82	31.35	16.47	54	-6.18	144	144	Average
11490	56.41	39.94	16.47	74	-17.59	144	144	Peak

<Out of Band Emission (OOBE)>

Antenna Polarity & Test Distance: Horizontal at 3 m								
Frequency (MHz)	Emission Level (dBuV/m)	Read Level (dBuV)	Factor (dB/m)	Limit (dBuV/m)	Margin (dB)	Antenna Height (cm)	Table Angle (Degree)	Remark
*5593.975	52.88	42.13	10.75	68.2	-15.32	204	145	Peak
5655.4	51.65	40.78	10.87	72.2	-20.55	204	145	Peak
5918.425	50.95	39.86	11.09	73.07	-22.12	204	145	Peak
*6000.325	52.27	40.94	11.33	68.2	-15.93	204	145	Peak

Antenna Polarity & Test Distance: Vertical at 3 m								
Frequency (MHz)	Emission Level (dBuV/m)	Read Level (dBuV)	Factor (dB/m)	Limit (dBuV/m)	Margin (dB)	Antenna Height (cm)	Table Angle (Degree)	Remark
*5547.25	53.61	42.95	10.66	68.2	-14.59	174	273	Peak
5653.825	52.89	42.02	10.87	71.03	-18.14	174	273	Peak
5921.05	51.04	39.95	11.09	71.12	-20.08	174	273	Peak
*5988.775	52.1	40.79	11.31	68.2	-16.1	174	273	Peak

Remarks:

- Emission Level = Read Level + Factor
Margin value = Emission level – Limit value
- 5745 MHz: Fundamental Frequency
- *: Out of Restricted Band
- The emission levels of other frequencies were very low against the limit

EUT Test Condition		Measurement Detail	
Channel	Channel 157	Frequency Range	1 GHz ~ 40 GHz
Input Power	120 Vac, 60 Hz	Detector Function	Peak (PK) Average (AV)
Environmental Conditions	25 deg. C, 65 % RH	Tested By	Charles Hsiao

<Spurious Emission>

Antenna Polarity & Test Distance: Horizontal at 3 m								
Frequency (MHz)	Emission Level (dBuV/m)	Read Level (dBuV)	Factor (dB/m)	Limit (dBuV/m)	Margin (dB)	Antenna Height (cm)	Table Angle (Degree)	Remark
5785	102.25	91.44	10.81			204	145	Average
5785	109.31	98.5	10.81			204	145	Peak
11570	48.03	31.54	16.49	54	-5.97	118	17	Average
11570	56.12	39.63	16.49	74	-17.88	118	17	Peak
Antenna Polarity & Test Distance: Vertical at 3 m								
Frequency (MHz)	Emission Level (dBuV/m)	Read Level (dBuV)	Factor (dB/m)	Limit (dBuV/m)	Margin (dB)	Antenna Height (cm)	Table Angle (Degree)	Remark
5785	103.64	92.83	10.81			174	273	Average
5785	110.34	99.53	10.81			174	273	Peak
11570	48.34	31.85	16.49	54	-5.66	114	152	Average
11570	56.61	40.12	16.49	74	-17.39	114	152	Peak

<Out of Band Emission (OOBE)>

Antenna Polarity & Test Distance: Horizontal at 3 m								
Frequency (MHz)	Emission Level (dBuV/m)	Read Level (dBuV)	Factor (dB/m)	Limit (dBuV/m)	Margin (dB)	Antenna Height (cm)	Table Angle (Degree)	Remark
*5597.125	52.41	41.66	10.75	68.2	-15.79	204	145	Peak
5656.45	51.87	41	10.87	72.97	-21.1	204	145	Peak
5922.1	50.74	39.63	11.11	70.35	-19.61	204	145	Peak
*5945.725	52.8	41.62	11.18	68.2	-15.4	204	145	Peak
Antenna Polarity & Test Distance: Vertical at 3 m								
Frequency (MHz)	Emission Level (dBuV/m)	Read Level (dBuV)	Factor (dB/m)	Limit (dBuV/m)	Margin (dB)	Antenna Height (cm)	Table Angle (Degree)	Remark
*5613.925	53.62	42.85	10.77	68.2	-14.58	174	273	Peak
5654.35	52.32	41.45	10.87	71.42	-19.1	174	273	Peak
5918.95	50.96	39.87	11.09	72.68	-21.72	174	273	Peak
*5979.85	52.79	41.53	11.26	68.2	-15.41	174	273	Peak

Remarks:

- Emission Level = Read Level + Factor
Margin value = Emission level – Limit value
- 5785 MHz: Fundamental Frequency
- *: Out of Restricted Band
- The emission levels of other frequencies were very low against the limit

EUT Test Condition		Measurement Detail	
Channel	Channel 165	Frequency Range	1 GHz ~ 40 GHz
Input Power	120 Vac, 60 Hz	Detector Function	Peak (PK) Average (AV)
Environmental Conditions	25 deg. C, 65 % RH	Tested By	Charles Hsiao

<Spurious Emission>

Antenna Polarity & Test Distance: Horizontal at 3 m								
Frequency (MHz)	Emission Level (dBuV/m)	Read Level (dBuV)	Factor (dB/m)	Limit (dBuV/m)	Margin (dB)	Antenna Height (cm)	Table Angle (Degree)	Remark
5825	103.36	92.48	10.88			204	145	Average
5825	110.37	99.49	10.88			204	145	Peak
11650	48.22	31.44	16.78	54	-5.78	165	266	Average
11650	55.45	38.67	16.78	74	-18.55	165	266	Peak
Antenna Polarity & Test Distance: Vertical at 3 m								
Frequency (MHz)	Emission Level (dBuV/m)	Read Level (dBuV)	Factor (dB/m)	Limit (dBuV/m)	Margin (dB)	Antenna Height (cm)	Table Angle (Degree)	Remark
5825	104.44	93.56	10.88			174	273	Average
5825	111.56	100.68	10.88			174	273	Peak
11650	48.56	31.78	16.78	54	-5.44	118	25	Average
11650	56.32	39.54	16.78	74	-17.68	118	25	Peak

<Out of Band Emission (OOBE)>

Antenna Polarity & Test Distance: Horizontal at 3 m								
Frequency (MHz)	Emission Level (dBuV/m)	Read Level (dBuV)	Factor (dB/m)	Limit (dBuV/m)	Margin (dB)	Antenna Height (cm)	Table Angle (Degree)	Remark
*5606.575	53.14	42.39	10.75	68.2	-15.06	204	145	Peak
5659.6	51.96	41.09	10.87	75.3	-23.34	204	145	Peak
5919.475	52.14	41.05	11.09	72.29	-20.15	204	145	Peak
*5970.925	52.38	41.13	11.25	68.2	-15.82	204	145	Peak
Antenna Polarity & Test Distance: Vertical at 3 m								
Frequency (MHz)	Emission Level (dBuV/m)	Read Level (dBuV)	Factor (dB/m)	Limit (dBuV/m)	Margin (dB)	Antenna Height (cm)	Table Angle (Degree)	Remark
*5634.4	53.22	42.39	10.83	68.2	-14.98	174	273	Peak
5654.875	53.2	42.33	10.87	71.81	-18.61	174	273	Peak
5918.95	51.42	40.33	11.09	72.68	-21.26	174	273	Peak
*6004	53.17	41.84	11.33	68.2	-15.03	174	273	Peak

Remarks:

- Emission Level = Read Level + Factor
Margin value = Emission level – Limit value
- 5825 MHz: Fundamental Frequency
- *: Out of Restricted Band
- The emission levels of other frequencies were very low against the limit

802.11n (HT40)

EUT Test Condition		Measurement Detail	
Channel	Channel 38	Frequency Range	1 GHz ~ 40 GHz
Input Power	120 Vac, 60 Hz	Detector Function	Peak (PK) Average (AV)
Environmental Conditions	25 deg. C, 65 % RH	Tested By	Karl Lee

Antenna Polarity & Test Distance: Horizontal at 3 m

Frequency (MHz)	Emission Level (dBuV/m)	Read Level (dBuV)	Factor (dB/m)	Limit (dBuV/m)	Margin (dB)	Antenna Height (cm)	Table Angle (Degree)	Remark
5148.05	51.01	40.96	10.05	54	-2.99	254	356	Average
5148.05	57.53	47.48	10.05	74	-16.47	254	356	Peak
5190	98.29	88.17	10.12			254	356	Average
5190	105.54	95.42	10.12			254	356	Peak
5417.1	43.11	32.69	10.42	54	-10.89	254	356	Average
5417.1	52.87	42.45	10.42	74	-21.13	254	356	Peak
*10380	54.73	38.63	16.1	68.2	-13.47	174	113	Peak

Antenna Polarity & Test Distance: Vertical at 3 m

Frequency (MHz)	Emission Level (dBuV/m)	Read Level (dBuV)	Factor (dB/m)	Limit (dBuV/m)	Margin (dB)	Antenna Height (cm)	Table Angle (Degree)	Remark
5150	52.86	42.81	10.05	54	-1.14	268	71	Average
5150	60.05	50	10.05	74	-13.95	268	71	Peak
5190	98.82	88.7	10.12			268	71	Average
5190	106.6	96.48	10.12			268	71	Peak
5422.05	43.27	32.85	10.42	54	-10.73	268	71	Average
5422.05	52.43	42.01	10.42	74	-21.57	268	71	Peak
*10380	55.53	39.43	16.1	68.2	-12.67	195	206	Peak

Remarks:

- Emission Level = Read Level + Factor
Margin value = Emission level – Limit value
- 5190 MHz: Fundamental Frequency
- *: Out of Restricted Band
- The emission levels of other frequencies were very low against the limit

EUT Test Condition		Measurement Detail	
Channel	Channel 46	Frequency Range	1 GHz ~ 40 GHz
Input Power	120 Vac, 60 Hz	Detector Function	Peak (PK) Average (AV)
Environmental Conditions	25 deg. C, 65 % RH	Tested By	Karl Lee

Antenna Polarity & Test Distance: Horizontal at 3 m								
Frequency (MHz)	Emission Level (dBuV/m)	Read Level (dBuV)	Factor (dB/m)	Limit (dBuV/m)	Margin (dB)	Antenna Height (cm)	Table Angle (Degree)	Remark
5132.3	43.57	33.57	10	54	-10.43	254	354	Average
5132.3	53.83	43.83	10	74	-20.17	254	354	Peak
5230	97.9	87.76	10.14			254	354	Average
5230	105.11	94.97	10.14			254	354	Peak
5350.11	43.59	33.36	10.23	54	-10.41	254	354	Average
5350.11	53.04	42.81	10.23	74	-20.96	254	354	Peak
*10460	54.08	38.08	16	68.2	-14.12	158	124	Peak

Antenna Polarity & Test Distance: Vertical at 3 m								
Frequency (MHz)	Emission Level (dBuV/m)	Read Level (dBuV)	Factor (dB/m)	Limit (dBuV/m)	Margin (dB)	Antenna Height (cm)	Table Angle (Degree)	Remark
5146.4	44.98	34.93	10.05	54	-9.02	268	71	Average
5146.4	54.29	44.24	10.05	74	-19.71	268	71	Peak
5230	99.47	89.33	10.14			268	71	Average
5230	106.45	96.31	10.14			268	71	Peak
5356.27	43.82	33.59	10.23	54	-10.18	268	71	Average
5356.27	54.3	44.07	10.23	74	-19.7	268	71	Peak
*10460	54.64	38.64	16	68.2	-13.56	184	316	Peak

Remarks:

- Emission Level = Read Level + Factor
Margin value = Emission level – Limit value
- 5230 MHz: Fundamental Frequency
- *: Out of Restricted Band
- The emission levels of other frequencies were very low against the limit

EUT Test Condition		Measurement Detail	
Channel	Channel 54	Frequency Range	1 GHz ~ 40 GHz
Input Power	120 Vac, 60 Hz	Detector Function	Peak (PK) Average (AV)
Environmental Conditions	25 deg. C, 65 % RH	Tested By	Karl Lee

Antenna Polarity & Test Distance: Horizontal at 3 m								
Frequency (MHz)	Emission Level (dBuV/m)	Read Level (dBuV)	Factor (dB/m)	Limit (dBuV/m)	Margin (dB)	Antenna Height (cm)	Table Angle (Degree)	Remark
5120	44.22	34.25	9.97	54	-9.78	241	355	Average
5120	52.77	42.8	9.97	74	-21.23	241	355	Peak
5270	100.39	90.27	10.12			241	355	Average
5270	106.72	96.6	10.12			241	355	Peak
5350.66	46.91	36.68	10.23	54	-7.09	241	355	Average
5350.66	54.09	43.86	10.23	74	-19.91	241	355	Peak
*10540	54.1	38.27	15.83	68.2	-14.1	110	24	Peak
Antenna Polarity & Test Distance: Vertical at 3 m								
Frequency (MHz)	Emission Level (dBuV/m)	Read Level (dBuV)	Factor (dB/m)	Limit (dBuV/m)	Margin (dB)	Antenna Height (cm)	Table Angle (Degree)	Remark
5149.4	42.89	32.84	10.05	54	-11.11	200	271	Average
5149.4	53.75	43.7	10.05	74	-20.25	200	271	Peak
5270	101.55	91.43	10.12			200	271	Average
5270	109.37	99.25	10.12			200	271	Peak
5350.66	48.28	38.05	10.23	54	-5.72	200	271	Average
5350.66	55.65	45.42	10.23	74	-18.35	200	271	Peak
*10540	53.66	37.83	15.83	68.2	-14.54	127	227	Peak

Remarks:

- Emission Level = Read Level + Factor
Margin value = Emission level – Limit value
- 5270 MHz: Fundamental Frequency
- *: Out of Restricted Band
- The emission levels of other frequencies were very low against the limit

EUT Test Condition		Measurement Detail	
Channel	Channel 62	Frequency Range	1 GHz ~ 40 GHz
Input Power	120 Vac, 60 Hz	Detector Function	Peak (PK) Average (AV)
Environmental Conditions	25 deg. C, 65 % RH	Tested By	Charles Hsiao

Antenna Polarity & Test Distance: Horizontal at 3 m								
Frequency (MHz)	Emission Level (dBuV/m)	Read Level (dBuV)	Factor (dB/m)	Limit (dBuV/m)	Margin (dB)	Antenna Height (cm)	Table Angle (Degree)	Remark
5125.85	42.9	32.9	10	54	-11.1	241	355	Average
5125.85	52.66	42.66	10	74	-21.34	241	355	Peak
5310	96.85	86.76	10.09			241	355	Average
5310	103.38	93.29	10.09			241	355	Peak
5350.55	46.79	36.56	10.23	54	-7.21	241	355	Average
5350.55	56.69	46.46	10.23	74	-17.31	241	355	Peak
10620	47.99	32.11	15.88	54	-6.01	119	326	Average
10620	54.02	38.14	15.88	74	-19.98	119	326	Peak

Antenna Polarity & Test Distance: Vertical at 3 m								
Frequency (MHz)	Emission Level (dBuV/m)	Read Level (dBuV)	Factor (dB/m)	Limit (dBuV/m)	Margin (dB)	Antenna Height (cm)	Table Angle (Degree)	Remark
5129	41.68	31.68	10	54	-12.32	200	271	Average
5129	52.43	42.43	10	74	-21.57	200	271	Peak
5310	98.68	88.59	10.09			200	271	Average
5310	105.96	95.87	10.09			200	271	Peak
5350.88	48.34	38.11	10.23	54	-5.66	200	271	Average
5350.88	56.52	46.29	10.23	74	-17.48	200	271	Peak
10620	48.42	32.54	15.88	54	-5.58	119	345	Average
10620	54.22	38.34	15.88	74	-19.78	119	345	Peak

Remarks:

- Emission Level = Read Level + Factor
Margin value = Emission level – Limit value
- 5310 MHz: Fundamental Frequency
- *: Out of Restricted Band
- The emission levels of other frequencies were very low against the limit

EUT Test Condition		Measurement Detail	
Channel	Channel 102	Frequency Range	1 GHz ~ 40 GHz
Input Power	120 Vac, 60 Hz	Detector Function	Peak (PK) Average (AV)
Environmental Conditions	25 deg. C, 65 % RH	Tested By	Charles Hsiao

Antenna Polarity & Test Distance: Horizontal at 3 m								
Frequency (MHz)	Emission Level (dBuV/m)	Read Level (dBuV)	Factor (dB/m)	Limit (dBuV/m)	Margin (dB)	Antenna Height (cm)	Table Angle (Degree)	Remark
5459.28	42.91	32.4	10.51	54	-11.09	204	145	Average
5459.28	53.16	42.65	10.51	74	-20.84	204	145	Peak
*5469.68	54.63	44.1	10.53	68.2	-13.57	204	145	Peak
5510	94.64	84.04	10.6			204	145	Average
5510	101.67	91.07	10.6			204	145	Peak
*5725.72	51.49	40.57	10.92	68.2	-16.71	204	145	Peak
11020	44.37	28.21	16.16	54	-9.63	177	49	Average
11020	53.62	37.46	16.16	74	-20.38	177	49	Peak

Antenna Polarity & Test Distance: Vertical at 3 m								
Frequency (MHz)	Emission Level (dBuV/m)	Read Level (dBuV)	Factor (dB/m)	Limit (dBuV/m)	Margin (dB)	Antenna Height (cm)	Table Angle (Degree)	Remark
5459.92	44.19	33.68	10.51	54	-9.81	174	273	Average
5459.92	53.66	43.15	10.51	74	-20.34	174	273	Peak
*5470	57.36	46.83	10.53	68.2	-10.84	174	273	Peak
5510	96.47	85.87	10.6			174	273	Average
5510	103.74	93.14	10.6			174	273	Peak
*5725.08	51.16	40.24	10.92	68.2	-17.04	174	273	Peak
11020	43.65	27.49	16.16	54	-10.35	182	104	Average
11020	53.39	37.23	16.16	74	-20.61	182	104	Peak

Remarks:

- Emission Level = Read Level + Factor
Margin value = Emission level – Limit value
- 5510 MHz: Fundamental Frequency
- *: Out of Restricted Band
- The emission levels of other frequencies were very low against the limit

EUT Test Condition		Measurement Detail	
Channel	Channel 110	Frequency Range	1 GHz ~ 40 GHz
Input Power	120 Vac, 60 Hz	Detector Function	Peak (PK) Average (AV)
Environmental Conditions	25 deg. C, 65 % RH	Tested By	Charles Hsiao

Antenna Polarity & Test Distance: Horizontal at 3 m								
Frequency (MHz)	Emission Level (dBuV/m)	Read Level (dBuV)	Factor (dB/m)	Limit (dBuV/m)	Margin (dB)	Antenna Height (cm)	Table Angle (Degree)	Remark
5404.88	42.51	32.11	10.4	54	-11.49	204	145	Average
5404.88	52.47	42.07	10.4	74	-21.53	204	145	Peak
*5469.2	50.7	40.17	10.53	68.2	-17.5	204	145	Peak
5550	94.74	84.06	10.68			204	145	Average
5550	101.89	91.21	10.68			204	145	Peak
*5725	52.19	41.27	10.92	68.2	-16.01	204	145	Peak
11100	44.87	28.6	16.27	54	-9.13	195	268	Average
11100	53.45	37.18	16.27	74	-20.55	195	268	Peak

Antenna Polarity & Test Distance: Vertical at 3 m								
Frequency (MHz)	Emission Level (dBuV/m)	Read Level (dBuV)	Factor (dB/m)	Limit (dBuV/m)	Margin (dB)	Antenna Height (cm)	Table Angle (Degree)	Remark
5446.96	42.48	31.99	10.49	54	-11.52	174	273	Average
5446.96	52.83	42.34	10.49	74	-21.17	174	273	Peak
*5470	52.17	41.64	10.53	68.2	-16.03	174	273	Peak
5550	96.74	86.06	10.68			174	273	Average
5550	103.44	92.76	10.68			174	273	Peak
*5725.48	51.33	40.41	10.92	68.2	-16.87	174	273	Peak
11100	43.68	27.41	16.27	54	-10.32	172	165	Average
11100	53.16	36.89	16.27	74	-20.84	172	165	Peak

Remarks:

- Emission Level = Read Level + Factor
Margin value = Emission level – Limit value
- 5550 MHz: Fundamental Frequency
- *: Out of Restricted Band
- The emission levels of other frequencies were very low against the limit

EUT Test Condition		Measurement Detail	
Channel	Channel 134	Frequency Range	1 GHz ~ 40 GHz
Input Power	120 Vac, 60 Hz	Detector Function	Peak (PK) Average (AV)
Environmental Conditions	25 deg. C, 65 % RH	Tested By	Charles Hsiao

Antenna Polarity & Test Distance: Horizontal at 3 m								
Frequency (MHz)	Emission Level (dBuV/m)	Read Level (dBuV)	Factor (dB/m)	Limit (dBuV/m)	Margin (dB)	Antenna Height (cm)	Table Angle (Degree)	Remark
5431.28	42.61	32.13	10.48	54	-11.39	204	145	Average
5431.28	53.33	42.85	10.48	74	-20.67	204	145	Peak
*5469.68	51.82	41.29	10.53	68.2	-16.38	204	145	Peak
5670	98.57	87.67	10.9			204	145	Average
5670	105.25	94.35	10.9			204	145	Peak
*5725.72	57.89	46.97	10.92	68.2	-10.31	204	145	Peak
11340	46.72	30.3	16.42	54	-7.28	159	167	Average
11340	56.13	39.71	16.42	74	-17.87	159	167	Peak
Antenna Polarity & Test Distance: Vertical at 3 m								
Frequency (MHz)	Emission Level (dBuV/m)	Read Level (dBuV)	Factor (dB/m)	Limit (dBuV/m)	Margin (dB)	Antenna Height (cm)	Table Angle (Degree)	Remark
5448.08	42.92	32.43	10.49	54	-11.08	174	273	Average
5448.08	52.65	42.16	10.49	74	-21.35	174	273	Peak
*5469.84	51.78	41.25	10.53	68.2	-16.42	174	273	Peak
5670	101.28	90.38	10.9			174	273	Average
5670	108.42	97.52	10.9			174	273	Peak
*5725.08	60.27	49.35	10.92	68.2	-7.93	174	273	Peak
11340	45.29	28.87	16.42	54	-8.71	168	153	Average
11340	55	38.58	16.42	74	-19	168	153	Peak

Remarks:

- Emission Level = Read Level + Factor
Margin value = Emission level – Limit value
- 5670 MHz: Fundamental Frequency
- *: Out of Restricted Band
- The emission levels of other frequencies were very low against the limit

EUT Test Condition		Measurement Detail	
Channel	Channel 142	Frequency Range	1 GHz ~ 40 GHz
Input Power	120 Vac, 60 Hz	Detector Function	Peak (PK) Average (AV)
Environmental Conditions	25 deg. C, 65 % RH	Tested By	Charles Hsiao

Antenna Polarity & Test Distance: Horizontal at 3 m								
Frequency (MHz)	Emission Level (dBuV/m)	Read Level (dBuV)	Factor (dB/m)	Limit (dBuV/m)	Margin (dB)	Antenna Height (cm)	Table Angle (Degree)	Remark
5458.16	42.06	31.55	10.51	54	-11.94	204	145	Average
5458.16	52.33	41.82	10.51	74	-21.67	204	145	Peak
*5469.52	50.44	39.91	10.53	68.2	-17.76	204	145	Peak
5710	98.59	87.68	10.91			204	145	Average
5710	105.61	94.7	10.91			204	145	Peak
11420	45.87	29.61	16.26	54	-8.13	141	281	Average
11420	55.47	39.21	16.26	74	-18.53	141	281	Peak
Antenna Polarity & Test Distance: Vertical at 3 m								
Frequency (MHz)	Emission Level (dBuV/m)	Read Level (dBuV)	Factor (dB/m)	Limit (dBuV/m)	Margin (dB)	Antenna Height (cm)	Table Angle (Degree)	Remark
5456.72	42.12	31.61	10.51	54	-11.88	174	273	Average
5456.72	52.59	42.08	10.51	74	-21.41	174	273	Peak
*5469.84	51.51	40.98	10.53	68.2	-16.69	174	273	Peak
5710	100.33	89.42	10.91			174	273	Average
5710	107.2	96.29	10.91			174	273	Peak
11420	46.34	30.08	16.26	54	-7.66	159	225	Average
11420	55.93	39.67	16.26	74	-18.07	159	225	Peak

Remarks:

- Emission Level = Read Level + Factor
Margin value = Emission level – Limit value
- 5710 MHz: Fundamental Frequency
- *: Out of Restricted Band
- The emission levels of other frequencies were very low against the limit

EUT Test Condition		Measurement Detail	
Channel	Channel 151	Frequency Range	1 GHz ~ 40 GHz
Input Power	120 Vac, 60 Hz	Detector Function	Peak (PK) Average (AV)
Environmental Conditions	25 deg. C, 65 % RH	Tested By	Charles Hsiao

<Spurious Emission>

Antenna Polarity & Test Distance: Horizontal at 3 m								
Frequency (MHz)	Emission Level (dBuV/m)	Read Level (dBuV)	Factor (dB/m)	Limit (dBuV/m)	Margin (dB)	Antenna Height (cm)	Table Angle (Degree)	Remark
5755	98.58	87.68	10.9			204	145	Average
5755	105.48	94.58	10.9			204	145	Peak
11510	48.16	31.65	16.51	54	-5.84	135	55	Average
11510	55.74	39.23	16.51	74	-18.26	135	55	Peak
Antenna Polarity & Test Distance: Vertical at 3 m								
Frequency (MHz)	Emission Level (dBuV/m)	Read Level (dBuV)	Factor (dB/m)	Limit (dBuV/m)	Margin (dB)	Antenna Height (cm)	Table Angle (Degree)	Remark
5755	99.87	88.97	10.9			174	273	Average
5755	106.08	95.18	10.9			174	273	Peak
11510	48.4	31.89	16.51	54	-5.6	155	196	Average
11510	55.49	38.98	16.51	74	-18.51	155	196	Peak

Antenna Polarity & Test Distance: Horizontal at 3 m								
Frequency (MHz)	Emission Level (dBuV/m)	Read Level (dBuV)	Factor (dB/m)	Limit (dBuV/m)	Margin (dB)	Antenna Height (cm)	Table Angle (Degree)	Remark
*5554.075	52.8	42.14	10.66	68.2	-15.4	204	145	Peak
5653.3	51.65	40.78	10.87	70.64	-18.99	204	145	Peak
5921.05	50.56	39.47	11.09	71.12	-20.56	204	145	Peak
*5971.975	52.13	40.88	11.25	68.2	-16.07	204	145	Peak
Antenna Polarity & Test Distance: Vertical at 3 m								
Frequency (MHz)	Emission Level (dBuV/m)	Read Level (dBuV)	Factor (dB/m)	Limit (dBuV/m)	Margin (dB)	Antenna Height (cm)	Table Angle (Degree)	Remark
*5650.15	53.42	42.55	10.87	68.31	-14.89	174	273	Peak
5666.425	55.78	44.89	10.89	80.35	-24.57	174	273	Peak
5921.575	50.1	38.99	11.11	70.73	-20.63	174	273	Peak
*6005.05	51.99	40.66	11.33	68.2	-16.21	174	273	Peak

Remarks:

- Emission Level = Read Level + Factor
Margin value = Emission level – Limit value
- 5755 MHz: Fundamental Frequency
- *: Out of Restricted Band
- The emission levels of other frequencies were very low against the limit

EUT Test Condition		Measurement Detail	
Channel	Channel 159	Frequency Range	1 GHz ~ 40 GHz
Input Power	120 Vac, 60 Hz	Detector Function	Peak (PK) Average (AV)
Environmental Conditions	25 deg. C, 65 % RH	Tested By	Charles Hsiao

<Spurious Emission>

Antenna Polarity & Test Distance: Horizontal at 3 m								
Frequency (MHz)	Emission Level (dBuV/m)	Read Level (dBuV)	Factor (dB/m)	Limit (dBuV/m)	Margin (dB)	Antenna Height (cm)	Table Angle (Degree)	Remark
5795	100.27	89.45	10.82			204	145	Average
5795	107.1	96.28	10.82			204	145	Peak
11590	48.49	31.98	16.51	54	-5.51	129	99	Average
11590	56.13	39.62	16.51	74	-17.87	129	99	Peak
Antenna Polarity & Test Distance: Vertical at 3 m								
Frequency (MHz)	Emission Level (dBuV/m)	Read Level (dBuV)	Factor (dB/m)	Limit (dBuV/m)	Margin (dB)	Antenna Height (cm)	Table Angle (Degree)	Remark
5795	101.25	90.43	10.82			174	273	Average
5795	108.75	97.93	10.82			174	273	Peak
11590	48.66	32.15	16.51	54	-5.34	135	228	Average
11590	55.48	38.97	16.51	74	-18.52	135	228	Peak

<Out of Band Emission (OOBE)>

Antenna Polarity & Test Distance: Horizontal at 3 m								
Frequency (MHz)	Emission Level (dBuV/m)	Read Level (dBuV)	Factor (dB/m)	Limit (dBuV/m)	Margin (dB)	Antenna Height (cm)	Table Angle (Degree)	Remark
*5595.025	53.14	42.39	10.75	68.2	-15.06	204	145	Peak
5656.45	51.86	40.99	10.87	72.97	-21.11	204	145	Peak
5922.1	51.11	40	11.11	70.35	-19.24	204	145	Peak
*6024.475	52.75	41.38	11.37	68.2	-15.45	204	145	Peak
Antenna Polarity & Test Distance: Vertical at 3 m								
Frequency (MHz)	Emission Level (dBuV/m)	Read Level (dBuV)	Factor (dB/m)	Limit (dBuV/m)	Margin (dB)	Antenna Height (cm)	Table Angle (Degree)	Remark
*5626	53.77	42.98	10.79	68.2	-14.43	174	273	Peak
5663.8	56.89	46	10.89	78.41	-21.52	174	273	Peak
5920	51.58	40.49	11.09	71.9	-20.32	174	273	Peak
*5964.625	54.41	43.18	11.23	68.2	-13.79	174	273	Peak

Remarks:

- Emission Level = Read Level + Factor
Margin value = Emission level – Limit value
- 5795 MHz: Fundamental Frequency
- *: Out of Restricted Band
- The emission levels of other frequencies were very low against the limit

802.11ac (VHT80)

EUT Test Condition		Measurement Detail	
Channel	Channel 42	Frequency Range	1 GHz ~ 40 GHz
Input Power	120 Vac, 60 Hz	Detector Function	Peak (PK) Average (AV)
Environmental Conditions	25 deg. C, 65 % RH	Tested By	Karl Lee

Antenna Polarity & Test Distance: Horizontal at 3 m

Frequency (MHz)	Emission Level (dBuV/m)	Read Level (dBuV)	Factor (dB/m)	Limit (dBuV/m)	Margin (dB)	Antenna Height (cm)	Table Angle (Degree)	Remark
5140.55	49.38	39.37	10.01	54	-4.62	254	356	Average
5140.55	56.54	46.53	10.01	74	-17.46	254	356	Peak
5210	92.25	82.08	10.17			254	356	Average
5210	99.07	88.9	10.17			254	356	Peak
5383.22	43.97	33.63	10.34	54	-10.03	254	356	Average
5383.22	52.9	42.56	10.34	74	-21.1	254	356	Peak
*10420	54.19	38.03	16.16	68.2	-14.01	129	21	Peak

Antenna Polarity & Test Distance: Vertical at 3 m

Frequency (MHz)	Emission Level (dBuV/m)	Read Level (dBuV)	Factor (dB/m)	Limit (dBuV/m)	Margin (dB)	Antenna Height (cm)	Table Angle (Degree)	Remark
5127.65	49.9	39.9	10	54	-4.1	268	71	Average
5127.65	56.38	46.38	10	74	-17.62	268	71	Peak
5210	93.52	83.35	10.17			268	71	Average
5210	100.32	90.15	10.17			268	71	Peak
5372.55	44.14	33.88	10.26	54	-9.86	268	71	Average
5372.55	52.62	42.36	10.26	74	-21.38	268	71	Peak
*10420	54.09	37.93	16.16	68.2	-14.11	158	105	Peak

Remarks:

- Emission Level = Read Level + Factor
Margin value = Emission level – Limit value
- 5210 MHz: Fundamental Frequency
- *: Out of Restricted Band
- The emission levels of other frequencies were very low against the limit

EUT Test Condition		Measurement Detail	
Channel	Channel 58	Frequency Range	1 GHz ~ 40 GHz
Input Power	120 Vac, 60 Hz	Detector Function	Peak (PK) Average (AV)
Environmental Conditions	25 deg. C, 65 % RH	Tested By	Karl Lee

Antenna Polarity & Test Distance: Horizontal at 3 m								
Frequency (MHz)	Emission Level (dBuV/m)	Read Level (dBuV)	Factor (dB/m)	Limit (dBuV/m)	Margin (dB)	Antenna Height (cm)	Table Angle (Degree)	Remark
5119.85	44.42	34.45	9.97	54	-9.58	241	355	Average
5119.85	52.17	42.2	9.97	74	-21.83	241	355	Peak
5290	90.47	80.37	10.1			241	355	Average
5290	98.1	88	10.1			241	355	Peak
5354.84	44.33	34.1	10.23	54	-9.67	241	355	Average
5354.84	52.43	42.2	10.23	74	-21.57	241	355	Peak
*10580	53.86	38.15	15.71	68.2	-14.34	164	15	Peak
Antenna Polarity & Test Distance: Vertical at 3 m								
Frequency (MHz)	Emission Level (dBuV/m)	Read Level (dBuV)	Factor (dB/m)	Limit (dBuV/m)	Margin (dB)	Antenna Height (cm)	Table Angle (Degree)	Remark
5120.15	44.04	34.07	9.97	54	-9.96	200	271	Average
5120.15	52.58	42.61	9.97	74	-21.42	200	271	Peak
5290	92.14	82.04	10.1			200	271	Average
5290	99.99	89.89	10.1			200	271	Peak
5355.61	43.84	33.61	10.23	54	-10.16	200	271	Average
5355.61	52.75	42.52	10.23	74	-21.25	200	271	Peak
*10580	55.03	39.32	15.71	68.2	-13.17	155	285	Peak

Remarks:

- Emission Level = Read Level + Factor
Margin value = Emission level – Limit value
- 5290 MHz: Fundamental Frequency
- *: Out of Restricted Band
- The emission levels of other frequencies were very low against the limit

EUT Test Condition		Measurement Detail	
Channel	Channel 106	Frequency Range	1 GHz ~ 40 GHz
Input Power	120 Vac, 60 Hz	Detector Function	Peak (PK) Average (AV)
Environmental Conditions	25 deg. C, 65 % RH	Tested By	Charles Hsiao

Antenna Polarity & Test Distance: Horizontal at 3 m								
Frequency (MHz)	Emission Level (dBuV/m)	Read Level (dBuV)	Factor (dB/m)	Limit (dBuV/m)	Margin (dB)	Antenna Height (cm)	Table Angle (Degree)	Remark
5454.16	43.46	32.95	10.51	54	-10.54	204	145	Average
5454.16	52.9	42.39	10.51	74	-21.1	204	145	Peak
*5469.36	51.92	41.39	10.53	68.2	-16.28	204	145	Peak
5530	89.59	78.96	10.63			204	145	Average
5530	96.16	85.53	10.63			204	145	Peak
*5725.56	53.01	42.09	10.92	68.2	-15.19	204	145	Peak
11060	44.65	28.42	16.23	54	-9.35	185	247	Average
11060	54.31	38.08	16.23	74	-19.69	185	247	Peak

Antenna Polarity & Test Distance: Vertical at 3 m								
Frequency (MHz)	Emission Level (dBuV/m)	Read Level (dBuV)	Factor (dB/m)	Limit (dBuV/m)	Margin (dB)	Antenna Height (cm)	Table Angle (Degree)	Remark
5458.96	44.22	33.71	10.51	54	-9.78	174	273	Average
5458.96	53.47	42.96	10.51	74	-20.53	174	273	Peak
*5469.2	53.68	43.15	10.53	68.2	-14.52	174	273	Peak
5530	91.47	80.84	10.63			174	273	Average
5530	98.9	88.27	10.63			174	273	Peak
*5725.72	51.86	40.94	10.92	68.2	-16.34	174	273	Peak
11060	44.15	27.92	16.23	54	-9.85	147	134	Average
11060	53.77	37.54	16.23	74	-20.23	147	134	Peak

Remarks:

- Emission Level = Read Level + Factor
Margin value = Emission level – Limit value
- 5530 MHz: Fundamental Frequency
- *: Out of Restricted Band
- The emission levels of other frequencies were very low against the limit

EUT Test Condition		Measurement Detail	
Channel	Channel 122	Frequency Range	1 GHz ~ 40 GHz
Input Power	120 Vac, 60 Hz	Detector Function	Peak (PK) Average (AV)
Environmental Conditions	25 deg. C, 65 % RH	Tested By	Charles Hsiao

Antenna Polarity & Test Distance: Horizontal at 3 m								
Frequency (MHz)	Emission Level (dBuV/m)	Read Level (dBuV)	Factor (dB/m)	Limit (dBuV/m)	Margin (dB)	Antenna Height (cm)	Table Angle (Degree)	Remark
5454.96	43.71	33.2	10.51	54	-10.29	204	145	Average
5454.96	53.78	43.27	10.51	74	-20.22	204	145	Peak
*5469.36	52.6	42.07	10.53	68.2	-15.6	204	145	Peak
5610	95.58	84.81	10.77			204	145	Average
5610	102.19	91.42	10.77			204	145	Peak
*5725.88	54.1	43.18	10.92	68.2	-14.1	204	145	Peak
11220	46.89	30.47	16.42	54	-7.11	139	256	Average
11220	56.53	40.11	16.42	74	-17.47	139	256	Peak

Antenna Polarity & Test Distance: Vertical at 3 m								
Frequency (MHz)	Emission Level (dBuV/m)	Read Level (dBuV)	Factor (dB/m)	Limit (dBuV/m)	Margin (dB)	Antenna Height (cm)	Table Angle (Degree)	Remark
5459.92	44.84	34.33	10.51	54	-9.16	174	273	Average
5459.92	53.75	43.24	10.51	74	-20.25	174	273	Peak
*5469.52	53.49	42.96	10.53	68.2	-14.71	174	273	Peak
5610	98.59	87.82	10.77			174	273	Average
5610	105.07	94.3	10.77			174	273	Peak
*5725.8	55.67	44.75	10.92	68.2	-12.53	174	273	Peak
11220	47.21	30.79	16.42	54	-6.79	141	127	Average
11220	56.85	40.43	16.42	74	-17.15	141	127	Peak

Remarks:

- Emission Level = Read Level + Factor
Margin value = Emission level – Limit value
- 5610 MHz: Fundamental Frequency
- *: Out of Restricted Band
- The emission levels of other frequencies were very low against the limit

EUT Test Condition		Measurement Detail	
Channel	Channel 138	Frequency Range	1 GHz ~ 40 GHz
Input Power	120 Vac, 60 Hz	Detector Function	Peak (PK) Average (AV)
Environmental Conditions	25 deg. C, 65 % RH	Tested By	Charles Hsiao

Antenna Polarity & Test Distance: Horizontal at 3 m								
Frequency (MHz)	Emission Level (dBuV/m)	Read Level (dBuV)	Factor (dB/m)	Limit (dBuV/m)	Margin (dB)	Antenna Height (cm)	Table Angle (Degree)	Remark
5459.44	44.24	33.73	10.51	54	-9.76	204	145	Average
5459.44	54.95	44.44	10.51	74	-19.05	204	145	Peak
*5469.04	54.13	43.6	10.53	68.2	-14.07	204	145	Peak
5690	96.55	85.62	10.93			204	145	Average
5690	103.49	92.56	10.93			204	145	Peak
11380	46.68	30.41	16.27	54	-7.32	175	164	Average
11380	56.21	39.94	16.27	74	-17.79	175	164	Peak
Antenna Polarity & Test Distance: Vertical at 3 m								
Frequency (MHz)	Emission Level (dBuV/m)	Read Level (dBuV)	Factor (dB/m)	Limit (dBuV/m)	Margin (dB)	Antenna Height (cm)	Table Angle (Degree)	Remark
5459.76	44.79	34.28	10.51	54	-9.21	174	273	Average
5459.76	55.04	44.53	10.51	74	-18.96	174	273	Peak
*5470	53.65	43.12	10.53	68.2	-14.55	174	273	Peak
5690	98.85	87.92	10.93			174	273	Average
5690	105.66	94.73	10.93			174	273	Peak
11380	46.19	29.92	16.27	54	-7.81	160	218	Average
11380	55.69	39.42	16.27	74	-18.31	160	218	Peak

Remarks:

- Emission Level = Read Level + Factor
Margin value = Emission level – Limit value
- 5690 MHz: Fundamental Frequency
- *: Out of Restricted Band
- The emission levels of other frequencies were very low against the limit

EUT Test Condition		Measurement Detail	
Channel	Channel 155	Frequency Range	1 GHz ~ 40 GHz
Input Power	120 Vac, 60 Hz	Detector Function	Peak (PK) Average (AV)
Environmental Conditions	25 deg. C, 65 % RH	Tested By	Charles Hsiao

<Spurious Emission>

Antenna Polarity & Test Distance: Horizontal at 3 m								
Frequency (MHz)	Emission Level (dBuV/m)	Read Level (dBuV)	Factor (dB/m)	Limit (dBuV/m)	Margin (dB)	Antenna Height (cm)	Table Angle (Degree)	Remark
5775	91.19	80.32	10.87			204	145	Average
5775	98.68	87.81	10.87			204	145	Peak
11550	48.39	31.89	16.5	54	-5.61	171	278	Average
11550	55.67	39.17	16.5	74	-18.33	171	278	Peak
Antenna Polarity & Test Distance: Vertical at 3 m								
Frequency (MHz)	Emission Level (dBuV/m)	Read Level (dBuV)	Factor (dB/m)	Limit (dBuV/m)	Margin (dB)	Antenna Height (cm)	Table Angle (Degree)	Remark
5775	92.11	81.24	10.87			174	273	Average
5775	99	88.13	10.87			174	273	Peak
11550	48.5	32	16.5	54	-5.5	162	326	Average
11550	55.86	39.36	16.5	74	-18.14	162	326	Peak

<Out of Band Emission (OOBE)>

Antenna Polarity & Test Distance: Horizontal at 3 m								
Frequency (MHz)	Emission Level (dBuV/m)	Read Level (dBuV)	Factor (dB/m)	Limit (dBuV/m)	Margin (dB)	Antenna Height (cm)	Table Angle (Degree)	Remark
*5581.9	52.51	41.78	10.73	68.2	-15.69	204	145	Peak
5652.25	51.1	40.23	10.87	69.86	-18.76	204	145	Peak
5921.575	48.91	37.8	11.11	70.73	-21.82	204	145	Peak
*5991.4	52.76	41.43	11.33	68.2	-15.44	204	145	Peak
Antenna Polarity & Test Distance: Vertical at 3 m								
Frequency (MHz)	Emission Level (dBuV/m)	Read Level (dBuV)	Factor (dB/m)	Limit (dBuV/m)	Margin (dB)	Antenna Height (cm)	Table Angle (Degree)	Remark
*5546.725	52.57	41.91	10.66	68.2	-15.63	174	273	Peak
5654.875	53.45	42.58	10.87	71.81	-18.36	174	273	Peak
5918.95	50.87	39.78	11.09	72.68	-21.81	174	273	Peak
*5927.875	52.16	41.05	11.11	68.2	-16.04	174	273	Peak

Remarks:

- Emission Level = Read Level + Factor
Margin value = Emission level – Limit value
- 5775 MHz: Fundamental Frequency
- *: Out of Restricted Band
- The emission levels of other frequencies were very low against the limit

802.11ac (VHT160)

EUT Test Condition		Measurement Detail	
Channel	Channel 50	Frequency Range	1 GHz ~ 40 GHz
Input Power	120 Vac, 60 Hz	Detector Function	Peak (PK) Average (AV)
Environmental Conditions	25 deg. C, 65 % RH	Tested By	Karl Lee

Antenna Polarity & Test Distance: Horizontal at 3 m								
Frequency (MHz)	Emission Level (dBuV/m)	Read Level (dBuV)	Factor (dB/m)	Limit (dBuV/m)	Margin (dB)	Antenna Height (cm)	Table Angle (Degree)	Remark
5143.55	48.37	38.34	10.03	54	-5.63	254	354	Average
5143.55	56.06	46.03	10.03	74	-17.94	254	354	Peak
5250	89.5	79.4	10.1			254	354	Average
5250	96.77	86.67	10.1			254	354	Peak
5402.25	51.89	41.49	10.4	54	-2.11	254	354	Average
5402.25	58.37	47.97	10.4	74	-15.63	254	354	Peak
*10500	53.99	38.16	15.83	68.2	-14.21	147	236	Peak

Antenna Polarity & Test Distance: Vertical at 3 m								
Frequency (MHz)	Emission Level (dBuV/m)	Read Level (dBuV)	Factor (dB/m)	Limit (dBuV/m)	Margin (dB)	Antenna Height (cm)	Table Angle (Degree)	Remark
5138.9	49.13	39.13	10	54	-4.87	268	71	Average
5138.9	57.95	47.95	10	74	-16.05	268	71	Peak
5250	91.37	81.27	10.1			268	71	Average
5250	97.93	87.83	10.1			268	71	Peak
5402.47	52.43	42.03	10.4	54	-1.57	268	71	Average
5402.47	59.23	48.83	10.4	74	-14.77	268	71	Peak
*10500	53.61	37.78	15.83	68.2	-14.59	169	216	Peak

Remarks:

- Emission Level = Read Level + Factor
Margin value = Emission level – Limit value
- 5250 MHz: Fundamental Frequency
- *: Out of Restricted Band
- The emission levels of other frequencies were very low against the limit

EUT Test Condition		Measurement Detail	
Channel	Channel 114	Frequency Range	1 GHz ~ 40 GHz
Input Power	120 Vac, 60 Hz	Detector Function	Peak (PK) Average (AV)
Environmental Conditions	25 deg. C, 65 % RH	Tested By	Charles Hsiao

Antenna Polarity & Test Distance: Horizontal at 3 m								
Frequency (MHz)	Emission Level (dBuV/m)	Read Level (dBuV)	Factor (dB/m)	Limit (dBuV/m)	Margin (dB)	Antenna Height (cm)	Table Angle (Degree)	Remark
5459.28	44.01	33.5	10.51	54	-9.99	204	145	Average
5459.28	53.37	42.86	10.51	74	-20.63	204	145	Peak
*5469.2	51.75	41.22	10.53	68.2	-16.45	204	145	Peak
5570	87.41	76.71	10.7			204	145	Average
5570	94.52	83.82	10.7			204	145	Peak
*5725.64	52.46	41.54	10.92	68.2	-15.74	204	145	Peak
11140	45.96	29.62	16.34	54	-8.04	168	256	Average
11140	55.49	39.15	16.34	74	-18.51	168	256	Peak

Antenna Polarity & Test Distance: Vertical at 3 m								
Frequency (MHz)	Emission Level (dBuV/m)	Read Level (dBuV)	Factor (dB/m)	Limit (dBuV/m)	Margin (dB)	Antenna Height (cm)	Table Angle (Degree)	Remark
5453.68	45.65	35.14	10.51	54	-8.35	174	273	Average
5453.68	53.27	42.76	10.51	74	-20.73	174	273	Peak
*5469.36	52.12	41.59	10.53	68.2	-16.08	174	273	Peak
5570	89.59	78.89	10.7			174	273	Average
5570	96.1	85.4	10.7			174	273	Peak
*5725.96	52.63	41.71	10.92	68.2	-15.57	174	273	Peak
11140	45.48	29.14	16.34	54	-8.52	154	108	Average
11140	55.03	38.69	16.34	74	-18.97	154	108	Peak

Remarks:

- Emission Level = Read Level + Factor
Margin value = Emission level – Limit value
- 5570 MHz: Fundamental Frequency
- *: Out of Restricted Band
- The emission levels of other frequencies were very low against the limit

9 kHz ~ 30 MHz Data:

The amplitude of spurious emissions attenuated more than 20 dB below the permissible value is not required to be report.

30 MHz ~ 1 GHz Worst-Case Data:

802.11n (HT40)

EUT Test Condition		Measurement Detail	
Channel	Channel 38	Frequency Range	30 MHz ~ 1 GHz
Input Power	120 Vac, 60 Hz	Detector Function	Peak (PK) Quasi-peak (QP)
Environmental Conditions	25 deg. C, 65 % RH	Tested By	Karl Lee

Horizontal

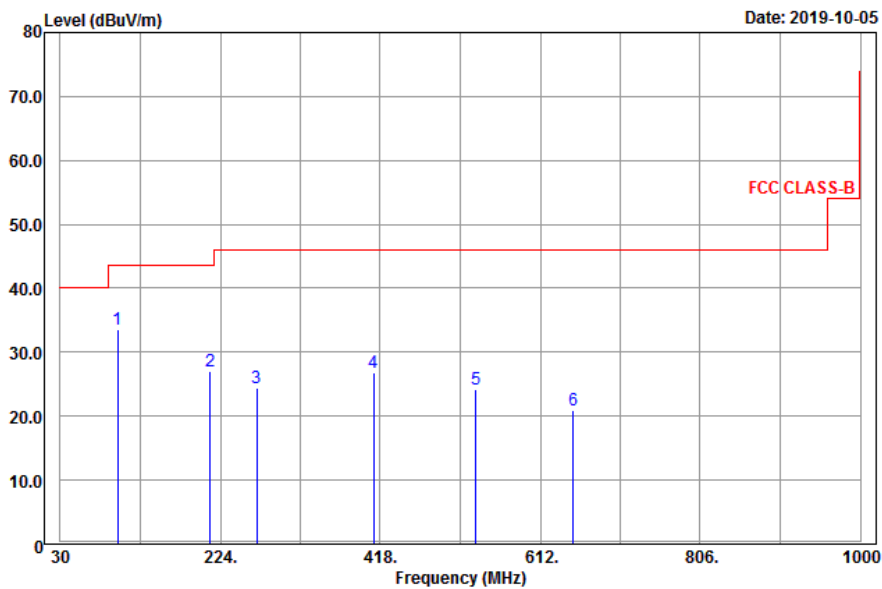

Vertical

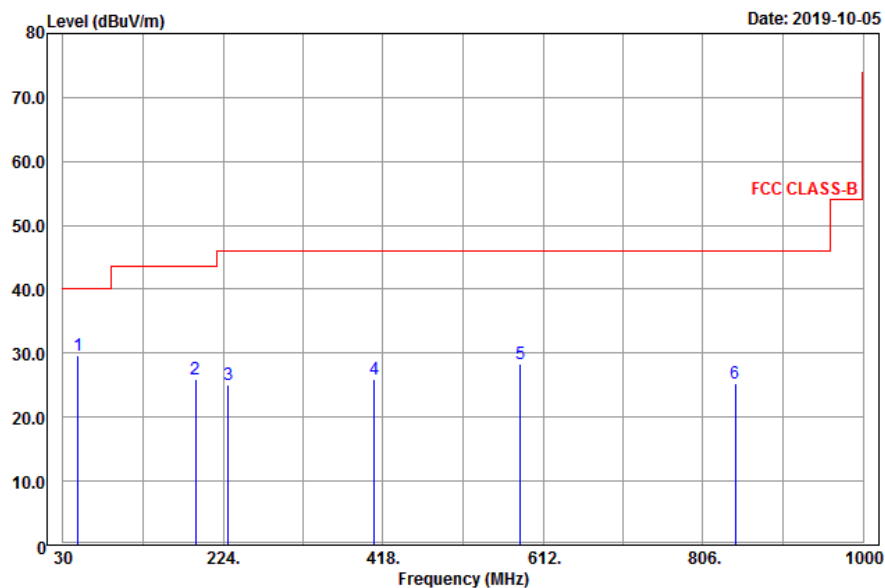

Antenna Polarity & Test Distance: Horizontal at 3 m								
Frequency (MHz)	Emission Level (dBuV/m)	Read Level (dBuV)	Factor (dB/m)	Limit (dBuV/m)	Margin (dB)	Antenna Height (cm)	Table Angle (Degree)	Remark
99.93	33.52	50.72	-17.2	43.5	-9.98	180	77	Peak
211.44	27	45.11	-18.11	43.5	-16.5	163	326	Peak
268.41	24.39	40.93	-16.54	46	-21.61	174	111	Peak
409.9	26.78	40.53	-13.75	46	-19.22	149	199	Peak
533.8	24.25	36.08	-11.83	46	-21.75	105	25	Peak
652.1	20.87	30.9	-10.03	46	-25.13	165	55	Peak
Antenna Polarity & Test Distance: Vertical at 3 m								
Frequency (MHz)	Emission Level (dBuV/m)	Read Level (dBuV)	Factor (dB/m)	Limit (dBuV/m)	Margin (dB)	Antenna Height (cm)	Table Angle (Degree)	Remark
48.09	29.55	44.69	-15.14	40	-10.45	149	99	Peak
190.65	25.97	44.62	-18.65	43.5	-17.53	106	33	Peak
230.07	24.99	42.38	-17.39	46	-21.01	177	108	Peak
407.1	25.88	39.69	-13.81	46	-20.12	104	174	Peak
584.2	28.38	39.28	-10.9	46	-17.62	185	196	Peak
845.3	25.32	32.19	-6.87	46	-20.68	105	222	Peak

Remarks:

- Emission Level = Read Level + Factor
Margin value = Emission level – Limit value
- The emission levels of other frequencies were very low against the limit

4.2 Conducted Emission Measurement

4.2.1 Limits of Conducted Emission Measurement

Frequency (MHz)	Conducted Limit (dBuV)	
	Quasi-Peak	Average
0.15 - 0.5	66 - 56	56 - 46
0.50 - 5.0	56	46
5.0 - 30.0	60	50

- Note: 1. The lower limit shall apply at the transition frequencies.
 2. The limit decreases in line with the logarithm of the frequency in the range of 0.15 to 0.50 MHz.

4.2.2 Test Instruments

Description & Manufacturer	Model No.	Serial No.	Date of Calibration	Due Date of Calibration
Test Receiver ROHDE & SCHWARZ	ESCI	100613	Dec. 10, 2018	Dec. 09, 2019
RF signal cable Woken	5D-FB	Cable-cond1-01	Sep. 05, 2019	Sep. 04, 2020
LISN ROHDE & SCHWARZ (EUT)	ENV216	101826	Feb. 21, 2019	Feb. 20, 2020
LISN ROHDE & SCHWARZ (Peripheral)	ESH3-Z5	100311	Aug. 22, 2019	Aug. 21, 2020
Software ADT	BV ADT_Cond_ V7.3.7.4	NA	NA	NA

- Note: 1. The calibration interval of the above test instruments is 12 months and the calibrations are traceable to NML/ROC and NIST/USA.
 2. The test was performed in HwaYa Shielded Room 1.
 3. The VCCI Site Registration No. is C-12040.

4.2.3 Test Procedures

- a. The EUT was placed 0.4 meters from the conducting wall of the shielded room with EUT being connected to the power mains through a line impedance stabilization network (LISN). Other support units were connected to the power mains through another LISN. The two LISNs provide 50 ohm/ 50uH of coupling impedance for the measuring instrument.
- b. Both lines of the power mains connected to the EUT were checked for maximum conducted interference.
- c. The frequency range from 150 kHz to 30 MHz was searched. Emission levels under (Limit -20 dB) was not recorded.

Note: All modes of operation were investigated and the worst-case emissions are reported.

4.2.4 Deviation from Test Standard

No deviation.

4.2.5 Test Setup

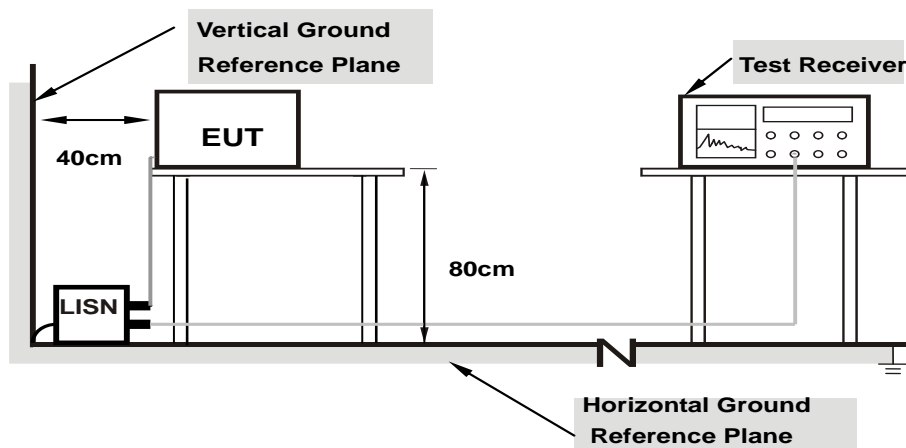

- Note:**
1. Support units were connected to second LISN.
 2. Both of LISNs (AMN) are 80 cm from EUT and at least 80 cm from other units and other metal planes

For the actual test configuration, please refer to the attached file (Test Setup Photo).

4.2.6 EUT Operating Conditions

- a. Placed the EUT on a testing table.
- b. Use the software to control the EUT under transmission condition continuously at specific channel frequency.

4.2.7 Test Results

Frequency Range	150kHz ~ 30MHz	Detector Function & Resolution Bandwidth	Quasi-Peak (QP) / Average (AV), 9kHz
Input Power	120Vac, 60Hz	Environmental Conditions	22°C, 66%RH
Tested by	Getaz Yang	Test Date	2019/10/8

Phase Of Power : Line (L)										
No	Frequency (MHz)	Correction Factor (dB)	Reading Value (dBuV)		Emission Level (dBuV)		Limit (dBuV)		Margin (dB)	
			Q.P.	AV.	Q.P.	AV.	Q.P.	AV.	Q.P.	AV.
1	0.15900	10.11	34.21	15.45	44.32	25.56	65.52	55.52	-21.20	-29.96
2	0.21300	10.12	24.56	10.28	34.68	20.40	63.09	53.09	-28.41	-32.69
3	0.55725	10.18	22.12	11.27	32.30	21.45	56.00	46.00	-23.70	-24.55
4	2.09400	10.26	18.84	6.59	29.10	16.85	56.00	46.00	-26.90	-29.15
5	3.20775	10.31	21.42	9.35	31.73	19.66	56.00	46.00	-24.27	-26.34
6	11.48100	10.46	25.65	10.78	36.11	21.24	60.00	50.00	-23.89	-28.76

Remarks:

1. Q.P. and AV. are abbreviations of quasi-peak and average individually.
2. The emission levels of other frequencies were very low against the limit.
3. Margin value = Emission level – Limit value
4. Correction factor = Insertion loss + Cable loss
5. Emission Level = Correction Factor + Reading Value

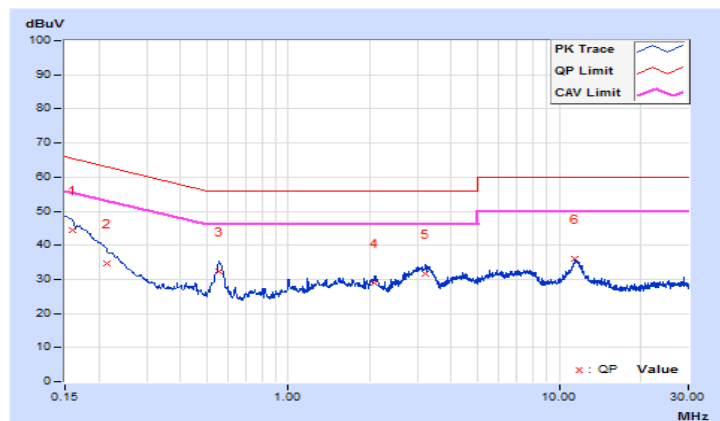

Frequency Range	150kHz ~ 30MHz	Detector Function & Resolution Bandwidth	Quasi-Peak (QP) / Average (AV), 9kHz
Input Power	120Vac, 60Hz	Environmental Conditions	22°C, 66%RH
Tested by	Getaz Yang	Test Date	2019/10/8

Phase Of Power : Neutral (N)										
No	Frequency (MHz)	Correction Factor (dB)	Reading Value (dBuV)		Emission Level (dBuV)		Limit (dBuV)		Margin (dB)	
			Q.P.	AV.	Q.P.	AV.	Q.P.	AV.	Q.P.	AV.
1	0.15225	10.16	35.33	17.83	45.49	27.99	65.88	55.88	-20.39	-27.89
2	0.20850	10.18	25.83	10.28	36.01	20.46	63.26	53.26	-27.25	-32.80
3	0.56175	10.24	23.83	10.28	34.07	20.52	56.00	46.00	-21.93	-25.48
4	1.95450	10.32	19.08	8.34	29.40	18.66	56.00	46.00	-26.60	-27.34
5	5.45100	10.45	20.18	7.00	30.63	17.45	60.00	50.00	-29.37	-32.55
6	11.52600	10.58	21.79	9.31	32.37	19.89	60.00	50.00	-27.63	-30.11

Remarks:

1. Q.P. and AV. are abbreviations of quasi-peak and average individually.
2. The emission levels of other frequencies were very low against the limit.
3. Margin value = Emission level – Limit value
4. Correction factor = Insertion loss + Cable loss
5. Emission Level = Correction Factor + Reading Value

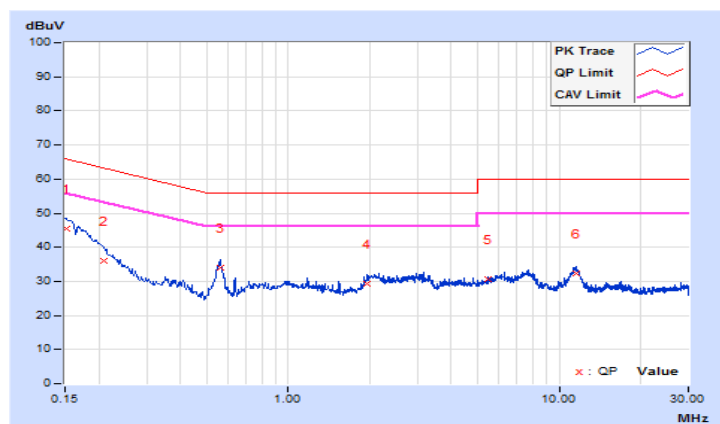

4.3 Transmit Power Measurement

4.3.1 Limits of Transmit Power Measurement

Operation Band	EUT Category		Limit
U-NII-1		Outdoor Access Point	1 Watt (30 dBm) (Max. e.i.r.p \leq 125 mW (21 dBm) at any elevation angle above 30 degrees as measured from the horizon)
		Fixed point-to-point Access Point	1 Watt (30 dBm)
		Indoor Access Point	1 Watt (30 dBm)
	√	Mobile and Portable client device	250 mW (24 dBm)
U-NII-2A		√	250 mW (24 dBm) or 11 dBm + 10 log B*
U-NII-2C		√	250 mW (24 dBm) or 11 dBm + 10 log B*
U-NII-3		√	1 Watt (30 dBm)

*B is the 26 dB emission bandwidth in megahertz

Per KDB 662911 Method of conducted output power measurement on IEEE 802.11 devices,

Array Gain = 0 dB (i.e., no array gain) for $N_{ANT} \leq 4$;

Array Gain = 0 dB (i.e., no array gain) for channel widths ≥ 40 MHz for any N_{ANT} ;

Array Gain = $5 \log(N_{ANT}/N_{SS})$ dB or 3 dB, whichever is less for 20 MHz channel widths with $N_{ANT} \geq 5$.

For power measurements on all other devices: Array Gain = $10 \log(N_{ANT}/N_{SS})$ dB.

4.3.2 Test Setup

<Power Output Measurement>

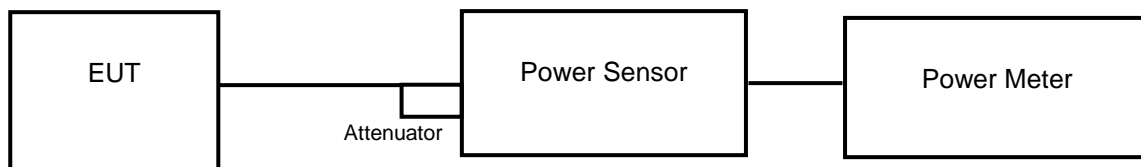

or

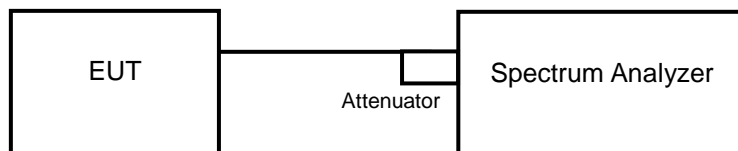

<26 dB Bandwidth>

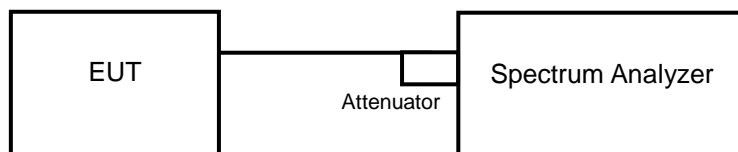

4.3.3 Test Instruments

Refer to section 4.1.2 to get information of above instrument.

4.3.4 Test Procedure

Average Power Measurement

<802.11a, 802.11n (HT20), 802.11n (HT40)>

Method PM is used to perform output power measurement, trigger and gating function of wide band power meter is enabled to measure max output power of TX on burst. Duty factor is not added to measured value.

<802.11ac (VHT80), 802.11ac (VHT160)>

- a. Set span to encompass the entire 26 dB EBW (or, alternatively, the entire 99 % occupied bandwidth) of the signal.
- b. Set sweep trigger to “free run”.
- c. Set RBW = 1 MHz.
- d. Set VBW \geq 3 MHz
- e. Number of points in sweep \geq 2 Span / RBW.
- f. Sweep time \leq (number of points in sweep) * T
- g. Using emission bandwidth to determine the frequency span for integration the channel bandwidth.
- h. Detector = RMS.
- i. Trace mode = max hold.
- j. Allow max hold to run for at least 60 seconds, or longer as needed to allow the trace to stabilize.
- k. Compute power by integrating the spectrum across the EBW (or, alternatively, the entire 99% occupied bandwidth) of the signal using the instrument’s band power measurement function with band limits set equal to the EBW (or occupied bandwidth) band edges. If the instrument does not have a band power function, sum the spectrum levels (in power units) at 1 MHz intervals extending across the EBW (or, alternatively, the entire 99% occupied bandwidth) of the spectrum
- l.

26 dB Bandwidth

- a. Set RBW = approximately 1 % of the emission bandwidth.
- b. Set the VBW > RBW.
- c. Detector = Peak.
- d. Trace mode = max hold.
- e. Measure the maximum width of the emission that is 26 dB down from the peak of the emission. Compare this with the RBW setting of the analyzer. Readjust RBW and repeat measurement as needed until the RBW/EBW ratio is approximately 1 %.

4.3.5 Deviation from Test Standard

No deviation.

4.3.6 EUT Operating Conditions

The software provided by client to enable the EUT under transmission condition continuously at lowest, middle and highest channel frequencies individually.

4.3.7 Test Results

Power Output:

802.11a

Channel	Frequency (MHz)	Maximum Conducted Power (mW)	Maximum Conducted Power (dBm)	Power Limit (dBm)	Pass / Fail
36	5180	69.663	18.43	24	Pass
40	5200	137.088	21.37	24	Pass
48	5240	124.451	20.95	24	Pass
52	5260	133.352	21.25	24	Pass
60	5300	132.434	21.22	24	Pass
64	5320	57.943	17.63	24	Pass
100	5500	48.306	16.84	24	Pass
116	5580	48.084	16.82	24	Pass
140	5700	75.162	18.76	24	Pass
149	5745	142.233	21.53	30	Pass
157	5785	139.316	21.44	30	Pass
165	5825	140.605	21.48	30	Pass

Note:

For U-NII-2A, U-NII-2C Band:

1. $11 \text{ dBm} + 10\log (27.25) = 25.35 \text{ dBm} > 24 \text{ dBm}$.
2. $11 \text{ dBm} + 10\log (26.80) = 25.28 \text{ dBm} > 24 \text{ dBm}$.
3. $11 \text{ dBm} + 10\log (23.87) = 24.78 \text{ dBm} > 24 \text{ dBm}$.
4. $11 \text{ dBm} + 10\log (24.20) = 24.84 \text{ dBm} > 24 \text{ dBm}$.
5. $11 \text{ dBm} + 10\log (24.16) = 24.83 \text{ dBm} > 24 \text{ dBm}$.
6. $11 \text{ dBm} + 10\log (23.95) = 24.79 \text{ dBm} > 24 \text{ dBm}$.

802.11n (HT20)

Channel	Frequency (MHz)	Maximum Conducted Power (dBm)		Total Power (mW)	Total Power (dBm)	Power Limit (dBm)	Pass / Fail
		Chain 0	Chain 1				
36	5180	15.66	15.81	74.92	18.75	24	Pass
40	5200	18.15	18.20	131.382	21.19	24	Pass
48	5240	18.03	18.12	128.396	21.09	24	Pass
52	5260	18.13	18.28	132.311	21.22	24	Pass
60	5300	18.21	18.14	131.385	21.19	24	Pass
64	5320	15.27	15.43	68.565	18.36	24	Pass
100	5500	15.55	15.87	74.529	18.72	24	Pass
116	5580	15.61	15.77	74.149	18.70	24	Pass
140	5700	17.75	17.83	120.24	20.80	24	Pass
144	5720 (U-NII-2C)	16.87	17.01	98.875	19.95	23.32	Pass
144	5720 (U-NII-3)	12.90	13.09	39.868	16.01	30	Pass
149	5745	20.16	20.24	209.435	23.21	30	Pass
157	5785	20.11	20.23	208.004	23.18	30	Pass
165	5825	20.32	20.51	220.107	23.43	30	Pass

Note:

For U-NII-2A, U-NII-2C Band:

Chain 0

1. $11 \text{ dBm} + 10\log (24.20) = 24.84 \text{ dBm} > 24 \text{ dBm}$.
2. $11 \text{ dBm} + 10\log (24.20) = 24.84 \text{ dBm} > 24 \text{ dBm}$.
3. $11 \text{ dBm} + 10\log (24.06) = 24.81 \text{ dBm} > 24 \text{ dBm}$.
4. $11 \text{ dBm} + 10\log (24.81) = 24.95 \text{ dBm} > 24 \text{ dBm}$.
5. $11 \text{ dBm} + 10\log (24.91) = 24.96 \text{ dBm} > 24 \text{ dBm}$.
6. $11 \text{ dBm} + 10\log (24.85) = 24.95 \text{ dBm} > 24 \text{ dBm}$.
7. $11 \text{ dBm} + 10\log (17.61) = 23.46 \text{ dBm} < 24 \text{ dBm}$.

Chain 1

1. $11 \text{ dBm} + 10\log (23.92) = 24.79 \text{ dBm} > 24 \text{ dBm}$.
2. $11 \text{ dBm} + 10\log (24.37) = 24.87 \text{ dBm} > 24 \text{ dBm}$.
3. $11 \text{ dBm} + 10\log (24.63) = 24.91 \text{ dBm} > 24 \text{ dBm}$.
4. $11 \text{ dBm} + 10\log (24.06) = 24.81 \text{ dBm} > 24 \text{ dBm}$.
5. $11 \text{ dBm} + 10\log (24.13) = 24.83 \text{ dBm} > 24 \text{ dBm}$.
6. $11 \text{ dBm} + 10\log (24.85) = 24.95 \text{ dBm} > 24 \text{ dBm}$.
7. $11 \text{ dBm} + 10\log (17.05) = 23.32 \text{ dBm} < 24 \text{ dBm}$.

802.11n (HT40)

Channel	Frequency (MHz)	Maximum Conducted Power (dBm)		Total Power (mW)	Total Power (dBm)	Power Limit (dBm)	Pass / Fail
		Chain 0	Chain 1				
38	5190	16.34	16.21	84.836	19.29	24	Pass
46	5230	18.49	18.21	136.854	21.36	24	Pass
54	5270	18.21	17.94	128.452	21.09	24	Pass
62	5310	14.17	14.22	52.546	17.21	24	Pass
102	5510	13.61	13.34	44.538	16.49	24	Pass
110	5550	13.62	13.41	44.942	16.53	24	Pass
134	5670	17.77	17.56	116.857	20.68	24	Pass
142	5710 (U-NII-2C)	17.99	17.92	124.895	20.97	24	Pass
142	5710 (U-NII-3)	11.21	10.79	25.208	14.02	30	Pass
151	5755	17.44	17.42	110.671	20.44	30	Pass
159	5795	20.21	19.93	203.355	23.08	30	Pass

Note:

For U-NII-2A, U-NII-2C Band:

Chain 0

1. $11 \text{ dBm} + 10\log (44.99) = 27.53 \text{ dBm} > 24 \text{ dBm}$.
2. $11 \text{ dBm} + 10\log (42.97) = 27.33 \text{ dBm} > 24 \text{ dBm}$.
3. $11 \text{ dBm} + 10\log (45.04) = 27.54 \text{ dBm} > 24 \text{ dBm}$.
4. $11 \text{ dBm} + 10\log (45.30) = 27.56 \text{ dBm} > 24 \text{ dBm}$.
5. $11 \text{ dBm} + 10\log (45.57) = 27.59 \text{ dBm} > 24 \text{ dBm}$.
6. $11 \text{ dBm} + 10\log (37.85) = 26.78 \text{ dBm} > 24 \text{ dBm}$.

Chain 1

1. $11 \text{ dBm} + 10\log (44.10) = 27.44 \text{ dBm} > 24 \text{ dBm}$.
2. $11 \text{ dBm} + 10\log (42.46) = 27.28 \text{ dBm} > 24 \text{ dBm}$.
3. $11 \text{ dBm} + 10\log (43.93) = 27.43 \text{ dBm} > 24 \text{ dBm}$.
4. $11 \text{ dBm} + 10\log (44.16) = 27.45 \text{ dBm} > 24 \text{ dBm}$.
5. $11 \text{ dBm} + 10\log (44.90) = 27.52 \text{ dBm} > 24 \text{ dBm}$.
6. $11 \text{ dBm} + 10\log (37.49) = 26.74 \text{ dBm} > 24 \text{ dBm}$.

802.11ac (VHT80)

Channel	Frequency (MHz)	Maximum Conducted Power (dBm)		Total Power (mW)	Total Power (dBm)	Power Limit (dBm)	Pass / Fail
		Chain 0	Chain 1				
42	5210	14.97	14.45	59.266	17.73	24	Pass
58	5290	11.61	11.66	29.143	14.65	24	Pass
106	5530	11.63	11.67	29.244	14.66	24	Pass
122	5610	17.57	17.24	110.114	20.42	24	Pass
138	5690 (U-NII-2C)	18.41	18.48	139.812	21.46	24	Pass
138	5690 (U-NII-3)	8.61	8.75	14.76	11.69	30	Pass
155	5775	13.56	13.31	44.128	16.45	30	Pass

Note:

For U-NII-2A, U-NII-2C Band:

Chain 0

1. $11 \text{ dBm} + 10\log(86.40) = 30.37 \text{ dBm} > 24 \text{ dBm}$.
2. $11 \text{ dBm} + 10\log(86.88) = 30.39 \text{ dBm} > 24 \text{ dBm}$.
3. $11 \text{ dBm} + 10\log(85.53) = 30.32 \text{ dBm} > 24 \text{ dBm}$.
4. $11 \text{ dBm} + 10\log(78.21) = 29.93 \text{ dBm} > 24 \text{ dBm}$.

Chain 1

1. $11 \text{ dBm} + 10\log(86.26) = 30.36 \text{ dBm} > 24 \text{ dBm}$.
2. $11 \text{ dBm} + 10\log(87.92) = 30.44 \text{ dBm} > 24 \text{ dBm}$.
3. $11 \text{ dBm} + 10\log(86.80) = 30.39 \text{ dBm} > 24 \text{ dBm}$.
4. $11 \text{ dBm} + 10\log(77.62) = 29.90 \text{ dBm} > 24 \text{ dBm}$.

802.11ac (VHT160)

Channel	Frequency (MHz)	Maximum Conducted Power (dBm)		Total Power (mW)	Total Power (dBm)	Power Limit (dBm)	Pass / Fail
		Chain 0	Chain 1				
50	5250	13.44	13.35	43.707	16.41	24	Pass
114	5570	10.87	11.24	25.523	14.07	24	Pass

Note:

For U-NII-2A, U-NII-2C Band:

Chain 0

1. $11 \text{ dBm} + 10\log(164.97) = 33.17 \text{ dBm} > 24 \text{ dBm}$.
2. $11 \text{ dBm} + 10\log(165.00) = 33.17 \text{ dBm} > 24 \text{ dBm}$.

Chain 1

1. $11 \text{ dBm} + 10\log(164.59) = 33.16 \text{ dBm} > 24 \text{ dBm}$.
2. $11 \text{ dBm} + 10\log(164.93) = 33.17 \text{ dBm} > 24 \text{ dBm}$.

26 dB Bandwidth:
802.11a

Channel	Frequency (MHz)	26 dBc Bandwidth (MHz)
36	5180	33.87
40	5200	26.77
48	5240	27.66
52	5260	27.25
60	5300	26.80
64	5320	23.87
100	5500	24.20
116	5580	24.16
140	5700	23.95

802.11n (HT20)

Channel	Frequency (MHz)	26 dBc Bandwidth (MHz)	
		Chain 0	Chain 1
36	5180	24.66	24.11
40	5200	24.23	24.24
48	5240	24.91	24.06
52	5260	24.20	23.92
60	5300	24.20	24.37
64	5320	24.06	24.63
100	5500	24.81	24.06
116	5580	24.91	24.13
140	5700	24.85	24.85
144	5720 (U-NII-2C)	17.61	17.05
144	5720 (U-NII-3)	7.06	6.90

802.11n (HT40)

Channel	Frequency (MHz)	26 dBc Bandwidth (MHz)	
		Chain 0	Chain 1
38	5190	44.95	44.46
46	5230	44.86	43.62
54	5270	44.99	44.10
62	5310	42.97	42.46
102	5510	45.04	43.93
110	5550	45.30	44.16
134	5670	45.57	44.90
142	5710 (U-NII-2C)	37.85	37.49
142	5710 (U-NII-3)	7.94	7.25

802.11ac (VHT80)

Channel	Frequency (MHz)	26 dBc Bandwidth (MHz)	
		Chain 0	Chain 1
42	5210	84.54	84.32
58	5290	86.40	86.26
106	5530	86.88	87.92
122	5610	85.53	86.80
138	5690 (U-NII-2C)	78.21	77.62
138	5690 (U-NII-3)	8.19	8.25

802.11ac (VHT10)

Channel	Frequency (MHz)	26 dBc Bandwidth (MHz)	
		Chain 0	Chain 1
50	5250	164.97	164.59
114	5570	165.00	164.93

Spectrum Plot of Worst Value

802.11a

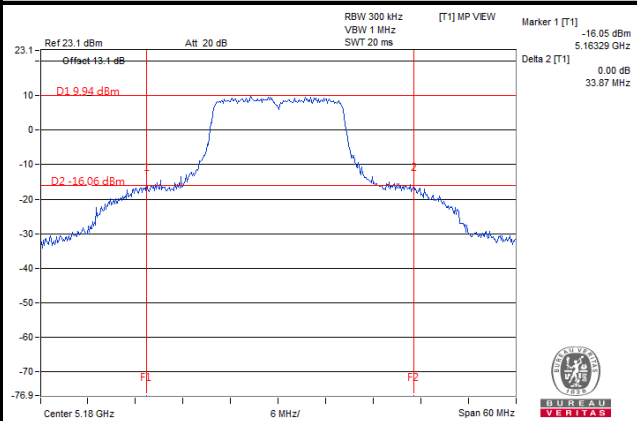

802.11n (HT20)

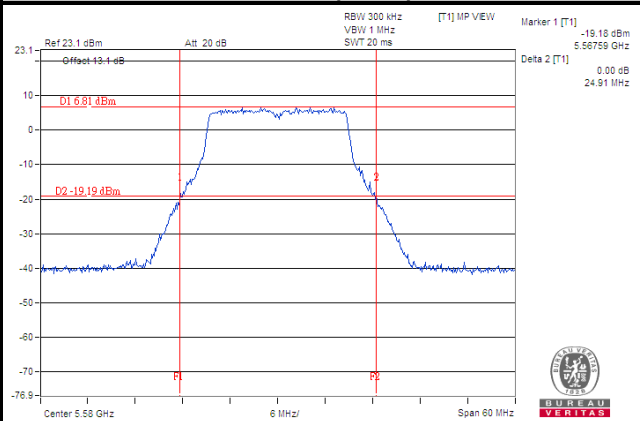

802.11n (HT40)

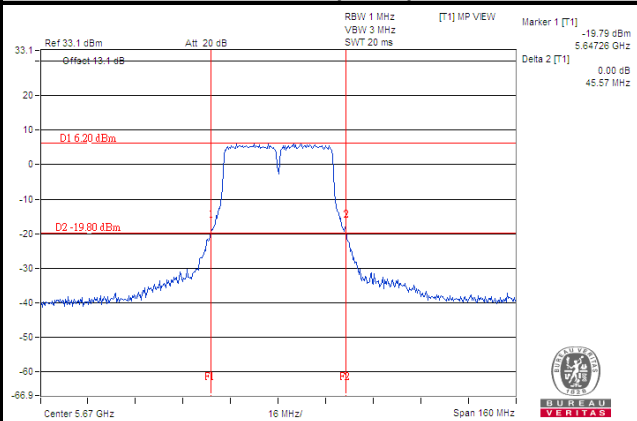

802.11ac (VHT80)

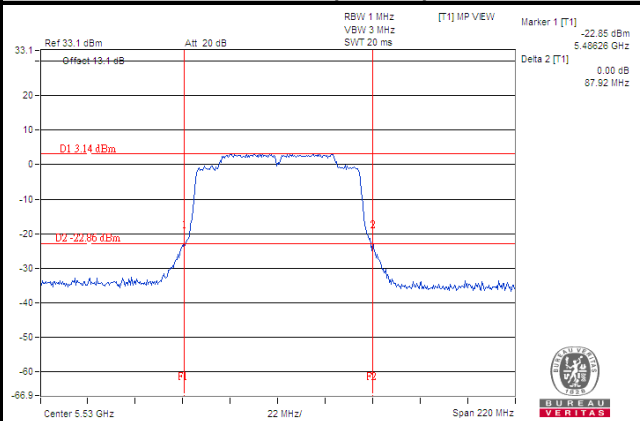

802.11ac (VHT160)

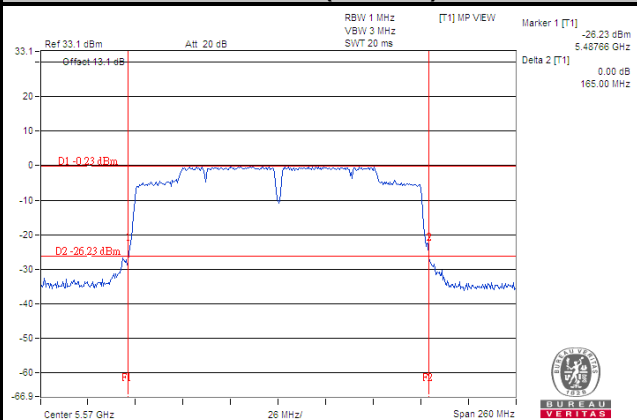

Spectrum Plot for Straddle Channels 802.11n (HT20)_ Ch 144 (5720 MHz)

Chain 0

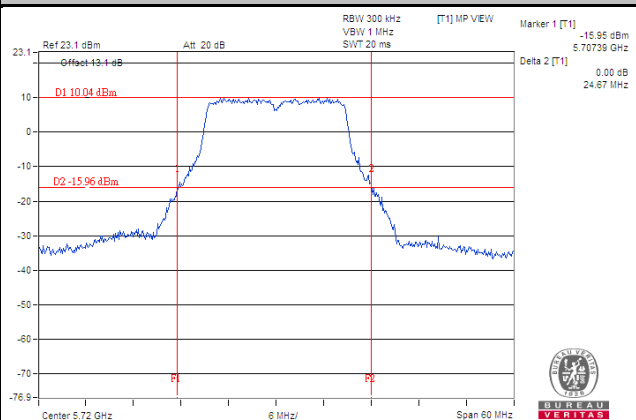

Chain 1

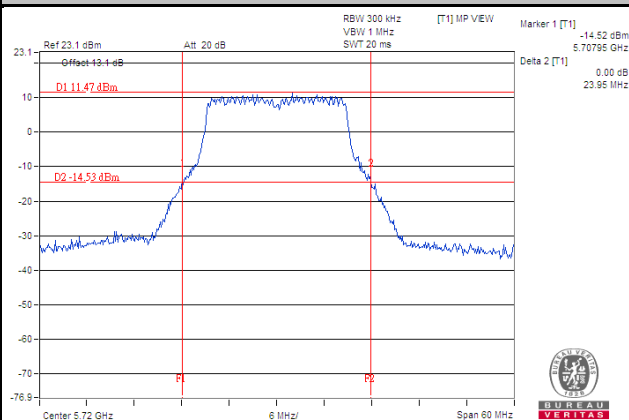

802.11n (HT40)_ Ch 142 (5710 MHz)

Chain 0

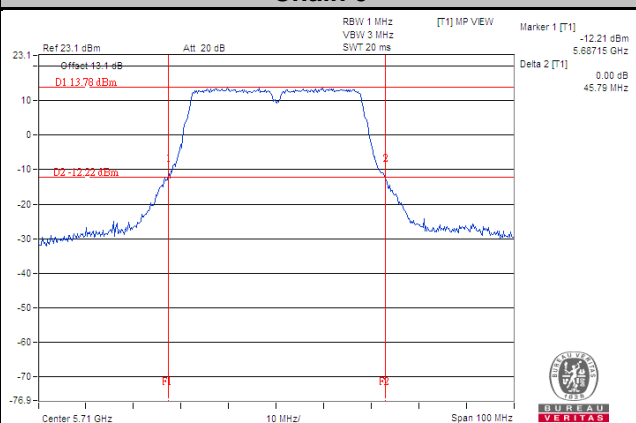

Chain 1

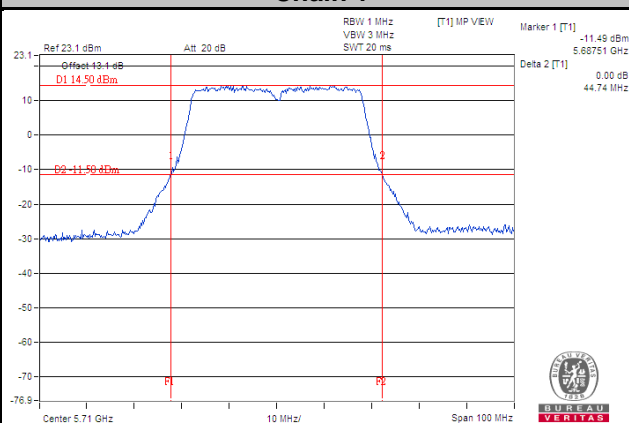

802.11ac (VHT80)_ Ch 138 (5690 MHz)

Chain 0

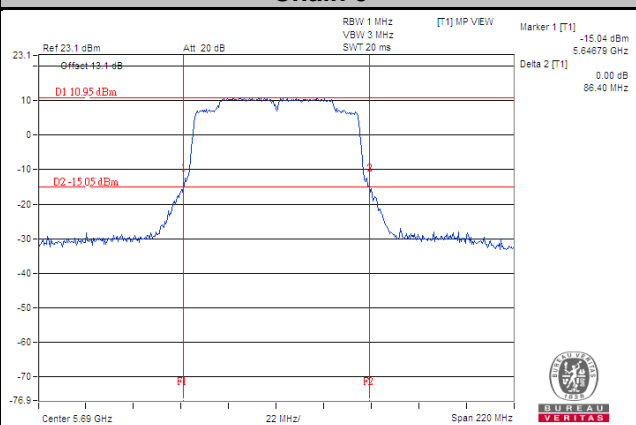

Chain 1

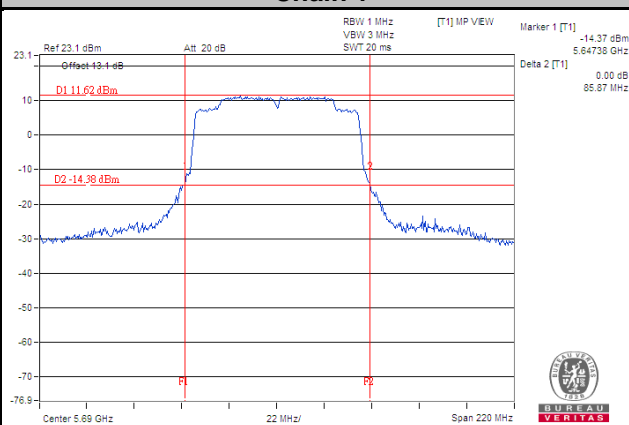

4.4 Occupied Bandwidth Measurement

4.4.1 Test Setup



4.4.2 Test Instruments

Refer to section 4.1.2 to get information of above instrument.

4.4.3 Test Procedure

The transmitter output was connected to the spectrum analyzer through an attenuator. The bandwidth of the fundamental frequency was measured by spectrum analyzer with resolution bandwidth in the range of 1 % to 5 % of the anticipated emission bandwidth, and a video bandwidth at least 3x the resolution bandwidth and set the detector to SAMPLE. The width of a frequency band such that, below the lower and above the upper frequency limits, the mean powers emitted are each equal to a specified percentage 0.5 % of the total mean power of a given emission.

4.4.4 Test Results

802.11a

Channel	Channel Frequency (MHz)	Occupied Bandwidth (MHz)
36	5180	17.28
40	5200	17.64
48	5240	17.40
52	5260	17.52
60	5300	17.40
64	5320	17.04
100	5500	17.04
116	5580	16.92
140	5700	17.04
149	5745	18.06
157	5785	17.46
165	5825	17.52

802.11n (HT20)

Channel	Channel Frequency (MHz)	Occupied Bandwidth (MHz)	
		Chain 0	Chain 1
36	5180	18.12	18.12
40	5200	18.12	18.12
48	5240	18.12	18.00
52	5260	18.00	18.00
60	5300	18.12	18.00
64	5320	18.24	18.00
100	5500	18.12	18.00
116	5580	18.12	17.88
140	5700	18.12	18.12
144	5720 (U-NII-2C)	14.00	14.00
144	5720 (U-NII-3)	3.76	3.76
149	5745	18.26	18.08
157	5785	18.17	18.08
165	5825	18.08	18.17

802.11n (HT40)

Channel	Channel Frequency (MHz)	Occupied Bandwidth (MHz)	
		Chain 0	Chain 1
38	5190	36.84	36.96
46	5230	36.96	36.72
54	5270	36.96	36.72
62	5310	36.96	36.72
102	5510	37.08	36.72
110	5550	36.96	36.84
134	5670	37.08	36.84
142	5710 (U-NII-2C)	33.48	33.36
142	5710 (U-NII-3)	3.48	3.36
151	5755	36.95	36.86
159	5795	36.95	36.78

802.11ac (VHT80)

Channel	Channel Frequency (MHz)	Occupied Bandwidth (MHz)	
		Chain 0	Chain 1
42	5210	75.60	75.60
58	5290	75.60	75.60
106	5530	75.36	75.36
122	5610	75.60	75.60
138	5690 (U-NII-2C)	72.68	72.68
138	5690 (U-NII-3)	2.68	2.44
155	5775	75.14	75.31

802.11ac (VHT160)

Channel	Channel Frequency (MHz)	Occupied Bandwidth (MHz)	
		Chain 0	Chain 1
50	5250	153.60	153.60
114	5570	153.60	153.60

Spectrum Plot of Worst Value

802.11a

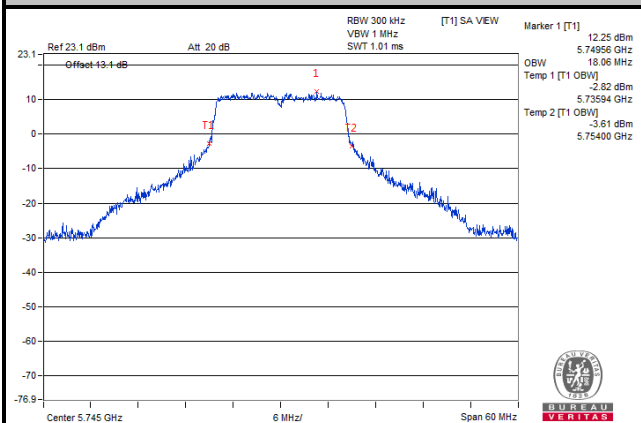

802.11n (HT20)

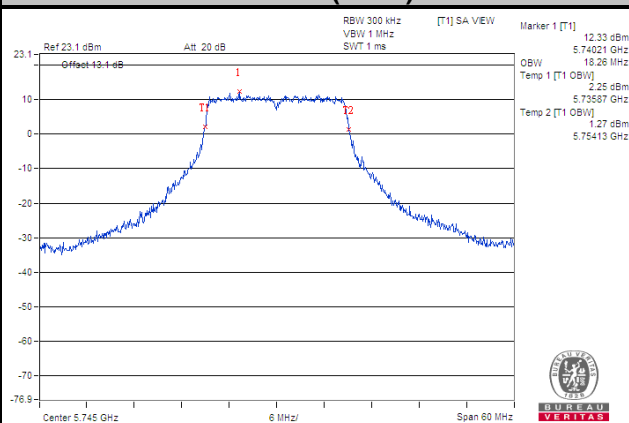

802.11n (HT40)

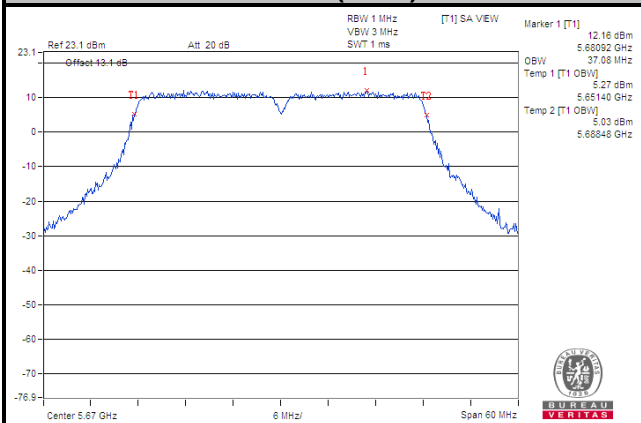

802.11ac (VHT80)

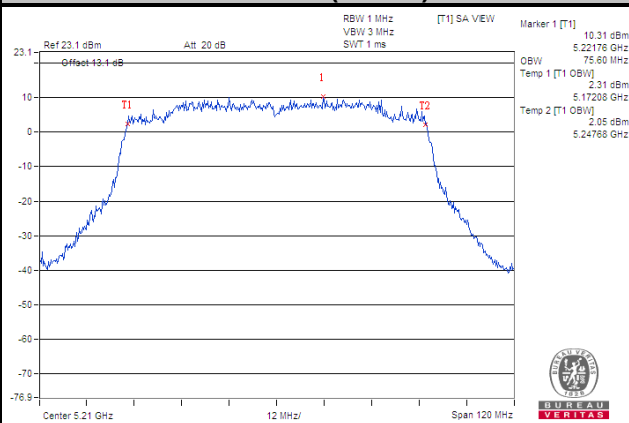

802.11ac (VHT160)

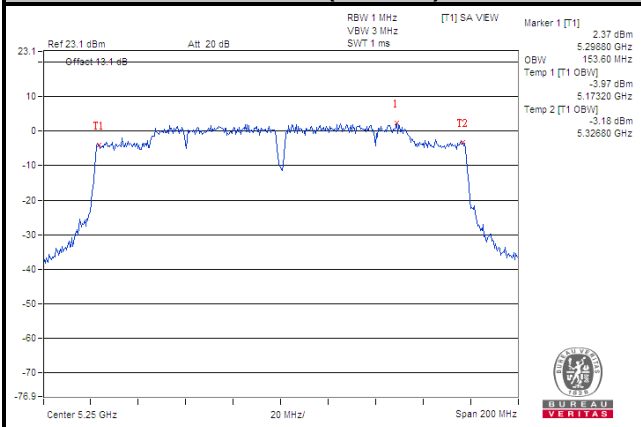

Chain 0

Spectrum Plot for Nearby DFS Band

802.11a

Ch 48 (5240 MHz)

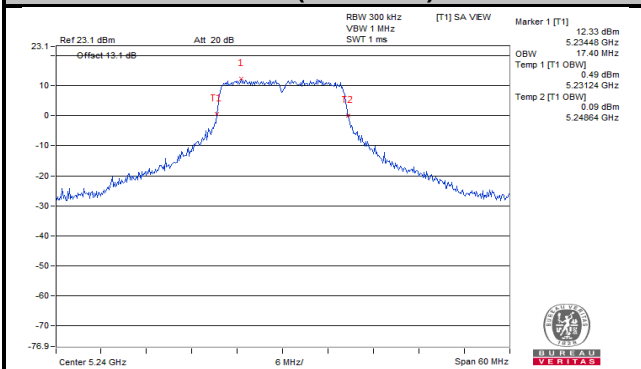

Ch 149 (5745 MHz)

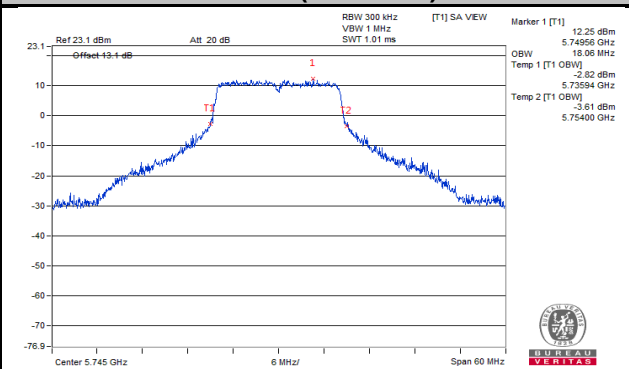

802.11n (HT20)

Ch 48 (5240 MHz)

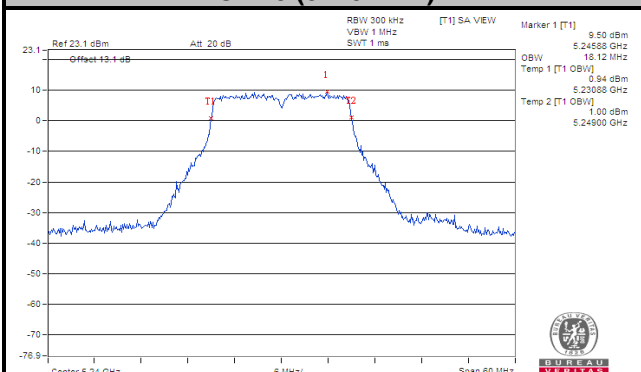

Ch 149 (5745 MHz)

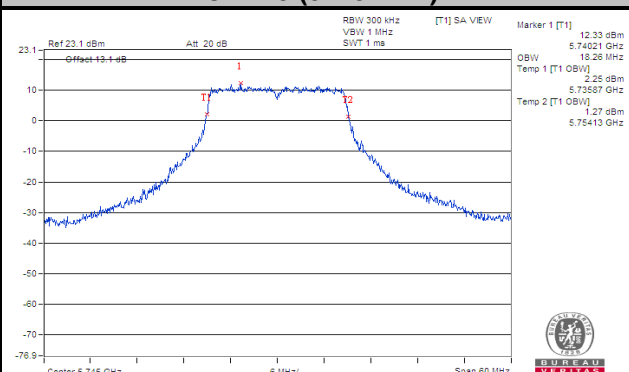

802.11n (HT40)

Ch 46 (5230 MHz)

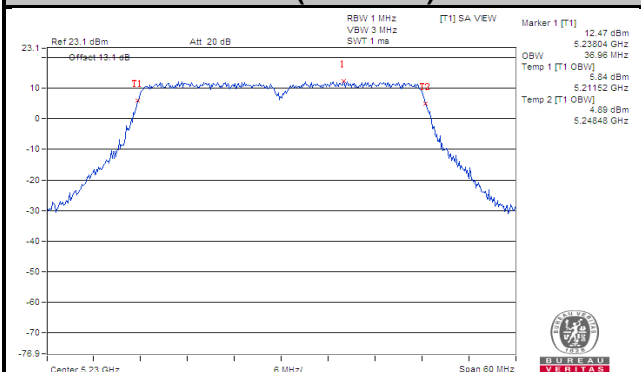

Ch 151 (5755 MHz)

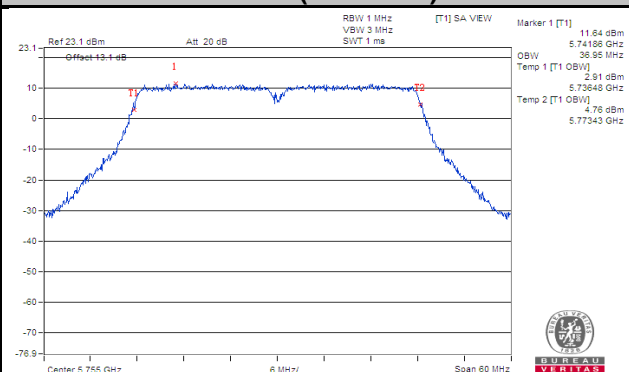

802.11ac (VHT80)

Ch 42 (5210 MHz)

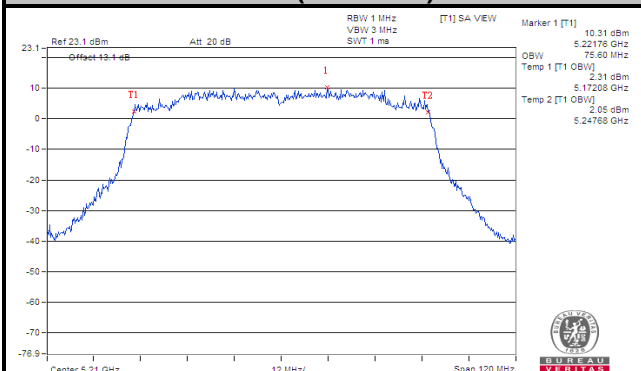

Ch 155 (5775 MHz)

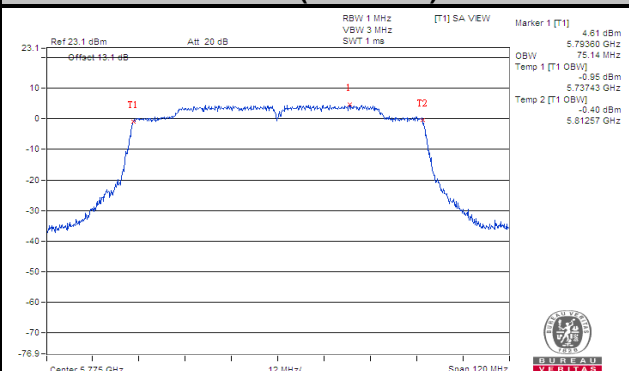

Chain 1

Spectrum Plot for Nearby DFS Band
802.11n (HT20)

Ch 48 (5240 MHz)

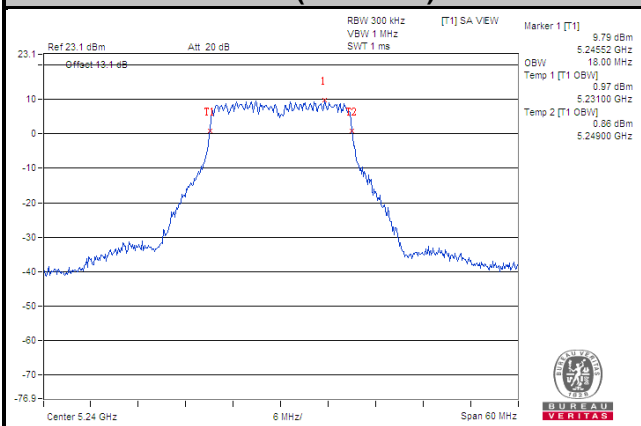

Ch 149 (5745 MHz)

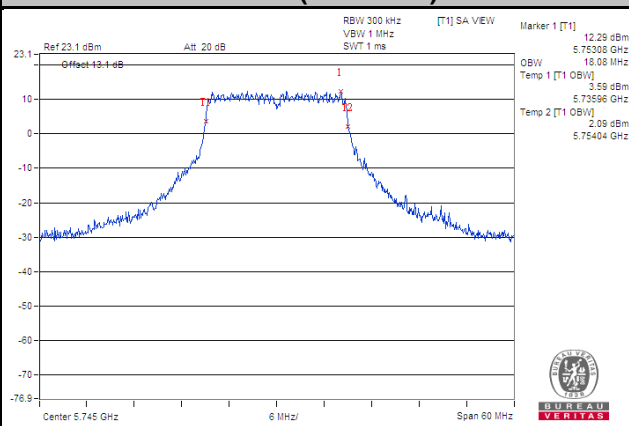

802.11n (HT40)

Ch 46 (5230 MHz)

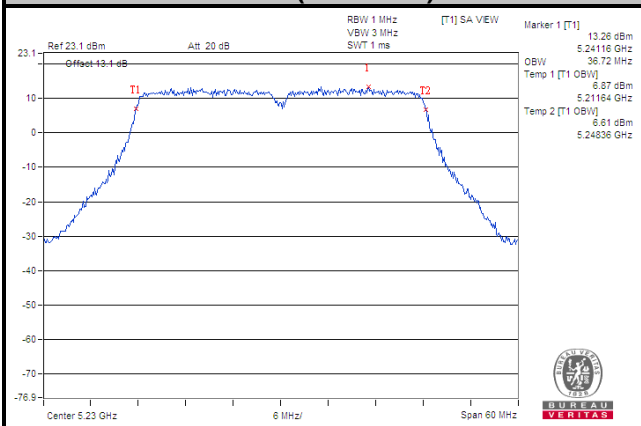

Ch 151 (5755 MHz)

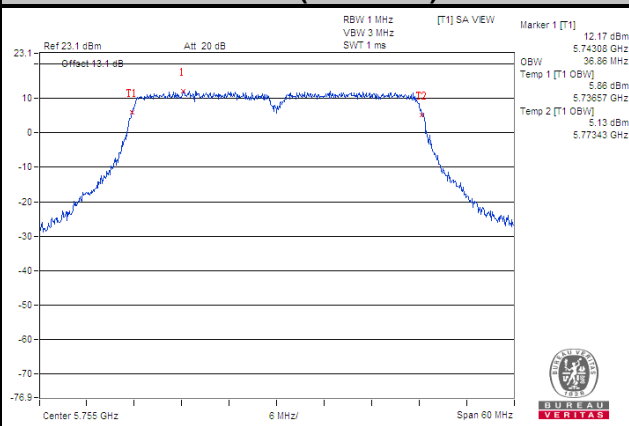

802.11ac (VHT80)

Ch 42 (5210 MHz)

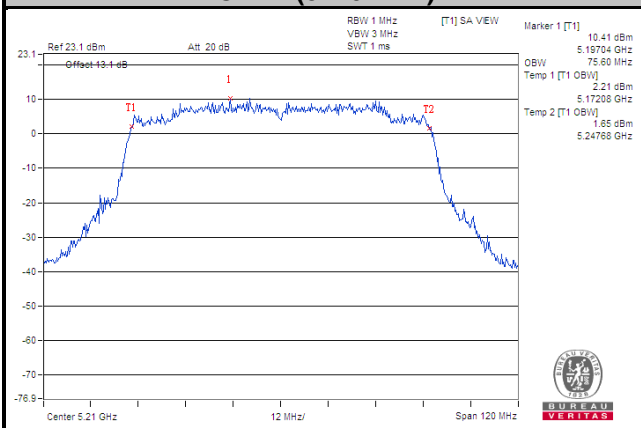

Ch 155 (5775 MHz)

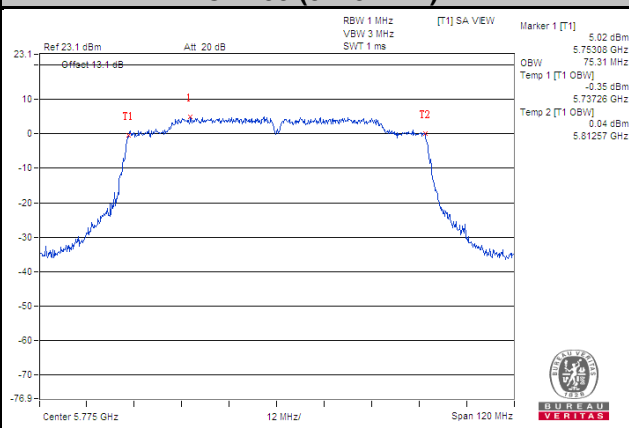

Spectrum Plot for Straddle Channels 802.11n (HT20)_ Ch 144 (5720 MHz)

Chain 0

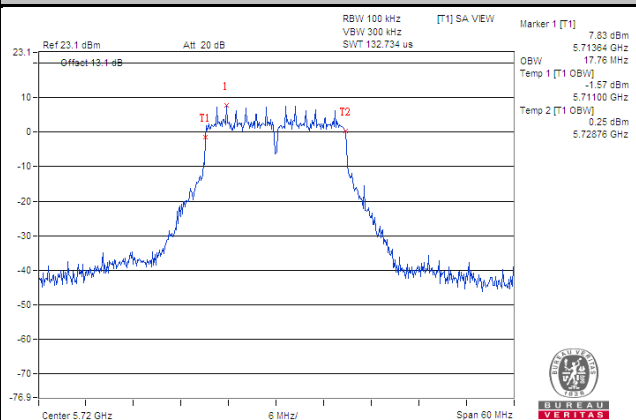

Chain 1

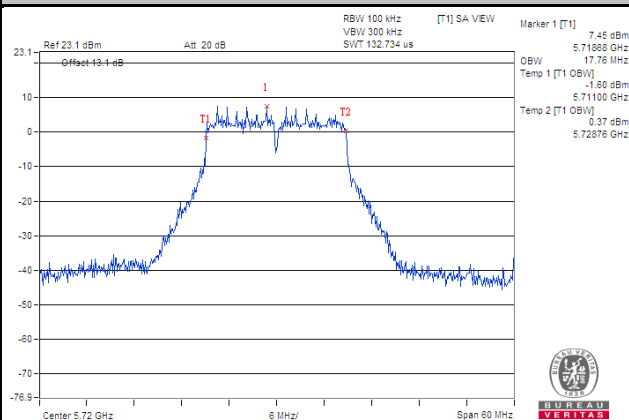

802.11n (HT40)_ Ch 142 (5710 MHz)

Chain 0

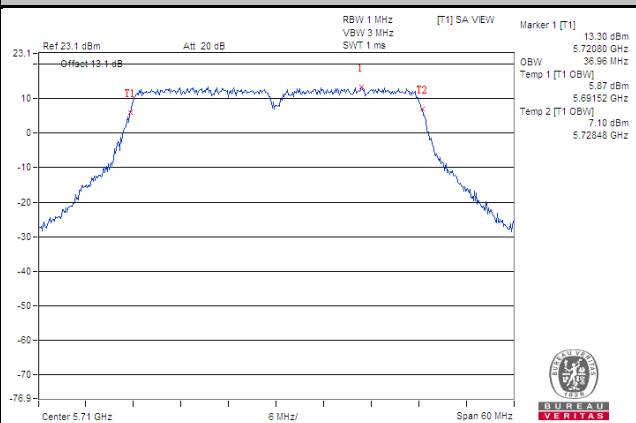

Chain 1

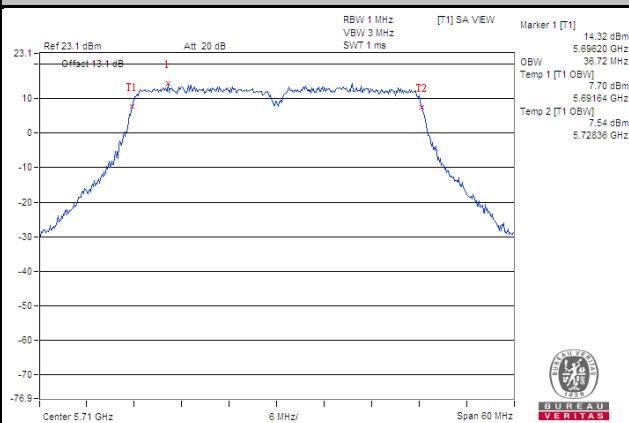

802.11ac (VHT80)_ Ch 138 (5690 MHz)

Chain 0

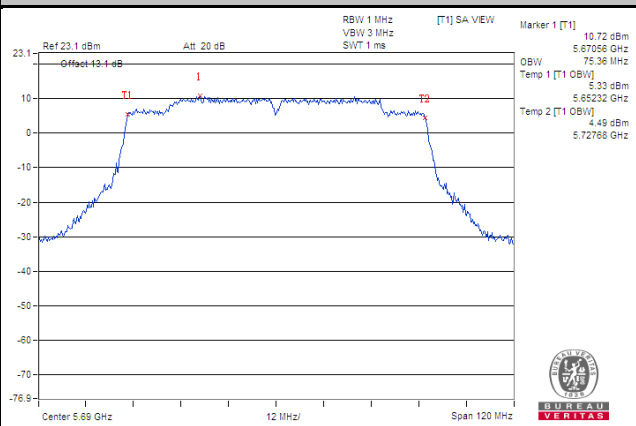

Chain 1

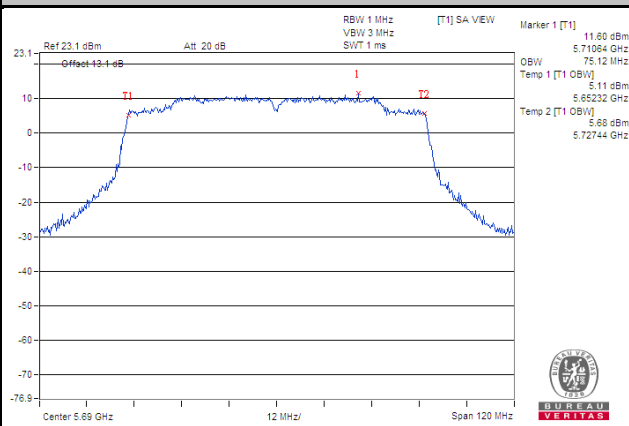

4.5 Peak Power Spectral Density Measurement

4.5.1 Limits of Peak Power Spectral Density Measurement

Operation Band	EUT Category		Limit
U-NII-1		Outdoor Access Point	17 dBm/MHz
		Fixed point-to-point Access Point	
		Indoor Access Point	
	√	Mobile and Portable client device	11 dBm/MHz
U-NII-2A		√	11 dBm/MHz
U-NII-2C		√	11 dBm/MHz
U-NII-3		√	30 dBm/500 kHz

4.5.2 Test Setup

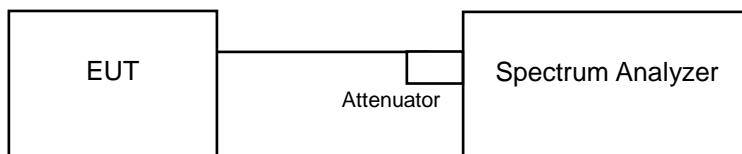

4.5.3 Test Instruments

Refer to section 4.1.3 to get information of above instrument.

4.5.4 Test Procedures

For U-NII-1, U-NII-2A, U-NII-2C band:

Using method SA-2 Duty cycle <98%

1. Set span to encompass the entire emission bandwidth (EBW) of the signal.
2. Set RBW = 1 MHz, Set VBW ≥ 3 RBW, Detector = RMS
3. Sweep time = auto, trigger set to “free run”.
4. Trace average at least 100 traces in power averaging mode.
5. Record the max value and add 10 log (1/duty cycle)

※ For U-NII-3: with duty cycle & Duty cycle <98 %

1. Set span to encompass the entire emission bandwidth (EBW) of the signal.
2. Set RBW = 300 kHz, Set VBW ≥ 1 RBW, Detector = RMS
3. Use the peak marker function to determine the maximum power level in any 300 kHz band segment within the fundamental EBW.
4. Scale the observed power level to an equivalent value in 500 kHz by adjusting (reducing) the measured power by a bandwidth correction factor (BWCF) where $BWCF = 10\log(500 \text{ kHz} / 300 \text{ kHz})$.
5. Sweep time = auto, trigger set to “free run”.
6. Trace average at least 100 traces in power averaging mode.
7. Record the max value and add 10 log (1/duty cycle)

4.5.5 Deviation from Test Standard

No deviation.

4.5.6 EUT Operating Conditions

The software provided by client to enable the EUT under transmission condition continuously at lowest, middle and highest channel frequencies individually.

4.5.7 Test Results

802.11a

Channel	Frequency (MHz)	PSD w/o Duty Factor (dBm/MHz)	Duty Factor (dB)	PSD with Duty Factor (dBm/MHz)	Maximum Limit (dBm/MHz)	Pass / Fail
36	5180	5.90	0.09	5.99	11	Pass
40	5200	8.66	0.09	8.75	11	Pass
48	5240	8.57	0.09	8.66	11	Pass
52	5260	8.57	0.09	8.66	11	Pass
60	5300	8.79	0.09	8.88	11	Pass
64	5320	4.76	0.09	4.85	11	Pass
100	5500	4.18	0.09	4.27	11	Pass
116	5580	4.16	0.09	4.25	11	Pass
140	5700	6.29	0.09	6.38	11	Pass

Note: Refer to section 3.3 for duty cycle spectrum plot.

802.11n (HT20)

Channel	Frequency (MHz)	PSD (dBm/MHz)		Duty Factor (dB)	Total PSD with Duty Factor (dBm/MHz)	Max. Limit (dBm/MHz)	Pass / Fail
		Chain 0	Chain 1				
36	5180	0.92	1.48	0.10	4.32	11	Pass
40	5200	3.40	3.29	0.10	6.46	11	Pass
48	5240	3.33	3.20	0.10	6.38	11	Pass
52	5260	3.44	3.27	0.10	6.47	11	Pass
60	5300	3.27	3.26	0.10	6.38	11	Pass
64	5320	1.50	1.30	0.10	4.51	11	Pass
100	5500	1.43	1.32	0.10	4.49	11	Pass
116	5580	0.98	1.59	0.10	4.41	11	Pass
140	5700	2.34	2.49	0.10	5.53	11	Pass
144	5720 (U-NII-2C)	3.84	3.86	0.10	6.96	11	Pass

Note:

- Method E) 2) a) of power density measurement of KDB 662911 is using for calculating total power density. Total power density is summing entire spectra across corresponding frequency bins on the various outputs by computer.
- For U-NII-1, U-NII-2A Band:**
Directional gain = $-1.67 \text{ dBi} + 10\log(2) = 1.34 \text{ dBi} < 6 \text{ dBi}$, so the limit no need to be reduced.
For U-NII-2C Band:
Directional gain = $-1.01 \text{ dBi} + 10\log(2) = 2 \text{ dBi} < 6 \text{ dBi}$, so the limit no need to be reduced.
- Refer to section 3.3 for duty cycle spectrum plot.

802.11n (HT40)

Channel	Frequency (MHz)	PSD (dBm/MHz)		Duty Factor (dB)	Total PSD with Duty Factor (dBm/MHz)	Max. Limit (dBm/MHz)	Pass / Fail
		Chain 0	Chain 1				
38	5190	-1.32	-1.07	0.20	2.02	11	Pass
46	5230	1.12	1.09	0.20	4.32	11	Pass
54	5270	1.50	1.46	0.20	4.69	11	Pass
62	5310	-3.02	-2.79	0.20	0.31	11	Pass
102	5510	-3.84	-4.00	0.20	-0.71	11	Pass
110	5550	-4.05	-3.90	0.20	-0.76	11	Pass
134	5670	0.89	0.51	0.20	3.91	11	Pass
142	5710 (U-NII-2C)	1.68	1.68	0.20	4.89	11	Pass

Note:

- Method E) 2) a) of power density measurement of KDB 662911 is using for calculating total power density. Total power density is summing entire spectra across corresponding frequency bins on the various outputs by computer.
- For U-NII-1, U-NII-2A Band:**
Directional gain = $-1.67 \text{ dBi} + 10\log(2) = 1.34 \text{ dBi} < 6 \text{ dBi}$, so the limit no need to be reduced.
For U-NII-2C Band:
Directional gain = $-1.01 \text{ dBi} + 10\log(2) = 2 \text{ dBi} < 6 \text{ dBi}$, so the limit no need to be reduced.
- Refer to section 3.3 for duty cycle spectrum plot.

802.11ac (VHT80)

Channel	Frequency (MHz)	PSD (dBm/MHz)		Duty Factor (dB)	Total PSD with Duty Factor (dBm/MHz)	Max. Limit (dBm/MHz)	Pass / Fail
		Chain 0	Chain 1				
42	5210	-4.65	-4.98	0.38	-1.42	11	Pass
58	5290	-7.99	-7.54	0.38	-4.37	11	Pass
106	5530	-8.00	-7.77	0.38	-4.49	11	Pass
122	5610	-1.79	-1.58	0.38	1.71	11	Pass
138	5690 (U-NII-2C)	0.00	-0.17	0.38	3.31	11	Pass

Note:

- Method E) 2) a) of power density measurement of KDB 662911 is using for calculating total power density. Total power density is summing entire spectra across corresponding frequency bins on the various outputs by computer.
- For U-NII-1, U-NII-2A Band:**
Directional gain = $-1.67 \text{ dBi} + 10\log(2) = 1.34 \text{ dBi} < 6 \text{ dBi}$, so the limit no need to be reduced.
For U-NII-2C Band:
Directional gain = $-1.01 \text{ dBi} + 10\log(2) = 2 \text{ dBi} < 6 \text{ dBi}$, so the limit no need to be reduced.
- Refer to section 3.3 for duty cycle spectrum plot.

802.11ac (VHT160)

Channel	Frequency (MHz)	PSD (dBm/MHz)		Duty Factor (dB)	Total PSD with Duty Factor (dBm/MHz)	Max. Limit (dBm/MHz)	Pass / Fail
		Chain 0	Chain 1				
50	5250	-8.66	-8.62	0.67	-4.69	11	Pass
114	5570	-11.11	-11.58	0.67	-7.39	11	Pass

Note:

- Method E) 2) a) of power density measurement of KDB 662911 is using for calculating total power density. Total power density is summing entire spectra across corresponding frequency bins on the various outputs by computer.
- For U-NII-1, U-NII-2A Band:**
Directional gain = $-1.67 \text{ dBi} + 10\log(2) = 1.34 \text{ dBi} < 6 \text{ dBi}$, so the limit no need to be reduced.
For U-NII-2C Band:
Directional gain = $-1.01 \text{ dBi} + 10\log(2) = 2 \text{ dBi} < 6 \text{ dBi}$, so the limit no need to be reduced.
- Refer to section 3.3 for duty cycle spectrum plot.

Spectrum Plot of Worst Value

802.11a

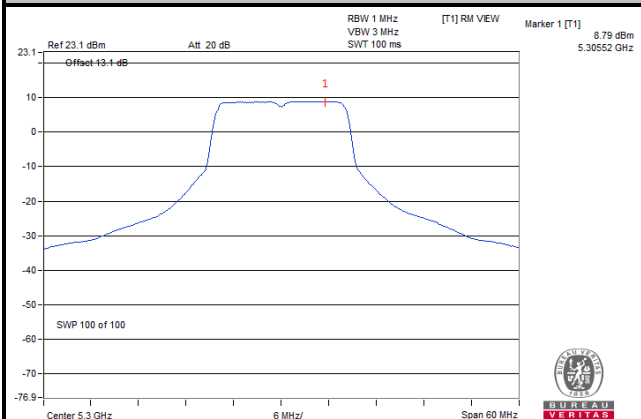

802.11n (HT20)

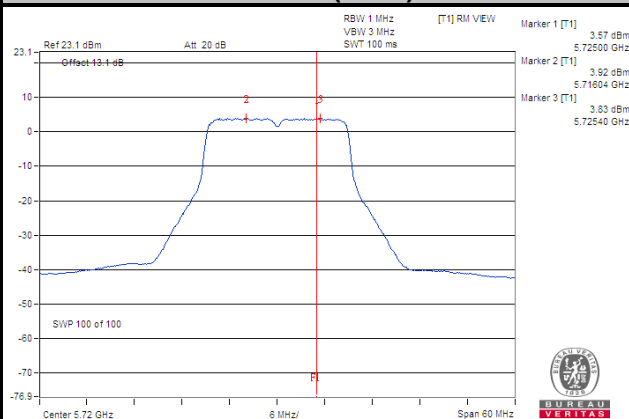

802.11n (HT40)

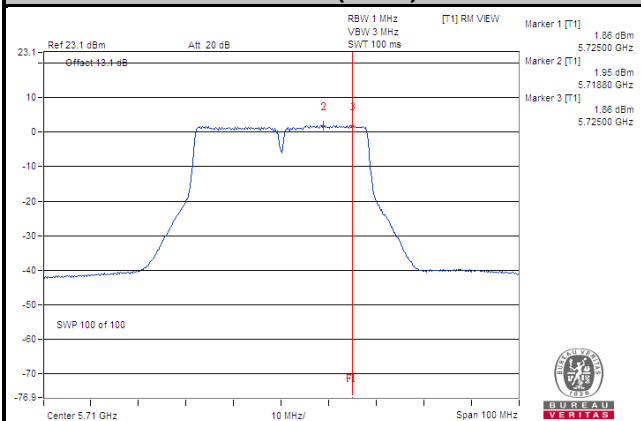

802.11ac (VHT80)

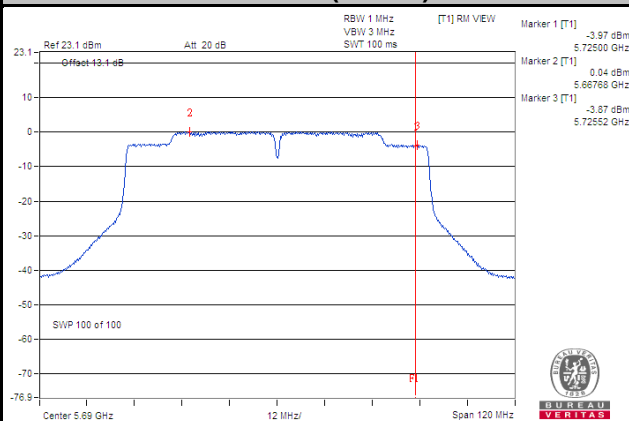

802.11ac (VHT160)

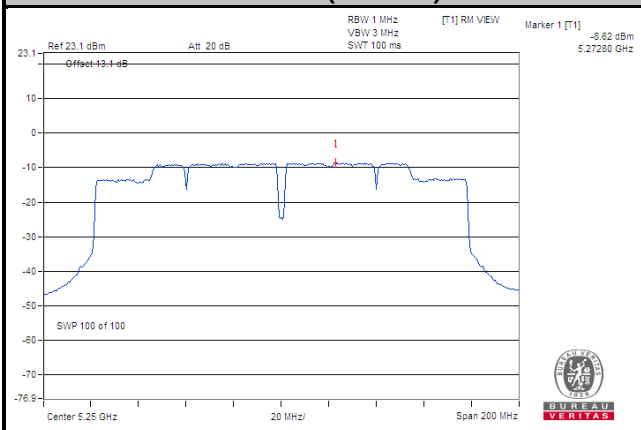

For U-NII-3 Band

802.11a

Channel	Frequency (MHz)	PSD w/o Duty Factor		Duty Factor (dB)	PSD with Duty Factor (dBm/500 kHz)	Limit (dBm/500 kHz)	Pass / Fail
		(dBm/300 kHz)	(dBm/500 kHz)				
144	5720 (U-NII-3)	3.49	5.71	0.09	5.80	30	Pass
149	5745	2.95	5.17	0.09	5.26	30	Pass
157	5785	3.19	5.41	0.09	5.50	30	Pass
165	5825	3.49	5.71	0.09	5.80	30	Pass

Note: Refer to section 3.3 for duty cycle spectrum plot.

802.11n (HT20)

TX Chain	Channel	Frequency (MHz)	PSD		10 log (N=2) dB	Duty Factor (dB)	Total PSD with Duty Factor (dBm/500 kHz)	Limit (dBm/500 kHz)	Pass / Fail
			(dBm/300 kHz)	(dBm/500 kHz)					
0	144	5720 (U-NII-3)	-4.63	-2.41	3.01	0.10	0.70	30	Pass
	149	5745	-2.53	-0.31	3.01	0.10	2.80	30	Pass
	157	5785	-2.48	-0.26	3.01	0.10	2.85	30	Pass
	165	5825	-2.56	-0.34	3.01	0.10	2.77	30	Pass
1	144	5720 (U-NII-3)	-4.46	-2.24	3.01	0.10	0.87	30	Pass
	149	5745	-2.08	0.14	3.01	0.10	3.25	30	Pass
	157	5785	-2.61	-0.39	3.01	0.10	2.72	30	Pass
	165	5825	-2.36	-0.14	3.01	0.10	2.97	30	Pass

Note:

1. Method E) 2) c) of power density measurement of KDB 662911 is using for calculating total power density.
2. Directional gain = $-1.04 \text{ dBi} + 10\log(2) = 1.97 \text{ dBi} < 6 \text{ dBi}$, so the limit no need to be reduced.
3. Refer to section 3.3 for duty cycle spectrum plot.

802.11n (HT40)

TX Chain	Channel	Frequency (MHz)	PSD		10 log (N=2) dB	Duty Factor (dB)	Total PSD with Duty Factor (dBm/500 kHz)	Limit (dBm/500 kHz)	Pass / Fail
			(dBm/300 kHz)	(dBm/500 kHz)					
0	142	5710 (U-NII-3)	-6.65	-4.43	3.01	0.20	-1.22	30	Pass
	151	5755	-8.58	-6.36	3.01	0.20	-3.15	30	Pass
	159	5795	-5.81	-3.59	3.01	0.20	-0.38	30	Pass
1	142	5710 (U-NII-3)	-6.81	-4.59	3.01	0.20	-1.38	30	Pass
	151	5755	-8.16	-5.94	3.01	0.20	-2.73	30	Pass
	159	5795	-5.42	-3.20	3.01	0.20	0.01	30	Pass

Note:

1. Method E) 2) c) of power density measurement of KDB 662911 is using for calculating total power density.
2. Directional gain = $-1.04 \text{ dBi} + 10\log(2) = 1.97 \text{ dBi} < 6 \text{ dBi}$, so the limit no need to be reduced.
3. Refer to section 3.3 for duty cycle spectrum plot.

802.11ac (VHT80)

TX Chain	Channel	Frequency (MHz)	PSD		10 log (N=2) dB	Duty Factor (dB)	Total PSD with Duty Factor (dBm/500 kHz)	Limit (dBm/500 kHz)	Pass / Fail
			(dBm/300 kHz)	(dBm/500 kHz)					
0	138	5690 (U-NII-3)	-13.01	-10.79	3.01	0.38	-7.40	30	Pass
	155	5775	-14.83	-12.61	3.01	0.38	-9.22	30	Pass
1	138	5690 (U-NII-3)	-12.82	-10.60	3.01	0.38	-7.21	30	Pass
	155	5775	-14.60	-12.38	3.01	0.38	-8.99	30	Pass

Note:

1. Method E) 2) c) of power density measurement of KDB 662911 is using for calculating total power density.
2. Directional gain = $-1.04 \text{ dBi} + 10\log(2) = 1.97 \text{ dBi} < 6 \text{ dBi}$, so the limit no need to be reduced.
3. Refer to section 3.3 for duty cycle spectrum plot.

Spectrum Plot of Worst Value

802.11a

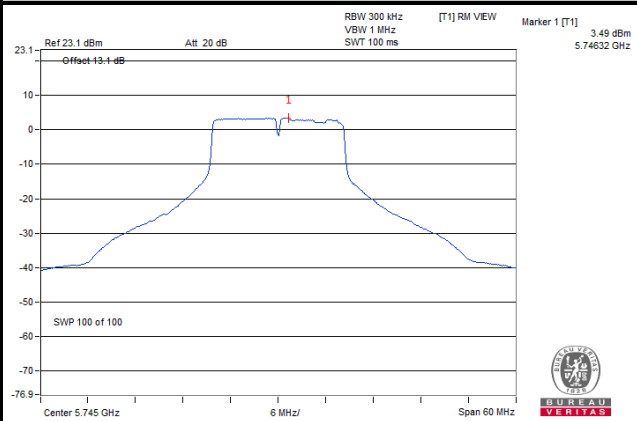

802.11n (HT20)

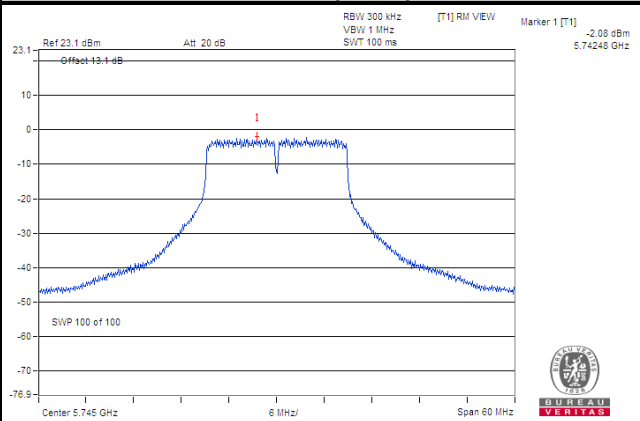

802.11n (HT40)

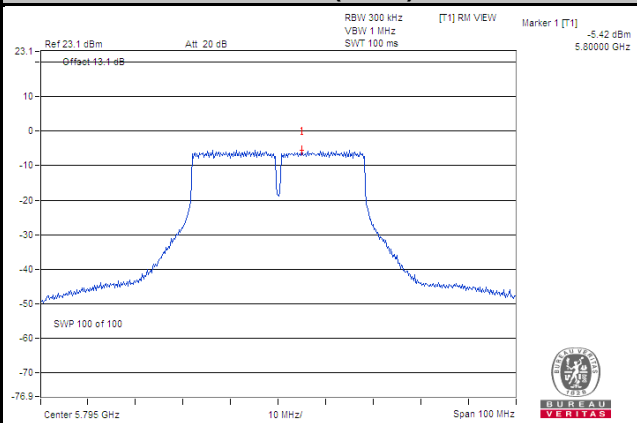

802.11ac (VHT80)

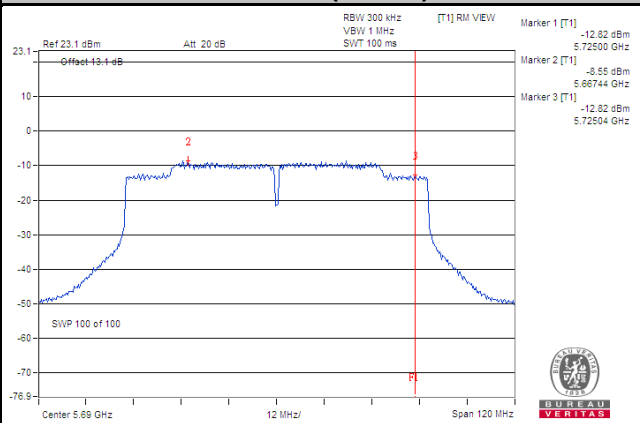

4.6 Frequency Stability

4.6.1 Limit of Frequency Stability Measurement

The frequency of the carrier signal shall be maintained within band of operation.

4.6.2 Test Setup

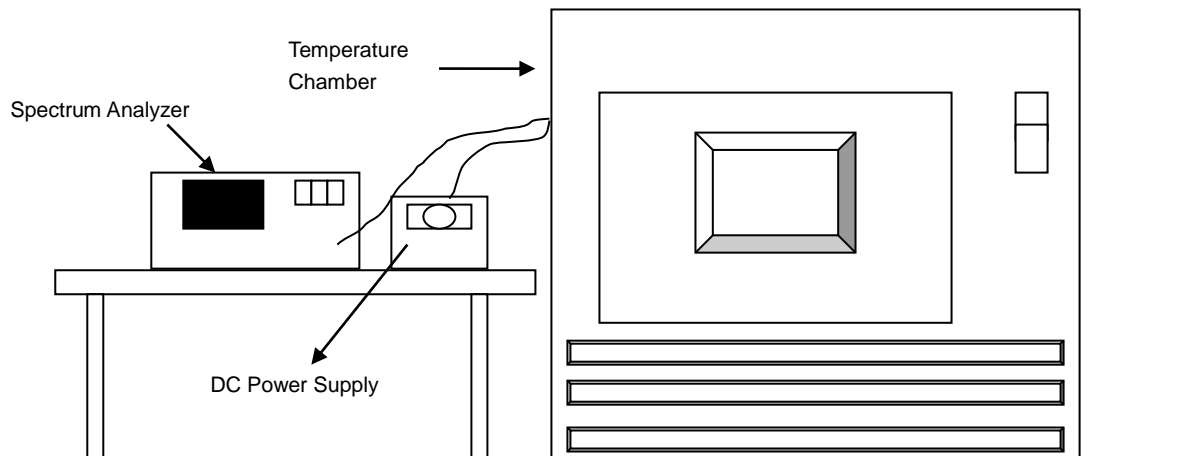

4.6.3 Test Instruments

Refer to section 4.1.3 to get information of above instrument.

4.6.4 Test Procedure

- The EUT was placed inside the environmental test chamber and powered by nominal DC voltage.
- Turn the EUT on and couple its output to a spectrum analyzer.
- Turn the EUT off and set the chamber to the highest temperature specified.
- Allow sufficient time (approximately 30 min) for the temperature of the chamber to stabilize, turn the EUT on and measure the operating frequency after 2, 5, and 10 Minutes.
- Repeat step (d) with the temperature chamber set to the next desired temperature until measurements down to the lowest specified temperature have been completed.
- The test chamber was allowed to stabilize at +20 degree C for a minimum of 30 Minutes. The supply voltage was then adjusted on the EUT from 85% to 115% and the frequency record.

4.6.5 Deviation from Test Standard

No deviation.

4.6.6 EUT Operating Condition

Set the EUT transmit at un-modulation mode to test frequency stability.

4.6.7 Test Results

Frequency Stability Versus Temp.									
Operating Frequency: 5180 MHz									
Temp. (°C)	Power Supply (Vdc)	0 Minute		2 Minute		5 Minute		10 Minute	
		Measured Frequency (MHz)	Frequency Drift (ppm)	Measured Frequency (MHz)	Frequency Drift (ppm)	Measured Frequency (MHz)	Frequency Drift (ppm)	Measured Frequency (MHz)	Frequency Drift (ppm)
40	11.52	5179.9728	PASS	5179.9746	PASS	5179.977	PASS	5179.9774	PASS
30	11.52	5179.9952	PASS	5179.9977	PASS	5179.999	PASS	5179.9953	PASS
20	11.52	5180.0062	PASS	5180.01	PASS	5180.0098	PASS	5180.0054	PASS
10	11.52	5179.9846	PASS	5179.9812	PASS	5179.9829	PASS	5179.9811	PASS
0	11.52	5179.9869	PASS	5179.986	PASS	5179.9831	PASS	5179.9829	PASS

Frequency Stability Versus Voltage									
Operating Frequency: 5180 MHz									
Temp. (°C)	Power Supply (Vdc)	0 Minute		2 Minute		5 Minute		10 Minute	
		Measured Frequency (MHz)	Frequency Drift (ppm)	Measured Frequency (MHz)	Frequency Drift (ppm)	Measured Frequency (MHz)	Frequency Drift (ppm)	Measured Frequency (MHz)	Frequency Drift (ppm)
20	13.248	5180.0057	PASS	5180.0099	PASS	5180.0097	PASS	5180.006	PASS
	11.52	5180.0062	PASS	5180.01	PASS	5180.0098	PASS	5180.0054	PASS
	9.792	5180.0071	PASS	5180.0105	PASS	5180.0101	PASS	5180.0059	PASS

4.7 6 dB Bandwidth Measurement

4.7.1 Limits of 6 dB Bandwidth Measurement

The minimum of 6 dB Bandwidth Measurement is 0.5 MHz.

4.7.2 Test Setup

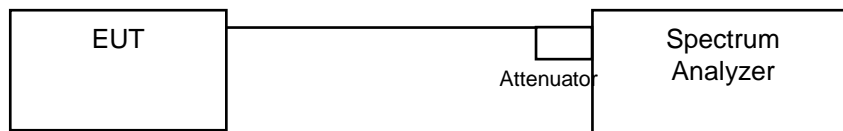

4.7.3 Test Instruments

Refer to section 4.1.3 to get information of above instrument.

4.7.4 Test Procedure

MEASUREMENT PROCEDURE REF

- Set resolution bandwidth (RBW) = 100 kHz
- Set the video bandwidth (VBW) $\geq 3 \times$ RBW, Detector = Peak.
- Trace mode = max hold.
- Sweep = auto couple.
- Measure the maximum width of the emission that is constrained by the frequencies associated with the two amplitude points (upper and lower) that are attenuated by 6 dB relative to the maximum level measured in the fundamental emission

4.7.5 Deviation from Test Standard

No deviation.

4.7.6 EUT Operating Condition

The software provided by client to enable the EUT under transmission condition continuously at lowest, middle and highest channel frequencies individually.

4.7.7 Test Results

802.11a

Channel	Frequency (MHz)	6 dB Bandwidth (MHz)	Minimum Limit (MHz)	Pass / Fail
149	5745	16.37	0.5	Pass
157	5785	16.36	0.5	Pass
165	5825	16.36	0.5	Pass

802.11n (HT20)

Channel	Frequency (MHz)	6 dB Bandwidth (MHz)		Minimum Limit (MHz)	Pass / Fail
		Chain 0	Chain 1		
144	5720 (U-NII-3)	3.81	3.80	0.5	Pass
149	5745	17.61	17.64	0.5	Pass
157	5785	17.64	17.64	0.5	Pass
165	5825	17.62	17.65	0.5	Pass

802.11n (HT40)

Channel	Frequency (MHz)	6 dB Bandwidth (MHz)		Minimum Limit (MHz)	Pass / Fail
		Chain 0	Chain 1		
142	5710 (U-NII-3)	3.22	3.22	0.5	Pass
151	5755	36.43	36.44	0.5	Pass
159	5795	36.40	36.41	0.5	Pass

802.11ac (VHT80)

Channel	Frequency (MHz)	6 dB Bandwidth (MHz)		Minimum Limit (MHz)	Pass / Fail
		Chain 0	Chain 1		
138	5690 (U-NII-3)	2.62	2.62	0.5	Pass
155	5775	75.29	75.26	0.5	Pass

Spectrum Plot of Worst Value

802.11a

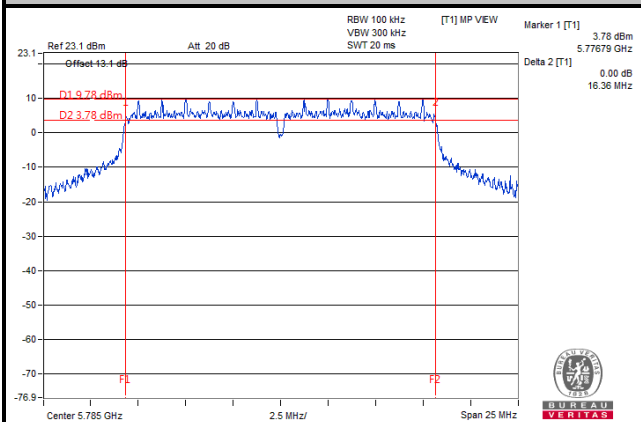

802.11n (HT20)

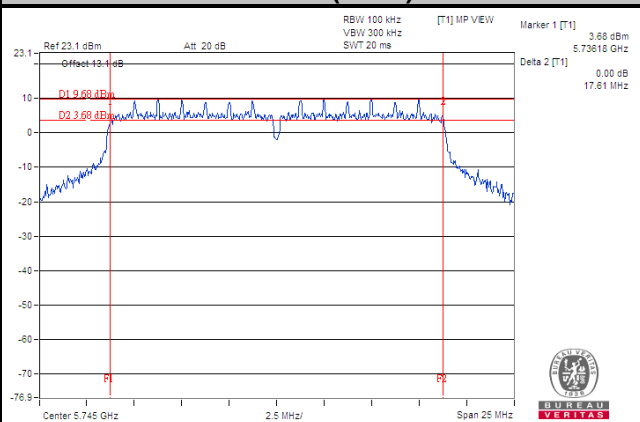

802.11n (HT40)

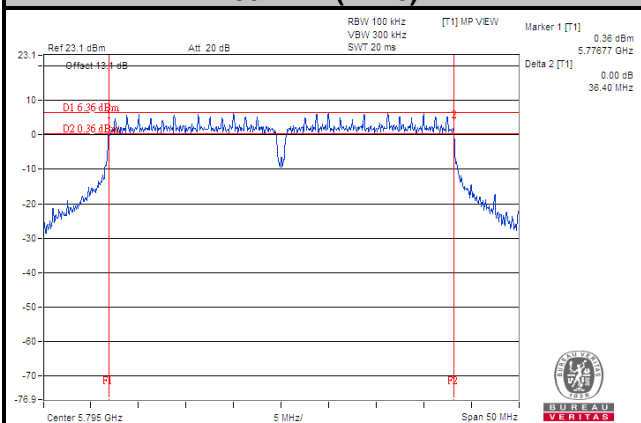

802.11ac (VHT80)

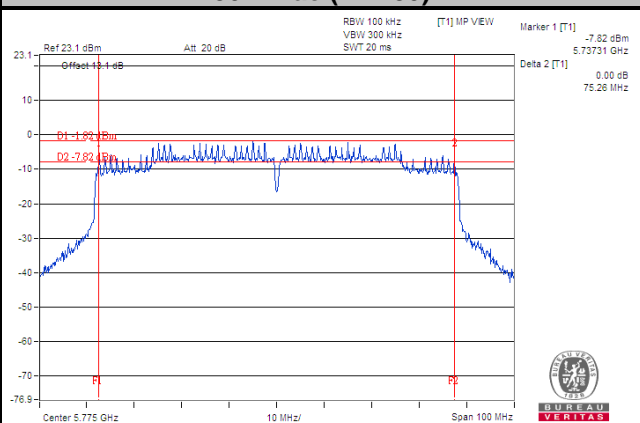

Spectrum Plot for Straddle Channels 802.11n (HT20)_ Ch 144 (5720 MHz)

Chain 0

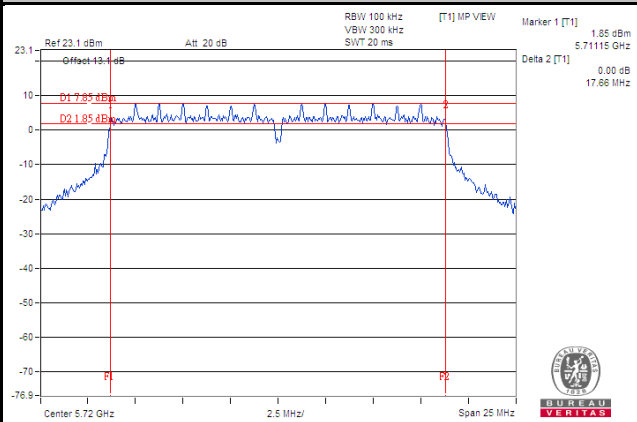

Chain 1

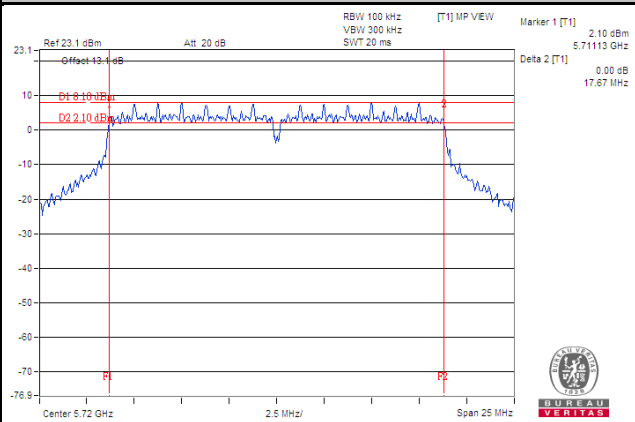

802.11n (HT40)_ Ch 142 (5710 MHz)

Chain 0

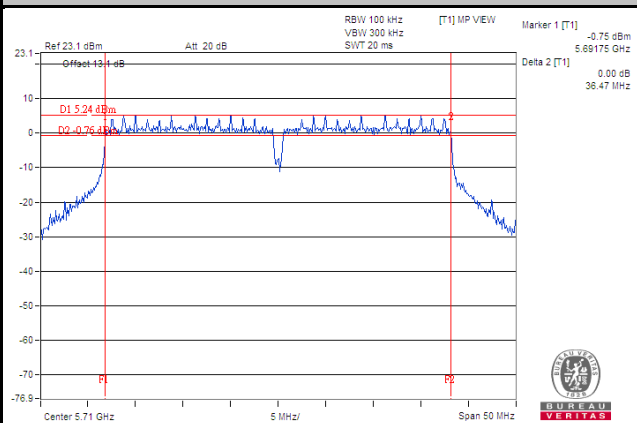

Chain 1

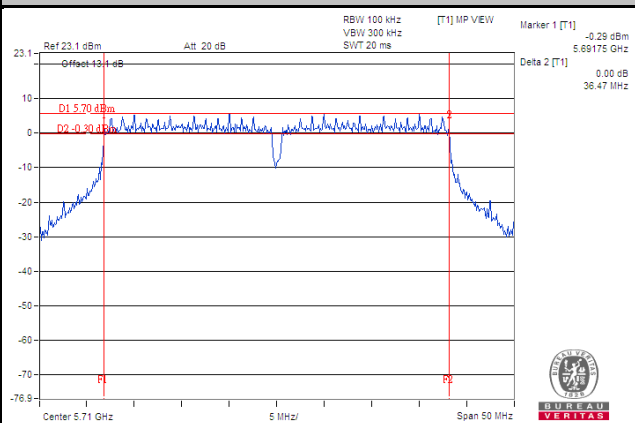

802.11ac (VHT80)_ Ch 138 (5690 MHz)

Chain 0

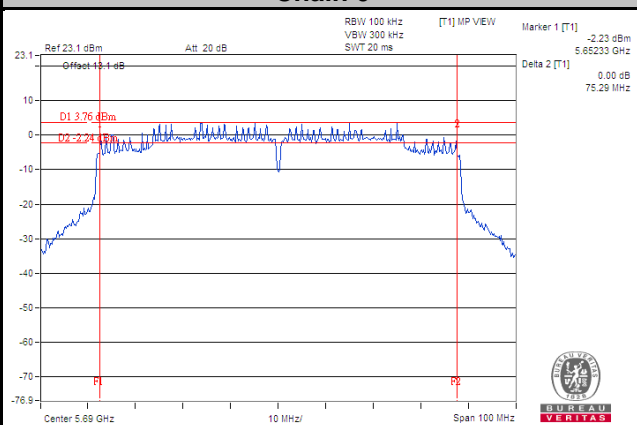

Chain 1

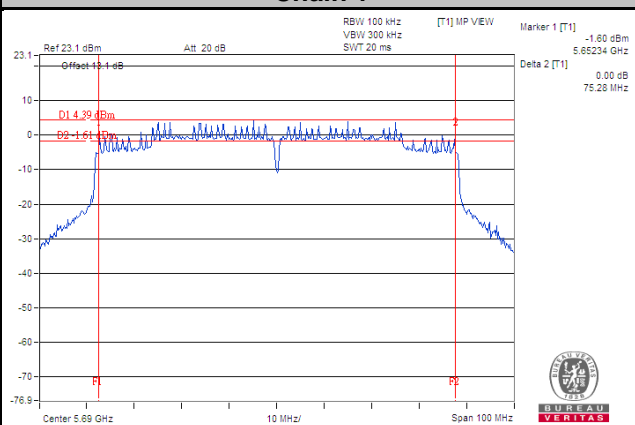

Note:

- Ch 144 (UNII-3 Band): The 6dB bandwidth above 5725MHz = Marker 1 + Delta 2 - 5725MHz
- Ch 142 (UNII-3 Band): The 6dB bandwidth above 5725MHz = Marker 1 + Delta 2 - 5725MHz
- Ch 138 (UNII-3 Band): The 6dB bandwidth above 5725MHz = Marker 1 + Delta 2 - 5725MHz

5 Pictures of Test Arrangements

Please refer to the attached file (Test Setup Photo).

Annex A- Radiated Out of Band Emission (OOBE) Measurement (For U-NII-3 band)

802.11a

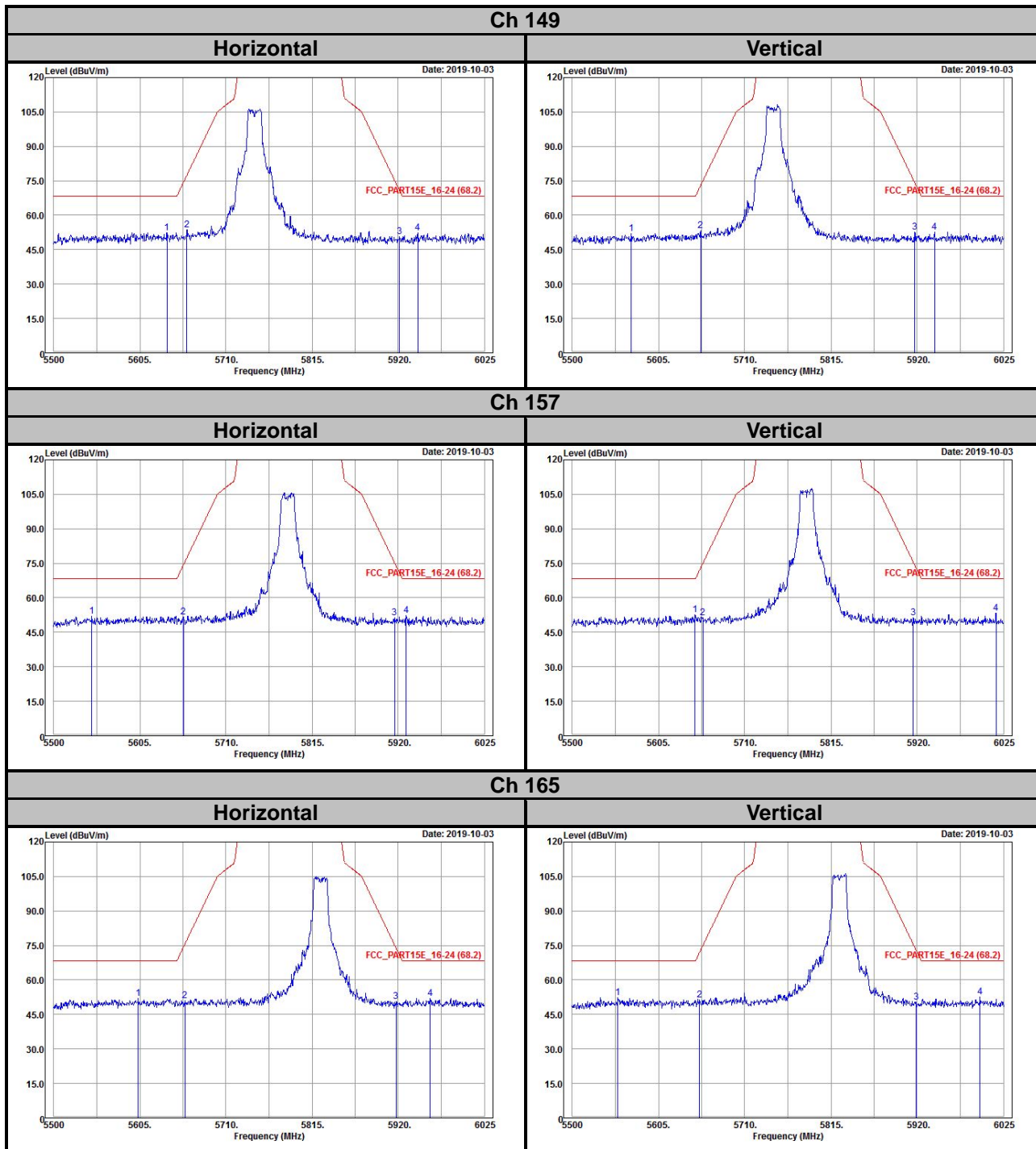

802.11n (HT20)

Ch 149

Horizontal

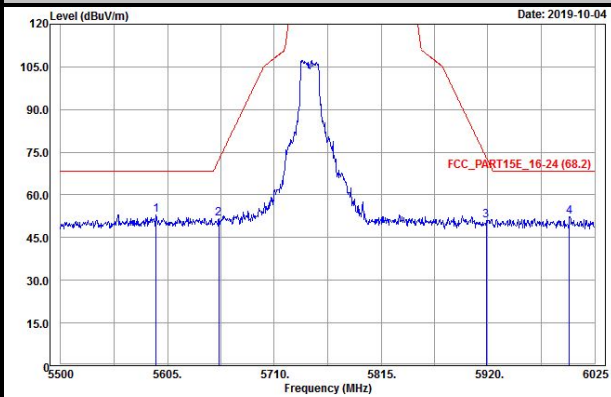

Vertical

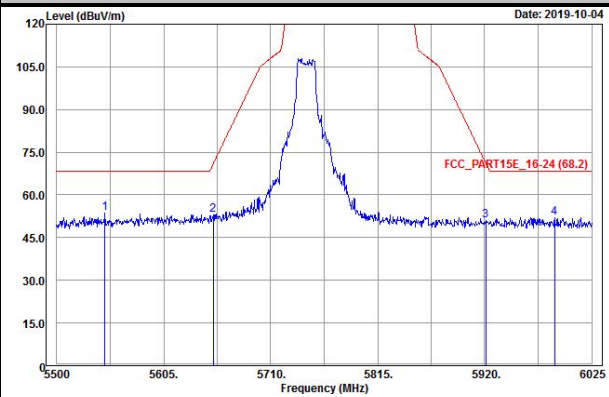

Ch 157

Horizontal

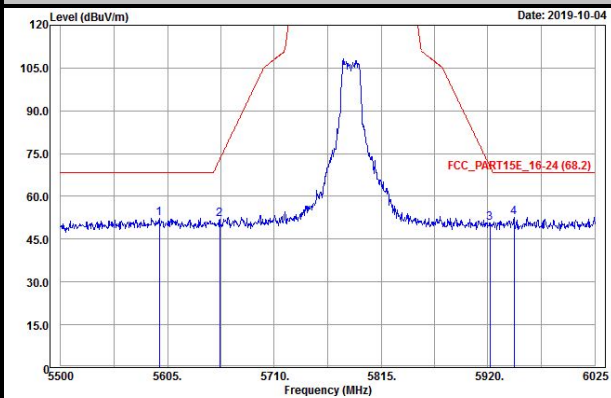

Vertical

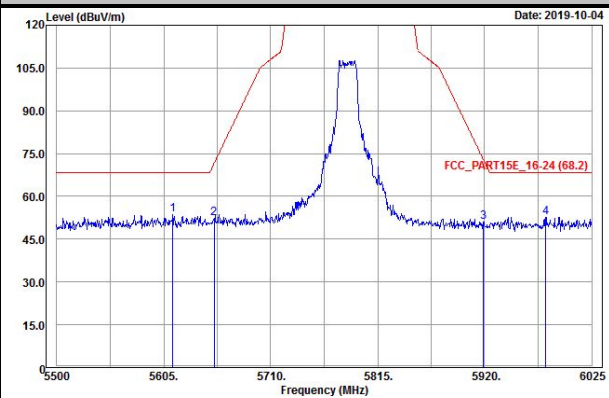

Ch 165

Horizontal

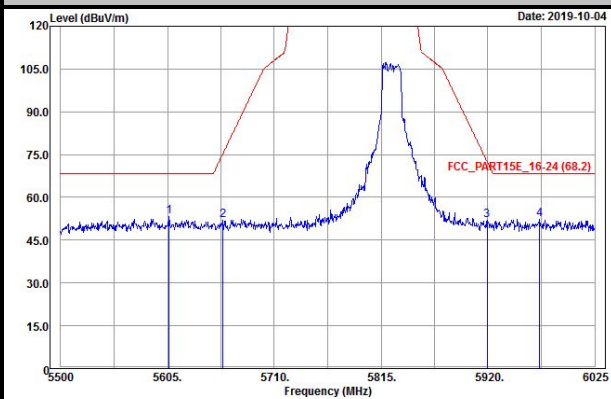

Vertical

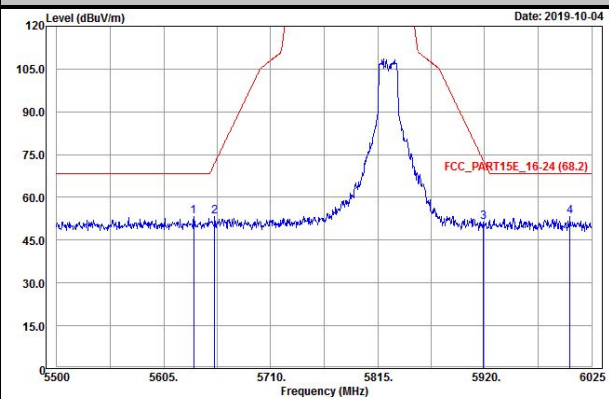

802.11n (HT40)

Ch 151

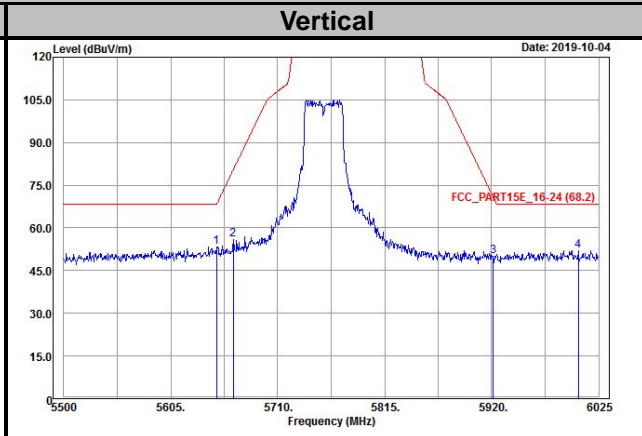
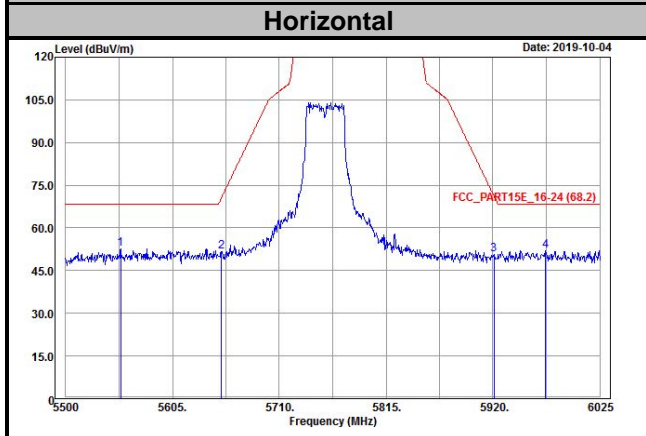

Ch 159

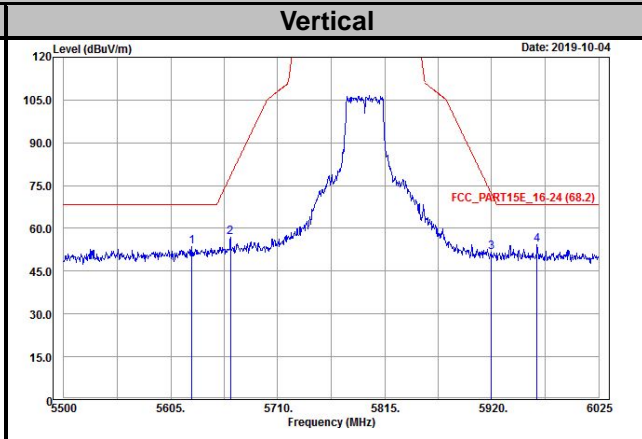
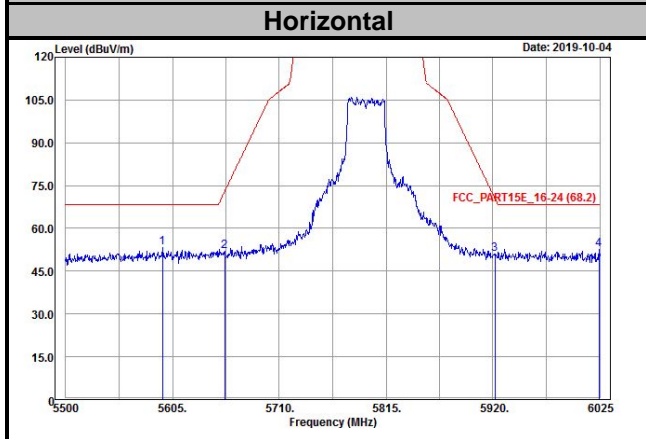

802.11ac (VHT80)

Ch 155

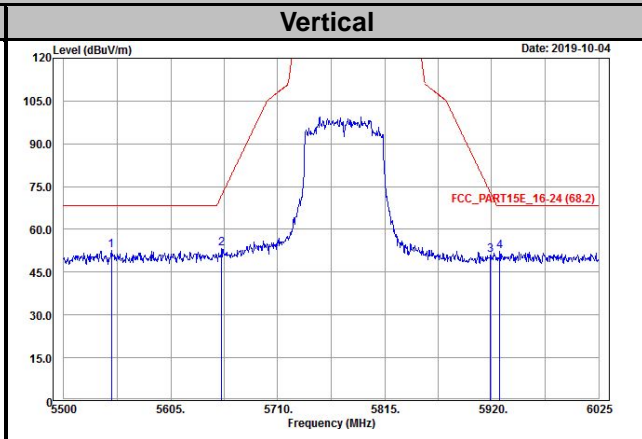
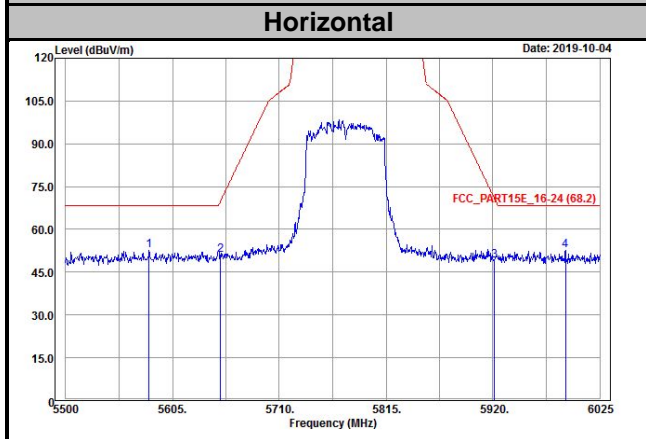

Appendix – Information of the Testing Laboratories

We, Bureau Veritas Consumer Products Services (H.K.) Ltd., Taoyuan Branch, were founded in 1988 to provide our best service in EMC, Radio, Telecom and Safety consultation. Our laboratories are FCC recognized accredited test firms and accredited according to ISO/IEC 17025.

If you have any comments, please feel free to contact us at the following:

Lin Kou EMC/RF Lab

Tel: 886-2-26052180

Fax: 886-2-26051924

Hsin Chu EMC/RF/Telecom Lab

Tel: 886-3-6668565

Fax: 886-3-6668323

Hwa Ya EMC/RF/Safety Lab

Tel: 886-3-3183232

Fax: 886-3-3270892

Email: service.adt@tw.bureauveritas.com

Web Site: www.bureauveritas-adt.com

The address and road map of all our labs can be found in our web site also.

--- END ---