

## FCC Test Report

**Report No.:** RF191021C06-2

**FCC ID:** I4L-LAVIELVAX200

**Test Model:** LN20006A

**Received Date:** Oct. 21, 2019

**Test Date:** Nov. 15 ~ Nov. 24, 2019

**Issued Date:** Nov. 28, 2019

**Applicant:** Micro-Star International Co., Ltd.

**Address:** No. 69, Lide St., Zhonghe Dist., 235 New Taipei City Taiwan

**Issued By:** Bureau Veritas Consumer Products Services (H.K.) Ltd., Taoyuan Branch  
Lin Kou Laboratories

**Lab Address:** No. 47-2, 14th Ling, Chia Pau Vil., Lin Kou Dist., New Taipei City, Taiwan

**Test Location (1):** No.19, Hwa Ya 2nd Rd., Wen Hwa Vil., Kwei Shan Dist., Taoyuan City  
33383, Taiwan

**Test Location (2):** B2F., No.215, Sec. 3, Beixin Rd., Xindian Dist., New Taipei City 231, Taiwan

**FCC Registration /** 788550 / TW0003

**Designation Number:** 427177 / TW0011



This report is for your exclusive use. Any copying or replication of this report to or for any other person or entity, or use of our name or trademark, is permitted only with our prior written permission. This report sets forth our findings solely with respect to the test samples identified herein. The results set forth in this report are not indicative or representative of the quality or characteristics of the lot from which a test sample was taken or any similar or identical product unless specifically and expressly noted. Our report includes all of the tests requested by you and the results thereof based upon the information that you provided to us. You have 60 days from date of issuance of this report to notify us of any material error or omission caused by our negligence, provided, however, that such notice shall be in writing and shall specifically address the issue you wish to raise. A failure to raise such issue within the prescribed time shall constitute your unqualified acceptance of the completeness of this report, the tests conducted and the correctness of the report contents. Unless specific mention, the uncertainty of measurement has been explicitly taken into account to declare the compliance or non-compliance to the specification. The report must not be used by the client to claim product certification, approval, or endorsement by TAF or any government agencies.

## Table of Contents

<b>Release Control Record</b> .....	<b>4</b>
<b>1 Certificate of Conformity</b> .....	<b>5</b>
<b>2 Summary of Test Results</b> .....	<b>6</b>
2.1 Measurement Uncertainty .....	6
2.2 Modification Record .....	6
<b>3 General Information</b> .....	<b>7</b>
3.1 General Description of EUT .....	7
3.2 Description of Test Modes .....	8
3.2.1 Test Mode Applicability and Tested Channel Detail .....	9
3.3 Duty Cycle of Test Signal .....	11
3.4 Description of Support Units .....	12
3.4.1 Configuration of System under Test .....	12
3.5 General Description of Applied Standards and references .....	12
<b>4 Test Types and Results</b> .....	<b>13</b>
4.1 Radiated Emission and Bandedge Measurement .....	13
4.1.1 Limits of Radiated Emission and Bandedge Measurement .....	13
4.1.2 Test Instruments .....	14
4.1.3 Test Procedures .....	15
4.1.4 Deviation from Test Standard .....	16
4.1.5 Test Set Up .....	16
4.1.6 EUT Operating Conditions .....	17
4.1.7 Test Results .....	18
4.2 Conducted Emission Measurement .....	50
4.2.1 Limits of Conducted Emission Measurement .....	50
4.2.2 Test Instruments .....	50
4.2.3 Test Procedures .....	51
4.2.4 Deviation from Test Standard .....	51
4.2.5 Test Setup .....	51
4.2.6 EUT Operating Conditions .....	51
4.2.7 Test Results .....	52
4.3 6 dB Bandwidth Measurement .....	54
4.3.1 Limits of 6 dB Bandwidth Measurement .....	54
4.3.2 Test Setup .....	54
4.3.3 Test Instruments .....	54
4.3.4 Test Procedure .....	54
4.3.5 Deviation from Test Standard .....	54
4.3.6 EUT Operating Conditions .....	54
4.3.7 Test Results .....	55
4.4 Occupied Bandwidth Measurement .....	58
4.4.1 Test Setup .....	58
4.4.2 Test Instruments .....	58
4.4.3 Test Procedure .....	58
4.4.4 Deviation from Test Standard .....	58
4.4.5 EUT Operating Conditions .....	58
4.4.6 Test Results .....	59
4.5 Conducted Output Power Measurement .....	62
4.5.1 Limits of Conducted Output Power Measurement .....	62
4.5.2 Test Setup .....	62
4.5.3 Test Instruments .....	62
4.5.4 Test Procedures .....	62
4.5.5 Deviation from Test Standard .....	62
4.5.6 EUT Operating Conditions .....	62
4.5.7 Test Results .....	63

4.6	Power Spectral Density Measurement .....	65
4.6.1	Limits of Power Spectral Density Measurement.....	65
4.6.2	Test Setup.....	65
4.6.3	Test Instruments .....	65
4.6.4	Test Procedure .....	65
4.6.5	Deviation from Test Standard .....	65
4.6.6	EUT Operating Condition .....	65
4.6.7	Test Results .....	66
4.7	Conducted Out of Band Emission Measurement .....	70
4.7.1	Limits of Conducted Out of Band Emission Measurement.....	70
4.7.2	Test Setup.....	70
4.7.3	Test Instruments .....	70
4.7.4	Test Procedure .....	70
4.7.5	Deviation from Test Standard .....	70
4.7.6	EUT Operating Condition .....	70
4.7.7	Test Results .....	70
<b>5</b>	<b>Pictures of Test Arrangements.....</b>	<b>91</b>
	<b>Appendix – Information of the Testing Laboratories .....</b>	<b>92</b>

### Release Control Record

Issue No.	Description	Date Issued
RF191021C06-2	Original Release	Nov. 28, 2019

## 1 Certificate of Conformity

**Product:** Notebook PC

**Brand:** NEC

**Test Model:** LN20006A

**Sample Status:** Mass product

**Applicant:** Micro-Star International Co., Ltd.

**Test Date:** Nov. 15 ~ Nov. 24, 2019

**Standards:** 47 CFR FCC Part 15, Subpart C (Section 15.247)  
ANSI C63.10:2013

The above equipment has been tested by **Bureau Veritas Consumer Products Services (H.K.) Ltd., Taoyuan Branch**, and found compliance with the requirement of the above standards. The test record, data evaluation & Equipment Under Test (EUT) configurations represented herein are true and accurate accounts of the measurements of the sample's RF characteristics under the conditions specified in this report.

**Prepared by :** Gina Liu, **Date:** Nov. 28, 2019  
Gina Liu / Specialist

**Approved by :** Dylan Chiou, **Date:** Nov. 28, 2019  
Dylan Chiou / Project Engineer

## 2 Summary of Test Results

47 CFR FCC Part 15, Subpart C (Section 15.247)			
FCC Clause	Test Item	Result	Remarks
15.207	AC Power Conducted Emission	Pass	Meet the requirement of limit. Minimum passing margin is -11.05 dB at 0.362 MHz.
15.205 / 15.209 / 15.247(d)	Radiated Emissions and Band Edge Measurement	Pass	Meet the requirement of limit. Minimum passing margin is -1 dB at 2486.28 MHz.
15.247(d)	Antenna Port Emission	Pass	Meet the requirement of limit.
15.247(a)(2)	6 dB Bandwidth	Pass	Meet the requirement of limit.
---	Occupied Bandwidth Measurement	Pass	Reference only
15.247(b)	Conducted power	Pass	Meet the requirement of limit.
15.247(e)	Power Spectral Density	Pass	Meet the requirement of limit.
15.203	Antenna Requirement	Pass	Antenna connector is i-pex(MHF) not a standard connector.

Note: Determining compliance based on the results of the compliance measurement, not taking into account measurement instrumentation uncertainty.

### 2.1 Measurement Uncertainty

Where relevant, the following measurement uncertainty levels have been estimated for tests performed on the EUT as specified in CISPR 16-4-2:

Measurement	Frequency	Expanded Uncertainty (k=2) (±)
Conducted Emissions at mains ports	150 kHz ~ 30 MHz	2.79 dB
Radiated Emissions up to 1 GHz	9 kHz ~ 30 MHz	3.04 dB
	30 MHz ~ 200 MHz	2.0153 dB
	200 MHz ~ 1000 MHz	2.0224 dB
Radiated Emissions above 1 GHz	1 GHz ~ 18 GHz	1.0121 dB
	18 GHz ~ 40 GHz	1.1508 dB

### 2.2 Modification Record

There were no modifications required for compliance.

### 3 General Information

#### 3.1 General Description of EUT

<b>Product</b>	Notebook PC
<b>Brand</b>	NEC
<b>Test Model</b>	LN20006A
<b>Status of EUT</b>	Mass product
<b>Power Supply Rating</b>	20.0 / 15.0 / 9.0 / 5.0 Vdc (adapter) 15.36 Vdc (Li-ion battery)
<b>Modulation Type</b>	CCK, DQPSK, DBPSK for DSSS 64QAM, 16QAM, QPSK, BPSK for OFDM 1024QAM for OFDMA
<b>Modulation Technology</b>	DSSS, OFDM, OFDMA
<b>Transfer Rate</b>	802.11b: 11.0 / 5.5 / 2.0 / 1.0 Mbps 802.11g: 54.0 / 48.0 / 36.0 / 24.0 / 18.0 / 12.0 / 9.0 / 6.0 Mbps 802.11n: up to 300.0 Mbps 802.11ax: up to 573.5 Mbps
<b>Operating Frequency</b>	2412 ~ 2472 MHz
<b>Number of Channel</b>	13 for 802.11b, 802.11g, 802.11n (HT20), 802.11ax (HE20) 9 for 802.11n (HT40), 802.11ax (HE40)
<b>Output Power</b>	184.312 mW
<b>Antenna Type</b>	PIFA antenna with -0.15 dBi gain
<b>Antenna Connector</b>	i-pex(MHF)
<b>Accessory Device</b>	Refer to Note as below
<b>Data Cable Supplied</b>	Refer to Note as below

Note:

- The EUT incorporates a MIMO function. Physically, the EUT provides two completed transmitters and two receivers.

Modulation Mode	Tx Function
802.11b	1TX
802.11g	1TX
802.11n (HT20)	2TX
802.11n (HT40)	2TX
802.11ax (HE20)	2TX
802.11ax (HE40)	2TX

- The EUT contains following accessory devices.

Product	Brand	Model	Description
Adapter	NEC	A19-095P1A	I/P: 100-240 Vac, 50-60 Hz, 1.6 A O/P: 20 Vdc, 4.75 A / 15 Vdc, 3 A / 9 Vdc, 3 A / 5 Vdc, 3 A
Battery	NEC	PC-VP-WP151	15.36 Vdc, 5235 mAh, Min.4711 mAh (72Wh)
WLAN Module	Intel	AX200NGW	--

- The above EUT information is declared by manufacturer and for more detailed features description, please refers to the manufacturer's specifications or user's manual.

### 3.2 Description of Test Modes

13 channels are provided for 802.11b, 802.11g, 802.11n (HT20) and 802.11ax (HE20):

Channel	Frequency (MHz)	Channel	Frequency (MHz)
1	2412	8	2447
2	2417	9	2452
3	2422	10	2457
4	2427	11	2462
5	2432	12	2467
6	2437	13	2472
7	2442		

9 channels are provided for 802.11n (HT40) and 802.11ax (HE40):

Channel	Frequency (MHz)	Channel	Frequency (MHz)
3	2422	8	2447
4	2427	9	2452
5	2432	10	2457
6	2437	11	2462
7	2442		



### 3.2.1 Test Mode Applicability and Tested Channel Detail

EUT Configure Mode	Applicable To				Description
	RE≥1G	RE<1G	PLC	APCM	
-	√	√	√	√	-

Where **RE≥1G**: Radiated Emission above 1 GHz      **RE<1G**: Radiated Emission below 1 GHz  
**PLC**: Power Line Conducted Emission      **APCM**: Antenna Port Conducted Measurement

**NOTE:** “-” means no effect.

#### **Radiated Emission Test (Above 1 GHz):**

- Pre-Scan has been conducted to determine the worst-case mode from all possible combinations between available modulations, data rates and antenna ports (if EUT with antenna diversity architecture).
- Following channel(s) was (were) selected for the final test as listed below.

EUT Configure Mode	Mode	Available Channel	Tested Channel	Modulation Technology	Modulation Type	Data Rate (Mbps)
-	802.11b	1 to 13	1, 6, 11, 12, 13	DSSS	DBPSK	1.0
-	802.11g	1 to 13	1, 6, 11, 12, 13	OFDM	BPSK	6.0
-	802.11n (HT20)	1 to 13	1, 6, 11, 12, 13	OFDM	BPSK	6.5
-	802.11n (HT40)	3 to 9	3, 6, 9, 10, 11	OFDM	BPSK	13.5
-	802.11ax (HE20)	1 to 13	1, 6, 11, 12, 13	OFDMA	BPSK	MCS0
-	802.11ax (HE40)	3 to 9	3, 6, 9, 10, 11	OFDMA	BPSK	MCS0

#### **Radiated Emission Test (Below 1 GHz):**

- Pre-Scan has been conducted to determine the worst-case mode from all possible combinations between available modulations, data rates and antenna ports (if EUT with antenna diversity architecture).
- Following channel(s) was (were) selected for the final test as listed below.

EUT Configure Mode	Mode	Available Channel	Tested Channel	Modulation Technology	Modulation Type	Data Rate (Mbps)
-	802.11ax (HE20)	1 to 13	13	OFDMA	BPSK	MCS0

#### **Power Line Conducted Emission Test:**

- Pre-Scan has been conducted to determine the worst-case mode from all possible combinations between available modulations, data rates and antenna ports (if EUT with antenna diversity architecture).
- Following channel(s) was (were) selected for the final test as listed below.

EUT Configure Mode	Mode	Available Channel	Tested Channel	Modulation Technology	Modulation Type	Data Rate (Mbps)
-	802.11ax (HE20)	1 to 13	13	OFDMA	BPSK	MCS0

### Bandedge Measurement:

- Pre-Scan has been conducted to determine the worst-case mode from all possible combinations between available modulations, data rates and antenna ports (if EUT with antenna diversity architecture).
- Following channel(s) was (were) selected for the final test as listed below.

EUT Configure Mode	Mode	Available Channel	Tested Channel	Modulation Technology	Modulation Type	Data Rate (Mbps)
-	802.11b	1 to 13	1, 11, 12, 13	DSSS	DBPSK	1.0
-	802.11g	1 to 13	1, 11, 12, 13	OFDM	BPSK	6.0
-	802.11n (HT20)	1 to 13	1, 11, 12, 13	OFDM	BPSK	6.5
-	802.11n (HT40)	3 to 9	3, 9, 10, 11	OFDM	BPSK	13.5
	802.11ax (HE20)	1 to 13	1, 11, 12, 13	OFDMA	BPSK	MCS0
	802.11ax (HE40)	3 to 9	3, 9, 10, 11	OFDMA	BPSK	MCS0

### Antenna Port Conducted Measurement:

- This item includes all test value of each mode, but only includes spectrum plot of worst value of each mode.
- Pre-Scan has been conducted to determine the worst-case mode from all possible combinations between available modulations, data rates and antenna ports (if EUT with antenna diversity architecture).
- Following channel(s) was (were) selected for the final test as listed below.

EUT Configure Mode	Mode	Available Channel	Tested Channel	Modulation Technology	Modulation Type	Data Rate (Mbps)
-	802.11b	1 to 13	1, 6, 11, 12, 13	DSSS	DBPSK	1.0
-	802.11g	1 to 13	1, 6, 11, 12, 13	OFDM	BPSK	6.0
-	802.11n (HT20)	1 to 13	1, 6, 11, 12, 13	OFDM	BPSK	6.5
-	802.11n (HT40)	3 to 9	3, 6, 9, 10, 11	OFDM	BPSK	13.5
	802.11ax (HE20)	1 to 13	1, 6, 11, 12, 13	OFDMA	BPSK	MCS0
	802.11ax (HE40)	3 to 9	3, 6, 9, 10, 11	OFDMA	BPSK	MCS0

### Test Condition:

Applicable To	Environmental Conditions	Input Power	Tested by
RE $\geq$ 1G	25 deg. C, 65 % RH	120 Vac, 60 Hz	Charles Hsiao, Harry Hsueh
RE<1G	25 deg. C, 65 % RH	120 Vac, 60 Hz	Karl Lee
PLC	25 deg. C, 65 % RH	120 Vac, 60 Hz	Jisyong Wang
APCM	25 deg. C, 65 % RH	15.36 Vdc	Gavin Wu

### 3.3 Duty Cycle of Test Signal

**802.11b:** Duty cycle of test signal is  $\geq 98\%$ , duty factor is not required.

**802.11g:** Duty cycle =  $2.085/2.132 = 0.978$ , Duty factor =  $10 * \log(1/0.978) = 0.10$

**802.11n (HT20):** Duty cycle of test signal is  $\geq 98\%$ , duty factor is not required.

**802.11n (HT40):** Duty cycle of test signal is  $\geq 98\%$ , duty factor is not required.

**802.11ax (HE20):** Duty cycle of test signal is  $\geq 98\%$ , duty factor is not required.

**802.11ax (HE40):** Duty cycle of test signal is  $\geq 98\%$ , duty factor is not required.



### 3.4 Description of Support Units

The EUT has been tested as an independent unit together with other necessary accessories or support units.

#### 3.4.1 Configuration of System under Test

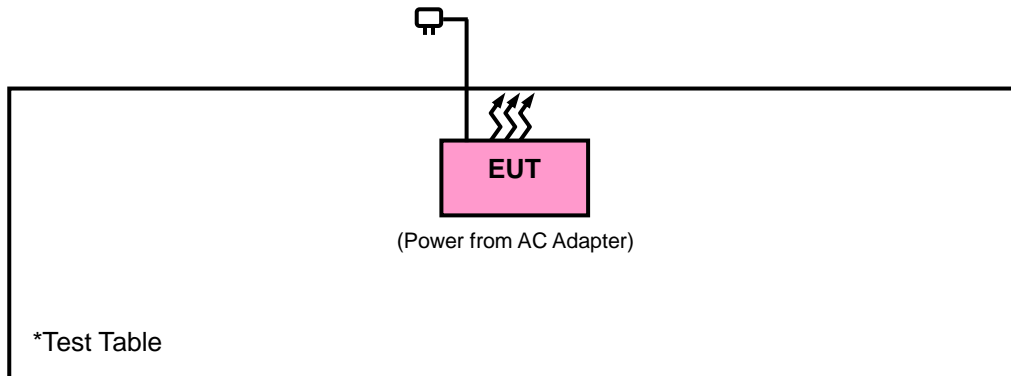

### 3.5 General Description of Applied Standards and references

The EUT is a RF Product. According to the specifications of the manufacturer, it must comply with the requirements of the following standards and references:

#### **FCC Part 15, Subpart C (15.247)**

ANSI C63.10-2013

All test items have been performed and recorded as per the above standards.

#### **References Test Guidance :**

**KDB 558074 D01 Meas Guidance v05r02**

**KDB 662911 D01 Multiple Transmitter Output v02r01**

All test items have been performed as a reference to the above KDB test guidance.

## 4 Test Types and Results

### 4.1 Radiated Emission and Bandedge Measurement

#### 4.1.1 Limits of Radiated Emission and Bandedge Measurement

Radiated emissions which fall in the restricted bands must comply with the radiated emission limits specified as below table. Other emissions shall be at least 20 dB below the highest level of the desired power:

Frequencies (MHz)	Field Strength (microvolts/meter)	Measurement Distance (meters)
0.009 ~ 0.490	2400/F (kHz)	300
0.490 ~ 1.705	24000/F (kHz)	30
1.705 ~ 30.0	30	30
30 ~ 88	100	3
88 ~ 216	150	3
216 ~ 960	200	3
Above 960	500	3

**NOTE:**

1. The lower limit shall apply at the transition frequencies.
2. Emission level (dBuV/m) = 20 log Emission level (uV/m).
3. For frequencies above 1000 MHz, the field strength limits are based on average detector, however, the peak field strength of any emission shall not exceed the maximum permitted average limits, specified above by more than 20 dB under any condition of modulation.

## 4.1.2 Test Instruments

Description & Manufacturer	Model No.	Serial No.	Date of Calibration	Due Date of Calibration
Test Receiver Agilent Technologies	N9038A	MY52260177	Aug. 26, 2019	Aug. 25, 2020
Spectrum Analyzer ROHDE & SCHWARZ	FSU43	101261	Apr. 15, 2019	Apr. 14, 2020
Spectrum Analyzer ROHDE & SCHWARZ	FSW26	102023	Oct. 08, 2019	Oct. 07, 2020
BILOG Antenna SCHWARZBECK	VULB 9168	9168-616	Nov. 27, 2018	Nov. 26, 2019
HORN Antenna ETS-Lindgren	3117	00143293	Nov. 25, 2018	Nov. 24, 2019
HORN Antenna SCHWARZBECK	BBHA 9170	9170-480	Nov. 25, 2018	Nov. 24, 2019
Fixed Attenuator Mini-Circuits	MDCS18N-10	MDCS18N-10-01	Apr. 15, 2019	Apr. 14, 2020
Loop Antenna	EM-6879	269	Sep. 16, 2019	Sep. 15, 2020
Preamplifier Agilent	310N	187226	Jun. 18, 2019	Jun. 17, 2020
Preamplifier Agilent	83017A	MY39501357	Jun. 18, 2019	Jun. 17, 2020
Power Meter Anritsu	ML2495A	1012010	Sep. 04, 2019	Sep. 03, 2020
Power Sensor Anritsu	MA2411B	1315050	Sep. 04, 2019	Sep. 03, 2020
RF signal cable ETS-LINDGREN	5D-FB	Cable-CH1-01(RFC -SMS-100-SMS-12 0+RFC-SMS-100-S MS-400)	Jun. 18, 2019	Jun. 17, 2020
RF signal cable ETS-LINDGREN	8D-FB	Cable-CH1-02(RFC -SMS-100-SMS-24)	Jun. 18, 2019	Jun. 17, 2020
Boresight Antenna Fixture	FBA-01	FBA-SIP01	NA	NA
Software BV ADT	E3 8.130425b	NA	NA	NA
Antenna Tower MF	NA	NA	NA	NA
Turn Table MF	NA	NA	NA	NA
Antenna Tower & Turn Table Controller MF	MF-7802	NA	NA	NA

- Note: 1. The calibration interval of the above test instruments is 12 months and the calibrations are traceable to NML/ROC and NIST/USA.
2. The test was performed in HsinTien Chamber 1.

#### 4.1.3 Test Procedures

##### **For Radiated Emission below 30 MHz**

- a. The EUT was placed on the top of a rotating table 0.8 meters above the ground at a 3 meter chamber room. The table was rotated 360 degrees to determine the position of the highest radiation.
- b. The EUT was set 3 meters away from the interference-receiving antenna, which was mounted on the top of a variable-height antenna tower.
- c. Parallel, perpendicular, and ground-parallel orientations of the antenna are set to make the measurement.
- d. For each suspected emission, the EUT was arranged to its worst case and the rotatable table was turned from 0 degrees to 360 degrees to find the maximum reading.
- e. The test-receiver system was set to Quasi-Peak Detect Function and Specified Bandwidth with Maximum Hold Mode.

##### **Note:**

1. The resolution bandwidth and video bandwidth of test receiver/spectrum analyzer is 9 kHz at frequency below 30 MHz.

##### **For Radiated Emission above 30 MHz**

- a. The EUT was placed on the top of a rotating table 0.8 meters (for 30 MHz ~ 1 GHz) / 1.5 meters (for above 1 GHz) above the ground at 3 meter chamber room for test. The table was rotated 360 degrees to determine the position of the highest radiation.
- b. The EUT was set 3 meters away from the interference-receiving antenna, which was mounted on the top of a variable-height antenna tower.
- c. The height of antenna is varied from one meter to four meters above the ground to determine the maximum value of the field strength. Both horizontal and vertical polarizations of the antenna are set to make the measurement.
- d. For each suspected emission, the EUT was arranged to its worst case and then the antenna was tuned to heights from 1 meter to 4 meters and the rotatable table was turned from 0 degrees to 360 degrees to find the maximum reading.
- e. The test-receiver system was set to quasi-peak detect function and specified bandwidth with maximum hold mode when the test frequency is below 1 GHz.
- f. The test-receiver system was set to peak and average detected function and specified bandwidth with maximum hold mode when the test frequency is above 1 GHz. If the peak reading value also meets average limit, measurement with the average detector is unnecessary.

##### **Note:**

1. The resolution bandwidth and video bandwidth of test receiver/spectrum analyzer is 120 kHz for Quasi-peak detection (QP) or Peak detection (PK) at frequency below 1 GHz.
2. The resolution bandwidth of test receiver/spectrum analyzer is 1 MHz and the video bandwidth is 3 MHz for Peak detection (PK) at frequency above 1 GHz.
3. The resolution bandwidth of test receiver/spectrum analyzer is 1 MHz and the video bandwidth is  $\geq 1/T$  (Duty cycle < 98 %) or 10 Hz (Duty cycle  $\geq 98$  %) for Average detection (AV) at frequency above 1 GHz.  
(11b: RBW = 1 MHz, VBW = 10 Hz ; 11g: RBW = 1 MHz, VBW = 1 kHz ;  
11n (HT20): RBW = 1 MHz, VBW = 10 Hz; 11n (HT40): RBW = 1 MHz, VBW = 10 Hz;  
11ax (HE20): RBW = 1 MHz, VBW = 10 Hz ; 11ax (HE40): RBW = 1 MHz, VBW = 10 Hz )
4. All modes of operation were investigated and the worst-case emissions are reported.

4.1.4 Deviation from Test Standard

No deviation.

4.1.5 Test Set Up

<Radiated Emission below 30 MHz>

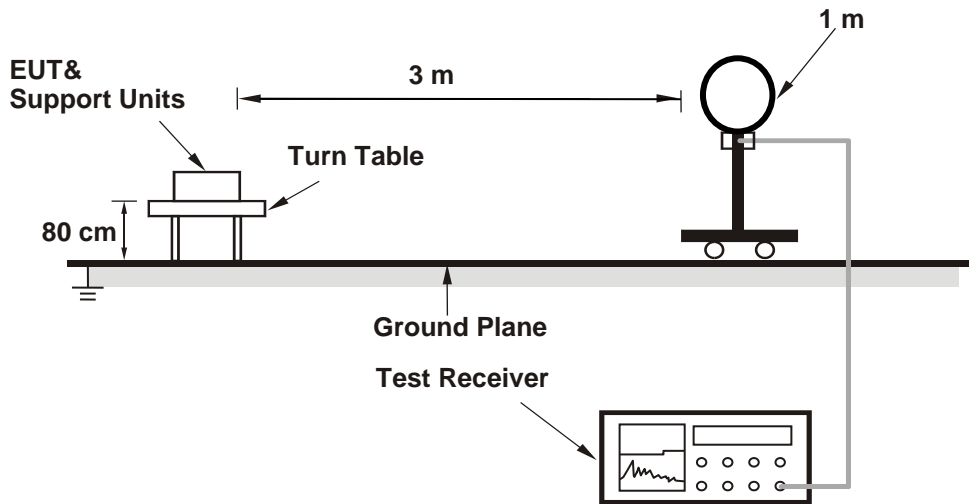

<Radiated Emission 30 MHz to 1 GHz>

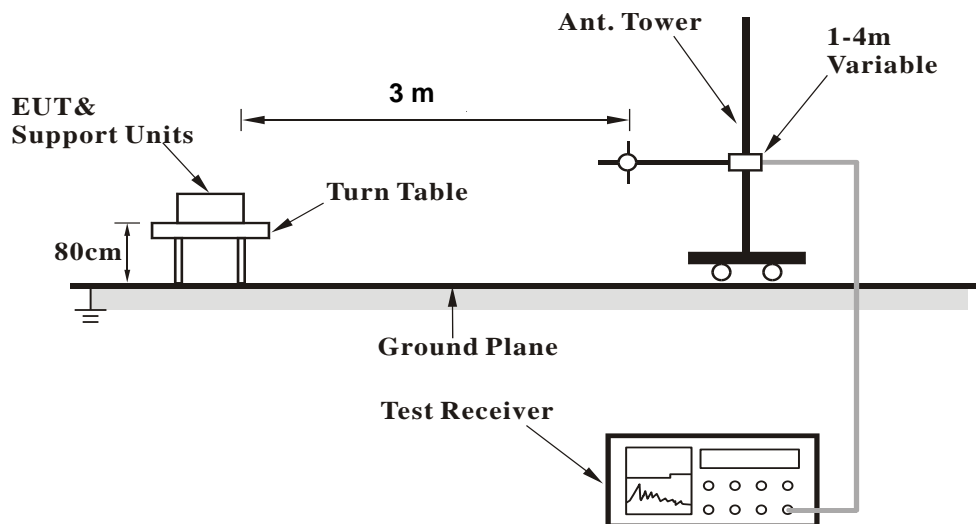



**<Radiated Emission above 1 GHz>**

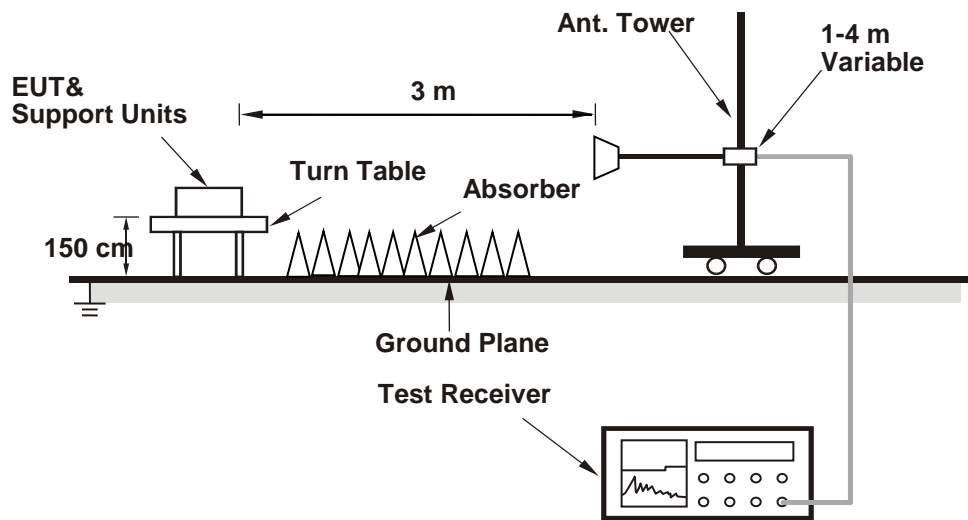

For the actual test configuration, please refer to the attached file (Test Setup Photo).

**4.1.6 EUT Operating Conditions**

- a. Placed the EUT on a testing table.
- b. Use the software to control the EUT under transmission condition continuously at specific channel frequency.

4.1.7 Test Results

Above 1 GHz Data :  
802.11b

EUT Test Condition		Measurement Detail	
Channel	Channel 1	Frequency Range	1 GHz ~ 25 GHz
Input Power	120 Vac, 60 Hz	Detector Function	Peak (PK) Average (AV)
Environmental Conditions	25 deg. C, 65 % RH	Tested By	Charles Hsiao

Antenna Polarity & Test Distance: Horizontal at 3 m								
Frequency (MHz)	Emission Level (dBuV/m)	Read Level (dBuV)	Factor (dB/m)	Limit (dBuV/m)	Margin (dB)	Antenna Height (cm)	Table Angle (Degree)	Remark
2386.59	41.32	36.83	4.49	54	-12.68	231	46	Average
2386.59	52.22	47.73	4.49	74	-21.78	231	46	Peak
2412	98.55	94	4.55			231	46	Average
2412	101.73	97.18	4.55			231	46	Peak
4824	41.95	31.66	10.29	54	-12.05	185	177	Average
4824	48.56	38.27	10.29	74	-25.44	185	177	Peak

Antenna Polarity & Test Distance: Vertical at 3 m								
Frequency (MHz)	Emission Level (dBuV/m)	Read Level (dBuV)	Factor (dB/m)	Limit (dBuV/m)	Margin (dB)	Antenna Height (cm)	Table Angle (Degree)	Remark
2386.5	43.77	39.28	4.49	54	-10.23	247	46	Average
2386.5	53.04	48.55	4.49	74	-20.96	247	46	Peak
2412	102.37	97.82	4.55			247	46	Average
2412	105.76	101.21	4.55			247	46	Peak
4824	41.87	31.58	10.29	54	-12.13	133	325	Average
4824	47.73	37.44	10.29	74	-26.27	133	325	Peak

Remarks:

- Emission Level = Read Level + Factor  
Margin value = Emission level – Limit value
- 2412 MHz: Fundamental frequency.
- The emission levels of other frequencies were very low against the limit.

EUT Test Condition		Measurement Detail	
Channel	Channel 6	Frequency Range	1 GHz ~ 25 GHz
Input Power	120 Vac, 60 Hz	Detector Function	Peak (PK) Average (AV)
Environmental Conditions	25 deg. C, 65 % RH	Tested By	Charles Hsiao

Antenna Polarity & Test Distance: Horizontal at 3 m								
Frequency (MHz)	Emission Level (dBuV/m)	Read Level (dBuV)	Factor (dB/m)	Limit (dBuV/m)	Margin (dB)	Antenna Height (cm)	Table Angle (Degree)	Remark
2373.09	40.45	36	4.45	54	-13.55	231	46	Average
2373.09	51.46	47.01	4.45	74	-22.54	231	46	Peak
2437	98.66	94.07	4.59			231	46	Average
2437	101.02	96.43	4.59			231	46	Peak
2495.92	40.67	36	4.67	54	-13.33	231	46	Average
2495.92	52.33	47.66	4.67	74	-21.67	231	46	Peak
4874	41.84	31.63	10.21	54	-12.16	134	199	Average
4874	47.77	37.56	10.21	74	-26.23	134	199	Peak

Antenna Polarity & Test Distance: Vertical at 3 m								
Frequency (MHz)	Emission Level (dBuV/m)	Read Level (dBuV)	Factor (dB/m)	Limit (dBuV/m)	Margin (dB)	Antenna Height (cm)	Table Angle (Degree)	Remark
2389.83	40.75	36.25	4.5	54	-13.25	247	46	Average
2389.83	51.79	47.29	4.5	74	-22.21	247	46	Peak
2437	102.48	97.89	4.59			247	46	Average
2437	105.45	100.86	4.59			247	46	Peak
2487.36	41.34	36.68	4.66	54	-12.66	247	46	Average
2487.36	52.5	47.84	4.66	74	-21.5	247	46	Peak
4874	41.78	31.57	10.21	54	-12.22	166	208	Average
4874	47.91	37.7	10.21	74	-26.09	166	208	Peak

Remarks:

- Emission Level = Read Level + Factor  
Margin value = Emission level – Limit value
- 2437 MHz: Fundamental frequency.
- The emission levels of other frequencies were very low against the limit.

EUT Test Condition		Measurement Detail	
Channel	Channel 11	Frequency Range	1 GHz ~ 25 GHz
Input Power	120 Vac, 60 Hz	Detector Function	Peak (PK) Average (AV)
Environmental Conditions	25 deg. C, 65 % RH	Tested By	Charles Hsiao

Antenna Polarity & Test Distance: Horizontal at 3 m								
Frequency (MHz)	Emission Level (dBuV/m)	Read Level (dBuV)	Factor (dB/m)	Limit (dBuV/m)	Margin (dB)	Antenna Height (cm)	Table Angle (Degree)	Remark
2462	98.78	94.16	4.62			258	46	Average
2462	101.7	97.08	4.62			258	46	Peak
2489.28	40.75	36.07	4.68	54	-13.25	231	46	Average
2489.28	51.71	47.03	4.68	74	-22.29	231	46	Peak
4924	41.7	31.45	10.25	54	-12.3	195	5	Average
4924	48.7	38.45	10.25	74	-25.3	195	5	Peak
Antenna Polarity & Test Distance: Vertical at 3 m								
Frequency (MHz)	Emission Level (dBuV/m)	Read Level (dBuV)	Factor (dB/m)	Limit (dBuV/m)	Margin (dB)	Antenna Height (cm)	Table Angle (Degree)	Remark
2462	102.15	97.53	4.62			247	46	Average
2462	105.35	100.73	4.62			247	46	Peak
2490.92	43.08	38.4	4.68	54	-10.92	247	46	Average
2490.92	52.94	48.26	4.68	74	-21.06	247	46	Peak
4924	41.73	31.48	10.25	54	-12.27	155	164	Average
4924	48.56	38.31	10.25	74	-25.44	155	164	Peak

Remarks:

- Emission Level = Read Level + Factor  
Margin value = Emission level – Limit value
- 2462 MHz: Fundamental frequency.
- The emission levels of other frequencies were very low against the limit.

EUT Test Condition		Measurement Detail	
Channel	Channel 12	Frequency Range	1 GHz ~ 25 GHz
Input Power	120 Vac, 60 Hz	Detector Function	Peak (PK) Average (AV)
Environmental Conditions	25 deg. C, 65 % RH	Tested By	Charles Hsiao

Antenna Polarity & Test Distance: Horizontal at 3 m								
Frequency (MHz)	Emission Level (dBuV/m)	Read Level (dBuV)	Factor (dB/m)	Limit (dBuV/m)	Margin (dB)	Antenna Height (cm)	Table Angle (Degree)	Remark
2467	98.16	93.53	4.63			258	46	Average
2467	101.01	96.38	4.63			258	46	Peak
2484.72	42.31	37.65	4.66	54	-11.69	258	46	Average
2484.72	52.15	47.49	4.66	74	-21.85	258	46	Peak
4934	41.74	31.48	10.26	54	-12.26	178	199	Average
4934	48.59	38.33	10.26	74	-25.41	178	199	Peak
Antenna Polarity & Test Distance: Vertical at 3 m								
Frequency (MHz)	Emission Level (dBuV/m)	Read Level (dBuV)	Factor (dB/m)	Limit (dBuV/m)	Margin (dB)	Antenna Height (cm)	Table Angle (Degree)	Remark
2467	102.41	97.78	4.63			247	46	Average
2467	105.29	100.66	4.63			247	46	Peak
2484.48	43.85	39.19	4.66	54	-10.15	247	46	Average
2484.48	53.18	48.52	4.66	74	-20.82	247	46	Peak
4934	41.63	31.37	10.26	54	-12.37	165	335	Average
4934	49.07	38.81	10.26	74	-24.93	165	335	Peak

Remarks:

- Emission Level = Read Level + Factor  
Margin value = Emission level – Limit value
- 2467 MHz: Fundamental frequency.
- The emission levels of other frequencies were very low against the limit.

EUT Test Condition		Measurement Detail	
Channel	Channel 13	Frequency Range	1 GHz ~ 25 GHz
Input Power	120 Vac, 60 Hz	Detector Function	Peak (PK) Average (AV)
Environmental Conditions	25 deg. C, 65 % RH	Tested By	Charles Hsiao

Antenna Polarity & Test Distance: Horizontal at 3 m								
Frequency (MHz)	Emission Level (dBuV/m)	Read Level (dBuV)	Factor (dB/m)	Limit (dBuV/m)	Margin (dB)	Antenna Height (cm)	Table Angle (Degree)	Remark
2472	98.56	93.92	4.64			258	46	Average
2472	101.44	96.8	4.64			258	46	Peak
2484.72	43.18	38.52	4.66	54	-10.82	258	46	Average
2484.72	58.99	54.33	4.66	74	-15.01	258	46	Peak
4944	42.3	31.95	10.35	54	-11.7	164	322	Average
4944	48.5	38.15	10.35	74	-25.5	164	322	Peak
Antenna Polarity & Test Distance: Vertical at 3 m								
Frequency (MHz)	Emission Level (dBuV/m)	Read Level (dBuV)	Factor (dB/m)	Limit (dBuV/m)	Margin (dB)	Antenna Height (cm)	Table Angle (Degree)	Remark
2472	102.58	97.94	4.64			247	46	Average
2472	105.38	100.74	4.64			247	46	Peak
2483.52	46.76	42.1	4.66	54	-7.24	247	46	Average
2483.52	64.06	59.4	4.66	74	-9.94	247	46	Peak
4944	41.91	31.56	10.35	54	-12.09	187	195	Average
4944	49.24	38.89	10.35	74	-24.76	187	195	Peak

Remarks:

- Emission Level = Read Level + Factor  
Margin value = Emission level – Limit value
- 2472 MHz: Fundamental frequency.
- The emission levels of other frequencies were very low against the limit.

## 802.11g

EUT Test Condition		Measurement Detail	
Channel	Channel 1	Frequency Range	1 GHz ~ 25 GHz
Input Power	120 Vac, 60 Hz	Detector Function	Peak (PK) Average (AV)
Environmental Conditions	25 deg. C, 65 % RH	Tested By	Charles Hsiao

Antenna Polarity & Test Distance: Horizontal at 3 m								
Frequency (MHz)	Emission Level (dBuV/m)	Read Level (dBuV)	Factor (dB/m)	Limit (dBuV/m)	Margin (dB)	Antenna Height (cm)	Table Angle (Degree)	Remark
2389.92	45.54	41.04	4.5	54	-8.46	231	46	Average
2389.92	57.34	52.84	4.5	74	-16.66	231	46	Peak
2412	96.57	92.02	4.55			231	46	Average
2412	103.76	99.21	4.55			231	46	Peak
4824	41.82	31.53	10.29	54	-12.18	190	60	Average
4824	48.31	38.02	10.29	74	-25.69	190	60	Peak
Antenna Polarity & Test Distance: Vertical at 3 m								
Frequency (MHz)	Emission Level (dBuV/m)	Read Level (dBuV)	Factor (dB/m)	Limit (dBuV/m)	Margin (dB)	Antenna Height (cm)	Table Angle (Degree)	Remark
2389.74	49.36	44.87	4.49	54	-4.64	247	46	Average
2389.74	60.36	55.87	4.49	74	-13.64	247	46	Peak
2412	100.24	95.69	4.55			247	46	Average
2412	107.52	102.97	4.55			247	46	Peak
4824	41.74	31.45	10.29	54	-12.26	134	322	Average
4824	47.94	37.65	10.29	74	-26.06	134	322	Peak

## Remarks:

- Emission Level = Read Level + Factor  
Margin value = Emission level – Limit value
- 2412 MHz: Fundamental frequency.
- The emission levels of other frequencies were very low against the limit.

EUT Test Condition		Measurement Detail	
Channel	Channel 6	Frequency Range	1 GHz ~ 25 GHz
Input Power	120 Vac, 60 Hz	Detector Function	Peak (PK) Average (AV)
Environmental Conditions	25 deg. C, 65 % RH	Tested By	Charles Hsiao

Antenna Polarity & Test Distance: Horizontal at 3 m								
Frequency (MHz)	Emission Level (dBuV/m)	Read Level (dBuV)	Factor (dB/m)	Limit (dBuV/m)	Margin (dB)	Antenna Height (cm)	Table Angle (Degree)	Remark
2386.05	40.5	36.01	4.49	54	-13.5	231	46	Average
2386.05	52.19	47.7	4.49	74	-21.81	231	46	Peak
2437	96.53	91.94	4.59			231	46	Average
2437	103.49	98.9	4.59			231	46	Peak
2493.88	40.76	36.09	4.67	54	-13.24	231	46	Average
2493.88	52.22	47.55	4.67	74	-21.78	231	46	Peak
4874	41.78	31.57	10.21	54	-12.22	148	88	Average
4874	48.47	38.26	10.21	74	-25.53	148	88	Peak
Antenna Polarity & Test Distance: Vertical at 3 m								
Frequency (MHz)	Emission Level (dBuV/m)	Read Level (dBuV)	Factor (dB/m)	Limit (dBuV/m)	Margin (dB)	Antenna Height (cm)	Table Angle (Degree)	Remark
2388.03	40.75	36.26	4.49	54	-13.25	247	46	Average
2388.03	51.86	47.37	4.49	74	-22.14	247	46	Peak
2437	100.61	96.02	4.59			247	46	Average
2437	107.83	103.24	4.59			247	46	Peak
2483.72	41.29	36.63	4.66	54	-12.71	247	46	Average
2483.72	52.54	47.88	4.66	74	-21.46	247	46	Peak
4874	41.46	31.25	10.21	54	-12.54	188	208	Average
4874	48	37.79	10.21	74	-26	188	208	Peak

Remarks:

- Emission Level = Read Level + Factor  
Margin value = Emission level – Limit value
- 2437 MHz: Fundamental frequency.
- The emission levels of other frequencies were very low against the limit.



EUT Test Condition		Measurement Detail	
Channel	Channel 11	Frequency Range	1 GHz ~ 25 GHz
Input Power	120 Vac, 60 Hz	Detector Function	Peak (PK) Average (AV)
Environmental Conditions	25 deg. C, 65 % RH	Tested By	Charles Hsiao

Antenna Polarity & Test Distance: Horizontal at 3 m								
Frequency (MHz)	Emission Level (dBuV/m)	Read Level (dBuV)	Factor (dB/m)	Limit (dBuV/m)	Margin (dB)	Antenna Height (cm)	Table Angle (Degree)	Remark
2462	96.77	92.15	4.62			258	46	Average
2462	103.51	98.89	4.62			258	46	Peak
2483.68	44.78	40.12	4.66	54	-9.22	258	46	Average
2483.68	56.35	51.69	4.66	74	-17.65	258	46	Peak
4924	41.89	31.64	10.25	54	-12.11	186	264	Average
4924	48.84	38.59	10.25	74	-25.16	186	264	Peak
Antenna Polarity & Test Distance: Vertical at 3 m								
Frequency (MHz)	Emission Level (dBuV/m)	Read Level (dBuV)	Factor (dB/m)	Limit (dBuV/m)	Margin (dB)	Antenna Height (cm)	Table Angle (Degree)	Remark
2462	100.49	95.87	4.62			247	46	Average
2462	107.03	102.41	4.62			247	46	Peak
2483.56	47.93	43.27	4.66	54	-6.07	247	46	Average
2483.56	60.67	56.01	4.66	74	-13.33	247	46	Peak
4924	41.83	31.58	10.25	54	-12.17	134	155	Average
4924	47.81	37.56	10.25	74	-26.19	134	155	Peak

Remarks:

- Emission Level = Read Level + Factor  
Margin value = Emission level – Limit value
- 2462 MHz: Fundamental frequency.
- The emission levels of other frequencies were very low against the limit.

EUT Test Condition		Measurement Detail	
Channel	Channel 12	Frequency Range	1 GHz ~ 25 GHz
Input Power	120 Vac, 60 Hz	Detector Function	Peak (PK) Average (AV)
Environmental Conditions	25 deg. C, 65 % RH	Tested By	Charles Hsiao

Antenna Polarity & Test Distance: Horizontal at 3 m								
Frequency (MHz)	Emission Level (dBuV/m)	Read Level (dBuV)	Factor (dB/m)	Limit (dBuV/m)	Margin (dB)	Antenna Height (cm)	Table Angle (Degree)	Remark
2467	95.43	90.8	4.63			258	46	Average
2467	102.01	97.38	4.63			258	46	Peak
2483.52	48.91	44.25	4.66	54	-5.09	258	46	Average
2483.52	59.24	54.58	4.66	74	-14.76	258	46	Peak
4934	41.85	31.59	10.26	54	-12.15	164	155	Average
4934	48.13	37.87	10.26	74	-25.87	164	155	Peak
Antenna Polarity & Test Distance: Vertical at 3 m								
Frequency (MHz)	Emission Level (dBuV/m)	Read Level (dBuV)	Factor (dB/m)	Limit (dBuV/m)	Margin (dB)	Antenna Height (cm)	Table Angle (Degree)	Remark
2467	99.95	95.32	4.63			247	46	Average
2467	106.51	101.88	4.63			247	46	Peak
2483.52	52.92	48.26	4.66	54	-1.08	247	46	Average
2483.52	63.8	59.14	4.66	74	-10.2	247	46	Peak
4934	41.8	31.54	10.26	54	-12.2	187	177	Average
4934	48.17	37.91	10.26	74	-25.83	187	177	Peak

Remarks:

- Emission Level = Read Level + Factor  
Margin value = Emission level – Limit value
- 2467 MHz: Fundamental frequency.
- The emission levels of other frequencies were very low against the limit.

EUT Test Condition		Measurement Detail	
Channel	Channel 13	Frequency Range	1 GHz ~ 25 GHz
Input Power	120 Vac, 60 Hz	Detector Function	Peak (PK) Average (AV)
Environmental Conditions	25 deg. C, 65 % RH	Tested By	Charles Hsiao

Antenna Polarity & Test Distance: Horizontal at 3 m								
Frequency (MHz)	Emission Level (dBuV/m)	Read Level (dBuV)	Factor (dB/m)	Limit (dBuV/m)	Margin (dB)	Antenna Height (cm)	Table Angle (Degree)	Remark
2472	91.48	86.84	4.64			258	46	Average
2472	98.68	94.04	4.64			258	46	Peak
2483.64	43.13	38.47	4.66	54	-10.87	258	46	Average
2483.64	65.47	60.81	4.66	74	-8.53	258	46	Peak
4944	41.98	31.63	10.35	54	-12.02	167	286	Average
4944	48.58	38.23	10.35	74	-25.42	167	286	Peak
Antenna Polarity & Test Distance: Vertical at 3 m								
Frequency (MHz)	Emission Level (dBuV/m)	Read Level (dBuV)	Factor (dB/m)	Limit (dBuV/m)	Margin (dB)	Antenna Height (cm)	Table Angle (Degree)	Remark
2472	95.15	90.51	4.64			247	46	Average
2472	102.28	97.64	4.64			247	46	Peak
2483.6	52.55	47.89	4.66	54	-1.45	247	46	Average
2483.6	71.85	67.19	4.66	74	-2.15	247	46	Peak
4944	41.6	31.25	10.35	54	-12.4	121	111	Average
4944	48.12	37.77	10.35	74	-25.88	121	111	Peak

Remarks:

- Emission Level = Read Level + Factor  
Margin value = Emission level – Limit value
- 2472 MHz: Fundamental frequency.
- The emission levels of other frequencies were very low against the limit.

802.11n (HT20)

EUT Test Condition		Measurement Detail	
Channel	Channel 1	Frequency Range	1 GHz ~ 25 GHz
Input Power	120 Vac, 60 Hz	Detector Function	Peak (PK) Average (AV)
Environmental Conditions	25 deg. C, 65 % RH	Tested By	Harry Hsueh

Antenna Polarity & Test Distance: Horizontal at 3 m								
Frequency (MHz)	Emission Level (dBuV/m)	Read Level (dBuV)	Factor (dB/m)	Limit (dBuV/m)	Margin (dB)	Antenna Height (cm)	Table Angle (Degree)	Remark
2388.3	44.55	40.06	4.49	54	-9.45	299	57	Average
2388.3	54.87	50.38	4.49	74	-19.13	299	57	Peak
2412	97.23	92.68	4.55			299	57	Average
2412	105.57	101.02	4.55			299	57	Peak
4824	41.75	31.46	10.29	54	-12.25	174	14	Average
4824	49.77	39.48	10.29	74	-24.23	174	14	Peak
Antenna Polarity & Test Distance: Vertical at 3 m								
Frequency (MHz)	Emission Level (dBuV/m)	Read Level (dBuV)	Factor (dB/m)	Limit (dBuV/m)	Margin (dB)	Antenna Height (cm)	Table Angle (Degree)	Remark
2389.47	52.41	47.92	4.49	54	-1.59	273	345	Average
2389.47	62.41	57.92	4.49	74	-11.59	273	345	Peak
2412	102.57	98.02	4.55			273	345	Average
2412	110.16	105.61	4.55			273	345	Peak
4824	41.84	31.55	10.29	54	-12.16	133	275	Average
4824	49.54	39.25	10.29	74	-24.46	133	275	Peak

Remarks:

- Emission Level = Read Level + Factor  
Margin value = Emission level – Limit value
- 2412 MHz: Fundamental frequency.
- The emission levels of other frequencies were very low against the limit.

EUT Test Condition		Measurement Detail	
Channel	Channel 6	Frequency Range	1 GHz ~ 25 GHz
Input Power	120 Vac, 60 Hz	Detector Function	Peak (PK) Average (AV)
Environmental Conditions	25 deg. C, 65 % RH	Tested By	Harry Hsueh

Antenna Polarity & Test Distance: Horizontal at 3 m								
Frequency (MHz)	Emission Level (dBuV/m)	Read Level (dBuV)	Factor (dB/m)	Limit (dBuV/m)	Margin (dB)	Antenna Height (cm)	Table Angle (Degree)	Remark
2389.56	40.84	36.35	4.49	54	-13.16	299	57	Average
2389.56	51.77	47.28	4.49	74	-22.23	299	57	Peak
2437	99.29	94.7	4.59			299	57	Average
2437	107.39	102.8	4.59			299	57	Peak
2483.76	41.1	36.44	4.66	54	-12.9	299	57	Average
2483.76	52.25	47.59	4.66	74	-21.75	299	57	Peak
4874	41.83	31.62	10.21	54	-12.17	199	156	Average
4874	49.53	39.32	10.21	74	-24.47	199	156	Peak

Antenna Polarity & Test Distance: Vertical at 3 m								
Frequency (MHz)	Emission Level (dBuV/m)	Read Level (dBuV)	Factor (dB/m)	Limit (dBuV/m)	Margin (dB)	Antenna Height (cm)	Table Angle (Degree)	Remark
2389.92	42.86	38.36	4.5	54	-11.14	273	345	Average
2389.92	54.81	50.31	4.5	74	-19.19	273	345	Peak
2437	103.62	99.03	4.59			273	345	Average
2437	111.39	106.8	4.59			273	345	Peak
2483.52	41.98	37.32	4.66	54	-12.02	273	345	Average
2483.52	53.33	48.67	4.66	74	-20.67	273	345	Peak
4874	41.77	31.56	10.21	54	-12.23	145	188	Average
4874	48.59	38.38	10.21	74	-25.41	145	188	Peak

Remarks:

- Emission Level = Read Level + Factor  
Margin value = Emission level – Limit value
- 2437 MHz: Fundamental frequency.
- The emission levels of other frequencies were very low against the limit.

EUT Test Condition		Measurement Detail	
Channel	Channel 11	Frequency Range	1 GHz ~ 25 GHz
Input Power	120 Vac, 60 Hz	Detector Function	Peak (PK) Average (AV)
Environmental Conditions	25 deg. C, 65 % RH	Tested By	Harry Hsueh

Antenna Polarity & Test Distance: Horizontal at 3 m								
Frequency (MHz)	Emission Level (dBuV/m)	Read Level (dBuV)	Factor (dB/m)	Limit (dBuV/m)	Margin (dB)	Antenna Height (cm)	Table Angle (Degree)	Remark
2462	98.32	93.7	4.62			299	58	Average
2462	106.96	102.34	4.62			299	58	Peak
2483.76	49.19	44.53	4.66	54	-4.81	299	58	Average
2483.76	62.44	57.78	4.66	74	-11.56	299	58	Peak
4924	41.71	31.46	10.25	54	-12.29	144	176	Average
4924	49.46	39.21	10.25	74	-24.54	144	176	Peak
Antenna Polarity & Test Distance: Vertical at 3 m								
Frequency (MHz)	Emission Level (dBuV/m)	Read Level (dBuV)	Factor (dB/m)	Limit (dBuV/m)	Margin (dB)	Antenna Height (cm)	Table Angle (Degree)	Remark
2462	103.34	98.72	4.62			273	345	Average
2462	111.5	106.88	4.62			273	345	Peak
2483.52	52.85	48.19	4.66	54	-1.15	273	345	Average
2483.52	62.22	57.56	4.66	74	-11.78	273	345	Peak
4924	41.66	31.41	10.25	54	-12.34	188	125	Average
4924	48.24	37.99	10.25	74	-25.76	188	125	Peak

Remarks:

- Emission Level = Read Level + Factor  
Margin value = Emission level – Limit value
- 2462 MHz: Fundamental frequency.
- The emission levels of other frequencies were very low against the limit.

EUT Test Condition		Measurement Detail	
Channel	Channel 12	Frequency Range	1 GHz ~ 25 GHz
Input Power	120 Vac, 60 Hz	Detector Function	Peak (PK) Average (AV)
Environmental Conditions	25 deg. C, 65 % RH	Tested By	Harry Hsueh

Antenna Polarity & Test Distance: Horizontal at 3 m								
Frequency (MHz)	Emission Level (dBuV/m)	Read Level (dBuV)	Factor (dB/m)	Limit (dBuV/m)	Margin (dB)	Antenna Height (cm)	Table Angle (Degree)	Remark
2467	93.67	89.04	4.63			299	57	Average
2467	101.83	97.2	4.63			299	57	Peak
2483.52	45.03	40.37	4.66	54	-8.97	299	57	Average
2483.52	54.41	49.75	4.66	74	-19.59	299	57	Peak
4934	41.73	31.47	10.26	54	-12.27	174	145	Average
4934	49	38.74	10.26	74	-25	174	145	Peak
Antenna Polarity & Test Distance: Vertical at 3 m								
Frequency (MHz)	Emission Level (dBuV/m)	Read Level (dBuV)	Factor (dB/m)	Limit (dBuV/m)	Margin (dB)	Antenna Height (cm)	Table Angle (Degree)	Remark
2467	98.34	93.71	4.63			273	345	Average
2467	106.95	102.32	4.63			273	345	Peak
2483.52	51.8	47.14	4.66	54	-2.2	254	345	Average
2483.52	60.73	56.07	4.66	74	-13.27	254	345	Peak
4934	41.95	31.69	10.26	54	-12.05	133	274	Average
4934	49.12	38.86	10.26	74	-24.88	133	274	Peak

Remarks:

- Emission Level = Read Level + Factor  
Margin value = Emission level – Limit value
- 2467 MHz: Fundamental frequency.
- The emission levels of other frequencies were very low against the limit.

EUT Test Condition		Measurement Detail	
Channel	Channel 13	Frequency Range	1 GHz ~ 25 GHz
Input Power	120 Vac, 60 Hz	Detector Function	Peak (PK) Average (AV)
Environmental Conditions	25 deg. C, 65 % RH	Tested By	Harry Hsueh

Antenna Polarity & Test Distance: Horizontal at 3 m								
Frequency (MHz)	Emission Level (dBuV/m)	Read Level (dBuV)	Factor (dB/m)	Limit (dBuV/m)	Margin (dB)	Antenna Height (cm)	Table Angle (Degree)	Remark
2472	93.69	89.05	4.64			299	57	Average
2472	100.72	96.08	4.64			299	57	Peak
2483.52	44.76	40.1	4.66	54	-9.24	299	57	Average
2483.52	56.78	52.12	4.66	74	-17.22	299	57	Peak
4944	41.47	31.12	10.35	54	-12.53	178	88	Average
4944	48.27	37.92	10.35	74	-25.73	178	88	Peak
Antenna Polarity & Test Distance: Vertical at 3 m								
Frequency (MHz)	Emission Level (dBuV/m)	Read Level (dBuV)	Factor (dB/m)	Limit (dBuV/m)	Margin (dB)	Antenna Height (cm)	Table Angle (Degree)	Remark
2472	97.35	92.71	4.64			273	345	Average
2472	105.38	100.74	4.64			273	345	Peak
2483.52	50.35	45.69	4.66	54	-3.65	273	345	Average
2483.52	68.12	63.46	4.66	74	-5.88	273	345	Peak
4944	41.79	31.44	10.35	54	-12.21	118	42	Average
4944	50.08	39.73	10.35	74	-23.92	118	42	Peak

Remarks:

- Emission Level = Read Level + Factor  
Margin value = Emission level – Limit value
- 2472 MHz: Fundamental frequency.
- The emission levels of other frequencies were very low against the limit.



### 802.11n (HT40)

EUT Test Condition		Measurement Detail	
Channel	Channel 3	Frequency Range	1 GHz ~ 25 GHz
Input Power	120 Vac, 60 Hz	Detector Function	Peak (PK) Average (AV)
Environmental Conditions	25 deg. C, 65 % RH	Tested By	Charles Hsiao

Antenna Polarity & Test Distance: Horizontal at 3 m								
Frequency (MHz)	Emission Level (dBuV/m)	Read Level (dBuV)	Factor (dB/m)	Limit (dBuV/m)	Margin (dB)	Antenna Height (cm)	Table Angle (Degree)	Remark
2382.36	45.25	40.78	4.47	54	-8.75	299	57	Average
2382.36	54.7	50.23	4.47	74	-19.3	299	57	Peak
2422	95.57	91.01	4.56			299	57	Average
2422	102.44	97.88	4.56			299	57	Peak
2491.92	40.98	36.31	4.67	54	-13.02	299	57	Average
2491.92	52.47	47.8	4.67	74	-21.53	299	57	Peak
4844	41.99	31.76	10.23	54	-12.01	165	55	Average
4844	49.07	38.84	10.23	74	-24.93	165	55	Peak
Antenna Polarity & Test Distance: Vertical at 3 m								
Frequency (MHz)	Emission Level (dBuV/m)	Read Level (dBuV)	Factor (dB/m)	Limit (dBuV/m)	Margin (dB)	Antenna Height (cm)	Table Angle (Degree)	Remark
2389.83	52.06	47.56	4.5	54	-1.94	273	347	Average
2389.83	61.03	56.53	4.5	74	-12.97	273	347	Peak
2422	100.36	95.8	4.56			273	345	Average
2422	107.84	103.28	4.56			273	345	Peak
2485.56	41.54	36.88	4.66	54	-12.46	273	345	Average
2485.56	52.83	48.17	4.66	74	-21.17	273	345	Peak
4844	41.81	31.58	10.23	54	-12.19	183	148	Average
4844	48.97	38.74	10.23	74	-25.03	183	148	Peak

Remarks:

- Emission Level = Read Level + Factor  
Margin value = Emission level – Limit value
- 2422 MHz: Fundamental frequency.
- The emission levels of other frequencies were very low against the limit.

EUT Test Condition		Measurement Detail	
Channel	Channel 6	Frequency Range	1 GHz ~ 25 GHz
Input Power	120 Vac, 60 Hz	Detector Function	Peak (PK) Average (AV)
Environmental Conditions	25 deg. C, 65 % RH	Tested By	Charles Hsiao

Antenna Polarity & Test Distance: Horizontal at 3 m								
Frequency (MHz)	Emission Level (dBuV/m)	Read Level (dBuV)	Factor (dB/m)	Limit (dBuV/m)	Margin (dB)	Antenna Height (cm)	Table Angle (Degree)	Remark
2389.38	50.09	45.6	4.49	54	-3.91	299	57	Average
2389.38	61.26	56.77	4.49	74	-12.74	299	57	Peak
2437	97.56	92.97	4.59			299	57	Average
2437	104.07	99.48	4.59			299	57	Peak
2483.52	48.37	43.71	4.66	54	-5.63	299	57	Average
2483.52	60.54	55.88	4.66	74	-13.46	299	57	Peak
4874	41.98	31.77	10.21	54	-12.02	199	208	Average
4874	48.83	38.62	10.21	74	-25.17	199	208	Peak

Antenna Polarity & Test Distance: Vertical at 3 m								
Frequency (MHz)	Emission Level (dBuV/m)	Read Level (dBuV)	Factor (dB/m)	Limit (dBuV/m)	Margin (dB)	Antenna Height (cm)	Table Angle (Degree)	Remark
2389.56	52.62	48.13	4.49	54	-1.38	273	345	Average
2389.56	65.27	60.78	4.49	74	-8.73	273	345	Peak
2437	102.53	97.94	4.59			273	345	Average
2437	109.42	104.83	4.59			273	345	Peak
2483.56	49.89	45.23	4.66	54	-4.11	273	345	Average
2483.56	61.8	57.14	4.66	74	-12.2	273	345	Peak
4874	42.2	31.99	10.21	54	-11.8	148	169	Average
4874	48.55	38.34	10.21	74	-25.45	148	169	Peak

Remarks:

- Emission Level = Read Level + Factor  
Margin value = Emission level – Limit value
- 2437 MHz: Fundamental frequency.
- The emission levels of other frequencies were very low against the limit.

EUT Test Condition		Measurement Detail	
Channel	Channel 9	Frequency Range	1 GHz ~ 25 GHz
Input Power	120 Vac, 60 Hz	Detector Function	Peak (PK) Average (AV)
Environmental Conditions	25 deg. C, 65 % RH	Tested By	Charles Hsiao

Antenna Polarity & Test Distance: Horizontal at 3 m								
Frequency (MHz)	Emission Level (dBuV/m)	Read Level (dBuV)	Factor (dB/m)	Limit (dBuV/m)	Margin (dB)	Antenna Height (cm)	Table Angle (Degree)	Remark
2389.83	41.52	37.02	4.5	54	-12.48	299	57	Average
2389.83	52.61	48.11	4.5	74	-21.39	299	57	Peak
2452	95.67	91.07	4.6			299	57	Average
2452	102.99	98.39	4.6			299	57	Peak
2483.56	46.72	42.06	4.66	54	-7.28	299	57	Average
2483.56	58.16	53.5	4.66	74	-15.84	299	57	Peak
4904	41.58	31.44	10.14	54	-12.42	185	202	Average
4904	47.73	37.59	10.14	74	-26.27	185	202	Peak

Antenna Polarity & Test Distance: Vertical at 3 m								
Frequency (MHz)	Emission Level (dBuV/m)	Read Level (dBuV)	Factor (dB/m)	Limit (dBuV/m)	Margin (dB)	Antenna Height (cm)	Table Angle (Degree)	Remark
2389.74	44.08	39.59	4.49	54	-9.92	273	345	Average
2389.74	56.33	51.84	4.49	74	-17.67	273	345	Peak
2452	100.47	95.87	4.6			273	345	Average
2452	107.92	103.32	4.6			273	345	Peak
2485.24	52.88	48.22	4.66	54	-1.12	273	345	Average
2485.24	63.2	58.54	4.66	74	-10.8	273	345	Peak
4904	41.92	31.78	10.14	54	-12.08	133	324	Average
4904	48.63	38.49	10.14	74	-25.37	133	324	Peak

Remarks:

- Emission Level = Read Level + Factor  
Margin value = Emission level – Limit value
- 2452 MHz: Fundamental frequency.
- The emission levels of other frequencies were very low against the limit.

EUT Test Condition		Measurement Detail	
Channel	Channel 10	Frequency Range	1 GHz ~ 25 GHz
Input Power	120 Vac, 60 Hz	Detector Function	Peak (PK) Average (AV)
Environmental Conditions	25 deg. C, 65 % RH	Tested By	Charles Hsiao

Antenna Polarity & Test Distance: Horizontal at 3 m								
Frequency (MHz)	Emission Level (dBuV/m)	Read Level (dBuV)	Factor (dB/m)	Limit (dBuV/m)	Margin (dB)	Antenna Height (cm)	Table Angle (Degree)	Remark
2389.02	40.47	35.98	4.49	54	-13.53	299	57	Average
2389.02	51.8	47.31	4.49	74	-22.2	299	57	Peak
2457	89.87	85.25	4.62			299	57	Average
2457	96.4	91.78	4.62			299	57	Peak
2483.52	47.33	42.67	4.66	54	-6.67	299	57	Average
2483.52	55.32	50.66	4.66	74	-18.68	299	57	Peak
4914	41.61	31.46	10.15	54	-12.39	176	66	Average
4914	48.64	38.49	10.15	74	-25.36	176	66	Peak
Antenna Polarity & Test Distance: Vertical at 3 m								
Frequency (MHz)	Emission Level (dBuV/m)	Read Level (dBuV)	Factor (dB/m)	Limit (dBuV/m)	Margin (dB)	Antenna Height (cm)	Table Angle (Degree)	Remark
2387.94	40.85	36.36	4.49	54	-13.15	273	345	Average
2387.94	52.21	47.72	4.49	74	-21.79	273	345	Peak
2457	94.37	89.75	4.62			273	345	Average
2457	101.23	96.61	4.62			273	345	Peak
2483.56	52.89	48.23	4.66	54	-1.11	273	345	Average
2483.56	64.17	59.51	4.66	74	-9.83	273	345	Peak
4914	41.89	31.74	10.15	54	-12.11	154	255	Average
4914	48.49	38.34	10.15	74	-25.51	154	255	Peak

Remarks:

- Emission Level = Read Level + Factor  
Margin value = Emission level – Limit value
- 2457 MHz: Fundamental frequency.
- The emission levels of other frequencies were very low against the limit.

EUT Test Condition		Measurement Detail	
Channel	Channel 11	Frequency Range	1 GHz ~ 25 GHz
Input Power	120 Vac, 60 Hz	Detector Function	Peak (PK) Average (AV)
Environmental Conditions	25 deg. C, 65 % RH	Tested By	Charles Hsiao

Antenna Polarity & Test Distance: Horizontal at 3 m								
Frequency (MHz)	Emission Level (dBuV/m)	Read Level (dBuV)	Factor (dB/m)	Limit (dBuV/m)	Margin (dB)	Antenna Height (cm)	Table Angle (Degree)	Remark
2385.06	40.55	36.08	4.47	54	-13.45	299	57	Average
2385.06	51.91	47.44	4.47	74	-22.09	299	57	Peak
2462	90.8	86.18	4.62			299	57	Average
2462	97.45	92.83	4.62			299	57	Peak
2483.56	45.47	40.81	4.66	54	-8.53	299	57	Average
2483.56	56.4	51.74	4.66	74	-17.6	299	57	Peak
4924	41.77	31.52	10.25	54	-12.23	156	186	Average
4924	48.9	38.65	10.25	74	-25.1	156	186	Peak

Antenna Polarity & Test Distance: Vertical at 3 m								
Frequency (MHz)	Emission Level (dBuV/m)	Read Level (dBuV)	Factor (dB/m)	Limit (dBuV/m)	Margin (dB)	Antenna Height (cm)	Table Angle (Degree)	Remark
2387.76	41.04	36.55	4.49	54	-12.96	273	345	Average
2387.76	52.51	48.02	4.49	74	-21.49	273	345	Peak
2462	95.85	91.23	4.62			273	345	Average
2462	102.2	97.58	4.62			273	345	Peak
2483.52	52.32	47.66	4.66	54	-1.68	273	345	Average
2483.52	66.02	61.36	4.66	74	-7.98	273	345	Peak
4924	41.92	31.67	10.25	54	-12.08	178	54	Average
4924	48.29	38.04	10.25	74	-25.71	178	54	Peak

Remarks:

- Emission Level = Read Level + Factor  
Margin value = Emission level – Limit value
- 2462 MHz: Fundamental frequency.
- The emission levels of other frequencies were very low against the limit.

**802.11ax (HE20)**

EUT Test Condition		Measurement Detail	
Channel	Channel 1	Frequency Range	1 GHz ~ 25 GHz
Input Power	120 Vac, 60 Hz	Detector Function	Peak (PK) Average (AV)
Environmental Conditions	25 deg. C, 65 % RH	Tested By	Charles Hsiao

Antenna Polarity & Test Distance: Horizontal at 3 m								
Frequency (MHz)	Emission Level (dBuV/m)	Read Level (dBuV)	Factor (dB/m)	Limit (dBuV/m)	Margin (dB)	Antenna Height (cm)	Table Angle (Degree)	Remark
2389.74	47.55	43.06	4.49	54	-6.45	299	57	Average
2389.74	58.16	53.67	4.49	74	-15.84	299	57	Peak
2412	97.67	93.12	4.55			299	57	Average
2412	104.53	99.98	4.55			299	57	Peak
4824	41.88	31.59	10.29	54	-12.12	187	188	Average
4824	48.44	38.15	10.29	74	-25.56	187	188	Peak
Antenna Polarity & Test Distance: Vertical at 3 m								
Frequency (MHz)	Emission Level (dBuV/m)	Read Level (dBuV)	Factor (dB/m)	Limit (dBuV/m)	Margin (dB)	Antenna Height (cm)	Table Angle (Degree)	Remark
2389.92	51.54	47.04	4.5	54	-2.46	273	345	Average
2389.92	61.95	57.45	4.5	74	-12.05	273	345	Peak
2412	102.37	97.82	4.55			273	345	Average
2412	109.77	105.22	4.55			273	345	Peak
4824	41.64	31.35	10.29	54	-12.36	164	222	Average
4824	48.95	38.66	10.29	74	-25.05	164	222	Peak

Remarks:

- Emission Level = Read Level + Factor  
Margin value = Emission level – Limit value
- 2412 MHz: Fundamental frequency.
- The emission levels of other frequencies were very low against the limit.

EUT Test Condition		Measurement Detail	
Channel	Channel 6	Frequency Range	1 GHz ~ 25 GHz
Input Power	120 Vac, 60 Hz	Detector Function	Peak (PK) Average (AV)
Environmental Conditions	25 deg. C, 65 % RH	Tested By	Charles Hsiao

Antenna Polarity & Test Distance: Horizontal at 3 m								
Frequency (MHz)	Emission Level (dBuV/m)	Read Level (dBuV)	Factor (dB/m)	Limit (dBuV/m)	Margin (dB)	Antenna Height (cm)	Table Angle (Degree)	Remark
2389.74	41.31	36.82	4.49	54	-12.69	299	57	Average
2389.74	52.05	47.56	4.49	74	-21.95	299	57	Peak
2437	99.25	94.66	4.59			299	57	Average
2437	106.27	101.68	4.59			299	57	Peak
2483.64	41.13	36.47	4.66	54	-12.87	299	57	Average
2483.64	52.16	47.5	4.66	74	-21.84	299	57	Peak
4874	41.67	31.46	10.21	54	-12.33	177	209	Average
4874	47.96	37.75	10.21	74	-26.04	177	209	Peak

Antenna Polarity & Test Distance: Vertical at 3 m								
Frequency (MHz)	Emission Level (dBuV/m)	Read Level (dBuV)	Factor (dB/m)	Limit (dBuV/m)	Margin (dB)	Antenna Height (cm)	Table Angle (Degree)	Remark
2389.83	43.58	39.08	4.5	54	-10.42	273	345	Average
2389.83	55.25	50.75	4.5	74	-18.75	273	345	Peak
2437	103.35	98.76	4.59			273	345	Average
2437	110.58	105.99	4.59			273	345	Peak
2483.52	42.42	37.76	4.66	54	-11.58	273	345	Average
2483.52	53.83	49.17	4.66	74	-20.17	273	345	Peak
4874	41.82	31.61	10.21	54	-12.18	159	208	Average
4874	48.69	38.48	10.21	74	-25.31	159	208	Peak

Remarks:

- Emission Level = Read Level + Factor  
Margin value = Emission level – Limit value
- 2437 MHz: Fundamental frequency.
- The emission levels of other frequencies were very low against the limit.

EUT Test Condition		Measurement Detail	
Channel	Channel 11	Frequency Range	1 GHz ~ 25 GHz
Input Power	120 Vac, 60 Hz	Detector Function	Peak (PK) Average (AV)
Environmental Conditions	25 deg. C, 65 % RH	Tested By	Charles Hsiao

Antenna Polarity & Test Distance: Horizontal at 3 m								
Frequency (MHz)	Emission Level (dBuV/m)	Read Level (dBuV)	Factor (dB/m)	Limit (dBuV/m)	Margin (dB)	Antenna Height (cm)	Table Angle (Degree)	Remark
2462	98.8	94.18	4.62			299	57	Average
2462	105.82	101.2	4.62			299	57	Peak
2483.68	47.74	43.08	4.66	54	-6.26	299	57	Average
2483.68	61.59	56.93	4.66	74	-12.41	299	57	Peak
4924	41.75	31.5	10.25	54	-12.25	145	178	Average
4924	48.57	38.32	10.25	74	-25.43	145	178	Peak
Antenna Polarity & Test Distance: Vertical at 3 m								
Frequency (MHz)	Emission Level (dBuV/m)	Read Level (dBuV)	Factor (dB/m)	Limit (dBuV/m)	Margin (dB)	Antenna Height (cm)	Table Angle (Degree)	Remark
2462	103.65	99.03	4.62			273	345	Average
2462	110.46	105.84	4.62			273	345	Peak
2483.76	52.62	47.96	4.66	54	-1.38	273	345	Average
2483.76	64.87	60.21	4.66	74	-9.13	273	345	Peak
4924	41.87	31.62	10.25	54	-12.13	133	286	Average
4924	49.29	39.04	10.25	74	-24.71	133	286	Peak

Remarks:

- Emission Level = Read Level + Factor  
Margin value = Emission level – Limit value
- 2462 MHz: Fundamental frequency.
- The emission levels of other frequencies were very low against the limit.



EUT Test Condition		Measurement Detail	
Channel	Channel 12	Frequency Range	1 GHz ~ 25 GHz
Input Power	120 Vac, 60 Hz	Detector Function	Peak (PK) Average (AV)
Environmental Conditions	25 deg. C, 65 % RH	Tested By	Charles Hsiao

Antenna Polarity & Test Distance: Horizontal at 3 m								
Frequency (MHz)	Emission Level (dBuV/m)	Read Level (dBuV)	Factor (dB/m)	Limit (dBuV/m)	Margin (dB)	Antenna Height (cm)	Table Angle (Degree)	Remark
2467	96.55	91.92	4.63			299	57	Average
2467	103.61	98.98	4.63			299	57	Peak
2483.52	47.31	42.65	4.66	54	-6.69	299	57	Average
2483.52	58.82	54.16	4.66	74	-15.18	299	57	Peak
4934	41.74	31.48	10.26	54	-12.26	108	34	Average
4934	48.31	38.05	10.26	74	-25.69	108	34	Peak
Antenna Polarity & Test Distance: Vertical at 3 m								
Frequency (MHz)	Emission Level (dBuV/m)	Read Level (dBuV)	Factor (dB/m)	Limit (dBuV/m)	Margin (dB)	Antenna Height (cm)	Table Angle (Degree)	Remark
2467	101.54	96.91	4.63			273	345	Average
2467	108.17	103.54	4.63			273	345	Peak
2483.52	52.59	47.93	4.66	54	-1.41	273	345	Average
2483.52	64.26	59.6	4.66	74	-9.74	273	345	Peak
4934	41.95	31.69	10.26	54	-12.05	118	249	Average
4934	49.94	39.68	10.26	74	-24.06	118	249	Peak

Remarks:

- Emission Level = Read Level + Factor  
Margin value = Emission level – Limit value
- 2467 MHz: Fundamental frequency.
- The emission levels of other frequencies were very low against the limit.

EUT Test Condition		Measurement Detail	
Channel	Channel 13	Frequency Range	1 GHz ~ 25 GHz
Input Power	120 Vac, 60 Hz	Detector Function	Peak (PK) Average (AV)
Environmental Conditions	25 deg. C, 65 % RH	Tested By	Charles Hsiao

Antenna Polarity & Test Distance: Horizontal at 3 m								
Frequency (MHz)	Emission Level (dBuV/m)	Read Level (dBuV)	Factor (dB/m)	Limit (dBuV/m)	Margin (dB)	Antenna Height (cm)	Table Angle (Degree)	Remark
2472	92.55	87.91	4.64			299	57	Average
2472	99.24	94.6	4.64			299	57	Peak
2483.52	43.21	38.55	4.66	54	-10.79	299	57	Average
2483.52	65.52	60.86	4.66	74	-8.48	299	57	Peak
4944	41.81	31.46	10.35	54	-12.19	155	175	Average
4944	48.36	38.01	10.35	74	-25.64	155	175	Peak
Antenna Polarity & Test Distance: Vertical at 3 m								
Frequency (MHz)	Emission Level (dBuV/m)	Read Level (dBuV)	Factor (dB/m)	Limit (dBuV/m)	Margin (dB)	Antenna Height (cm)	Table Angle (Degree)	Remark
2472	97.55	92.91	4.64			273	345	Average
2472	104.05	99.41	4.64			273	345	Peak
2486.28	53	48.34	4.66	54	-1	273	345	Average
2486.28	71.67	67.01	4.66	74	-2.33	273	345	Peak
4944	41.77	31.42	10.35	54	-12.23	173	155	Average
4944	48.46	38.11	10.35	74	-25.54	173	155	Peak

Remarks:

- Emission Level = Read Level + Factor  
Margin value = Emission level – Limit value
- 2472 MHz: Fundamental frequency.
- The emission levels of other frequencies were very low against the limit.

**802.11ax (HE40)**

EUT Test Condition		Measurement Detail	
Channel	Channel 3	Frequency Range	1 GHz ~ 25 GHz
Input Power	120 Vac, 60 Hz	Detector Function	Peak (PK) Average (AV)
Environmental Conditions	25 deg. C, 65 % RH	Tested By	Charles Hsiao

Antenna Polarity & Test Distance: Horizontal at 3 m								
Frequency (MHz)	Emission Level (dBuV/m)	Read Level (dBuV)	Factor (dB/m)	Limit (dBuV/m)	Margin (dB)	Antenna Height (cm)	Table Angle (Degree)	Remark
2389.29	46.1	41.61	4.49	54	-7.9	299	57	Average
2389.29	56.44	51.95	4.49	74	-17.56	299	57	Peak
2422	95.42	90.86	4.56			299	57	Average
2422	102.83	98.27	4.56			299	57	Peak
2493.84	41.15	36.48	4.67	54	-12.85	299	57	Average
2493.84	52.46	47.79	4.67	74	-21.54	299	57	Peak
4844	42.19	31.96	10.23	54	-11.81	164	153	Average
4844	48.88	38.65	10.23	74	-25.12	164	153	Peak
Antenna Polarity & Test Distance: Vertical at 3 m								
Frequency (MHz)	Emission Level (dBuV/m)	Read Level (dBuV)	Factor (dB/m)	Limit (dBuV/m)	Margin (dB)	Antenna Height (cm)	Table Angle (Degree)	Remark
2389.74	52.19	47.7	4.49	54	-1.81	273	345	Average
2389.74	61.23	56.74	4.49	74	-12.77	273	345	Peak
2422	100.47	95.91	4.56			273	345	Average
2422	107.36	102.8	4.56			273	345	Peak
2484.16	41.99	37.33	4.66	54	-12.01	273	345	Average
2484.16	53.21	48.55	4.66	74	-20.79	273	345	Peak
4844	42.1	31.87	10.23	54	-11.9	159	245	Average
4844	48.39	38.16	10.23	74	-25.61	159	245	Peak

Remarks:

- Emission Level = Read Level + Factor  
Margin value = Emission level – Limit value
- 2422 MHz: Fundamental frequency.
- The emission levels of other frequencies were very low against the limit.

EUT Test Condition		Measurement Detail	
Channel	Channel 6	Frequency Range	1 GHz ~ 25 GHz
Input Power	120 Vac, 60 Hz	Detector Function	Peak (PK) Average (AV)
Environmental Conditions	25 deg. C, 65 % RH	Tested By	Charles Hsiao

Antenna Polarity & Test Distance: Horizontal at 3 m								
Frequency (MHz)	Emission Level (dBuV/m)	Read Level (dBuV)	Factor (dB/m)	Limit (dBuV/m)	Margin (dB)	Antenna Height (cm)	Table Angle (Degree)	Remark
2389.74	46.28	41.79	4.49	54	-7.72	299	57	Average
2389.74	55.58	51.09	4.49	74	-18.42	299	57	Peak
2437	97.45	92.86	4.59			299	57	Average
2437	104	99.41	4.59			299	57	Peak
2483.52	42.89	38.23	4.66	54	-11.11	299	57	Average
2483.52	55.07	50.41	4.66	74	-18.93	299	57	Peak
4874	41.98	31.77	10.21	54	-12.02	189	208	Average
4874	48.74	38.53	10.21	74	-25.26	189	208	Peak

Antenna Polarity & Test Distance: Vertical at 3 m								
Frequency (MHz)	Emission Level (dBuV/m)	Read Level (dBuV)	Factor (dB/m)	Limit (dBuV/m)	Margin (dB)	Antenna Height (cm)	Table Angle (Degree)	Remark
2389.92	52.87	48.37	4.5	54	-1.13	273	345	Average
2389.92	63.23	58.73	4.5	74	-10.77	273	345	Peak
2437	102.35	97.76	4.59			273	345	Average
2437	109.48	104.89	4.59			273	345	Peak
2483.72	49.84	45.18	4.66	54	-4.16	273	345	Average
2483.72	60.33	55.67	4.66	74	-13.67	273	345	Peak
4874	41.87	31.66	10.21	54	-12.13	184	277	Average
4874	47.84	37.63	10.21	74	-26.16	184	277	Peak

Remarks:

- Emission Level = Read Level + Factor  
Margin value = Emission level – Limit value
- 2437 MHz: Fundamental frequency.
- The emission levels of other frequencies were very low against the limit.

EUT Test Condition		Measurement Detail	
Channel	Channel 9	Frequency Range	1 GHz ~ 25 GHz
Input Power	120 Vac, 60 Hz	Detector Function	Peak (PK) Average (AV)
Environmental Conditions	25 deg. C, 65 % RH	Tested By	Charles Hsiao

Antenna Polarity & Test Distance: Horizontal at 3 m								
Frequency (MHz)	Emission Level (dBuV/m)	Read Level (dBuV)	Factor (dB/m)	Limit (dBuV/m)	Margin (dB)	Antenna Height (cm)	Table Angle (Degree)	Remark
2389.47	41.5	37.01	4.49	54	-12.5	299	57	Average
2389.47	52.64	48.15	4.49	74	-21.36	299	57	Peak
2452	95.87	91.27	4.6			299	57	Average
2452	102.74	98.14	4.6			299	57	Peak
2483.52	44.51	39.85	4.66	54	-9.49	299	57	Average
2483.52	54.95	50.29	4.66	74	-19.05	299	57	Peak
4904	42.02	31.88	10.14	54	-11.98	129	8	Average
4904	48.14	38	10.14	74	-25.86	129	8	Peak

Antenna Polarity & Test Distance: Vertical at 3 m								
Frequency (MHz)	Emission Level (dBuV/m)	Read Level (dBuV)	Factor (dB/m)	Limit (dBuV/m)	Margin (dB)	Antenna Height (cm)	Table Angle (Degree)	Remark
2389.56	43.4	38.91	4.49	54	-10.6	273	345	Average
2389.56	54.05	49.56	4.49	74	-19.95	273	345	Peak
2452	100.67	96.07	4.6			273	345	Average
2452	107.82	103.22	4.6			273	345	Peak
2483.76	52.51	47.85	4.66	54	-1.49	273	345	Average
2483.76	63.06	58.4	4.66	74	-10.94	273	345	Peak
4904	41.9	31.76	10.14	54	-12.1	144	316	Average
4904	48.14	38	10.14	74	-25.86	144	316	Peak

Remarks:

1. Emission Level = Read Level + Factor  
Margin value = Emission level – Limit value
2. 2452 MHz: Fundamental frequency.
3. The emission levels of other frequencies were very low against the limit.

EUT Test Condition		Measurement Detail	
Channel	Channel 10	Frequency Range	1 GHz ~ 25 GHz
Input Power	120 Vac, 60 Hz	Detector Function	Peak (PK) Average (AV)
Environmental Conditions	25 deg. C, 65 % RH	Tested By	Charles Hsiao

Antenna Polarity & Test Distance: Horizontal at 3 m								
Frequency (MHz)	Emission Level (dBuV/m)	Read Level (dBuV)	Factor (dB/m)	Limit (dBuV/m)	Margin (dB)	Antenna Height (cm)	Table Angle (Degree)	Remark
2386.32	40.59	36.1	4.49	54	-13.41	299	57	Average
2386.32	51.32	46.83	4.49	74	-22.68	299	57	Peak
2457	87.49	82.87	4.62			299	57	Average
2457	94.55	89.93	4.62			299	57	Peak
2483.52	46.51	41.85	4.66	54	-7.49	299	57	Average
2483.52	56.19	51.53	4.66	74	-17.81	299	57	Peak
4914	42.07	31.92	10.15	54	-11.93	118	175	Average
4914	49.06	38.91	10.15	74	-24.94	118	175	Peak

Antenna Polarity & Test Distance: Vertical at 3 m								
Frequency (MHz)	Emission Level (dBuV/m)	Read Level (dBuV)	Factor (dB/m)	Limit (dBuV/m)	Margin (dB)	Antenna Height (cm)	Table Angle (Degree)	Remark
2387.76	40.85	36.36	4.49	54	-13.15	273	345	Average
2387.76	51.8	47.31	4.49	74	-22.2	273	345	Peak
2457	92.47	87.85	4.62			273	345	Average
2457	99.7	95.08	4.62			273	345	Peak
2483.56	52.92	48.26	4.66	54	-1.08	273	345	Average
2483.56	63.63	58.97	4.66	74	-10.37	273	345	Peak
4914	41.84	31.69	10.15	54	-12.16	164	251	Average
4914	49.02	38.87	10.15	74	-24.98	164	251	Peak

Remarks:

- Emission Level = Read Level + Factor  
Margin value = Emission level – Limit value
- 2457 MHz: Fundamental frequency.
- The emission levels of other frequencies were very low against the limit.

EUT Test Condition		Measurement Detail	
Channel	Channel 11	Frequency Range	1 GHz ~ 25 GHz
Input Power	120 Vac, 60 Hz	Detector Function	Peak (PK) Average (AV)
Environmental Conditions	25 deg. C, 65 % RH	Tested By	Charles Hsiao

Antenna Polarity & Test Distance: Horizontal at 3 m								
Frequency (MHz)	Emission Level (dBuV/m)	Read Level (dBuV)	Factor (dB/m)	Limit (dBuV/m)	Margin (dB)	Antenna Height (cm)	Table Angle (Degree)	Remark
2382.72	40.57	36.1	4.47	54	-13.43	299	57	Average
2382.72	52.5	48.03	4.47	74	-21.5	299	57	Peak
2462	90.33	85.71	4.62			299	57	Average
2462	97.27	92.65	4.62			299	57	Peak
2483.68	45.05	40.39	4.66	54	-8.95	299	57	Average
2483.68	61.64	56.98	4.66	74	-12.36	299	57	Peak
4924	42.11	31.86	10.25	54	-11.89	118	148	Average
4924	48.07	37.82	10.25	74	-25.93	118	148	Peak

Antenna Polarity & Test Distance: Vertical at 3 m								
Frequency (MHz)	Emission Level (dBuV/m)	Read Level (dBuV)	Factor (dB/m)	Limit (dBuV/m)	Margin (dB)	Antenna Height (cm)	Table Angle (Degree)	Remark
2389.74	41.12	36.63	4.49	54	-12.88	273	345	Average
2389.74	54.27	49.78	4.49	74	-19.73	273	345	Peak
2462	95.79	91.17	4.62			273	345	Average
2462	102.54	97.92	4.62			273	345	Peak
2483.52	52.52	47.86	4.66	54	-1.48	273	345	Average
2483.52	66.74	62.08	4.66	74	-7.26	273	345	Peak
4924	41.97	31.72	10.25	54	-12.03	164	166	Average
4924	48.38	38.13	10.25	74	-25.62	164	166	Peak

Remarks:

- Emission Level = Read Level + Factor  
Margin value = Emission level – Limit value
- 2462 MHz: Fundamental frequency.
- The emission levels of other frequencies were very low against the limit.

**9 kHz ~ 30 MHz Data:**

The amplitude of spurious emissions attenuated more than 20 dB below the permissible value is not required to be report.

**30 MHz ~ 1 GHz Worst-Case Data:**

**802.11ax (HE20)**

EUT Test Condition		Measurement Detail	
Channel	Channel 13	Frequency Range	30 MHz ~ 1 GHz
Input Power	120 Vac, 60 Hz	Detector Function	Peak (PK) Quasi-peak (QP)
Environmental Conditions	25 deg. C, 65 % RH	Tested By	Karl Lee

**Horizontal**

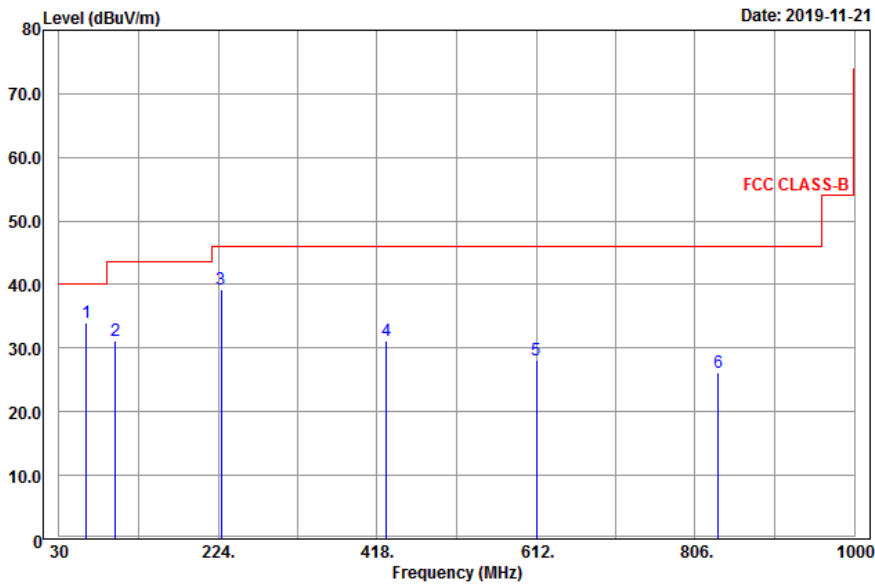

**Vertical**

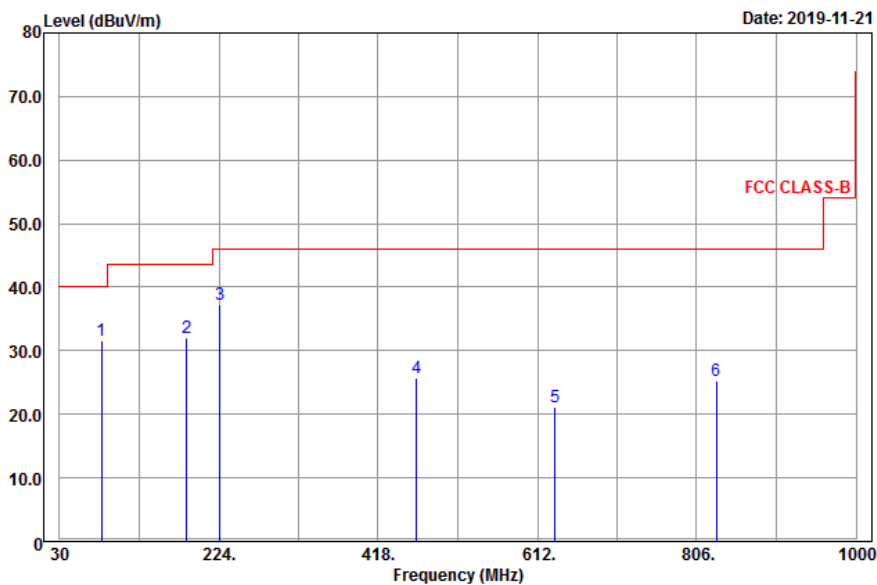



**Antenna Polarity & Test Distance: Horizontal at 3 m**

Frequency (MHz)	Emission Level (dBuV/m)	Read Level (dBuV)	Factor (dB/m)	Limit (dBuV/m)	Margin (dB)	Antenna Height (cm)	Table Angle (Degree)	Remark
63.48	33.98	51.22	-17.24	40	-6.02	150	253	Peak
98.58	31.08	48.41	-17.33	43.5	-12.42	182	115	Peak
227.91	39.23	56.71	-17.48	46	-6.77	167	269	Peak
429.5	31.14	44.67	-13.53	46	-14.86	107	241	Peak
612.2	28.1	38.54	-10.44	46	-17.9	129	359	Peak
834.1	26.23	33.25	-7.02	46	-19.77	144	251	Peak

**Antenna Polarity & Test Distance: Vertical at 3 m**

Frequency (MHz)	Emission Level (dBuV/m)	Read Level (dBuV)	Factor (dB/m)	Limit (dBuV/m)	Margin (dB)	Antenna Height (cm)	Table Angle (Degree)	Remark
81.3	31.57	52.73	-21.16	40	-8.43	118	346	Peak
184.71	32.13	51.37	-19.24	43.5	-11.37	139	122	Peak
225.21	37.24	54.86	-17.62	46	-8.76	170	51	Peak
464.5	25.62	38.67	-13.05	46	-20.38	157	21	Peak
633.2	21.19	31.55	-10.36	46	-24.81	145	86	Peak
829.9	25.2	32.25	-7.05	46	-20.8	190	232	Peak

Remarks:

- Emission Level = Read Level + Factor  
Margin value = Emission level – Limit value.
- The emission levels of other frequencies were very low against the limit.

## 4.2 Conducted Emission Measurement

### 4.2.1 Limits of Conducted Emission Measurement

Frequency (MHz)	Conducted Limit (dBuV)	
	Quasi-Peak	Average
0.15 - 0.5	66 - 56	56 - 46
0.50 - 5.0	56	46
5.0 - 30.0	60	50

- Note: 1. The lower limit shall apply at the transition frequencies.  
 2. The limit decreases in line with the logarithm of the frequency in the range of 0.15 to 0.50 MHz.

### 4.2.2 Test Instruments

Description & Manufacturer	Model No.	Serial No.	Date of Calibration	Due Date of Calibration
Test Receiver ROHDE & SCHWARZ	ESCI	100613	Dec. 10, 2018	Dec. 09, 2019
RF signal cable (with 10dB PAD) Woken	5D-FB	Cable-cond1-01	Sep. 05, 2019	Sep. 04, 2020
LISN ROHDE & SCHWARZ (EUT)	ENV216	101826	Feb. 21, 2019	Feb. 20, 2020
LISN ROHDE & SCHWARZ (Peripheral)	ESH3-Z5	100311	Aug. 22, 2019	Aug. 21, 2020
Software ADT	BV ADT_Cond_ V7.3.7.4	NA	NA	NA

- Note: 1. The calibration interval of the above test instruments is 12 months and the calibrations are traceable to NML/ROC and NIST/USA.  
 2. The test was performed in HwaYa Shielded Room 1.  
 3. The VCCI Site Registration No. is C-12040.

#### 4.2.3 Test Procedures

- a. The EUT was placed 0.4 meters from the conducting wall of the shielded room with EUT being connected to the power mains through a line impedance stabilization network (LISN). Other support units were connected to the power mains through another LISN. The two LISNs provide 50 ohm/50 uH of coupling impedance for the measuring instrument.
- b. Both lines of the power mains connected to the EUT were checked for maximum conducted interference.
- c. The frequency range from 150 kHz to 30 MHz was searched. Emission levels under (Limit – 20 dB) was not recorded.

**Note:** The resolution bandwidth and video bandwidth of test receiver is 9 kHz for quasi-peak detection (QP) and average detection (AV) at frequency 0.15 MHz – 30 MHz.

#### 4.2.4 Deviation from Test Standard

No deviation.

#### 4.2.5 Test Setup

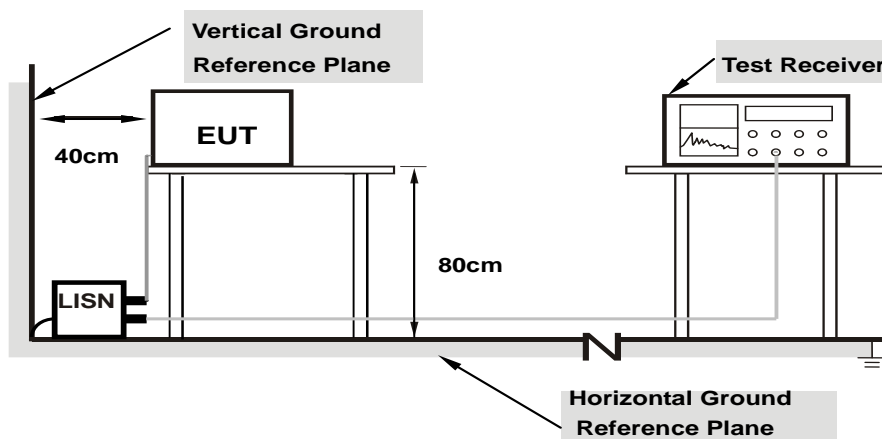

**Note:** 1.Support units were connected to second LISN.

For the actual test configuration, please refer to the attached file (Test Setup Photo).

#### 4.2.6 EUT Operating Conditions

- a. Placed the EUT on a testing table.
- b. Use the software to control the EUT under transmission condition continuously at specific channel frequency.

#### 4.2.7 Test Results

Frequency Range	150kHz ~ 30MHz	Detector Function & Resolution Bandwidth	Quasi-Peak (QP) / Average (AV), 9kHz
Input Power	120Vac, 60Hz	Environmental Conditions	25°C, 65%RH
Tested by	Jisyong Wang	Test Date	2019/11/24

Phase Of Power : Line (L)										
No	Frequency (MHz)	Correction Factor (dB)	Reading Value (dBuV)		Emission Level (dBuV)		Limit (dBuV)		Margin (dB)	
			Q.P.	AV.	Q.P.	AV.	Q.P.	AV.	Q.P.	AV.
1	0.18519	9.66	34.99	30.47	44.65	40.13	64.25	54.25	-19.60	-14.12
2	0.46200	9.69	26.98	21.99	36.67	31.68	56.66	46.66	-19.99	-14.98
3	0.62200	9.70	26.53	21.12	36.23	30.82	56.00	46.00	-19.77	-15.18
4	1.03400	9.73	26.50	21.79	36.23	31.52	56.00	46.00	-19.77	-14.48
5	3.45782	9.82	22.67	19.73	32.49	29.55	56.00	46.00	-23.51	-16.45
6	12.80600	9.95	26.78	20.25	36.73	30.20	60.00	50.00	-23.27	-19.80

Remarks:

1. Q.P. and AV. are abbreviations of quasi-peak and average individually.
2. The emission levels of other frequencies were very low against the limit.
3. Margin value = Emission level – Limit value
4. Correction factor = Insertion loss + Cable loss
5. Emission Level = Correction Factor + Reading Value

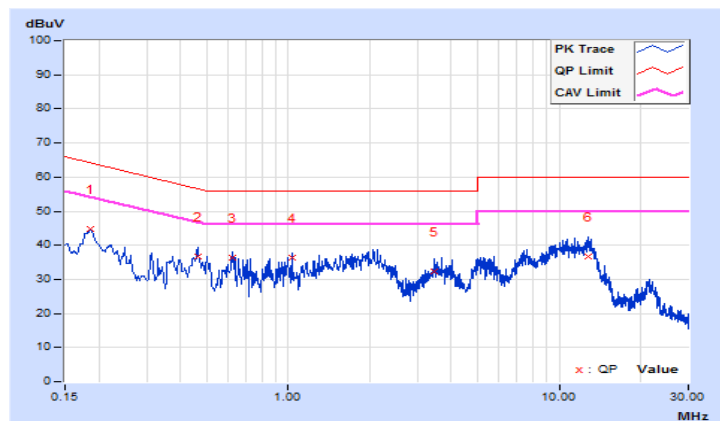

Frequency Range	150kHz ~ 30MHz	Detector Function & Resolution Bandwidth	Quasi-Peak (QP) / Average (AV), 9kHz
Input Power	120Vac, 60Hz	Environmental Conditions	25°C, 65%RH
Tested by	Jisyong Wang	Test Date	2019/11/24

Phase Of Power : Neutral (N)										
No	Frequency (MHz)	Correction Factor (dB)	Reading Value (dBuV)		Emission Level (dBuV)		Limit (dBuV)		Margin (dB)	
			Q.P.	AV.	Q.P.	AV.	Q.P.	AV.	Q.P.	AV.
1	0.16932	9.64	38.14	31.95	47.78	41.59	64.99	54.99	-17.21	-13.40
2	0.21400	9.64	31.48	28.78	41.12	38.42	63.05	53.05	-21.93	-14.63
3	0.31365	9.65	30.70	25.28	40.35	34.93	59.87	49.87	-19.52	-14.94
<b>4</b>	<b>0.36200</b>	<b>9.66</b>	<b>30.27</b>	<b>27.97</b>	<b>39.93</b>	<b>37.63</b>	<b>58.68</b>	<b>48.68</b>	<b>-18.75</b>	<b>-11.05</b>
5	5.11000	9.83	21.43	16.83	31.26	26.66	60.00	50.00	-28.74	-23.34
6	12.94200	9.96	23.79	18.66	33.75	28.62	60.00	50.00	-26.25	-21.38

Remarks:

1. Q.P. and AV. are abbreviations of quasi-peak and average individually.
2. The emission levels of other frequencies were very low against the limit.
3. Margin value = Emission level – Limit value
4. Correction factor = Insertion loss + Cable loss
5. Emission Level = Correction Factor + Reading Value

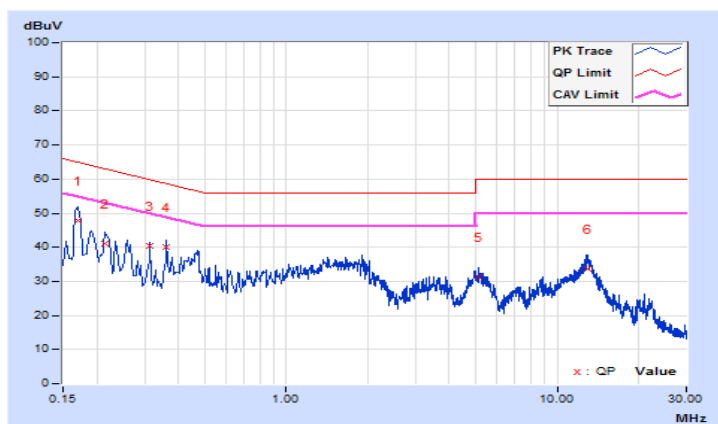

### 4.3 6 dB Bandwidth Measurement

#### 4.3.1 Limits of 6 dB Bandwidth Measurement

The minimum of 6 dB Bandwidth Measurement is 0.5 MHz.

#### 4.3.2 Test Setup

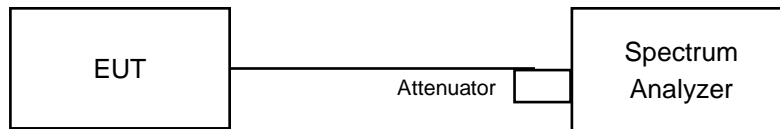

#### 4.3.3 Test Instruments

Refer to section 4.1.2 to get information of above instrument.

#### 4.3.4 Test Procedure

- Set resolution bandwidth (RBW) = 100 kHz
- Set the video bandwidth (VBW)  $\geq 3 \times$  RBW, Detector = Peak.
- Trace mode = max hold.
- Sweep = auto couple.
- Measure the maximum width of the emission that is constrained by the frequencies associated with the two amplitude points (upper and lower) that are attenuated by 6 dB relative to the maximum level measured in the fundamental emission

#### 4.3.5 Deviation from Test Standard

No deviation.

#### 4.3.6 EUT Operating Conditions

The software provided by client to enable the EUT under transmission condition continuously at lowest, middle and highest channel frequencies individually.

## 4.3.7 Test Results

## 802.11b

Channel	Frequency (MHz)	6 dB Bandwidth (MHz)	Minimum Limit (MHz)	Pass / Fail
1	2412	8.07	0.5	Pass
6	2437	8.06	0.5	Pass
11	2462	8.08	0.5	Pass
12	2467	9.59	0.5	Pass
13	2472	9.11	0.5	Pass

## 802.11g

Channel	Frequency (MHz)	6 dB Bandwidth (MHz)	Minimum Limit (MHz)	Pass / Fail
1	2412	16.39	0.5	Pass
6	2437	16.37	0.5	Pass
11	2462	16.41	0.5	Pass
12	2467	16.39	0.5	Pass
13	2472	16.40	0.5	Pass

## 802.11n (HT20)

Channel	Frequency (MHz)	6 dB Bandwidth (MHz)		Minimum Limit (MHz)	Pass / Fail
		Chain 0	Chain 1		
1	2412	17.61	17.64	0.5	Pass
6	2437	17.65	17.65	0.5	Pass
11	2462	17.60	17.65	0.5	Pass
12	2467	17.63	17.66	0.5	Pass
13	2472	17.63	17.65	0.5	Pass

## 802.11n (HT40)

Channel	Frequency (MHz)	6 dB Bandwidth (MHz)		Minimum Limit (MHz)	Pass / Fail
		Chain 0	Chain 1		
3	2422	36.42	36.44	0.5	Pass
6	2437	36.39	36.46	0.5	Pass
9	2452	36.21	36.46	0.5	Pass
10	2457	36.06	36.43	0.5	Pass
11	2462	36.43	36.45	0.5	Pass

**802.11ax (HE20)**

Channel	Frequency (MHz)	6 dB Bandwidth (MHz)		Minimum Limit (MHz)	Pass / Fail
		Chain 0	Chain 1		
1	2412	18.92	18.94	0.5	Pass
6	2437	18.91	18.76	0.5	Pass
11	2462	18.96	18.83	0.5	Pass
12	2467	18.81	18.83	0.5	Pass
13	2472	19.02	18.97	0.5	Pass

**802.11ax (HE40)**

Channel	Frequency (MHz)	6 dB Bandwidth (MHz)		Minimum Limit (MHz)	Pass / Fail
		Chain 0	Chain 1		
3	2422	37.66	37.98	0.5	Pass
6	2437	37.93	37.88	0.5	Pass
9	2452	37.64	37.82	0.5	Pass
10	2457	37.86	37.77	0.5	Pass
11	2462	37.95	38.06	0.5	Pass



### Spectrum Plot of Worst Value

#### 802.11b

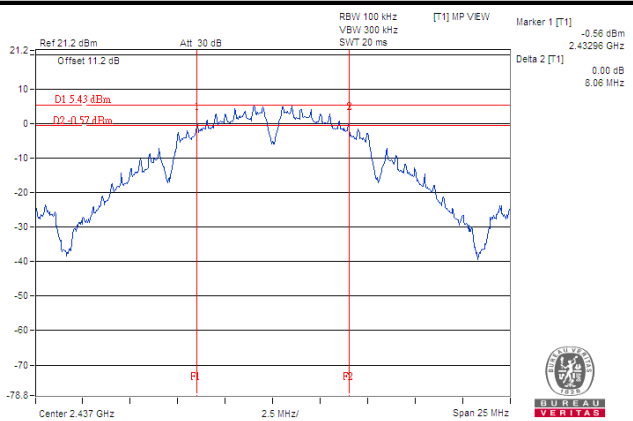

#### 802.11g

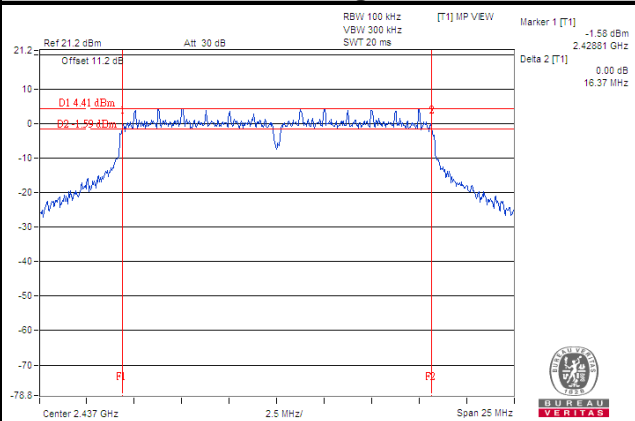

#### 802.11n (HT20)

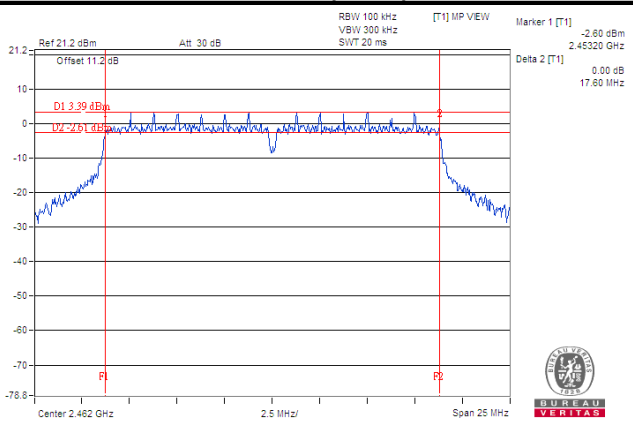

#### 802.11n (HT40)

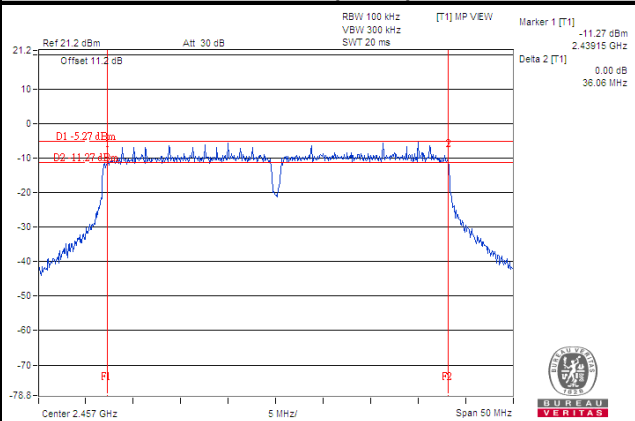

#### 802.11ax (HE20)

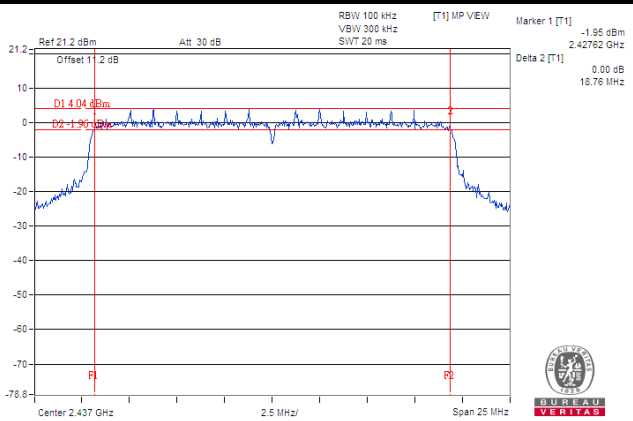

#### 802.11ax (HE40)

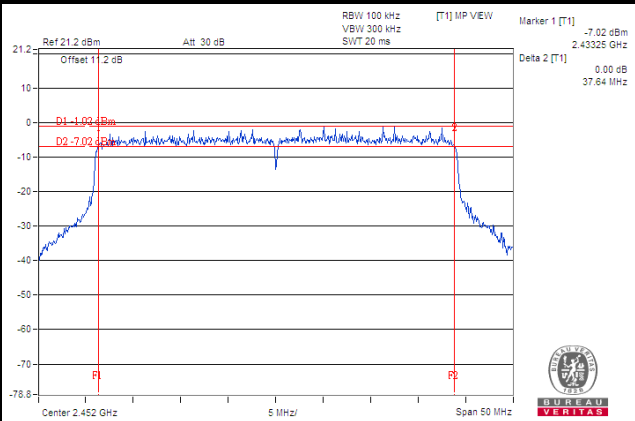

## 4.4 Occupied Bandwidth Measurement

### 4.4.1 Test Setup

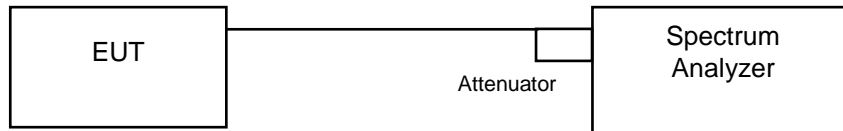

### 4.4.2 Test Instruments

Refer to section 4.1.2 to get information of above instrument.

### 4.4.3 Test Procedure

The transmitter output was connected to the spectrum analyzer through an attenuator. The bandwidth of the fundamental frequency was measured by spectrum analyzer with resolution bandwidth in the range of 1 % to 5 % of the anticipated emission bandwidth, and a video bandwidth at least 3x the resolution bandwidth and set the detector to sampling. The width of a frequency band such that, below the lower and above the upper frequency limits, the mean powers emitted are each equal to a specified percentage 0.5 % of the total mean power of a given emission.

### 4.4.4 Deviation from Test Standard

No deviation.

### 4.4.5 EUT Operating Conditions

The software provided by client to enable the EUT under transmission condition continuously at lowest, middle and highest channel frequencies individually.

#### 4.4.6 Test Results

##### 802.11b

Channel	Frequency (MHz)	Occupied Bandwidth (MHz)	Pass / Fail
1	2412	14.62	Pass
6	2437	14.43	Pass
11	2462	14.61	Pass
12	2467	15.29	Pass
13	2472	15.29	Pass

##### 802.11g

Channel	Frequency (MHz)	Occupied Bandwidth (MHz)	Pass / Fail
1	2412	17.11	Pass
6	2437	17.02	Pass
11	2462	17.02	Pass
12	2467	17.02	Pass
13	2472	16.83	Pass

##### 802.11n (HT20)

Channel	Frequency (MHz)	Occupied Bandwidth (MHz)		Pass / Fail
		Chain 0	Chain 1	
1	2412	18.08	17.98	Pass
6	2437	18.17	18.08	Pass
11	2462	18.17	18.07	Pass
12	2467	18.08	17.98	Pass
13	2472	17.98	17.88	Pass

##### 802.11n (HT40)

Channel	Frequency (MHz)	Occupied Bandwidth (MHz)		Pass / Fail
		Chain 0	Chain 1	
3	2422	36.83	36.83	Pass
6	2437	36.83	36.64	Pass
9	2452	36.83	36.83	Pass
10	2457	36.83	36.64	Pass
11	2462	36.64	36.74	Pass

**802.11ax (HE20)**

Channel	Frequency (MHz)	Occupied Bandwidth (MHz)		Pass / Fail
		Chain 0	Chain 1	
1	2412	19.24	19.14	Pass
6	2437	19.14	19.14	Pass
11	2462	19.24	19.24	Pass
12	2467	19.04	19.04	Pass
13	2472	19.04	19.14	Pass

**802.11ax (HE40)**

Channel	Frequency (MHz)	Occupied Bandwidth (MHz)		Pass / Fail
		Chain 0	Chain 1	
3	2422	38.17	38.17	Pass
6	2437	38.08	38.08	Pass
9	2452	38.26	38.27	Pass
10	2457	38.17	38.17	Pass
11	2462	38.17	38.17	Pass

Spectrum Plot of Worst Value

802.11b

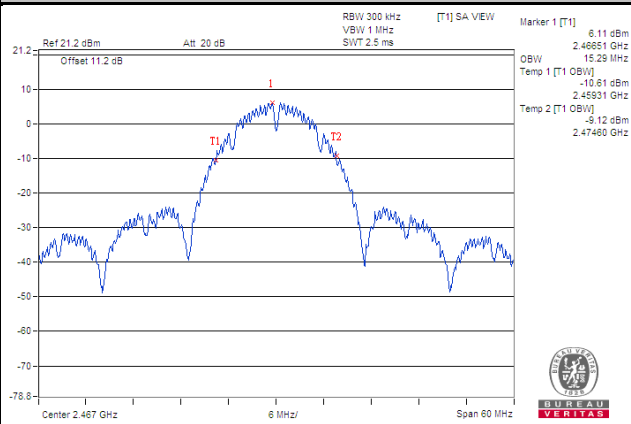

802.11g

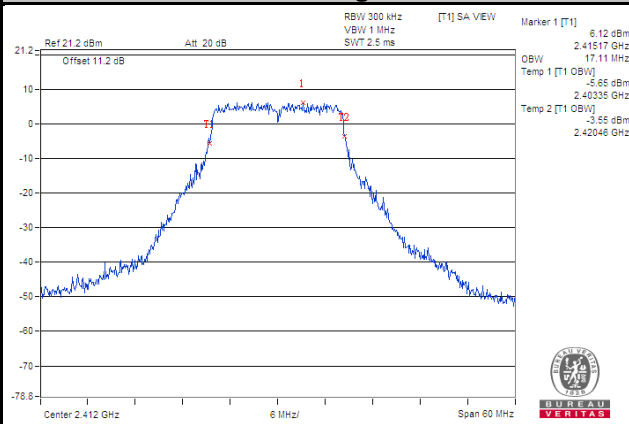

802.11n (HT20)

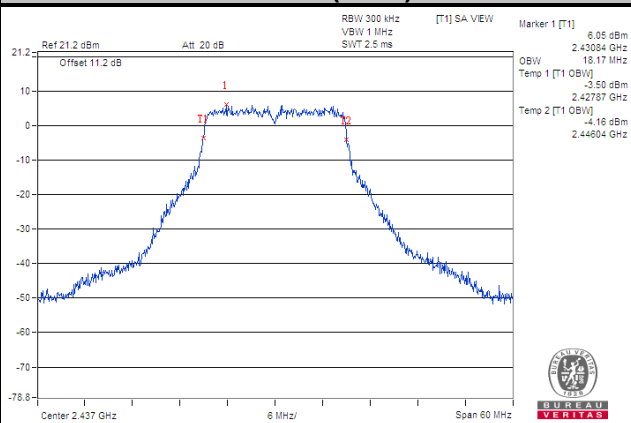

802.11n (HT40)

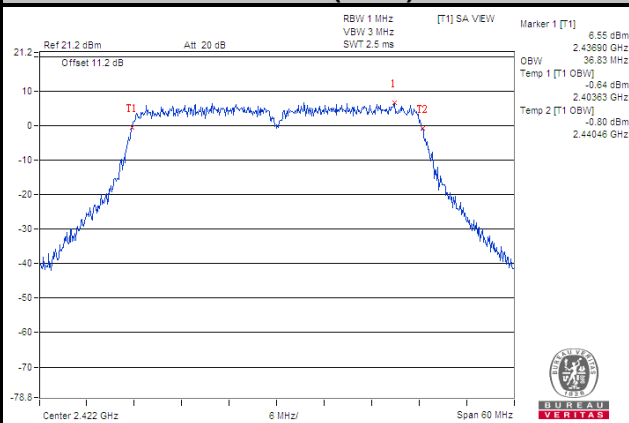

802.11ax (HE20)

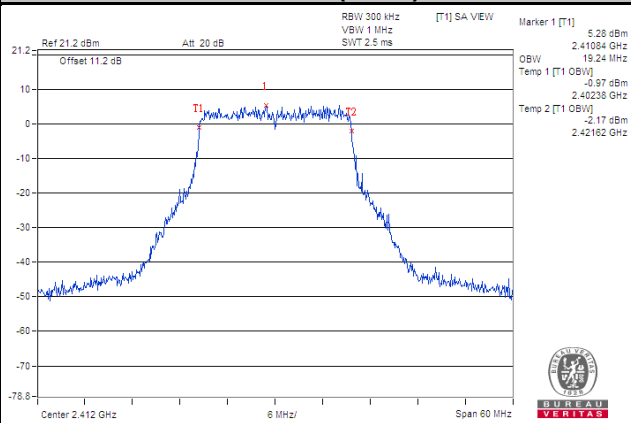

802.11ax (HE40)

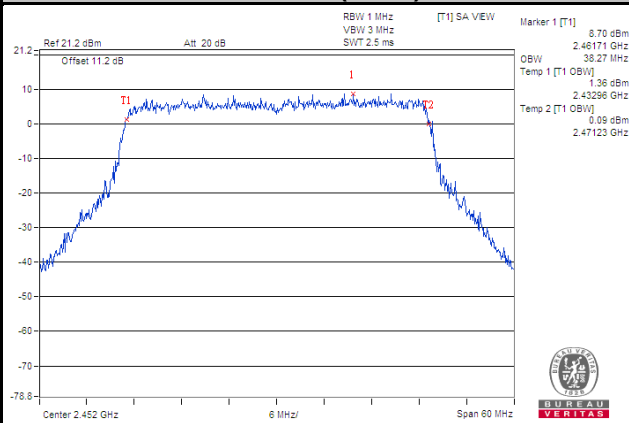

## 4.5 Conducted Output Power Measurement

### 4.5.1 Limits of Conducted Output Power Measurement

For systems using digital modulation in the 2400–2483.5 MHz bands: 1 Watt (30 dBm)

Per KDB 662911 D01 Multiple Transmitter Output Method of conducted output power measurement on IEEE 802.11 devices,

Array Gain = 0 dB (i.e., no array gain) for NANT  $\leq$  4;

Array Gain = 0 dB (i.e., no array gain) for channel widths  $\geq$  40 MHz for any NANT;

Array Gain =  $5 \log(\text{NANT}/\text{NSS})$  dB or 3 dB, whichever is less for 20 MHz channel widths with NANT  $\geq$  5.

For power measurements on all other devices: Array Gain =  $10 \log(\text{NANT}/\text{NSS})$  dB.

### 4.5.2 Test Setup

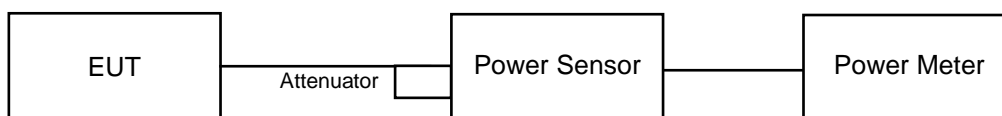

### 4.5.3 Test Instruments

Refer to section 4.1.2 to get information of above instrument.

### 4.5.4 Test Procedures

A peak power sensor was used on the output port of the EUT. A power meter was used to read the response of the peak power sensor. Record the power level.

### 4.5.5 Deviation from Test Standard

No deviation.

### 4.5.6 EUT Operating Conditions

The software provided by client to enable the EUT under transmission condition continuously at lowest, middle and highest channel frequencies individually.

#### 4.5.7 Test Results

##### 802.11b

Channel	Frequency (MHz)	Peak Power (mW)	Peak Power (dBm)	Limit (dBm)	Pass / Fail
1	2412	48.865	16.89	30	Pass
6	2437	48.417	16.85	30	Pass
11	2462	48.641	16.87	30	Pass
12	2467	48.753	16.88	30	Pass
13	2472	48.417	16.85	30	Pass

##### 802.11g

Channel	Frequency (MHz)	Peak Power (mW)	Peak Power (dBm)	Limit (dBm)	Pass / Fail
1	2412	90.991	19.59	30	Pass
6	2437	93.972	19.73	30	Pass
11	2462	92.897	19.68	30	Pass
12	2467	93.972	19.73	30	Pass
13	2472	43.053	16.34	30	Pass

##### 802.11n (HT20)

Channel	Frequency (MHz)	Peak Power (dBm)		Total Power (mW)	Total Power (dBm)	Limit (dBm)	Pass / Fail
		Chain 0	Chain 1				
1	2412	18.27	18.03	130.676	21.16	30	Pass
6	2437	19.69	19.60	184.312	22.66	30	Pass
11	2462	19.57	19.61	181.984	22.60	30	Pass
12	2467	18.12	17.69	123.612	20.92	30	Pass
13	2472	15.17	14.65	62.059	17.93	30	Pass

##### 802.11n (HT40)

Channel	Frequency (MHz)	Peak Power (dBm)		Total Power (mW)	Total Power (dBm)	Limit (dBm)	Pass / Fail
		Chain 0	Chain 1				
3	2422	18.26	18.43	136.651	21.36	30	Pass
6	2437	19.61	19.53	181.154	22.58	30	Pass
9	2452	19.46	19.37	174.805	22.43	30	Pass
10	2457	12.19	12.38	33.856	15.30	30	Pass
11	2462	19.07	19.05	161.077	22.07	30	Pass

**802.11ax (HE20)**

Channel	Frequency (MHz)	Peak Power (dBm)		Total Power (mW)	Total Power (dBm)	Limit (dBm)	Pass / Fail
		Chain 0	Chain 1				
1	2412	18.07	17.66	122.466	20.88	30	Pass
6	2437	19.66	19.41	179.767	22.55	30	Pass
11	2462	19.64	19.51	181.376	22.59	30	Pass
12	2467	17.67	17.52	114.973	20.61	30	Pass
13	2472	19.76	19.07	175.348	22.44	30	Pass

**802.11ax (HE40)**

Channel	Frequency (MHz)	Peak Power (dBm)		Total Power (mW)	Total Power (dBm)	Limit (dBm)	Pass / Fail
		Chain 0	Chain 1				
3	2422	19.66	19.26	176.803	22.47	30	Pass
6	2437	19.76	19.50	183.749	22.64	30	Pass
9	2452	19.56	19.57	180.938	22.58	30	Pass
10	2457	10.84	11.48	26.194	14.18	30	Pass
11	2462	19.45	19.23	171.858	22.35	30	Pass



## 4.6 Power Spectral Density Measurement

### 4.6.1 Limits of Power Spectral Density Measurement

The Maximum of Power Spectral Density Measurement is 8 dBm in any 3 kHz band during any time interval of continuous transmission.

### 4.6.2 Test Setup

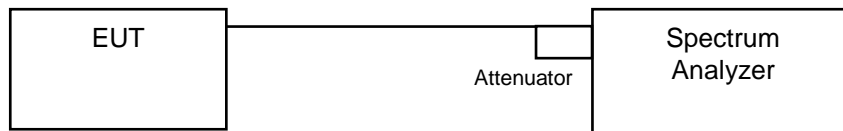

### 4.6.3 Test Instruments

Refer to section 4.1.2 to get information of above instrument.

### 4.6.4 Test Procedure

- a. Set analyzer center frequency to DTS channel center frequency.
- b. Set the span to 1.5 times the DTS bandwidth.
- c. Set the RBW to:  $3 \text{ kHz} \leq \text{RBW} \leq 100 \text{ kHz}$ .
- d. Set the VBW  $\geq 3 \times \text{RBW}$ .
- e. Detector = peak.
- f. Sweep time = auto couple.
- g. Trace mode = max hold.
- h. Allow trace to fully stabilize.
- i. Use the peak marker function to determine the maximum amplitude level within the RBW.

### 4.6.5 Deviation from Test Standard

No deviation.

### 4.6.6 EUT Operating Condition

The software provided by client to enable the EUT under transmission condition continuously at lowest, middle and highest channel frequencies individually.

## 4.6.7 Test Results

## 802.11b

Channel	Frequency (MHz)	PSD (dBm/3 kHz)	Limit (dBm/3 kHz)	Pass / Fail
1	2412	-10.96	8	Pass
6	2437	-10.87	8	Pass
11	2462	-10.70	8	Pass
12	2467	-10.61	8	Pass
13	2472	-11.18	8	Pass

## 802.11g

Channel	Frequency (MHz)	PSD (dBm/3 kHz)	Limit (dBm/3 kHz)	Pass / Fail
1	2412	-11.15	8	Pass
6	2437	-10.99	8	Pass
11	2462	-11.20	8	Pass
12	2467	-11.09	8	Pass
13	2472	-14.87	8	Pass

## 802.11n (HT20)

TX Chain	Channel	Freq. (MHz)	PSD (dBm/3 kHz)	10 log (N=2) dB	Total PSD (dBm/3 kHz)	Limit (dBm/3 kHz)	Pass / Fail
0	1	2412	-13.78	3.01	-10.77	8	Pass
	6	2437	-11.88	3.01	-8.87	8	Pass
	11	2462	-12.84	3.01	-9.83	8	Pass
	12	2467	-13.85	3.01	-10.84	8	Pass
	13	2472	-18.31	3.01	-15.30	8	Pass
1	1	2412	-14.03	3.01	-11.02	8	Pass
	6	2437	-12.07	3.01	-9.06	8	Pass
	11	2462	-12.85	3.01	-9.84	8	Pass
	12	2467	-14.09	3.01	-11.08	8	Pass
	13	2472	-18.13	3.01	-15.12	8	Pass

## NOTE:

1. Directional gain =  $-0.15 \text{ dBi} + 10\log(2) = 2.86 \text{ dBi} < 6 \text{ dBi}$ , so the limit no need to be reduced.
2. Method E) 2) c) of power density measurement of KDB 662911 is using for calculating total power density, Measure and add 10 log (NANT) dB.

### 802.11n (HT40)

TX Chain	Channel	Freq. (MHz)	PSD (dBm/3 kHz)	10 log (N=2) dB	Total PSD (dBm/3 kHz)	Limit (dBm/3 kHz)	Pass / Fail
0	3	2422	-17.51	3.01	-14.50	8	Pass
	6	2437	-15.09	3.01	-12.08	8	Pass
	9	2452	-16.40	3.01	-13.39	8	Pass
	10	2457	-21.42	3.01	-18.41	8	Pass
	11	2462	-20.95	3.01	-17.94	8	Pass
1	3	2422	-17.83	3.01	-14.82	8	Pass
	6	2437	-15.57	3.01	-12.56	8	Pass
	9	2452	-16.72	3.01	-13.71	8	Pass
	10	2457	-22.66	3.01	-19.65	8	Pass
	11	2462	-21.72	3.01	-18.71	8	Pass

**NOTE:**

1. Directional gain =  $-0.15 \text{ dBi} + 10\log(2) = 2.86 \text{ dBi} < 6 \text{ dBi}$ , so the limit no need to be reduced.
2. Method E) 2) c) of power density measurement of KDB 662911 is using for calculating total power density, Measure and add  $10 \log (NANT) \text{ dB}$ .

### 802.11ax (HE20)

TX Chain	Channel	Freq. (MHz)	PSD (dBm/3 kHz)	10 log (N=2) dB	Total PSD (dBm/3 kHz)	Limit (dBm/3 kHz)	Pass / Fail
0	1	2412	-14.19	3.01	-11.18	8	Pass
	6	2437	-13.21	3.01	-10.20	8	Pass
	11	2462	-13.04	3.01	-10.03	8	Pass
	12	2467	-15.69	3.01	-12.68	8	Pass
	13	2472	-19.30	3.01	-16.29	8	Pass
1	1	2412	-14.57	3.01	-11.56	8	Pass
	6	2437	-13.35	3.01	-10.34	8	Pass
	11	2462	-13.20	3.01	-10.19	8	Pass
	12	2467	-16.11	3.01	-13.10	8	Pass
	13	2472	-19.89	3.01	-16.88	8	Pass

**NOTE:**

1. Directional gain =  $-0.15 \text{ dBi} + 10\log(2) = 2.86 \text{ dBi} < 6 \text{ dBi}$ , so the limit no need to be reduced.
2. Method E) 2) c) of power density measurement of KDB 662911 is using for calculating total power density, Measure and add  $10 \log (NANT) \text{ dB}$ .

### 802.11ax (HE40)

TX Chain	Channel	Freq. (MHz)	PSD (dBm/3 kHz)	10 log (N=2) dB	Total PSD (dBm/3 kHz)	Limit (dBm/3 kHz)	Pass / Fail
0	3	2422	-17.74	3.01	-14.73	8	Pass
	6	2437	-15.69	3.01	-12.68	8	Pass
	9	2452	-16.71	3.01	-13.70	8	Pass
	10	2457	-24.86	3.01	-21.85	8	Pass
	11	2462	-20.53	3.01	-17.52	8	Pass
1	3	2422	-17.84	3.01	-14.83	8	Pass
	6	2437	-15.97	3.01	-12.96	8	Pass
	9	2452	-16.98	3.01	-13.97	8	Pass
	10	2457	-24.40	3.01	-21.39	8	Pass
	11	2462	-20.63	3.01	-17.62	8	Pass

**NOTE:**

1. Directional gain =  $-0.15 \text{ dBi} + 10\log(2) = 2.86 \text{ dBi} < 6 \text{ dBi}$ , so the limit no need to be reduced.
2. Method E) 2) c) of power density measurement of KDB 662911 is using for calculating total power density, Measure and add  $10 \log (NANT) \text{ dB}$ .

### Spectrum Plot of Worst Value

#### 802.11b

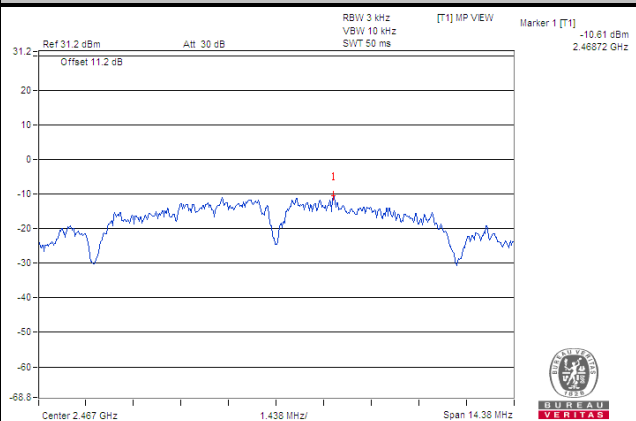

#### 802.11g

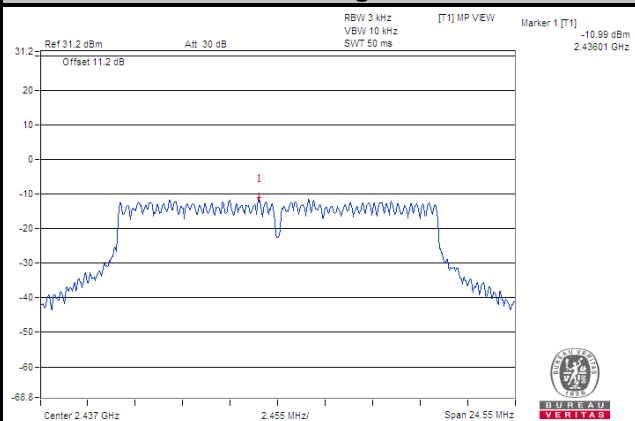

#### 802.11n (HT20)

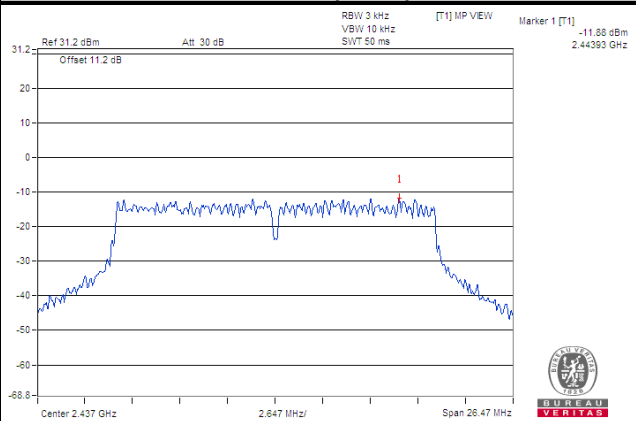

#### 802.11n (HT40)

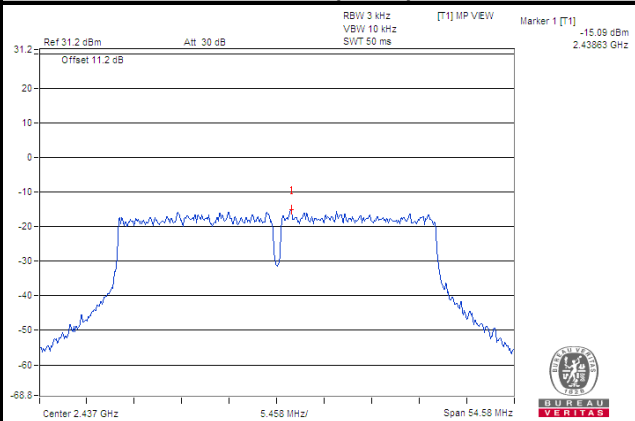

#### 802.11ax (HE20)

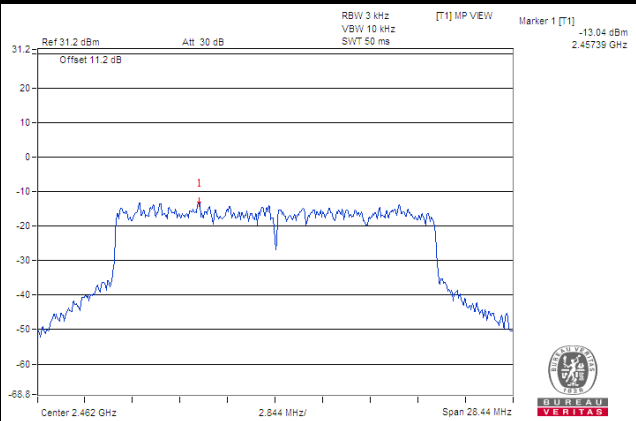

#### 802.11ax (HE40)

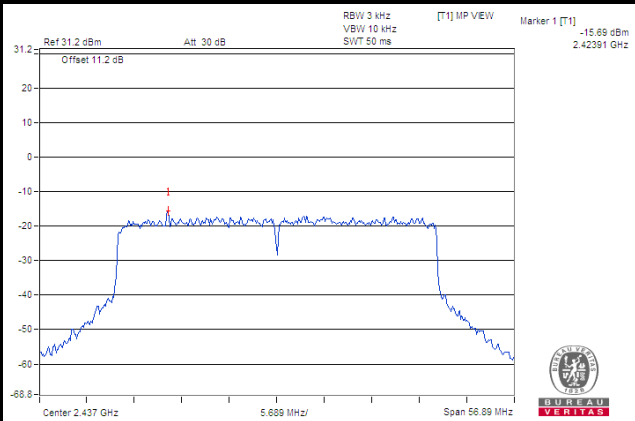

## 4.7 Conducted Out of Band Emission Measurement

### 4.7.1 Limits of Conducted Out of Band Emission Measurement

Below -20 dB of the highest emission level of operating band (in 100 kHz Resolution Bandwidth).

### 4.7.2 Test Setup

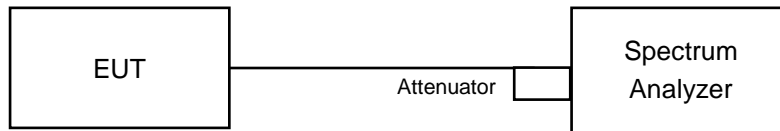

### 4.7.3 Test Instruments

Refer to section 4.1.2 to get information of above instrument.

### 4.7.4 Test Procedure

#### MEASUREMENT PROCEDURE REF

1. Set the RBW = 100 kHz.
2. Set the VBW  $\geq$  300 kHz.
3. Detector = peak.
4. Sweep time = auto couple.
5. Trace mode = max hold.
6. Allow trace to fully stabilize.
7. Use the peak marker function to determine the maximum power level in any 100 kHz band segment within the fundamental EBW.

#### MEASUREMENT PROCEDURE OOB

1. Set RBW = 100 kHz.
2. Set VBW  $\geq$  300 kHz.
3. Detector = peak.
4. Sweep = auto couple.
5. Trace Mode = max hold.
6. Allow trace to fully stabilize.
7. Use the peak marker function to determine the maximum amplitude level.

### 4.7.5 Deviation from Test Standard

No deviation.

### 4.7.6 EUT Operating Condition

The software provided by client to enable the EUT under transmission condition continuously at lowest, middle and highest channel frequencies individually.

### 4.7.7 Test Results

The spectrum plots are attached on the following images. D1 line indicates the highest level, and D2 line indicates the 20 dB offset below D1. It shows compliance with the requirement.

802.11b

Ch 1

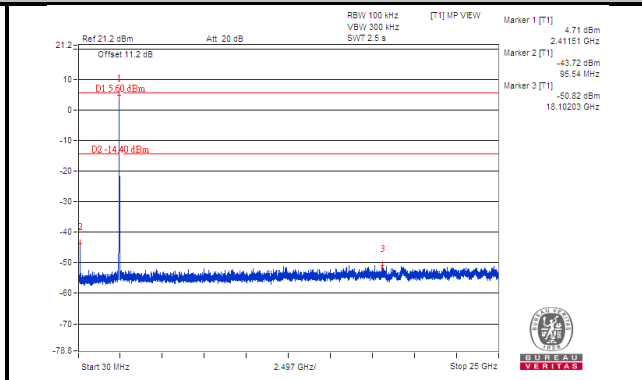
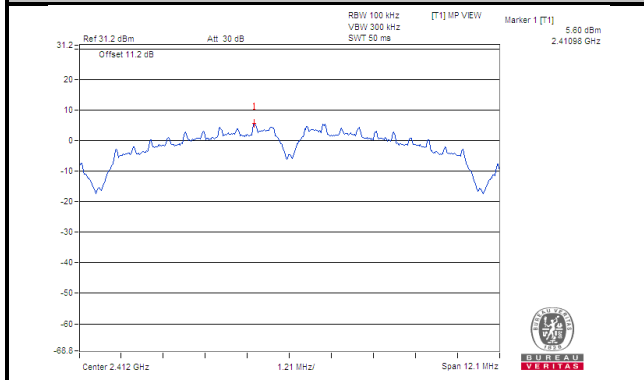

Ch 6

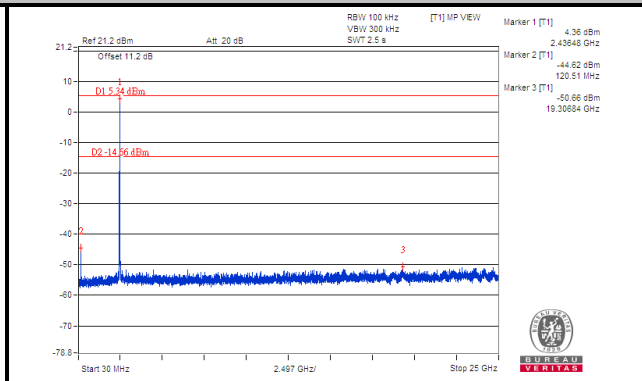
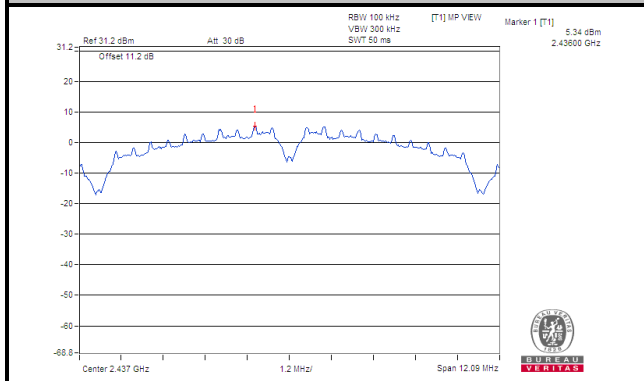

Ch 11

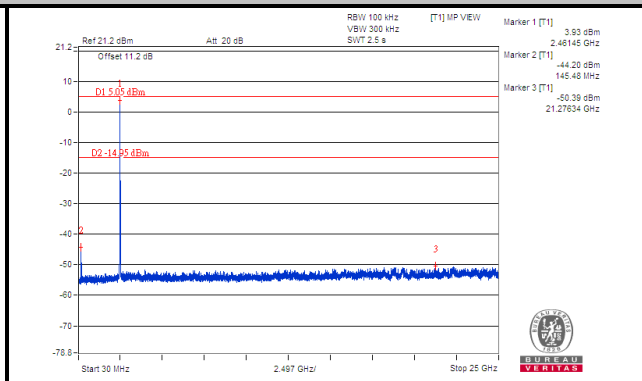
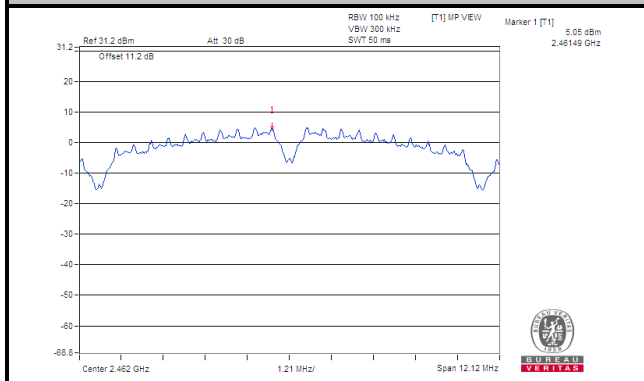

Ch 12

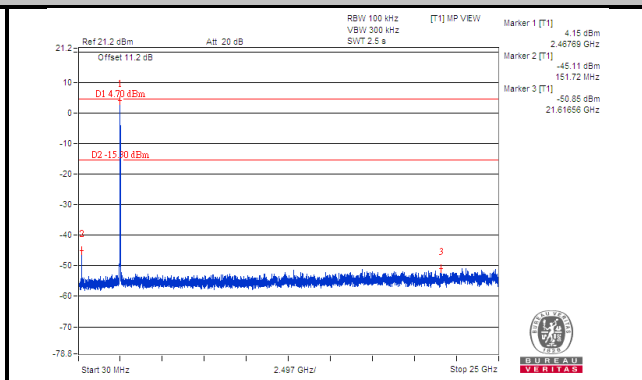
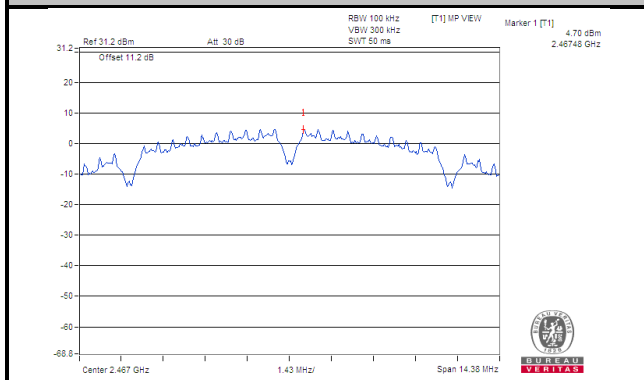

### Ch 13

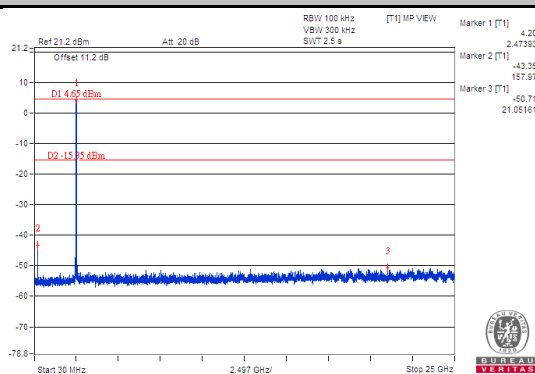
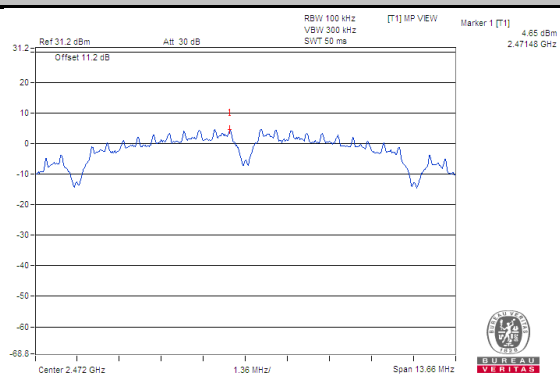

### Ch 1 Band Edge

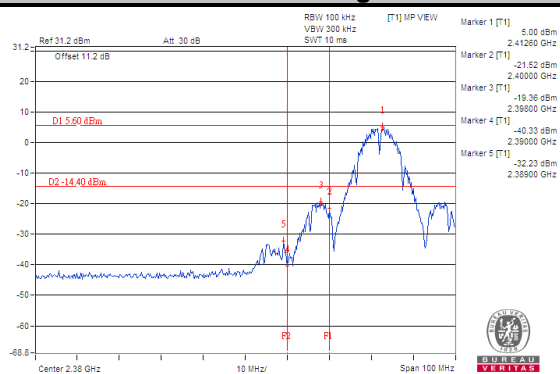

### Ch 11 Band Edge

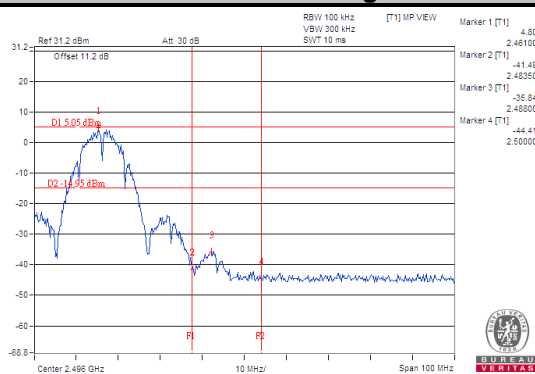

### Ch 12 Band Edge

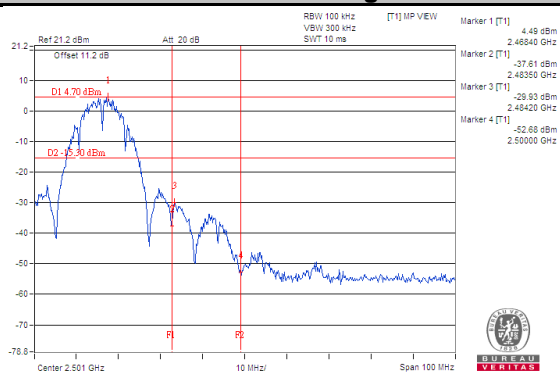

### Ch 13 Band Edge

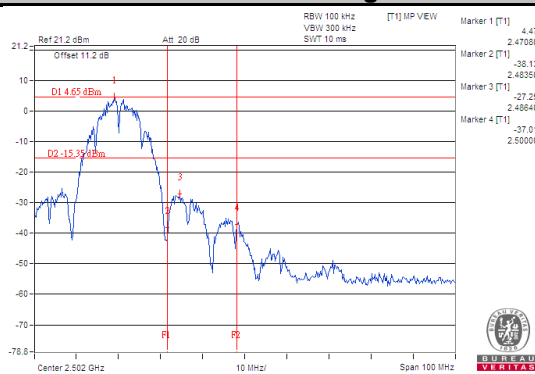



# 802.11g

## Ch 1

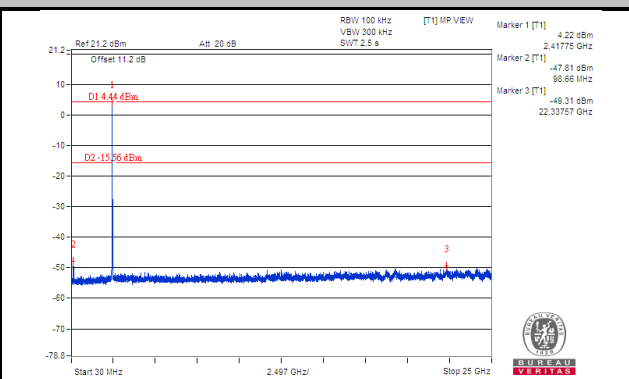
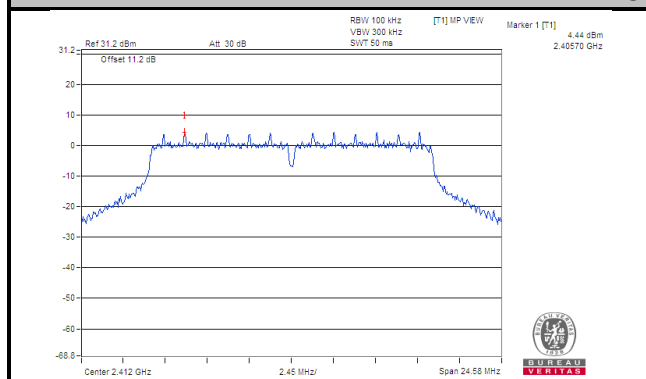

## Ch 6

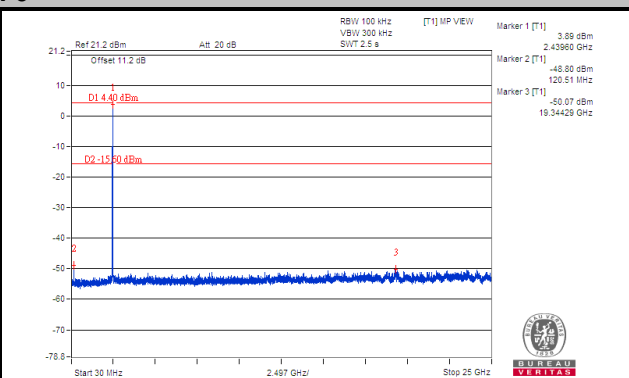
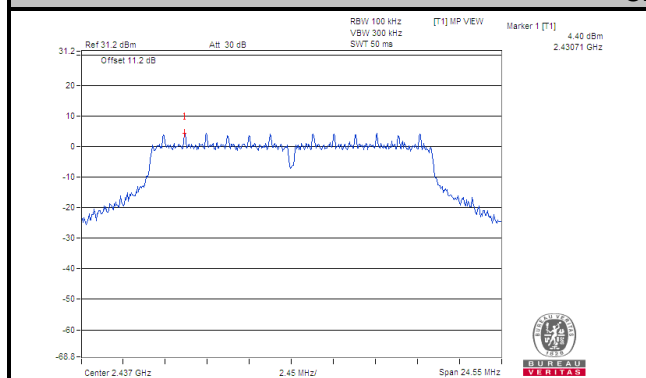

## Ch 11

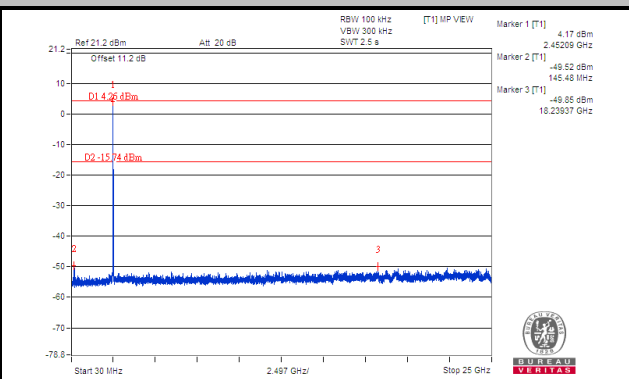
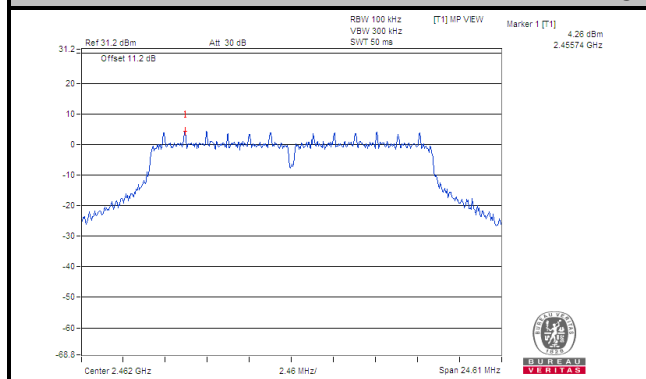

## Ch 12

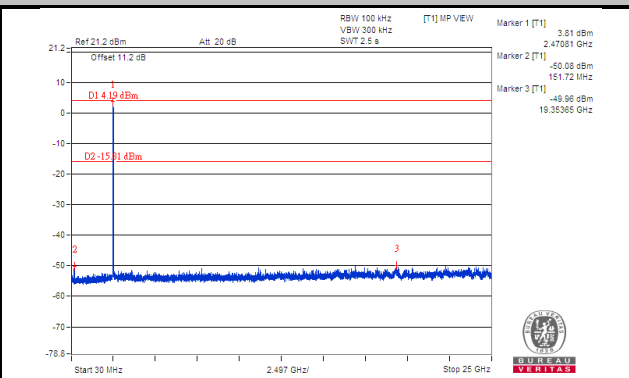
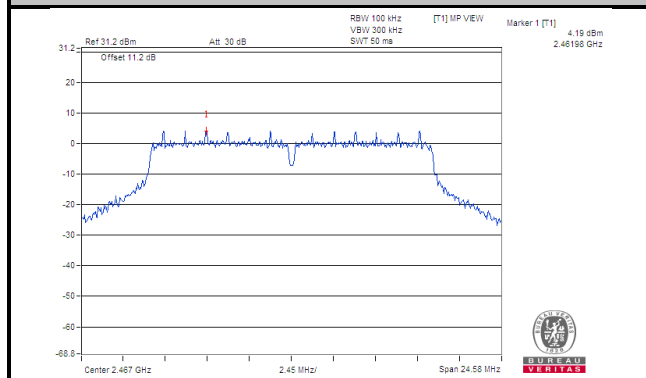

### Ch 13

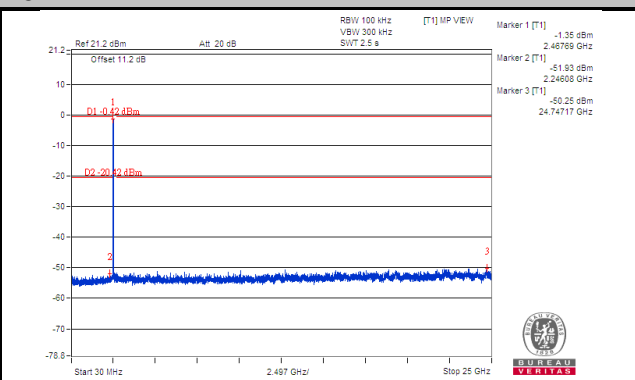
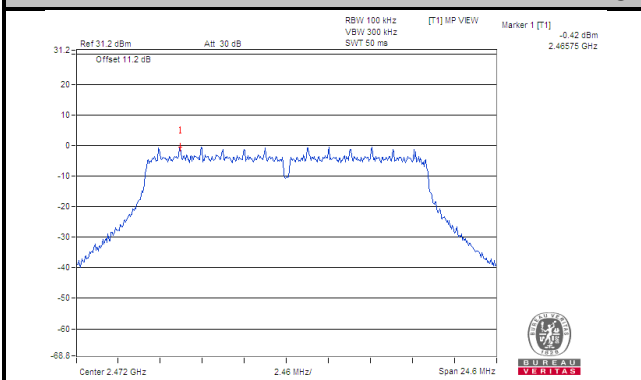

### Ch 1 Band Edge

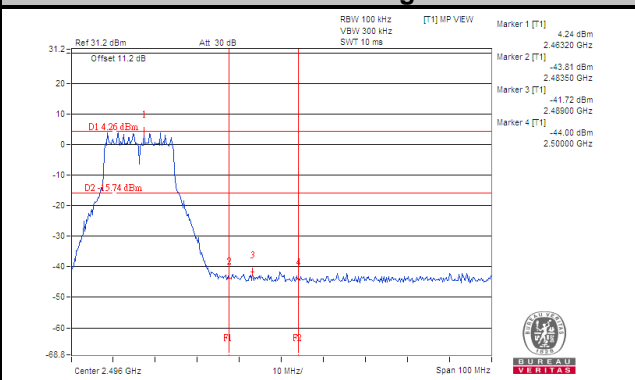
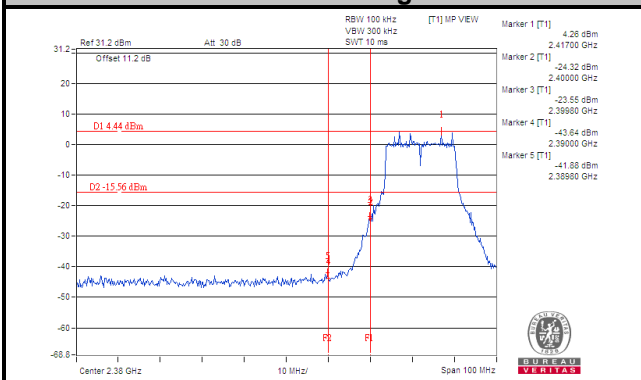

### Ch 12 Band Edge

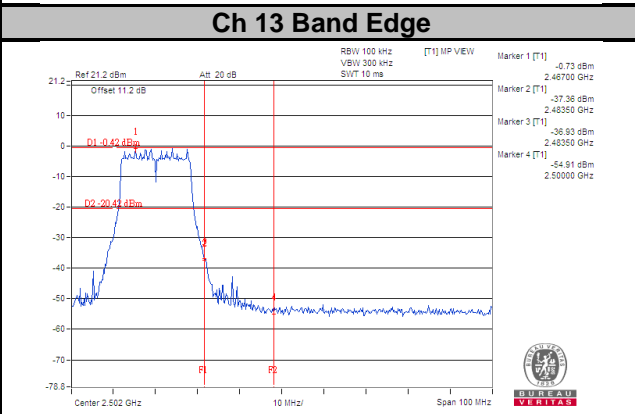
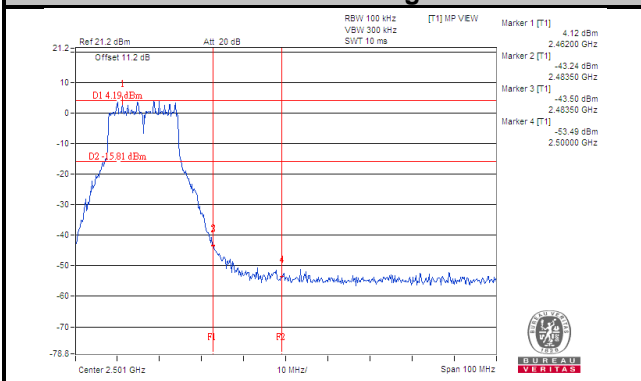

**802.11n (HT20)**  
**CHAIN 0**

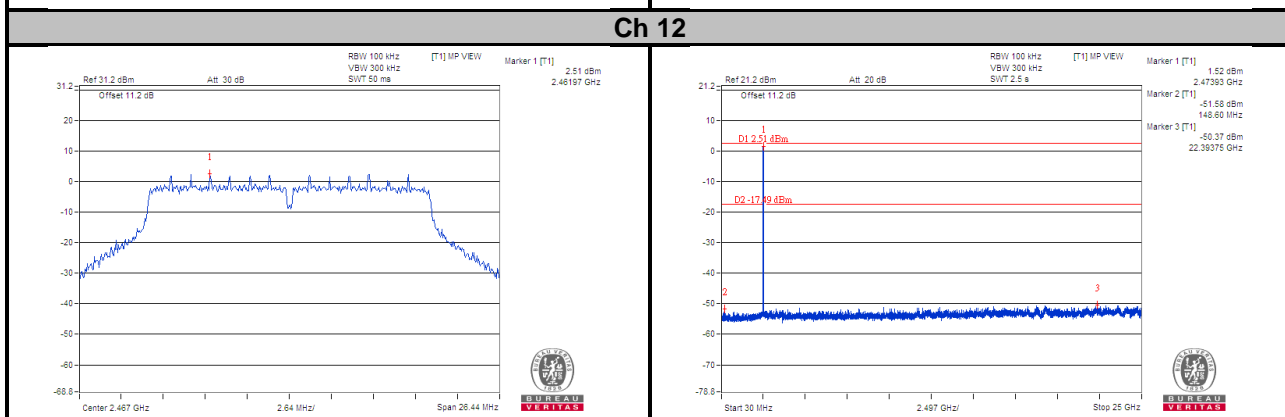
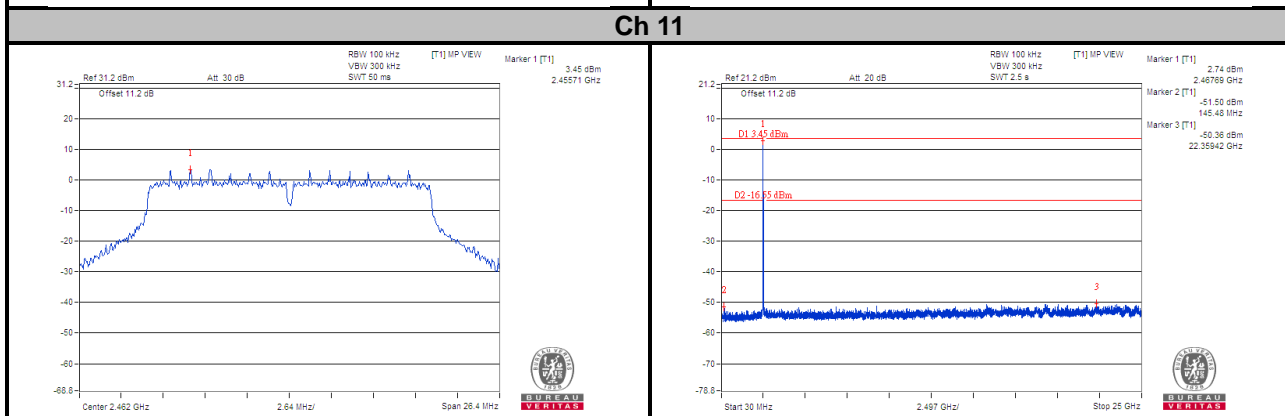
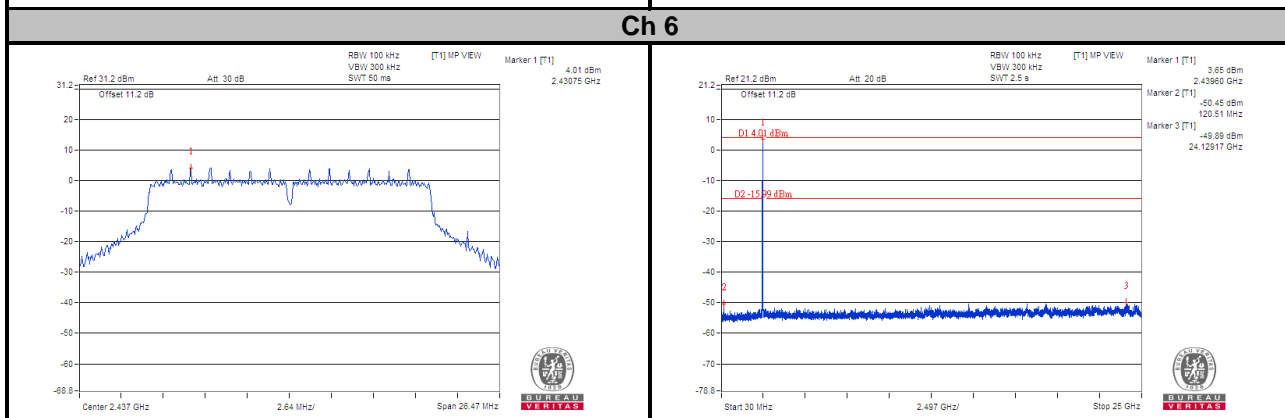
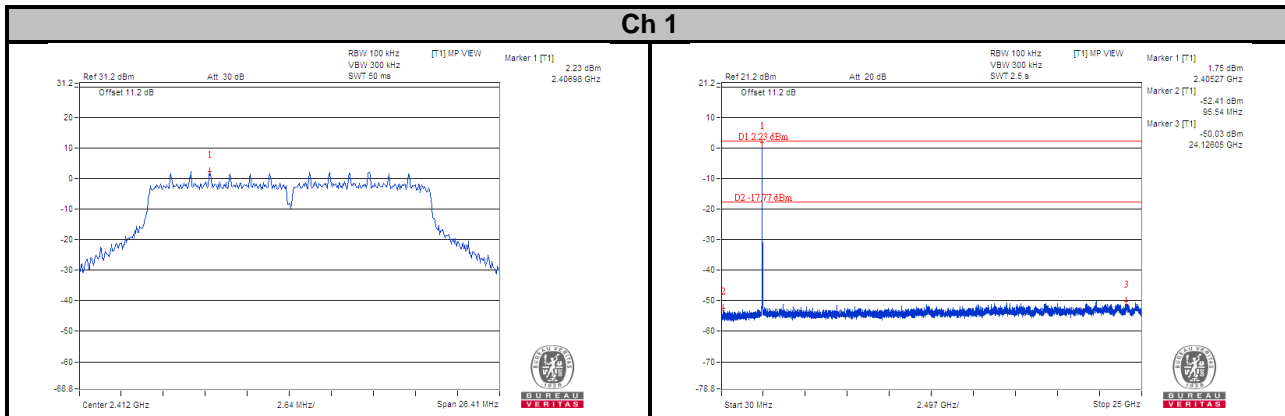

### Ch 13

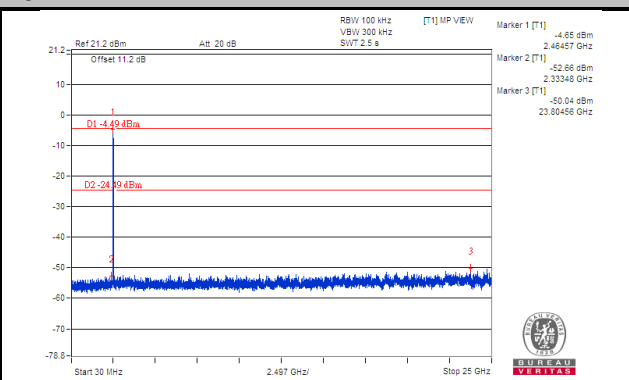
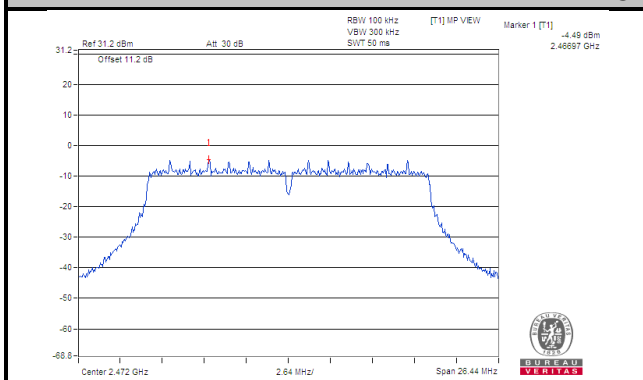

### Ch 1 Band Edge

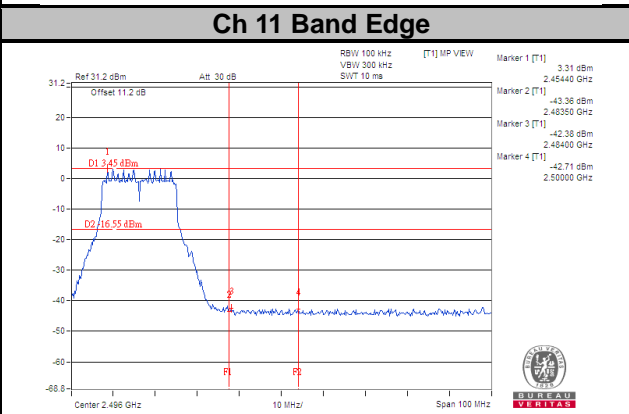
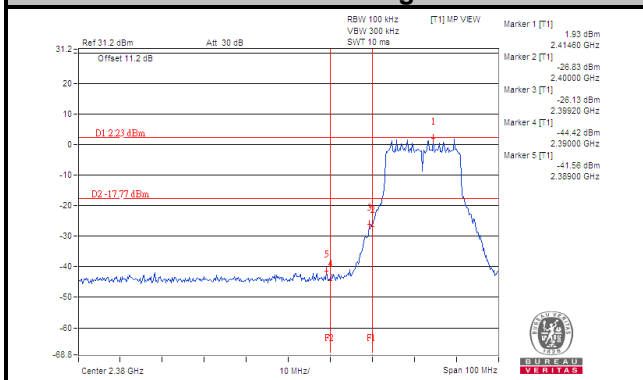

### Ch 12 Band Edge

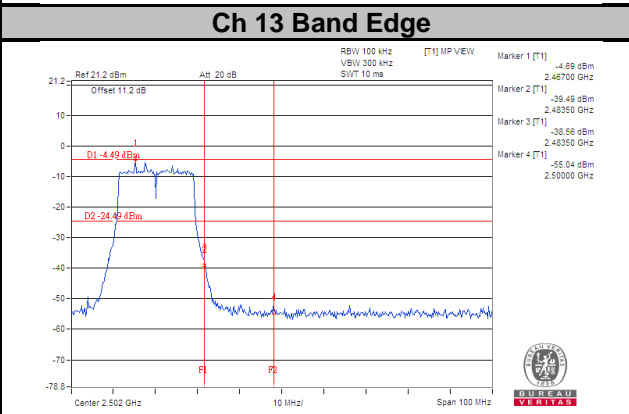
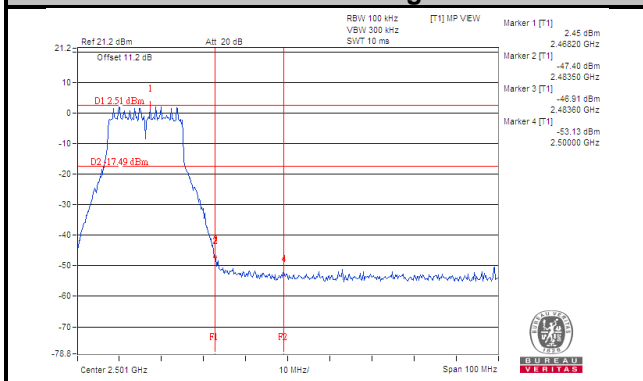

# CHAIN 1

## Ch 1

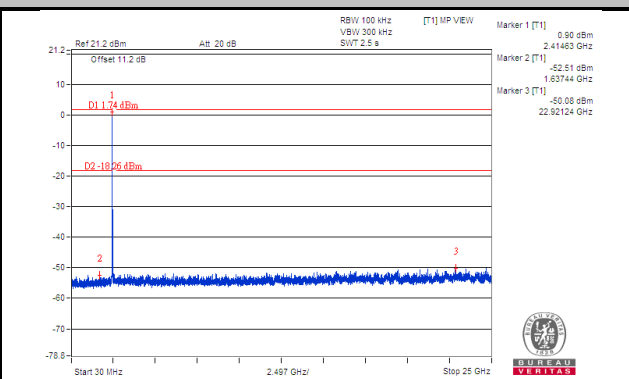
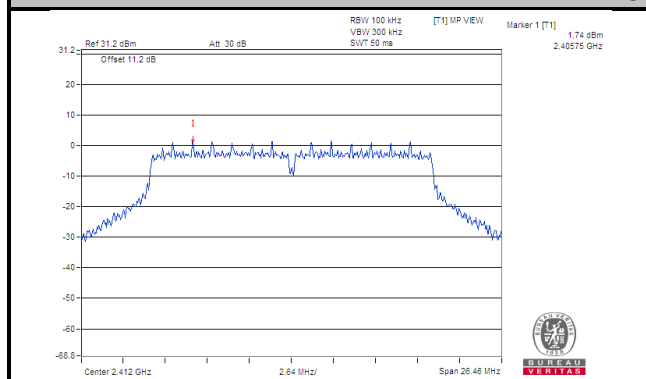

## Ch 6

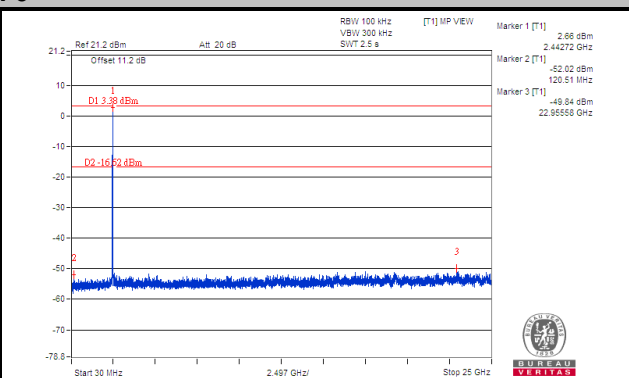
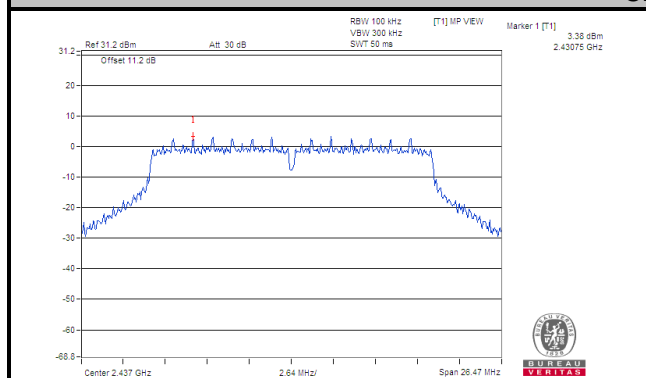

## Ch 11

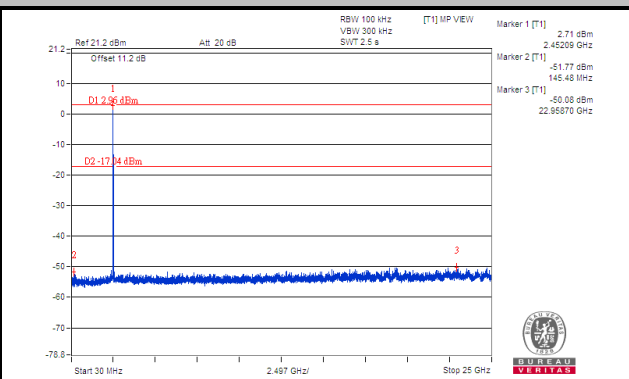
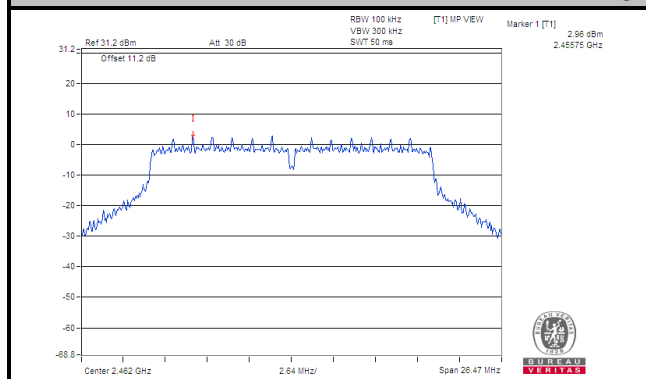

## Ch 12

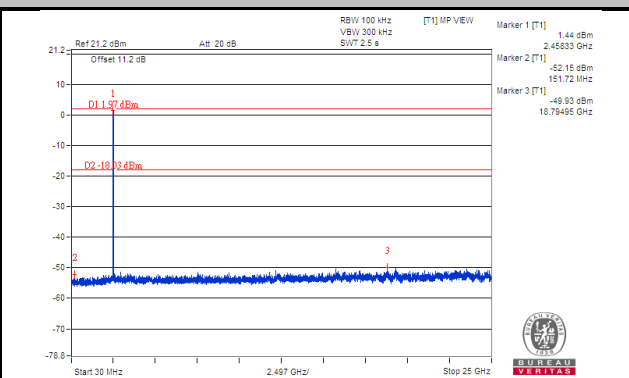
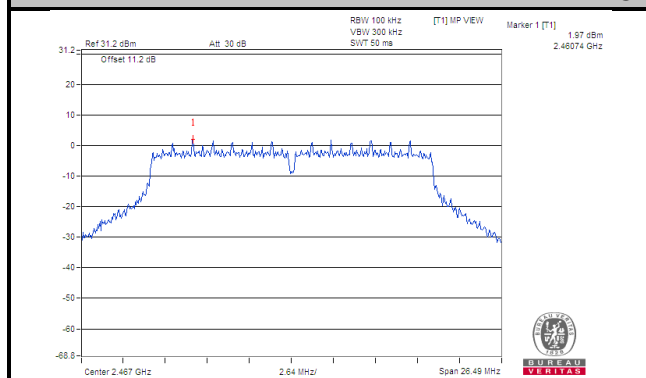

### Ch 13

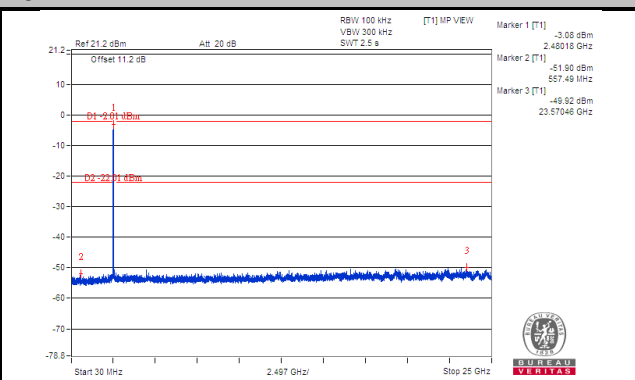
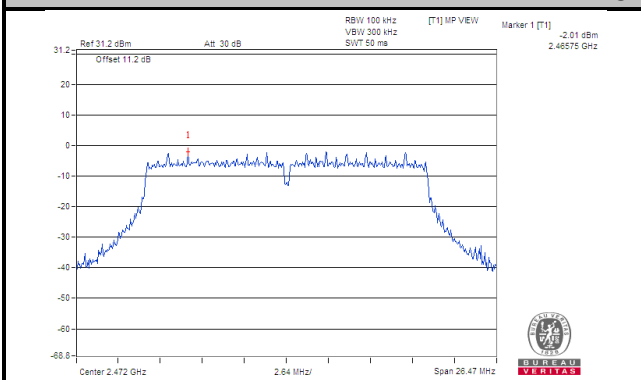

### Ch 1 Band Edge

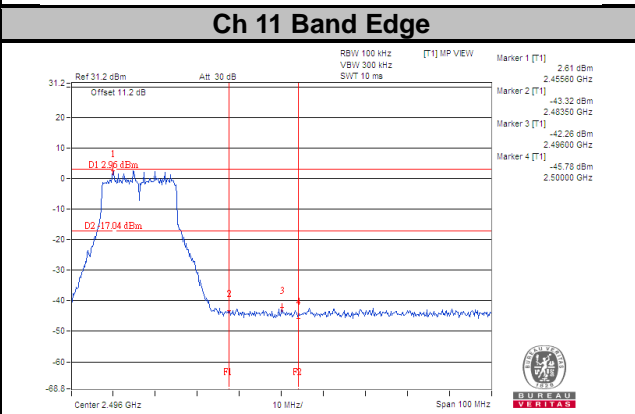
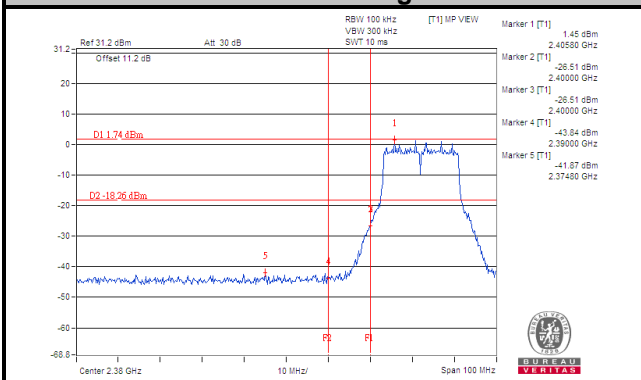

### Ch 12 Band Edge

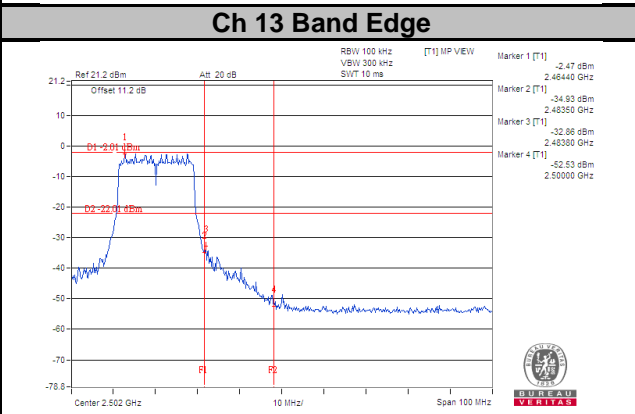
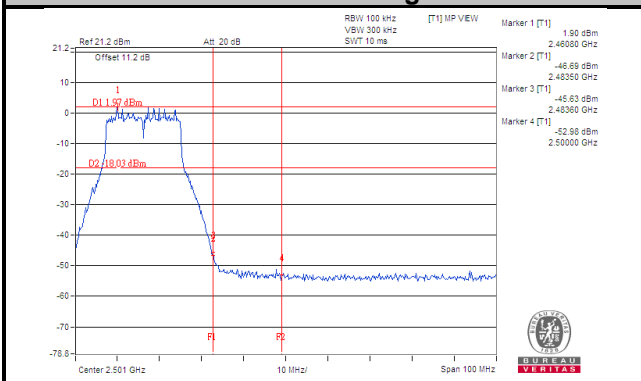

**802.11n (HT40)**  
**CHAIN 0**

**Ch 3**

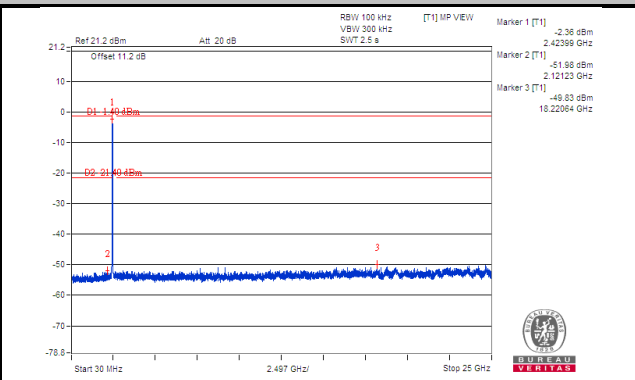
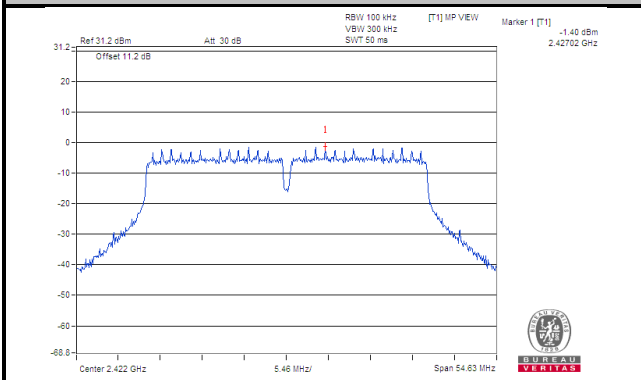

**Ch 6**

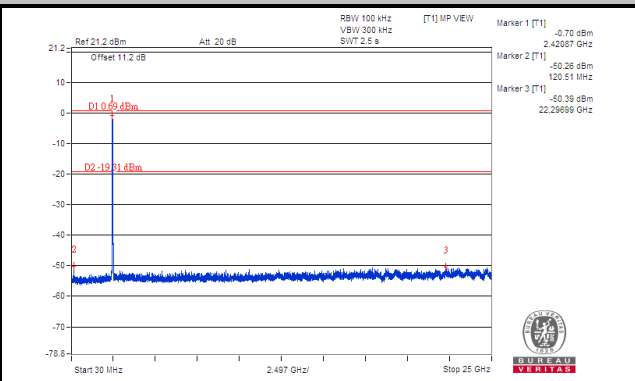
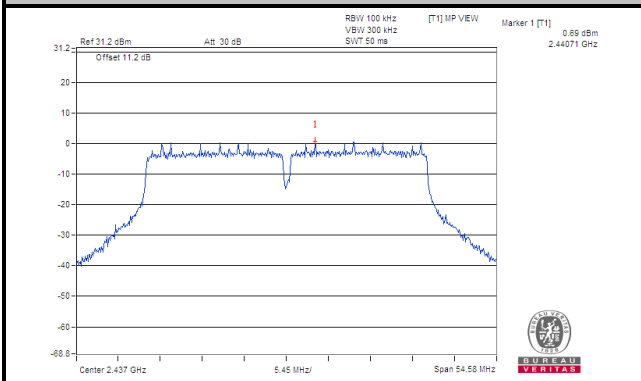

**Ch 9**

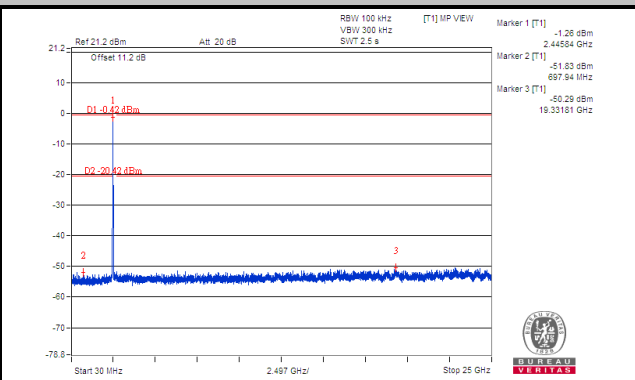
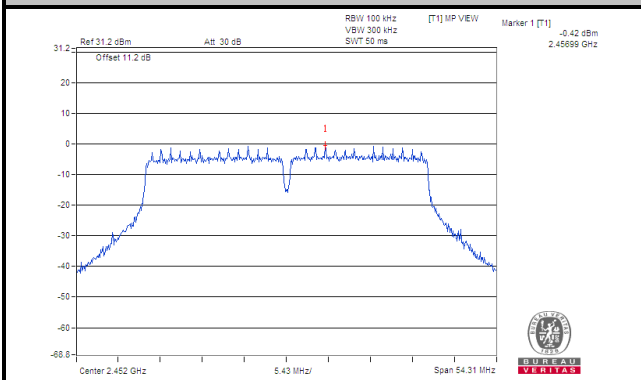

**Ch 10**

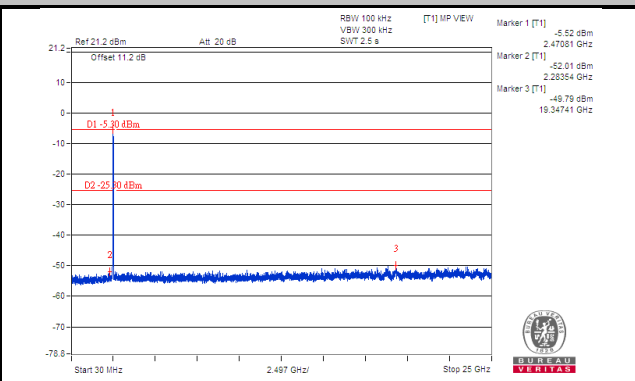
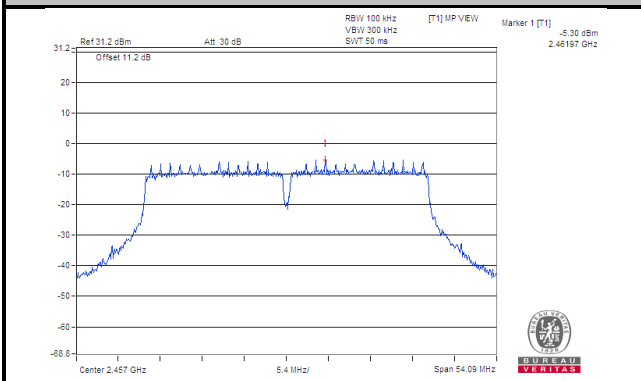

### Ch 11

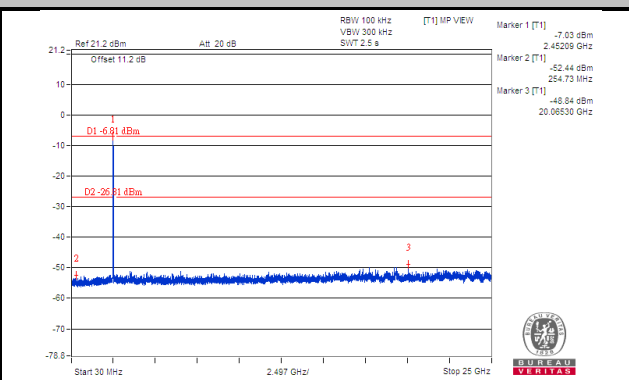
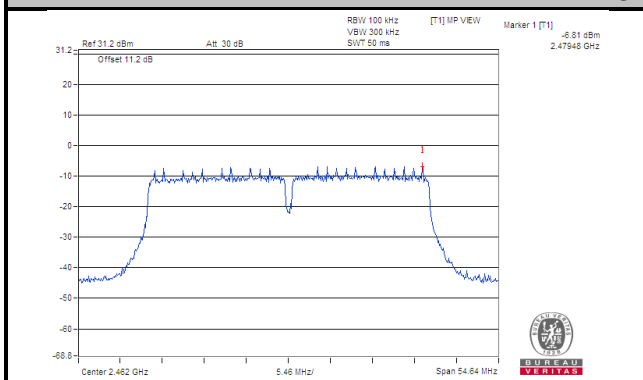

### Ch 3 Band Edge

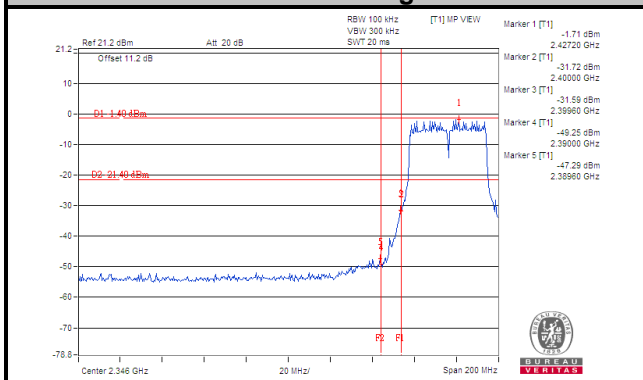

### Ch 9 Band Edge

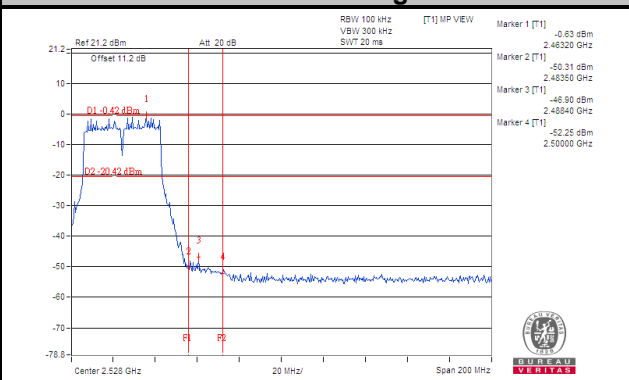

### Ch 10 Band Edge

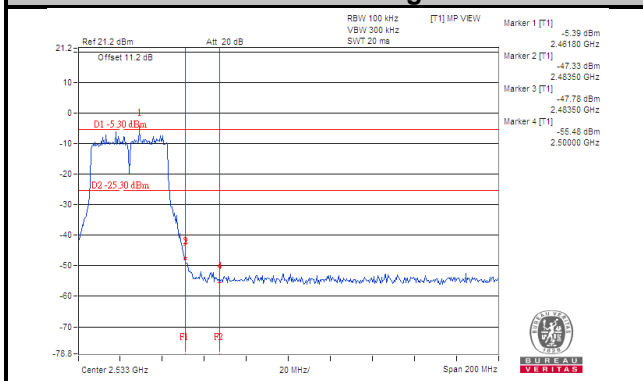

### Ch 11 Band Edge

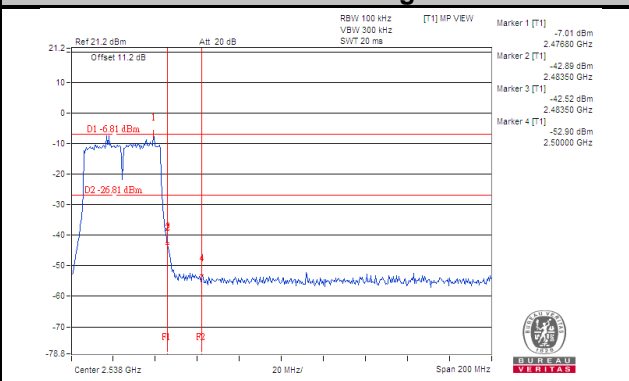



# CHAIN 1

## Ch 3

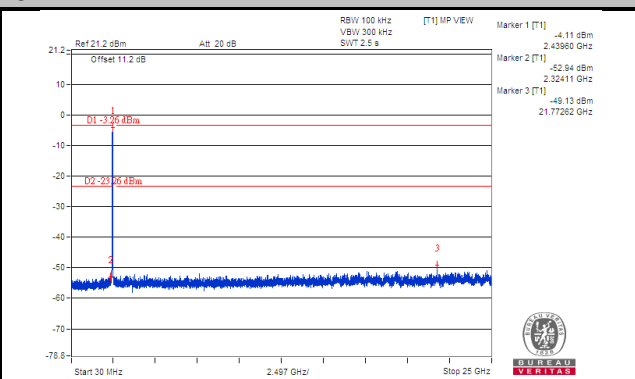
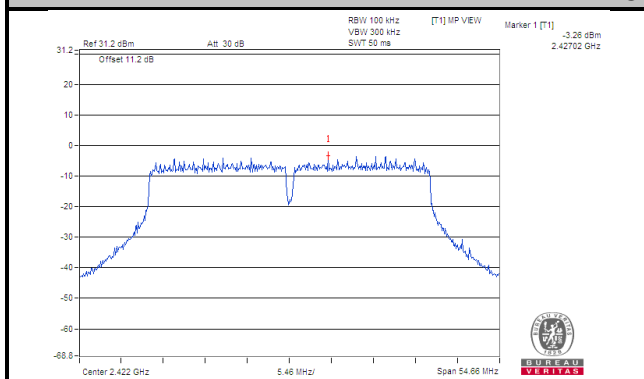

## Ch 6

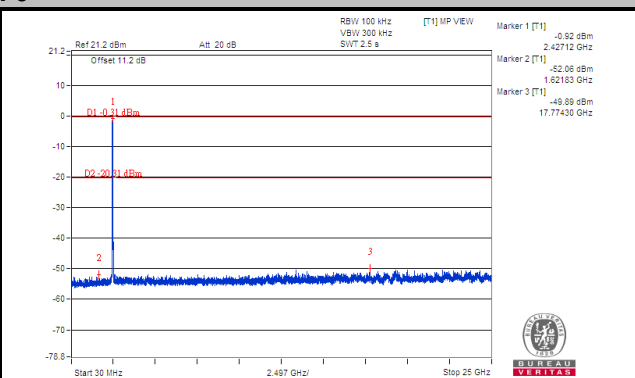
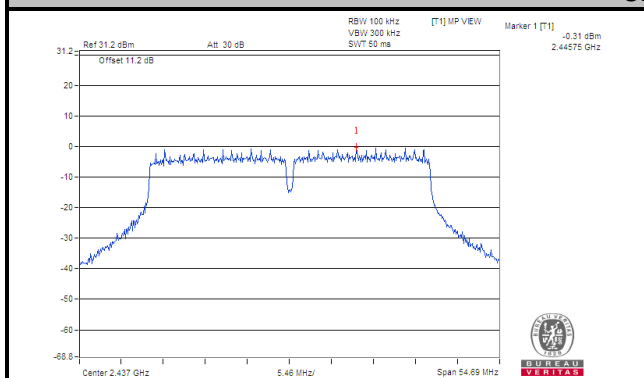

## Ch 9

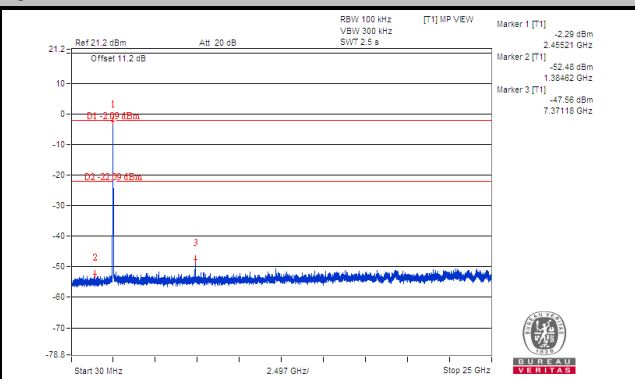
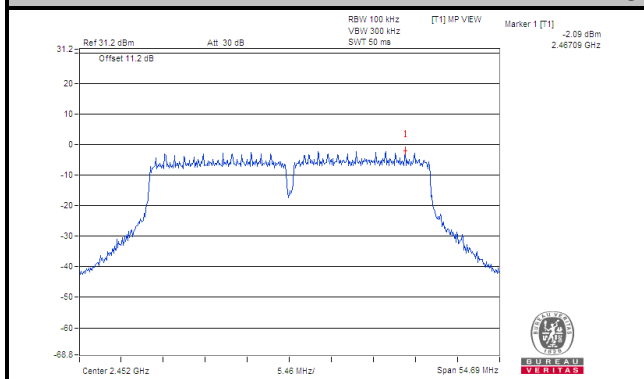

## Ch 10

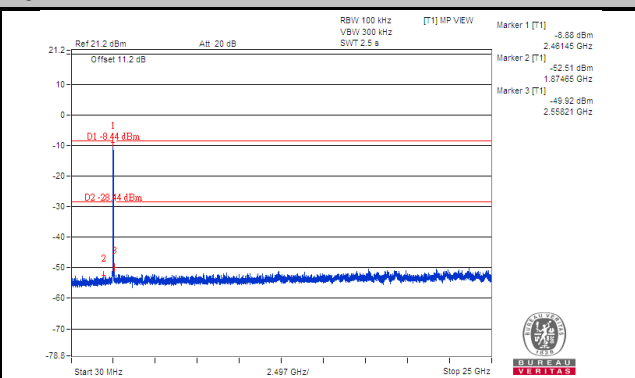
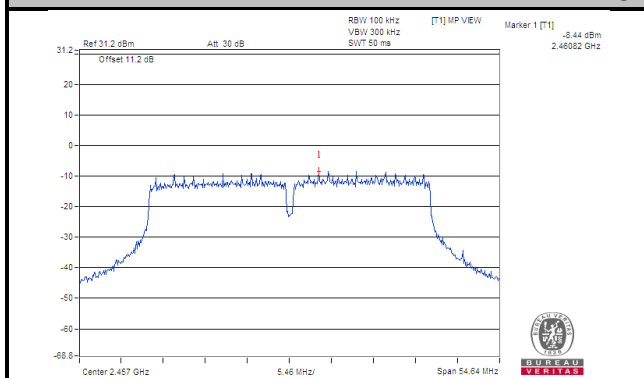

### Ch 11

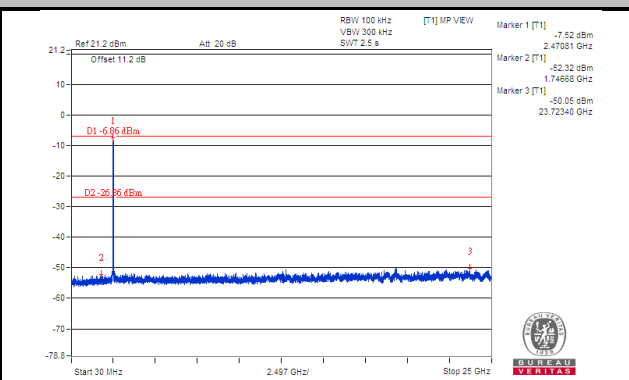
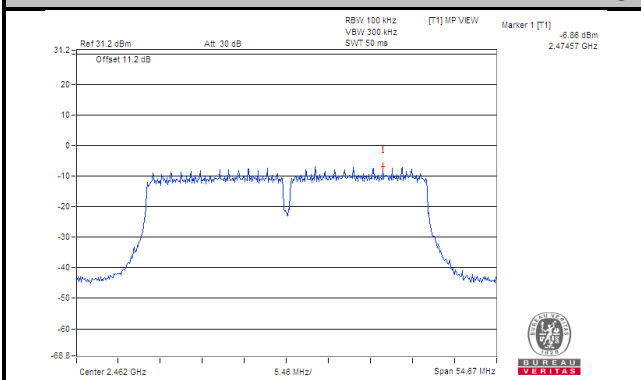

### Ch 3 Band Edge

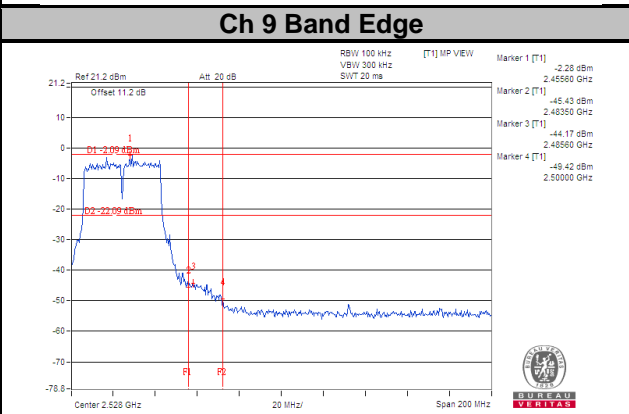
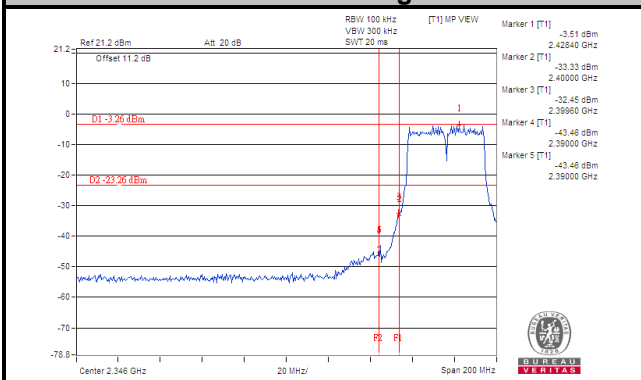

### Ch 10 Band Edge

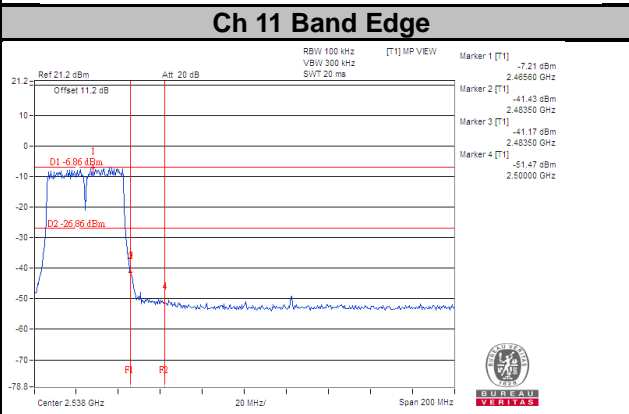
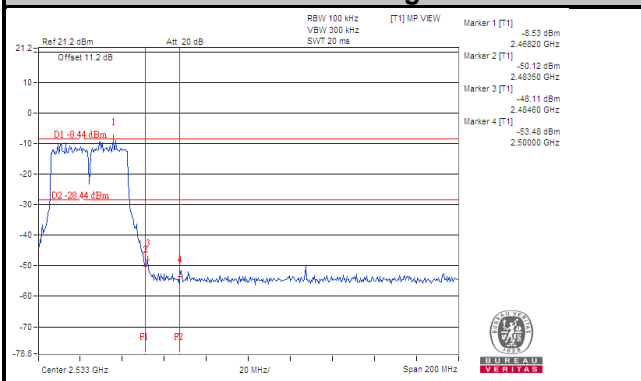

**802.11ax (HE20)**  
**CHAIN 0**

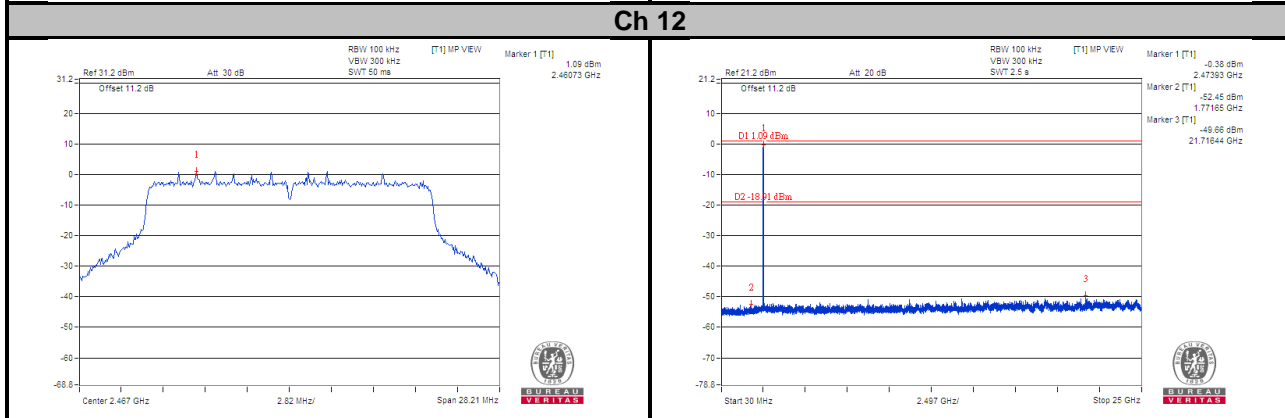
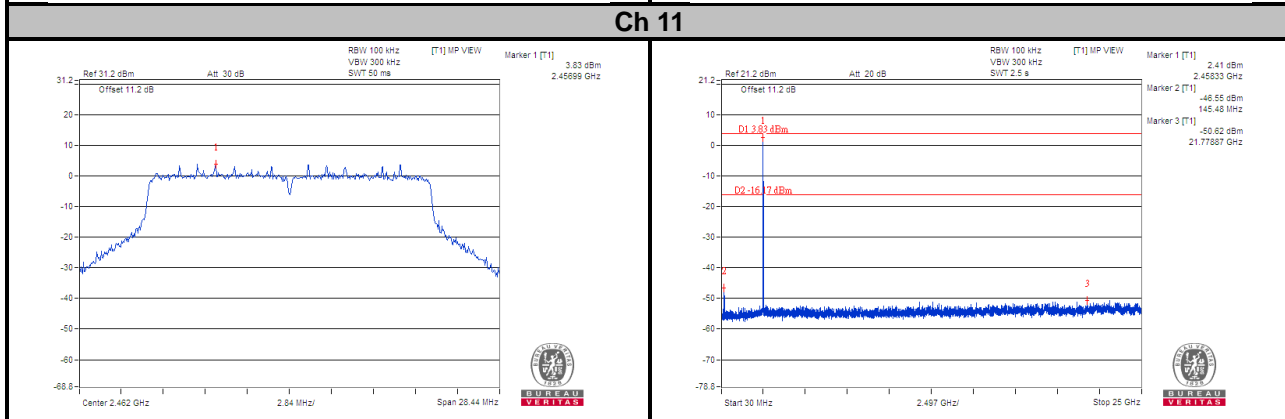
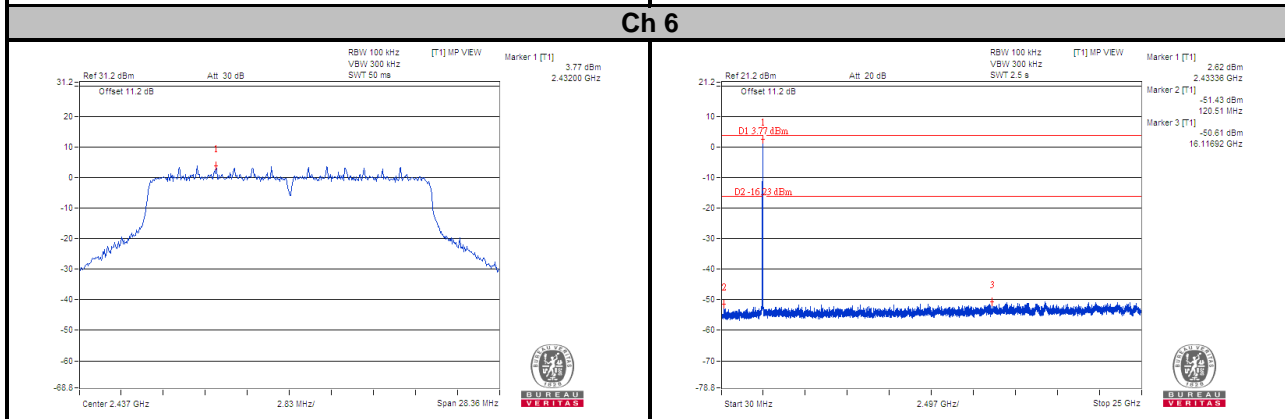
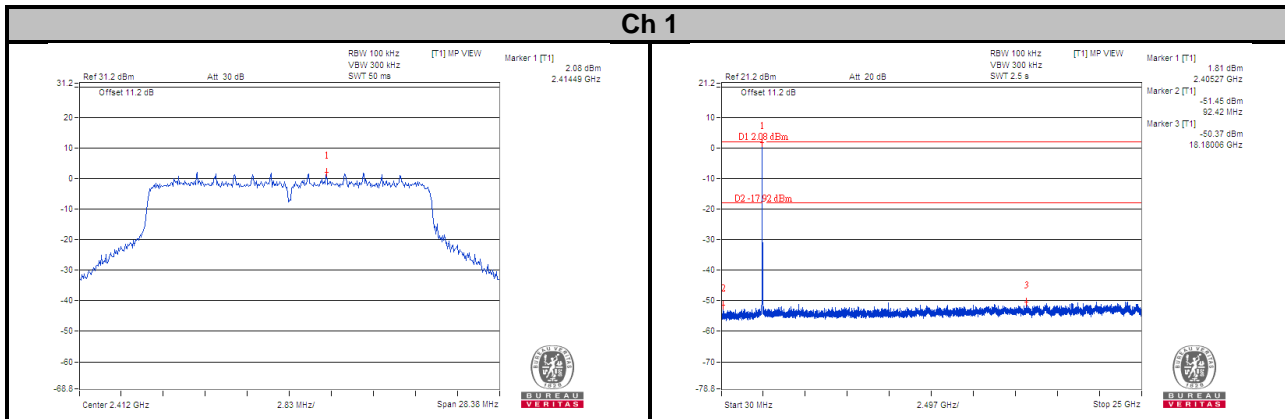

### Ch 13

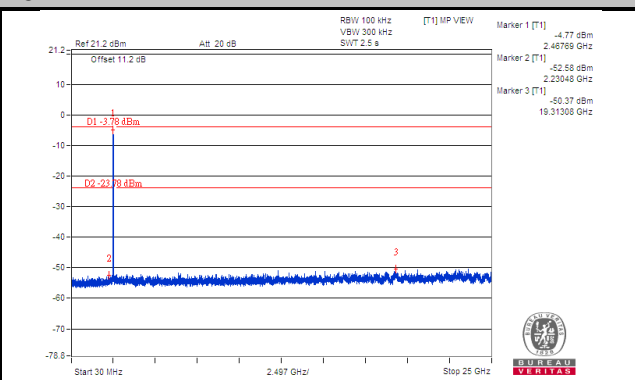
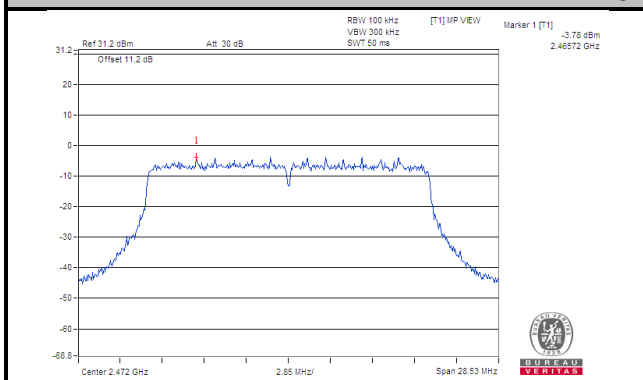

### Ch 1 Band Edge

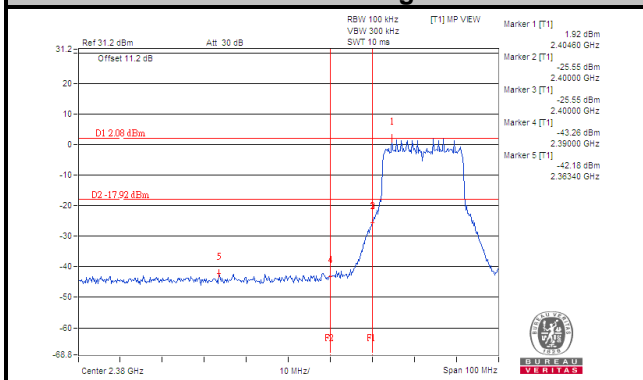

### Ch 11 Band Edge

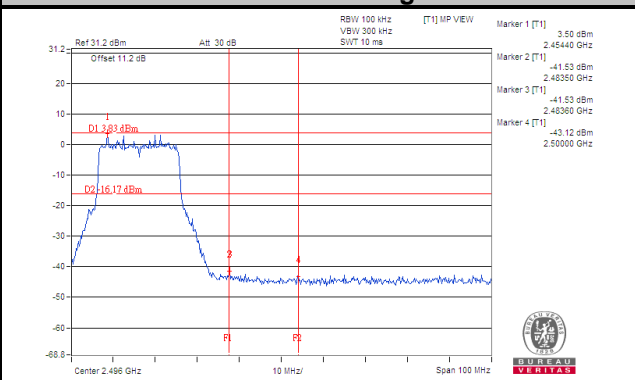

### Ch 12 Band Edge

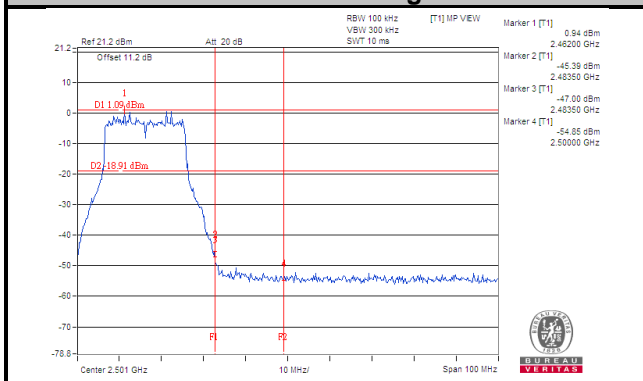

### Ch 13 Band Edge

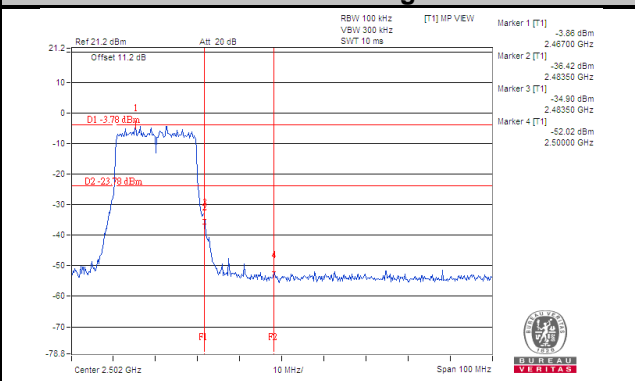

# CHAIN 1

## Ch 1

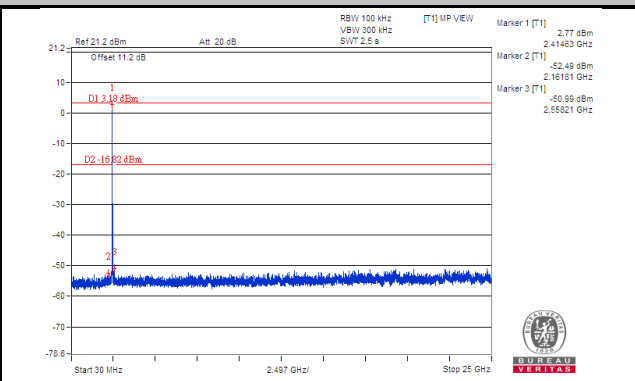
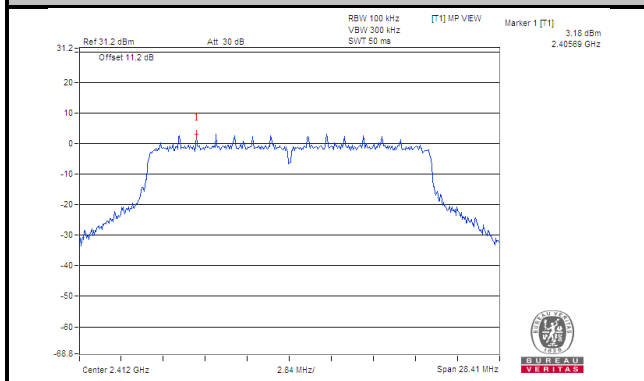

## Ch 6

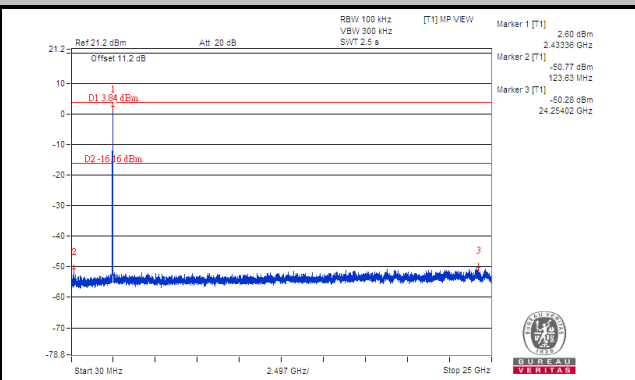
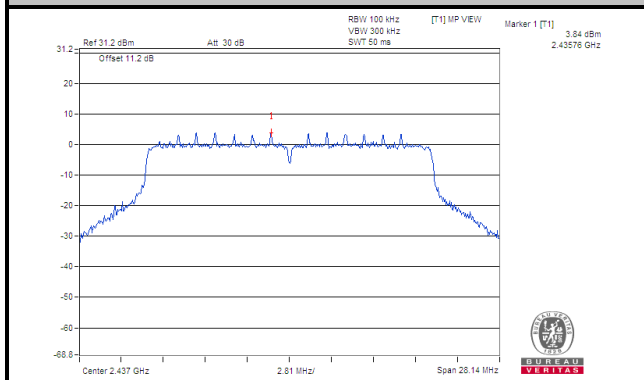

## Ch 11

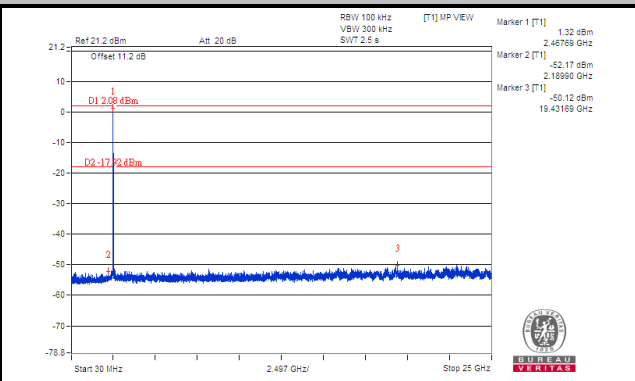
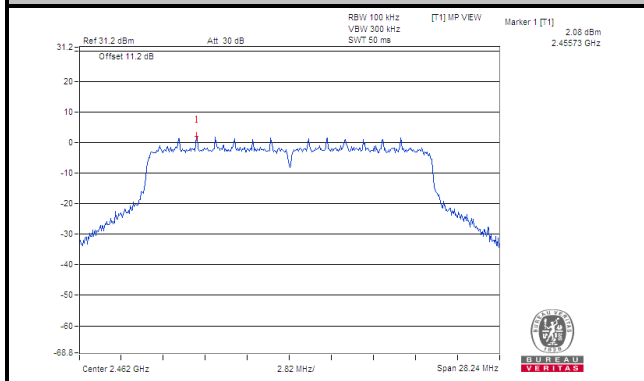

## Ch 12

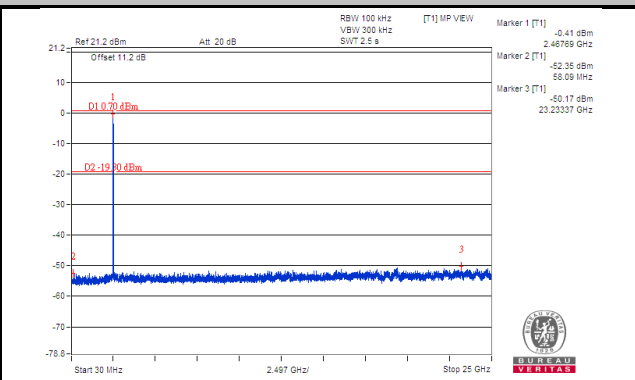
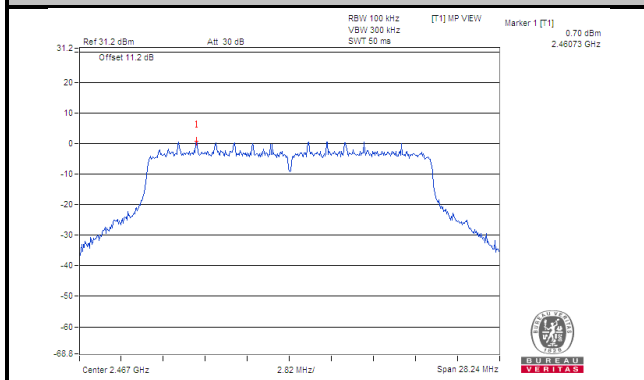

### Ch 13

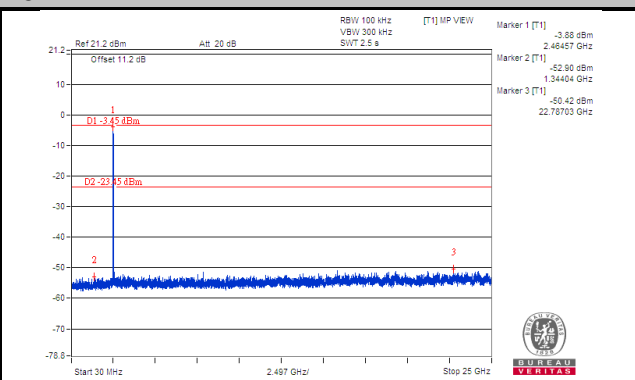
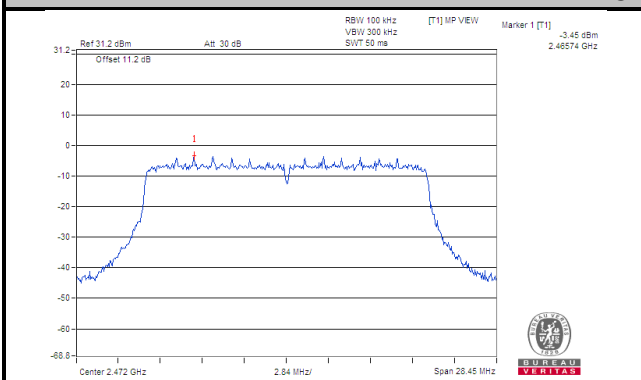

### Ch 1 Band Edge

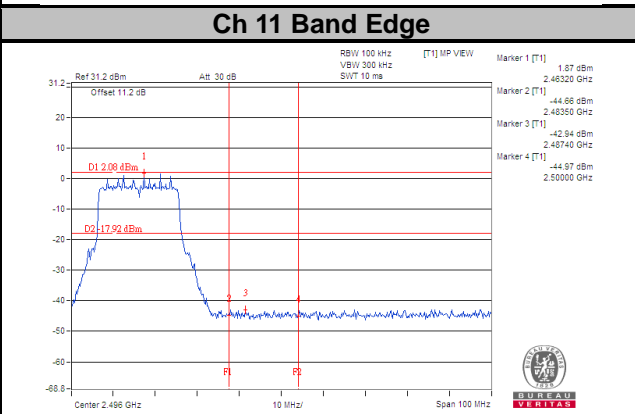
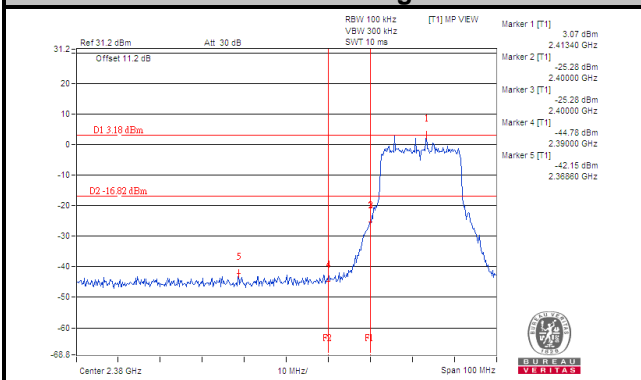

### Ch 12 Band Edge

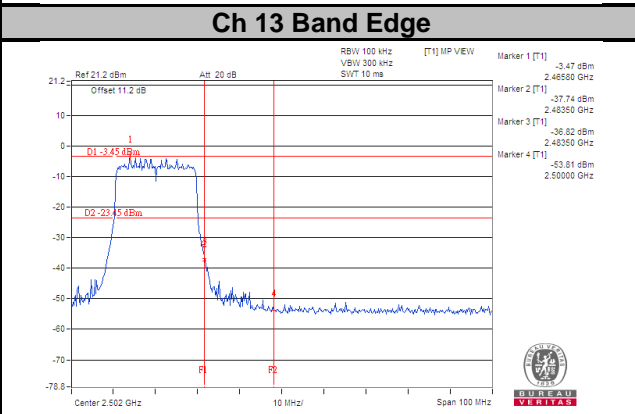
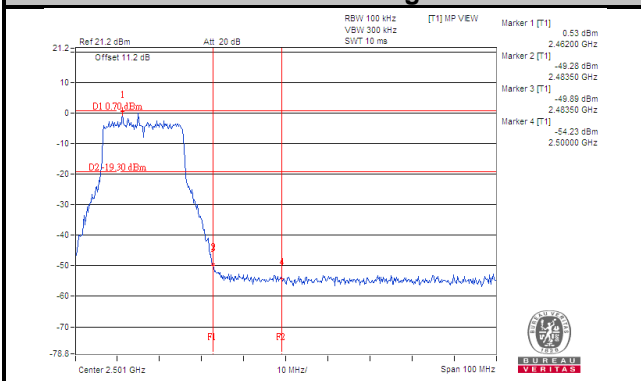

**802.11ax (HE40)**  
**CHAIN 0**

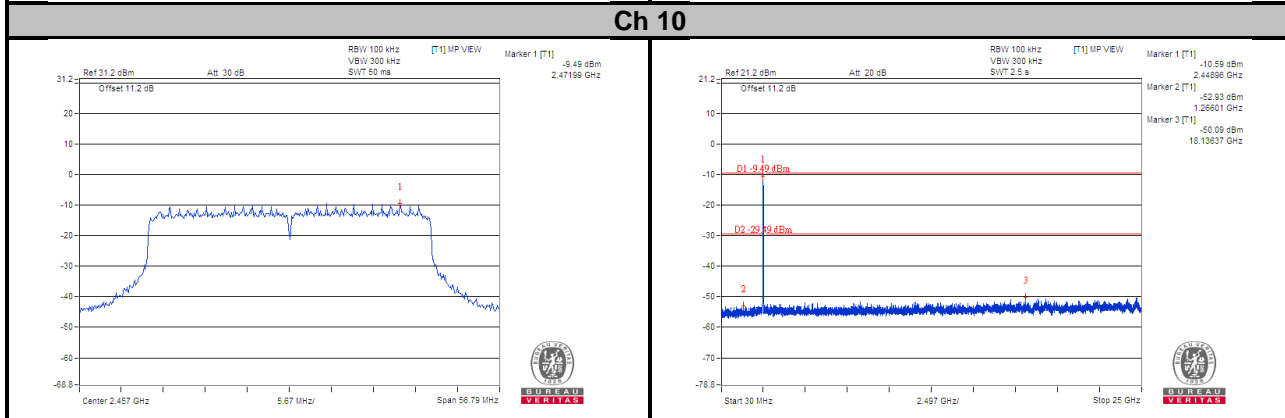
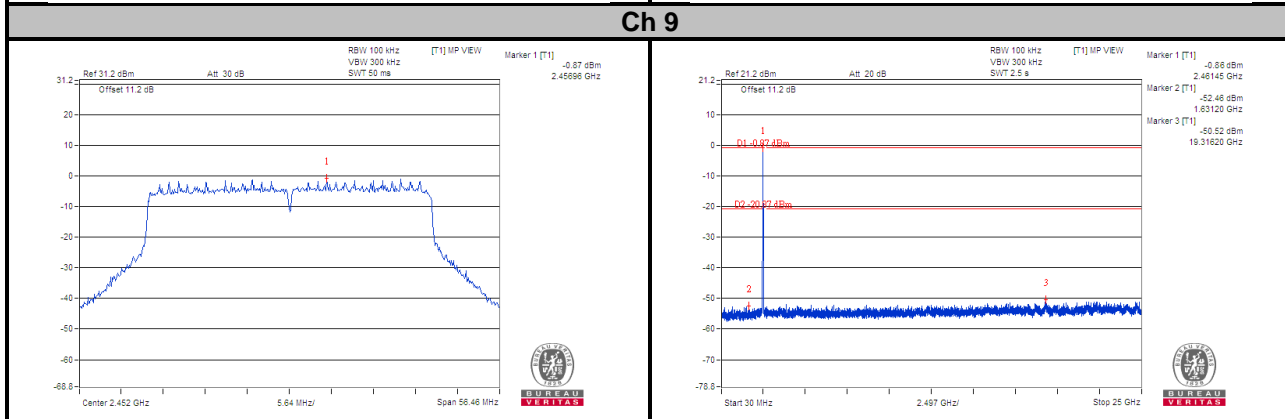
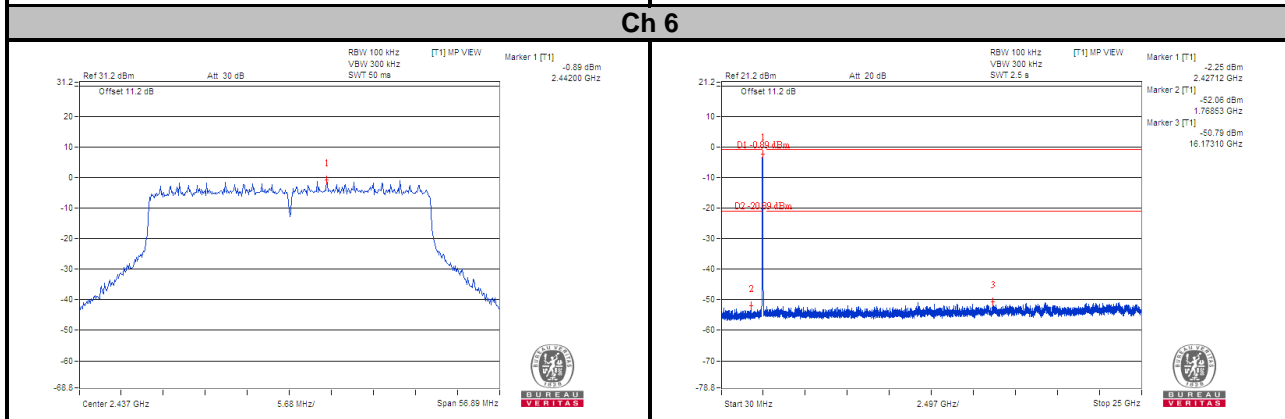
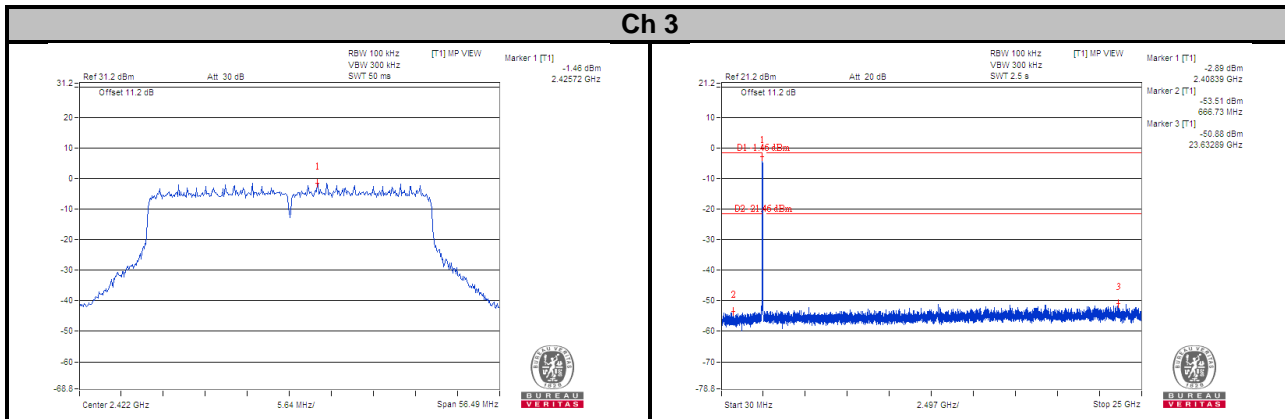

### Ch 11

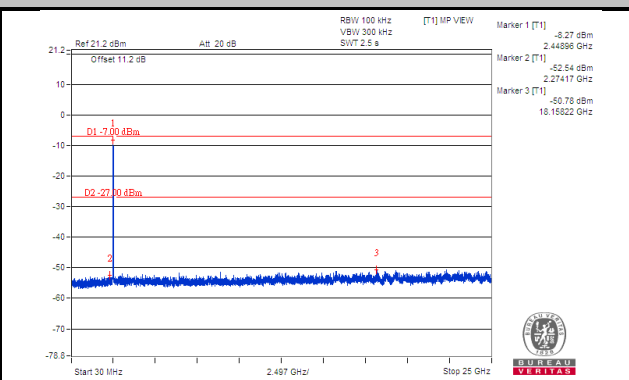
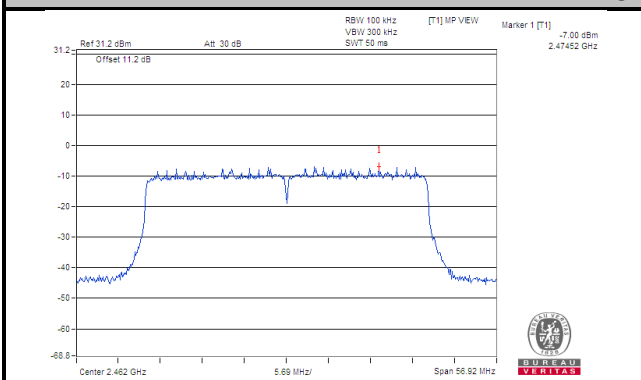

### Ch 3 Band Edge

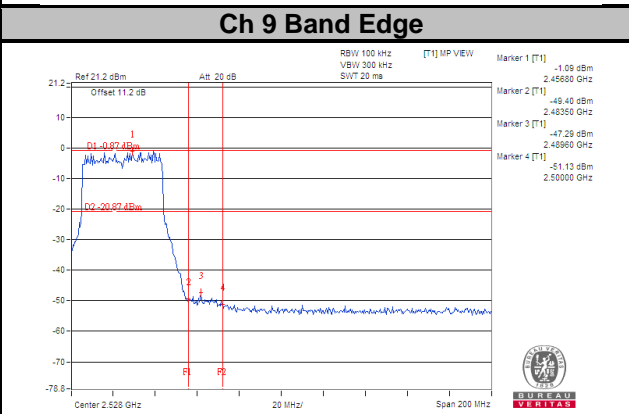
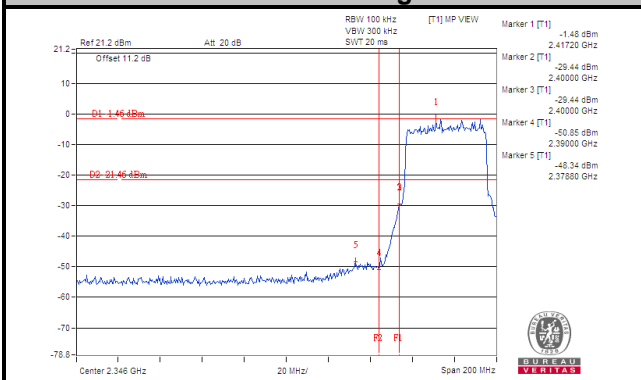

### Ch 10 Band Edge

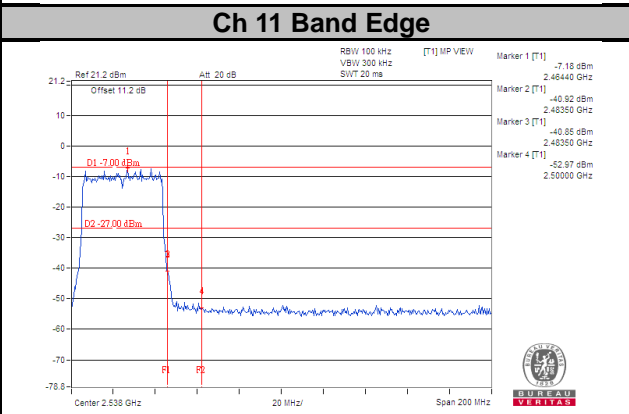
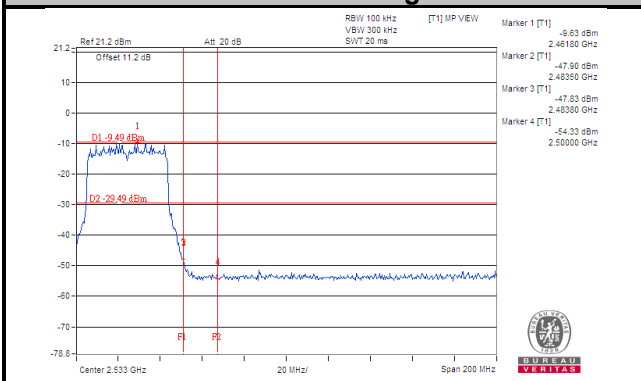

### Ch 11 Band Edge

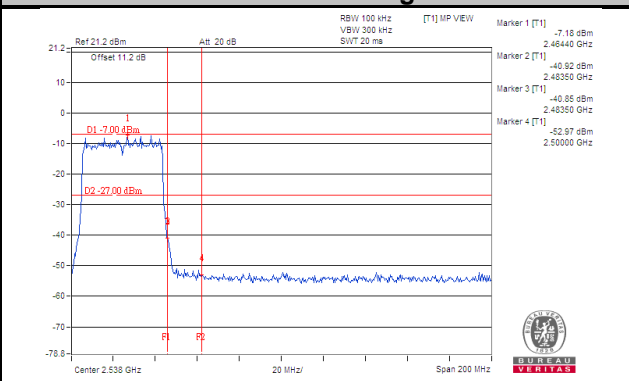
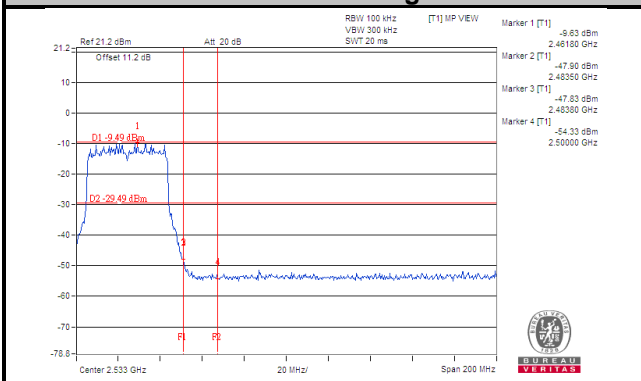



# CHAIN 1

## Ch 3

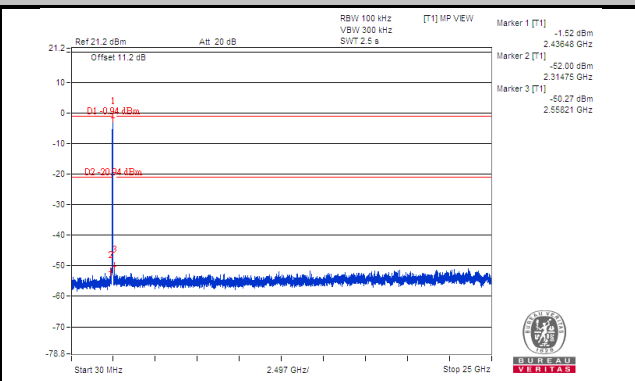
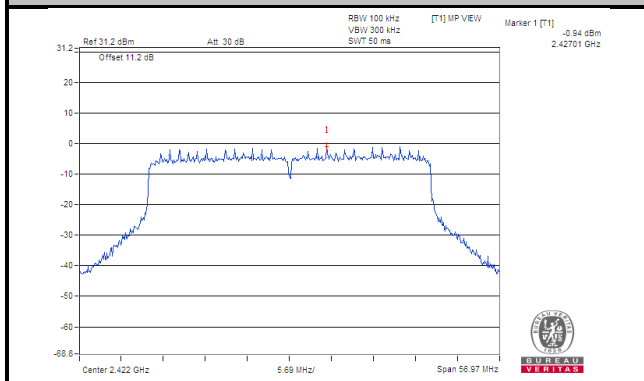

## Ch 6

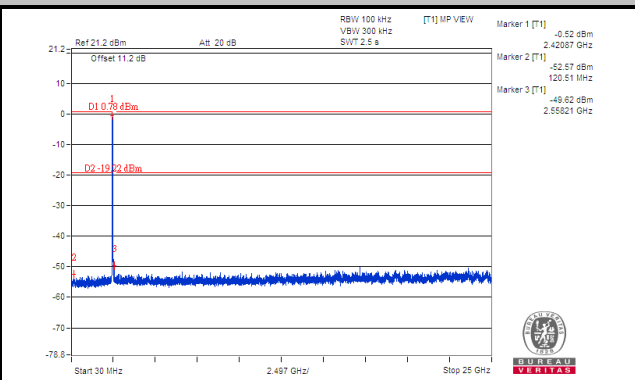
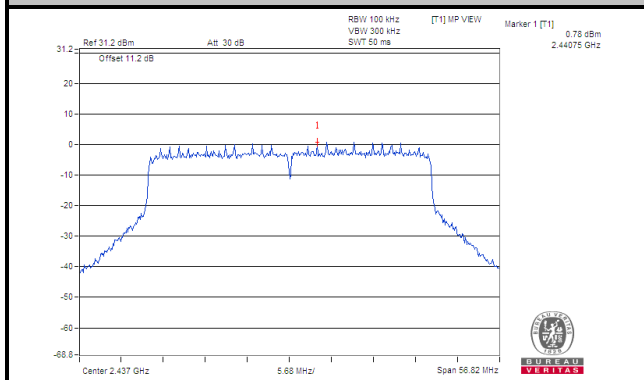

## Ch 9

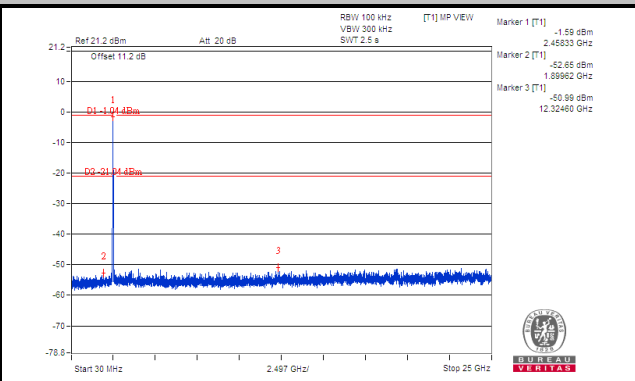
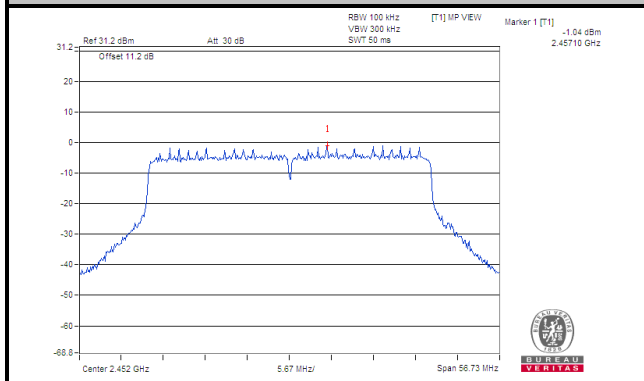

## Ch 10

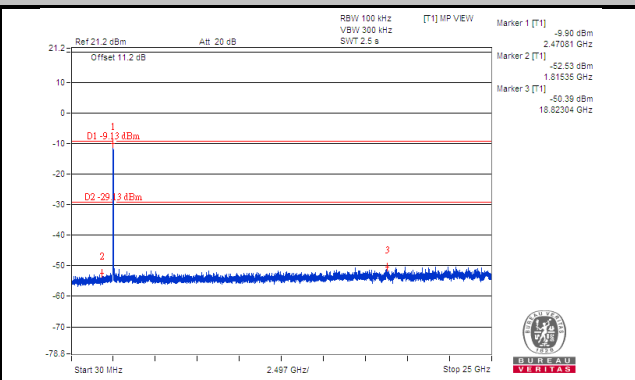
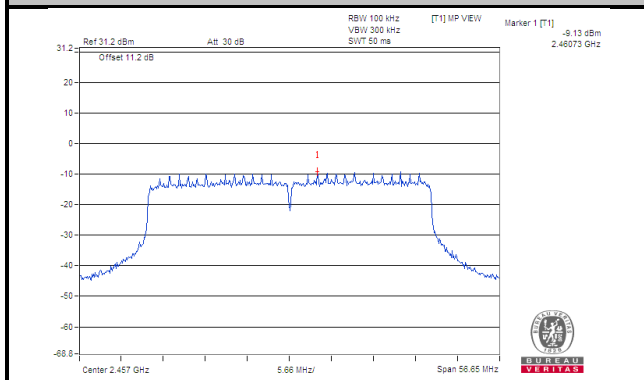

### Ch 11

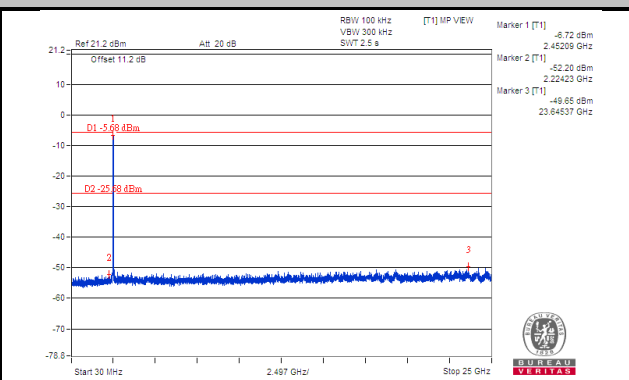
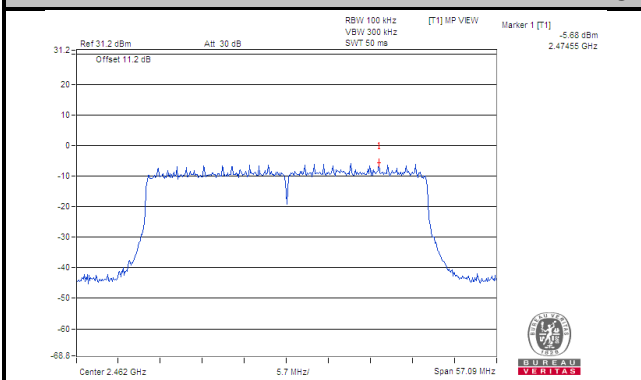

### Ch 3 Band Edge

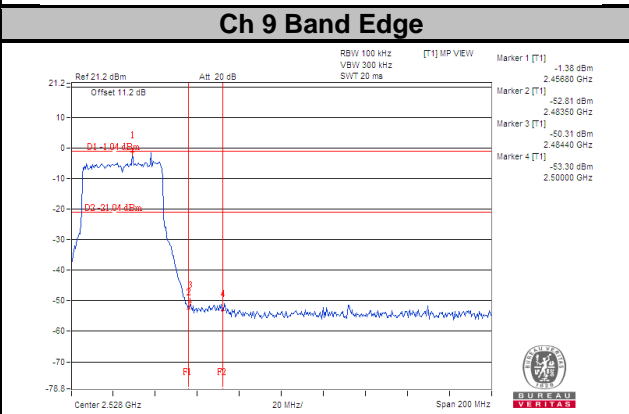
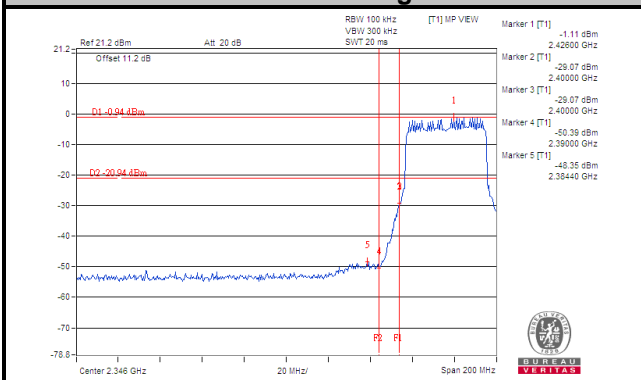

### Ch 10 Band Edge

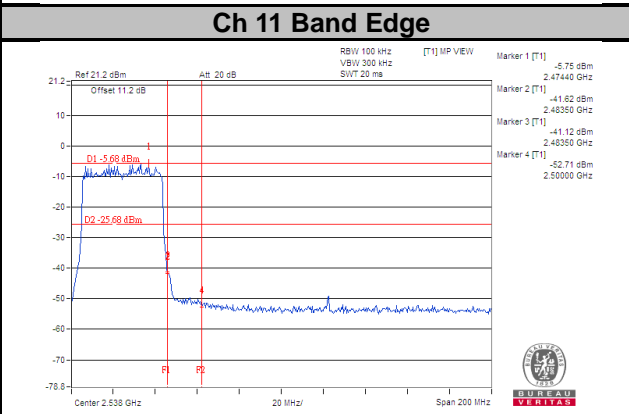
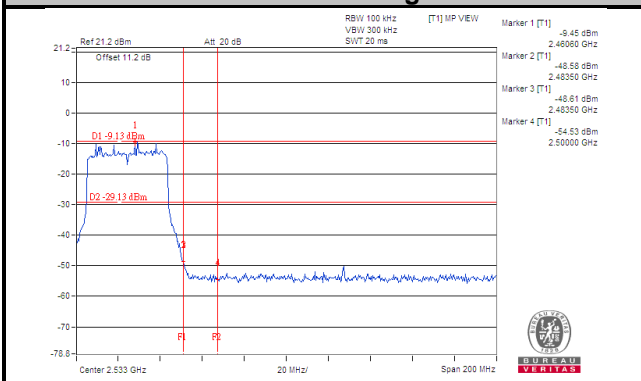

## 5 Pictures of Test Arrangements

Please refer to the attached file (Test Setup Photo).

## Appendix – Information of the Testing Laboratories

We, Bureau Veritas Consumer Products Services (H.K.) Ltd., Taoyuan Branch, were founded in 1988 to provide our best service in EMC, Radio, Telecom and Safety consultation. Our laboratories are FCC recognized accredited test firms and accredited according to ISO/IEC 17025.

If you have any comments, please feel free to contact us at the following:

**Lin Kou EMC/RF Lab**

Tel: 886-2-26052180

Fax: 886-2-26051924

**Hsin Chu EMC/RF/Telecom Lab**

Tel: 886-3-6668565

Fax: 886-3-6668323

**Hwa Ya EMC/RF/Safety Lab**

Tel: 886-3-3183232

Fax: 886-3-3270892

**Email:** [service.adt@tw.bureauveritas.com](mailto:service.adt@tw.bureauveritas.com)

**Web Site:** [www.bureauveritas-adt.com](http://www.bureauveritas-adt.com)

The address and road map of all our labs can be found in our web site also.

--- END ---