

FCC Test Report

Report No.: RF180518C15

FCC ID: I4L-BM25SD

Test Model: BM25

Received Date: May 18, 2018

Test Date: Jun. 06, 2018 ~ Jul. 09, 2018

Issued Date: Jul. 20, 2018

Applicant: Micro-Star INT'L CO., LTD.

Address: No.69, Lide St., Zhonghe Dist., New Taipei City 235, Taiwan (R.O.C)

Issued By: Bureau Veritas Consumer Products Services (H.K.) Ltd., Taoyuan Branch

Lab Address: No. 47-2, 14th Ling, Chia Pau Vil., Lin Kou Dist., New Taipei City, Taiwan (R.O.C)

Test Location: No.19, Hwa Ya 2nd Rd., Wen Hwa Vil., Kwei Shan Dist., Taoyuan City 33383, Taiwan, R.O.C.

**FCC Registration /
Designation Number:** 788550 / TW0003



This report is for your exclusive use. Any copying or replication of this report to or for any other person or entity, or use of our name or trademark, is permitted only with our prior written permission. This report sets forth our findings solely with respect to the test samples identified herein. The results set forth in this report are not indicative or representative of the quality or characteristics of the lot from which a test sample was taken or any similar or identical product unless specifically and expressly noted. Our report includes all of the tests requested by you and the results thereof based upon the information that you provided to us. You have 60 days from date of issuance of this report to notify us of any material error or omission caused by our negligence, provided, however, that such notice shall be in writing and shall specifically address the issue you wish to raise. A failure to raise such issue within the prescribed time shall constitute your unqualified acceptance of the completeness of this report, the tests conducted and the correctness of the report contents. Unless specifically mentioned, the uncertainty of measurement has been explicitly taken into account to declare the compliance or non-compliance to the specification. The report must not be used by the client to claim product certification, approval, or endorsement by TAF or any government agencies.

Table of Contents

Release Control Record	4
1 Certificate of Conformity	5
2 Summary of Test Results	6
2.1 Measurement Uncertainty	6
2.2 Modification Record.....	6
3 General Information	7
3.1 General Description of EUT	7
3.2 Description of Test Modes	8
3.2.1 Test Mode Applicability and Tested Channel Detail	9
3.3 Duty Cycle of Test Signal	11
3.4 Description of Support Units.....	12
3.4.1 Configuration of System under Test.....	12
3.5 General Description of Applied Standards	12
4 Test Types and Results	13
4.1 Radiated Emission and Bandedge Measurement	13
4.1.1 Limits of Radiated Emission and Bandedge Measurement	13
4.1.2 Test Instruments	14
4.1.3 Test Procedures.....	16
4.1.4 Deviation from Test Standard.....	17
4.1.5 Test Set Up	18
4.1.6 EUT Operating Conditions	19
4.1.7 Test Results	20
4.2 Conducted Emission Measurement	40
4.2.1 Limits of Conducted Emission Measurement	40
4.2.2 Test Instruments	40
4.2.3 Test Procedures.....	41
4.2.4 Deviation from Test Standard.....	41
4.2.5 Test Setup.....	41
4.2.6 EUT Operating Conditions	41
4.2.7 Test Results	42
4.3 6 dB Bandwidth Measurement	44
4.3.1 Limits of 6 dB Bandwidth Measurement.....	44
4.3.2 Test Setup.....	44
4.3.3 Test Instruments	44
4.3.4 Test Procedure	44
4.3.5 Deviation from Test Standard.....	44
4.3.6 EUT Operating Conditions	44
4.3.7 Test Result	45
4.4 Occupied Bandwidth Measurement	47
4.4.1 Test Setup.....	47
4.4.2 Test Instruments	47
4.4.3 Test Procedure	47
4.4.4 Deviation from Test Standard.....	47
4.4.5 EUT Operating Conditions	47
4.4.6 Test Results	48
4.5 Conducted Output Power Measurement	50
4.5.1 Limits of Conducted Output Power Measurement.....	50
4.5.2 Test Setup.....	50
4.5.3 Test Instruments	50
4.5.4 Test Procedures.....	50
4.5.5 Deviation from Test Standard.....	50
4.5.6 EUT Operating Conditions	50
4.5.7 Test Results	51

4.6	Power Spectral Density Measurement	52
4.6.1	Limits of Power Spectral Density Measurement	52
4.6.2	Test Setup	52
4.6.3	Test Instruments	52
4.6.4	Test Procedure	52
4.6.5	Deviation from Test Standard	52
4.6.6	EUT Operating Condition	52
4.6.7	Test Results	53
4.7	Conducted Out of Band Emission Measurement	55
4.7.1	Limits of Conducted Out of Band Emission Measurement	55
4.7.2	Test Setup	55
4.7.3	Test Instruments	55
4.7.4	Test Procedure	55
4.7.5	Deviation from Test Standard	55
4.7.6	EUT Operating Condition	55
4.7.7	Test Results	56
5	Pictures of Test Arrangements	62
	Appendix – Information on the Testing Laboratories	63

Release Control Record

Issue No.	Description	Date Issued
RF180518C15	Original Release	Jul. 20, 2018

1 Certificate of Conformity

Product: 802.11a/b/g/n/ac + BT 4.2 Module

Brand: MSI

Test Model: BM25

Sample Status: Identical Prototype

Applicant: Micro-Star INT'L CO., LTD.

Test Date: Jun. 06, 2018 ~ Jul. 09, 2018

Standards: 47 CFR FCC Part 15, Subpart C (Section 15.247)
ANSI C63.10:2013

The above equipment has been tested by **Bureau Veritas Consumer Products Services (H.K.) Ltd., Taoyuan Branch**, and found compliance with the requirement of the above standards. The test record, data evaluation & Equipment Under Test (EUT) configurations represented herein are true and accurate accounts of the measurements of the sample's RF characteristics under the conditions specified in this report.

Prepared by : , **Date:** Jul. 20, 2018
Rona Chen / Specialist

Approved by : , **Date:** Jul. 20, 2018
Dylan Chiou / Project Engineer

2 Summary of Test Results

47 CFR FCC Part 15, Subpart C (Section 15.247)			
FCC Clause	Test Item	Result	Remarks
15.207	AC Power Conducted Emission	Pass	Meet the requirement of limit. Minimum passing margin is -30.78 dB at 9.90154 MHz.
15.205 / 15.209 / 15.247(d)	Radiated Emissions and Band Edge Measurement	Pass	Meet the requirement of limit. Minimum passing margin is -0.56 dB at 2483.52 MHz.
15.247(d)	Antenna Port Emission	Pass	Meet the requirement of limit.
15.247(a)(2)	6 dB Bandwidth	Pass	Meet the requirement of limit.
---	Occupied Bandwidth Measurement	Pass	Reference only
15.247(b)	Conducted power	Pass	Meet the requirement of limit.
15.247(e)	Power Spectral Density	Pass	Meet the requirement of limit.
15.203	Antenna Requirement	Pass	No antenna connector is used.

2.1 Measurement Uncertainty

Where relevant, the following measurement uncertainty levels have been estimated for tests performed on the EUT as specified in CISPR 16-4-2:

Measurement	Frequency	Expanded Uncertainty (k=2) (±)
Conducted Emissions at mains ports	150 kHz ~ 30 MHz	2.44 dB
Radiated Emissions up to 1 GHz	30 MHz ~ 200 MHz	2.93 dB
	200 MHz ~ 1000 MHz	2.95 dB
Radiated Emissions above 1 GHz	1 GHz ~ 18 GHz	2.26 dB
	18 GHz ~ 40 GHz	1.94 dB

2.2 Modification Record

There were no modifications required for compliance.

3 General Information

3.1 General Description of EUT

Product	802.11a/b/g/n/ac + BT 4.2 Module
Brand	MSI
Test Model	BM25
Status of EUT	Identical Prototype
Power Supply Rating	3.6 Vdc (Host equipment)
Modulation Type	CCK, DQPSK, DBPSK for DSSS 64QAM, 16QAM, QPSK, BPSK for OFDM
Modulation Technology	DSSS, OFDM
Transfer Rate	802.11b: 11.0 / 5.5 / 2.0 / 1.0 Mbps 802.11g: 54.0 / 48.0 / 36.0 / 24.0 / 18.0 / 12.0 / 9.0 / 6.0 Mbps 802.11n: up to 72.2 Mbps
Operating Frequency	2412 ~ 2462 MHz
Number of Channel	11 for 802.11b, 802.11g, 802.11n (HT20)
Output Power	220.8 mW
Antenna Type	Dipole antenna with 4.96 dBi gain PIFA antenna with 3.63 dBi gain
Antenna Connector	N/A
Accessory Device	N/A
Data Cable Supplied	N/A

Note:

1. The EUT provides 1 completed transmitter and 1 receiver.

Modulation Mode	Tx Function
802.11b	1TX
802.11g	1TX
802.11n (HT20)	1TX

2. The above EUT information is declared by manufacturer and for more detailed features description, please refers to the manufacturer's specifications or user's manual.

3.2 Description of Test Modes

11 channels are provided for 802.11b, 802.11g and 802.11n (HT20):

Channel	Frequency (MHz)	Channel	Frequency (MHz)
1	2412	7	2442
2	2417	8	2447
3	2422	9	2452
4	2427	10	2457
5	2432	11	2462
6	2437		

3.2.1 Test Mode Applicability and Tested Channel Detail

EUT Configure Mode	Applicable To				Description
	RE \geq 1G	RE<1G	PLC	APCM	
A	√	√	√	-	EUT with Dipole Antenna
B	√	√	-	√	EUT with PIFA Antenna

Where **RE \geq 1G**: Radiated Emission above 1 GHz **RE<1G**: Radiated Emission below 1 GHz
PLC: Power Line Conducted Emission **APCM**: Antenna Port Conducted Measurement

NOTE:

1. The EUT had been pre-tested on the positioned of each 3 axis. The worst case was found when positioned on **Z-plane**.
2. "-" means no effect.

Radiated Emission Test (Above 1 GHz):

- Pre-Scan has been conducted to determine the worst-case mode from all possible combinations between available modulations, data rates and antenna ports (if EUT with antenna diversity architecture).
- Following channel(s) was (were) selected for the final test as listed below.

EUT Configure Mode	Mode	Available Channel	Tested Channel	Modulation Technology	Modulation Type	Data Rate (Mbps)
A, B	802.11b	1 to 11	1, 6, 11	DSSS	DBPSK	1.0
	802.11g	1 to 11	1, 6, 11	OFDM	BPSK	6.0
	802.11n (HT20)	1 to 11	1, 6, 11	OFDM	BPSK	6.5

Radiated Emission Test (Below 1 GHz):

- Pre-Scan has been conducted to determine the worst-case mode from all possible combinations between available modulations, data rates and antenna ports (if EUT with antenna diversity architecture).
- Following channel(s) was (were) selected for the final test as listed below.

EUT Configure Mode	Mode	Available Channel	Tested Channel	Modulation Technology	Modulation Type	Data Rate (Mbps)
A	802.11n (HT20)	1 to 11	11	OFDM	BPSK	6.5
B	802.11g	1 to 11	11	OFDM	BPSK	6.0

Power Line Conducted Emission Test:

- Pre-Scan has been conducted to determine the worst-case mode from all possible combinations between available modulations, data rates and antenna ports (if EUT with antenna diversity architecture).
- Following channel(s) was (were) selected for the final test as listed below.

EUT Configure Mode	Mode	Available Channel	Tested Channel	Modulation Technology	Modulation Type	Data Rate (Mbps)
A	802.11n (HT20)	1 to 11	11	OFDM	BPSK	6.5

Bandedge Measurement:

- Pre-Scan has been conducted to determine the worst-case mode from all possible combinations between available modulations, data rates and antenna ports (if EUT with antenna diversity architecture).
- Following channel(s) was (were) selected for the final test as listed below.

EUT Configure Mode	Mode	Available Channel	Tested Channel	Modulation Technology	Modulation Type	Data Rate (Mbps)
A, B	802.11b	1 to 11	1, 11	DSSS	DBPSK	1.0
	802.11g	1 to 11	1, 11	OFDM	BPSK	6.0
	802.11n (HT20)	1 to 11	1, 11	OFDM	BPSK	6.5

Antenna Port Conducted Measurement:

- This item includes all test value of each mode, but only includes spectrum plot of worst value of each mode.
- Pre-Scan has been conducted to determine the worst-case mode from all possible combinations between available modulations, data rates and antenna ports (if EUT with antenna diversity architecture).
- Following channel(s) was (were) selected for the final test as listed below.

EUT Configure Mode	Mode	Available Channel	Tested Channel	Modulation Technology	Modulation Type	Data Rate (Mbps)
B	802.11b	1 to 11	1, 6, 11	DSSS	DBPSK	1.0
	802.11g	1 to 11	1, 6, 11	OFDM	BPSK	6.0
	802.11n (HT20)	1 to 11	1, 6, 11	OFDM	BPSK	6.5

Test Condition:

Applicable To	Environmental Conditions	Input Power	Tested by
RE \geq 1G	25 deg. C, 65 % RH	120 Vac, 60 Hz	Jisyong Wang
RE<1G	25 deg. C, 65 % RH	120 Vac, 60 Hz	Jisyong Wang
PLC	25 deg. C, 65 % RH	120 Vac, 60 Hz	Getaz Yang
APCM	25 deg. C, 65 % RH	3.6 Vdc	Gavin Wu

3.3 Duty Cycle of Test Signal

802.11b: Duty cycle of test signal is $\geq 98\%$, duty factor is not required.

802.11g: Duty cycle = $1.42/1.532 = 0.927$, Duty factor = $10 * \log(1/0.927) = 0.33$

802.11n (HT20): Duty cycle = $1.335/1.437 = 0.929$, Duty factor = $10 * \log(1/0.929) = 0.32$

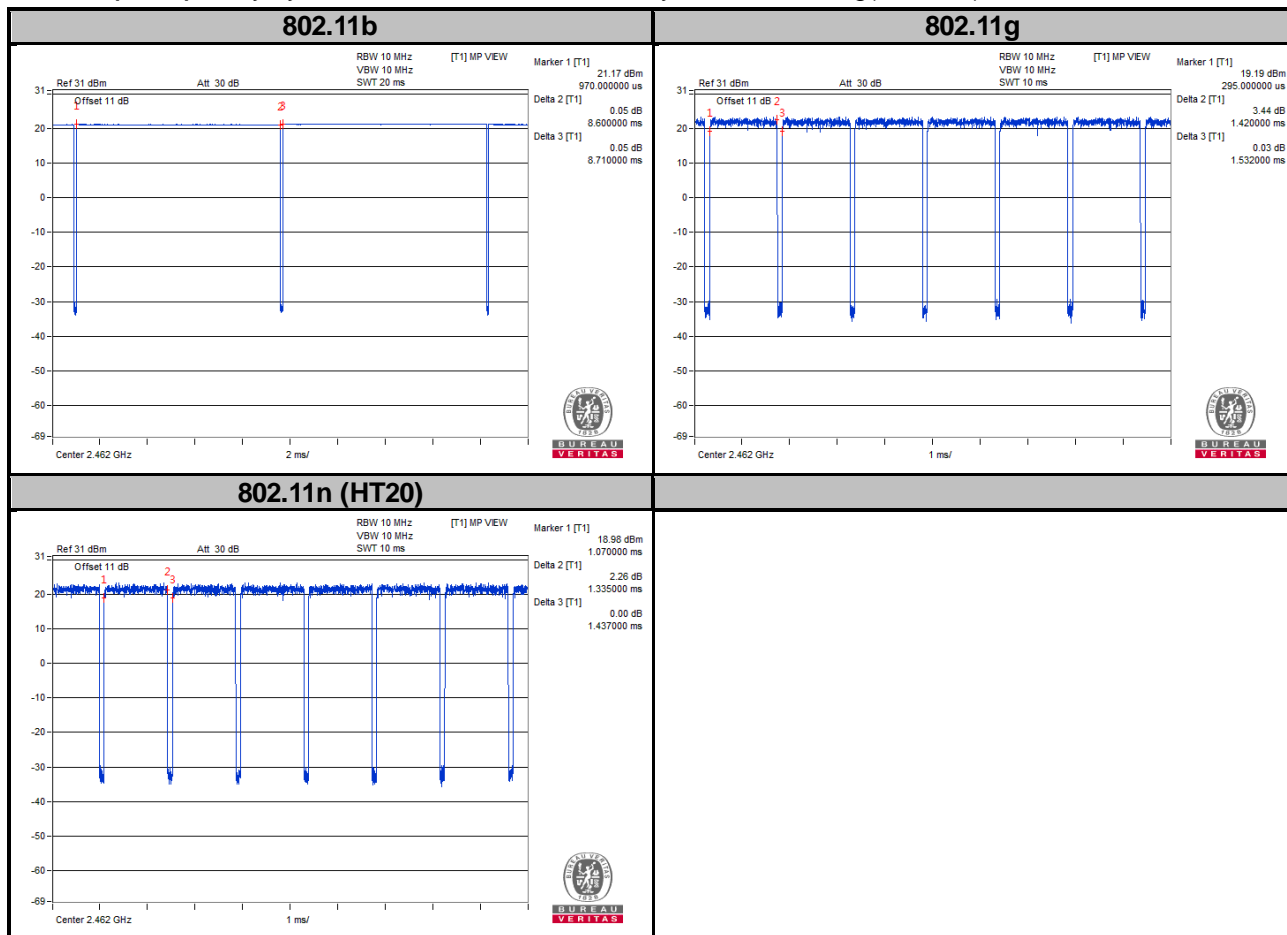

3.4 Description of Support Units

The EUT has been tested as an independent unit together with other necessary accessories or support units. The following support units or accessories were used to form a representative test configuration during the tests.

No.	Product	Brand	Model No.	Serial No.	FCC ID
1.	DC Power Supply	Topward	33010D	807748	N/A
2.	Mouse	DELL	MS111-P	CN-011D3V-71581-1CJ-09 2S	FCC DoC Approved
3.	Keyboard	DELL	KB4021	CN-05V23T-71581-1AK-01 Q2-A01	FCC DoC Approved
4.	Monitor	DELL	U2410	CN-0J257M-72872-0A6-08 JL	FCC DoC Approved
5.	USB Dongle	Transcend	N/A	N/A	N/A

No.	Signal Cable Description of The Above Support Units
1.	N/A
2.	1.8m shielded cable w/o core
3.	1.8m shielded cable w/o core
4.	1.2m shielded cable w/o core

Note:

1. All power cords of the above support units are non-shielded (1.8m).

3.4.1 Configuration of System under Test

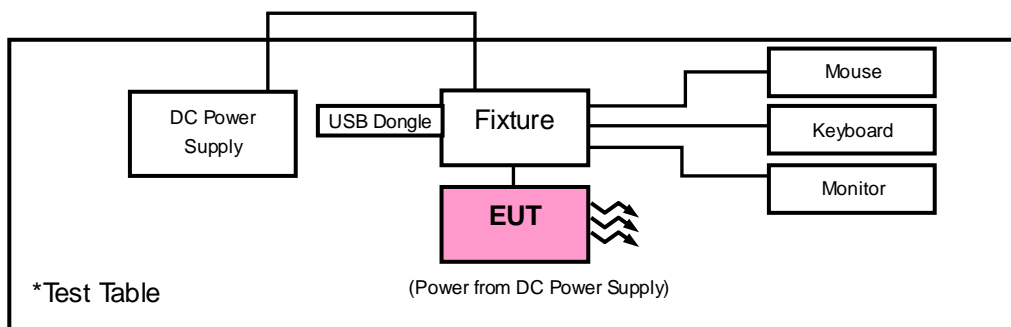

3.5 General Description of Applied Standards

The EUT is a RF Product. According to the specifications of the manufacturer, it must comply with the requirements of the following standards:

FCC Part 15, Subpart C (15.247)

KDB 558074 D01 DTS Meas Guidance v04

ANSI C63.10-2013

All test items have been performed and recorded as per the above standards.

4 Test Types and Results

4.1 Radiated Emission and Bandedge Measurement

4.1.1 Limits of Radiated Emission and Bandedge Measurement

Radiated emissions which fall in the restricted bands must comply with the radiated emission limits specified as below table. Other emissions shall be at least 20 dB below the highest level of the desired power:

Frequencies (MHz)	Field Strength (microvolts/meter)	Measurement Distance (meters)
0.009 ~ 0.490	2400/F (kHz)	300
0.490 ~ 1.705	24000/F (kHz)	30
1.705 ~ 30.0	30	30
30 ~ 88	100	3
88 ~ 216	150	3
216 ~ 960	200	3
Above 960	500	3

NOTE:

1. The lower limit shall apply at the transition frequencies.
2. Emission level (dBuV/m) = 20 log Emission level (uV/m).
3. For frequencies above 1000 MHz, the field strength limits are based on average detector, however, the peak field strength of any emission shall not exceed the maximum permitted average limits, specified above by more than 20 dB under any condition of modulation.

4.1.2 Test Instruments

Description & Manufacturer	Model No.	Serial No.	Date Of Calibration	Due Date Of Calibration
Test Receiver Agilent	N9038A	MY51210203	Mar. 16, 2018	Mar. 15, 2019
Spectrum Analyzer Agilent	N9010A	MY52220314	Nov. 24, 2017	Nov. 23, 2018
Spectrum Analyzer ROHDE & SCHWARZ	FSU43	101261	Jan. 11, 2018	Jan. 10, 2019
Double Ridge Guide Horn Antenna EMCO	3115	5619	Nov. 30, 2017	Nov. 29, 2018
BILOG Antenna SCHWARZBECK	VULB 9168	9168-153	Dec. 06, 2017	Dec. 05, 2018
Fixed Attenuator Mini-Circuits	MDCS18N-10	MDCS18N-10-01	Apr. 16, 2018	Apr. 15, 2019
Loop Antenna	EM-6879	269	Aug. 11, 2017	Aug. 10, 2018
Preamplifier EMCI	EMC001340	980201	Nov. 01, 2017	Oct. 30, 2018
Preamplifier EMCI	EMC 012645	980115	Oct. 20, 2017	Oct. 19, 2018
Preamplifier EMCI	EMC 184045	980116	Oct. 20, 2017	Oct. 19, 2018
Preamplifier EMCI	EMC 330H	980112	Oct. 13, 2017	Oct. 12, 2018
Power Meter Anritsu	ML2495A	1012010	Aug. 15, 2017	Aug. 14, 2018
Power Sensor Anritsu	MA2411B	1315050	Aug. 15, 2017	Aug. 14, 2018
RF signal cable ETS-LINDGREN	5D-FB	Cable-CH1-01(RFC-SM S-100-SMS-120+RFC-S MS-100-SMS-400)	Jun. 23, 2017 Jun. 19, 2018	Jun. 22, 2018 Jun. 18, 2019
RF Coaxial Cable HUBER+SUHNNER	EMC104-SM-SM- 8000&3000	140811+170717	Oct. 20, 2017	Oct. 19, 2018
RF Coaxial Cable HUBER+SUHNNER	SUCOFLEX 104	EMC104-SM-SM-1000(1 40807)	Oct. 20, 2017	Oct. 19, 2018
RF Coaxial Cable Woken	8D-FB	Cable-Ch10-01	Oct. 20, 2017	Oct. 19, 2018
Software BV ADT	E3 6.120103	NA	NA	NA
Antenna Tower MF	MFA-440H	NA	NA	NA
Turn Table MF	MFT-201SS	NA	NA	NA
Antenna Tower & Turn Table Controller MF	MF-7802	NA	NA	NA
2WAY DIV Worken	2-18GHz 2Way SMA Fwd.:30W/Rev.:2 W Isolated Power	COM412W5E2	May 15, 2018	May 14, 2019

- Note:
1. The calibration interval of the above test instruments is 12 months and the calibrations are traceable to NML/ROC and NIST/USA.
 2. The test was performed in HwaYa Chamber 10.
 3. The horn antenna and preamplifier (model: EMC 184045) are used only for the measurement of emission frequency above 1 GHz if tested.
 4. The IC Site Registration No. is IC7450F-10.

4.1.3 Test Procedures

For Radiated Emission below 30 MHz

- a. The EUT was placed on the top of a rotating table 0.8 meters above the ground at a 3 meter chamber room. The table was rotated 360 degrees to determine the position of the highest radiation.
- b. The EUT was set 3 meters away from the interference-receiving antenna, which was mounted on the top of a variable-height antenna tower.
- c. Parallel, perpendicular, and ground-parallel orientations of the antenna are set to make the measurement.
- d. For each suspected emission, the EUT was arranged to its worst case and the rotatable table was turned from 0 degrees to 360 degrees to find the maximum reading.
- e. The test-receiver system was set to Quasi-Peak Detect Function and Specified Bandwidth with Maximum Hold Mode.

Note:

1. The resolution bandwidth and video bandwidth of test receiver/spectrum analyzer is 9 kHz at frequency below 30 MHz.

For Radiated Emission above 30 MHz

- a. The EUT was placed on the top of a rotating table 0.8 meters (for 30 MHz ~ 1 GHz) / 1.5 meters (for above 1 GHz) above the ground at 3 meter chamber room for test. The table was rotated 360 degrees to determine the position of the highest radiation.
- b. The EUT was set 3 meters away from the interference-receiving antenna, which was mounted on the top of a variable-height antenna tower.
- c. The height of antenna is varied from one meter to four meters above the ground to determine the maximum value of the field strength. Both horizontal and vertical polarizations of the antenna are set to make the measurement.
- d. For each suspected emission, the EUT was arranged to its worst case and then the antenna was tuned to heights from 1 meter to 4 meters and the rotatable table was turned from 0 degrees to 360 degrees to find the maximum reading.
- e. The test-receiver system was set to quasi-peak detect function and specified bandwidth with maximum hold mode when the test frequency is below 1 GHz.
- f. The test-receiver system was set to peak and average detected function and specified bandwidth with maximum hold mode when the test frequency is above 1 GHz. If the peak reading value also meets average limit, measurement with the average detector is unnecessary.

Note:

1. The resolution bandwidth and video bandwidth of test receiver/spectrum analyzer is 120 kHz for Quasi-peak detection (QP) at frequency below 1 GHz.
2. The resolution bandwidth of test receiver/spectrum analyzer is 1 MHz and the video bandwidth is 3 MHz for Peak detection (PK) at frequency above 1 GHz.
3. The resolution bandwidth of test receiver/spectrum analyzer is 1 MHz and the video bandwidth is $\geq 1/T$ (Duty cycle < 98 %) or 10 Hz (Duty cycle ≥ 98 %) for Average detection (AV) at frequency above 1 GHz.
(11b: RBW = 1 MHz, VBW = 300 Hz ; 11g: RBW = 1 MHz, VBW = 1 kHz ;
11n (HT20): RBW = 1 MHz, VBW = 1 kHz)
4. All modes of operation were investigated and the worst-case emissions are reported.

4.1.4 Deviation from Test Standard

No deviation.

4.1.5 Test Set Up

<Radiated Emission below 30 MHz>

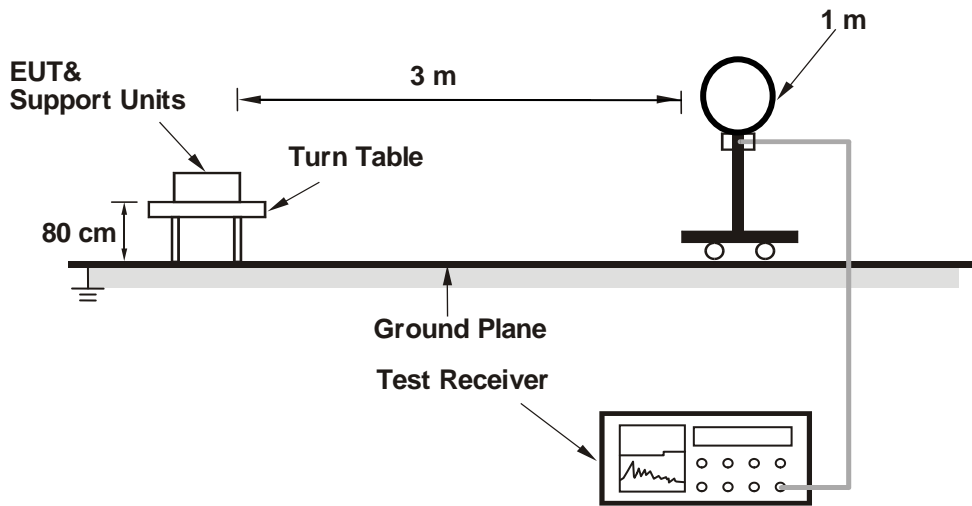

<Radiated Emission 30 MHz to 1 GHz>

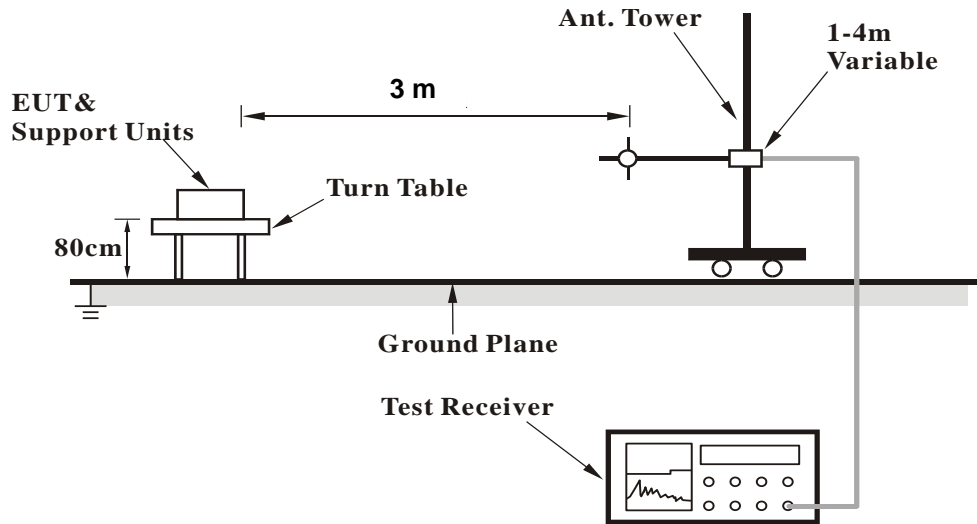

<Radiated Emission above 1 GHz>

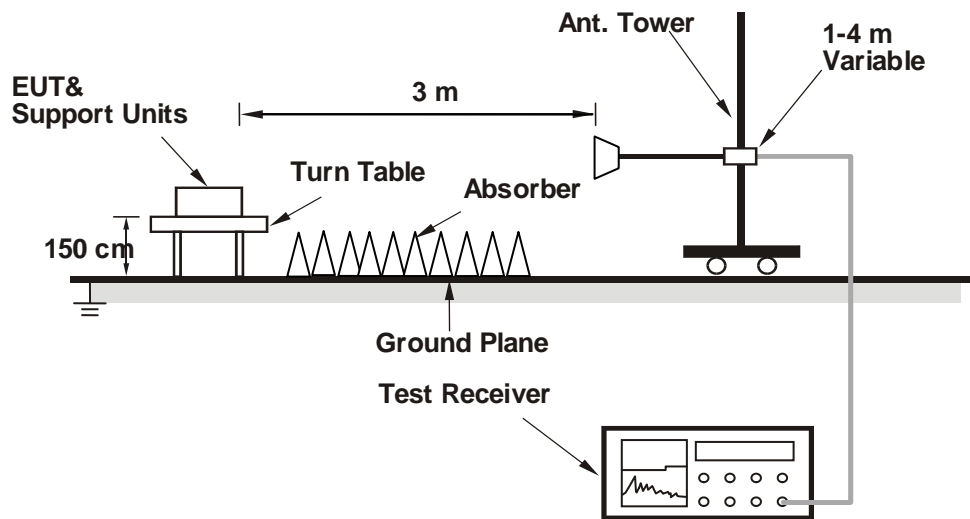

For the actual test configuration, please refer to the attached file (Test Setup Photo).

4.1.6 EUT Operating Conditions

- a. Placed the EUT on a testing table.
- b. Use the software to control the EUT under transmission condition continuously at specific channel frequency.

4.1.7 Test Results

Above 1 GHz Data :

Mode A

802.11b

EUT Test Condition		Measurement Detail	
Channel	Channel 1	Frequency Range	1 GHz ~ 25 GHz
Input Power	120 Vac, 60 Hz	Detector Function	Peak (PK) Average (AV)
Environmental Conditions	25 deg. C, 65 % RH	Tested By	Jisyong Wang

Antenna Polarity & Test Distance: Horizontal at 3 m										
Frequency (MHz)	Emission Level (dBuV/m)	Read Level (dBuV)	Limit (dBuV/m)	Margin (dB)	Antenna Factor (dB/m)	Cable Loss (dB)	Preamp Factor (dB)	Antenna Height (cm)	Table Angle (Degree)	Remark
2389.94	41.98	47.98	54	-12.02	27.16	4.36	37.52	116	248	Average
2389.94	54.08	60.08	74	-19.92	27.16	4.36	37.52	116	248	Peak
2412	97.13	103.04			27.23	4.38	37.52	116	248	Average
2412	105.1	111.01			27.23	4.38	37.52	116	248	Peak
4824	42.34	57.25	54	-11.66	31.17	6.81	52.89	111	152	Average
4824	47.32	62.23	74	-26.68	31.17	6.81	52.89	111	152	Peak
Antenna Polarity & Test Distance: Vertical at 3 m										
Frequency (MHz)	Emission Level (dBuV/m)	Read Level (dBuV)	Limit (dBuV/m)	Margin (dB)	Antenna Factor (dB/m)	Cable Loss (dB)	Preamp Factor (dB)	Antenna Height (cm)	Table Angle (Degree)	Remark
2389.94	52.36	58.36	54	-1.64	27.16	4.36	37.52	166	30	Average
2389.94	62.98	68.98	74	-11.02	27.16	4.36	37.52	166	30	Peak
2412	106.86	112.77			27.23	4.38	37.52	166	30	Average
2412	115.63	121.54			27.23	4.38	37.52	166	30	Peak
4824	43.45	58.36	54	-10.55	31.17	6.81	52.89	201	256	Average
4824	48.73	63.64	74	-25.27	31.17	6.81	52.89	201	256	Peak

Remarks:

- Emission Level = Read Level + Antenna Factor + Cable Loss - Preamp Factor
Margin Value = Emission Level – Limit value
- 2412 MHz: Fundamental Frequency.
- The other emission levels were very low against the limit.

EUT Test Condition		Measurement Detail	
Channel	Channel 6	Frequency Range	1 GHz ~ 25 GHz
Input Power	120 Vac, 60 Hz	Detector Function	Peak (PK) Average (AV)
Environmental Conditions	25 deg. C, 65 % RH	Tested By	Jisyong Wang

Antenna Polarity & Test Distance: Horizontal at 3 m										
Frequency (MHz)	Emission Level (dBuV/m)	Read Level (dBuV)	Limit (dBuV/m)	Margin (dB)	Antenna Factor (dB/m)	Cable Loss (dB)	Preamp Factor (dB)	Antenna Height (cm)	Table Angle (Degree)	Remark
2362.22	36.76	42.91	54	-17.24	27.01	4.33	37.49	119	249	Average
2362.22	48.45	54.6	74	-25.55	27.01	4.33	37.49	119	249	Peak
2437	98.3	103.98			27.38	4.4	37.46	119	249	Average
2437	106.41	112.09			27.38	4.4	37.46	119	249	Peak
2484.16	36.46	41.82	54	-17.54	27.53	4.43	37.32	119	249	Average
2484.16	49.03	54.39	74	-24.97	27.53	4.43	37.32	119	249	Peak
4874	40.94	55.69	54	-13.06	31.25	6.86	52.86	152	111	Average
4874	46.04	60.79	74	-27.96	31.25	6.86	52.86	152	111	Peak

Antenna Polarity & Test Distance: Vertical at 3 m										
Frequency (MHz)	Emission Level (dBuV/m)	Read Level (dBuV)	Limit (dBuV/m)	Margin (dB)	Antenna Factor (dB/m)	Cable Loss (dB)	Preamp Factor (dB)	Antenna Height (cm)	Table Angle (Degree)	Remark
2362.22	41.16	47.31	54	-12.84	27.01	4.33	37.49	120	60	Average
2362.22	52.54	58.69	74	-21.46	27.01	4.33	37.49	120	60	Peak
2437	109.63	115.31			27.38	4.4	37.46	120	60	Average
2437	117.45	123.13			27.38	4.4	37.46	120	60	Peak
2483.72	43.35	48.71	54	-10.65	27.53	4.43	37.32	120	60	Average
2483.72	55.72	61.08	74	-18.28	27.53	4.43	37.32	120	60	Peak
4874	43.87	58.62	54	-10.13	31.25	6.86	52.86	147	152	Average
4874	48.83	63.58	74	-25.17	31.25	6.86	52.86	147	152	Peak

Remarks:

- Emission Level = Read Level + Antenna Factor + Cable Loss - Preamp Factor
Margin Value = Emission Level – Limit value
- 2437 MHz: Fundamental Frequency.
- The other emission levels were very low against the limit.

EUT Test Condition		Measurement Detail	
Channel	Channel 11	Frequency Range	1 GHz ~ 25 GHz
Input Power	120 Vac, 60 Hz	Detector Function	Peak (PK) Average (AV)
Environmental Conditions	25 deg. C, 65 % RH	Tested By	Jisyong Wang

Antenna Polarity & Test Distance: Horizontal at 3 m										
Frequency (MHz)	Emission Level (dBUV/m)	Read Level (dBUV)	Limit (dBUV/m)	Margin (dB)	Antenna Factor (dB/m)	Cable Loss (dB)	Preamp Factor (dB)	Antenna Height (cm)	Table Angle (Degree)	Remark
2462	95.45	100.97			27.46	4.41	37.39	116	252	Average
2462	103.83	109.35			27.46	4.41	37.39	116	252	Peak
2483.52	43.36	48.72	54	-10.64	27.53	4.43	37.32	116	252	Average
2483.52	55.15	60.51	74	-18.85	27.53	4.43	37.32	116	252	Peak
4924	41.3	55.96	54	-12.7	31.34	6.89	52.89	185	265	Average
4924	46.3	60.96	74	-27.7	31.34	6.89	52.89	185	265	Peak
Antenna Polarity & Test Distance: Vertical at 3 m										
Frequency (MHz)	Emission Level (dBUV/m)	Read Level (dBUV)	Limit (dBUV/m)	Margin (dB)	Antenna Factor (dB/m)	Cable Loss (dB)	Preamp Factor (dB)	Antenna Height (cm)	Table Angle (Degree)	Remark
2462	107.33	112.85			27.46	4.41	37.39	119	61	Average
2462	114.97	120.49			27.46	4.41	37.39	119	61	Peak
2483.52	52.25	57.61	54	-1.75	27.53	4.43	37.32	119	61	Average
2483.52	65.04	70.4	74	-8.96	27.53	4.43	37.32	119	61	Peak
4924	42.86	57.52	54	-11.14	31.34	6.89	52.89	111	174	Average
4924	48.05	62.71	74	-25.95	31.34	6.89	52.89	111	174	Peak

Remarks:

- Emission Level = Read Level + Antenna Factor + Cable Loss - Preamp Factor
Margin Value = Emission Level – Limit value
- 2462 MHz: Fundamental Frequency.
- The other emission levels were very low against the limit.

802.11g

EUT Test Condition		Measurement Detail	
Channel	Channel 1	Frequency Range	1 GHz ~ 25 GHz
Input Power	120 Vac, 60 Hz	Detector Function	Peak (PK) Average (AV)
Environmental Conditions	25 deg. C, 65 % RH	Tested By	Jisyong Wang

Antenna Polarity & Test Distance: Horizontal at 3 m										
Frequency (MHz)	Emission Level (dBuV/m)	Read Level (dBuV)	Limit (dBuV/m)	Margin (dB)	Antenna Factor (dB/m)	Cable Loss (dB)	Preamp Factor (dB)	Antenna Height (cm)	Table Angle (Degree)	Remark
2389.94	44.17	50.17	54	-9.83	27.16	4.36	37.52	114	247	Average
2389.94	63.42	69.42	74	-10.58	27.16	4.36	37.52	114	247	Peak
2412	94.46	100.37			27.23	4.38	37.52	114	247	Average
2412	102.14	108.05			27.23	4.38	37.52	114	247	Peak
4824	39.34	54.25	54	-14.66	31.17	6.81	52.89	152	111	Average
4824	44.26	59.17	74	-29.74	31.17	6.81	52.89	152	111	Peak

Antenna Polarity & Test Distance: Vertical at 3 m										
Frequency (MHz)	Emission Level (dBuV/m)	Read Level (dBuV)	Limit (dBuV/m)	Margin (dB)	Antenna Factor (dB/m)	Cable Loss (dB)	Preamp Factor (dB)	Antenna Height (cm)	Table Angle (Degree)	Remark
2389.94	52.21	58.21	54	-1.79	27.16	4.36	37.52	122	165	Average
2389.94	71.93	77.93	74	-2.07	27.16	4.36	37.52	122	165	Peak
2412	103.3	109.21			27.23	4.38	37.52	122	165	Average
2412	110.74	116.65			27.23	4.38	37.52	122	165	Peak
4824	39.28	54.19	54	-14.72	31.17	6.81	52.89	236	211	Average
4824	44.39	59.3	74	-29.61	31.17	6.81	52.89	236	211	Peak

Remarks:

1. Emission Level = Read Level + Antenna Factor + Cable Loss - Preamp Factor
Margin Value = Emission Level – Limit value
2. 2412 MHz: Fundamental Frequency.
3. The other emission levels were very low against the limit.

EUT Test Condition		Measurement Detail	
Channel	Channel 6	Frequency Range	1 GHz ~ 25 GHz
Input Power	120 Vac, 60 Hz	Detector Function	Peak (PK) Average (AV)
Environmental Conditions	25 deg. C, 65 % RH	Tested By	Jisyong Wang

Antenna Polarity & Test Distance: Horizontal at 3 m										
Frequency (MHz)	Emission Level (dBuV/m)	Read Level (dBuV)	Limit (dBuV/m)	Margin (dB)	Antenna Factor (dB/m)	Cable Loss (dB)	Preamp Factor (dB)	Antenna Height (cm)	Table Angle (Degree)	Remark
2389.94	39.81	45.81	54	-14.19	27.16	4.36	37.52	119	250	Average
2389.94	54.06	60.06	74	-19.94	27.16	4.36	37.52	119	250	Peak
2437	96.31	101.99			27.38	4.4	37.46	119	250	Average
2437	104.41	110.09			27.38	4.4	37.46	119	250	Peak
2483.56	42.63	47.99	54	-11.37	27.53	4.43	37.32	119	250	Average
2483.56	55.62	60.98	74	-18.38	27.53	4.43	37.32	119	250	Peak
4874	39.51	54.26	54	-14.49	31.25	6.86	52.86	152	111	Average
4874	45.06	59.81	74	-28.94	31.25	6.86	52.86	152	111	Peak
Antenna Polarity & Test Distance: Vertical at 3 m										
Frequency (MHz)	Emission Level (dBuV/m)	Read Level (dBuV)	Limit (dBuV/m)	Margin (dB)	Antenna Factor (dB/m)	Cable Loss (dB)	Preamp Factor (dB)	Antenna Height (cm)	Table Angle (Degree)	Remark
2389.94	47.86	53.86	54	-6.14	27.16	4.36	37.52	123	164	Average
2389.94	62.85	68.85	74	-11.15	27.16	4.36	37.52	123	164	Peak
2437	106.34	112.02			27.38	4.4	37.46	123	164	Average
2437	114.17	119.85			27.38	4.4	37.46	123	164	Peak
2483.56	52.2	57.56	54	-1.8	27.53	4.43	37.32	123	164	Average
2483.56	66.08	71.44	74	-7.92	27.53	4.43	37.32	123	164	Peak
4874	40.9	55.65	54	-13.1	31.25	6.86	52.86	102	236	Average
4874	45.94	60.69	74	-28.06	31.25	6.86	52.86	102	236	Peak

Remarks:

- Emission Level = Read Level + Antenna Factor + Cable Loss - Preamp Factor
Margin Value = Emission Level – Limit value
- 2437 MHz: Fundamental Frequency.
- The other emission levels were very low against the limit.

EUT Test Condition		Measurement Detail	
Channel	Channel 11	Frequency Range	1 GHz ~ 25 GHz
Input Power	120 Vac, 60 Hz	Detector Function	Peak (PK) Average (AV)
Environmental Conditions	25 deg. C, 65 % RH	Tested By	Jisyong Wang

Antenna Polarity & Test Distance: Horizontal at 3 m										
Frequency (MHz)	Emission Level (dBuV/m)	Read Level (dBuV)	Limit (dBuV/m)	Margin (dB)	Antenna Factor (dB/m)	Cable Loss (dB)	Preamp Factor (dB)	Antenna Height (cm)	Table Angle (Degree)	Remark
2462	92.01	97.53			27.46	4.41	37.39	112	252	Average
2462	100.53	106.05			27.46	4.41	37.39	112	252	Peak
2483.56	43.69	49.05	54	-10.31	27.53	4.43	37.32	112	252	Average
2483.56	63.79	69.15	74	-10.21	27.53	4.43	37.32	112	252	Peak
4924	40.35	55.01	54	-13.65	31.34	6.89	52.89	132	214	Average
4924	45.41	60.07	74	-28.59	31.34	6.89	52.89	132	214	Peak
Antenna Polarity & Test Distance: Vertical at 3 m										
Frequency (MHz)	Emission Level (dBuV/m)	Read Level (dBuV)	Limit (dBuV/m)	Margin (dB)	Antenna Factor (dB/m)	Cable Loss (dB)	Preamp Factor (dB)	Antenna Height (cm)	Table Angle (Degree)	Remark
2462	102.66	108.18			27.46	4.41	37.39	108	125	Average
2462	110.67	116.19			27.46	4.41	37.39	108	125	Peak
2483.5	52.2	73.69	54	-1.8	27.53	4.94	53.96	108	125	Average
2483.5	71.8	77.16	74	-2.2	27.53	4.43	37.32	108	125	Peak
4924	39.97	54.63	54	-14.03	31.34	6.89	52.89	231	111	Average
4924	45.27	59.93	74	-28.73	31.34	6.89	52.89	231	111	Peak

Remarks:

- Emission Level = Read Level + Antenna Factor + Cable Loss - Preamp Factor
Margin Value = Emission Level – Limit value
- 2462 MHz: Fundamental Frequency.
- The other emission levels were very low against the limit.

802.11n (HT20)

EUT Test Condition		Measurement Detail	
Channel	Channel 1	Frequency Range	1 GHz ~ 25 GHz
Input Power	120 Vac, 60 Hz	Detector Function	Peak (PK) Average (AV)
Environmental Conditions	25 deg. C, 65 % RH	Tested By	Jisyong Wang

Antenna Polarity & Test Distance: Horizontal at 3 m

Frequency (MHz)	Emission Level (dBuV/m)	Read Level (dBuV)	Limit (dBuV/m)	Margin (dB)	Antenna Factor (dB/m)	Cable Loss (dB)	Preamp Factor (dB)	Antenna Height (cm)	Table Angle (Degree)	Remark
2389.94	43.13	49.13	54	-10.87	27.16	4.36	37.52	120	247	Average
2389.94	62.73	68.73	74	-11.27	27.16	4.36	37.52	120	247	Peak
2412	92.86	98.77			27.23	4.38	37.52	120	247	Average
2412	101.61	107.52			27.23	4.38	37.52	120	247	Peak
4824	40.49	55.4	54	-13.51	31.17	6.81	52.89	185	265	Average
4824	45.51	60.42	74	-28.49	31.17	6.81	52.89	185	265	Peak

Antenna Polarity & Test Distance: Vertical at 3 m

Frequency (MHz)	Emission Level (dBuV/m)	Read Level (dBuV)	Limit (dBuV/m)	Margin (dB)	Antenna Factor (dB/m)	Cable Loss (dB)	Preamp Factor (dB)	Antenna Height (cm)	Table Angle (Degree)	Remark
2390	52.22	74.1	54	-1.78	27.16	4.85	53.89	181	199	Average
2390	71.87	77.87	74	-2.13	27.16	4.36	37.52	181	199	Peak
2412	101.82	107.73			27.23	4.38	37.52	181	199	Average
2412	110.59	116.5			27.23	4.38	37.52	181	199	Peak
4824	39.61	54.52	54	-14.39	31.17	6.81	52.89	285	214	Average
4824	44.98	59.89	74	-29.02	31.17	6.81	52.89	285	214	Peak

Remarks:

- Emission Level = Read Level + Antenna Factor + Cable Loss - Preamp Factor
Margin Value = Emission Level – Limit value
- 2412 MHz: Fundamental Frequency.
- The other emission levels were very low against the limit.

EUT Test Condition		Measurement Detail	
Channel	Channel 6	Frequency Range	1 GHz ~ 25 GHz
Input Power	120 Vac, 60 Hz	Detector Function	Peak (PK) Average (AV)
Environmental Conditions	25 deg. C, 65 % RH	Tested By	Jisyong Wang

Antenna Polarity & Test Distance: Horizontal at 3 m										
Frequency (MHz)	Emission Level (dBuV/m)	Read Level (dBuV)	Limit (dBuV/m)	Margin (dB)	Antenna Factor (dB/m)	Cable Loss (dB)	Preamp Factor (dB)	Antenna Height (cm)	Table Angle (Degree)	Remark
2389.94	39.38	45.38	54	-14.62	27.16	4.36	37.52	121	248	Average
2389.94	58.29	64.29	74	-15.71	27.16	4.36	37.52	121	248	Peak
2437	95.58	101.26			27.38	4.4	37.46	121	248	Average
2437	103.65	109.33			27.38	4.4	37.46	121	248	Peak
2483.6	39.5	44.86	54	-14.5	27.53	4.43	37.32	121	248	Average
2483.6	54.66	60.02	74	-19.34	27.53	4.43	37.32	121	248	Peak
4874	39.5	54.25	54	-14.5	31.25	6.86	52.86	152	111	Average
4874	44.99	59.74	74	-29.01	31.25	6.86	52.86	152	111	Peak

Antenna Polarity & Test Distance: Vertical at 3 m										
Frequency (MHz)	Emission Level (dBuV/m)	Read Level (dBuV)	Limit (dBuV/m)	Margin (dB)	Antenna Factor (dB/m)	Cable Loss (dB)	Preamp Factor (dB)	Antenna Height (cm)	Table Angle (Degree)	Remark
2389.94	47.27	53.27	54	-6.73	27.16	4.36	37.52	162	198	Average
2389.94	65.95	71.95	74	-8.05	27.16	4.36	37.52	162	198	Peak
2437	106.8	112.48			27.38	4.4	37.46	162	198	Average
2437	114.79	120.47			27.38	4.4	37.46	162	198	Peak
2483.52	50.02	55.38	54	-3.98	27.53	4.43	37.32	162	198	Average
2483.52	68.27	73.63	74	-5.73	27.53	4.43	37.32	162	198	Peak
4874	41.1	55.85	54	-12.9	31.25	6.86	52.86	201	256	Average
4874	46.12	60.87	74	-27.88	31.25	6.86	52.86	201	256	Peak

Remarks:

- Emission Level = Read Level + Antenna Factor + Cable Loss - Preamp Factor
Margin Value = Emission Level – Limit value
- 2437 MHz: Fundamental Frequency.
- The other emission levels were very low against the limit.

EUT Test Condition		Measurement Detail	
Channel	Channel 11	Frequency Range	1 GHz ~ 25 GHz
Input Power	120 Vac, 60 Hz	Detector Function	Peak (PK) Average (AV)
Environmental Conditions	25 deg. C, 65 % RH	Tested By	Jisyong Wang

Antenna Polarity & Test Distance: Horizontal at 3 m										
Frequency (MHz)	Emission Level (dBuV/m)	Read Level (dBuV)	Limit (dBuV/m)	Margin (dB)	Antenna Factor (dB/m)	Cable Loss (dB)	Preamp Factor (dB)	Antenna Height (cm)	Table Angle (Degree)	Remark
2462	92.62	98.14			27.46	4.41	37.39	115	252	Average
2462	100.68	106.2			27.46	4.41	37.39	115	252	Peak
2483.6	42.49	47.85	54	-11.51	27.53	4.43	37.32	115	252	Average
2483.6	63.64	69	74	-10.36	27.53	4.43	37.32	115	252	Peak
4924	39.86	54.52	54	-14.14	31.34	6.89	52.89	185	241	Average
4924	45.33	59.99	74	-28.67	31.34	6.89	52.89	185	241	Peak
Antenna Polarity & Test Distance: Vertical at 3 m										
Frequency (MHz)	Emission Level (dBuV/m)	Read Level (dBuV)	Limit (dBuV/m)	Margin (dB)	Antenna Factor (dB/m)	Cable Loss (dB)	Preamp Factor (dB)	Antenna Height (cm)	Table Angle (Degree)	Remark
2462	102.13	107.65			27.46	4.41	37.39	145	198	Average
2462	110.34	115.86			27.46	4.41	37.39	145	198	Peak
2483.5	52.9	74.39	54	-1.1	27.53	4.94	53.96	145	198	Average
2483.5	72.73	78.09	74	-1.27	27.53	4.43	37.32	145	198	Peak
4924	31.24	45.9	54	-22.76	31.34	6.89	52.89	196	236	Average
4924	45.34	60	74	-28.66	31.34	6.89	52.89	196	236	Peak

Remarks:

- Emission Level = Read Level + Antenna Factor + Cable Loss - Preamp Factor
Margin Value = Emission Level – Limit value
- 2462 MHz: Fundamental Frequency.
- The other emission levels were very low against the limit.

Mode B
802.11b

EUT Test Condition		Measurement Detail	
Channel	Channel 1	Frequency Range	1 GHz ~ 25 GHz
Input Power	120 Vac, 60 Hz	Detector Function	Peak (PK) Average (AV)
Environmental Conditions	25 deg. C, 65 % RH	Tested By	Jisyong Wang

Antenna Polarity & Test Distance: Horizontal at 3 m										
Frequency (MHz)	Emission Level (dBuV/m)	Read Level (dBuV)	Limit (dBuV/m)	Margin (dB)	Antenna Factor (dB/m)	Cable Loss (dB)	Preamp Factor (dB)	Antenna Height (cm)	Table Angle (Degree)	Remark
2389.94	50.5	56.5	54	-3.5	27.16	4.36	37.52	102	224	Average
2389.94	59.21	65.21	74	-14.79	27.16	4.36	37.52	102	224	Peak
2412	105.02	110.93			27.23	4.38	37.52	102	224	Average
2412	110.22	116.13			27.23	4.38	37.52	102	224	Peak
4824	40.72	55.63	54	-13.28	31.17	6.81	52.89	203	213	Average
4824	45.83	60.74	74	-28.17	31.17	6.81	52.89	203	213	Peak

Antenna Polarity & Test Distance: Vertical at 3 m										
Frequency (MHz)	Emission Level (dBuV/m)	Read Level (dBuV)	Limit (dBuV/m)	Margin (dB)	Antenna Factor (dB/m)	Cable Loss (dB)	Preamp Factor (dB)	Antenna Height (cm)	Table Angle (Degree)	Remark
2389.94	49.89	55.89	54	-4.11	27.16	4.36	37.52	100	267	Average
2389.94	58.18	64.18	74	-15.82	27.16	4.36	37.52	100	267	Peak
2412	104.86	110.77			27.23	4.38	37.52	100	267	Average
2412	109.41	115.32			27.23	4.38	37.52	100	267	Peak
4824	42.72	57.63	54	-11.28	31.17	6.81	52.89	152	213	Average
4824	47.5	62.41	74	-26.5	31.17	6.81	52.89	152	213	Peak

Remarks:

- Emission Level = Read Level + Antenna Factor + Cable Loss - Preamp Factor
Margin Value = Emission Level – Limit value
- 2412 MHz: Fundamental Frequency.
- The other emission levels were very low against the limit.

EUT Test Condition		Measurement Detail	
Channel	Channel 6	Frequency Range	1 GHz ~ 25 GHz
Input Power	120 Vac, 60 Hz	Detector Function	Peak (PK) Average (AV)
Environmental Conditions	25 deg. C, 65 % RH	Tested By	Jisyong Wang

Antenna Polarity & Test Distance: Horizontal at 3 m										
Frequency (MHz)	Emission Level (dBuV/m)	Read Level (dBuV)	Limit (dBuV/m)	Margin (dB)	Antenna Factor (dB/m)	Cable Loss (dB)	Preamp Factor (dB)	Antenna Height (cm)	Table Angle (Degree)	Remark
2385.04	39.48	45.63	54	-14.52	27.01	4.33	37.49	100	225	Average
2385.04	51.44	57.51	74	-22.56	27.08	4.35	37.5	100	225	Peak
2437	108.28	113.96			27.38	4.4	37.46	100	225	Average
2437	112.9	118.58			27.38	4.4	37.46	100	225	Peak
2484.08	40.18	45.54	54	-13.82	27.53	4.43	37.32	100	225	Average
2484.08	53.23	58.59	74	-20.77	27.53	4.43	37.32	100	225	Peak
4874	38.27	53.02	54	-15.73	31.25	6.86	52.86	251	123	Average
4874	44.19	58.94	74	-29.81	31.25	6.86	52.86	251	123	Peak

Antenna Polarity & Test Distance: Vertical at 3 m										
Frequency (MHz)	Emission Level (dBuV/m)	Read Level (dBuV)	Limit (dBuV/m)	Margin (dB)	Antenna Factor (dB/m)	Cable Loss (dB)	Preamp Factor (dB)	Antenna Height (cm)	Table Angle (Degree)	Remark
2361.1	39.97	46.12	54	-14.03	27.01	4.33	37.49	139	266	Average
2361.1	51.05	57.2	74	-22.95	27.01	4.33	37.49	139	266	Peak
2437	106.38	112.06			27.38	4.4	37.46	139	266	Average
2437	110.89	116.57			27.38	4.4	37.46	139	266	Peak
2488.12	38.84	44.2	54	-15.16	27.53	4.43	37.32	139	266	Average
2488.12	51.82	57.1	74	-22.18	27.61	4.43	37.32	139	266	Peak
4874	38.27	53.02	54	-15.73	31.25	6.86	52.86	222	256	Average
4874	44.04	58.79	74	-29.96	31.25	6.86	52.86	222	256	Peak

Remarks:

- Emission Level = Read Level + Antenna Factor + Cable Loss - Preamp Factor
Margin Value = Emission Level – Limit value
- 2437 MHz: Fundamental Frequency.
- The other emission levels were very low against the limit.

EUT Test Condition		Measurement Detail	
Channel	Channel 11	Frequency Range	1 GHz ~ 25 GHz
Input Power	120 Vac, 60 Hz	Detector Function	Peak (PK) Average (AV)
Environmental Conditions	25 deg. C, 65 % RH	Tested By	Jisyong Wang

Antenna Polarity & Test Distance: Horizontal at 3 m										
Frequency (MHz)	Emission Level (dBuV/m)	Read Level (dBuV)	Limit (dBuV/m)	Margin (dB)	Antenna Factor (dB/m)	Cable Loss (dB)	Preamp Factor (dB)	Antenna Height (cm)	Table Angle (Degree)	Remark
2462	105.27	110.79			27.46	4.41	37.39	102	225	Average
2462	109.72	115.24			27.46	4.41	37.39	102	225	Peak
2483.52	51.8	57.16	54	-2.2	27.53	4.43	37.32	102	225	Average
2483.52	58.25	63.61	74	-15.75	27.53	4.43	37.32	102	225	Peak
4924	38.59	53.25	54	-15.41	31.34	6.89	52.89	256	214	Average
4924	44.13	58.79	74	-29.87	31.34	6.89	52.89	256	214	Peak

Antenna Polarity & Test Distance: Vertical at 3 m										
Frequency (MHz)	Emission Level (dBuV/m)	Read Level (dBuV)	Limit (dBuV/m)	Margin (dB)	Antenna Factor (dB/m)	Cable Loss (dB)	Preamp Factor (dB)	Antenna Height (cm)	Table Angle (Degree)	Remark
2462	102.81	108.33			27.46	4.41	37.39	100	263	Average
2462	107.4	112.92			27.46	4.41	37.39	100	263	Peak
2483.52	50.02	55.38	54	-3.98	27.53	4.43	37.32	100	263	Average
2483.52	56.89	62.25	74	-17.11	27.53	4.43	37.32	100	263	Peak
4924	38.03	52.69	54	-15.97	31.34	6.89	52.89	203	256	Average
4924	42.97	57.63	74	-31.03	31.34	6.89	52.89	203	256	Peak

Remarks:

- Emission Level = Read Level + Antenna Factor + Cable Loss - Preamp Factor
Margin Value = Emission Level – Limit value
- 2462 MHz: Fundamental Frequency.
- The other emission levels were very low against the limit.

802.11g

EUT Test Condition		Measurement Detail	
Channel	Channel 1	Frequency Range	1 GHz ~ 25 GHz
Input Power	120 Vac, 60 Hz	Detector Function	Peak (PK) Average (AV)
Environmental Conditions	25 deg. C, 65 % RH	Tested By	Jisyong Wang

Antenna Polarity & Test Distance: Horizontal at 3 m

Frequency (MHz)	Emission Level (dBuV/m)	Read Level (dBuV)	Limit (dBuV/m)	Margin (dB)	Antenna Factor (dB/m)	Cable Loss (dB)	Preamp Factor (dB)	Antenna Height (cm)	Table Angle (Degree)	Remark
2389.94	51.6	57.6	54	-2.4	27.16	4.36	37.52	101	224	Average
2389.94	70.97	76.97	74	-3.03	27.16	4.36	37.52	101	224	Peak
2412	102.22	108.13			27.23	4.38	37.52	101	224	Average
2412	111.6	117.51			27.23	4.38	37.52	101	224	Peak
4824	39.61	54.52	54	-14.39	31.17	6.81	52.89	256	231	Average
4824	44.2	59.11	74	-29.8	31.17	6.81	52.89	256	231	Peak

Antenna Polarity & Test Distance: Vertical at 3 m

Frequency (MHz)	Emission Level (dBuV/m)	Read Level (dBuV)	Limit (dBuV/m)	Margin (dB)	Antenna Factor (dB/m)	Cable Loss (dB)	Preamp Factor (dB)	Antenna Height (cm)	Table Angle (Degree)	Remark
2389.94	51.21	57.21	54	-2.79	27.16	4.36	37.52	100	266	Average
2389.94	70.84	76.84	74	-3.16	27.16	4.36	37.52	100	266	Peak
2412	101.81	107.72			27.23	4.38	37.52	100	266	Average
2412	111.22	117.13			27.23	4.38	37.52	100	266	Peak
4824	37.78	52.69	54	-16.22	31.17	6.81	52.89	203	111	Average
4824	42.36	57.27	74	-31.64	31.17	6.81	52.89	203	111	Peak

Remarks:

1. Emission Level = Read Level + Antenna Factor + Cable Loss - Preamp Factor
Margin Value = Emission Level – Limit value
2. 2412 MHz: Fundamental Frequency.
3. The other emission levels were very low against the limit.

EUT Test Condition		Measurement Detail	
Channel	Channel 6	Frequency Range	1 GHz ~ 25 GHz
Input Power	120 Vac, 60 Hz	Detector Function	Peak (PK) Average (AV)
Environmental Conditions	25 deg. C, 65 % RH	Tested By	Jisyong Wang

Antenna Polarity & Test Distance: Horizontal at 3 m										
Frequency (MHz)	Emission Level (dBuV/m)	Read Level (dBuV)	Limit (dBuV/m)	Margin (dB)	Antenna Factor (dB/m)	Cable Loss (dB)	Preamp Factor (dB)	Antenna Height (cm)	Table Angle (Degree)	Remark
2389.8	45.51	51.51	54	-8.49	27.16	4.36	37.52	101	226	Average
2389.8	59.81	65.79	74	-14.19	27.16	4.36	37.5	101	226	Peak
2437	105.18	110.86			27.38	4.4	37.46	101	226	Average
2437	114.51	120.19			27.38	4.4	37.46	101	226	Peak
2484.24	47.73	53.09	54	-6.27	27.53	4.43	37.32	101	226	Average
2484.24	62.14	67.5	74	-11.86	27.53	4.43	37.32	101	226	Peak
4874	38.57	53.32	54	-15.43	31.25	6.86	52.86	251	123	Average
4874	43.56	58.31	74	-30.44	31.25	6.86	52.86	251	123	Peak

Antenna Polarity & Test Distance: Vertical at 3 m										
Frequency (MHz)	Emission Level (dBuV/m)	Read Level (dBuV)	Limit (dBuV/m)	Margin (dB)	Antenna Factor (dB/m)	Cable Loss (dB)	Preamp Factor (dB)	Antenna Height (cm)	Table Angle (Degree)	Remark
2389.8	43.93	49.93	54	-10.07	27.16	4.36	37.52	110	263	Average
2389.8	58.95	64.93	74	-15.05	27.16	4.36	37.5	110	263	Peak
2437	103.1	108.78			27.38	4.4	37.46	110	263	Average
2437	112.83	118.51			27.38	4.4	37.46	110	263	Peak
2483.92	46.51	51.87	54	-7.49	27.53	4.43	37.32	110	263	Average
2483.92	60.52	65.88	74	-13.48	27.53	4.43	37.32	110	263	Peak
4874	40.5	55.25	54	-13.5	31.25	6.86	52.86	252	236	Average
4874	42.42	57.17	74	-31.58	31.25	6.86	52.86	252	236	Peak

Remarks:

- Emission Level = Read Level + Antenna Factor + Cable Loss - Preamp Factor
Margin Value = Emission Level – Limit value
- 2437 MHz: Fundamental Frequency.
- The other emission levels were very low against the limit.

EUT Test Condition		Measurement Detail	
Channel	Channel 11	Frequency Range	1 GHz ~ 25 GHz
Input Power	120 Vac, 60 Hz	Detector Function	Peak (PK) Average (AV)
Environmental Conditions	25 deg. C, 65 % RH	Tested By	Jisyong Wang

Antenna Polarity & Test Distance: Horizontal at 3 m										
Frequency (MHz)	Emission Level (dBuV/m)	Read Level (dBuV)	Limit (dBuV/m)	Margin (dB)	Antenna Factor (dB/m)	Cable Loss (dB)	Preamp Factor (dB)	Antenna Height (cm)	Table Angle (Degree)	Remark
2462	102.47	107.99			27.46	4.41	37.39	101	225	Average
2462	112.4	117.92			27.46	4.41	37.39	101	225	Peak
2483.6	52.88	58.24	54	-1.12	27.53	4.43	37.32	101	225	Average
2483.6	71.08	76.44	74	-2.92	27.53	4.43	37.32	101	225	Peak
4924	38.59	53.25	54	-15.41	31.34	6.89	52.89	251	111	Average
4924	44.03	58.69	74	-29.97	31.34	6.89	52.89	251	111	Peak
Antenna Polarity & Test Distance: Vertical at 3 m										
Frequency (MHz)	Emission Level (dBuV/m)	Read Level (dBuV)	Limit (dBuV/m)	Margin (dB)	Antenna Factor (dB/m)	Cable Loss (dB)	Preamp Factor (dB)	Antenna Height (cm)	Table Angle (Degree)	Remark
2462	102.67	108.19			27.46	4.41	37.39	125	23	Average
2462	112.29	117.81			27.46	4.41	37.39	125	23	Peak
2483.52	53.44	58.8	54	-0.56	27.53	4.43	37.32	125	23	Average
2483.52	71.57	76.93	74	-2.43	27.53	4.43	37.32	125	23	Peak
4924	40.81	55.47	54	-13.19	31.34	6.89	52.89	203	256	Average
4924	45.83	60.49	74	-28.17	31.34	6.89	52.89	203	256	Peak

Remarks:

- Emission Level = Read Level + Antenna Factor + Cable Loss - Preamp Factor
Margin Value = Emission Level – Limit value
- 2462 MHz: Fundamental Frequency.
- The other emission levels were very low against the limit.

802.11n (HT20)

EUT Test Condition		Measurement Detail	
Channel	Channel 1	Frequency Range	1 GHz ~ 25 GHz
Input Power	120 Vac, 60 Hz	Detector Function	Peak (PK) Average (AV)
Environmental Conditions	25 deg. C, 65 % RH	Tested By	Jisyong Wang

Antenna Polarity & Test Distance: Horizontal at 3 m

Frequency (MHz)	Emission Level (dBuV/m)	Read Level (dBuV)	Limit (dBuV/m)	Margin (dB)	Antenna Factor (dB/m)	Cable Loss (dB)	Preamp Factor (dB)	Antenna Height (cm)	Table Angle (Degree)	Remark
2389.94	52.55	58.55	54	-1.45	27.16	4.36	37.52	101	224	Average
2389.94	69.35	75.33	74	-4.65	27.16	4.36	37.5	101	224	Peak
2412	102.33	108.24			27.23	4.38	37.52	101	224	Average
2412	111.81	117.72			27.23	4.38	37.52	101	224	Peak
4824	37.45	52.36	54	-16.55	31.17	6.81	52.89	100	26	Average
4824	42.51	57.42	74	-31.49	31.17	6.81	52.89	100	26	Peak

Antenna Polarity & Test Distance: Vertical at 3 m

Frequency (MHz)	Emission Level (dBuV/m)	Read Level (dBuV)	Limit (dBuV/m)	Margin (dB)	Antenna Factor (dB/m)	Cable Loss (dB)	Preamp Factor (dB)	Antenna Height (cm)	Table Angle (Degree)	Remark
2389.94	52.52	58.52	54	-1.48	27.16	4.36	37.52	100	267	Average
2389.94	71.54	77.52	74	-2.46	27.16	4.36	37.5	100	267	Peak
2412	102.11	108.02			27.23	4.38	37.52	100	267	Average
2412	111.61	117.52			27.23	4.38	37.52	100	267	Peak
4824	40.11	55.02	54	-13.89	31.17	6.81	52.89	111	165	Average
4824	45.2	60.11	74	-28.8	31.17	6.81	52.89	111	165	Peak

Remarks:

- Emission Level = Read Level + Antenna Factor + Cable Loss - Preamp Factor
Margin Value = Emission Level – Limit value
- 2412 MHz: Fundamental Frequency.
- The other emission levels were very low against the limit.

EUT Test Condition		Measurement Detail	
Channel	Channel 6	Frequency Range	1 GHz ~ 25 GHz
Input Power	120 Vac, 60 Hz	Detector Function	Peak (PK) Average (AV)
Environmental Conditions	25 deg. C, 65 % RH	Tested By	Jisyong Wang

Antenna Polarity & Test Distance: Horizontal at 3 m										
Frequency (MHz)	Emission Level (dBuV/m)	Read Level (dBuV)	Limit (dBuV/m)	Margin (dB)	Antenna Factor (dB/m)	Cable Loss (dB)	Preamp Factor (dB)	Antenna Height (cm)	Table Angle (Degree)	Remark
2389.94	44.51	50.51	54	-9.49	27.16	4.36	37.52	100	225	Average
2389.94	61.77	67.75	74	-12.23	27.16	4.36	37.5	100	225	Peak
2437	104.63	110.31			27.38	4.4	37.46	100	225	Average
2437	113.58	119.26			27.38	4.4	37.46	100	225	Peak
2484.28	45.9	51.26	54	-8.1	27.53	4.43	37.32	100	225	Average
2484.28	63.99	69.35	74	-10.01	27.53	4.43	37.32	100	225	Peak
4874	37.94	52.69	54	-16.06	31.25	6.86	52.86	256	111	Average
4874	43.09	57.84	74	-30.91	31.25	6.86	52.86	256	111	Peak

Antenna Polarity & Test Distance: Vertical at 3 m										
Frequency (MHz)	Emission Level (dBuV/m)	Read Level (dBuV)	Limit (dBuV/m)	Margin (dB)	Antenna Factor (dB/m)	Cable Loss (dB)	Preamp Factor (dB)	Antenna Height (cm)	Table Angle (Degree)	Remark
2389.8	43.17	49.17	54	-10.83	27.16	4.36	37.52	122	26	Average
2389.8	61.94	67.92	74	-12.06	27.16	4.36	37.5	122	26	Peak
2437	105.04	110.72			27.38	4.4	37.46	122	26	Average
2437	115.21	120.89			27.38	4.4	37.46	122	26	Peak
2486.56	47.1	52.46	54	-6.9	27.53	4.43	37.32	122	26	Average
2486.56	63.43	68.79	74	-10.57	27.53	4.43	37.32	122	26	Peak
4874	37.94	52.69	54	-16.06	31.25	6.86	52.86	265	231	Average
4874	42.5	57.25	74	-31.5	31.25	6.86	52.86	265	231	Peak

Remarks:

- Emission Level = Read Level + Antenna Factor + Cable Loss - Preamp Factor
Margin Value = Emission Level – Limit value
- 2437 MHz: Fundamental Frequency.
- The other emission levels were very low against the limit.

EUT Test Condition		Measurement Detail	
Channel	Channel 11	Frequency Range	1 GHz ~ 25 GHz
Input Power	120 Vac, 60 Hz	Detector Function	Peak (PK) Average (AV)
Environmental Conditions	25 deg. C, 65 % RH	Tested By	Jisyong Wang

Antenna Polarity & Test Distance: Horizontal at 3 m										
Frequency (MHz)	Emission Level (dBuV/m)	Read Level (dBuV)	Limit (dBuV/m)	Margin (dB)	Antenna Factor (dB/m)	Cable Loss (dB)	Preamp Factor (dB)	Antenna Height (cm)	Table Angle (Degree)	Remark
2462	102.07	107.59			27.46	4.41	37.39	100	225	Average
2462	111.46	116.98			27.46	4.41	37.39	100	225	Peak
2484.76	52.9	58.26	54	-1.1	27.53	4.43	37.32	100	225	Average
2484.76	70.1	75.46	74	-3.9	27.53	4.43	37.32	100	225	Peak
4924	38.36	53.02	54	-15.64	31.34	6.89	52.89	251	111	Average
4924	44.01	58.67	74	-29.99	31.34	6.89	52.89	251	111	Peak
Antenna Polarity & Test Distance: Vertical at 3 m										
Frequency (MHz)	Emission Level (dBuV/m)	Read Level (dBuV)	Limit (dBuV/m)	Margin (dB)	Antenna Factor (dB/m)	Cable Loss (dB)	Preamp Factor (dB)	Antenna Height (cm)	Table Angle (Degree)	Remark
2462	102.43	107.95			27.46	4.41	37.39	120	24	Average
2462	111.76	117.28			27.46	4.41	37.39	120	24	Peak
2483.56	53.18	58.54	54	-0.82	27.53	4.43	37.32	120	24	Average
2483.56	71.97	77.33	74	-2.03	27.53	4.43	37.32	120	24	Peak
4924	38.59	53.25	54	-15.41	31.34	6.89	52.89	185	265	Average
4924	44.01	58.67	74	-29.99	31.34	6.89	52.89	185	265	Peak

Remarks:

- Emission Level = Read Level + Antenna Factor + Cable Loss - Preamp Factor
Margin Value = Emission Level – Limit value
- 2462 MHz: Fundamental Frequency.
- The other emission levels were very low against the limit.

9 kHz ~ 30 MHz Data:

The amplitude of spurious emissions attenuated more than 20 dB below the permissible value is not required to be report.

30 MHz ~ 1 GHz Worst-Case Data:

Mode A

802.11n (HT20)

EUT Test Condition		Measurement Detail	
Channel	Channel 11	Frequency Range	30 MHz ~ 1 GHz
Input Power	120 Vac, 60 Hz	Detector Function	Peak (PK) Quasi-Peak (QP)
Environmental Conditions	25 deg. C, 65 % RH	Tested By	Jisyong Wang

Antenna Polarity & Test Distance: Horizontal at 3 m										
Frequency (MHz)	Emission Level (dBuV/m)	Read Level (dBuV)	Limit (dBuV/m)	Margin (dB)	Antenna Factor (dB/m)	Cable Loss (dB)	Preamp Factor (dB)	Antenna Height (cm)	Table Angle (Degree)	Remark
44.55	32.82	49.85	40	-7.18	13.6	0.51	31.14	152	213	Peak
145.43	30.41	48.53	43.5	-13.09	12.54	0.96	31.62	165	258	Peak
158.04	33.11	51.2	43.5	-10.39	12.73	1.01	31.83	203	285	Peak
165.8	32.81	51.4	43.5	-10.69	12.15	1.05	31.79	147	195	Peak
657.59	24.17	32.7	46	-21.83	20.3	3.13	31.96	111	132	Peak
915.61	28.14	32.45	46	-17.86	23.6	4.11	32.02	165	295	Peak

Antenna Polarity & Test Distance: Vertical at 3 m										
Frequency (MHz)	Emission Level (dBuV/m)	Read Level (dBuV)	Limit (dBuV/m)	Margin (dB)	Antenna Factor (dB/m)	Cable Loss (dB)	Preamp Factor (dB)	Antenna Height (cm)	Table Angle (Degree)	Remark
60.07	26.98	45.82	40	-13.02	11.94	0.58	31.36	120	152	Peak
158.04	31.18	49.27	43.5	-12.32	12.73	1.01	31.83	165	295	Peak
170.65	29.62	48.62	43.5	-13.88	11.67	1.07	31.74	132	274	Peak
729.37	29.71	36.65	46	-16.29	21.23	3.43	31.6	165	295	Peak
746.83	28.5	34.87	46	-17.5	21.48	3.5	31.35	185	247	Peak
971.87	29.18	32.77	54	-24.82	23.91	4.34	31.84	132	265	Peak

Remarks:

- Emission Level = Read Level + Antenna Factor + Cable Loss - Preamp Factor
Margin Value = Emission Level – Limit value
- The other emission levels were very low against the limit.

Mode B

802.11g

EUT Test Condition		Measurement Detail	
Channel	Channel 11	Frequency Range	30 MHz ~ 1 GHz
Input Power	120 Vac, 60 Hz	Detector Function	Peak (PK) Quasi-Peak (QP)
Environmental Conditions	25 deg. C, 65 % RH	Tested By	Jisyong Wang

Antenna Polarity & Test Distance: Horizontal at 3 m										
Frequency (MHz)	Emission Level (dBuV/m)	Read Level (dBuV)	Limit (dBuV/m)	Margin (dB)	Antenna Factor (dB/m)	Cable Loss (dB)	Preamp Factor (dB)	Antenna Height (cm)	Table Angle (Degree)	Remark
44.55	32.82	49.85	40	-7.18	13.6	0.51	31.14	111	132	Peak
154.16	34.42	52.42	43.5	-9.08	12.72	1	31.72	165	285	Peak
170.65	32.26	51.26	43.5	-11.24	11.67	1.07	31.74	174	295	Peak
353.98	19.11	34.86	46	-26.89	14.24	1.9	31.89	132	265	Peak
789.51	27.48	33.17	46	-18.52	22.08	3.63	31.4	222	285	Peak
951.5	29.16	32.96	46	-16.84	23.8	4.24	31.84	201	145	Peak

Antenna Polarity & Test Distance: Vertical at 3 m										
Frequency (MHz)	Emission Level (dBuV/m)	Read Level (dBuV)	Limit (dBuV/m)	Margin (dB)	Antenna Factor (dB/m)	Cable Loss (dB)	Preamp Factor (dB)	Antenna Height (cm)	Table Angle (Degree)	Remark
44.55	32.79	49.82	40	-7.21	13.6	0.51	31.14	152	142	Peak
60.07	26.98	45.82	40	-13.02	11.94	0.58	31.36	256	321	Peak
153.19	33.77	51.75	43.5	-9.73	12.72	0.99	31.69	185	256	Peak
170.65	29.62	48.62	43.5	-13.88	11.67	1.07	31.74	111	147	Peak
337.49	17.49	33.65	46	-28.51	13.84	1.82	31.82	196	285	Peak
729.37	29.71	36.65	46	-16.29	21.23	3.43	31.6	1320	285	Peak

Remarks:

- Emission Level = Read Level + Antenna Factor + Cable Loss - Preamp Factor
Margin Value = Emission Level – Limit value
- The other emission levels were very low against the limit.

4.2 Conducted Emission Measurement

4.2.1 Limits of Conducted Emission Measurement

Frequency (MHz)	Conducted Limit (dBuV)	
	Quasi-Peak	Average
0.15 - 0.5	66 - 56	56 - 46
0.50 - 5.0	56	46
5.0 - 30.0	60	50

- Note: 1. The lower limit shall apply at the transition frequencies.
 2. The limit decreases in line with the logarithm of the frequency in the range of 0.15 to 0.50 MHz.

4.2.2 Test Instruments

Description & Manufacturer	Model No.	Serial No.	Date of Calibration	Due Date of Calibration
Test Receiver ROHDE & SCHWARZ	ESCI	100613	Nov. 23, 2017	Nov. 22, 2018
RF signal cable (with 10dB PAD) Woken	5D-FB	Cable-cond1-01	Sep. 05, 2017	Sep. 04, 2018
LISN/AMN ROHDE & SCHWARZ (EUT)	ENV216	101826	Feb. 26, 2018	Feb. 25, 2019
LISN/AMN ROHDE & SCHWARZ (Peripheral)	ESH3-Z5	100311	Aug. 15, 2017	Aug. 14, 2018
Software ADT	BV ADT_Cond_ V7.3.7.4	NA	NA	NA

- Note: 1. The calibration interval of the above test instruments is 12 months and the calibrations are traceable to NML/ROC and NIST/USA.
 2. The test was performed in HwaYa Shielded Room 1.
 3. The VCCI Site Registration No. is C-2040.

4.2.3 Test Procedures

- a. The EUT was placed 0.4 meters from the conducting wall of the shielded room with EUT being connected to the power mains through a line impedance stabilization network (LISN). Other support units were connected to the power mains through another LISN. The two LISNs provide 50 ohm/50 uH of coupling impedance for the measuring instrument.
- b. Both lines of the power mains connected to the EUT were checked for maximum conducted interference.
- c. The frequency range from 150 kHz to 30 MHz was searched. Emission levels under (Limit – 20 dB) was not recorded.

Note: The resolution bandwidth and video bandwidth of test receiver is 9 kHz for quasi-peak detection (QP) and average detection (AV) at frequency 0.15 MHz – 30 MHz.

4.2.4 Deviation from Test Standard

No deviation.

4.2.5 Test Setup

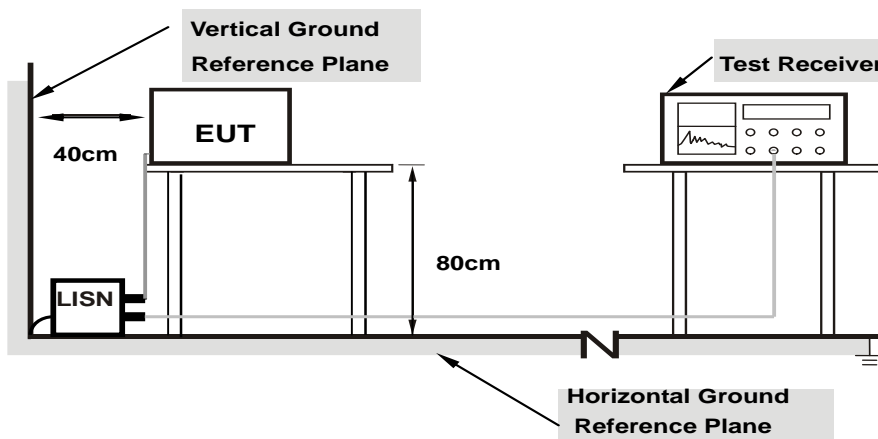

Note: 1.Support units were connected to second LISN.

For the actual test configuration, please refer to the attached file (Test Setup Photo).

4.2.6 EUT Operating Conditions

- a. Placed the EUT on a testing table.
- b. Use the software to control the EUT under transmission condition continuously at specific channel frequency.

4.2.7 Test Results

Frequency Range	150kHz ~ 30MHz	Detector Function & Resolution Bandwidth	Quasi-Peak (QP) / Average (AV), 9kHz
Input Power	120Vac, 60Hz	Environmental Conditions	25°C, 65%RH
Tested by	Getaz Yang	Test Date	2018/6/6

Phase Of Power : Line (L)										
No	Frequency (MHz)	Correction Factor (dB)	Reading Value (dBuV)		Emission Level (dBuV)		Limit (dBuV)		Margin (dB)	
			Q.P.	AV.	Q.P.	AV.	Q.P.	AV.	Q.P.	AV.
1	0.16967	10.10	20.75	8.86	30.85	18.96	64.98	54.98	-34.13	-36.02
2	0.19305	10.10	15.81	4.37	25.91	14.47	63.90	53.90	-37.99	-39.43
3	3.71592	10.27	12.28	0.57	22.55	10.84	56.00	46.00	-33.45	-35.16
4	9.90154	10.61	18.61	4.01	29.22	14.62	60.00	50.00	-30.78	-35.38
5	11.95429	10.74	17.40	2.17	28.14	12.91	60.00	50.00	-31.86	-37.09
6	14.97281	10.92	16.72	2.08	27.64	13.00	60.00	50.00	-32.36	-37.00

Remarks:

1. Q.P. and AV. are abbreviations of quasi-peak and average individually.
2. The emission levels of other frequencies were very low against the limit.
3. Margin value = Emission level – Limit value
4. Correction factor = Insertion loss + Cable loss
5. Emission Level = Correction Factor + Reading Value

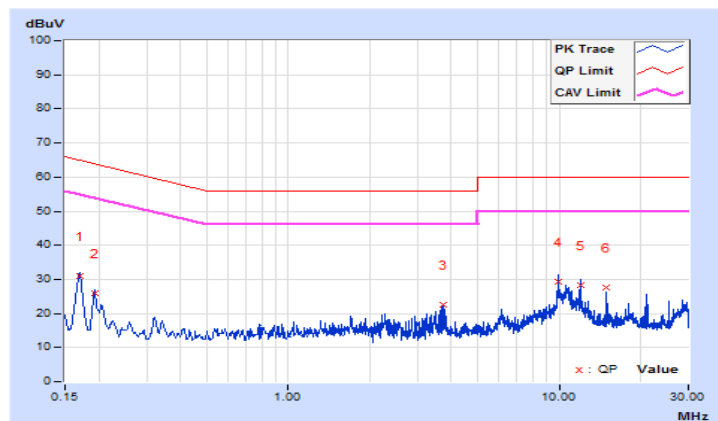

Frequency Range	150kHz ~ 30MHz	Detector Function & Resolution Bandwidth	Quasi-Peak (QP) / Average (AV), 9kHz
Input Power	120Vac, 60Hz	Environmental Conditions	25°C, 65%RH
Tested by	Getaz Yang	Test Date	2018/6/6

Phase Of Power : Neutral (N)										
No	Frequency (MHz)	Correction Factor (dB)	Reading Value (dBuV)		Emission Level (dBuV)		Limit (dBuV)		Margin (dB)	
			Q.P.	AV.	Q.P.	AV.	Q.P.	AV.	Q.P.	AV.
1	0.16967	10.10	13.92	2.79	24.02	12.89	64.98	54.98	-40.96	-42.09
2	0.34550	10.11	10.99	0.20	21.10	10.31	59.07	49.07	-37.97	-38.76
3	3.52042	10.24	11.27	0.56	21.51	10.80	56.00	46.00	-34.49	-35.20
4	6.17922	10.36	12.32	0.86	22.68	11.22	60.00	50.00	-37.32	-38.78
5	9.89372	10.51	17.81	5.41	28.32	15.92	60.00	50.00	-31.68	-34.08
6	20.93947	10.95	15.89	0.83	26.84	11.78	60.00	50.00	-33.16	-38.22

Remarks:

1. Q.P. and AV. are abbreviations of quasi-peak and average individually.
2. The emission levels of other frequencies were very low against the limit.
3. Margin value = Emission level – Limit value
4. Correction factor = Insertion loss + Cable loss
5. Emission Level = Correction Factor + Reading Value

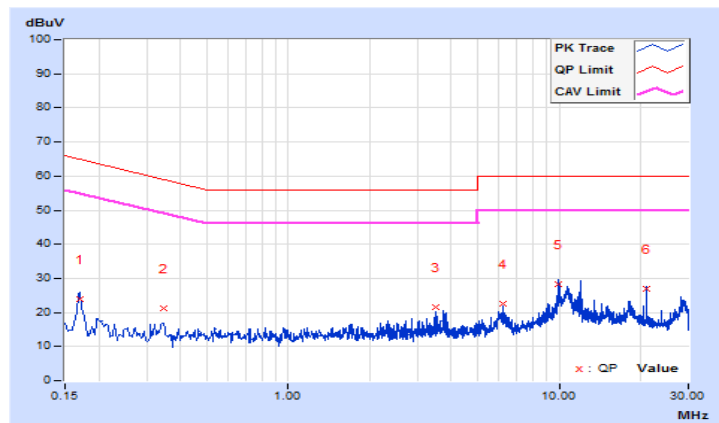

4.3 6 dB Bandwidth Measurement

4.3.1 Limits of 6 dB Bandwidth Measurement

The minimum of 6 dB Bandwidth Measurement is 0.5 MHz.

4.3.2 Test Setup

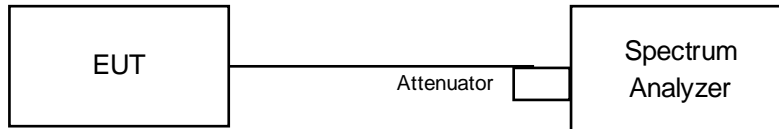

4.3.3 Test Instruments

Refer to section 4.1.2 to get information of above instrument.

4.3.4 Test Procedure

- Set resolution bandwidth (RBW) = 100 kHz
- Set the video bandwidth (VBW) $\geq 3 \times$ RBW, Detector = Peak.
- Trace mode = max hold.
- Sweep = auto couple.
- Measure the maximum width of the emission that is constrained by the frequencies associated with the two amplitude points (upper and lower) that are attenuated by 6 dB relative to the maximum level measured in the fundamental emission

4.3.5 Deviation from Test Standard

No deviation.

4.3.6 EUT Operating Conditions

The software provided by client to enable the EUT under transmission condition continuously at lowest, middle and highest channel frequencies individually.

4.3.7 Test Results

802.11b

Channel	Frequency (MHz)	6 dB Bandwidth (MHz)	Minimum Limit (MHz)	Pass / Fail
1	2412	9.04	0.5	Pass
6	2437	8.14	0.5	Pass
11	2462	8.59	0.5	Pass

802.11g

Channel	Frequency (MHz)	6 dB Bandwidth (MHz)	Minimum Limit (MHz)	Pass / Fail
1	2412	15.23	0.5	Pass
6	2437	15.80	0.5	Pass
11	2462	15.23	0.5	Pass

802.11n (HT20)

Channel	Frequency (MHz)	6 dB Bandwidth (MHz)	Minimum Limit (MHz)	Pass / Fail
1	2412	15.22	0.5	Pass
6	2437	16.72	0.5	Pass
11	2462	15.22	0.5	Pass

Spectrum Plot of Worst Value

802.11b

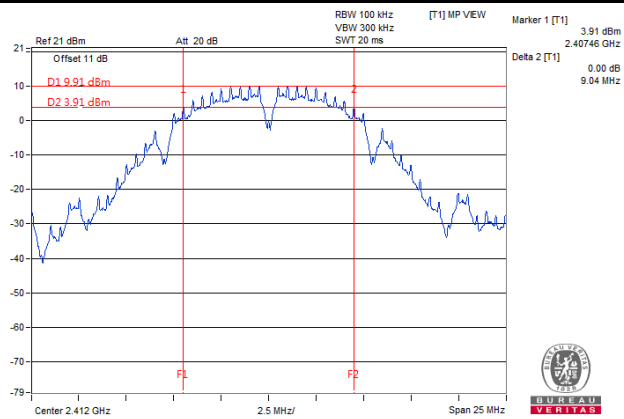

802.11g

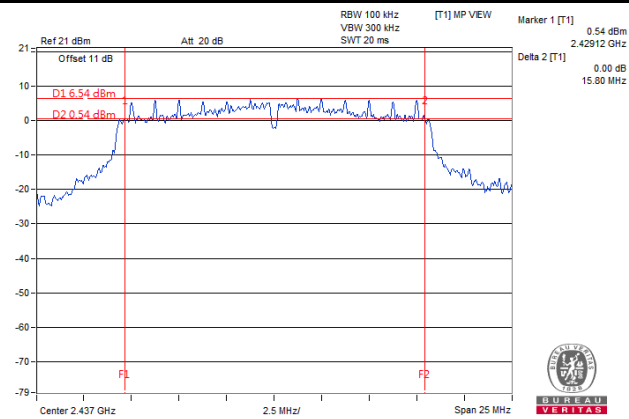

802.11n (HT20)

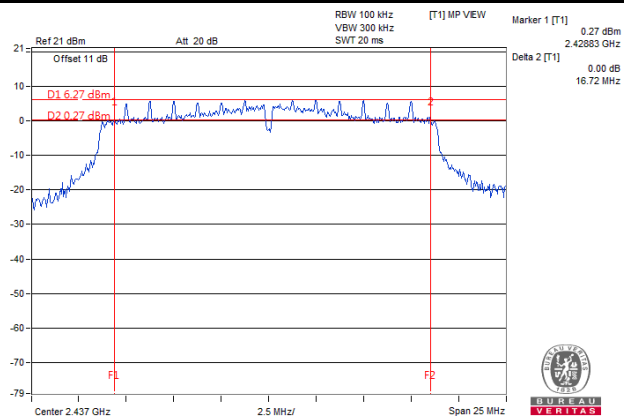

4.4 Occupied Bandwidth Measurement

4.4.1 Test Setup

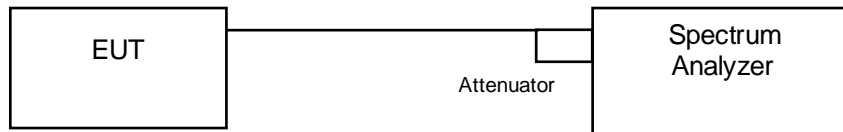

4.4.2 Test Instruments

Refer to section 4.1.2 to get information of above instrument.

4.4.3 Test Procedure

The transmitter output was connected to the spectrum analyzer through an attenuator. The bandwidth of the fundamental frequency was measured by spectrum analyzer with resolution bandwidth in the range of 1 % to 5 % of the anticipated emission bandwidth, and a video bandwidth at least 3x the resolution bandwidth and set the detector to PEAK. The width of a frequency band such that, below the lower and above the upper frequency limits, the mean powers emitted are each equal to a specified percentage 0.5 % of the total mean power of a given emission.

4.4.4 Deviation from Test Standard

No deviation.

4.4.5 EUT Operating Conditions

The software provided by client to enable the EUT under transmission condition continuously at lowest, middle and highest channel frequencies individually.

4.4.6 Test Results

802.11b

Channel	Frequency (MHz)	Occupied Bandwidth (MHz)	Pass / Fail
1	2412	12.12	Pass
6	2437	12.12	Pass
11	2462	12.24	Pass

802.11g

Channel	Frequency (MHz)	Occupied Bandwidth (MHz)	Pass / Fail
1	2412	17.04	Pass
6	2437	17.76	Pass
11	2462	17.16	Pass

802.11n (HT20)

Channel	Frequency (MHz)	Occupied Bandwidth (MHz)	Pass / Fail
1	2412	18.00	Pass
6	2437	18.48	Pass
11	2462	18.12	Pass

Spectrum Plot of Worst Value

802.11b

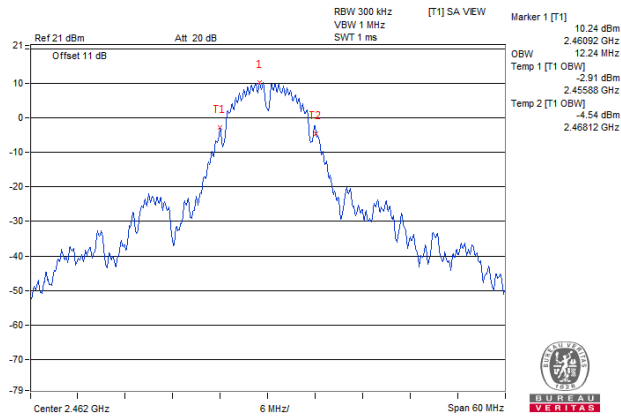

802.11g

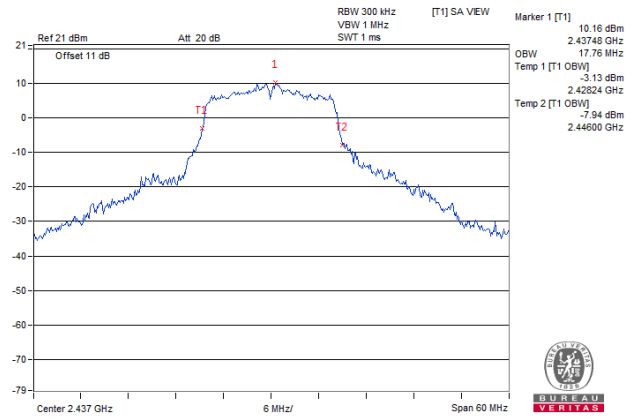

802.11n (HT20)

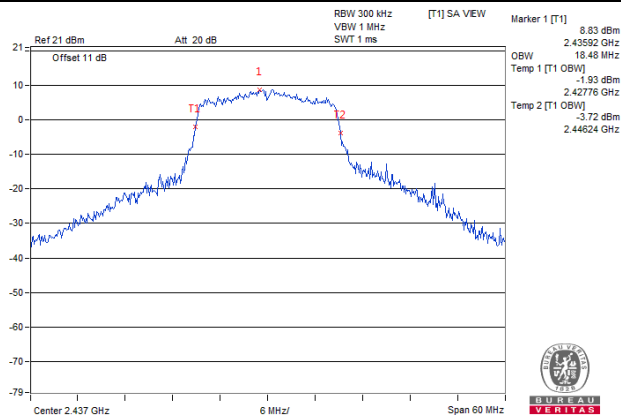

4.5 Conducted Output Power Measurement

4.5.1 Limits of Conducted Output Power Measurement

For systems using digital modulation in the 2400–2483.5 MHz bands: 1 Watt (30 dBm)

4.5.2 Test Setup

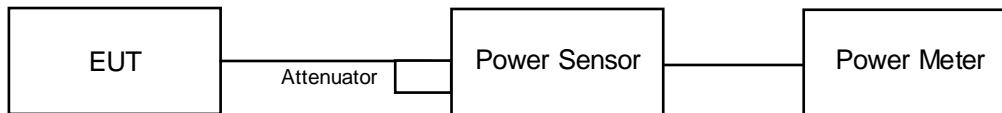

4.5.3 Test Instruments

Refer to section 4.1.2 to get information of above instrument.

4.5.4 Test Procedures

A peak power sensor was used on the output port of the EUT. A power meter was used to read the response of the peak power sensor. Record the power level.

4.5.5 Deviation from Test Standard

No deviation.

4.5.6 EUT Operating Conditions

The software provided by client to enable the EUT under transmission condition continuously at lowest, middle and highest channel frequencies individually.

4.5.7 Test Results

802.11b

Channel	Frequency (MHz)	Peak Power (mW)	Peak Power (dBm)	Limit (dBm)	Pass / Fail
1	2412	66.527	18.23	30	Pass
6	2437	142.233	21.53	30	Pass
11	2462	62.951	17.99	30	Pass

802.11g

Channel	Frequency (MHz)	Peak Power (mW)	Peak Power (dBm)	Limit (dBm)	Pass / Fail
1	2412	110.408	20.43	30	Pass
6	2437	220.8	23.44	30	Pass
11	2462	109.396	20.39	30	Pass

802.11n (HT20)

Channel	Frequency (MHz)	Peak Power (mW)	Peak Power (dBm)	Limit (dBm)	Pass / Fail
1	2412	138.357	21.41	30	Pass
6	2437	218.776	23.40	30	Pass
11	2462	127.35	21.05	30	Pass

4.6 Power Spectral Density Measurement

4.6.1 Limits of Power Spectral Density Measurement

The Maximum of Power Spectral Density Measurement is 8 dBm.

4.6.2 Test Setup



4.6.3 Test Instruments

Refer to section 4.1.2 to get information of above instrument.

4.6.4 Test Procedure

- a. Set analyzer center frequency to DTS channel center frequency.
- b. Set the span to 1.5 times the DTS bandwidth.
- c. Set the RBW to: $3 \text{ kHz} \leq \text{RBW} \leq 100 \text{ kHz}$.
- d. Set the VBW $\geq 3 \times \text{RBW}$.
- e. Detector = peak.
- f. Sweep time = auto couple.
- g. Trace mode = max hold.
- h. Allow trace to fully stabilize.
- i. Use the peak marker function to determine the maximum amplitude level within the RBW.

4.6.5 Deviation from Test Standard

No deviation.

4.6.6 EUT Operating Condition

The software provided by client to enable the EUT under transmission condition continuously at lowest, middle and highest channel frequencies individually.

4.6.7 Test Results

802.11b

Channel	Frequency (MHz)	PSD (dBm/3 kHz)	Limit (dBm/3 kHz)	Pass / Fail
1	2412	-2.01	8	Pass
6	2437	-1.77	8	Pass
11	2462	-2.27	8	Pass

802.11g

Channel	Frequency (MHz)	PSD (dBm/3 kHz)	Limit (dBm/3 kHz)	Pass / Fail
1	2412	-4.79	8	Pass
6	2437	-5.47	8	Pass
11	2462	-5.06	8	Pass

802.11n (HT20)

Channel	Frequency (MHz)	PSD (dBm/3 kHz)	Limit (dBm/3 kHz)	Pass / Fail
1	2412	-4.63	8	Pass
6	2437	-5.21	8	Pass
11	2462	-5.18	8	Pass

Spectrum Plot of Worst Value

802.11b

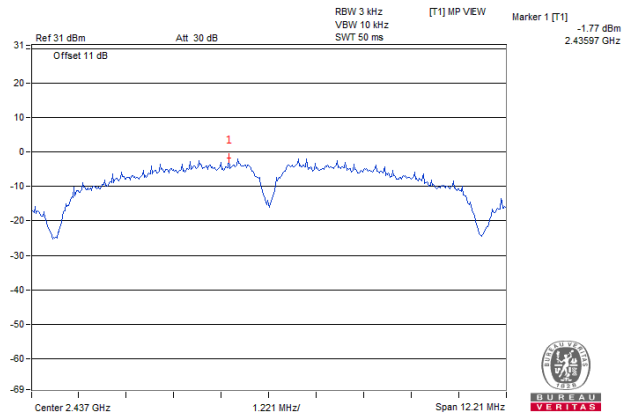

802.11g

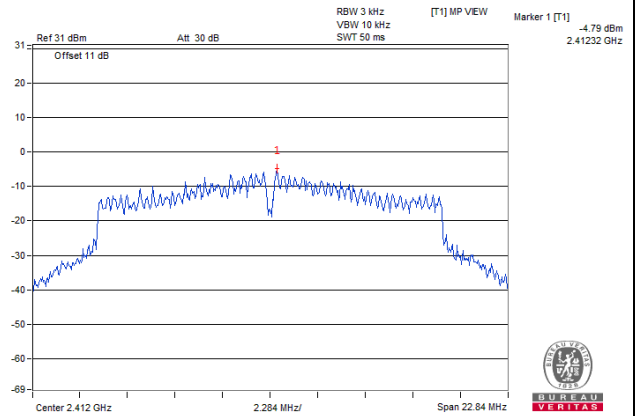

802.11n (HT20)

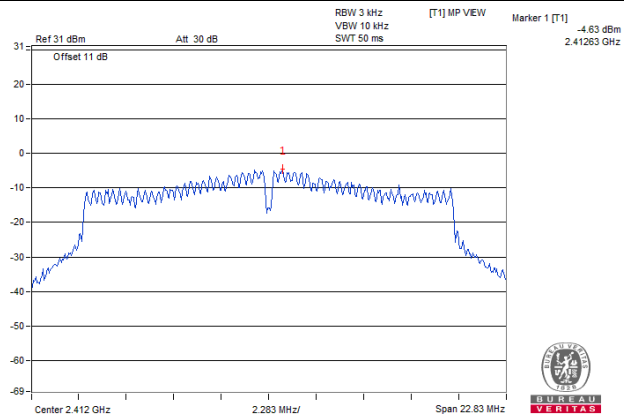

4.7 Conducted Out of Band Emission Measurement

4.7.1 Limits of Conducted Out of Band Emission Measurement

Below -20 dB of the highest emission level of operating band (in 100 kHz Resolution Bandwidth).

4.7.2 Test Setup

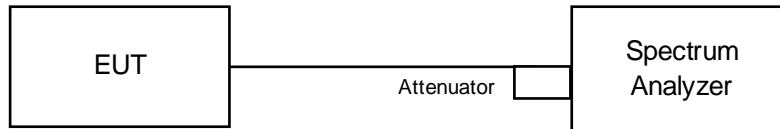

4.7.3 Test Instruments

Refer to section 4.1.2 to get information of above instrument.

4.7.4 Test Procedure

MEASUREMENT PROCEDURE REF

1. Set the RBW = 100 kHz.
2. Set the VBW \geq 300 kHz.
3. Detector = peak.
4. Sweep time = auto couple.
5. Trace mode = max hold.
6. Allow trace to fully stabilize.
7. Use the peak marker function to determine the maximum power level in any 100 kHz band segment within the fundamental EBW.

MEASUREMENT PROCEDURE OOB

1. Set RBW = 100 kHz.
2. Set VBW \geq 300 kHz.
3. Detector = peak.
4. Sweep = auto couple.
5. Trace Mode = max hold.
6. Allow trace to fully stabilize.
7. Use the peak marker function to determine the maximum amplitude level.

4.7.5 Deviation from Test Standard

No deviation.

4.7.6 EUT Operating Condition

The software provided by client to enable the EUT under transmission condition continuously at lowest, middle and highest channel frequencies individually.

4.7.7 Test Results

The spectrum plots are attached on the following images. D1 line indicates the highest level, and D2 line indicates the 20 dB offset below D1. It shows compliance with the requirement.

802.11b

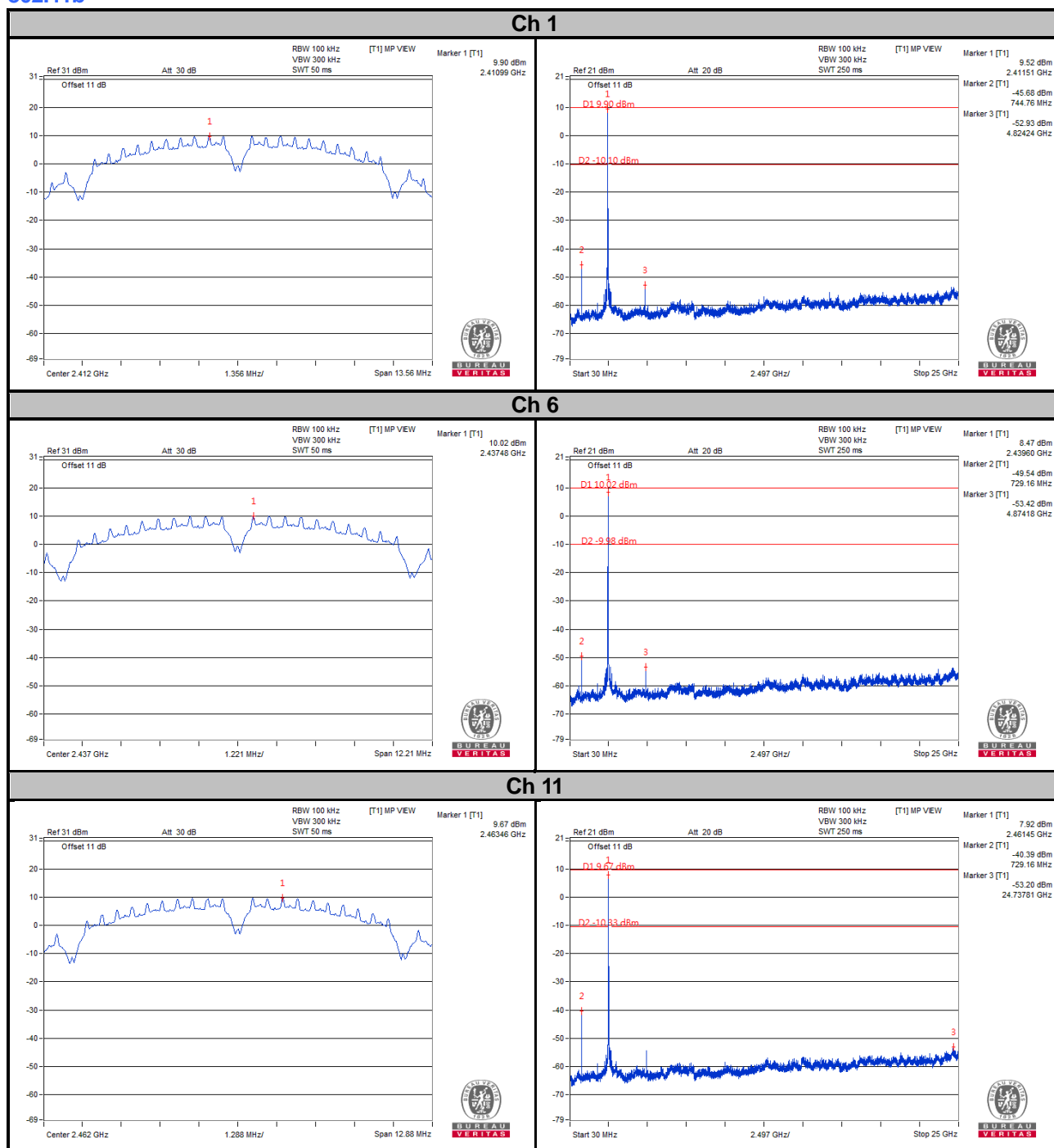

Ch 1 Band Edge

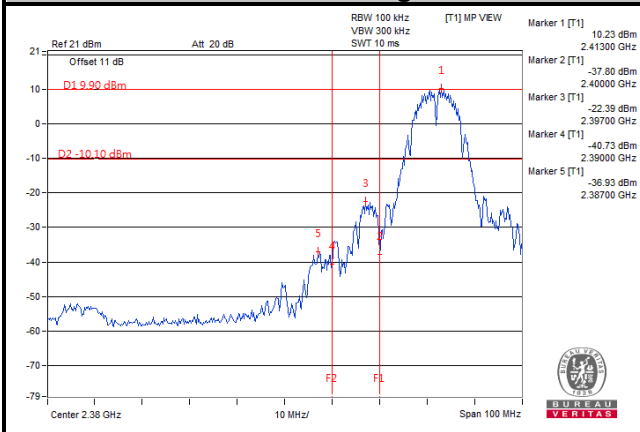

Ch 11 Band Edge

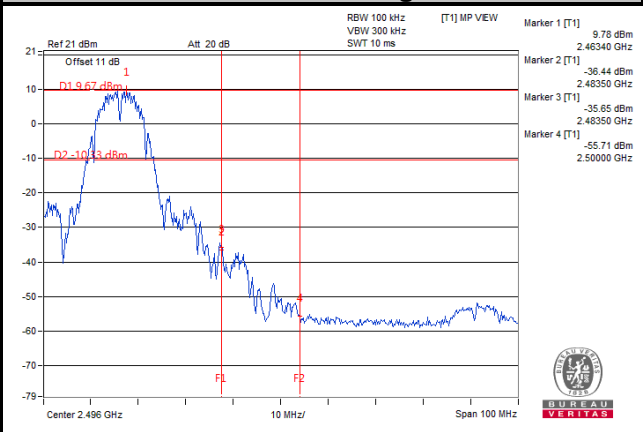

802.11g

Ch 1

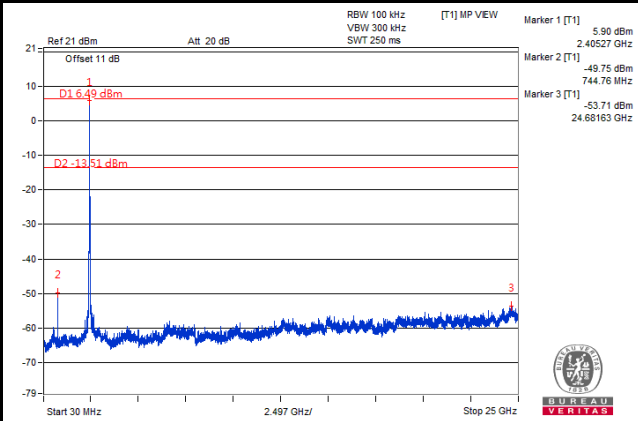
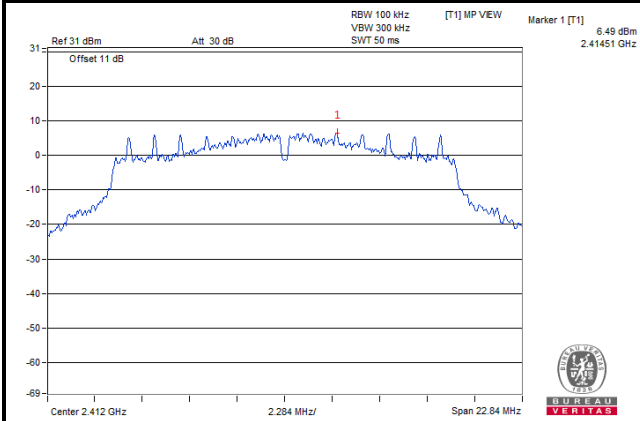

Ch 6

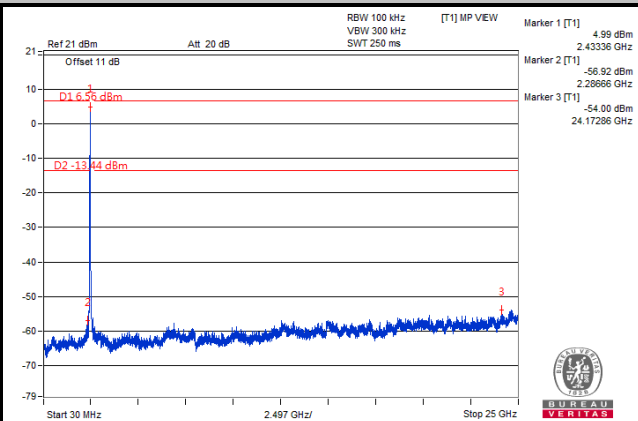
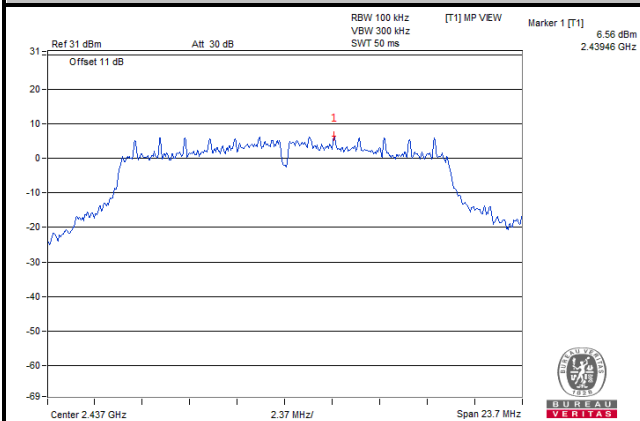

Ch 11

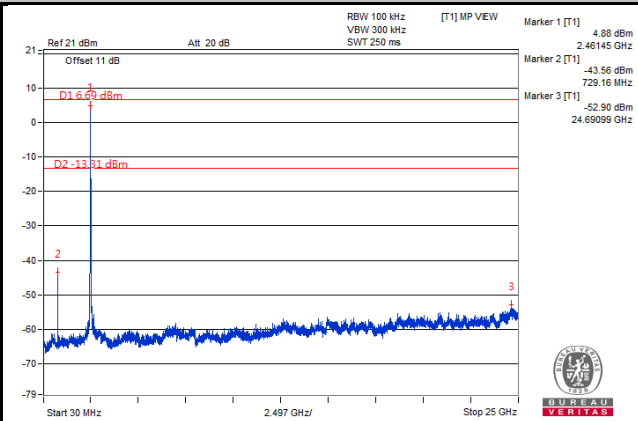
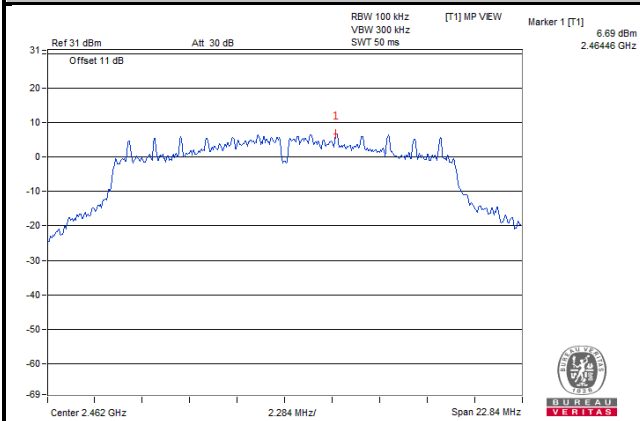

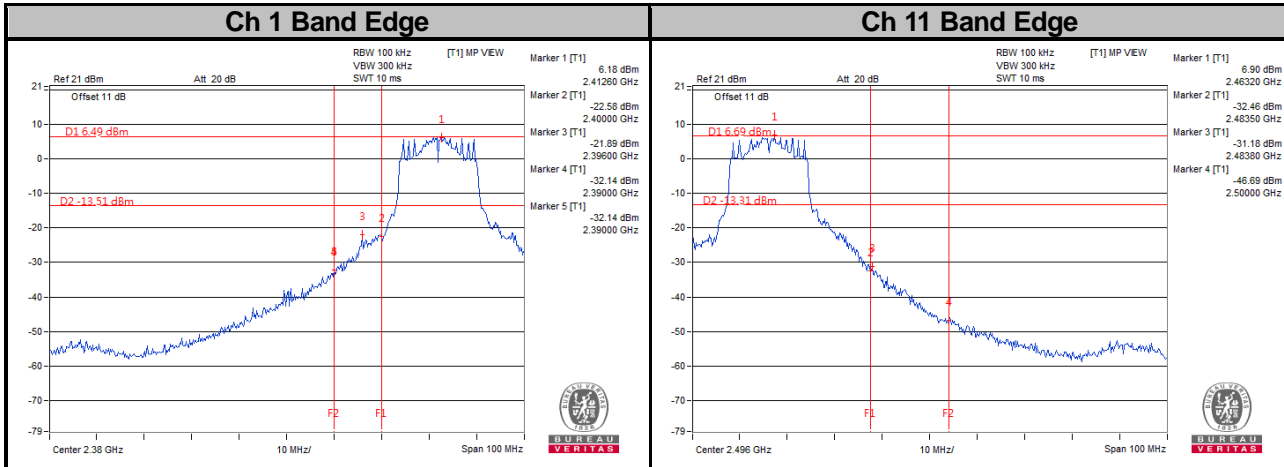

802.11n (HT20)

Ch 1

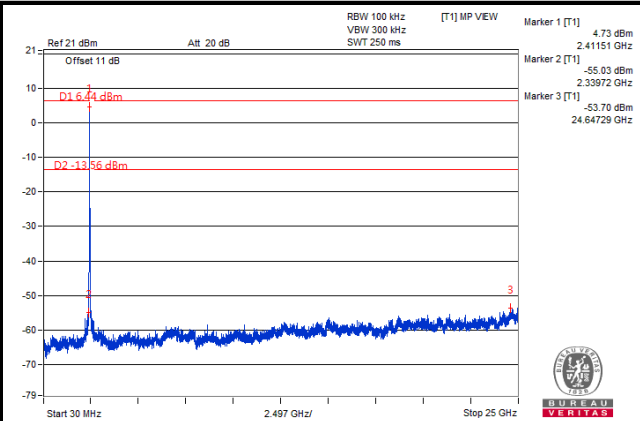
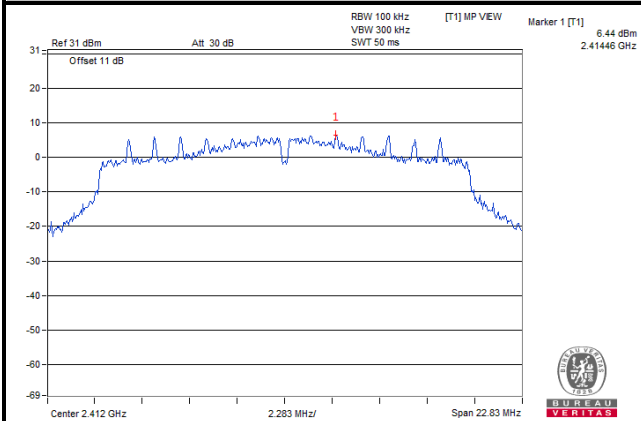

Ch 6

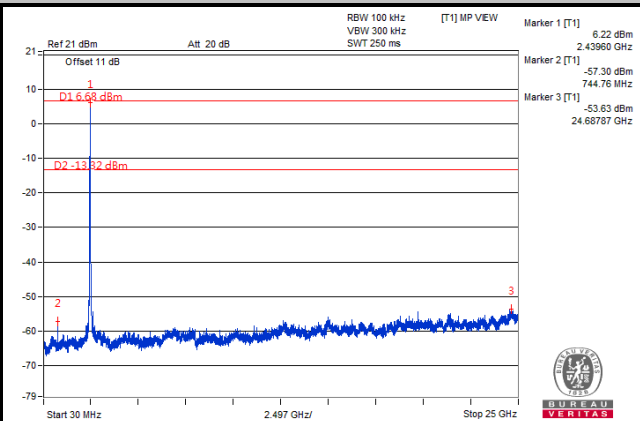
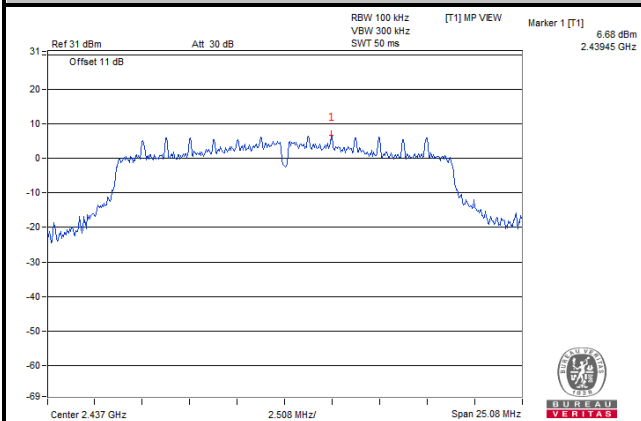

Ch 11

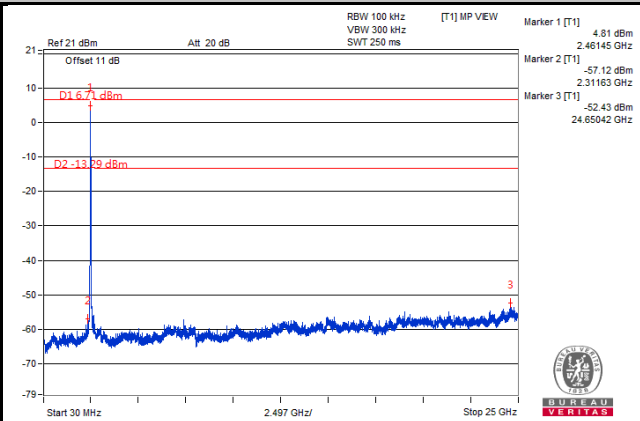
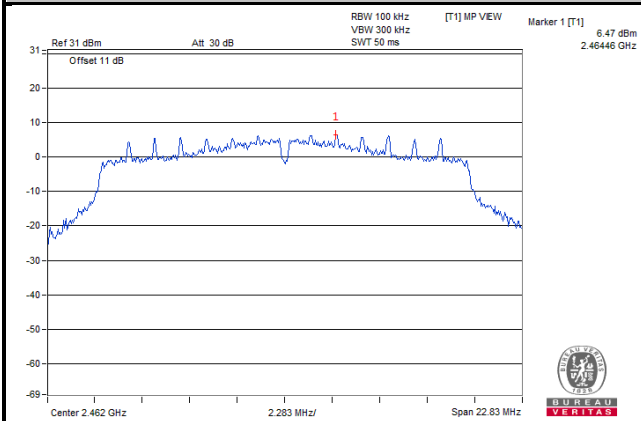

Ch 1 Band Edge

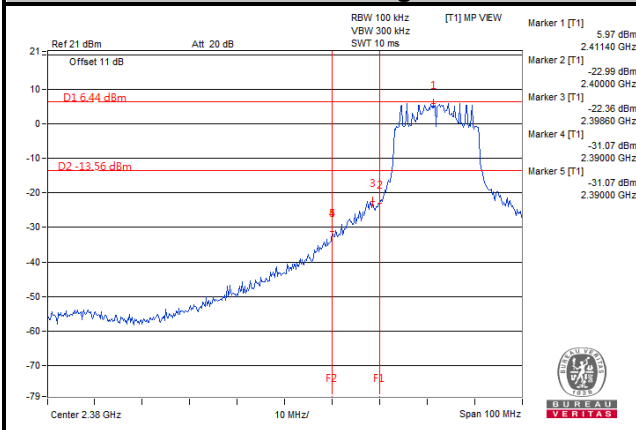

Ch 11 Band Edge

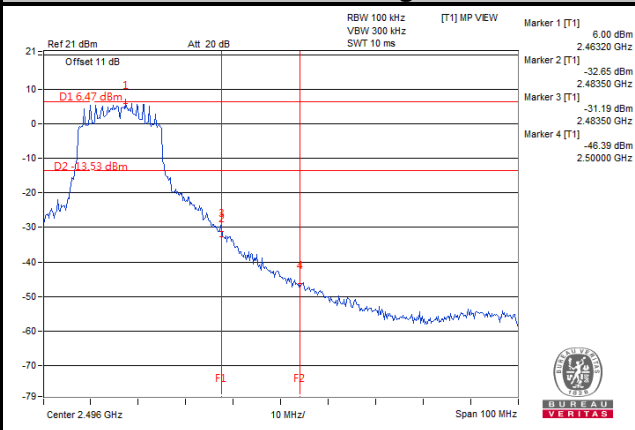

5 Pictures of Test Arrangements

Please refer to the attached file (Test Setup Photo).

Appendix – Information on the Testing Laboratories

We, Bureau Veritas Consumer Products Services (H.K.) Ltd., Taoyuan Branch, were founded in 1988 to provide our best service in EMC, Radio, Telecom and Safety consultation. Our laboratories are FCC recognized accredited test firms and accredited according to ISO/IEC 17025.

If you have any comments, please feel free to contact us at the following:

Linko EMC/RF Lab

Tel: 886-2-26052180

Fax: 886-2-26051924

Hsin Chu EMC/RF/Telecom Lab

Tel: 886-3-6668565

Fax: 886-3-6668323

Hwa Ya EMC/RF/Safety Lab

Tel: 886-3-3183232

Fax: 886-3-3270892

Email: service.adt@tw.bureauveritas.com

Web Site: www.bureauveritas-adt.com

The address and road map of all our labs can be found in our web site also.

--- END ---