

INPUT SETUP

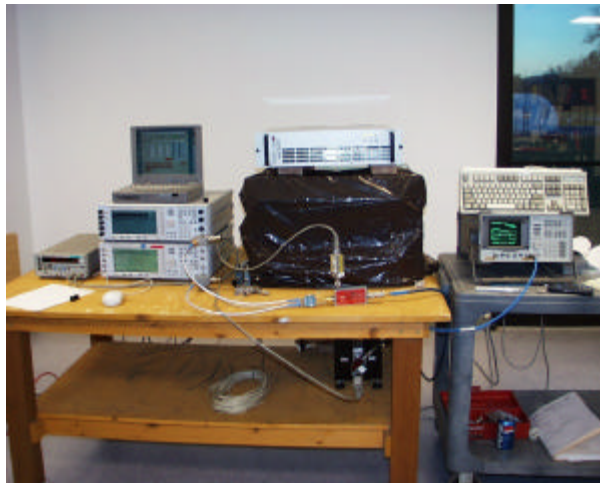

OUTPUT SETUP

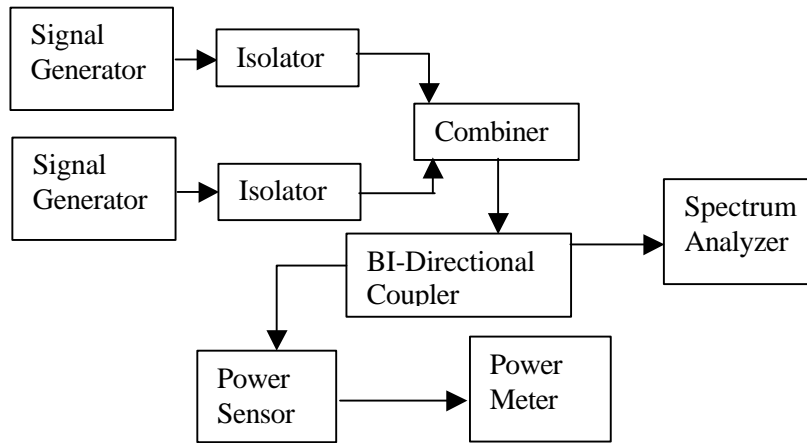
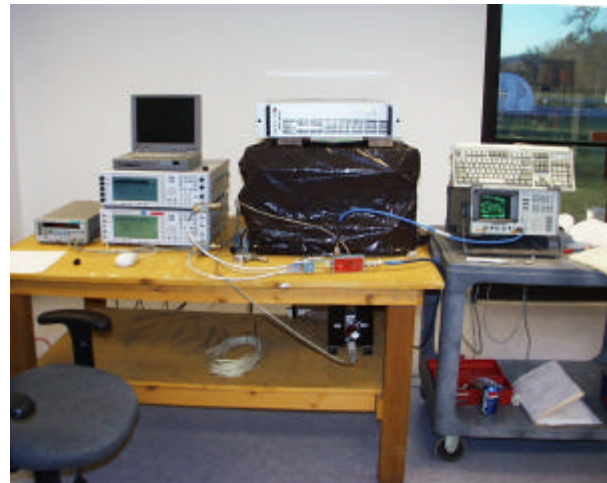

INPUT SETUP

TEST PROCEDURE

The EUT's occupied bandwidth output plot is compared with the input source plot to check that no distortion is created when the input signal is amplified by the EUT. Identical bandwidths, spans and center frequencies are used for both plots. Reference levels and attenuation are adjusted.

RESULT

Plots of the input and output are included. Please refer to spectrum plots below.

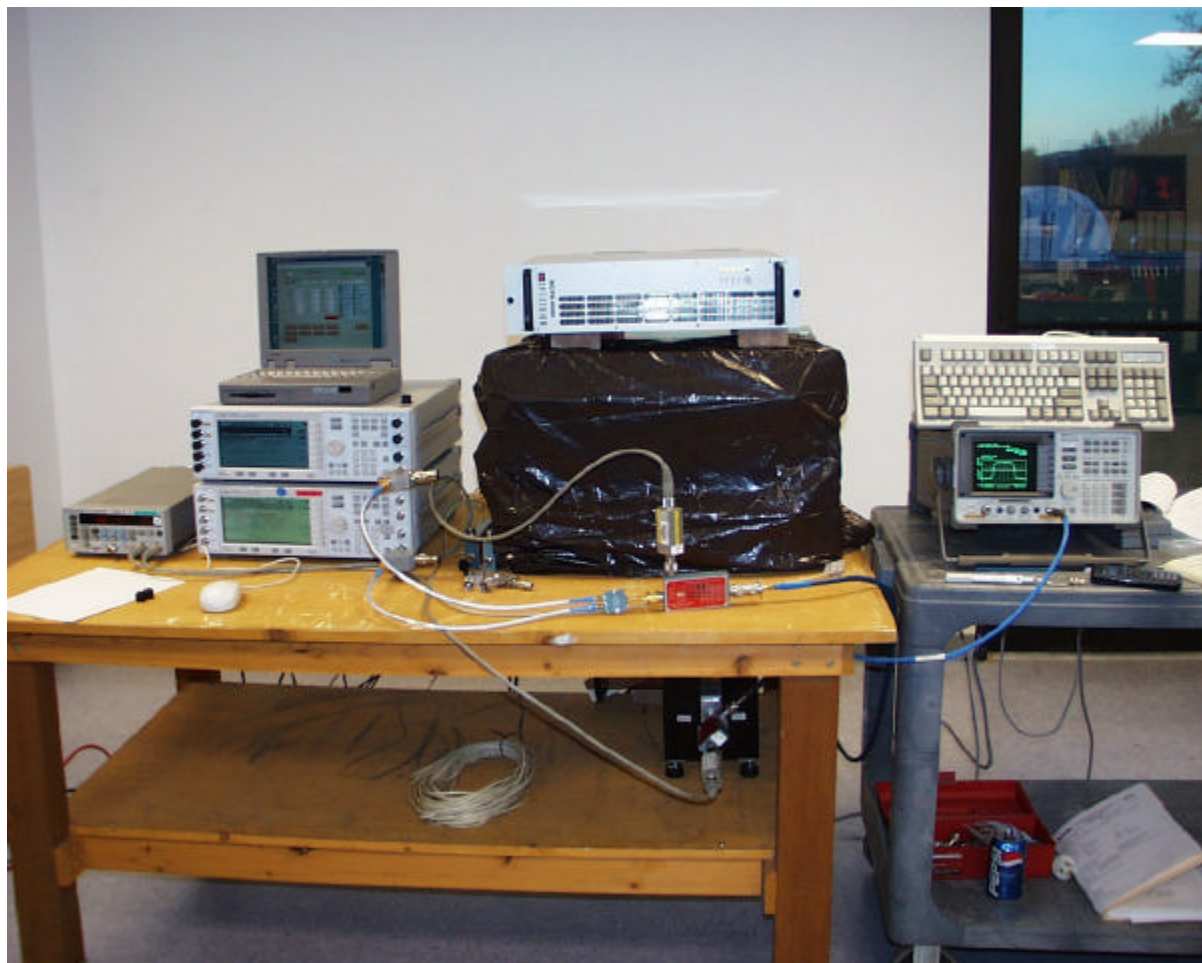

TEST PROCEDURE

- 1) Two balanced signals were applied to the RF input. One set as close as possible to the bottom of the block edge and one set as close as possible to the top of the block edge and one set of each ends of the block edges. Set the RES BW to 1% of the emission bandwidth to show compliance with the -13dBm limit, in the 1 MHz bands immediately outside and adjacent to the top and bottom edges of the frequency block.
- 2) For the Out-of-Band measurements a 1 MHz RES BW was used to scan from 15 MHz to $10f_0$ of the fundamental carrier for all frequency block. A display line was placed at -13dBm to show compliance.

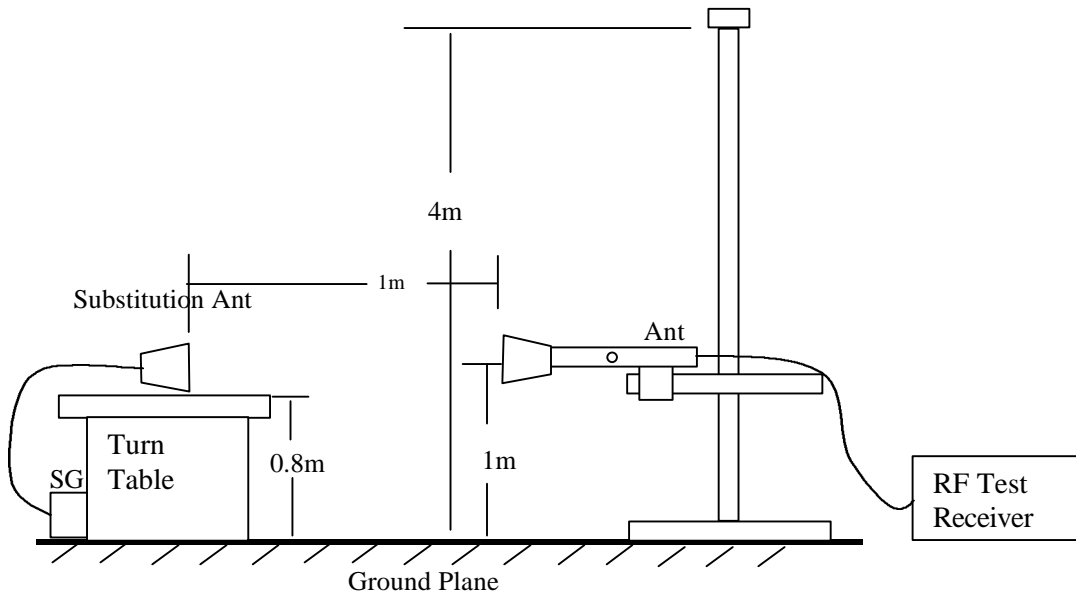
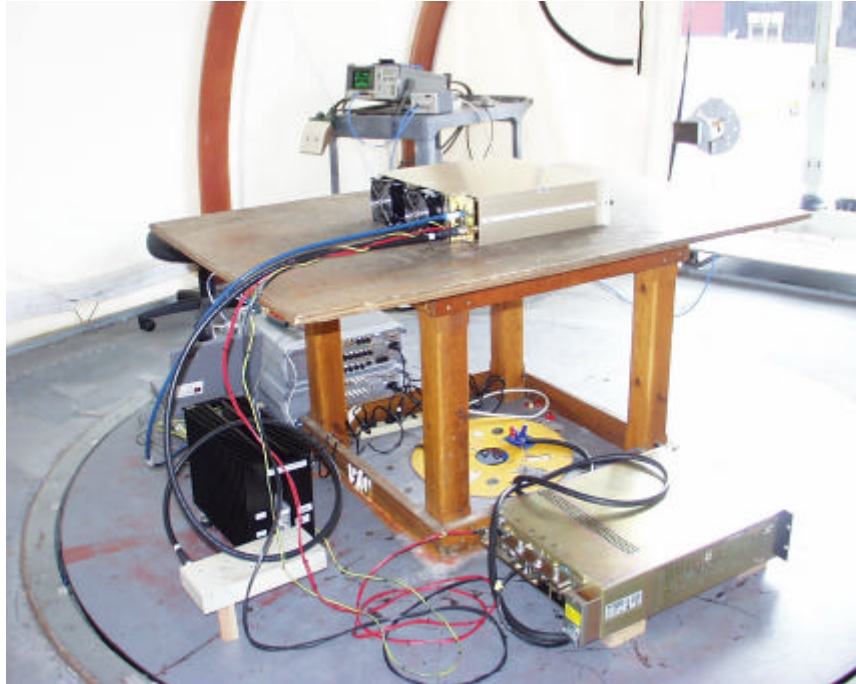

Fig 2: Radiated Emission – Substitution Method set-up



1 - 18 GHz Radiated Emission Setup



18 – 20 GHz Radiated Emission Setup



1 – 18 GHz Substitution Method Setup



18 – 20 GHz Substitution Method Setup

TEST PROCEDURE

- 1). On a test site, the EUT shall be placed on a turntable, and in the position closest to the normal use as declared by the user.
- 2). The test antenna shall be oriented initially for vertical polarization located 1m from the EUT to correspond to the frequency of the transmitter.
- 3). The output of the test antenna shall be connected to the measuring receiver and either a peak or average detector was used for the measurement as indicated on the report. The detector selection is based on how close the emission level was approaching the limit.
- 4). The transmitter shall be switched on, if possible, without the modulation and the measurement receiver shall be tuned to the frequency of the transmitter under test.
- 5). The test antenna shall be raised and lowered through the specified range of height until a maximum signal level is detected by the measuring receiver.
- 6). The transmitter shall than be rotated through 360° in the horizontal plane, until the maximum signal level is detected by the measuring receiver.
- 7). The test antenna shall be raised and lowered again through the specified range of height until a maximum signal level is detected by the measuring receiver.
- 8). The maximum signal level detected by the measuring receiver shall be noted.
- 9). The transmitter shall be replaced by a substitution antenna.
- 10). The substitution antenna shall be oriented for vertical polarization.
- 11). The substitution antenna shall be connected to a calibrated signal generator.
- 12). If necessary, the input attenuator setting of the measuring receiver shall be adjusted in order to increase the sensitivity of the measuring receiver.
- 13). The test antenna shall be raised and lowered through the specified range of the height to ensure that the maximum signal is received.