



FCC PART 24 TYPE APPROVAL EMI MEASUREMENT AND TEST REPORT

For

REMEC, Inc.

1590 Buckeye Drive,
Milpitas, CA 95035

FCC ID: I2ODPA4040E

This Report Concerns: <input checked="" type="checkbox"/> Class II Permissive Change	Equipment Type: PCS GSM/EDGE Dual Single Channel Power Amplifier
Test Engineer: Ming Jin / 	
Report No.: R0407121	
Report Date: 2004-07-26	
Reviewed By: Ling Zhang / 	
Prepared By: Bay Area Compliance Laboratory Corporation (BACL) 230 Commercial Street Sunnyvale, CA 94085 Tel: (408) 732-9162 Fax: (408) 732 9164	

Note: The test report is specially limited to the above company and the product model only. It may not be duplicated without prior written consent of Bay Area Compliance Laboratory Corporation. This report **must not** be used by the client to claim product certification, approval, or endorsement by NVLAP, NIST or any agency of the US Government.

TABLE OF CONTENTS

GENERAL INFORMATION.....4

 PRODUCT DESCRIPTION FOR EQUIPMENT UNDER TEST (EUT)4

 OBJECTIVE4

 RELATED SUBMITTAL(S)/GRANT(S).....4

 TEST METHODOLOGY4

 TEST FACILITY4

SYSTEM TEST CONFIGURATION.....6

 JUSTIFICATION6

 BLOCK DIAGRAM.....6

 EQUIPMENT MODIFICATIONS6

 LOCAL SUPPORT EQUIPMENT LIST AND DETAILS6

 EXTERNAL I/O CABLING LIST AND DETAILS6

 POWER SUPPLY INFORMATION.....6

 TEST SETUP BLOCK DIAGRAM.....7

SUMMARY OF TEST RESULTS8

§2.1047 - MODULATION CHARACTERISTIC9

§2.1053 - SPURIOUS RADIATED EMISSIONS10

 APPLICABLE STANDARD10

 TEST PROCEDURE10

 TEST EQUIPMENT LIST AND DETAILS.....10

 ENVIRONMENTAL CONDITIONS10

 TEST RESULT11

§2.1046, & §24.232 - RF POWER OUTPUT.....13

 APPLICABLE STANDARD13

 TEST PROCEDURE13

 TEST EQUIPMENT LIST AND DETAILS.....13

 ENVIRONMENTAL CONDITIONS13

 TEST RESULTS14

§2.1049, & §24.238(B) - EMISSION BANDWIDTH.....15

 APPLICABLE STANDARDS15

 TEST PROCEDURE15

 TEST EQUIPMENT15

 ENVIRONMENTAL CONDITIONS15

 TEST RESULTS15

§2.1051, & §24.238(A) - SPURIOUS EMISSIONS AT ANTENNA TERMINALS.....26

 APPLICABLE STANDARD26

 TEST PROCEDURE26

 TEST EQUIPMENT LIST AND DETAILS.....26

 ENVIRONMENTAL CONDITIONS26

 TEST RESULTS26

§2.1055 (A), §2.1055 (D), & §24.235 - FREQUENCY STABILITY33

§24.238 – BAND EDGE.....34

 APPLICABLE STANDARD34

 TEST PROCEDURE34

 TEST EQUIPMENT LIST AND DETAILS.....34

 ENVIRONMENTAL CONDITIONS34

 TEST RESULTS34

TWO-TONE TEST.....37

 APPLICABLE STANDARDS37

 TEST PROCEDURE37

TEST EQUIPMENT.....	37
TEST RESULTS	37

GENERAL INFORMATION

Product Description for Equipment Under Test (EUT)

The REMEC product, FCC ID:I2ODPA4040E, or “EUT” as referred to in this report, is a PCS GSM/EDGE Dual Single Channel Power Amplifier, which measures approximately 12”(L) x 17.5”(W) x 5.94”(H). The EUT operates at the frequency of 1930.4 – 1989.6 MHz, maximum output power (ERP) 49.49dBm (88.92W) per carrier, frequency tolerance 2.5ppm and emission designator GXW and G7W.

** The test data gathered are from typical production sample, serial number: 10000002, provided by the manufacturer.*

Objective

This type approval report is prepared on behalf of *REMEC* in accordance with Part 2, Subpart J, and Part 24 Subpart E of the Federal Communication Commissions rules.

The objective is to determine compliance with FCC rules for output power, modulation characteristic, occupied bandwidth, spurious emission at antenna terminal, field strength of spurious radiation, frequency stability, band edge and radiated margin.

This is a Class II permissive change application, the testing is to be performed with a Nortel S8000 Base Transceiver Station as the signal source and that these results will compliment the original FCC certification for this product, which used an alternative signal source.

Related Submittal(s)/Grant(s)

The application was originally granted on 2003-07-16.

Test Methodology

All tests and measurements indicated in this document were performed in accordance with the Code of Federal Regulations Title 47 Part 2, Sub-part J as well as the following parts:

Part 24 Subpart E - PCS

Applicable Standards: TIA EIA 137-A, TIA EIA 98-C, ANSI 63.4-1992, and TIA/EIA-603A.

All radiated and conducted emissions measurements were performed at Bay Area Compliance Laboratory, Corp. The radiated testing was performed at an antenna-to-EUT distance of 3 meters, except as noted below.

Test Facility

The majority of the testing was performed at the Cingular lab located in the building at 4420 Rosewood Dr. Bldg 2, Pleasanton, CA 94588.

The Test site used by Bay Area Compliance Laboratory Corporation to collect radiated and conducted emission measurement data is located in the building at 230 Commercial Street, Sunnyvale, CA 94085.

Additionally, Bay Area Compliance Laboratory Corporation is a National Institute of Standards and Technology (NIST) accredited laboratory, under the National Voluntary Laboratory Accredited Program (NVLAP). The scope of the accreditation covers the FCC Method - 47 CFR Part 15 - Digital Devices, CISPR 22: 1997, and AS/NZS 3548: Electromagnetic Interference - Limits and Methods of Measurement of Information Technology Equipment test methods under NVLAP Lab Code 200167-0.

SYSTEM TEST CONFIGURATION

Justification

The EUT was configured for testing according to TIA/EIA 603A.

The final qualification test was performed with the EUT operating at normal mode.

Block Diagram

Please refer to Exhibit D.

Equipment Modifications

No modifications were made to the EUT.

Local Support Equipment List and Details

Manufacturer	Description	Model	Serial Number	FCC ID
Nortel	Base Station	S8000	N/A	N/A

External I/O Cabling List and Details

Cable Description	Length (M)	Port/From	To
Shielded cable	2.0	RF Output / Generator	RF Port / EUT

Power Supply Information

Manufacturer	Description	Model	Serial Number	FCC ID
Unipower	DC Power Supply (Rectifier)	RVN24/40	44027V0121	DOC

Test Setup Block Diagram

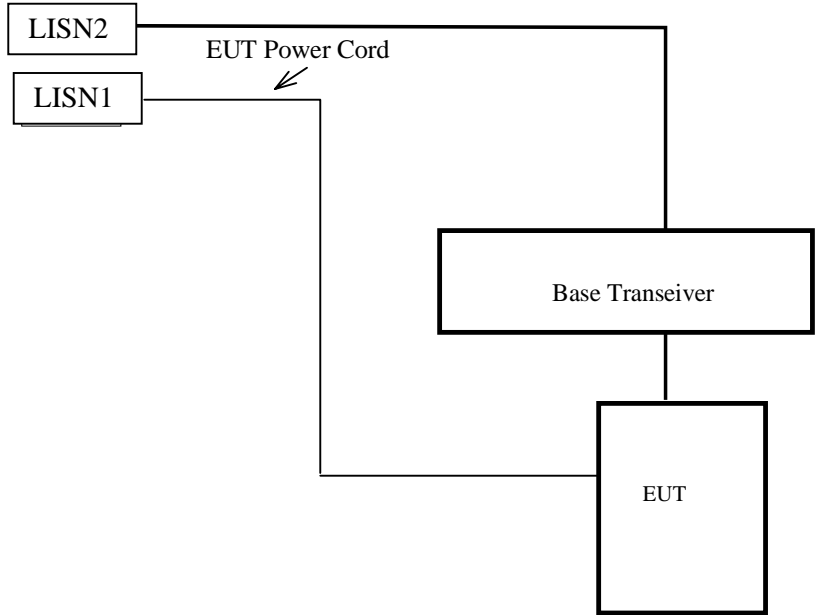

SUMMARY OF TEST RESULTS

Results reported relate only to the product tested, serial number: 10000002.

FCC RULE	DESCRIPTION OF TEST	Result
§2.1046 § 24.232	RF power output	Compliant
§ 2.1047	Modulation Characteristics	N/A
§ 2.1049 § 24.238(b)	Emission Bandwidth	Compliant
2.1051 § 24.238(a)	Spurious emissions at antenna terminals	Compliant
2.1051 § 24.238 (a)	Two-Tone Test (Spurious emissions at antenna terminals)	Compliant
2.1053 § 24.238 (a)	Radiated Spurious Emissions	Compliant
§ 2.1055 § 24.235	Frequency stability vs. temperature Frequency stability vs. voltage	N/A
§24.238	Band Edge	Compliant
IS-138A (3.4.4)	Two Tone Test	Compliant

§2.1047 - MODULATION CHARACTERISTIC

This EUT is an amplifier, not a transmitter. There is no modulating circuit in the EUT, therefore there is no modulating characteristics measurement required.

§2.1053 - SPURIOUS RADIATED EMISSIONS

Applicable Standard

Requirements: CFR 47, § 24.238 (a), on any frequency outside a licensee's frequency block. The power of any emission shall be attenuated below the transmitter power (P) by at least $43+10\lg(P)$ dB, equivalent to -13dBm .

In the event it is either impractical or impossible to make open field measurement [e.g. a broadcast transmitter installed in a building] measurement will be accepted of equipment as installed.

Test Procedure

The EUT was placed beside the base station and connected to the base station transmitter. The transmitter was RF enabled and the EUT amplified the signal into a non-radiating load. The test antenna was placed at a distance of 3 meters from the EUT. In order to identify the maximum level of emissions from the EUT, the antenna height and polarization were varied during the test, and the antenna azimuth was varied by moving the antenna around the EUT.

The frequency range up to tenth harmonic of the fundamental frequency was investigated.

The EUT was replaced with a substitution antenna, and a signal generator was connected to the substitution antenna by a non-radiating cable. The absolute levels of the spurious emissions were measured.

Spurious emissions in dB = $10 \lg(\text{TXpwr in Watts}/0.001)$ – the absolute level

Spurious attenuation limit in dB = $43 + 10 \text{Log}_{10}(\text{power out in Watts})$

Test Equipment List and Details

Manufacturer	Description	Model	Serial Number	Cal. Date
HP	Spectrum Analyzer	8568B	2601A02165	2004-07-03
HP	Amplifier	8447E	2944A10187	2003-09-23
HP	Quasi-Peak Adapter	85650A	3019A05393	2004-06-13
EMCO	Biconical Antenna	3110B	9309-1165	2003-10-11
EMCO	Log Periodic Antenna	3146	2101	2003-10-11
AH System	Horn Antenna	SAS-200/511	261	2003-08-02
HP	Spectrum Analyzer	HP8564E	3943A01781	2003-08-01

* **Statement of Traceability: BAEL Corp.** certifies that all calibrations have been performed in accordance to NVLAP requirements, traceable to the NIST.

Environmental Conditions

Temperature:	28.9° C
Relative Humidity:	28%
ATM Pressure:	1013.9 mbar

The testing was performed by Ming Jin on 2004-07-14.

Test Result

Data for GSM1900

Low Frequency: -21.1 dB at 3860.8 MHz

Middle Frequency: -21.0 dB at 3920 MHz

High Frequency: -21.2 dB at 3979.2 MHz

Indicated		EUT			Substitution		Generator			Standard	
Frequency	Ampl.	Table	Test Antenna		Frequency	Level	Antenna	Cable	Absolute	FCC	FCC
MHz	dBuV/m	Angle	Height	Polar	MHz	dBm	Gain	Loss	Level	Limit	Margin
		Degree	Meter	H/V			Corrected	dB	dBm	dBm	dB
Low Channel											
1930.4											
1930.4											
3860.8	44.82	30	1.2	v	3860.8	-41.7	8.8	1.2	-34.1	-13	-21.1
3860.8	42.71	0	1.5	h	3860.8	-43.5	8.8	1.2	-35.9	-13	-22.9
5791.2	33.75	180	1.6	v	5791.2	-52.5	9.9	1.5	-44.1	-13	-31.1
5791.2	31.46	270	1.2	h	5791.2	-54.3	9.9	1.5	-45.9	-13	-32.9
7721.6	29.68	30	1.5	v	7721.6	-56.9	10.3	1.8	-48.4	-13	-35.4
7721.6	28.75	0	1.5	h	7721.6	-57.7	10.3	1.8	-49.2	-13	-36.2
MIDDLE CHANNEL											
1960											
1960											
3920	44.96	270	1.5	v	3920	-41.6	8.8	1.2	-34	-13	-21.0
3920	42.83	30	1.2	h	3920	-43.3	8.8	1.2	-35.7	-13	-22.7
5880	33.91	0	1.5	v	5880	-52.3	9.9	1.5	-43.9	-13	-30.9
5880	31.52	180	1.6	h	5880	-54.2	9.9	1.5	-45.8	-13	-32.8
7840	29.73	30	1.5	v	7840	-56.8	10.3	1.8	-48.3	-13	-35.3
7840	28.82	90	1.5	h	7840	-57.5	10.3	1.8	-49	-13	-36.0
HIGH CHANNEL											
1989.6											
1989.6											
3979.2	44.73	0	1.5	v	3979.2	-41.8	8.8	1.2	-34.2	-13	-21.2
3979.2	42.65	30	1.5	h	3979.2	-43.6	8.8	1.2	-36	-13	-23.0
5968.8	33.54	270	1.2	v	5968.8	-52.8	9.9	1.5	-44.4	-13	-31.4
5968.8	31.37	180	1.2	h	5968.8	-54.5	9.9	1.5	-46.1	-13	-33.1
7958.4	29.55	270	1.5	v	7958.4	-57.1	10.3	1.8	-48.6	-13	-35.6
7958.4	28.62	0	1.2	h	7958.4	-57.8	10.3	1.8	-49.3	-13	-36.3

Data for EDGE1900

Low Frequency: -21.0 dB at 3860.8 MHz
 Middle Frequency: -20.9 dB at 3920 MHz
 High Frequency: -21.2 dB at 3979.2 MHz

Indicated		EUT			Substitution		Generator			Standard	
Frequency	Ampl.	Table	Test Antenna		Frequency	Level	Antenna	Cable	Absolute	FCC	FCC
MHz	dBuV/m	Angle	Height	Polar	MHz	dBm	Gain	Loss	Level	Limit	Margin
		Degree	Meter	H/V			Corrected	dB	dBm	dBm	dB
Low Channel											
1930.4											
1930.4											
3860.8	44.91	30	1.2	v	3860.8	-41.6	8.8	1.2	-34	-13	-21.0
3860.8	42.83	0	1.5	h	3860.8	-43.4	8.8	1.2	-35.8	-13	-22.8
5791.2	33.79	180	1.6	v	5791.2	-52.5	9.9	1.5	-44.1	-13	-31.1
5791.2	31.52	270	1.2	h	5791.2	-54.2	9.9	1.5	-45.8	-13	-32.8
7721.6	29.74	30	1.5	v	7721.6	-56.8	10.3	1.8	-48.3	-13	-35.3
7721.6	28.85	0	1.5	h	7721.6	-57.6	10.3	1.8	-49.1	-13	-36.1
MIDDLE CHANNEL											
1960											
1960											
3920	45.01	270	1.5	v	3920	-41.5	8.8	1.2	-33.9	-13	-20.9
3920	42.88	30	1.2	h	3920	-43.3	8.8	1.2	-35.7	-13	-22.7
5880	33.96	0	1.5	v	5880	-52.2	9.9	1.5	-43.8	-13	-30.8
5880	31.58	180	1.6	h	5880	-54.1	9.9	1.5	-45.7	-13	-32.7
7840	29.84	30	1.5	v	7840	-56.7	10.3	1.8	-48.2	-13	-35.2
7840	28.91	90	1.5	h	7840	-57.4	10.3	1.8	-48.9	-13	-35.9
HIGH CHANNEL											
1989.6											
1989.6											
3979.2	44.79	0	1.5	v	3979.2	-41.8	8.8	1.2	-34.2	-13	-21.2
3979.2	42.71	30	1.5	h	3979.2	-43.7	8.8	1.2	-36.1	-13	-23.1
5968.8	33.62	270	1.2	v	5968.8	-52.9	9.9	1.5	-44.5	-13	-31.5
5968.8	31.41	180	1.2	h	5968.8	-54.4	9.9	1.5	-46	-13	-33.0
7958.4	29.61	270	1.5	v	7958.4	-57.2	10.3	1.8	-48.7	-13	-35.7
7958.4	28.67	0	1.2	h	7958.4	-57.8	10.3	1.8	-49.3	-13	-36.3

§2.1046, & §24.232 - RF POWER OUTPUT

Applicable Standard

According to FCC §2.1046 and §24.232 (a), in no case may the peak output power of a base station transmitter exceed 100 watt.

Test Procedure

The GSM and EDGE signals were provided by the Nortel S8000 Base Transceiver Station (BTS). The EUT output was connected to a calibrated coaxial attenuator (50 Ohm), which was then connected to an Agilent Power Sensor. The EUT output power was calculated by adding the value observed on the Power Meter (dBm) with the measurement loss of the attenuator.

The test was performed at three frequencies (GSM channels 513, 661, and 809) with the BTS power set to 39dBm.

Test Equipment List and Details

Manufacturer	Description	Model	Serial Number	Cal. Date
Agilent	Power Meter	E4419B	MY41291511	2004-04-29
Weinschel	Attenuator	MS015	58633	N/A

* **Statement of Traceability: BAEL Corp.** certifies that all calibrations have been performed in accordance to NVLAP requirements, traceable to the NIST.

Environmental Conditions

Temperature:	28.9° C
Relative Humidity:	28%
ATM Pressure:	1013.9 mbar

The testing was performed by Ming Jin on 2004-07-14.

Test Results

Mode	Signal	Channel Frequency MHz	Carrier RF Input Power dBm	Per Carrier RF Output Power dBm	Two Carrier Composite RF Output Power dBm
Combined	GSM	Low : 1930.4	39	45.83	49.94
		Mid : 1960.0	39	45.92	49.98
		High :1989.6	39	45.44	49.75
	EDGE	Low : 1930.4	39	45.87	48.97
		Mid : 1960.0	39	45.91	48.98
		High :1989.6	39	45.34	48.68
Isolated	GSM	Low : 1930.4	39	49.28	N/A
		Mid : 1960.0	39	49.41	N/A
		High :1989.6	39	48.91	N/A
	EDGE	Low : 1930.4	39	49.38	N/A
		Mid : 1960.0	39	49.49	N/A
		High :1989.6	39	49.13	N/A

§2.1049, & §24.238(b) - EMISSION BANDWIDTH

Applicable Standards

According to FCC §2.1049 and §24.238 (b), the emission bandwidth is defined as the width of the signal between two points, one below the carrier center frequency and one above the carrier center frequency, outside of which all emissions are attenuated at least 26dB below the transmitter power.

Test Procedure

The EUT output was connected to the input of the Spectrum Analyzer through a calibrated attenuator.

The resolution bandwidth of the Spectrum Analyzer was set to 30Khz.

Test Equipment

Manufacturer	Description	Model	Serial Number	Cal. Date
HP	Spectrum Analyzer	HP8564E	3943A01781	2003-08-01
HP	Plotter	HP7470A	2541A49659	Not Required
Weinschel	Attenuator	MS015	58633	N/A

* **Statement of Traceability: BA CL Corp.** certifies that all calibrations have been performed in accordance to NVLAP requirements, traceable to the NIST.

Environmental Conditions

Temperature:	28.9° C
Relative Humidity:	28%
ATM Pressure:	1013.9 mbar

The testing was performed by Ming Jin on 2004-07-14.

Test Results

Mode	Channel	Type	Measurement (KHz)	Result
GSM	Low	Occupied Bandwidth	248.3	Compliant
		26dB Bandwidth	327.0	Compliant
	Middle	Occupied Bandwidth	250.0	Compliant
		26dB Bandwidth	328.0	Compliant
	High	Occupied Bandwidth	251.7	Compliant
		26dB Bandwidth	330.0	Compliant
EDGE	Low	Occupied Bandwidth	255.0	Compliant
		26dB Bandwidth	327.0	Compliant
	Middle	Occupied Bandwidth	253.3	Compliant
		26dB Bandwidth	328.0	Compliant
	High	Occupied Bandwidth	251.7	Compliant
		26dB Bandwidth	327.0	Compliant

Please refer to plots hereinafter.

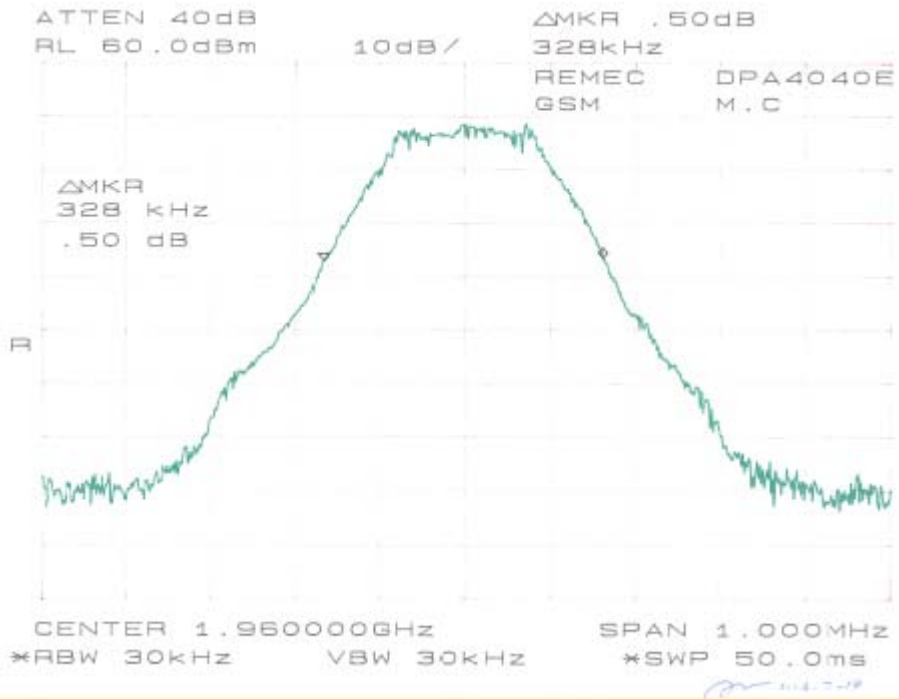
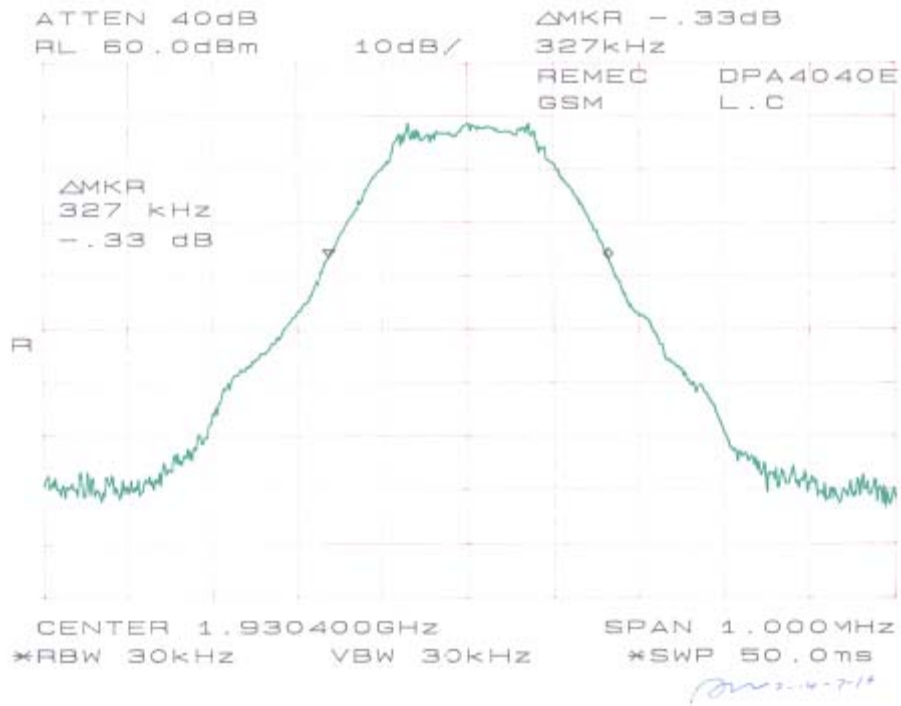

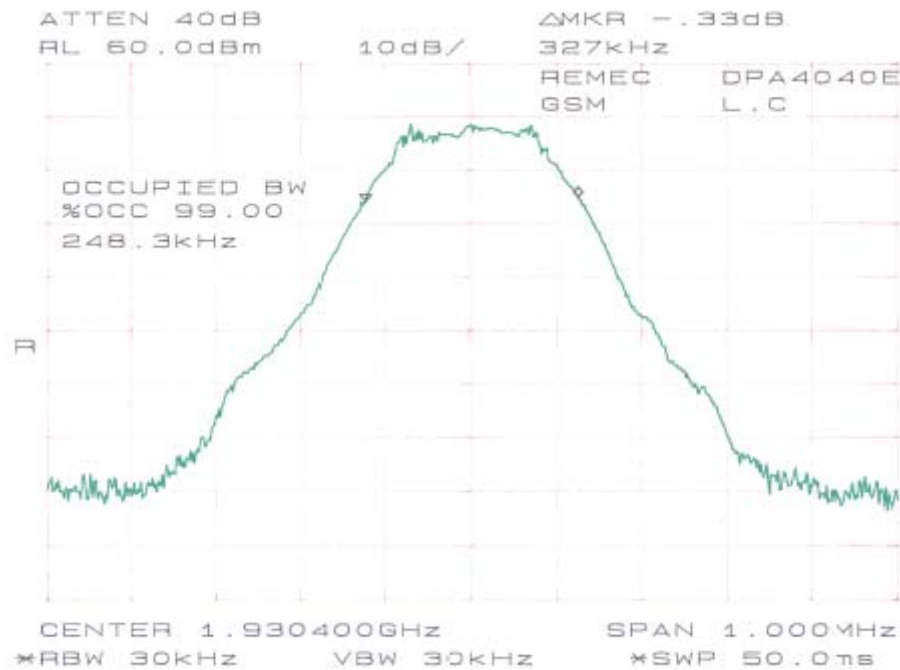
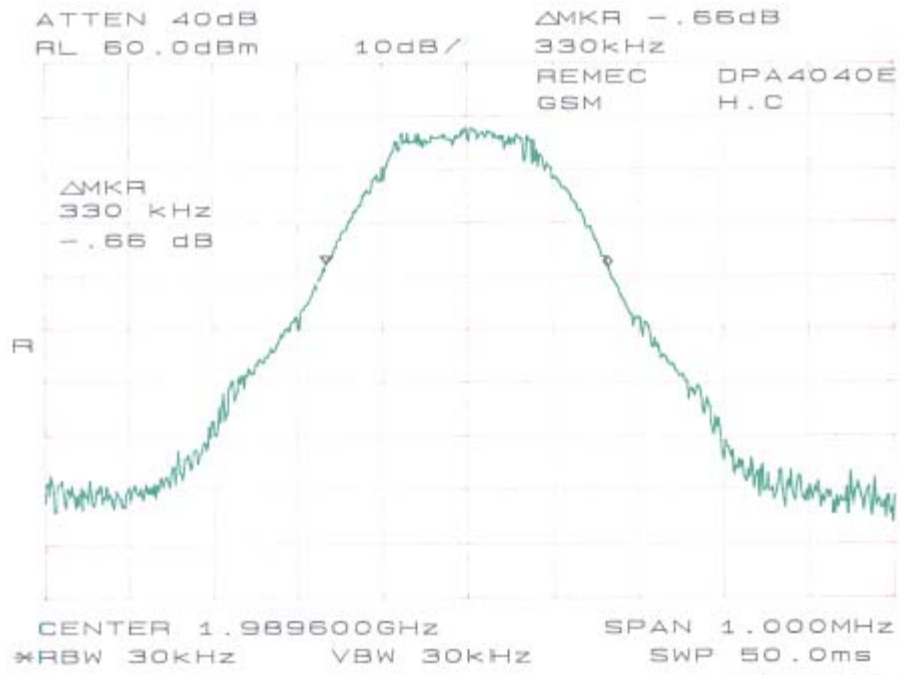

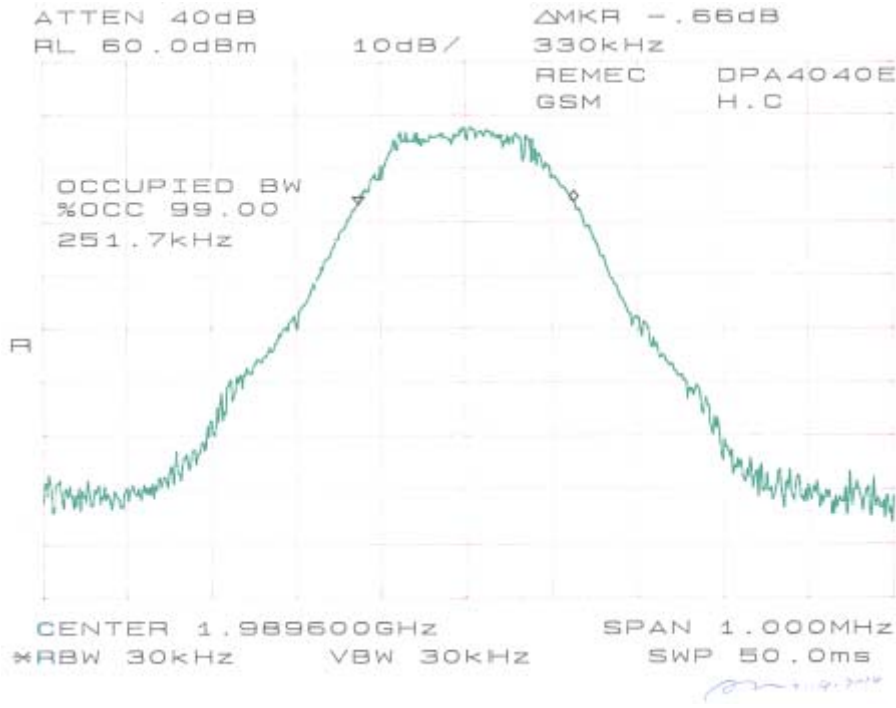
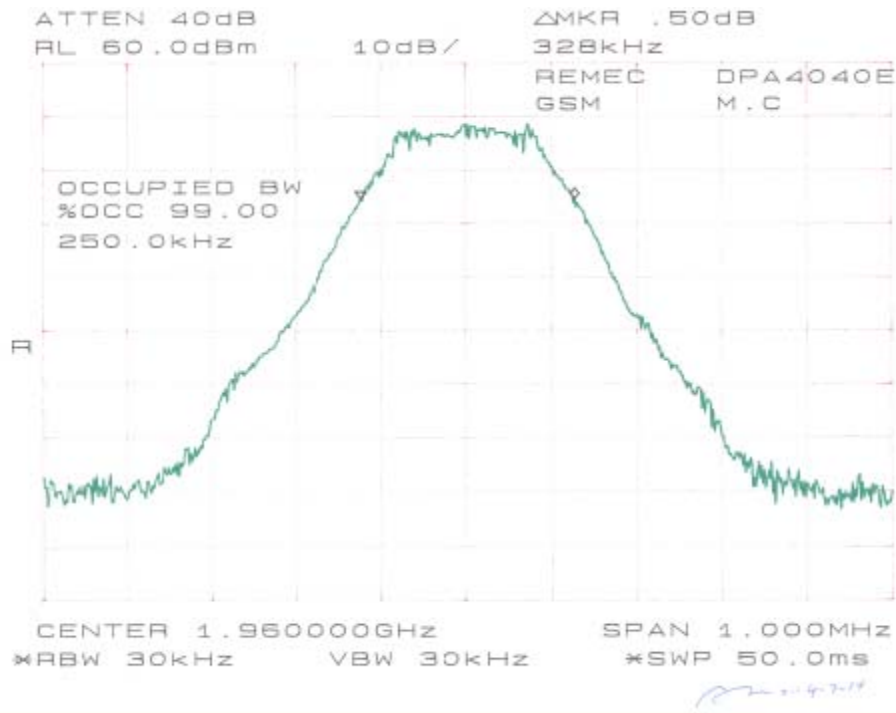

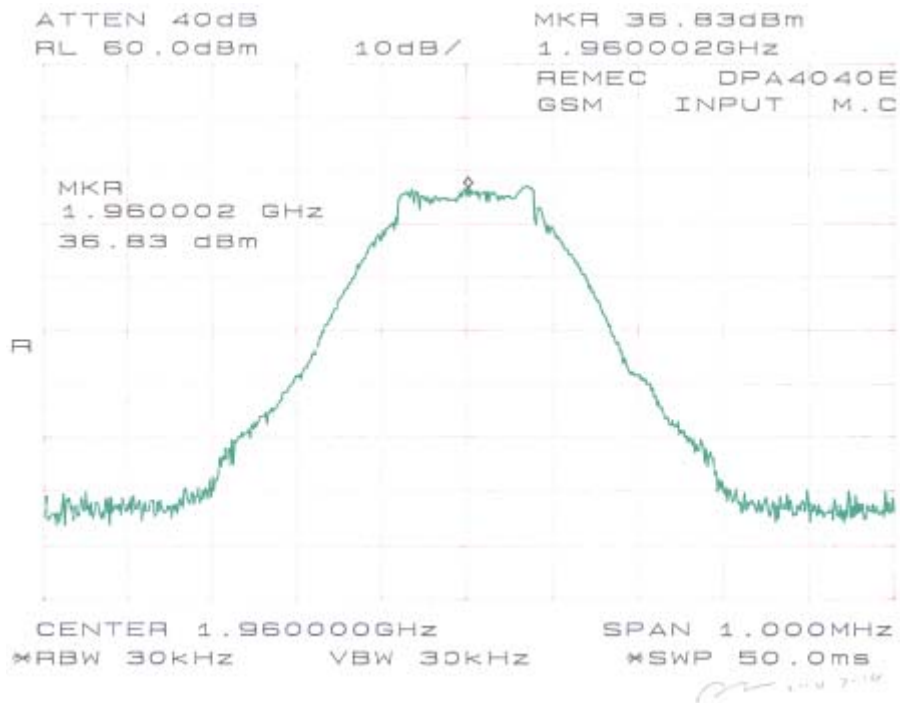
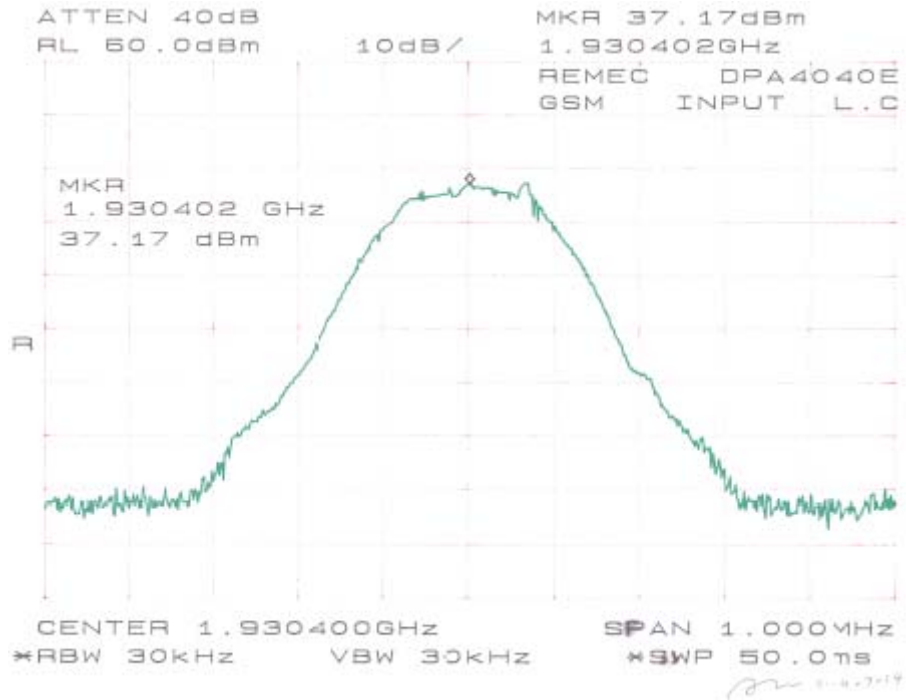

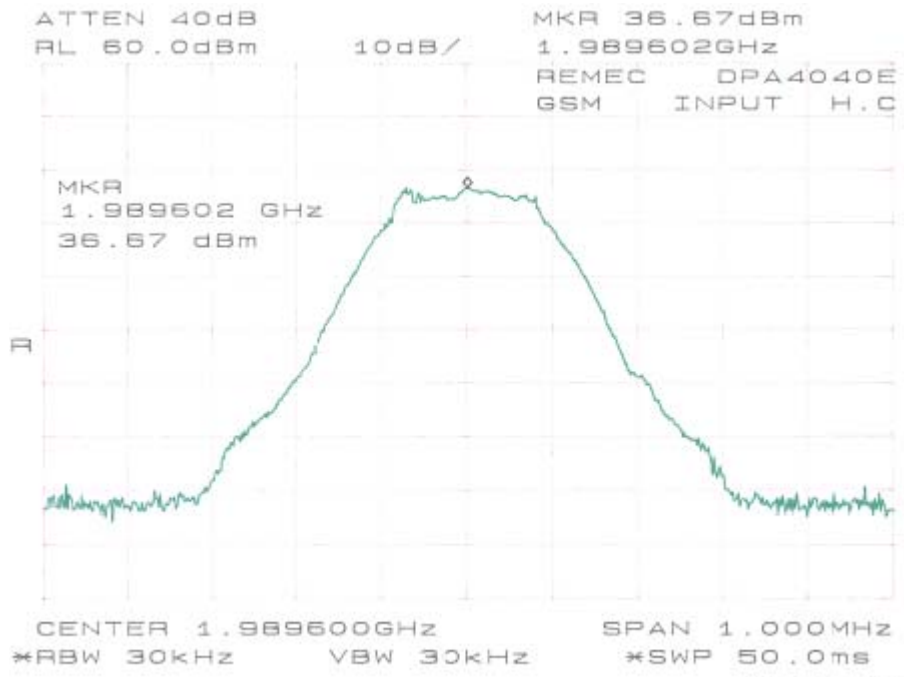

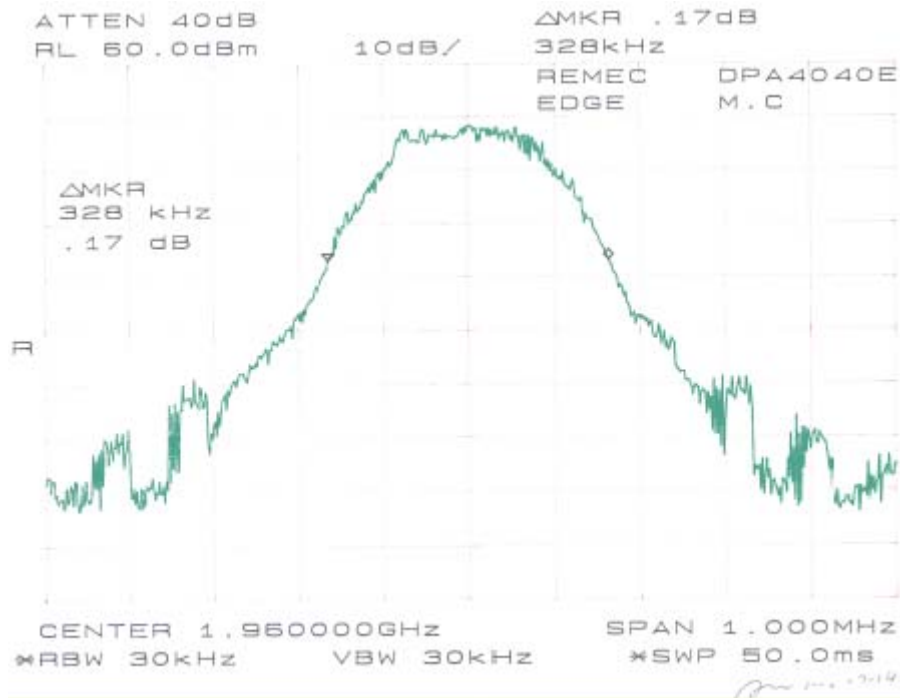
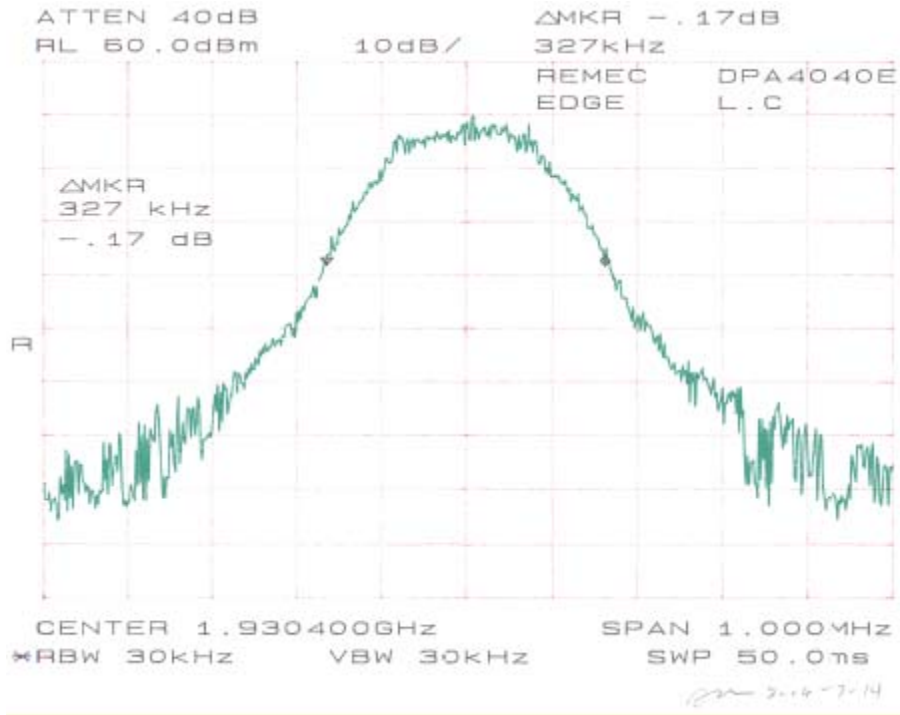

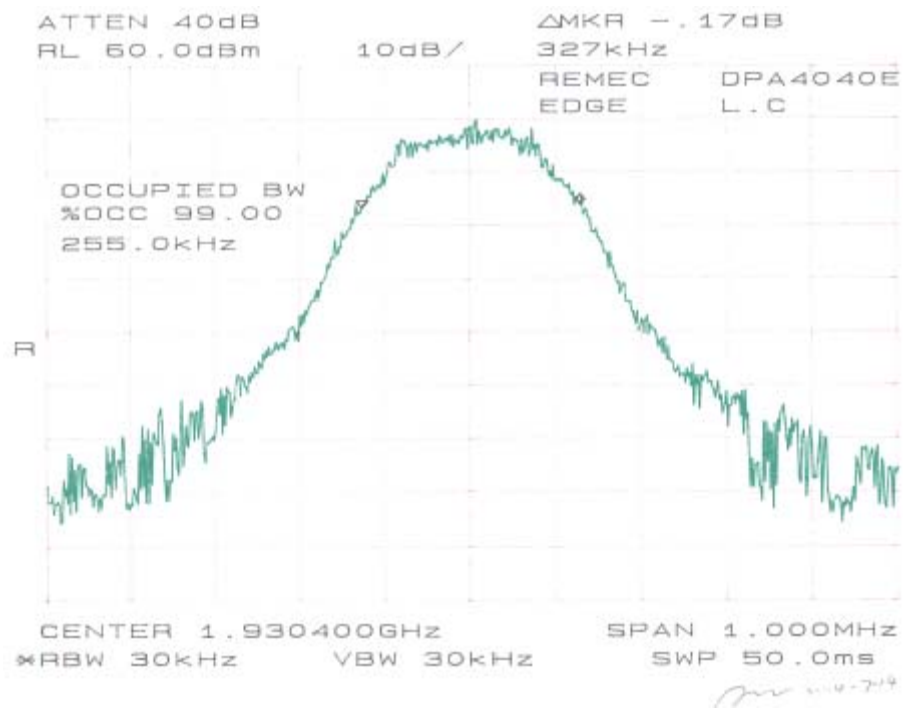
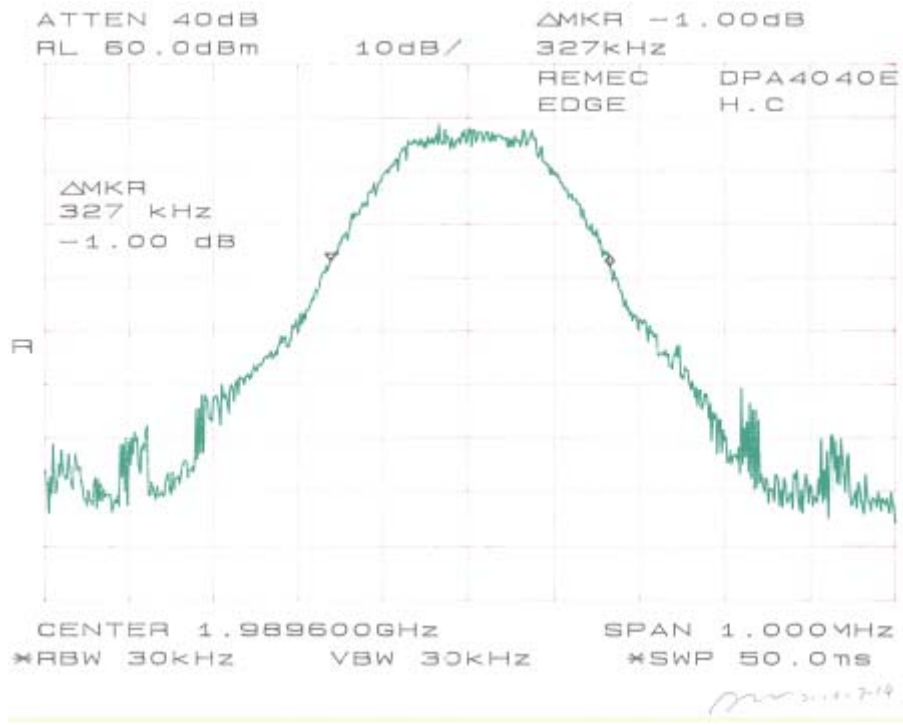

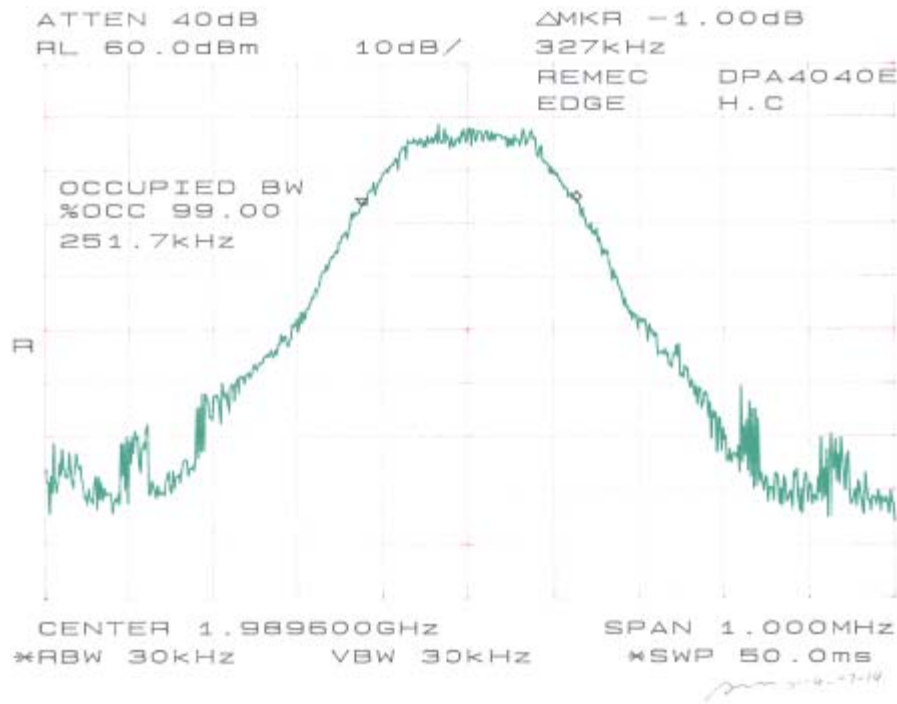
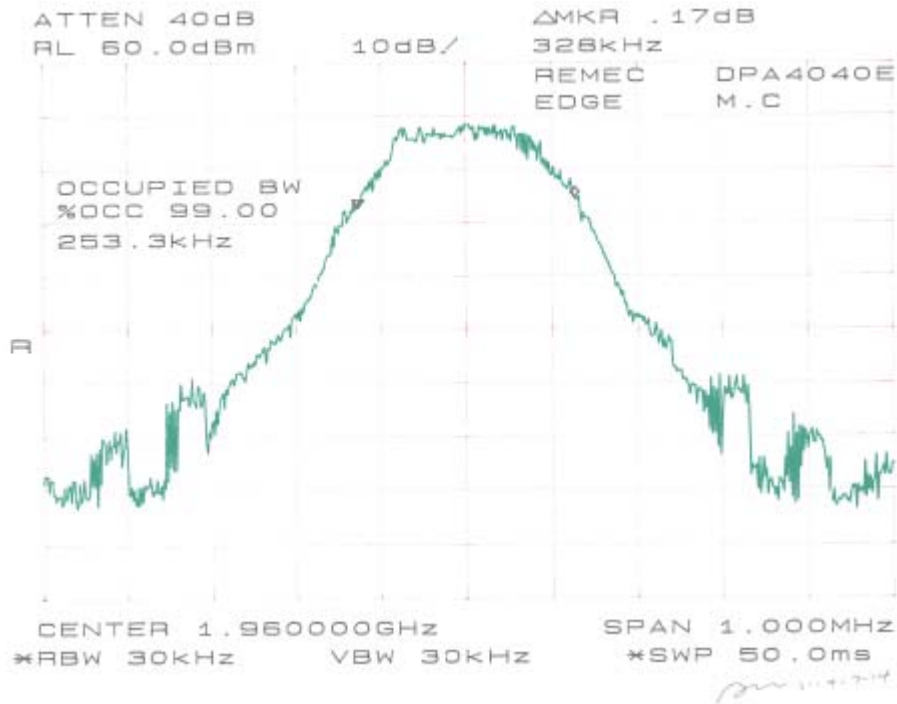

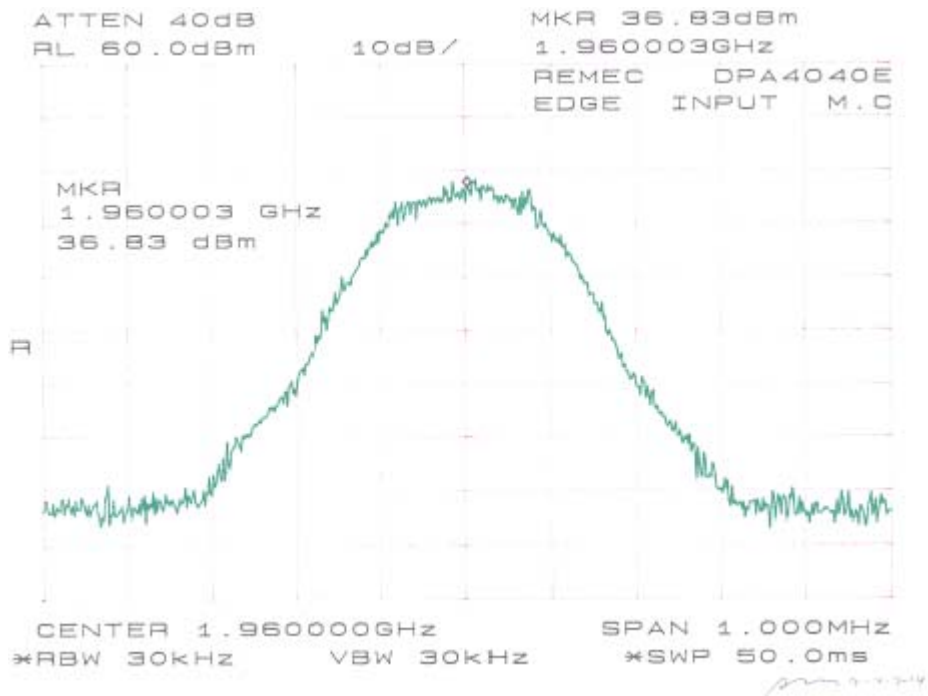
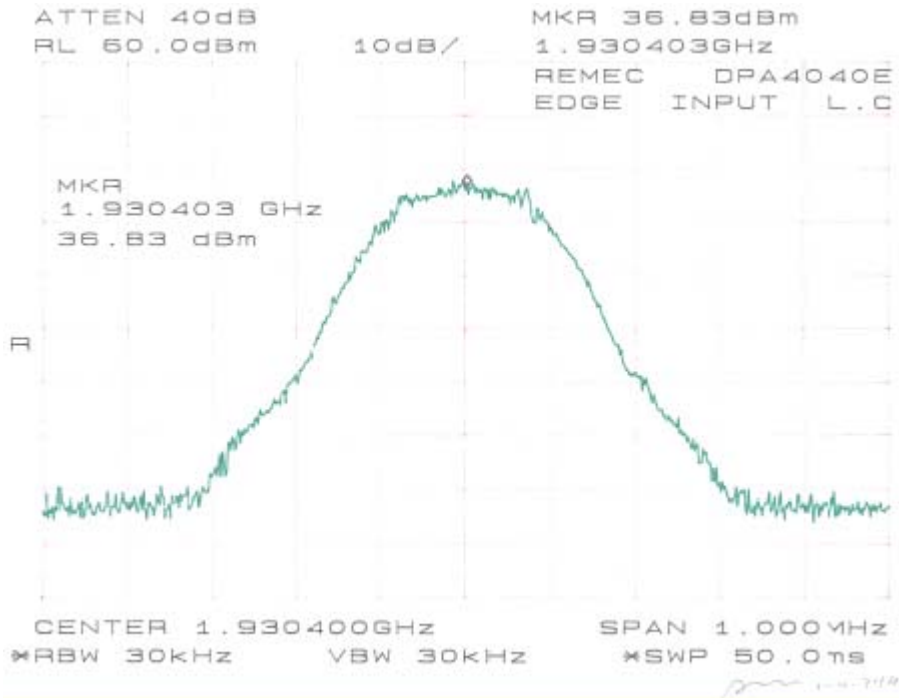

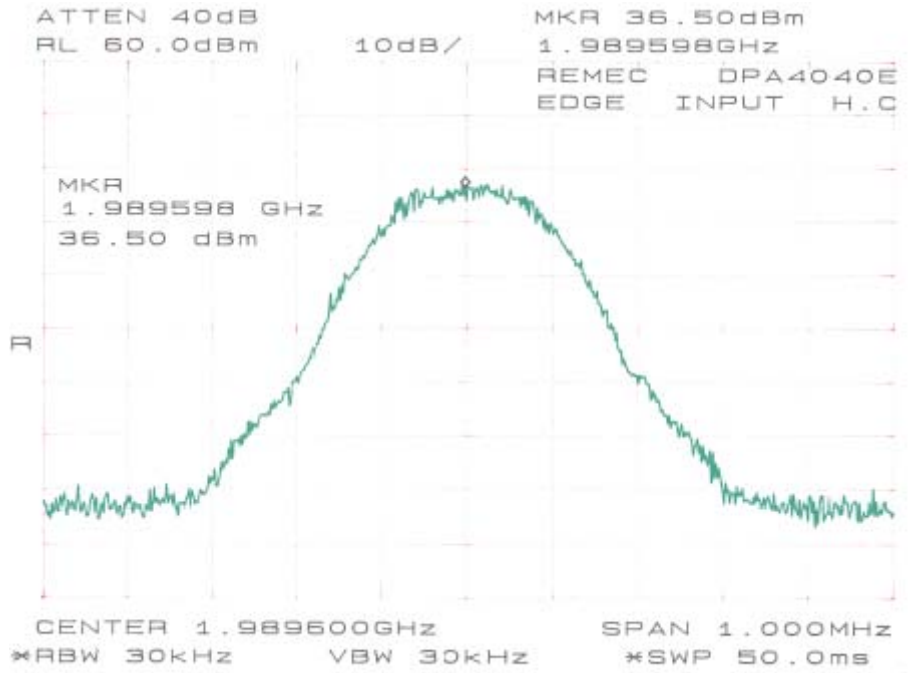

§2.1051, & §24.238(a) - SPURIOUS EMISSIONS AT ANTENNA TERMINALS

Applicable Standard

Requirements: CFR 47, § 2.1051 & §24.238(a).

The spectrum was to be investigated to the tenth harmonics of the highest fundamental frequency as specified in § 2.1057.

Test Procedure

The EUT output was connected to the input of the Spectrum Analyzer through a calibrated attenuator.

The resolution bandwidth of the Spectrum Analyzer was set to 30kHz, and the resulting data was plotted to show any out-of-band emissions up to the 10th harmonic.

Test Equipment List and Details

Manufacturer	Description	Model	Serial Number	Cal. Date
HP	Spectrum Analyzer	HP8564E	3943A01781	2003-08-01
HP	Plotter	HP7470A	2541A49659	Not Required
Weinschel	Attenuator	MS015	58633	N/A

* **Statement of Traceability:** BACL Corp. certifies that all calibrations have been performed in accordance to NVLAP requirements, traceable to the NIST.

Environmental Conditions

Temperature:	28.9° C
Relative Humidity:	28%
ATM Pressure:	1013.9 mbar

The testing was performed by Ming Jin on 2004-07-14.

Test Results

Please refer to the hereinafter plots.

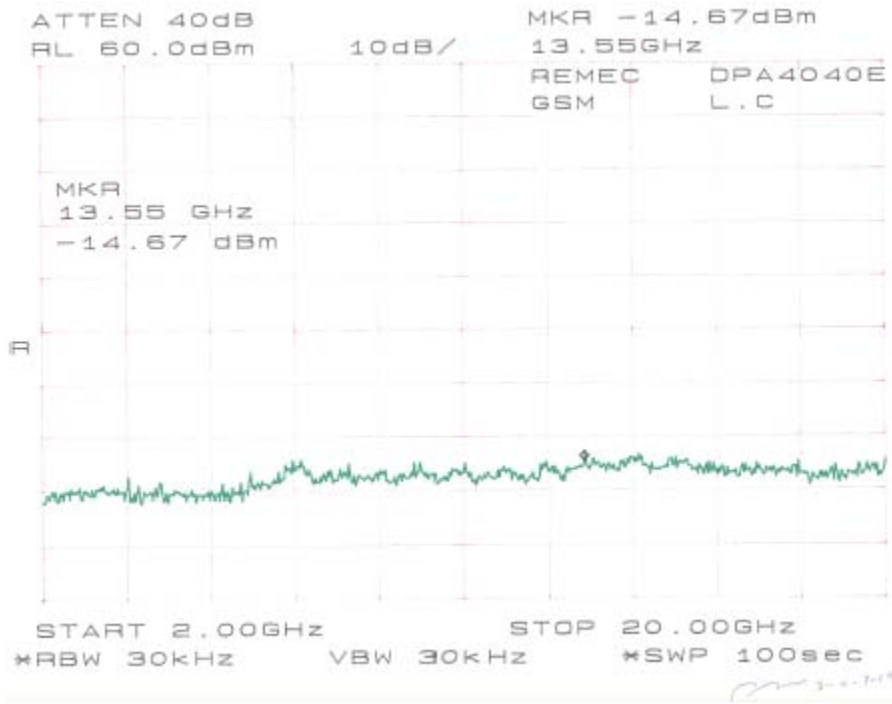
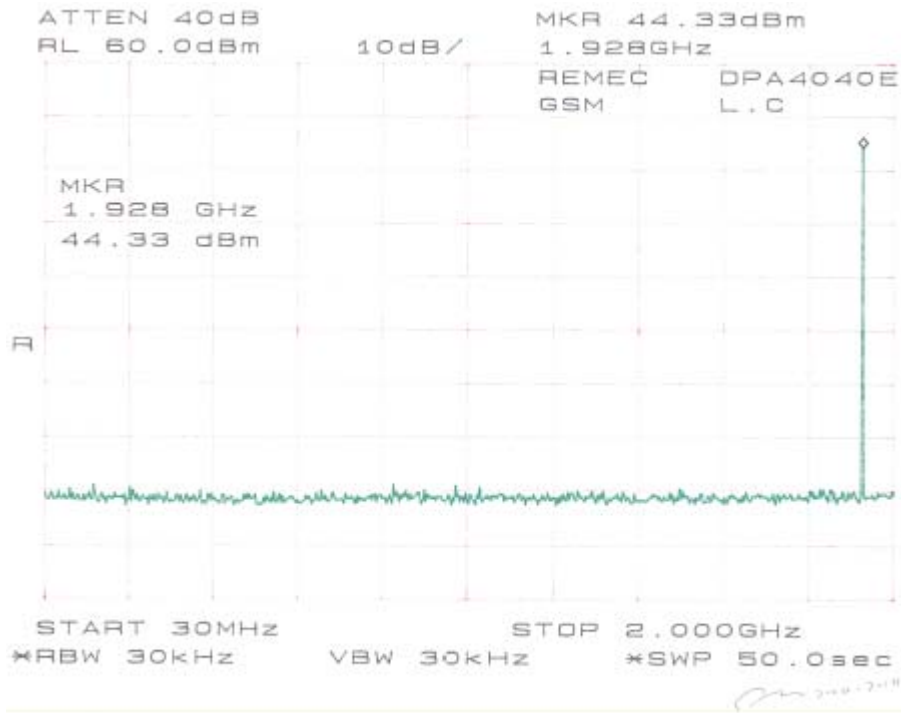

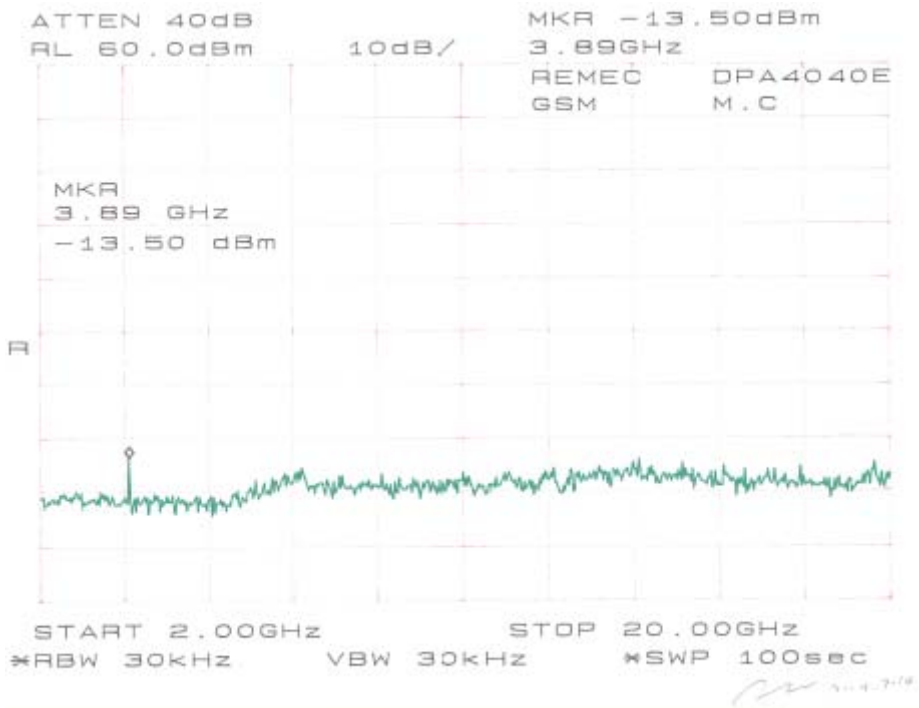
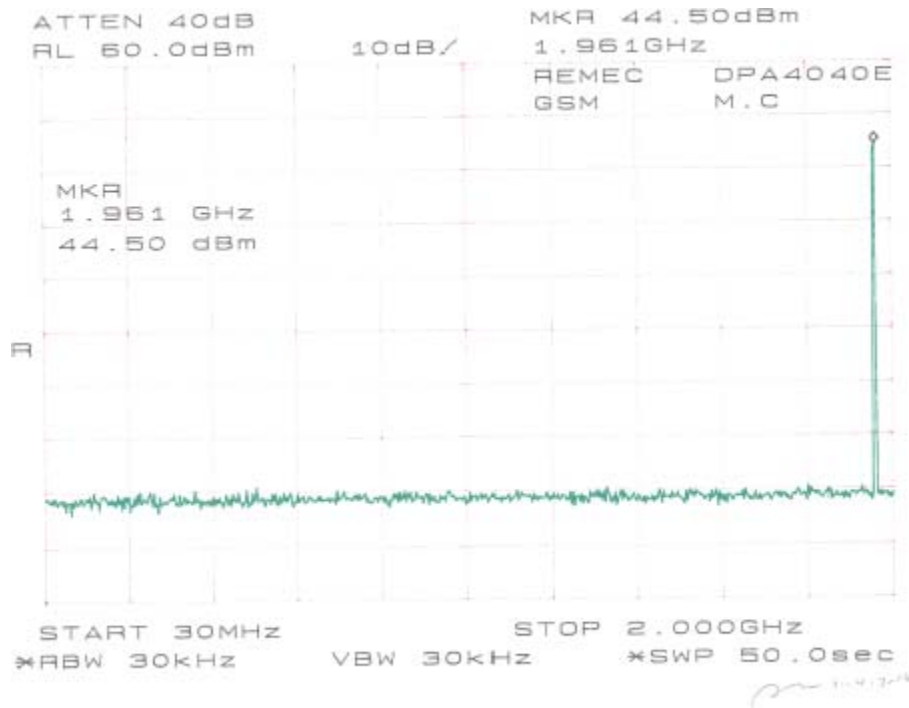

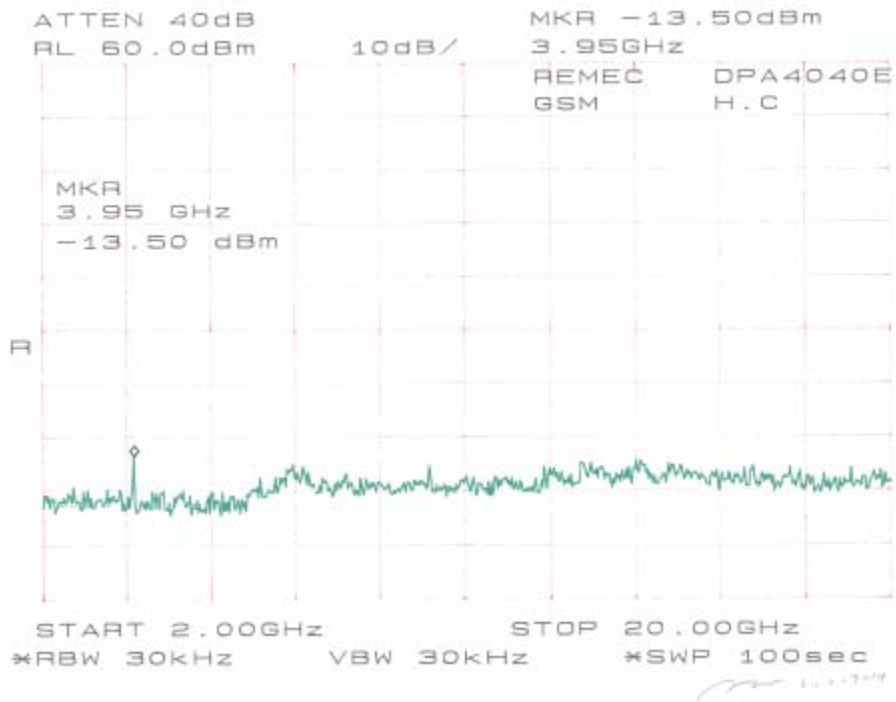
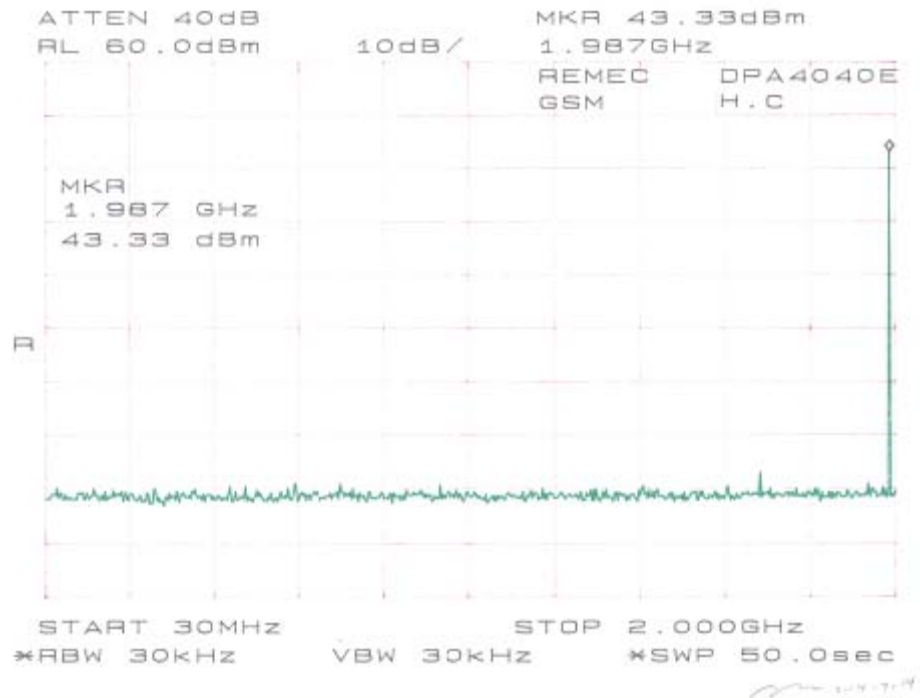

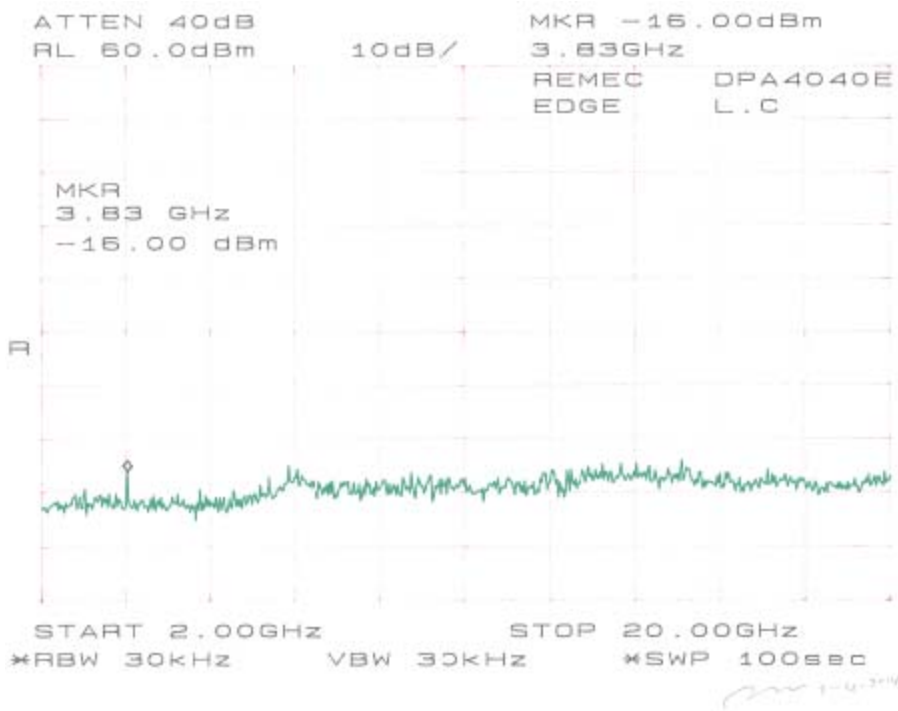
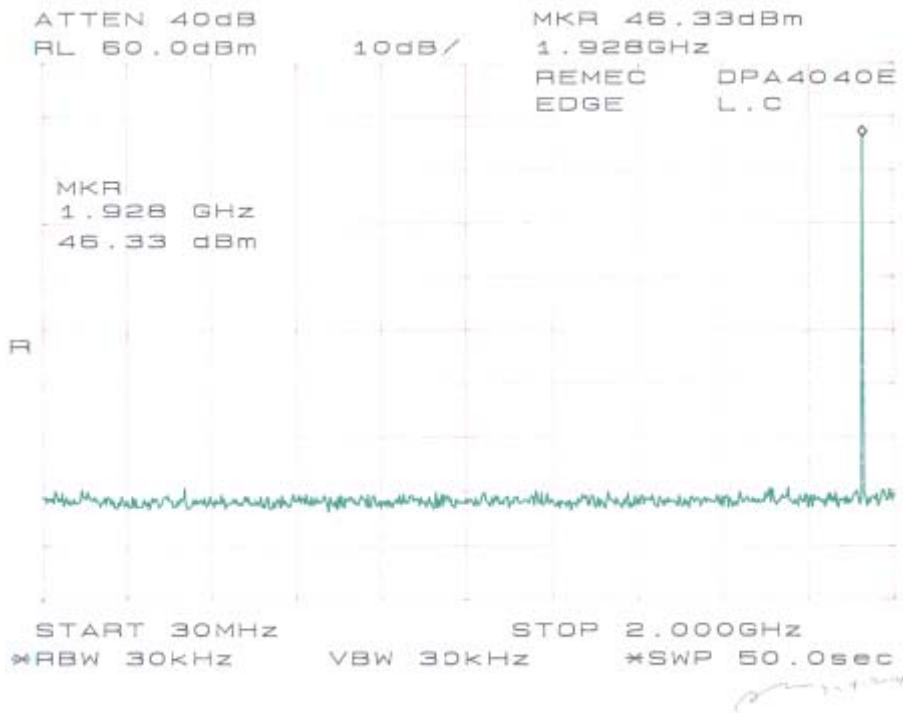

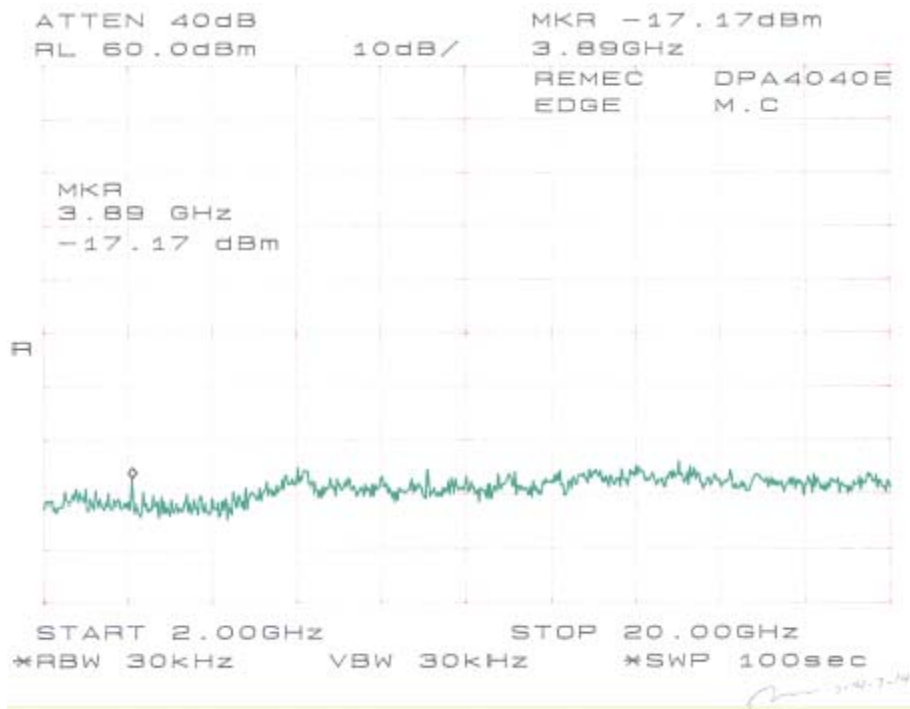
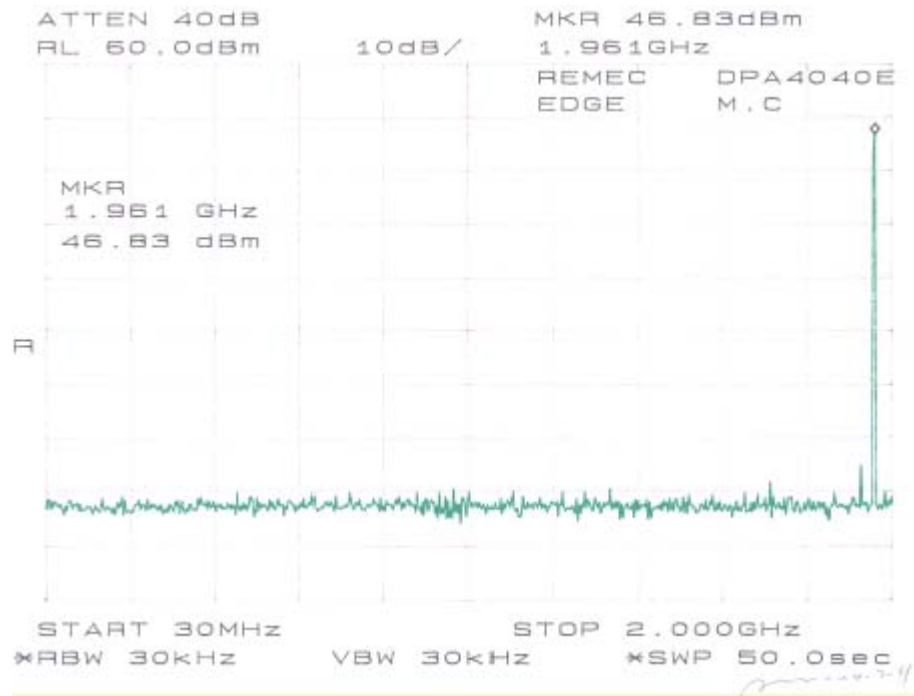

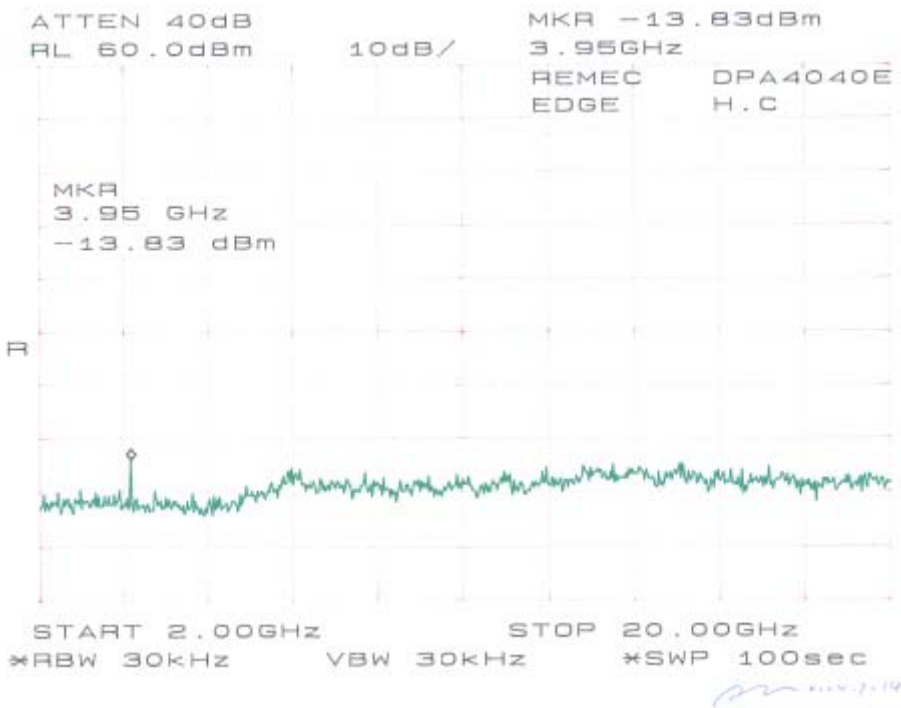
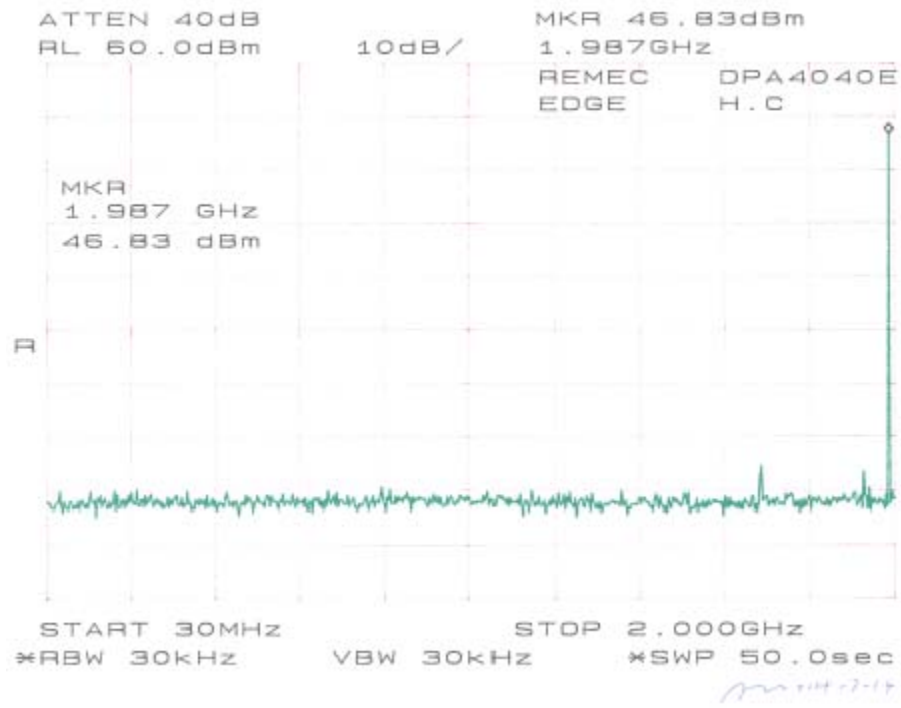

§2.1055 (a), §2.1055 (d), & §24.235 - FREQUENCY STABILITY

This EUT is an amplifier, not a transmitter. There is no oscillator circuit in the EUT, therefore there is no frequency stability measurement required.

§24.238 – BAND EDGE

Applicable Standard

According to §24.238, the power of any emission outside of the authorized operating frequency ranges must be attenuated below the transmitting power (P) by a factor of at least $43 + 10 \log(P)$ dB.

Test Procedure

The EUT output was connected to the input of the Spectrum Analyzer through a calibrated attenuator.

The resolution bandwidth of the Spectrum Analyzer was set to 30kHz, and the center frequency was set to the band edge frequency.

Test Equipment List and Details

Manufacturer	Description	Model	Serial Number	Cal. Date
HP	Spectrum Analyzer	HP8564E	3943A01781	2003-08-01
HP	Plotter	HP7470A	2541A49659	Not Required
Weinschel	Attenuator	MS015	58633	N/A

* **Statement of Traceability: BACL Corp.** certifies that all calibrations have been performed in accordance to NVLAP requirements, traceable to the NIST.

Environmental Conditions

Temperature:	28.9° C
Relative Humidity:	28%
ATM Pressure:	1013.9 mbar

The testing was performed by Ming Jin on 2004-07-14.

Test Results

Please refer to the following plots.

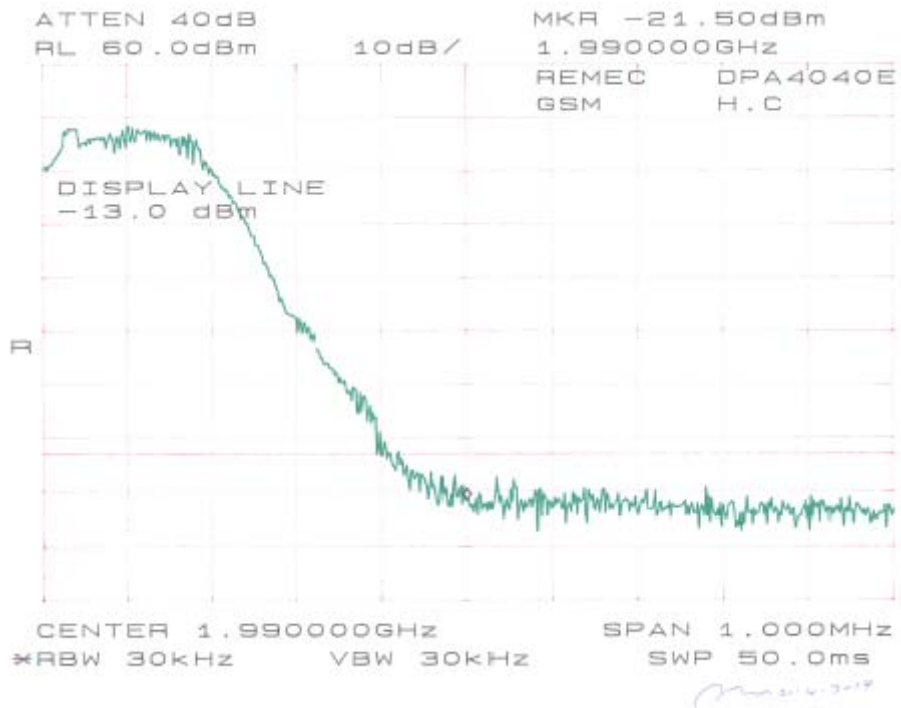
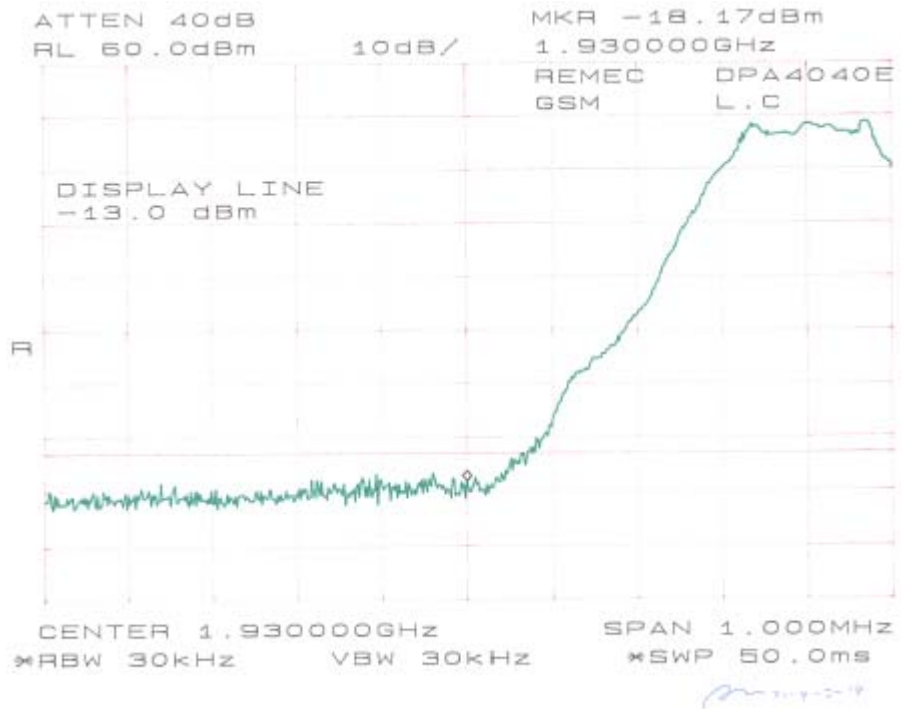

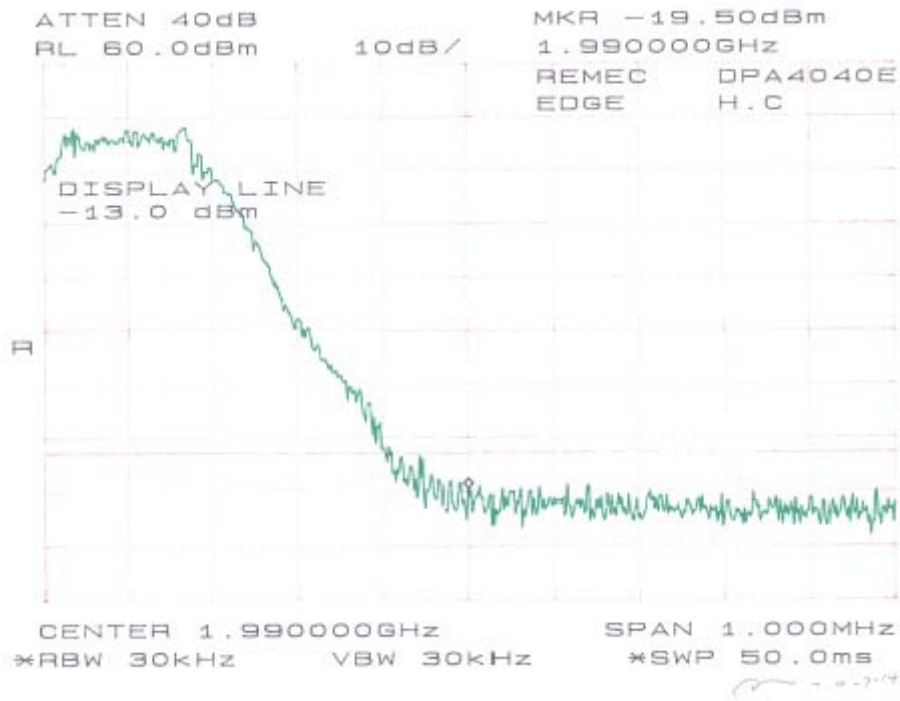
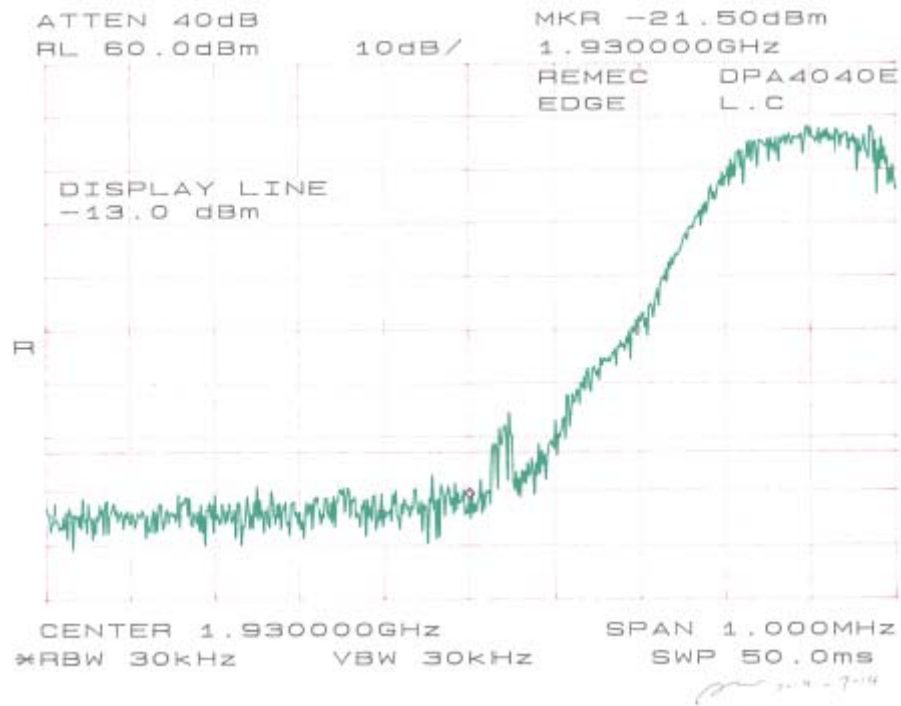

TWO-TONE TEST

Applicable Standards

According to IS-138A (3.4.4), Intermodulation products must be attenuated below the rated power of the EUT by at least $43 + 10\log(P)$, equivalent to -13 dBm.

Test Procedure

The RF output of the EUT was connected to a spectrum analyzer through appropriate attenuation. The resolution bandwidth of the spectrum analyzer was set at 1 MHz. Sufficient scans were taken to show any out of band emissions up to 10th harmonic. Two input signals are equal in level (and can be raised equally), were send to the EUT.

Test Equipment

Hewlett Packard HP8566B Spectrum Analyzer
Hewlett Packard HP 7470A Plotter
Rohde & Schwarz SMIQ03B Signal Generator
Rohde & Schwarz AMIQ I/Q Modulation Generator

Test Results

Please refer to plots hereinafter.

