



Zebra® R110X™/R170X™  
High-Performance Printers

---

# User Guide



© 2004 ZIH Corp.

The copyrights in this manual and the label print engine described therein are owned by Zebra Technologies Corporation. Unauthorized reproduction of this manual or the software in the label print engine may result in imprisonment of up to one year and fines of up to \$10,000 (17 U.S.C.506). Copyright violators may be subject to civil liability.

This product may contain ZPL<sup>®</sup>, ZPL II<sup>®</sup>, and ZebraLink(tm) programs; Element Energy Equalizer<sup>®</sup> Circuit; E3<sup>®</sup>; and AGFA fonts. Software © ZIH Corp. All rights reserved worldwide.

ZebraLink and all product names and numbers are trademarks, and Zebra, the Zebra logo, ZPL, ZPL II, Element Energy Equalizer Circuit, and E3 Circuit are registered trademarks of ZIH Corp. All rights reserved worldwide.

CG Triumvirate is a trademark of AGFA Monotype Corporation. All rights reserved worldwide. CG Triumvirate<sup>™</sup> font © AGFA Monotype Corporation. Intellifont<sup>®</sup> portion © AGFA Monotype Corporation. All rights reserved worldwide. UFST is a registered trademark of AGFA Monotype Corporation. All rights reserved worldwide.

All other brand names, product names, or trademarks belong to their respective holders.

**Customer Order # 23063L-003**

**Manufacturer Part # 23063L-003 Rev. 2**

# DECLARATION OF CONFORMITY

I have determined that the Zebra printers identified as the

*XiIIIPlus* Series  
90*XiIIIPlus*, 96*XiIIIPlus*, 110*XiIIIPlus*,  
140*XiIIIPlus*, 170*XiIIIPlus*, 220*XiIIIPlus*

manufactured by:

**Zebra Technologies**  
333 Corporate Woods Parkway  
Vernon Hills, Illinois 60061-3109 U.S.A.

Have been shown to comply with the applicable technical standards of the FCC

For Home, Office, Commercial, and industrial use

If no unauthorized changed is made in the equipment,  
and if the equipment is properly maintained and operated.

  
\_\_\_\_\_



---

# Contents



<b>Preface</b> .....	<b>ix</b>
Contacts .....	x
Support .....	x
Document Conventions .....	xi
Related Documents .....	xii
<b>1 • Introduction</b> .....	<b>1</b>
Exterior View .....	2
Front Panel .....	3
Front Panel Buttons .....	4
Front Panel Lights .....	5
Printer Components .....	6
<b>2 • Printer Setup</b> .....	<b>7</b>
Before You Begin .....	8
Unpack and Inspect the Printer .....	9
Report Shipping Damage .....	9
Store or Reship the Printer .....	9
Select a Site for the Printer .....	10
Select a Surface .....	10
Provide Proper Operating Conditions .....	10
Allow Proper Space .....	10
Provide a Data Source .....	10
Connect the Printer to a Power Source .....	11
Power Cord Specifications .....	11
Select a Communication Interface .....	12
Data Cable Requirements .....	13
Types of Media .....	14

Ribbon . . . . .	16
When to Use Ribbon . . . . .	16
Coated Side of Ribbon . . . . .	16
<b>3 • Printer Operation . . . . .</b>	<b>19</b>
Loading the Media . . . . .	20
Load Roll Media . . . . .	21
Load Fanfold Media . . . . .	24
Loading Ribbon . . . . .	26
Create a Ribbon Leader . . . . .	27
Load Ribbon . . . . .	27
Remove Used Ribbon . . . . .	31
Print a Printer Configuration Label . . . . .	32
Print a Network Configuration Label . . . . .	34
Calibrate the Printer . . . . .	35
Adjust Media Sensors . . . . .	37
Adjust Printhead Pressure and Toggle Position . . . . .	39
Toggle Position Adjustment . . . . .	39
Printhead Pressure Adjustment . . . . .	40
<b>4 • Front Panel Controls . . . . .</b>	<b>41</b>
Overview . . . . .	42
Enter Setup Mode . . . . .	42
Exit Setup Mode . . . . .	42
Password-Protected Parameters . . . . .	43
Default Password Value . . . . .	43
Disable the Password Protection Feature . . . . .	43
Front Panel LCD . . . . .	44
Standard LCD Displays . . . . .	44
ZebraNet® Wired and Wireless Print Server LCD Displays . . . . .	60
RFID LCD Displays . . . . .	62
<b>5 • RFID Guidelines . . . . .</b>	<b>65</b>
Overview . . . . .	66
Transponder Placement . . . . .	66
ZPL Commands for RFID Applications . . . . .	66
Electronic Product Code (EPC) . . . . .	67
EPC Structure in RFID Labels . . . . .	67
XML-Enabled Printing . . . . .	67
Getting Started with RFID . . . . .	68

Creating Basic RFID Label Formats . . . . .	69
RFID Label Format 1—Write a 96-bit Tag in Hexadecimal . . . . .	70
RFID Label Format 2—Write a 64-bit Tag in Hexadecimal . . . . .	71
RFID Label Format 3—Write a 96-bit Tag in ASCII . . . . .	72
RFID Label Format 4—Read Data from Tag and Print on Label . . . . .	73
RFID Label Format 5—Write Tag, Read Tag, and Print Data on Label . . . . .	74
RFID Label Format 6—Write Tag, Read Tag, and Return Results to Host . . . . .	75
ZPL II Commands for RFID . . . . .	77
^HR Calibrate RFID Transponder Position . . . . .	78
^HV Host Verification . . . . .	80
^RB Define EPC Data Structure . . . . .	81
^RF Read or Write RFID Format . . . . .	83
^RM Enable RFID Motion . . . . .	85
^RR Specify RFID Retries for a Block . . . . .	86
^RS RFID Setup . . . . .	87
^RT Read RFID Tag . . . . .	91
^RW Set RFID Read and Write Power Levels . . . . .	93
^RZ Set RFID Tag Password . . . . .	94
^WT Write Tag . . . . .	95
^WV Verify RFID Write Operation . . . . .	97
<b>6 • Data Ports . . . . .</b>	<b>99</b>
Parallel Port . . . . .	100
Serial Port . . . . .	102
Serial Pin Configuration . . . . .	103
RS-232 Interface Connections . . . . .	104
RS-422/RS-485 Interconnections . . . . .	106
USB 2.0 Port . . . . .	107
<b>7 • Memory Cards . . . . .</b>	<b>109</b>
PCMCIA Memory Card . . . . .	110
CompactFlash Card . . . . .	112
<b>8 • Routine Maintenance . . . . .</b>	<b>115</b>
Cleaning Schedule . . . . .	116
Clean Exterior . . . . .	116
Clean Interior . . . . .	117
Printhead and Platen Roller . . . . .	117
Sensors . . . . .	119
Snap Plate . . . . .	121
Replace Fuse . . . . .	122

- 9 • Troubleshooting ..... 125**
  - Troubleshooting ..... 126
  - LCD Error Messages ..... 127
  - Print Quality Problems ..... 130
  - Communications Problems ..... 132
  - Miscellaneous Printing Problems ..... 133
  - Printer Diagnostics ..... 134
    - Power-On Self Test ..... 134
    - Additional Printer Self Tests ..... 134
    - Communications Diagnostics Test ..... 139
    - Additional Printer Diagnostics ..... 139
  
- A • Specifications ..... 141**
  - Features ..... 142
    - Standard Features ..... 142
    - Print Modes ..... 142
    - Zebra Programming Language (ZPL II®) ..... 142
    - Bar Codes ..... 143
    - Agency Approvals ..... 143
  - General Specifications ..... 144
    - Electrical Specifications ..... 144
    - Environmental Conditions for Operation and Storage ..... 144
  - Print Specifications by Model ..... 145
  - Ribbon Specifications by Model ..... 147
  - Label Specifications ..... 148
  
- Proprietary Statement ..... 151**
- Warranty Information ..... 153**
- Printer Software and Firmware License Agreement ..... 157**
- Index ..... 163**





---

# Preface

This section provides you with contact information, document structure and organization, and additional reference documents.

**Contents**

Contacts .....	x
Support .....	x
Document Conventions .....	xi
Related Documents .....	.xii

## Contacts

You can contact Zebra Technologies at any of the following:

**Visit us at:** <http://www.zebra.com>

**Our Mailing Addresses:**

**Zebra Technologies Corporation**

333 Corporate Woods Parkway

Vernon Hills, Illinois 60061.3109 U.S.A

Telephone: +1 847.634.6700

Fax: +1 847.913.8766

**Zebra Technologies Europe Limited**

Zebra House

The Valley Centre, Gordon Road

High Wycombe

Buckinghamshire HP13 6EQ, UK

Telephone: +44 (0)1494 472872

Fax: +44 (0)1494 450103

## Support

You can contact Zebra support at:

**Web Address:** [www.zebra.com/SS/service\\_support.htm](http://www.zebra.com/SS/service_support.htm)



**Note** • The web address is case-sensitive.

**US Phone Number** +1 847.913.2259

**UK/International Phone Number** +44 (0) 1494 768289

## Document Conventions

The following conventions are used throughout this document to convey certain information:

**Alternate Color** (online only) Cross-references contain hot links to other sections in this guide. If you are viewing this guide online in .pdf format, you can click the cross-reference ([blue text](#)) to jump directly to its location.

**Command Line Examples** All command line examples appear in Courier New font. For example, type the following to get to the Post-Install scripts in the bin directory:

```
ztools
```

**Files and Directories** All file names and directories appear in Courier New font. For example, the Zebra<version number>.tar file and the /root directory.

### Cautions, Important, Note, and Example



---

**Caution** • Warns you of the potential for electrostatic discharge.

---



---

**Caution** • Warns you of a potential electric shock situation.

---



---

**Caution** • Warns you of a situation where excessive heat could cause a burn.

---



---

**Caution** • Advises you that failure to take or avoid a specific action could result in physical harm to you.

---



---

**Caution** • Advises you that failure to take or avoid a specific action could result in physical harm to the hardware.

---



**Important** • Advises you of information that is essential to complete a task.



**Note** • Indicates neutral or positive information that emphasizes or supplements important points of the main text.



**Example** • Provides an example, often a scenario, to better clarify a section of text.



**Tools** • Tells you what tools you need to complete a given task.

**Illustration Callouts** Callouts are used when an illustration contains information that needs to be labeled and described. A table that contains the labels and descriptions follows the graphic. [Figure 1](#) provides an example.

**Figure 1 • Sample Figure with Callouts**

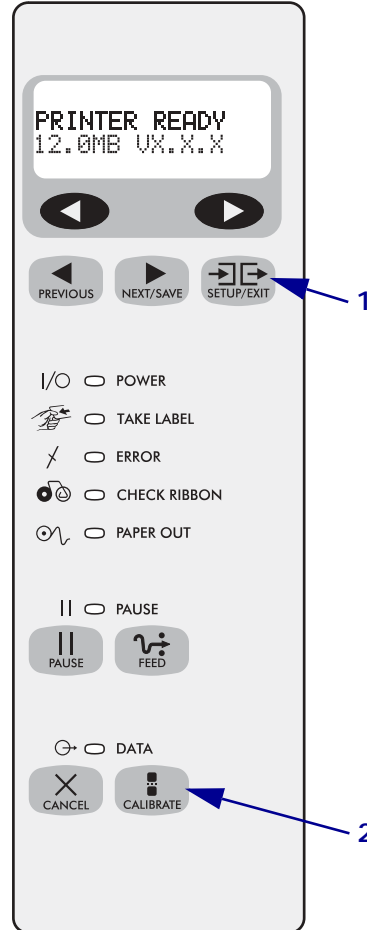

1	SETUP/EXIT button
2	CALIBRATE button

## Related Documents

The following documents might be helpful references:

- *ZPL II® Programming Guide Volume I* (part number 45541L) and *Volume II* (part number 45542L)
- *ZebraNet® PrintServer II™ Installation and User Guide* (part number 45537L)
- *Maintenance Manual* (part number 48152L)



---

# Introduction

This chapter provides a high-level overview of the printer and its components.

## Contents

Exterior View . . . . .	2
Front Panel . . . . .	3
Front Panel Buttons . . . . .	4
Front Panel Lights . . . . .	5
Printer Components . . . . .	6

## Exterior View

The following illustrations show the exterior of the printer.

**Figure 2 • Printer Exterior—Front View**

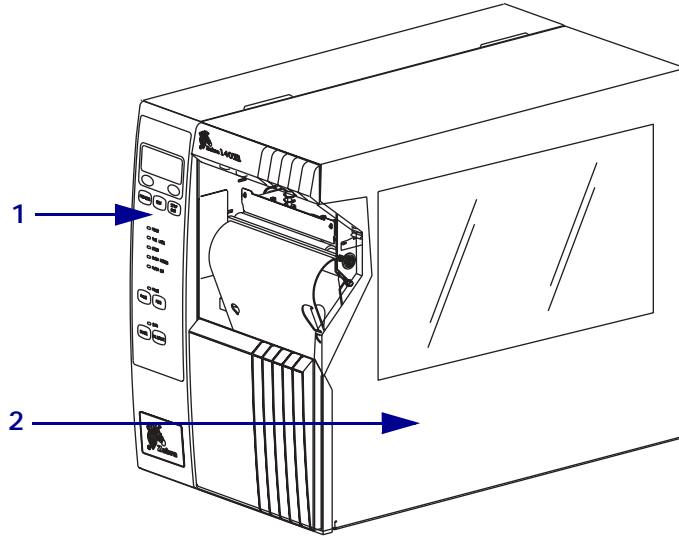

1	Front panel
2	Media door

**Figure 3 • Printer Exterior—Rear View**

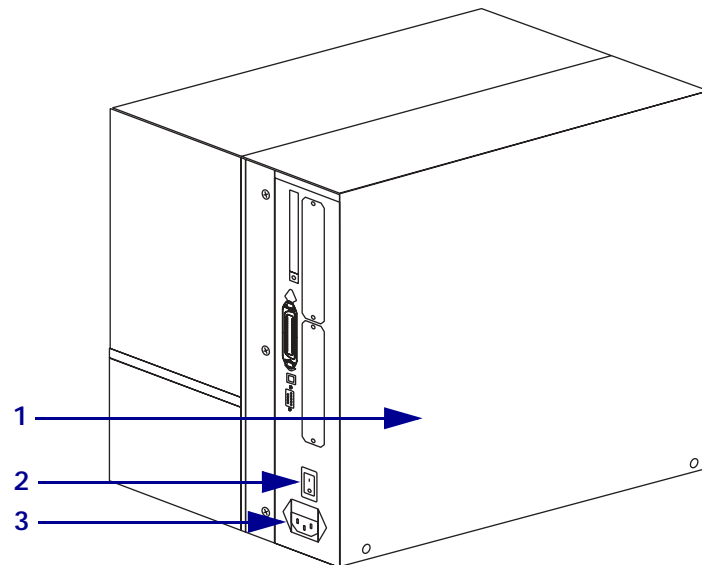

1	Electronics cover
2	Power switch
3	AC power cord connection

## Front Panel

Figure 4 shows the buttons and lights on the front panel. For a description of the front panel buttons, see [Table 1 on page 4](#), and for a description of the front panel lights, see [Table 2 on page 5](#).



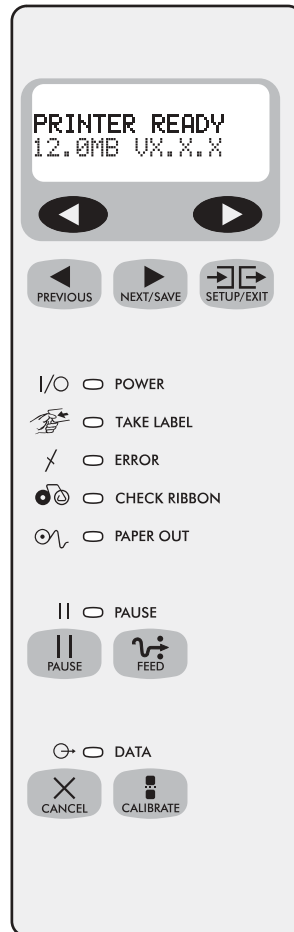





Figure 4 • Front Panel Buttons and Lights



## Front Panel Buttons

This table describes the function of the buttons shown in [Figure 4](#).

**Table 1 • Front Panel Buttons**







Button	Details
LEFT OVAL 	Changes parameter values. Common uses are to increase/decrease a value, answer <b>yes</b> or <b>no</b> , indicate <b>on</b> or <b>off</b> , scroll through several choices, input the password, or set up the printer for a firmware download.
RIGHT OVAL 	Changes parameter values. Common uses are to increase/decrease a value, answer <b>yes</b> or <b>no</b> , indicate <b>on</b> or <b>off</b> , scroll through several choices, input the password, or set up the printer for a firmware download.
SETUP/EXIT 	Enters and exits the setup mode.
PREVIOUS 	While in setup mode, scrolls to the previous parameter. Press and hold this button to scroll back quickly through parameter sets.
NEXT/SAVE 	While in setup mode, scrolls to the next parameter. Press and hold this button to scroll forward quickly through parameter sets. When exiting setup mode, this button scrolls through the save options.
PAUSE 	Starts and stops the printing process and allows other buttons to be used. If an error messages is on the LCD, pressing this button after the problem is resolved clears the error and allows printing to resume.
FEED 	Forces the printer to feed a blank label each time the button is pressed. <ul style="list-style-type: none"> <li>• If the printer is not printing, one blank label immediately feeds.</li> <li>• If the printer is printing, one blank label feeds after the current batch of labels is complete.</li> </ul>
CANCEL 	In the pause mode, this button cancels print jobs. <ul style="list-style-type: none"> <li>• If there are multiple print jobs in the print queue, press <b>CANCEL</b> once for each print job to be deleted.</li> <li>• To delete all print jobs, hold <b>CANCEL</b> for several seconds. The <b>DATA</b> light turns off.</li> </ul>
CALIBRATE 	This button can be used to calibrate the printer for the following: <ul style="list-style-type: none"> <li>• Media length</li> <li>• Media type (continuous or non-continuous)</li> <li>• Print mode (direct thermal or thermal transfer)</li> <li>• Sensor values</li> </ul> For more information on calibration, see <a href="#">Calibrate the Printer on page 35</a> .



## Front Panel Lights

This table details the lights shown in [Figure 4 on page 3](#).

**Table 2 • Front Panel Lights**

Light	Details
POWER 	Indicates printer power status. <ul style="list-style-type: none"> <li>• <b>Off</b> — printer is off.</li> <li>• <b>On</b> — printer is on.</li> </ul>
TAKE LABEL 	<ul style="list-style-type: none"> <li>• <b>Off</b> — Normal operation.</li> <li>• <b>Flashing</b> — (<i>Peel-Off Mode only.</i>) The label is available. Printing is paused until the label is removed.</li> </ul>
ERROR 	Indicates printer operation. <ul style="list-style-type: none"> <li>• <b>Off</b> — Normal operation.</li> <li>• <b>Flashing</b> — printer pauses until the error condition is resolved and the PAUSE button is pressed.</li> </ul>
CHECK RIBBON 	<ul style="list-style-type: none"> <li>• <b>Off</b> — Normal operation; ribbon (if used) is properly loaded.</li> <li>• <b>On</b> — No ribbon is detected under the ribbon sensor. Printing is paused, the LCD shows an error message, and the PAUSE light is on.</li> </ul>
PAPER OUT 	Indicates that labels need to be reloaded.
PAUSE 	<ul style="list-style-type: none"> <li>• <b>Off</b> — normal operation.</li> <li>• <b>On</b> — all printing operations have stopped. Either PAUSE was pressed, a pause command was included in the label format, the on-line verifier detected an error, or a printer error was detected.</li> </ul>
DATA 	<ul style="list-style-type: none"> <li>• <b>Off</b> — Normal operation. No data being received or processed.</li> <li>• <b>On/Blinking</b> — Data processing or printing is taking place. Data is being received.</li> </ul>

## Printer Components

Figure 5 shows a side view of the printer's internal components.



**Note** • Depending on the printer options that you selected, your printer could look slightly different. For more about printer options, go to [www.zebra.com](http://www.zebra.com).

Figure 5 • Internal Components

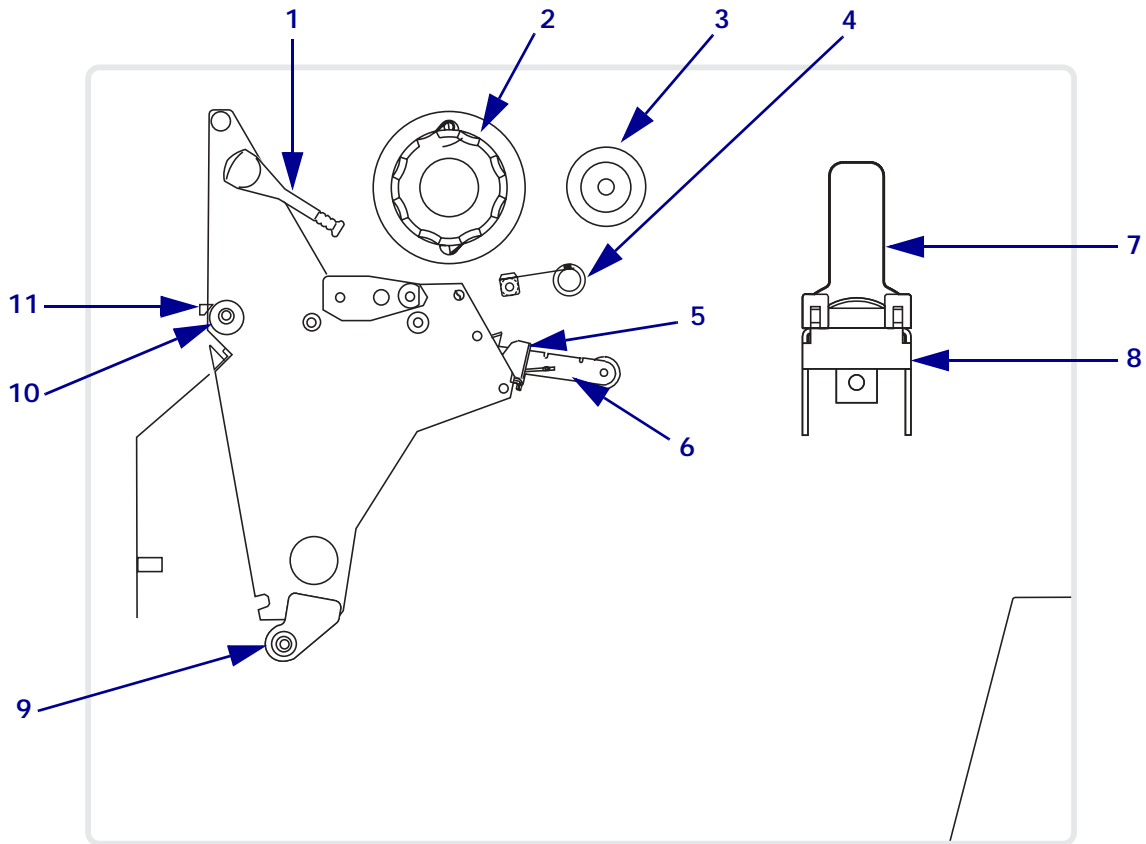

1	Printhead lever
2	Ribbon take-up spindle
3	Ribbon supply spindle
4	Ribbon dancer assembly (only on select models)
5	Media guide
6	Media dancer roller assembly
7	Media supply guide
8	Media supply hanger
9	Lower roller
10	Platen roller
11	Tear-off bar



---

# Printer Setup

This chapter provides the tasks that you must complete and the issues that you must consider before you load and configure your printer.

## Contents

Before You Begin . . . . .	8
Unpack and Inspect the Printer . . . . .	9
Report Shipping Damage. . . . .	9
Store or Reship the Printer. . . . .	9
Select a Site for the Printer . . . . .	10
Select a Surface. . . . .	10
Provide Proper Operating Conditions . . . . .	10
Allow Proper Space . . . . .	10
Provide a Data Source . . . . .	10
Connect the Printer to a Power Source . . . . .	11
Power Cord Specifications. . . . .	11
Select a Communication Interface . . . . .	12
Data Cable Requirements . . . . .	13
Types of Media . . . . .	14
Ribbon . . . . .	16
When to Use Ribbon . . . . .	16
Coated Side of Ribbon. . . . .	16

## Before You Begin

Review this checklist, and resolve any issues before you begin setting up your printer. When you are ready, continue with [Printer Operation on page 19](#).

- Unpack and Inspect** Have you unpacked the printer and inspected it for damage? If you have not, see [Unpack and Inspect the Printer on page 9](#).
- Select a Site** Have you selected an appropriate location for the printer? If you have not, see [Select a Site for the Printer on page 10](#).
- Attach Power Cord** Do you have the correct power cord for your printer? If you are unsure, see [Power Cord Specifications on page 11](#). To attach the power cord and connect the printer to a power source, see [Connect the Printer to a Power Source on page 11](#).
- Connect to a Data Source** Have you determined how the printer will be connected to a data source (usually a computer)? For more information, see [Select a Communication Interface on page 12](#).
- Select Media** Do you have the correct media for your application? If you are unsure, see [Types of Media on page 14](#).
- Select Ribbon** Do you need to use ribbon, and is the appropriate ribbon available, if needed? If you are unsure, see [Ribbon on page 16](#).

## Unpack and Inspect the Printer

When you unpack the printer, save all packing materials. When the printer is out of the box, raise the printer's media door, and remove the power cord.

Inspect the printer for possible damage incurred during shipment. Check all exterior surfaces for damage. Raise the media door, and inspect the media compartment for damage to components.

### Report Shipping Damage

If you discover shipping damage upon inspection:

- Immediately notify the shipping company of the damage, and file a damage report with them. Zebra is not responsible for any damage incurred during shipment of the equipment and does not repair this damage under warranty.
- Keep all packaging material for shipping company inspection.
- Notify your authorized Zebra reseller.

### Store or Reship the Printer

If you are not placing the printer into immediate operation, repackage it using the original packing materials. You may store the printer under the following conditions:

- Temperature:  $-40^{\circ}$  to  $140^{\circ}$ F ( $-40^{\circ}$  to  $60^{\circ}$ C)
- Relative humidity: 5% to 85% non-condensing

If you must ship the printer, remove any ribbon and media from the supply spools to avoid damaging the printer. Carefully pack the printer into the original container or a suitable alternate container to avoid damage during transit.

## Select a Site for the Printer

Consider the following when selecting an appropriate location for your printer.

### Select a Surface

Select a solid, level surface of sufficient size and strength to accommodate the printer and other equipment (such as a computer), if necessary. The choices include a table, countertop, desk, or cart.

### Provide Proper Operating Conditions

Because the printer was designed and is fabricated as an industrial-type unit, it functions satisfactorily in a location that conforms to specified environmental and electrical conditions, including a warehouse or factory floor. For more information on the required conditions, see [General Specifications on page 144](#).

[Table 3](#) shows the temperature and relative humidity requirements for the printer when it is operating.

**Table 3 • Operating Temperature and Humidity**

Mode	Temperature	Relative Humidity
Thermal Transfer	41° to 104°F (5° to 40°C)	20 to 85% non-condensing
Direct Thermal	32° to 104°F (0° to 40°C)	20 to 85% non-condensing

### Allow Proper Space

The printer should have enough space around it for you to be able to open the media door. To allow for proper ventilation and cooling, leave open space on all sides of the printer.

---

**Caution •** Do not place any padding or cushioning material behind or under the printer because this restricts air flow and could cause the printer to overheat.

---

### Provide a Data Source

If the printer will be located away from the data source, the selected site must provide the appropriate connections to that data source. For more information on the types of communication interfaces, see [Select a Communication Interface on page 12](#).

## Connect the Printer to a Power Source



**Caution** • For personnel and equipment safety, always use an approved three-conductor power cord specific to the region or country intended for installation. This cord must use an IEC 320 female connector and the appropriate region-specific three-conductor grounded plug configuration.

**To connect the printer to a power source, complete these steps:**

1. Turn the printer power switch (located on the rear of the printer) to the Off (O) position.
2. Plug the power cord into the mating connector on the rear of the printer.
3. Plug the other end of the power cord into the power source.

### Power Cord Specifications

Depending on how your printer was ordered, a power cord may or may not be included. If one is not included or if the one included is not suitable for your requirements, refer to the following guidelines:

- The overall cord length must be less than 9.8 ft (3.0 m).
- The cord must be rated for at least 5 A, 250 V.
- The chassis ground (earth) **must** be connected to ensure safety and reduce electromagnetic interference. The third wire in the power cord grounds the connection (Figure 6).

**Figure 6 • Power Cord Specifications**

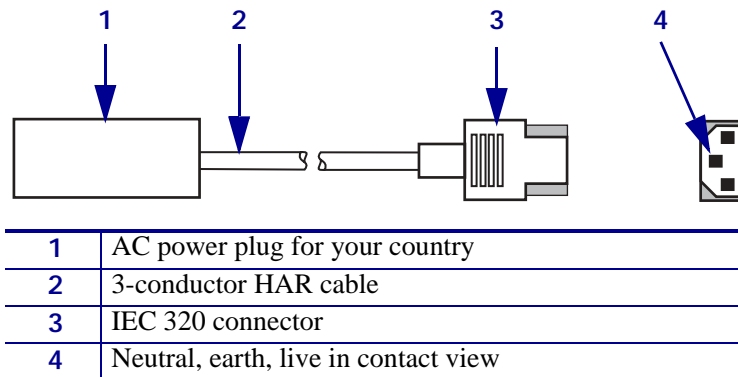

- The AC power plug and the IEC 320 connector must bear the certification mark of at least one of the known international safety organizations shown in Figure 7.

**Figure 7 • International Safety Organization Marks**

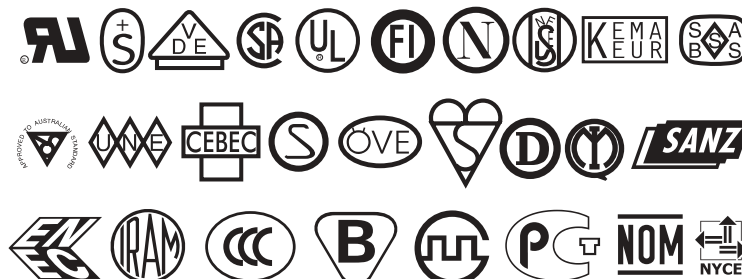

## Select a Communication Interface

The way that you connect your printer to a data source depends on the communication options installed in the printer.

**Standard interfaces:** The standard communication interfaces are an RS-232 serial data port, a bidirectional parallel port, and a USB 2.0 port.



**Note** • RS-422 and RS-485 serial data ports are available through an adapter. A DB-25 cable and a USB 2.0 cable are also available.

Figure 8 shows the location of the communication interfaces on the back of the printer. For more information about these interfaces, see [Data Ports on page 99](#).

**Figure 8 • Communication Interfaces**

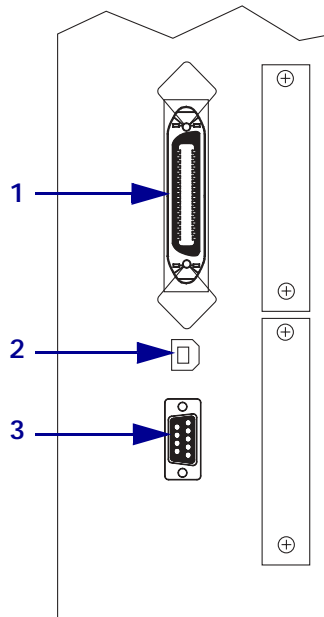

1	Parallel port
2	USB 2.0 port
3	Serial port

### Optional Print Servers:

- ZebraNet PrintServer II (PSII). For more information on PSII, see the *PrintServer II User and Reference Guide* (Zebra part number 45537L).



## Data Cable Requirements

Data cables must be fully shielded and fitted with metal or metallized connector shells. Shielded cables and connectors are required to prevent radiation and reception of electrical noise.

To minimize electrical noise pickup in the cable:

- Keep data cables as short as possible.
- Do not bundle the data cables tightly with the power cords.
- Do not tie the data cables to power wire conduits.



**Note** • Zebra printers comply with FCC Rules and Regulations, Part 15 for Class B Equipment using fully shielded, 6.5 ft (2 m) data cables. Use of unshielded cables may increase radiation above the Class B limits.



**Note** • RS-422 and RS-485 applications should use twisted shielded pairs as recommended in the TIA/EIA-485 Specification.

## Types of Media

The printer can use various types of media (Table 4). We strongly recommend the use of Zebra-brand supplies for continuous high-quality printing. A wide range of paper, polypropylene, polyester, and vinyl stock has been specifically engineered to enhance the printing capabilities of the printer and to ensure against premature printhead wear.

**Table 4 • Types of Media**

Media Type	How It Looks	Description
<p><b>Non-Continuous Roll Media</b></p>		<p>The media is wound on a core. Individual labels are separated by a gap, black mark, notch, or hole, which enables you to see where one label ends and the next one begins. When using media that has holes or notches, position the media sensor directly over a hole or notch. Figure 9 shows different types of non-continuous media.</p> <p><b>Figure 9 • Non-Continuous Web Media</b></p> 
<p><b>Continuous Roll Media</b></p>		<p>The media is wound on a core and is without gaps, holes, notches, or black marks. This allows the image to be printed anywhere on the label.</p>

Table 4 • Types of Media (Continued)

Media Type	How It Looks	Description
<b>Fanfold Media</b>		The media is folded in a zigzag pattern.
<b>RFID “Smart” Media</b>		Each label has a radio frequency identification (RFID) chip and antenna inlay embedded between the label and the liner. The media is made from the same materials and adhesives as non-RFID labels. The outline of the transponder (which varies by manufacturer) can be seen through the label. All “smart” labels have memory that can be read, and many have memory that can be encoded.

## Ribbon

Ribbon is a thin film that is coated on one side with wax, resin, or wax resin, which is transferred to the media during the thermal transfer process. The media determines whether you need to use ribbon and how wide the ribbon must be.

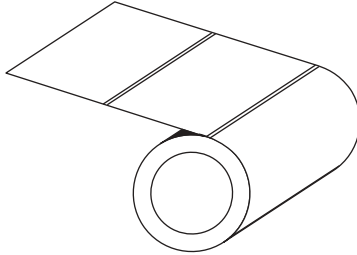
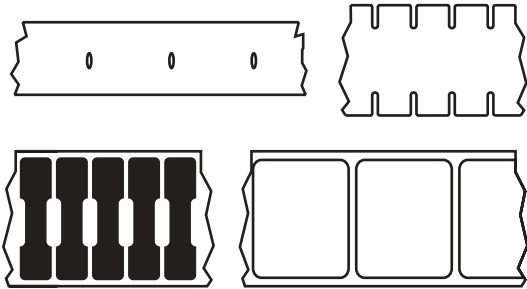
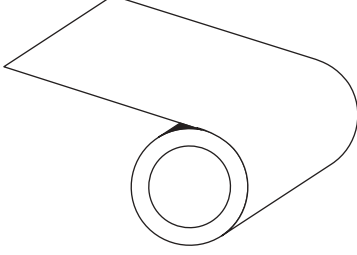
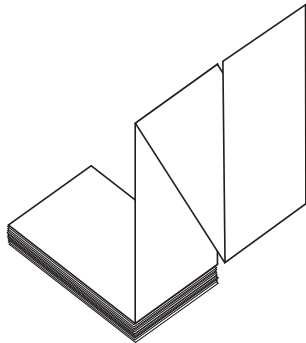
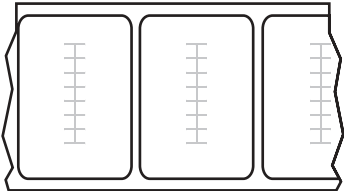
When ribbon is used, it must be as wide as or wider than the media being used. If the ribbon is narrower than the media, areas of the printhead are unprotected and subject to premature wear.

### When to Use Ribbon

Thermal transfer media requires ribbon for printing while direct thermal media does not. To determine if ribbon must be used with a particular media, perform a media scratch test.

**To perform a label scratch test, complete these steps:**

1. Scratch the print surface of the media rapidly with your fingernail.
2. Did a black mark appear on the media?

If a black mark...	Then the media is...
Does not appear on the media	<b>Thermal transfer.</b> A ribbon is required.
Appears on the media	<b>Direct thermal.</b> No ribbon is required.

### Coated Side of Ribbon

Ribbon can be wound with the coated side on the inside or outside (Figure 10). This printer can only use ribbon that is coated on the outside. If you are unsure which side of a particular roll of ribbon is coated, perform an adhesive test or a ribbon scratch test to determine which side is coated.

**Figure 10 • Ribbon Coated on Outside or Inside**



## Adhesive Test

If you have labels available, perform the adhesive test to determine which side of a ribbon is coated. This method works well for ribbon that is already installed.

### To perform an adhesive test, complete these steps:

1. Peel a label from its liner.
2. Press a corner of the sticky side of the label to the outer surface of the roll of ribbon.
3. Peel the label off of the ribbon.
4. Observe the results. Did flakes or particles of ink from the ribbon adhere to the label?

If ink from the ribbon...	Then...
Adhered to the label	The ribbon is coated on the <b>outer</b> surface.
Did not adhere to the label	The ribbon is coated on the <b>inner</b> surface. To verify this, repeat the test on the inner surface of the roll of ribbon.

## Ribbon Scratch Test

Perform the ribbon scratch test when labels are unavailable.

### To perform a ribbon scratch test, complete these steps:

1. Unroll a short length of ribbon.
2. Place the unrolled section of ribbon on a piece of paper with the outer surface of the ribbon in contact with the paper.
3. Scratch the inner surface of the unrolled ribbon with your fingernail.
4. Lift the ribbon from the paper.
5. Observe the results. Did the ribbon leave a mark on the paper?

If the ribbon...	Then...
Left a mark on the paper	The ribbon is coated on the outer surface.
Did not leave a mark on the paper	The ribbon is coated on the <b>inner</b> surface. To verify this, repeat the test on the other surface of the roll of ribbon.





---

# Printer Operation

If you have completed the tasks and resolved the issues in the checklist in *Before You Begin* on page 8, follow the instruction in this chapter to load and calibrate your printer and to print configuration labels.

## Contents

Loading the Media .....	20
Load Roll Media .....	21
Load Fanfold Media .....	24
Loading Ribbon .....	26
Remove Used Ribbon .....	31
Print a Printer Configuration Label .....	32
Print a Network Configuration Label .....	34
Calibrate the Printer .....	35
Adjust Media Sensors .....	37
Adjust Printhead Pressure and Toggle Position .....	39
Toggle Position Adjustment .....	39
Printhead Pressure Adjustment .....	40

## Loading the Media

This section gives you a series of instructions to load labels for a standard printer in Tear-Off mode (Figure 11). You can use roll or fanfold media in this printer. For more information about the types of media, see *Types of Media* on page 14.

- To load roll media, see *Load Roll Media* on page 21.
- To load fanfold media, see *Load Fanfold Media* on page 24.



**Caution** • Be sure the printer is Off (O) if you have connected the power cable.

---

**Figure 11 • Printer Loaded in Tear-Off Mode**





## Load Roll Media

Roll media feeds through the printer from the media hanger or media supply spindle. [Figure 12](#) identifies the components of the printer with which you need to be familiar to load roll media in Tear-Off mode.

**Figure 12 • Interior Components for Media Loading (Tear-Off Mode)**

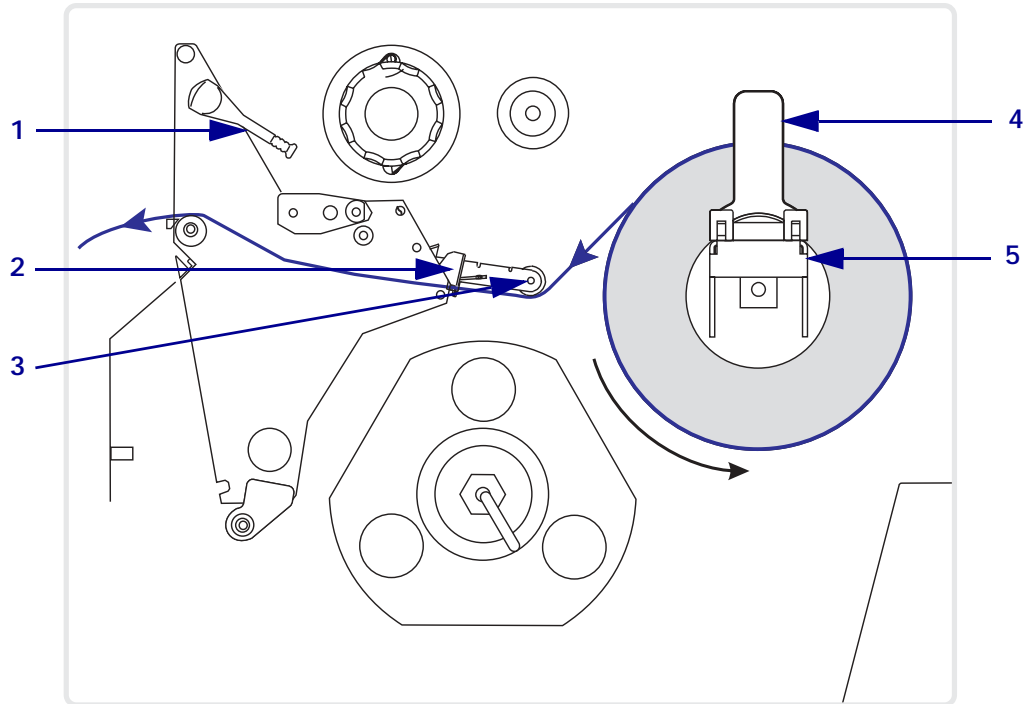

1	Printhead lever
2	Media guide
3	Media guide roller
4	Media guide on media hanger
5	Media hanger

**To load roll media, complete these steps:**

1. Open the printhead.
2. See [Figure 13](#). Slide the media guide away from the printer frame. You may need to loosen the media guide thumb screw.

**Figure 13 • Adjusting the Media Guide**

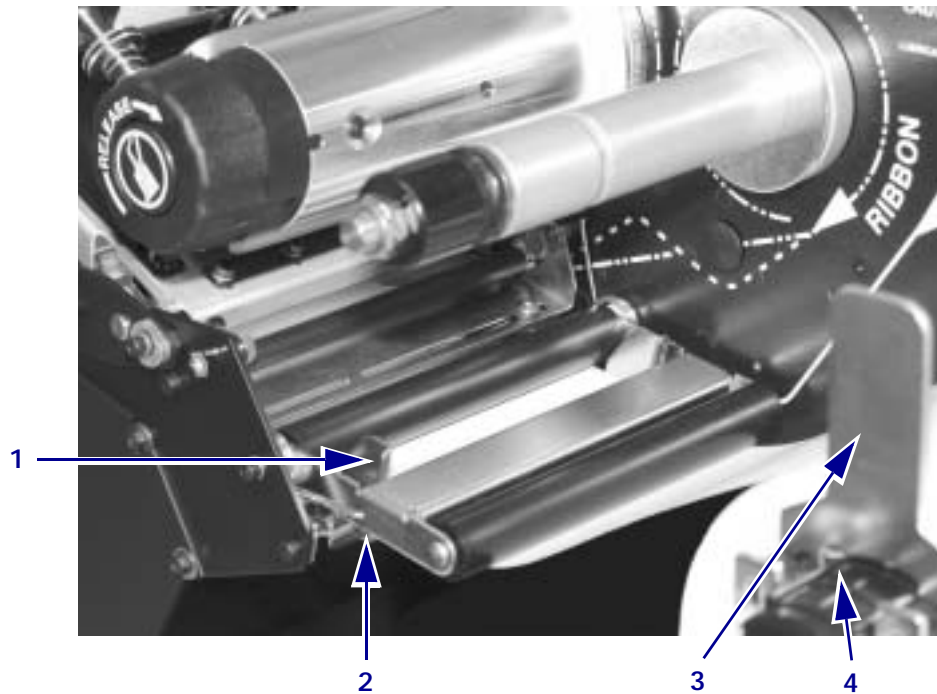

1	Media guide
2	Location of media guide thumb screw
3	Media guide on media hanger
4	Media hanger

3. Place the roll of media on the media hanger.
4. Push the media core toward the printer frame. Make sure that the labels are aligned with the media core.
5. Adjust the media guide on the media hanger so it just touches but does not restrict the media.
6. See [Figure 14](#). Feed the media under the media guide roller and under the upper media sensor assembly.



**Important •** Be sure to thread the media under the upper media sensor assembly and the ribbon guide roller. If you thread the media over these, the media blocks the ribbon sensor.

Figure 14 • Threading Media

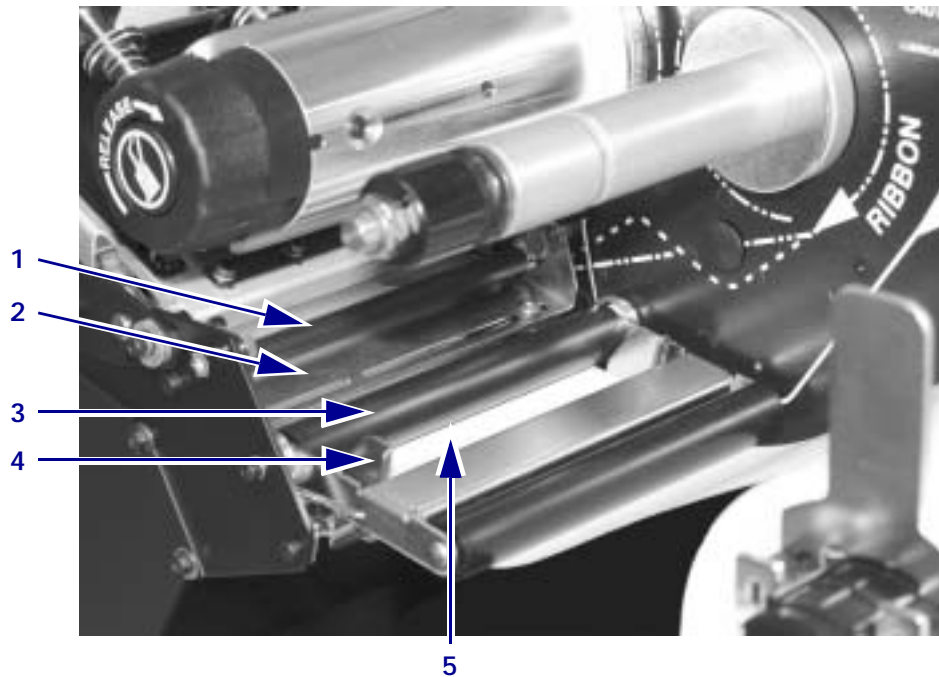

1	Ribbon guide roller
2	Upper media sensor assembly
3	Media guide roller
4	Media guide
5	Media

7. Pull the media through under the printhead.
8. Adjust the media guide so that it just touches but does not restrict the media. The labels should lie flat.
9. Which type of media are you using?

If you are...	Then...
Using <b>direct thermal</b> media	Close the printhead, and then go to <a href="#">Print a Printer Configuration Label on page 32</a> .
Using <b>thermal transfer</b> media	Go to <a href="#">Loading Ribbon on page 26</a> .
Not sure	Go to <a href="#">When to Use Ribbon on page 16</a> .

## Load Fanfold Media

Fanfold media feeds through either the bottom or rear access slot from outside the printer. The media hanger and media supply spindle are **not** used with fanfold media.

### To load fanfold labels, complete these steps:

1. Slide the printhead lever to the Open position.
2. See [Figure 13 on page 22](#). Slide the media guide away from the printer frame. You may need to loosen the media guide screw.
3. How do you want to feed the fanfold labels?
  - **From the bottom slot in the printer body.**  
[Figure 15](#) shows the printer with fanfold labels loaded through the bottom slot.

**Figure 15 • Fanfold Media—Bottom Loading**

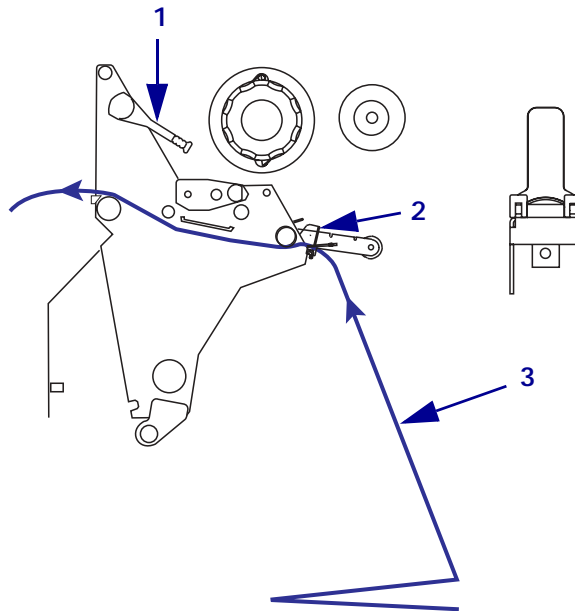

1	Printhead lever (shown in the Open position)
2	Media guide
3	Fanfold labels

- From the rear slot in the printer body.  
Figure 16 shows the printer with fanfold labels loaded through the rear slot.

Figure 16 • Fanfold Media—Rear Loading

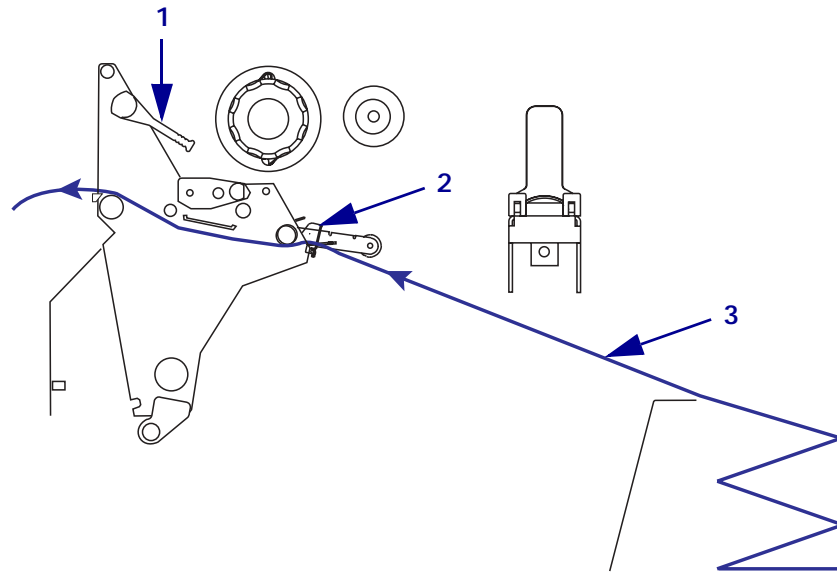

1	Printhead lever (shown in the Open position)
2	Media guide
3	Fanfold labels

4. See Figure 14 on page 23. Feed the media under the media guide roller and under the upper media sensor assembly.



**Important** • Be sure to thread the media under the upper media sensor assembly and the ribbon guide roller. If you thread the media over these, the media blocks the ribbon sensor.

5. Pull the media through under the printhead.
6. Adjust the media guide so that it just touches, but does not restrict, the edge of the media. The labels should lie flat.
7. Which type of media are you using?

If you are...	Then...
Using direct thermal media	Close the printhead, and then go to <i>Print a Printer Configuration Label</i> on page 32.
Using thermal transfer media	Go to <i>Loading Ribbon</i> on page 26.
Not sure	Go to <i>When to Use Ribbon</i> on page 16.

## Loading Ribbon

Before you load ribbon, make sure that the media that you are using needs ribbon. Only thermal transfer media requires ribbon. Ribbon is not required with direct thermal media, though it may be used to protect the printhead from abrasion. For more information, see [When to Use Ribbon on page 16](#).

---

**Caution** • Use ribbon that is wider than the thermal transfer media. If the printhead is not protected by the ribbon, the resulting abrasion from the media may cause premature printhead wear.

---

Figure 17 shows the printer components that are mentioned in the ribbon loading procedure.

**Figure 17 • Interior Components for Ribbon Loading**

**Figure 18 • Ribbon Path**

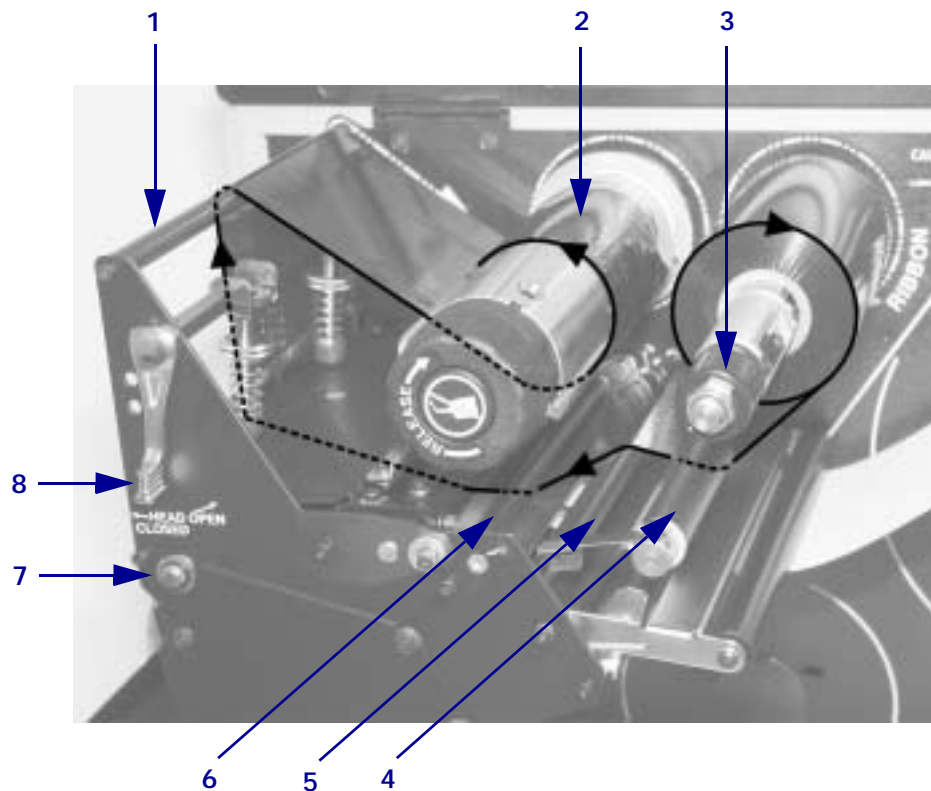

1	Top roller
2	Ribbon take-up spindle
3	Ribbon supply spindle
4	Ribbon dancer assembly upper roller (only on some models)
5	Ribbon dancer assembly lower roller (only on some models)
6	Ribbon guide roller
7	Platen roller (not shown)
8	Printhead lever (shown in the Closed position)

## Create a Ribbon Leader

A ribbon leader makes it easier to load and unload ribbon. Make a leader for your ribbon roll if it does not already have one.

**To make a ribbon leader, complete these steps:**

1. Unroll the ribbon about 6 in. (15 cm).
2. Tear off a strip of labels and backing about 6 in. (15 cm) long from the label roll.
3. Peel a label from the backing.
4. Overlap the ribbon and the backing with the ribbon on top, and use the label to tape them together. This serves as a ribbon leader ([Figure 19](#)).

**Figure 19 • Ribbon Leader**

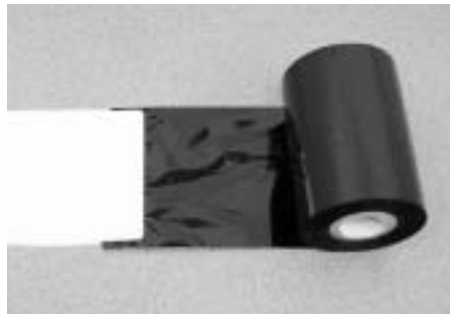

## Load Ribbon

**To load the ribbon, complete these steps:**

1. See [Figure 20](#). Align the segments of the ribbon supply spindle.

**Figure 20 • Ribbon Supply Spindle Segments**

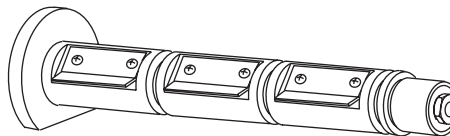

2. Place the roll of ribbon on the ribbon supply spindle, and push the core as far back as it can go.
3. If the printhead is closed, open it using the printhead lever.

4. Does your printer contain a ribbon dancer assembly?

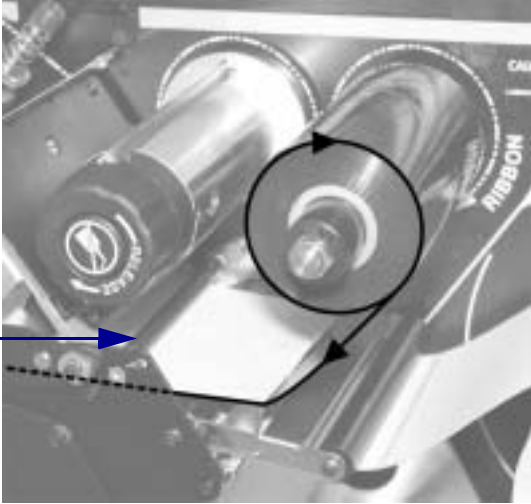
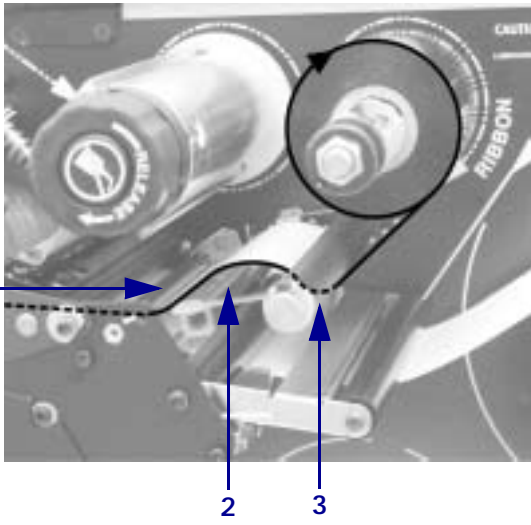
If...	Then...						
<p><b>No</b></p>	<p>See <a href="#">Figure 21</a>. Thread the ribbon under the ribbon guide roller.</p> <p style="text-align: center;"><b>Figure 21 • Loading Ribbon, No Dancer Assembly</b></p>  <table border="1" style="margin-left: auto; margin-right: auto;"> <tr> <td style="text-align: center;"><b>1</b></td> <td>Ribbon guide roller</td> </tr> </table>	<b>1</b>	Ribbon guide roller				
<b>1</b>	Ribbon guide roller						
<p><b>Yes</b></p>	<p>a. See <a href="#">Figure 22</a>. Thread the ribbon under the upper roller of the ribbon dancer assembly and then over the lower roller.</p> <p>b. Thread the ribbon under the ribbon guide roller.</p> <p style="text-align: center;"><b>Figure 22 • Loading Ribbon through the Dancer Assembly</b></p>  <table border="1" style="margin-left: auto; margin-right: auto;"> <tr> <td style="text-align: center;"><b>1</b></td> <td>Ribbon guide roller</td> </tr> <tr> <td style="text-align: center;"><b>2</b></td> <td>Ribbon dancer assembly lower roller</td> </tr> <tr> <td style="text-align: center;"><b>3</b></td> <td>Ribbon dancer assembly upper roller</td> </tr> </table>	<b>1</b>	Ribbon guide roller	<b>2</b>	Ribbon dancer assembly lower roller	<b>3</b>	Ribbon dancer assembly upper roller
<b>1</b>	Ribbon guide roller						
<b>2</b>	Ribbon dancer assembly lower roller						
<b>3</b>	Ribbon dancer assembly upper roller						



5. See [Figure 23](#). Thread the ribbon under the printhead and past the platen roller.

**Figure 23 • Threading Ribbon Under the Printhead**

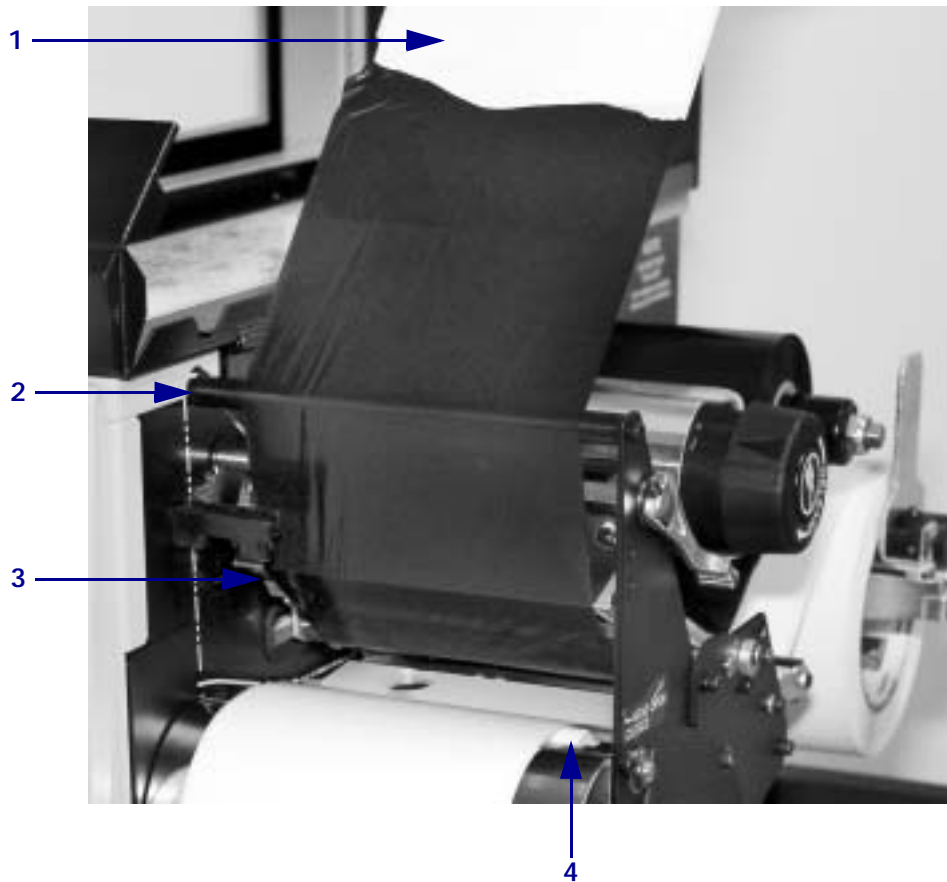

1	Ribbon leader
2	Top roller
3	Printhead
4	Platen roller

6. Pull the ribbon leader over the printhead and above the top roller.

7. See [Figure 24](#). Bring the ribbon under the ribbon take-up spindle, and wrap it around the spindle counter-clockwise.

**Figure 24 • Winding Ribbon around the Ribbon Take-up Spindle**

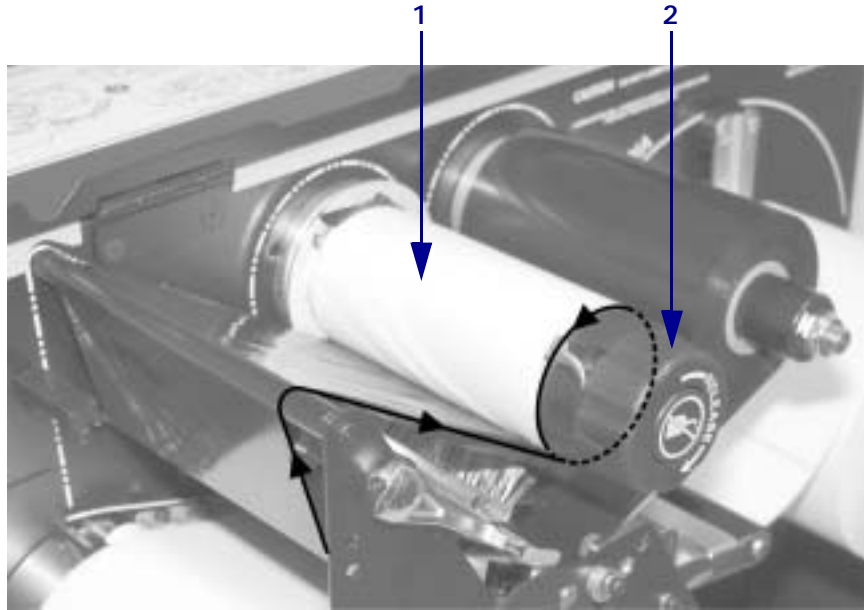

1	Ribbon leader
2	Ribbon take-up spindle

8. Turn the ribbon take-up spindle counterclockwise until the ribbon stays on it, as shown.
9. Close the printhead.

## Remove Used Ribbon

When the ribbon has run out or must be changed, remove the used ribbon from the take-up spindle (Figure 25).

Figure 25 • Ribbon Take-Up Spindle

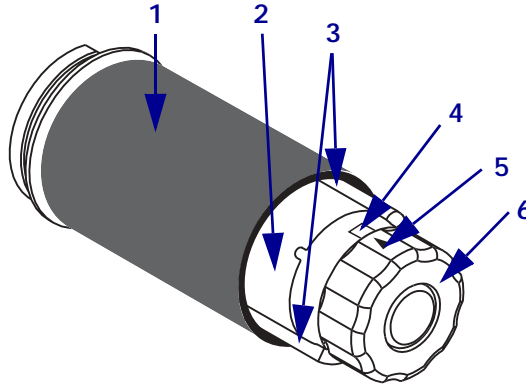

1	Used ribbon
2	Ribbon take-up spindle
3	Ribbon release bars
4	Notch in ribbon take-up spindle
5	Arrow on ribbon take-up spindle
6	Ribbon release knob

### To remove used ribbon, complete these steps:

1. Open the printhead.
2. Has the ribbon run out?

If the ribbon...	Then
<b>Ran out</b>	Continue with the next step.
<b>Did not run out</b>	Tear or cut the ribbon as close to the ribbon take-up spindle as possible. <b>Caution</b> • Do not cut through the ribbon that is on the take-up spindle because you may damage the spindle. Use the ribbon release knob to slide the ribbon off of the spindle.

3. While holding the ribbon take-up spindle, turn the ribbon release knob clockwise until it stops.  
The ribbon release bars pivot down, easing the spindle's grip on the used ribbon.
4. Slide the used ribbon off of the ribbon take-up spindle.
5. Align the arrow on the ribbon take-up spindle knob with the notch in the ribbon take-up spindle.

## Print a Printer Configuration Label

When you have loaded the media and ribbon (if necessary), print a configuration label as a record of your printer's current settings. Keep the label to use when troubleshooting printing problems.



---

**Caution** • For personal and equipment safety, always use an approved three-conductor power cord specific to the region or country intended for installation. This cord must use an IEC 320 female connector and the appropriate region-specific three-conductor grounded plug configuration.

---

### To print a configuration label, complete these steps:

1. Connect the power cord to the power connection on the back of the printer.
2. To confirm the power connection, turn the printer On (**I**).  
The printer performs the power-up self test (POST). When the test is complete, **PRI NTER READY** displays on the front panel LCD.
3. Does the front panel LCD display **PRI NTER READY**?

If...	Then...
<b>Yes</b>	Continue with the next step.
<b>No</b>	Go to <i>Troubleshooting</i> on page 125.

4. Turn the printer Off (**O**).
5. Press and hold **CANCEL** while turning the printer On (**I**).
6. Release **CANCEL** when the **DATA** light turns off (approximately five seconds).  
The configuration label prints (Figure 26).
7. Did the label print?

If a configuration label...	Then...
Printed	Connect the printer to your data source. Communication can be handled in many different ways. More information about the options is available in <i>Select a Communication Interface</i> on page 12.
Did not print	Sensors out of position is a common cause of printing problems. Refer to <i>Adjust Media Sensors</i> on page 37. For additional assistance, refer to <i>Troubleshooting</i> on page 125.

Figure 26 • Printer Configuration Label

PRINTER CONFIGURATION	
Zebra Technologies	
ZTC 170Xi111IPPlus-300dpi	
ZBR2393398	
04.0.....	DARKNESS
2 IPS.....	PRINT SPEED
+000.....	TEAR OFF
TEAR OFF.....	PRINT MODE
NON-CONTINUOUS.....	MEDIA TYPE
WEB.....	SENSOR TYPE
DIRECT-THERMAL.....	PRINT METHOD
042 04/12 MM.....	PRINT WIDTH
1844.....	LABEL LENGTH
8.0IN 202MM.....	MAXIMUM LENGTH
MEDIA DISABLED.....	EARLY WARNING
MAINT. OFF.....	EARLY WARNING
NOT CONNECTED.....	USB COMM.
BIDIRECTIONAL.....	PARALLEL COMM.
RS232.....	SERIAL COMM.
9600.....	BAUD
8 BITS.....	DATA BITS
NONE.....	PARITY
XON/XOFF.....	HOST HANDSHAKE
NONE.....	PROTOCOL
000.....	NETWORK ID
NORMAL MODE.....	COMMUNICATIONS
<-> 7EH.....	CONTROL PREFIX
<^> 5EH.....	FORMAT PREFIX
<. > 2CH.....	DELIMITER CHAR
ZPL II.....	ZPL MODE
CALIBRATION.....	MEDIA POWER UP
CALIBRATION.....	HEAD CLOSE
DEFAULT.....	BACKFEED
+000.....	LABEL TOP
+0000.....	LEFT POSITION
0000.....	HEAD TEST COUNT
1049.....	HEAD RESISTOR
OFF.....	VERIFIER PORT
OFF.....	APPLICATOR PORT
PULSE MODE.....	START PRINT SIG
FEED MODE.....	RESYNCH MODE
04B.....	WEB S.
079.....	MEDIA S.
085.....	RIBBON S.
089.....	TAKE LABEL
050.....	MARK S.
000.....	MARK MED S.
067.....	MEDIA LED
012.....	RIBBON LED
028.....	MARK LED
+10.....	LCD ADJUST
DPS4FXM.....	MODES ENABLED
.....	MODES DISABLED
1984 12/MM FULL.....	RESOLUTION
R80.13.0.OP10 <-.....	FIRMWARE
V30 3303? 5?.....	HARDWARE ID
CUSTOMIZED.....	CONFIGURATION
NONE.....A:	COMPACT FLASH
11776k.....R:	RAM
NONE.....B:	MEMORY CARD
2048k.....E:	ONBOARD FLASH
NONE.....	FORMAT CONVERT
005 DISPLAY.....	P32 INTERFACE
00? POWER SUPPLY.....	P34 INTERFACE
.....	TWINAX/COAX ID
FW VERSION.....	IDLE DISPLAY
11/24/04.....	RTC DATE
12:57.....	RTC TIME
Class 1 64-bit.....	RFID TAG TYPE
POWER TOO HI.....	RFID ERR STATUS
0.....	RFID VALID CTR
0.....	RFID VOID CTR
HIGH.....	RFID READ PWR
HIGH.....	RFID WRITE PWR
TM: 04101801.....	RFID VERSION
1373 IN.....	NONRESET CNTR
1373 IN.....	RESET CNTR1
1373 IN.....	RESET CNTR2
3432 CM.....	NONRESET CNTR
3432 CM.....	RESET CNTR1
3432 CM.....	RESET CNTR2
324 LABELS.....	NONRESET CNTR
324 LABELS.....	RESET CNTR1
324 LABELS.....	RESET CNTR2
AV 55907.04DLL100229.33008.01.VH1....	
2004-11-17 11:54:31	TIME STAMP

FIRMWARE IN THIS PRINTER IS COPYRIGHTED

## Print a Network Configuration Label

If you are using a print server, you can print a network configuration label after the printer is connected to the network.

### To print a network configuration label, complete these steps:

1. On the front panel, press SETUP/EXIT.
2. Use the left or right oval to scroll through the parameters until you reach LIST NETWORK.
3. Press the right oval to confirm printing.

A network configuration label prints (Figure 27). An asterisk designates whether the wired or wireless print server is active. If no wireless print server is installed, the wireless portion of the label does not print.

Figure 27 • Network Configuration Label (With a Wireless Print Server Installed)

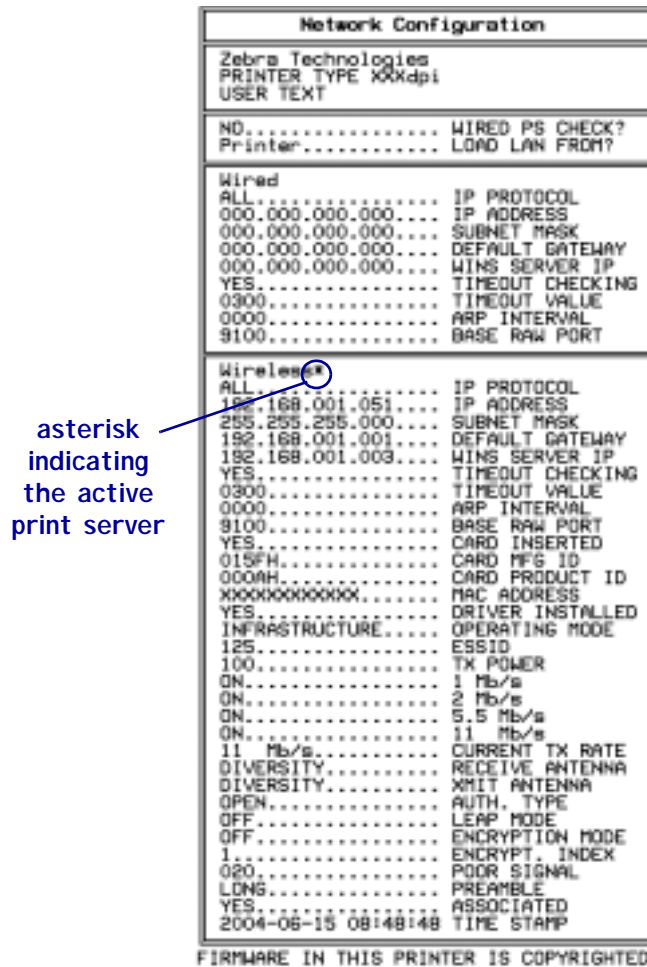

## Calibrate the Printer

Calibrate the printer when it is first put into service. Calibration allows the printer to establish the proper settings for the specific media and ribbon used in your application. You may calibrate the printer at other times as needed. [Table 5](#) shows the different methods for calibration.

**Table 5 • Types of Calibration**

Type of Calibration	Description	When/How It Occurs
<b>Auto-calibration</b>	The printer automatically sets the value it detects for the spaces between labels.	Occurs at the following times: <ul style="list-style-type: none"> <li>When the printer is first turned on if CALIBRATION is selected for <b>MEDI A POWER UP</b> (see <a href="#">Media Power Up on page 54</a>)</li> <li>When the printer feeds media after the printhead is closed if CALIBRATION is selected for <b>HEAD CLOSE</b> (see <a href="#">Head Close on page 54</a>).</li> <li>As part of both the sensor profile and media and ribbon sensor calibration procedures.</li> </ul>
<b>Long (Standard) Calibration</b>	The printer does the following: <ul style="list-style-type: none"> <li>feeds media and ribbon</li> <li>sets the values it detects for media length, media type (continuous or non-continuous), and print mode (thermal transfer or direct thermal)</li> <li>updates the sensor values</li> </ul>	To perform a long calibration, do one of the following: <ul style="list-style-type: none"> <li>Press PAUSE on the front panel to pause the printer, and then press CALIBRATE.</li> <li>Select CALIBRATION for the <b>MEDI A POWER UP</b> or <b>HEAD CLOSE</b> parameter (see <a href="#">Media Power Up on page 54</a> or <a href="#">Head Close on page 54</a>).</li> </ul>
<b>Short Calibration</b>	The printer calibrates using the current sensor values rather than detecting the spaces between labels and resetting the sensors. This calibration sequence uses fewer labels than the long calibration sequence, but it is less reliable because the values that are stored in the sensors could be incorrect.	Select SHORT CAL for the <b>MEDI A POWER UP</b> or <b>HEAD CLOSE</b> parameter (see <a href="#">Media Power Up on page 54</a> or <a href="#">Head Close on page 54</a> ).

**Table 5 • Types of Calibration (Continued)**

<b>Type of Calibration</b>	<b>Description</b>	<b>When/How It Occurs</b>
<b>Sensor Profile Calibration</b>	The printer auto-calibrates and prints a media sensor profile.	Select the <b>SENSOR PROFILE</b> option on the front panel. See <i>Sensor Profile</i> on page 49 for instructions.
<b>Media and Ribbon Sensor Sensitivity Calibration</b>	One of the most common adjustments to printer settings. The printer resets the sensitivity of the sensors to detect correctly the media and ribbon that you are using. If you change the type of ribbon and/or media, you might need to reset the sensitivity of the media and ribbon sensors. When the sensors are at their new sensitivity, the printer performs an auto-calibration.	Select the <b>MEDIA AND RIBBON CALIBRATE</b> option on the front panel. See <i>Calibrate Media and Ribbon Sensors</i> on page 50 for instructions.



## Adjust Media Sensors

The transmissive sensor consists of two sections: a light source (the lower media sensor) and a light sensor (the upper media sensor). The media passes between the two.

Adjust these sensors only when the printer cannot detect the top of the label. The front panel LCD displays **ERROR CONDITION PAPER OUT**, even though there are labels loaded in the printer.



**Note** • The upper media sensor can be positioned along the inside half of the media (the side closest to the back of the printer) or the outside half of the media (the side farthest from the back of the printer).

**To adjust the upper media sensor for the inside half of the media, complete these steps:**

1. Remove the ribbon (if ribbon is used).
2. Locate the upper media sensor (Figure 28). The upper media sensor eye is directly below the adjustment screw head.

**Figure 28 • Upper Media Sensor Location**

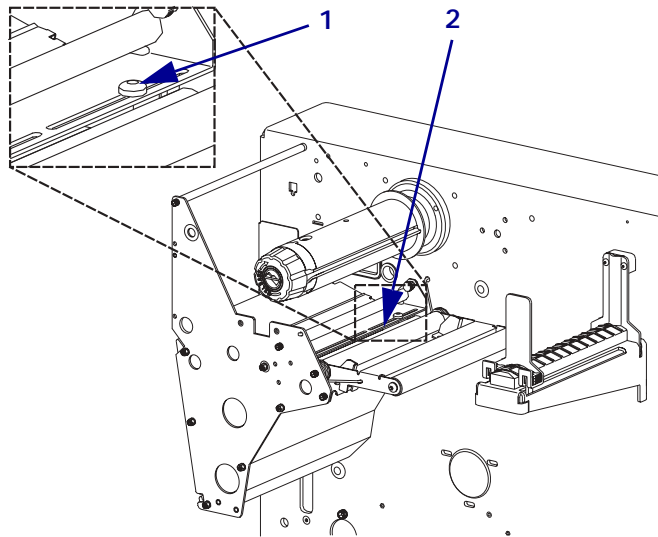

1	Upper media sensor adjustment screw
2	Upper media sensor

3. Using a Phillips-head screwdriver, slightly loosen the upper media sensor adjustment screw.
4. Using the tip of the screwdriver, slide the upper sensor along the slot to the desired position (for non-continuous media with a notch or hole in the media, the sensor must be directly above the notch or hole).
5. Tighten the adjustment screw to secure the upper media sensor.

**To adjust the upper media sensor for the outside half of the media:**

1. Remove the ribbon (if ribbon is used).
2. Locate the upper media sensor. The upper media sensor eye is directly below the adjustment screw head.
3. Using a Phillips-head screwdriver, remove the upper media sensor adjustment screw.
4. Lift the upper media sensor assembly from the slot, and move it and the wire cover to the outside slot. Carefully pull the wires through the cable tie. You may need to set aside the sensor wire cover if the adjustment is too far to the outside.
5. Replace and slightly tighten the adjustment screw.
6. Slide the upper media sensor along the slot to the desired position (for non-continuous media with a notch or hole in the media, the sensor must be directly above the notch or hole).
7. Tighten the adjustment screw.
8. Make sure that the wires are routed back into the groove of the media sensor bracket.

**To adjust the lower media sensor, complete these steps:**

1. Locate the lower media sensor assembly under the rear roller (Figure 29). The sensor is a spring clip holding a circuit board.

**Figure 29 • Lower Media Sensor Location**

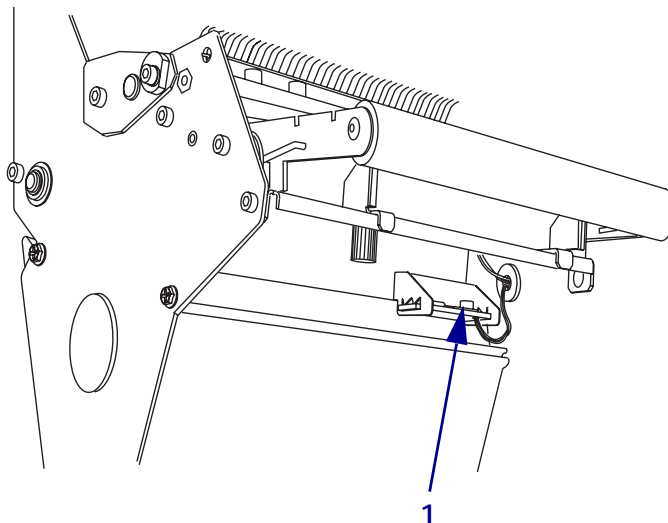

1	Lower media sensor
---	--------------------

2. Slide the lower sensor until it is under the upper media sensor. Gently pull wires out as needed (wires should have a little slack).
3. If you move the sensor inward and a large loop of wire develops, remove the electronics cover from the side of the printer, and gently pull the wires through. Clamp the wires so that they do not touch any drive belts.

## Adjust Printhead Pressure and Toggle Position

Printhead pressure is one factor that affects print quality. If the toggle pressure is too light or uneven, the labels and ribbon may slip.



**Important** • Print quality depends on the labels and ribbon used as well as the toggle pressure. Make sure that your labels and ribbon are right for your application.

- **Direct thermal media** does not need ribbon.
- **Thermal transfer media** needs ribbon.

### Toggle Position Adjustment

You may need to adjust the toggles if printing is too light on one side or if thick labels are used.

**To position the toggles, complete these steps:**

1. Loosen the locking nuts at the top of the toggle assemblies (Figure 31).

**Figure 30 • Adjusting Toggle Assembly Positions**

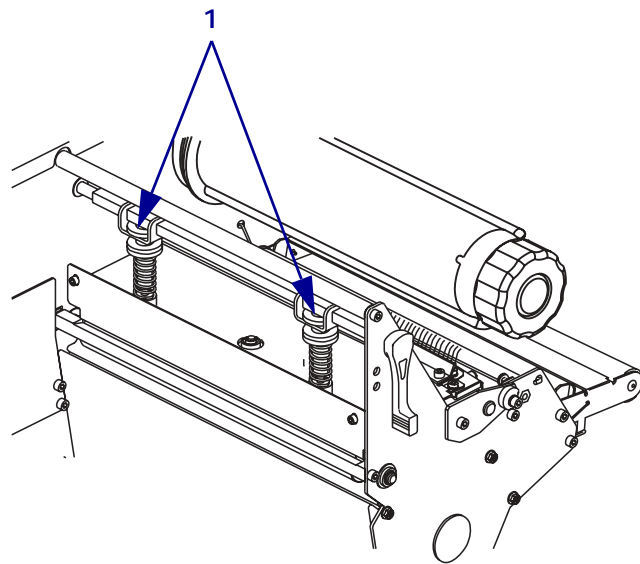

1 Locking nuts

2. Slide the toggles until they provide even pressure on the media. For extremely narrow media, position one toggle over the center of the labels, and decrease the pressure on the unused toggle.
3. Tighten the locking nuts.

## Printhead Pressure Adjustment

If positioning the toggles properly does not solve the problem, adjust printhead pressure. Maximize printhead life by using the lowest pressure that produces the desired print quality.



**Caution** • Observe proper electrostatic safety precautions when handling any static-sensitive components such as circuit boards and printheads.

### To adjust printhead pressure, complete these steps:

1. Print some labels at 2.4 in. (61 mm) per second by running the *PAUSE Self Test* on page 137.
2. While printing labels, use the front panel controls to lower the darkness setting until the labels are printing gray instead of black.
3. Loosen the upper knurled nuts on the toggle assemblies (Figure 31).

**Figure 31 • Adjusting Printhead Pressure**

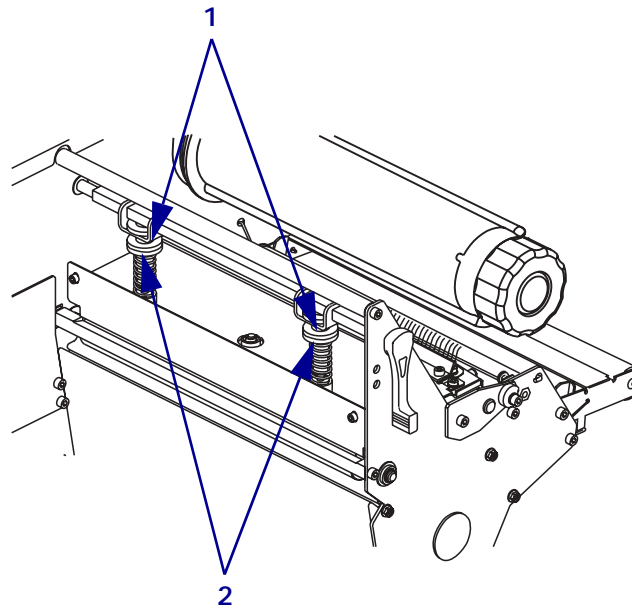

1	Upper knurled nuts
2	Lower knurled nuts

4. Some media types require higher pressure to print well. For these media types, increase or decrease pressure using the lower knurled nuts until the left and right edges of the printed area are equally dark.
5. Increase the darkness level using the front panel controls until the printing is clear.
6. Tighten the upper knurled nuts.



---

# Front Panel Controls

This chapter describes the function of the front panel.

## Contents

Overview .....	42
Enter Setup Mode .....	42
Exit Setup Mode .....	42
Password-Protected Parameters .....	43
Default Password Value .....	43
Disable the Password Protection Feature .....	43
Front Panel LCD .....	44
ZebraNet <sup>®</sup> Wired and Wireless Print Server LCD Displays .....	60
RFID LCD Displays .....	62

## Overview

After you have installed media and ribbon and printed a configuration label, you can change the printer's settings using the front panel controls. For an overview of the front panel, including descriptions of the buttons and lights, see [Front Panel on page 3](#). If you need to restore the printer to its factory default settings, see [FEED and PAUSE Self Test on page 139](#).

Many printer settings may be controlled by your printer's driver or label preparation software. Refer to the driver or software documentation for more information.

## Enter Setup Mode

To enter Setup Mode, complete these steps:

1. Press **SETUP/EXIT** to enter Setup Mode.
2. Press either **NEXT/SAVE** or **PREVIOUS** to scroll through the parameters.

## Exit Setup Mode

To leave Setup Mode, complete these steps:

1. Press **SETUP/EXIT**.  
The LCD displays **SAVE CHANGES**.
2. Press the left or right oval to display the save options ([Table 6](#)).

Table 6 • Save Options When Leaving Setup Mode

LCD Display	Description
PERMANENT	Permanently saves the changes. Values are stored in the printer even when power is turned off.
TEMPORARY	Saves the changes until you change them again or until power is turned off.
CANCEL	Cancels all changes from the time you pressed <b>SETUP/EXIT</b> except the darkness and tear-off settings (if they were changed).
LOAD DEFAULTS	Sets all parameters other than the network settings back to the factory defaults. To see the factory default values, see <a href="#">Front Panel LCD on page 44</a> . <b>Note</b> • Loading factory defaults causes the printer to auto-calibrate.
LOAD LAST SAVE	Loads values from the last permanent save.
DEFAULT NET	Sets the wired and wireless network settings back to factory defaults.

3. Press **NEXT/SAVE** to select the displayed choice.  
When the configuration and calibration sequence is done, **PRINTER READY** displays.

## Password-Protected Parameters

Certain parameters are password-protected by factory default, including the communication parameters.



**Note** • If the parameters are set incorrectly, the printer may function unpredictably.

The first attempt to change a password-protected parameter (pressing one of the ovals) requires you to enter a four-digit password at the **ENTER PASSWORD** display. The left oval changes the selected digit position; the right oval increases the selected digit value. After entering the password, press **NEXT/SAVE**. The parameter you wish to change is displayed. If the password was entered correctly, you can now change the value.

The first time that you attempt to change a password-protected parameter, the printer displays **ENTER PASSWORD**. Before you can change the parameter, you must enter the four-digit password. After you have entered the password correctly, you do not have to enter it again unless you leave Setup Mode by pressing **SETUP/EXIT** or by turning the printer Off (O).

**To Enter a Password for a Password-Protected Parameter, complete these steps:**

1. At the password prompt, use the left oval to change the selected digit position.
2. When you have selected the digit that you wish to change, use the right oval to increase the selected digit value. Repeat these two steps for each digit of the password.
3. After entering the password, press **NEXT/SAVE**.

The parameter you selected to change is displayed. If the password was entered correctly, you can change the value.

### Default Password Value

The default password value is **1234**. The password can be changed using the **^KP** (Define Password) ZPL II instruction or through ZebraLink™ WebView (ZebraNet® PrintServer II required).

### Disable the Password Protection Feature

You can disable the password protection feature so that it no longer prompts you for a password. To do this, set the password to **0000** by sending the ZPL/ZPL II command **^KP0** to the printer. To reenable the password-protection feature, send the command **^KPx**, where **x** can be any number from 1 to 9999.

## Front Panel LCD

Use the LCD display on the front panel to adjust printer settings. The tables in this section show parameters in the order in which they are displayed when you press **NEXT/SAVE** after entering setup mode. Throughout this process, press **NEXT/SAVE** to continue to the next parameter, or press **PREVIOUS** to return to the previous parameter in the cycle.

### Standard LCD Displays

Table 7 lists the standard parameters displayed on all models of this printer. Additional parameters may appear when different options are installed in the printer. See *ZebraNet® Wired and Wireless Print Server LCD Displays on page 60* and *RFID LCD Displays on page 62* for more parameters.

**Table 7 • Standard LCD Displays (Page 1 of 16)**

Parameter	Action/Explanation
DARKNESS	<p><b>Adjusting Print Darkness</b></p> <p>Darkness settings depend on a variety of factors, including ribbon type, labels, and the condition of the printhead. You may adjust the darkness for consistent high-quality printing.</p> <p>If printing is too light, or if there are voids in printed areas, you should increase the darkness. If printing is too dark, or if there is spreading or bleeding of printed areas, you should decrease the darkness. Darkness settings also may be changed by the driver or software settings.</p> <p>The FEED Self Test described in <i>FEED Self Test on page 138</i> can also be used to determine the best darkness setting. Because the darkness setting takes effect immediately, you can see the results on labels that are currently printing.</p> <p><b>Important</b> • Set the darkness to the lowest setting that provides good print quality. If the darkness is set too high, the ink may smear, the ribbon may burn through, or the printhead may wear prematurely.</p> <ul style="list-style-type: none"> <li>• Press the right oval to increase darkness.</li> <li>• Press the left oval to decrease darkness.</li> </ul> <p><b>Default:</b> +4 <b>Range:</b> 0 to +30.0</p>
PRINT SPEED	<p><b>Adjusting Print Speed</b></p> <p>Slower print speeds typically yield better print quality. Print speed changes take effect upon exiting the menu mode.</p> <ul style="list-style-type: none"> <li>• Press the right oval to increase print speed.</li> <li>• Press the left oval to decrease print speed.</li> </ul> <p><b>Default:</b> 2 ips <b>Range:</b> 2 ips to +12 ips (depends on specific printer)</p>



Table 7 • Standard LCD Displays (Page 2 of 16)

Parameter	Action/Explanation
TEAR OFF	<p><b>Adjusting the Tear-Off Position</b></p> <p>This parameter establishes the position of the labels over the tear-off/peel-off bar after printing.</p> <p>Each press of an oval adjusts the tear-off position by four dot rows.</p> <ul style="list-style-type: none"> <li>• Press the right oval to increase value.</li> <li>• Press the left oval to decrease value.</li> </ul> <p><b>Default:</b> +0 <b>Range:</b> –120 to +120</p>
PRINT MODE	<p><b>Selecting Print Mode</b></p> <p>Print mode settings tell the printer the method of label delivery that you wish to use. Be sure to select a print mode that your hardware configuration supports because some of the selections displayed are for optional printer features.</p> <ul style="list-style-type: none"> <li>• Press either oval to display choices.</li> </ul> <p><b>Default:</b> Tear-Off <b>Selections:</b> Tear-Off, Peel-Off, Cutter, Applicator, Rewind <b>Note</b> • Only Tear-Off mode is supported.</p>
MEDIA TYPE	<p><b>Setting Media Type</b></p> <p>This parameter tells the printer the type of media that you are using. Selecting continuous media requires that you include a label length instruction in your label format (^LLxxxx if you are using ZPL or ZPL II).</p> <p>When non-continuous media is selected, the printer feeds media to calculate label length (the distance between two recognized registration points of the inter-label gap, webbing, or alignment notch or hole).</p> <ul style="list-style-type: none"> <li>• Press either oval to display choices.</li> </ul> <p><b>Default:</b> Non-Continuous <b>Selections:</b> Continuous, Non-Continuous</p>
SENSOR TYPE	<p><b>Setting the Sensor Type</b></p> <p>This parameter tells the printer whether you are using media with a web (gap/space between labels, notch, or hole) to indicate the separations between labels or if you are using media with a black mark printed on the back. If your media does not have black marks for registration on the back, leave your printer at the default (web).</p> <ul style="list-style-type: none"> <li>• Press either oval to display other choices.</li> </ul> <p><b>Default:</b> WEB <b>Selections:</b> WEB, MARK</p>

Table 7 • Standard LCD Displays (Page 3 of 16)

Parameter	Action/Explanation
PRINT METHOD	<p><b>Selecting Print Method</b></p> <p>The print method parameter tells the printer the method of printing that you wish to use: direct thermal (no ribbon) or thermal transfer (using thermal transfer media and ribbon).</p> <ul style="list-style-type: none"> <li>• Press either oval to display choices.</li> </ul> <p><b>Default:</b> THERMAL-TRANS.</p> <p><b>Selections:</b> THERMAL-TRANS., DIRECT-THERMAL</p> <p><b>Note</b> • Selecting direct thermal when using thermal transfer media and ribbon creates a printer error condition, but printing continues.</p>
PRINT WIDTH	<p><b>Setting Print Width</b></p> <p>Print width determines the printable area across the width of the label.</p> <p>To change value shown:</p> <ol style="list-style-type: none"> <li>1. Press the left oval to move the cursor.</li> <li>2. Press the right oval to increase the value of the digit.</li> </ol> <p><b>Note</b> • The printer does not accept any value larger than the maximum print width listed in <i>General Specifications on page 144</i>.</p> <p>To change the unit of measurement:</p> <ol style="list-style-type: none"> <li>a. Press the left oval until the unit of measurement is active.</li> <li>b. Press the right oval to toggle to a different unit of measure (mm, inches, or dots).</li> </ol> <p><b>Default Range:</b> The default and range of acceptable values vary depending on the printer. See <i>General Specifications on page 144</i> for further information about the ranges available for your model.</p>
MAXIMUM LENGTH	<p><b>Setting Maximum Length</b></p> <p>Maximum length is used in conjunction with the calibration procedure. The value of this setting is the maximum label length that is used during the media portion of the calibration process. Only a few labels are required to set media sensors. Always set the value that is at least 1 in. (25.4 mm) longer than the longest label to be used on the printer.</p> <ul style="list-style-type: none"> <li>• To increase the value, press the right oval.</li> <li>• To decrease the value, press the left oval.</li> </ul> <p><b>Default Range:</b> The default and range of acceptable values vary depending on your printer's configuration. Values are adjustable in 1 in. (25.4 mm) increments.</p>

Table 7 • Standard LCD Displays (Page 4 of 16)

Parameter	Action/Explanation
EARLY WARNING	<p><b>Setting Early Warning</b></p> <p>When this parameter is enabled, the printer provides warnings when labels or ribbons are running low or when the printhead needs to be cleaned.</p> <p><b>Note</b> • Labels per roll and ribbon length need to be updated when beginning use of the Early Warning System. Also, the printer does not make any adjustments when power is turned off and on.</p> <ul style="list-style-type: none"> <li>• Press the right or left oval to display other choices.</li> </ul> <p><b>Default:</b> MEDIA DISABLED, MAINTENANCE OFF</p> <p><b>Selections:</b> MEDIA DISABLED, MEDIA ENABLED, MAINTENANCE OFF, MAINTENANCE ON</p> <p>To change the Early Warning settings,</p> <ol style="list-style-type: none"> <li>1. When the LCD displays <b>EARLY WARNING</b>, press the right or left oval until the desired setting is listed on the LCD. (If you are prompted for a password, enter your password using the instructions in <a href="#">Password-Protected Parameters on page 43.</a>)</li> <li>2. Press <b>NEXT/SAVE</b> to access the next early warning option.</li> <li>3. Repeat this process to set the early warning for ribbon or maintenance (printhead cleaning).</li> </ol> <p>When the printer detects that less than 15% of the labels or ribbon remain, <b>WARNING MEDIA LOW</b> appears on the LCD. If the alert function has been enabled, an alert is also sent. When the printhead is opened then closed after a media or ribbon warning has been received, the LCD prompts with <b>MEDIA REPLACED?</b>. Press the right oval to select <b>YES</b> to clear the warning and reset the label counter.</p> <p>When setting the Early Warning for maintenance, the LCD prompts <b>HEAD CLEAN?</b>.</p> <ol style="list-style-type: none"> <li>4. Press the right oval to select <b>YES</b>.</li> <li>5. Press <b>SETUP/EXIT</b> to exit setup mode.</li> <li>6. Press <b>NEXT/SAVE</b> to save changes.</li> </ol>
LABELS PER ROLL	<p><b>Setting Labels Per Roll</b></p> <p>This parameter needs to be updated when setting the Early Warning System so the printer can provide early warnings when labels are running low.</p> <ul style="list-style-type: none"> <li>• Press the right or left oval to display other choices.</li> </ul> <p><b>Default:</b> 900 labels</p> <p><b>Range:</b> 100 labels to 9999 labels</p>
LIST FONTS	<p><b>List Fonts</b></p> <ul style="list-style-type: none"> <li>• Press the right oval to print a label that lists the available fonts in the printer, including standard printer fonts plus any optional fonts. Fonts may be stored in RAM, Flash memory, font EPROMs, or font cards.</li> </ul>
LIST BAR CODES	<p><b>List Bar Codes</b></p> <ul style="list-style-type: none"> <li>• Press the right oval to print a label that lists the available bar codes in the printer.</li> </ul>

Table 7 • Standard LCD Displays (Page 5 of 16)

Parameter	Action/Explanation
LIST IMAGES	<p><b>List Images</b></p> <ul style="list-style-type: none"> <li>Press the right oval to print a label that lists the available images stored in the printer's RAM, Flash memory, optional EPROM, or optional memory card.</li> </ul>
LIST FORMATS	<p><b>List Formats</b></p> <ul style="list-style-type: none"> <li>Press the right oval to print a label that lists the available formats stored in the printer's RAM, Flash memory, optional EPROM, or optional memory card.</li> </ul>
LIST SETUP	<p><b>List Setup</b></p> <ul style="list-style-type: none"> <li>Press the right oval to print a label that lists the current printer configuration. (Same label as shown in <i>Print a Printer Configuration Label on page 32.</i>)</li> </ul>
LIST NETWORK	<p><b>List Network Settings</b></p> <p>This selection is used to print a network configuration label, which lists the settings for the wired ZebraNet PrintServer II (PSII) and the ZebraNet Wireless Print Server (if installed).</p> <ul style="list-style-type: none"> <li>Press the right oval to print a label that lists the current network configuration. (Same label as shown in <i>Print a Network Configuration Label on page 34.</i>)</li> </ul>
LIST ALL	<p><b>List All</b></p> <ul style="list-style-type: none"> <li>Press the right oval to print labels that list the available fonts, bar codes, images, formats, and the current printer and network configurations.</li> </ul>
FORMAT CARD A:                B:	<p><b>Format Memory Card</b></p> <p><b>Caution</b> • Perform this operation only when it is necessary to erase all previously stored information from the memory card.</p> <ol style="list-style-type: none"> <li>When the LCD displays <b>INITIALIZE CARD</b>, press the left oval to select the A memory (internal CompactFlash) or the right oval to select B memory (PCMCIA card). (If you are prompted for a password, enter your password using the instructions in <i>Password-Protected Parameters on page 43.</i>) The front panel LCD asks <b>ARE YOU SURE?</b></li> <li>Do you wish to continue?           <ul style="list-style-type: none"> <li>Press the left oval to select <b>NO</b> to cancel the request and return to <b>INITIALIZE CARD</b> prompt.</li> <li>Press the right oval to select <b>YES</b> and begin initialization. <b>FORMATTING CARD</b> displays. When formatting is complete, <b>INITIALIZE CARD</b> displays.</li> </ul> </li> </ol> <p><b>Note</b> • Depending on the amount of memory in the memory card, initialization may take up to three minutes to complete.</p>

Table 7 • Standard LCD Displays (Page 6 of 16)

Parameter	Action/Explanation												
INIT FLASH MEM	<p><b>Initialize Flash Memory</b></p> <p><b>Caution</b> • Perform this operation only when it is necessary to erase all previously stored information from Flash memory.</p> <ol style="list-style-type: none"> <li>When the LCD displays <b>INITIALIZE CARD</b>, press the right oval to select <b>YES</b>. (If you are prompted for a password, enter your password using the instructions in <a href="#">Password-Protected Parameters on page 43</a>.) The LCD asks <b>INITIALIZE FLASH</b>.</li> <li>Press the right oval to select <b>YES</b>. The LCD asks <b>ARE YOU SURE?</b>.</li> <li>Do you wish to continue? <ul style="list-style-type: none"> <li>Press the left oval to select <b>NO</b> to cancel the request and return to the <b>INIT FLASH MEM</b> prompt.</li> <li>Press the right oval to select <b>YES</b> and begin initialization. When formatting is complete, <b>INIT FLASH MEM</b> displays.</li> </ul> </li> </ol>												
SENSOR PROFILE	<p><b>Sensor Profile</b></p> <p>The media sensor profile may be used to troubleshoot registration problems that may be caused when the media sensor detects preprinted areas on the media or experiences difficulty in determining web location.</p> <ul style="list-style-type: none"> <li>Press the right oval to start this standard calibration procedure and print a media sensor profile.</li> </ul> <p><a href="#">Figure 32</a> shows a media sensor profile. If the sensitivity of the media and/or ribbon sensors must be adjusted, use <a href="#">Calibrate Media and Ribbon Sensors on page 50</a> to adjust the media and ribbon sensor sensitivity.</p> <p style="text-align: center;"><b>Figure 32 • Media Sensor Profile</b></p>  <table border="1" data-bbox="630 1276 1271 1507"> <caption>Data for Figure 32: Media Sensor Profile</caption> <thead> <tr> <th>Sensor</th> <th>Reading 1</th> <th>Reading 2</th> </tr> </thead> <tbody> <tr> <td>RIBBON</td> <td>0.85</td> <td>0.85</td> </tr> <tr> <td>MEDIA</td> <td>0.20</td> <td>0.55</td> </tr> <tr> <td>WEB</td> <td>0.55</td> <td>0.55</td> </tr> </tbody> </table>	Sensor	Reading 1	Reading 2	RIBBON	0.85	0.85	MEDIA	0.20	0.55	WEB	0.55	0.55
Sensor	Reading 1	Reading 2											
RIBBON	0.85	0.85											
MEDIA	0.20	0.55											
WEB	0.55	0.55											

Table 7 • Standard LCD Displays (Page 7 of 16)

Parameter	Action/Explanation
<p><b>MEDIA AND RIBBON CALIBRATE</b></p>	<p><b>Calibrate Media and Ribbon Sensors</b> Use this procedure to adjust sensitivity of media and ribbon sensors.</p> <p><b>Important</b> • This procedure must be followed exactly as presented. All of the steps must be performed even if only one of the sensors requires adjustment. You may press the left oval at any step in this procedure to cancel the procedure.</p> <ol style="list-style-type: none"> <li>1. Press the right oval to start the calibration procedure. The <b>LOAD BACKING</b> prompt displays.</li> <li>2. Open the printhead.</li> <li>3. Remove approximately 8 in. (203 mm) of labels from the backing, and pull the media into the printer so that only the backing is between the media sensors.</li> <li>4. Leave the printhead open.</li> <li>5. Press the right oval to continue. The <b>REMOVE RIBBON</b> prompt displays.</li> <li>6. Remove the ribbon.</li> <li>7. Close the printhead.</li> <li>8. Press the right oval to continue. The message <b>CALIBRATING PLEASE WAIT</b> displays. The printer adjusts the scale (gain) of the signals that it receives from the media and ribbon sensors. On the sensor profile, this essentially corresponds to moving the peak of the graph up or down to optimize the readings for your application. When calibration is complete, <b>RELOAD ALL</b> displays.</li> <li>9. Open the printhead and pull the media forward until a label is positioned under the media sensor.</li> <li>10. Reload the ribbon.</li> <li>11. Close the printhead.</li> <li>12. Press the right oval to continue. The printer does a calibration equivalent to pressing <b>CALIBRATE</b>; during this process, the printer determines the label length. To see the new readings on the new scale, print a sensor profile.</li> </ol>
<p><b>PARALLEL COMM</b></p>	<p><b>Setting Parallel Communications</b> Select the communications port that matches the one being used by the host computer.</p> <ul style="list-style-type: none"> <li>• Press the right or left oval to display other choices.</li> </ul> <p><b>Default:</b> BIDIRECTIONAL <b>Selections:</b> BIDIRECTIONAL, UNIDIRECTIONAL, OR TWINAX/COAX</p>
<p><b>SERIAL COMM</b></p>	<p><b>Setting Serial Communications</b> Select the communications port that matches the one being used by the host computer.</p> <ul style="list-style-type: none"> <li>• Press the right or left oval to display other choices.</li> </ul> <p><b>Default:</b> RS-232 <b>Selections:</b> RS-232, RS-422/485, RS485MULTIDROP</p>

Table 7 • Standard LCD Displays (Page 8 of 16)

Parameter	Action/Explanation
BAUD	<p><b>Setting Baud</b></p> <p>The baud setting of the printer must match the baud setting of the host computer for accurate communications to take place. Select the value that matches the one being used by the host computer.</p> <ul style="list-style-type: none"> <li>• Press the right or left oval to display other choices.</li> </ul> <p><b>Default:</b> 9600 <b>Selections:</b> 110, 300, 600, 1200, 2400, 4800, 9600, 14400, 19200, 28800, 38400, 57600, 115200</p>
DATA BITS	<p><b>Setting Data Bits</b></p> <p>The data bits of the printer must match the data bits of the host computer for accurate communications to take place. Set the data bits to match the setting being used by the host computer.</p> <p><b>Note</b> • Code Page 850 requires the data bits to be set to 8 bits.</p> <ul style="list-style-type: none"> <li>• Press the right or left oval to display other choices.</li> </ul> <p><b>Default:</b> 8 BITS <b>Selections:</b> 7 BITS, 8 BITS</p>
PARI TY	<p><b>Setting Parity</b></p> <p>The parity of the printer must match the parity of the host computer for accurate communications to take place. Select the parity that matches the one being used by the host computer.</p> <ul style="list-style-type: none"> <li>• Press the right or left oval to display other choices.</li> </ul> <p><b>Default:</b> NONE <b>Selections:</b> NONE, ODD, EVEN</p>
HOST HANDSHAKE	<p><b>Setting Host Handshake</b></p> <p>The handshake protocol of the printer must match the handshake protocol of the host computer for proper communications to take place. Select the handshake protocol that matches the one being used by the host computer.</p> <ul style="list-style-type: none"> <li>• Press the right or left oval to display other choices.</li> </ul> <p><b>Default:</b> XON/XOFF <b>Selections:</b> XON/XOFF, DSR/DTR, RTS/CTS</p>
PROTOCOL	<p><b>Setting Protocol</b></p> <p>Protocol is a type of error checking system. Depending on the selection, an indicator may be sent from the printer to the host computer signifying that data has been received. Select the protocol that is requested by the host computer. Further details on protocol can be found in the <i>ZPL II Programming Guide</i>.</p> <ul style="list-style-type: none"> <li>• Press the right or left oval to display other choices.</li> </ul> <p><b>Default:</b> NONE <b>Selections:</b> NONE, ZEBRA, ACK_NAK</p> <p><b>Note</b> • Zebra is the same as ACK_NAK, except that Zebra response messages are sequenced. If Zebra is selected, the printer must use <b>DSR/DTR</b> host handshake protocol.</p>

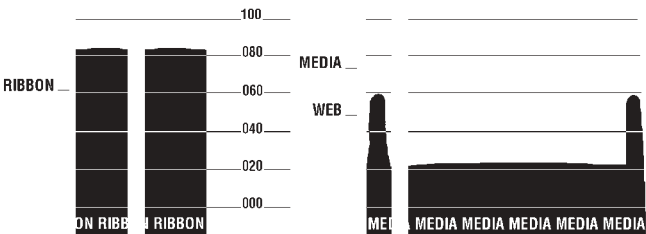
Table 7 • Standard LCD Displays (Page 9 of 16)

Parameter	Action/Explanation
NETWORK ID	<p><b>Setting Network ID</b></p> <p>Network ID is used to assign a unique number to a printer used in an RS-422/RS-485 network. This gives the host computer the means to address a specific printer. If the printer is used in an RS-422/RS-485 network, you must select a network ID number. This does not affect TCP/IP or IPX networks.</p> <ol style="list-style-type: none"> <li>1. Press the left oval to move to the next digit position.</li> <li>2. Press the right oval to increase the value of the digit.</li> </ol> <p><b>Default:</b> 000 <b>Range:</b> 000 to 999</p>
COMMUNICATIONS	<p><b>Setting Communications Mode</b></p> <p>The communication diagnostics mode is a troubleshooting tool for checking the interconnection between the printer and the host computer. When <b>DIAGNOSTICS</b> is selected, all data sent from the host computer to the printer is printed as straight ASCII characters, with the hex value below the ASCII text. The printer prints all characters received, including control codes, like CR (carriage return). A sample printout is shown in <i>Communications Diagnostics Test</i> on page 139.</p> <p><b>Notes</b> on diagnostic printouts are:</p> <ul style="list-style-type: none"> <li>• FE indicates a framing error.</li> <li>• OE indicates an overrun error.</li> <li>• PE indicates a parity error.</li> <li>• NE indicates noise.</li> </ul> <ol style="list-style-type: none"> <li>1. Press the right or left oval to toggle between the choices.</li> <li>2. For any errors, check that your communication parameters are correct.</li> <li>3. Set the print width equal to or less than the label width used for the test. See <i>Label Specifications</i> on page 148 for more information.</li> </ol> <p><b>Default:</b> NORMAL MODE <b>Selections:</b> NORMAL MODE, DIAGNOSTICS</p>
CONTROL PREFIX	<p><b>Control Prefix Character</b></p> <p>The printer looks for this two-digit hex character to indicate the start of a ZPL/ZPL II control instruction.</p> <p><b>Note</b> • Do not use the same hex value for the control, format, and delimiter character. The printer must see different characters to work properly.</p> <ol style="list-style-type: none"> <li>1. Press the left oval to move to the next digit position.</li> <li>2. Press the right oval to increase the value of the digit.</li> </ol> <p><b>Default:</b> 7E (tilde—displayed as a black square) <b>Range:</b> 00 to FF</p>



Table 7 • Standard LCD Displays (Page 10 of 16)

Parameter	Action/Explanation
FORMAT PREFIX	<p><b>Format Prefix Character</b></p> <p>The format prefix is a two-digit hex value used as a parameter place marker in ZPL/ZPL II format instructions. The printer looks for this hex character to indicate the start of a ZPL/ZPL II format instruction. See the <i>ZPL II Programming Guide Volume I</i> for more information.</p> <p><b>Note</b> • Do <b>not</b> use the same hex value for the control, format, and delimiter character. The printer must see different characters to work properly.</p> <ol style="list-style-type: none"> <li>1. Press the left oval to move to the next digit position.</li> <li>2. Press the right oval to increase the value of the digit.</li> </ol> <p><b>Default:</b> 5E (caret) <b>Range:</b> 00 to FF</p>
DELIMITER CHAR	<p><b>Delimiter Character</b></p> <p>The delimiter character is a two-digit hex value used as a parameter place marker in ZPL/ZPL II format instructions. See the <i>ZPL II Programming Guide Volume I</i> for more information.</p> <p><b>Note</b> • Do <b>not</b> use the same hex value for the control, format, and delimiter character. The printer must see different characters to work properly.</p> <ol style="list-style-type: none"> <li>1. Press the left oval to move to the next digit position.</li> <li>2. Press the right oval to increase the value of the digit.</li> </ol> <p><b>Default:</b> 2C (comma) <b>Range:</b> 00 to FF</p>
ZPL MODE	<p><b>Selecting ZPL Mode</b></p> <p>The printer remains in the selected mode until it is changed by this front panel instruction or by using a ZPL/ZPL II command. The printer accepts label formats written in either ZPL or ZPL II, eliminating the need to rewrite any ZPL formats that already exist. See the <i>ZPL II Programming Guide</i> for more information on the differences between ZPL and ZPL II.</p> <ul style="list-style-type: none"> <li>• Press the right or left oval to display other choices.</li> </ul> <p><b>Default:</b> ZPL II <b>Selections:</b> ZPL II, ZPL</p>

Table 7 • Standard LCD Displays (Page 11 of 16)



Parameter	Action/Explanation
<p><b>MEDIA POWER UP</b></p>	<p><b>Media Power Up</b> This parameter sets the action of the labels when the printer is turned on.</p> <ul style="list-style-type: none"> <li>• Press the right or left oval to display the choices.</li> </ul> <p> <b>Note</b> • For best results with RFID labels, set this parameter to FEED or LENGTH.</p> <p><b>Default:</b> CALIBRATION</p> <p><b>Selections:</b></p> <ul style="list-style-type: none"> <li>• <b>FEED</b>—feeds the labels to the first registration point.</li> <li>• <b>CALIBRATION</b>—determines the length of the label and adjusts the sensor settings.</li> <li>• <b>LENGTH</b>—In continuous mode, feeds the last stored label length. In non-continuous mode, calibrates based on the maximum label length setting (see <i>Setting Maximum Length</i> on page 46).</li> <li>• <b>SHORT CAL</b>—calibrates label length using the current sensor settings.</li> <li>• <b>NO MOTION</b>—the media does not move. You must press <b>FEED</b> to cause the printer to resynch to the start of the next label.</li> </ul>
<p><b>HEAD CLOSE</b></p>	<p><b>Head Close</b> This parameter sets the action of the labels when the printhead is closed.</p> <ul style="list-style-type: none"> <li>• Press the right or left oval to display the choices.</li> </ul> <p> <b>Note</b> • For best results with RFID labels, set this parameter to FEED or LENGTH.</p> <p><b>Default:</b> CALIBRATION</p> <p><b>Selections:</b></p> <ul style="list-style-type: none"> <li>• <b>FEED</b>—feeds the labels to the first registration point.</li> <li>• <b>CALIBRATION</b>—determines the length of the label and adjusts the sensor settings.</li> <li>• <b>LENGTH</b>—In continuous mode, feeds the last stored label length. In non-continuous mode, calibrates based on the maximum label length setting (see <i>Setting Maximum Length</i> on page 46).</li> <li>• <b>SHORT CAL</b>—calibrates label length using the current sensor settings.</li> <li>• <b>NO MOTION</b>—the media does not move. You must press <b>FEED</b> to cause the printer to resynch to the start of the next label.</li> </ul>

Table 7 • Standard LCD Displays (Page 12 of 16)

Parameter	Action/Explanation
BACKFEED	<p><b>Backfeed Sequence</b></p> <p>This parameter establishes when and how much label backfeed occurs after a label is removed or cut in Peel-Off, Cutter, and Applicator modes. It has no effect in Rewind or Tear-Off modes. This parameter setting can be superseded by the <code>~JS</code> instruction when received as part of a label format (see the <i>ZPL II Programming Guide</i>).</p> <p><b>Note</b> • The difference between the value entered and 100% establishes how much backfeed occurs before the next label prints. For example, a value of 40 means that 40% of the backfeed takes place after the label is removed or cut. The remaining 60% takes place before the next label prints. A value of <b>BEFORE</b> means that all backfeed takes place before the next label prints.</p> <ul style="list-style-type: none"> <li>• Press the right or left oval to display other choices.</li> </ul> <p><b>Default:</b> DEFAULT (90%)</p> <p><b>Selections:</b> DEFAULT, AFTER, OFF, BEFORE, 10%, 20%, 30%, 40%, 50%, 60%, 70%, 80%</p>
LABEL TOP	<p><b>Adjusting Label Top Position</b></p> <p>The label top position adjusts the print position vertically on the label. Positive numbers adjust the label top position further down the label (away from the printhead), negative numbers adjust the position up the label (toward the printhead). The displayed value represents dots.</p> <ul style="list-style-type: none"> <li>• To increase the value, press the right oval.</li> <li>• To decrease the value, press the left oval.</li> </ul> <p><b>Default:</b> +0</p> <p><b>Range:</b> –120 to +120 dot rows</p>
LEFT POSITION	<p><b>Adjusting Left Position</b></p> <p>This parameter establishes how far from the left edge of a label the format begins to print by adjusting horizontal positioning on the label. Positive numbers adjust the printing to the left by the number of dots selected; negative numbers shift printing to the right.</p> <p>The displayed value represents dots.</p> <ol style="list-style-type: none"> <li>1. Press the left oval to move the cursor.</li> <li>2. Press the right oval to change between + and to increase the value of the digit.</li> <li>3. For a negative value, enter the value before changing to the minus sign.</li> </ol> <p><b>Default:</b> 0000</p> <p><b>Range:</b> –9999 to +9999</p>

Table 7 • Standard LCD Displays (Page 13 of 16)

Parameter	Action/Explanation
HEAD TEST COUNT	<p><b>Setting the Head Test Count</b></p> <p>The printer periodically performs a test of the printhead functionality, called a <b>printhead test</b> or <b>head test</b>. This parameter establishes how many labels are printed between these internal tests.</p> <ol style="list-style-type: none"> <li>1. Press the left oval to move to the next digit position.</li> <li>2. Press the right oval to increase the value of the digit.</li> </ol> <p><b>Default:</b> 0000 (disables the test) <b>Range:</b> 0000 to 9999</p>
HEAD RESISTOR	<p><b>Setting the Head Resistor Value</b></p> <p><b>Caution</b> • This parameter should be changed only by qualified service personnel. Do <b>not</b> set the value higher than that shown on the printhead. Setting a higher value may damage the printhead.</p> <p>This value has been preset at the factory to match the resistance value of the printhead. It does not need to be changed unless the printhead or the main logic board is replaced.</p> <ol style="list-style-type: none"> <li>1. Look on the printhead for the label that shows the resistance value (<math>\Omega</math> value).</li> <li>2. Press the left oval to move to the next digit position.</li> <li>3. Press the right oval to increase the value of the digit.</li> </ol> <p><b>Initial Value:</b> Factory-set to match the printhead shipped with your printer. <b>Default Value:</b> 0500 <b>Range:</b> 0500 to 2500</p>
VERIFIER PORT	<p><b>Setting the Verifier Port</b></p> <p>The auxiliary port is used to determine how the printer reacts to the online verifier. The three operating conditions for this port are:</p> <ul style="list-style-type: none"> <li>• <b>OFF:</b> The verifier port is off.</li> <li>• <b>VER-RPRNT ERR:</b> Label reprinted if verifier detects an error. If a bar code is near the upper edge of the label, the label is fed out far enough to be verified and then backfed to allow the next label to print and be verified.</li> <li>• <b>VER-THRUPUT:</b> Allows greatest throughput but may not indicate a verification error immediately upon detection. May print from one to three labels before an error is recognized and printing stops.</li> </ul> <p>• Press the right or left oval to display other choices.</p> <p><b>Default:</b> OFF <b>Selections:</b> OFF, VER-RPRNT, VER-THRUPUT</p> <p>For more information on the operation of the optional verifier, see the documentation provided with that option.</p>

Table 7 • Standard LCD Displays (Page 14 of 16)

Parameter	Action/Explanation
APPLICATOR PORT	<p><b>Setting the Applicator Port</b> Determines the action of the applicator port.</p> <p><b>Note</b> • Set this value as suggested by the applicator manufacturer.</p> <ul style="list-style-type: none"> <li>• <b>Off:</b> The applicator port is off.</li> <li>• <b>Mode 1:</b> Asserts the <b>~END_PRINT</b> signal low while the printer is moving the label forward.</li> <li>• <b>Mode 2:</b> Asserts the <b>~END_PRINT</b> signal high while the printer is moving the label forward.</li> <li>• <b>Mode 3:</b> Asserts the <b>~END_PRINT</b> signal low for 20 milliseconds when a label has been completed and positioned. Not asserted during continuous printing modes.</li> <li>• <b>Mode 4:</b> Asserts the <b>~END_PRINT</b> signal high for 20 milliseconds when a label has been completed and positioned. Not asserted during continuous printing modes.</li> </ul> <p>• Press the right or left oval to display other choices.</p> <p><b>Default:</b> OFF <b>Selections:</b> OFF, MODE 1, MODE 2, MODE 3, MODE 4</p>
START PRINT SIG	<p><b>Start Print Signal</b> This parameter determines how the printer reacts to the Start Print Signal input on pin 3 of the applicator interface connector at the rear of the printer.</p> <ul style="list-style-type: none"> <li>• In <b>Pulse Mode</b>, labels print when the signal transitions from HIGH to LOW.</li> <li>• In <b>Level Mode</b>, labels print as long as the signal is asserted LOW.</li> </ul> <p><b>Caution</b> • Start Print Signal is set by the applicator manufacturer and should not be changed unless the factory defaults have been reloaded. The printer must be returned to its designated setting for it to work properly.</p> <p>• Press the right or left oval to display other choices.</p> <p><b>Default:</b> PULSE MODE <b>Selections:</b> PULSE MODE, LEVEL MODE</p>

Table 7 • Standard LCD Displays (Page 15 of 16)

Parameter	Action/Explanation
RESYNCH MODE	<p><b>Resynch Mode</b></p> <p>This parameter determines how the printer reacts if the label synchronization is lost and the label top is not where expected.</p> <ul style="list-style-type: none"> <li>• <b>Feed Mode</b>—If the label top is not where expected, the printer feeds a blank label to find the label top position.</li> <li>• <b>Error Mode</b>—If the label top is not where expected, the printer stops, enters Pause Mode, displays the message <b>Error Condition Feed Label</b>, flashes the <b>ERROR</b> light, and asserts the Service Required signal (pin 10 on the Applicator Interface Connector).</li> </ul> <p>To resynch the media to the top of the label in Error Mode, press <b>PAUSE</b> to exit Pause Mode. The <b>ERROR</b> light stops flashing, and the Service Required signal is deactivated. The action of the printer is determined by the <b>Head Close</b> configuration selection (see <a href="#">Head Close on page 54</a>).</p> <ul style="list-style-type: none"> <li>• Press the right or left oval to toggle between choices.</li> </ul> <p><b>Default:</b> FEED MODE <b>Selections:</b> FEED MODE, ERROR MODE</p>
WEB S.	<p>These parameters are automatically set during the calibration procedure. They should be changed only by a qualified service technician. See the <i>Maintenance Manual</i> for more information on these parameters.</p> <ul style="list-style-type: none"> <li>• Press <b>NEXT/SAVE</b> to scroll through these parameters.</li> </ul>
MEDIA S.	
RIBBON S.	
TAKE LABEL	
MARK S.	
MARK MED S.	
MEDIA LED	
RIBBON LED	
MARK LED	
LCD ADJUST	<p><b>Adjust LCD Contrast</b></p> <p>This parameter allows you to adjust the contrast of your LCD if it is difficult to read.</p> <ol style="list-style-type: none"> <li>1. Press the left oval to move the cursor.</li> <li>2. Press the right oval to toggle +/- or to increase the value of the digit.</li> </ol> <p><b>Range:</b> 00 to 19</p>
FORMAT CONVERT	<p><b>Select Format Conversion Factor</b></p> <p>Selects the bitmap scaling factor. The first number is the original dots per inch (dpi) value; the second, the dpi to which you would like to scale.</p> <p><b>Note</b> • Not applicable on all printers.</p> <ul style="list-style-type: none"> <li>• Press the right or left oval to display other choices.</li> </ul> <p><b>Default:</b> None <b>Selections:</b> None, 150 → 300, 150 → 600, 200 → 600, 300 → 600</p>

Table 7 • Standard LCD Displays (Page 16 of 16)

Parameter	Action/Explanation
IDLE DISPLAY	<p><b>Select Idle Display</b> This parameter selects the LCD options for the real-time clock.</p> <p><b>Note</b> • If the default value is not selected, pressing either oval briefly displays the firmware version of the printer.</p> <ul style="list-style-type: none"> <li>• Press the right or left oval to display other choices.</li> </ul> <p><b>Default:</b> FW (firmware) VERSION <b>Selections:</b> FW VERSION, MM/DD/YY (24 HR), MM/DD/YY (12 HR), DD/MM/YY (24 HR), DD/MM/YY (12 HR)</p>
RTC DATE	<p><b>Set RTC (Real-time clock) Date</b> This parameter allows you to set the date following the convention selected in IDLE DISPLAY.</p> <ol style="list-style-type: none"> <li>1. Press the left oval to move to the next digit position.</li> <li>2. Press the right oval to change the value of the digit.</li> </ol>
RTC TIME	<p><b>Set RTC (Real-time clock) Time</b> This parameter allows you to set the time following the convention selected in IDLE DISPLAY.</p> <ol style="list-style-type: none"> <li>1. Press the left oval to move to the next digit position.</li> <li>2. Press the right oval to change the value of the digit.</li> </ol>
LANGUAGE	<p><b>Selecting the Display Language</b> This parameter allows you to change the language used on the LCD.</p> <ul style="list-style-type: none"> <li>• Press the right or left oval to display other choices.</li> </ul> <p><b>Default:</b> ENGLISH <b>Selections:</b> ENGLISH, SPANISH, FRENCH, GERMAN, ITALIAN, NORWEGIAN, PORTUGUESE, SWEDISH, DANISH, SPANISH 2, DUTCH, FINNISH, JAPANESE</p>

## ZebraNet® Wired and Wireless Print Server LCD Displays

The menu options shown in [Table 8](#) display only if you have the ZebraNet PrintServer II, or 10/100 PrintServer, or Wireless Print Server installed.

**Table 8 • Print Server LCD Displays**

Parameter	Action/Explanation
LOAD LAN FROM? <sup>1</sup>	This parameter, which serves the same function as the ^NP ZPL command, specifies whether to use the printer's or the print server's IP settings at bootup. <i>Accepted Values:</i> PRINTER, PRINTSERVER <i>Default Value:</i> PRINTER
WIRED PS CHECK? <sup>1</sup>	This parameter, which serves the same function as the ^NB ZPL command, tells the printer whether to search for a wired print server at bootup. <i>Accepted Values:</i> YES, NO <i>Default Value:</i> NO
IP PROTOCOL <sup>2</sup>	<b>IP Protocol</b> Allows either the user (permanent) or the server (dynamic) to select the IP address. If a dynamic option is chosen, this selection determines the method(s) by which the print server receives the IP address from the server. <ul style="list-style-type: none"> <li>Press the right or left oval to display other choices.</li> </ul> <b>Default:</b> ALL <b>Selections:</b> ALL, GLEANING ONLY, RARP, BOOTP, DHCP, DHCP AND BOOTP, PERMANENT <b>Note •</b> Use of GLEANING ONLY is not recommended when the Wireless Print Server is installed.
IP ADDRESS <sup>2</sup>	<b>IP Address</b> This parameter allows you to select the IP address if PERMANENT was chosen in IP PROTOCOL. (If a dynamic option was chosen, the user cannot select the address.) <ol style="list-style-type: none"> <li>Press the left oval to move to the next digit position.</li> <li>Press the right oval to increase the value of the digit.</li> </ol>
SUBNET MASK <sup>2</sup>	<b>Subnet Mask</b> This parameter selects the part of the IP address that is considered to be part of the local network. It can be reached without going through the default gateway. <ol style="list-style-type: none"> <li>Press the left oval to move to the next digit position.</li> <li>Press the right oval to increase the value of the digit.</li> </ol>

1 Appears only when the ZebraNet Wireless Print Server is installed.

2 These parameters appear after the system recognizes the existence of a ZebraNet print server (wired or wireless). After the print server is recognized, all zeroes (000.000.000.000) will display until the printer obtains an IP address or defaults to address 192.168.254.254.

3 If a wireless password is set, you must enter the wireless password (not the printer password) to access this parameter.

4 This parameter appears 1) when no wireless card is inserted or 2) when the wireless card is associated to the WLAN and the card supports LEAP.



Table 8 • Print Server LCD Displays (Continued)

Parameter	Action/Explanation
DEFAULT GATEWAY <sup>2</sup>	<p><b>Default Gateway</b></p> <p>This parameter allows you to select the IP address that the network traffic is routed through if the destination address is not part of the local network.</p> <ol style="list-style-type: none"> <li>1. Press the left oval to move to the next digit position.</li> <li>2. Press the right oval to increase the value of the digit.</li> </ol>
MAC ADDRESS <sup>1,3</sup>	<p><b>MAC Address</b></p> <p>This parameter cannot be changed through the front panel.</p>
ESSID <sup>1,3</sup>	<p><b>ESSID</b></p> <p>This parameter cannot be changed through the front panel.</p>
AUTH. TYPE <sup>1,3</sup>	<p><b>Authentication Type</b></p> <p><b>Default:</b> OPEN</p> <p><b>Selections:</b> OPEN, SHARED</p>
LEAP MODE <sup>3,4</sup>	<p>An encryption method that is available with some wireless cards. Set the LEAP user name and password through the printer web pages.</p> <p><i>Accepted Values:</i> ON, OFF</p> <p><i>Default Value:</i> OFF</p>
ENCRYPTION MODE <sup>1,3</sup>	<p><b>Encryption Mode</b></p> <p><b>Default:</b> OFF</p> <p><b>Selections:</b> OFF, 40-BIT, 128-BIT</p>
ENCRYPTION INDEX <sup>1,3</sup>	<p><b>Encryption Index</b></p> <p><b>Default:</b> 1</p> <p><b>Selections:</b> 1, 2, 3, 4</p>
RESET NETWORK <sup>2,3</sup>	<p><b>Reset Network</b></p> <p>This option resets the wireless card and the print server when the wireless option is running. Selecting this option has no effect when the wireless option is not running, when there is no card inserted, or when the wireless password is anything other than the default (zero).</p> <ol style="list-style-type: none"> <li>1. Press the right oval to select <b>YES</b>.</li> </ol> <p>The LCD prompts <b>ARE YOU SURE?</b></p> <ul style="list-style-type: none"> <li>• Press the left oval to select <b>NO</b> to cancel the request.</li> <li>• Press the right oval to select <b>YES</b> and reset the network.</li> </ul>

1 Appears only when the ZebraNet Wireless Print Server is installed.

2 These parameters appear after the system recognizes the existence of a ZebraNet print server (wired or wireless). After the print server is recognized, all zeroes (000.000.000.000) will display until the printer obtains an IP address or defaults to address 192.168.254.254.

3 If a wireless password is set, you must enter the wireless password (not the printer password) to access this parameter.

4 This parameter appears 1) when no wireless card is inserted or 2) when the wireless card is associated to the WLAN and the card supports LEAP.

## RFID LCD Displays

The menu options shown in [Table 9](#) display only if you have a Radio Frequency Identification (RFID) reader installed.

**Table 9 • RFID LCD Displays**

Parameter	Action/Explanation		
<p>RFID TEST QUI CK SLOW</p>	<p><b>Perform RFID Test</b></p> <p>In both versions of this test, the printer attempts to read and write to a transponder. In the slow test, the printer also checks the reader version number. If the printer fails the test, the front panel displays an error message. No label movement occurs with this test.</p> <ol style="list-style-type: none"> <li>1. Position an RFID label so that the transponder is over the antenna support.</li> <li>2. Press the left oval to select <b>QUI CK</b>. OR Press the right oval to select <b>SLOW</b>.</li> <li>3. If necessary, press the right arrow to select <b>CONTI NUE</b>.</li> </ol> <p style="text-align: center;"><b>Figure 33 • Antenna Support Location</b></p>  <table border="1" style="margin-left: auto; margin-right: auto;"> <tr> <td style="text-align: center; width: 30px;">1</td> <td>Antenna support</td> </tr> </table>	1	Antenna support
1	Antenna support		

Table 9 • RFID LCD Displays (Continued)

Parameter	Action/Explanation
RFID TAG CALIB RESTORE RUN	<p><b>Calibrate RFID Tag</b></p> <p>This option allows you to have the printer determine the optimum programming position for a given label or to bypass this function and use a default position if the media conforms to Zebra’s placement requirements. An auto-calibration occurs after this tag calibration to realign the media to its proper rest position and to update the media tracking values in the printer.</p> <ol style="list-style-type: none"> <li>1. Place an RFID label over the reader (no movement occurs with the test).</li> <li>2. Press the left oval to select <b>RESTORE</b>. OR Press the right oval to select <b>RUN</b>.</li> </ol> <ul style="list-style-type: none"> <li>• <b>RESTORE</b>—Selecting this option resets the programming position to the label length minus 1 mm (0.04 in.).</li> <li>• <b>RUN</b>—This option performs an RFID transponder calibration for a specific RFID label. The printer feeds the RFID label one dot-row at a time while taking readings (via the READ TAG command and the WRITE TAG commands) to profile the RFID transponder. Based on the results, the printer determines the optimum programming position for the label. The calibrated value is used as the programming position for the ^RS command, can be overwritten by the ^RS command, and is saved to nonvolatile memory (the value is saved even if the power is turned off).  This calibration takes into account the print mode, backfeed mode, and tear off position. The ^HR ZPL command performs the same calibration and returns a results table to the host.</li> </ul>
RFID READ PWR	<p><b>View or Change RFID Read Power</b></p> <p>This parameter displays the current value for RFID read power. <b>Selections:</b> HI, MED, LOW <b>Default:</b> HI</p>
RFID WRITE PWR	<p><b>View or Change RFID Write Power</b></p> <p>This parameter displays the current value for RFID write power. <b>Selections:</b> HI, MED, LOW <b>Default:</b> HI</p>
RFID ERR STATUS	<p><b>RFID Error Status</b></p> <p>If an error condition exists, a message may be displayed here.</p>
RFID TAG TYPE	<p><b>Specify RFID Tag Type</b></p> <p><b>Selections:</b></p> <ul style="list-style-type: none"> <li>• CLASS 1 64-BIT</li> <li>• CLASS 1 96-BIT</li> <li>• ISO18000</li> <li>• NONE</li> <li>• CLASS 0</li> <li>• CLASS 0+</li> </ul> <p><b>Default:</b> CLASS 1 96-BIT</p>

Table 9 • RFID LCD Displays (Continued)

Parameter	Action/Explanation
RFID TAG DATA	<p><b>Read and Display RFID Tag Data</b></p> <p>When this option is selected, the reader attempts to read a tag over the reader, even if the printhead is open. If no tag data can be read, the text <b>NO DATA</b> appears on the bottom line of the display.</p> <p>If a tag is present, the data for that tag appears on the bottom line of the display in hexadecimal format. If there is more data than can fit on the bottom line (such as for 96-bit tags), the bottom line will cycle from the first 8 bytes (most significant) to the next 4 bytes (least significant) approximately every 2 seconds. Whatever hexadecimal data that can fit on two screens is displayed and cycled through.</p> <p>For example, if the tag contains the data 0x112233445566778899001122, when this option is selected, the bottom line of the display shows: <b>1122334455667788</b> for 2 seconds followed by <b>99001122</b> for 2 seconds. The printer cycles through these indefinitely.</p> <p>The printer rereads the tag every cycle, so if the tag changes, data is displayed for the current tag over the antenna.</p>

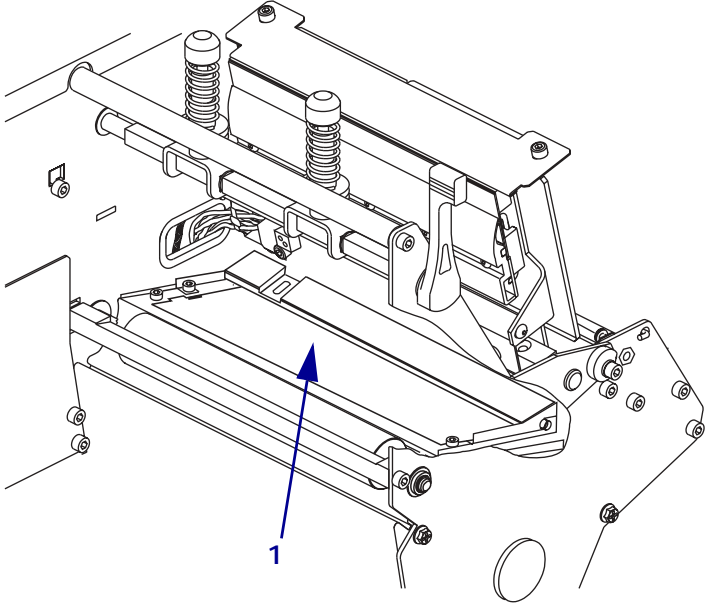

---

# RFID Guidelines

This chapter describes how Radio Frequency Identification (RFID) works and provides the commands used to create RFID labels.

## Contents

Overview .....	66
Transponder Placement .....	66
ZPL Commands for RFID Applications .....	66
Electronic Product Code (EPC) .....	67
EPC Structure in RFID Labels .....	67
Getting Started with RFID .....	68
Creating Basic RFID Label Formats .....	69
RFID Label Format 1—Write a 96-bit Tag in Hexadecimal .....	70
RFID Label Format 2—Write a 64-bit Tag in Hexadecimal .....	71
RFID Label Format 3—Write a 96-bit Tag in ASCII .....	72
RFID Label Format 4—Read Data from Tag and Print on Label .....	73
RFID Label Format 5—Write Tag, Read Tag, and Print Data on Label .....	74
RFID Label Format 6—Write Tag, Read Tag, and Return Results to Host .....	75
ZPL II Commands for RFID .....	77
^HR Calibrate RFID Transponder Position .....	78
^HV Host Verification .....	80
^RB Define EPC Data Structure .....	81
^RF Read or Write RFID Format .....	83
^RM Enable RFID Motion .....	85
^RR Specify RFID Retries for a Block .....	86
^RS RFID Setup .....	87
^RT Read RFID Tag .....	91
^RW Set RFID Read and Write Power Levels .....	93
^RZ Set RFID Tag Password .....	94
^WT Write Tag .....	95
^WV Verify RFID Write Operation .....	97

## Overview

The R110Xi/R170Xi RFID label printers/encoders serve as dynamic tools for both printing and encoding RFID labels, tickets, and tags. The printer encodes information on ultra-thin UHF RFID transponders that are embedded in “smart” labels. It then immediately verifies proper encoding and prints bar codes, graphics, and/or text on the label’s surface. For more information about RFID media, see [Table 4, Types of Media on page 14](#).

How well that an encoded RFID label functions depends on factors such as where the label is placed on an item as well as on the contents of the item (such as metals or liquids). Contact the supplier of your RFID transponders for assistance with these types of issues.

## Transponder Placement

The RFID transponder, which is sometimes called the RFID tag, is usually comprised of an antenna that is bonded to an integrated circuit (IC) chip. The IC chip contains the RF circuit, coders, decoders, and memory. If you hold an RFID label up to the light, you can see the transponder’s antenna embedded within the label, and you can feel a bump in the label where the IC chip is located.

Communication between the RFID label and the printer is established when the label’s transponder lines up with the printer’s antenna. The optimal transponder programming position varies with the transponder size, its configuration, and the type of RFID IC chip used.

Print quality may be affected by printing directly over the transponder. In particular, there is an area on each label immediately around the location of the IC chip where the printer may print with low quality. Design your printed label around the location of the chip in the type of approved RFID label that you select.



**Important** • It is important to use transponders that have been specifically approved for use in this RFID printer. Failure to do so may result in the inability to read or write to the embedded RFID tags. As new transponders become commercially available, Zebra will evaluate them for compatibility with this printer. To order labels with transponders that are approved for your specific RFID printer, contact your authorized Zebra reseller.

## ZPL Commands for RFID Applications

Each RFID label has memory that can be read and most have memory that can be written to through Zebra Programming Language (ZPL) commands. Use ZPL to read and encode (write to) RFID labels just as you would use ZPL to print data on the labels. You can use serialized fields, field variables, and any other ZPL features (such as the command `^HV` on page 80 to return the results to a host computer).

The RFID-specific ZPL commands for this printer are described in [ZPL II Commands for RFID on page 77](#). For examples of how you may use the ZPL commands, see [Creating Basic RFID Label Formats on page 69](#).

For more information about non-RFID ZPL commands and how to use them, refer to the [ZPL II Programming Guide](#) (part number 46530L). A copy is available on the R110Xi/R170Xi User CD (part number 23062-003) and online at <http://www.zebra.com/manuals>.

## Electronic Product Code (EPC)

EPC is a product numbering standard that can be used to identify a variety of items by using RFID technology. The 96-bit EPC code links to an online database, providing a secure way of sharing product-specific information along the supply chain.

As with bar codes, EPC is divided into numbers that identify the manufacturer and product type. However, EPC contains the following additional information:

- **Header**—identifies the length, type, structure, version, and generation of EPC
- **Manager Number**—identifies the company or company entity
- **Object Class**—similar to a stock keeping unit (SKU)
- **Serial Number**—the specific instance of the Object Class being tagged

Additional fields may be used as part of the EPC code to encode and decode information from different numbering systems into human-readable form.

## EPC Structure in RFID Labels

In the printer, you can subdivide transponder data into unique fields. You can customize these fields to create “smart” labels that meet your needs or that meet the standards necessary in EPC programming.

The `^RB` ZPL command is used to define EPC structure. EPC field data can be delimited with any of the following characters:

, ~ ! @ # \$ % ^ & \* | . < > / \ : ;

See [^RB on page 81](#) for more information about and examples for defining EPC structure.

## XML-Enabled Printing

This printer contains the XML-Enabled Printing option, which offers increased flexibility and interoperability by making it possible to integrate Zebra printers quickly and easily into most Enterprise Resource Planning (ERP) systems and their applications. XML-enabled printers print directly from Oracle Warehouse Management System (WMS), Mobile Supply Chain Applications (MSCA), and many other ERP vendor applications. XML-enabled label formats upload directly to the label printer, and the XML data stream is sent via TCP/IP directly to the appropriate Zebra printer.

For more information about XML-Enabled Printing, refer to the *Zebra XML-Enabled Printer Reference Guide* (part number 13426L-001). A copy is available on the R110Xi/R170Xi User CD (part number 23062-003) and online at <http://www.zebra.com/manuals>.

## Getting Started with RFID

How you set up your printer for RFID applications is determined in part by the transponder that you select. This section guides you through that selection and the settings that you may need to change on your printer to make RFID reading and encoding possible. When you have completed this section, you will be ready to program your RFID label formats.

**Select a Transponder Type** Before you purchase RFID labels, determine what type of RFID transponder to use (Table 10). Different transponder types can have different attributes. Some transponders can only be read while others can be read and written to repeatedly. Transponders also have different amounts of available memory, which corresponds to the amount of data that can be encoded in it. Select the combination that best suits your needs.

**Table 10 • Characteristics of Different Transponder Types**

Transponder Type	Read	Write	Size (in bits)
Class 0	X		96 bits
Class 0+	X	X	96 bit (ID) 104 bit (USER)
Class 1 64 bits	X	X	64 bits
Class 1 96 bits	X	X	96 bits
ISO18000	X	X	Varies

**Set Tag Type** After you have selected a transponder type and purchased labels, set the transponder (tag) type on the printer. Do this through the front panel menu (see [Specify RFID Tag Type on page 63](#)) or through the ^RS ZPL command (see [^RS on page 87](#)).

**Set Power Settings** Each transponder has specific power setting requirements, which define how much power the printer’s antenna will emit to “energize” the transponder in its program field. The tag type that you are using must match the RFID power settings of the printer. If necessary, you can change the power settings through the front panel (see [View or Change RFID Read Power](#) or [View or Change RFID Write Power on page 63](#)) or through the ^RW ZPL command (see [^RW on page 93](#)).

**Perform RFID Transponder Calibration** If you are using RFID labels that were designed to meet the specifications of this printer, you do not need to perform RFID transponder calibration. The printer will automatically place the labels in the optimal programming position.

However, if you are using RFID labels that were not designed to meet the specifications of this printer, you may need to perform an RFID transponder calibration to determine the optimal programming position for your media. If necessary, you can perform this calibration through the front panel (see [Calibrate RFID Tag on page 63](#)) or through the ^HR ZPL command (see [^HR on page 78](#)).



## Creating Basic RFID Label Formats

After you have selected a transponder type and set your printer appropriately, use the ZPL samples in this section as a base for programming your own RFID label formats. For specific information about individual ZPL commands, see [ZPL II Commands for RFID on page 77](#).

### To create an RFID label based on a sample label, complete these steps:

1. Set up the printer, and turn the power On (I).
2. Using any word processor or text editor that is capable of creating ASCII-only files (for example, use Microsoft® Word and save as a .txt file), type in the label format exactly as shown in the desired sample.
3. Save the file to your computer.  
When naming the file, use .zpl as the extension for the file (for example, you may choose to name a file format1.zpl).
4. Copy the file to the printer.  
If you are connected to the printer via the parallel port, from the DOS command window, use the “COPY” command to send a file to the printer. For example, if your file name is **format1.zpl**, type  

```
COPY FORMAT1.ZPL XXXX
```

where XXXX is the port to which your printer is connected (such as LPT1).
5. Compare your label results with those shown in the sample. If your printout does not look like the one shown, confirm that the file you created is identical to the format shown, then repeat the printing procedure.
6. Check the RFID data on your label.
  - a. Open the printhead, and place the label above the reader in the printer.
  - b. Use the front panel to view the transponder data (see [Read and Display RFID Tag Data on page 64](#)).
  - c. Compare your RFID data with that shown in the sample. If your front panel display does not look like what is shown, confirm that the file you created is identical to the format shown, then repeat the printing procedure.
7. If nothing prints, make sure that your system is set up correctly by referring to the following:
  - [Printer Setup on page 7](#)
  - [Printer Operation on page 19](#)
  - [Front Panel Controls on page 41](#)
  - [Troubleshooting on page 125](#)

## RFID Label Format 1—Write a 96-bit Tag in Hexadecimal

Line Number	Type This ZPL Code	Function of ZPL Code
1	^XA	Indicates start of label format.
2	^RS4	Sets tag type to EPC Class 1 96-bit.
3	^FO50,50 ^AON,65 ^FDsimple write example ^FS	Prints “Simple write example” on the label at location 50,50.
4	^RFW,H ^FD112233445566778899001122 ^FS	W,H = write hex Writes the 12 bytes of data (96 bits) to the tag. The data written is: 112233445566778899001122
5	^XZ	Indicates end of label format.

### Resulting Label

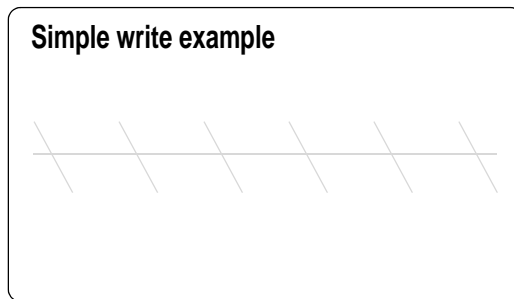

### Programmed to Transponder

112233445566778899001122

### Front Panel Display (toggles between these two)

RFID TAG DATA  
1122334455667788

RFID TAG DATA  
99001122

## RFID Label Format 2—Write a 64-bit Tag in Hexadecimal

Line Number	Type This ZPL Code	Function of ZPL Code
1	^XA	Indicates start of label format.
2	^RS3	Sets tag type to EPC Class 1 64-bit.
3	^FO50,50 ^A0N,65 ^FDsimple write example ^FS	Prints “Simple write example” on the label at location 50,50.
4	^RFW,H ^FD1122334455667788 ^FS	W,H = write hex Writes the 8 bytes of data (64 bits) to the tag. The data written is: 1122334455667788
5	^XZ	Indicates end of label format.

### Resulting Label

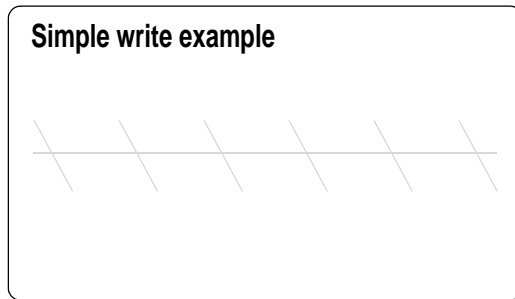

### Programmed to Transponder

1122334455667788

### Front Panel Display

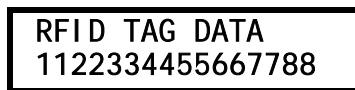

## RFID Label Format 3—Write a 96-bit Tag in ASCII

This label format is different in what shows on the front panel. The front panel always displays RFID data in hexadecimal.

Line Number	Type This ZPL Code	Function of ZPL Code
1	^XA	Indicates start of label format.
2	^RS4	Sets tag type to EPC Class 1 96-bit.
3	^FO50,50 ^AON,65 ^FDsimple write example ^FS	Prints “Simple write example” on the label at location 50,50.
4	^RFW,A ^FD00 rfid data ^FS	W,A = write ASCII Writes the 12 bytes of data (96 bits) to the tag. The data written is: 00 rfid data
5	^XZ	Indicates end of label format.

### Resulting Label

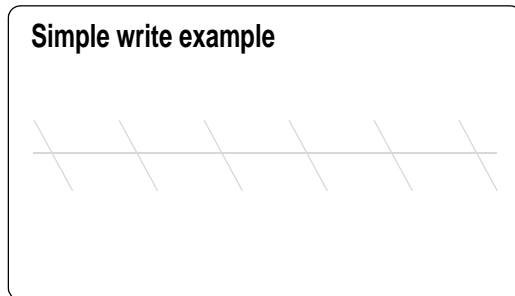

### Programmed to Transponder

00 rfid data

### Front Panel Display (toggles between these two)

RFID TAG DATA  
3030207266696420

RFID TAG DATA  
64617461

## RFID Label Format 4—Read Data from Tag and Print on Label

This example assumes that the tag created using *RFID Label Format 1—Write a 96-bit Tag in Hexadecimal* on page 70 is being read.

Line Number	Type This ZPL Code	Function of ZPL Code
1	^XA	Indicates start of label format.
2	^RS4	Sets tag type to EPC Class 1 96-bit.
3	^FO50,50 ^AON,40 ^FN0 ^FS	^FN0 is a placeholder field variable for the tag data that will be read in the following line. When the label prints, the data read from the tag will be printed at 50,50.
4	^FN0 ^RFR,H ^FS	R,H = read hexadecimal The read results are put into field variable 0 (^FN0). At this point, the printer substitutes previous instances of ^FN0 in the label format with the data from this field. The data read from the tag will be padded with zeroes to the maximum bit size.
5	^XZ	Indicates end of label format.

### Read from Transponder

112233445566778899001122

### Resulting Label

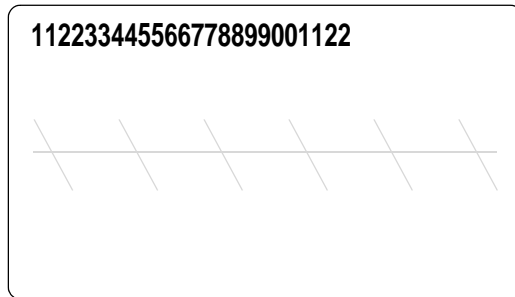

### Front Panel Display (toggles between these two)

RFID TAG DATA  
1122334455667788

RFID TAG DATA  
99001122

## RFID Label Format 5—Write Tag, Read Tag, and Print Data on Label

Line Number	Type This ZPL Code	Function of ZPL Code
1	^XA	Indicates start of label format.
2	^RS4	Sets tag type to EPC Class 1 96-bit.
3	^FO60,60 ^A0N,40 ^FN7 ^FS	When the label prints, the data read from the tag at field variable 7 (^FN7) will be printed at location 60,60.
4	^RFW,A ^FD0data ^FS	W,A = write ASCII Writes “0data” into the block padded with 8 bytes of zeroes to make the data 12 bytes. The data written is: 306461746100000000000000 (“0data” in ASCII)
5	^FN7 ^RFR,A ^FS	R,A = read ASCII Reads the tag data into field variable 7 (^FN7). After this occurs, any fields in this label format that have ^FN7 will be replaced with this read data.
6	^XZ	Indicates end of label format.

### Programmed to Transponder

306461746100000000000000

### Read from Transponder

306461746100000000000000

### Resulting Label



### Front Panel Display (toggles between these two)

RFID TAG DATA  
3064617461000000

RFID TAG DATA  
00000000

## RFID Label Format 6—Write Tag, Read Tag, and Return Results to Host

Line Number	Type This ZPL Code	Function of ZPL Code
1	^XA	Indicates start of label format.
2	^RS3	Sets tag type to EPC Class 1 64-bit.
3	^FO50, 50 ^A0N, 65 ^FN3 ^FS	When the label prints, the data read from the tag at field variable 3 (^FN3) will be printed at location 50,50.
4	^RFW, H ^FD0102030405 ^FS	W,H = write hex Writes 8 bytes of data (64 bits) to the tag with 3 bytes of zeroes as padding. The data written is: 0102030405000000
5	^FN3 ^RFR, H ^FS	R,H = read hexadecimal Reads the tag data into field variable 3 (^FN3). After this occurs, any fields in this label format that have ^FN3 will be replaced with this read data.
6	^HV3	Return the value in ^FN3 to the host computer. Data is sent over whichever communication channel is established with the host (such as parallel, serial, USB, ethernet) In this example, 0102030405000000 would be returned to the host.
7	^XZ	Indicates end of label format.

### Programmed to Transponder

0102030405000000

### Read from Transponder

0102030405000000

### Resulting Label

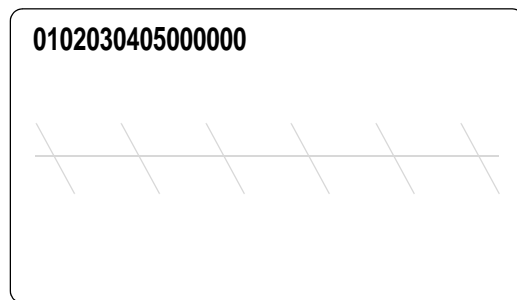

**Front Panel Display**

RFID TAG DATA  
0102030405000000

**Sent to Host Computer**

0102030405000000



## ZPL II Commands for RFID

This section contains the ZPL commands for RFID-specific applications. For non-RFID ZPL commands, refer to the *ZPL II Programming Guide* (part number 46530L). A copy is available on the R110Xi/R170Xi User CD (part number 23062-003) and online at <http://www.zebra.com/manuals>.

In addition to reading or encoding RFID tags, these ZPL commands also provide for RFID exception handling, such as setting the number of read/write retries before declaring a transponder defective (set with ^RT and ^WT) or setting the number of labels that will be attempted if an error occurs (set with ^RS).

For example, if an RFID label fails to program correctly or if the transponder cannot be detected, the printer ejects the label and prints VOID across it. The printer will try to print another label with the same data and format for the number of RFID labels specified by the ^RS command. If the problem persists, the printer follows the error handling instructions specified by the ^RS command: the printer may remove the problematic format from the print queue and proceed with the next format (if one exists in the buffer), or it may place the printer in Pause or Error mode.



**Important** • If a parameter in the following tables is designated as *not applicable*, any value entered for the parameter will be ignored, but the place holder for the field is required.



## Calibrate RFID Transponder Position

**Description** This command initiates an RFID transponder calibration for a specific RFID label and returns the results to the host computer. This calibration is used to determine the optimal programming position for RFID media that may not meet the transponder placement specifications for the printer.



**Note** • You do not need to perform transponder calibration for RFID media that meets the transponder placement specifications for the printer. To order media that is designed for use with your RFID printer, contact your authorized Zebra reseller.

During transponder calibration, the printer feeds the RFID label one-dot row at a time while taking readings (via the READ TAG command and the WRITE TAG commands) to profile the RFID transponder. Based on the results, the printer determines the optimal programming position for the label and returns a results table to the host. The calibrated value is used as the programming position for the ^RS command, can be overwritten by the ^RS command, and is saved to nonvolatile memory (the value is saved even if the power is turned off).

This calibration takes into account the print mode, backfeed mode, and tear off position. The \*\*\* option in the \*♦♣ \*◇♠ ♣♠\*† front panel parameter performs the same calibration but does not create a results table.



If a label format specifies a value for parameter p (read/write position of the transponder) in the ^RS command, that value will be used for the programming position for all RFID labels until a new position is specified or until the printer is turned Off (O) and then back On (I).

**Format** ^HRa , b

The following table identifies the parameters for this format.

Parameters	Details
a = start string	User text to appear before the results table. <i>Accepted values:</i> any string less than 65 characters <i>Default value:</i> start
b = end string	User text to appear after the results table. <i>Accepted values:</i> any string less than 65 characters <i>Default value:</i> end

### Comments

- Based on the recommended transponder placement position for most RFID labels, the printer's default RFID programming position is the label length minus 1 mm (1/16 in.). To return to the default programming position at any time, use the RESTORE option in the \*♦♣ \*◇♠ ♣♠\*† front panel parameter (see [Calibrate RFID Tag on page 63](#)).

- At the end of calibration, a results table is returned to the host. Each line in the results table appears as:

Row, Read Result, Write Result

where

Row = the dot row where calibration occurred

Read Result = results of calibration (R = read, “ ” = unable to read)

Write Result = results of calibration (W = write, “ ” = unable to write)



**Example** • If the following command is sent to the printer:

```
^XA^HR^XZ
```

The printer starts the transponder calibration and returns a results table such as the following:

```
start
position=195
215, ,
214, ,
213, ,
212, ,
211, ,
210, ,W
209,R,
208, ,
207, ,
206, ,W
205,R,
204, ,
203, ,
202, ,W
201,R,W
200,R,W
199,R,W
198,R,W
197,R,W
196,R,W
195,R,W <----*****
194,R,W
193,R,W
192,R,W
191,R,W
190,R,W
189,R,
188, ,
187, ,
186, ,
185, ,
.
.
.
end
```

In this example, the optimal programming position is 195. This is identified at the top of the table (position=195) and with an the arrow (<----\*\*\*\*\*) in the table.

**^HV****Host Verification**

**Description** This command is used to return data from specified fields, along with an optional ASCII header, to the host computer. The command can be used with any field that has been assigned a number with the ^RT command or the ^FN and ^RF commands.

**Format** ^HV# , n , h

The following table identifies the parameters for this format.

Parameters	Details
# = field number specified with another command	The value assigned to this parameter should be the same as the one used in another command. <i>Accepted values:</i> 0 to 9999 <i>Default value:</i> 0
n = number of bytes to be returned	<i>Accepted values:</i> 1 to 256 <i>Default value:</i> 64
h = header	Header (in uppercase ASCII characters) to be returned with the data. <i>Acceptable values:</i> 0 to 3072 characters <i>Default value:</i> no header

## ^RB

### Define EPC Data Structure

**Description** This command defines the structure of EPC data, which can be read from or written to an RFID transponder.

RFID transponders can have different partitions defined. This command specifies the number of partitions and how many bits are in each partition.



**Important** • All parameters in this command are persistent and will be used in subsequent formats if not provided. The values are initially set to the default values.

**Format** ^RBn,p0,p1,p2, . . . , p15

The following table identifies the parameters for this format.

Parameters	Details
n = total bit size of the field	<i>Accepted values:</i> 1 to n, where n is the bit size of the tag. <i>Default value:</i> 96
p1 . . . p15 = partition sizes	Specify each partition size. These must add up to the total bit size. <i>Accepted values:</i> 1 to 64 bit total bit size <i>Default value:</i> 1



**Example 1** • The following command specifies that there are 96 bits used with three fields. Fields 1, 2, and 3 contain 10, 26, and 60 bits, respectively.

```
^RB96,10,26,60
```

The ZPL code to write to a tag with this format would look like this:

```
^RFW,E^FD1000.67108000.1122921504606846976^FS
```

When writing to the tag, the data will be stored in the tag in the following way:

- Field 1 contains 1000. This value is stored in the first 10 bits
- Field 2 contains 67108000. This value is stored in the next 26 bits.
- Field 3 contains 1122921504606846976. This value is stored in the remaining 60 bits.



**Example 2** • The following command specifies that there are 64 bits used with eight 8-bit fields.

```
^RB64,8,8,8,8,8,8,8,8^FS
```

The ZPL code to write to a tag with this format would look like this:

```
^RFW,E^FD1.123.160.200.249.6.1.0^FS
```

When writing to the tag, each set of data is written in its respective 8-bit field.



**Example 3** • This example uses the SCTIN-64 standard, which defines 64-bit structure in the following way:

	Header	Filter Value	Company Prefix Index	Item Reference	Serial Number
SGTIN-64	2	3	14	20	25
	10 (binary value)	8 (decimal capacity)	16,383 (decimal capacity)	9 to 1,048,575 (decimal capacity*)	33,554,431 (decimal capacity)

\* Capacity of Item Reference field varies with the length of the company prefix.

The ZPL code to write to a tag with this format would look like this:

```

^XA
^RB64,2,3,14,20,25
^RFW,E^FD0,3,12345,544332,22335221^FS
^XZ
    
```

These commands would put

- 0 in the header
- 3 as the filter value
- 12345 as the company prefix
- 544332 as the item reference
- 22335221 as the serial number

To read this EPC data and print the results on the label, you would use the following code:

```

^XA
^RB64,2,3,14,20,25
^FO50,50^A0N,40^FN0^FS
^FN0^RFR,E^FS
^XZ
    
```

The resulting label would look like this:

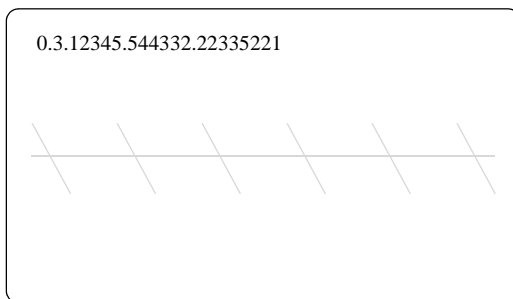

# ^RF

## Read or Write RFID Format

**Description** This command allows you to read or write to an RFID tag.



**Note** • To read into a field variable, you must have a ^FN command in the

**Format** ^RF $\circ$ ,  $t$ ,  $b$ ,  $n$

The following table identifies the parameters for this format.

Parameters	Details
$\circ$ = operation	The action to be performed. <i>Accepted values:</i> <ul style="list-style-type: none"> <li>• W = write to the tag</li> <li>• L = write with LOCK (if supported by tag type)</li> <li>• R = read the tag</li> </ul> <i>Default value:</i> W
$t$ = type	<i>Accepted values:</i> <ul style="list-style-type: none"> <li>• A = ASCII</li> <li>• H = Hexadecimal</li> <li>• E = EPC (ensure proper setup with the ^RB command)</li> </ul> <i>Default value:</i> H
$b$ = starting block number	<i>Accepted values:</i> 0 to $n$ , where $n$ is the maximum number of blocks for the tag. <i>Default value:</i> 0
$n$ = number of blocks to read*	This parameter is valid only for the read operation. <i>Accepted values:</i> 1 to $n$ , where $n$ is the maximum number of blocks for the tag type minus the starting block number. For example, if the tag has 8 blocks (starting with block 0) and you start with block 6, $n$ can be 2. This would return block 6 and block 7 information. <i>Default value:</i> 1

\*Not applicable for R110Xi/R170Xi

**Examples •****Write ASCII**

This example writes 96-bit data.

```
^XA
^RS4
^RFw,a^FD00 my data^FS
^XZ
```

**Write Hex**

This example writes 64-bit data.

```
^XA
^RS3
^RFw,H^FD1122334455667788^FS
^XZ
```

**Write EPC**

This example writes 96-bit data, as specified by the ^RB command.

```
^XA
^RB96,8,3,3,20,24,38
^RFw,e^FD16,3,5,78742,146165,1234567891^FS
^XZ
```



## ^RM

### Enable RFID Motion

**Description** This command enables or disables RFID motion. By default, labels automatically print at the end of the format. This command allows you to inhibit the label from actually moving when it reaches the program position, which is useful for debugging, setup, and custom applications. This parameter is not persistent (carried over from label to label).

**Format** ^RM`e`

The following table identifies the parameters for this format.

Parameters	Details
<code>e</code> = enable	<i>Accepted values:</i> Y (Yes, move the label), N (No, do not move the label) <i>Default value:</i> Y

## ^RR

### Specify RFID Retries for a Block

**Description** This command changes the number of times that the printer attempts to read or write to a particular block of a single RFID tag. By default, the printer will attempt six retries. This command is persistent and will be used in subsequent formats if not provided.



**Important** • This command is not the same as the number of labels to try parameter in the ^RS command.

**Format** ^RRn

The following table identifies the parameters for this format.

Parameters	Details
n = number of retries	Accepted values: 0 to 10 Default value: 0



#### Examples •

##### Set read block retries to 5

```
^XA
^FN1^RR5^RFR,H^FS
^HV1^FS
^XZ
```

##### Set write block retries to 2

```
^XA
^RR2^RFW,H^FD1234^FS
^XZ
```

# ^RS

## RFID Setup

**Description** This command sets up parameters including tag type, read/write position of the transponder, and error handling.



**Important** • Use care when using this command in combination with ^RT or ^RFR for reading tag data. Problems can occur if the data read from the tag is going to be printed on the label. Any data read from the transponder must be positioned to be printed above the read/write position. Failure to do this will prevent read data from being printed on the label.

**Format** ^RS*t,p,v,n,e,a,c,s*

The following table identifies the parameters for this format.

Parameters	Details
t = tag type	<p><i>Accepted values:</i></p> <ul style="list-style-type: none"> <li>• 0 = None</li> <li>• 1 = EPC Class 0</li> <li>• 2 = EPC Class 0 Plus</li> <li>• 3 = EPC Class 1 64-bit</li> <li>• 4 = EPC Class 1 96-bit</li> <li>• 5 = ISO 18000-06B</li> </ul> <p><i>Default value:</i> 4</p>
p = read/write position of the transponder	<p>Sets the read/write position of the transponder in the vertical (Y axis) in dot rows from the top of the label. Set to 0 (no movement) if the transponder is already in the effective area without moving the media.</p> <p> <b>Important</b> • If a label format specifies a value for this parameter, this value will be used for the programming position for all labels until a new position is specified or until the printer is powered Off (O) and then back On (I).</p> <p><i>Accepted values:</i> 0 to label length <i>Default value:</i> label length minus 1 mm (1/16 in.)</p>
v = length of void printout	<p>Sets the length of the void printout in vertical (Y axis) dot rows.</p> <p><i>Accepted values:</i> 0 to label length <i>Default value:</i> label length</p>
n = number of labels	<p>The number of labels that will be attempted in case of read/encode failure.</p> <p><i>Accepted values:</i> 1 to 10 <i>Default value:</i> 3</p>

Parameters	Details
e = error handling	<p>If an error persists after the specified number of labels are tried, perform this error handling action.</p> <p><i>Accepted values:</i></p> <ul style="list-style-type: none"> <li>• N = No action (printer drops the label format causing the error and moves to the next queued label)</li> <li>• P = Place printer in Pause mode (label format stays in the queue until the user cancels)</li> <li>• E = Place printer in Error mode (label format stays in the queue until the user cancels)</li> </ul> <p><i>Default value:</i> N</p> <p> <b>Note</b> • You can set the printer to send an error message to the host as an unsolicited message for each failure. To enable or disable the unsolicited error message, refer to the ^SX and ^SQ ZPL commands. The parameter for the RFID error in these commands is V.</p>
a = signals on applicator	<p>When the value for parameter p (read/write position of the transponder) is nonzero, this parameter changes the number of start and stop print signals required for printing.</p> <p>In Single mode, one start print command is required. In Double mode, two are required, so the printer will resume printing only after the second start print command is received.</p> <p><i>Accepted values:</i></p> <ul style="list-style-type: none"> <li>• S (single) signal</li> <li>• D (double) signal</li> </ul> <p><i>Default value:</i> S</p>
c = certify tag with a pre-read*	* Not used in this version of the printer. The encoder does this automatically.
s = void print speed	<p>If a label is voided, the speed at which “VOID” will be printed across the label.</p> <p><i>Accepted values:</i> any valid print speed</p> <p><i>Default value:</i> the printer’s maximum print speed</p>



**Example 1** • This example sets the printer to move the media to 800 dots from the top of the media [or label length minus 800 from the bottom (leading edge) of the media] and voids the rest of the media in case of an error. The printer will try to print two labels and then will pause if printing and encoding fail.

```

^XA
^RS,800,,2,P^FS
^XZ
    
```

The following illustration shows the resulting voided label. Note where the void starts. The media has been moved 800 dot rows from the top of the label (label length minus 800 dot rows from the bottom (leading edge) of a label) to bring the transponder into the effective area to read/write a tag. If the printer fails the operation, the rest of the media is voided.

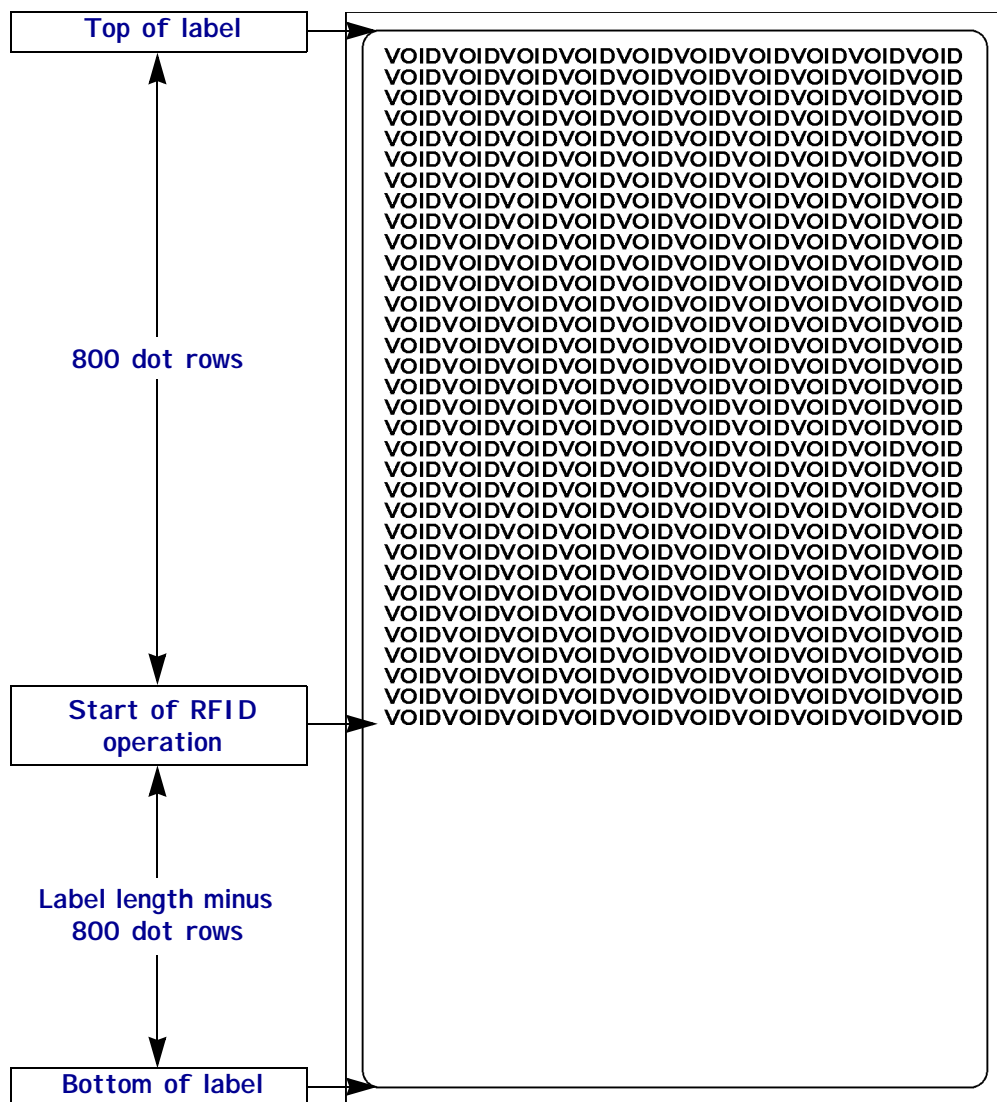



**Example 2** • This example sets the printer to move the media to 800 dots from the top of the media [or label length - 500 from the bottom (leading edge) of the media] and prints “VOID” 500 dots in vertical length (Y axis) in case of an error.

```

^XA
^RS,800,500,2,P^FS
^XZ
    
```

The following illustration shows the resulting voided label. Note where the void starts. The media has been moved 800 dot rows from the top of the label [label length minus 800 dot rows from the bottom (leading edge) of a label] to bring the transponder into the effective area to read/write a tag. If the printer fails the operation, an area that is 500 dot rows of the media is voided instead of the entire rest of the media.

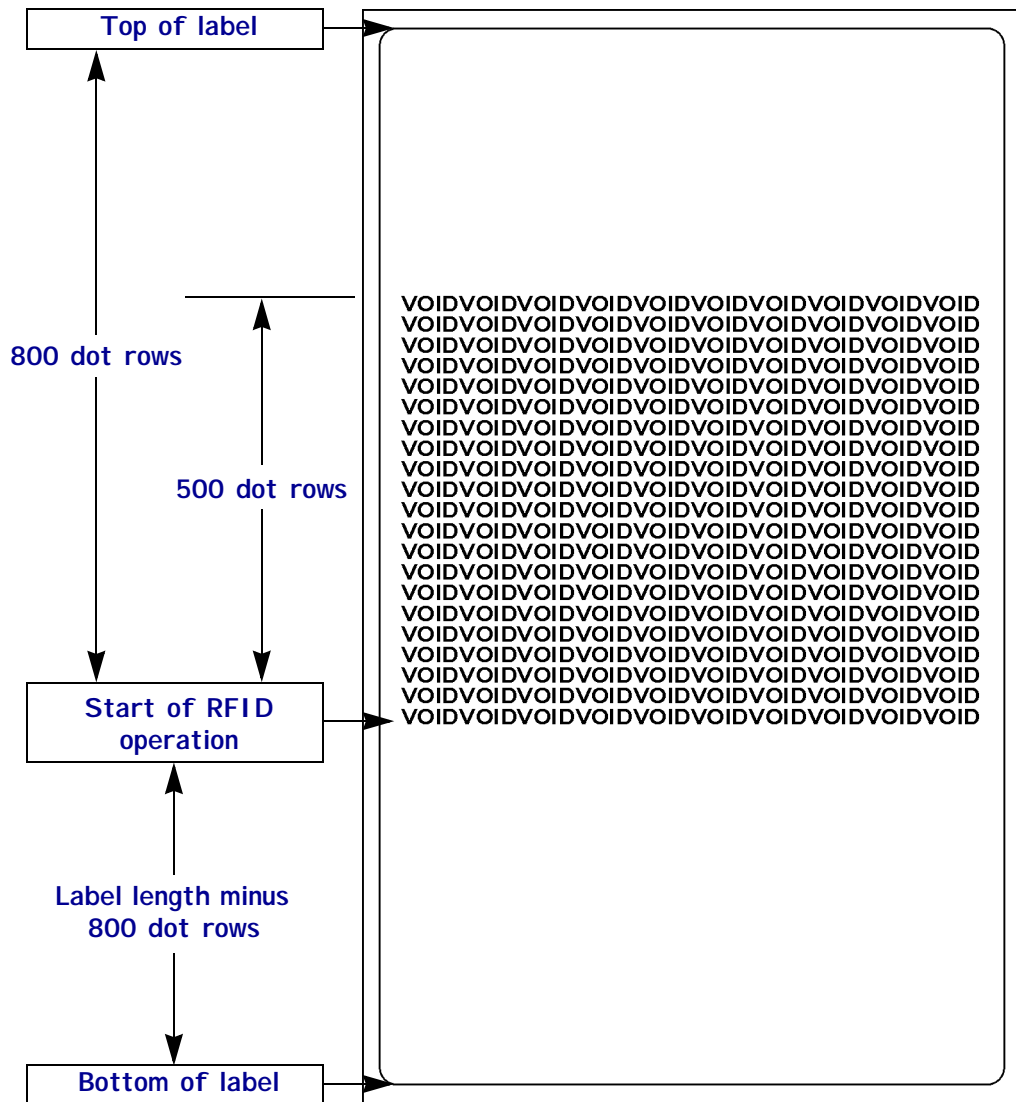

# ^RT

## Read RFID Tag

**Description** This command tells the printer to read the current RFID tag data. The data can be sent back to the host via the ^HV command.



**Note** • It is recommended that you use the ^RF, ^RM, and ^RR commands rather than the ^RT command. The ^RT command is provided only for backward-compatibility with label formats that were developed for other Zebra RFID printers.

**Format** ^RT#,b,n,f,r,m,s

The following table identifies the parameters for this format.

Parameters	Details
# = number to be assigned to the field	<i>Accepted values:</i> 0 to 9999 <i>Default value:</i> 0
b = starting block number	<i>Accepted values:</i> 0 to <i>n</i> , where <i>n</i> is the maximum number of blocks for the tag. <i>Default value:</i> 0
n = number of blocks to read*	<i>Accepted values:</i> 1 to <i>n</i> , where <i>n</i> is the maximum number of blocks for the tag type minus the starting block number. For example, if the tag has 8 blocks (starting with block 0) and you start with block 6, <i>n</i> can be 2. This would return block 6 and block 7 information. <i>Default value:</i> 1
f = format	<i>Accepted values:</i> <ul style="list-style-type: none"> <li>• 0 (ASCII)</li> <li>• 1 (Hexadecimal)</li> </ul> <i>Default value:</i> 0
r = number of retries	Changes the number of times that the printer attempts to read a particular block of a single RFID tag. (Same retry rules as the ^RR command.) <i>Accepted values:</i> 0 to 10 <i>Default value:</i> 0
m = motion	Enables or disables RFID motion for the current field. <i>Accepted values:</i> <ul style="list-style-type: none"> <li>• 0 (Feed label after writing.)</li> <li>• 1 (No feed after writing. Other ZPL may cause a feed.)</li> </ul> <i>Default value:</i> 0
s = special mode*	For EPC Class 1 (Alien reader) only. Not applicable for EPC class 0. <i>Default value:</i> 0 <i>Accepted values:</i> <ul style="list-style-type: none"> <li>• 0 (Do not read if mismatched checksum.)</li> <li>• 1 (Read even if mismatched checksum.)</li> </ul>

\*Not applicable for R110Xi/R170Xi



**Example** • This sample reads a tag, prints the data on a label, and sends the string Tag Data:xxxxxxxx back to the host. The data read will go into the ^FN1 location of the format. The printer will retry the command five times, if necessary.

```
^XA
^FO20,120^A0N,60^FN1^FS
^RT1,,,5^FS
^HV1,,Tag Data:^FS
^XZ
```



## ^RW

### Set RFID Read and Write Power Levels

**Description** This command sets the read and write power levels. This function is useful when using different tag types or transponders that require different power levels to obtain the best read and write abilities.

**Format** ^RW $r$ ,  $w$

This table identifies the parameters for this format:

Parameters	Details
$r$ = read power	Sets the power level to match the desired output as calibrated in the factory. <i>Accepted Values:</i> H (high), M (medium), or L (low) <i>Default Value:</i> H
$w$ = write power	Sets the power level to match the desired output as calibrated in the factory. <i>Accepted Values:</i> H (high), M (medium), or L (low) <i>Default Value:</i> H

## ^RZ

### Set RFID Tag Password

**Description** This command lets you define the password for the tag during writing.



**Important** • Only certain tags support this feature, so check to ensure that this command can be used with your particular tag type.

**Format** ^RZp

The following table identifies the parameters for this format.

Parameters	Details
p = password	<i>Accepted values:</i> 00 to FF (hexadecimal) <i>Default value:</i> 00

# ^WT

## Write Tag

**Description** This command allows you to program the current RFID tag.



**Note** • It is recommended that you use the ^RF, ^RM, ^RR, and ^WV commands rather than the ^WT command. The ^WT command is provided only for backward-compatibility with label formats that were developed for other Zebra RFID printers.



**Important** • Check the amount of data memory available for the tag that you will be using. If more is sent than the memory can hold, the printer truncates the data.

**Format** ^WT**b**,**r**,**m**,**w**,**f**,**v**

The following table identifies the parameters for this format.

Parameters	Details
b = block number	This parameter is tag-dependent. For most tags, use block 0. For EPC Class 0 Plus, block 0 is EPC data, and block 1 is user data. <i>Accepted values:</i> 0 to <i>n</i> , where <i>n</i> is the maximum number of blocks for the tag. <i>Default value:</i> 0
r = number of retries	Changes the number of times that the printer attempts to write to a particular block of a single RFID tag. (Same function as the ^RR command.) <i>Accepted values:</i> 0 to 10 <i>Default value:</i> 0
m = motion	Enables or disables RFID motion. (Same function as the ^RM command.) <i>Accepted values:</i> <ul style="list-style-type: none"> <li>• 0 (Feed label after writing.)</li> <li>• 1 (No Feed after writing. Other ZPL may cause a feed.)</li> </ul> <i>Default value:</i> 0
w = write protect	<i>Accepted values:</i> <ul style="list-style-type: none"> <li>• 0 (Not write protected.)</li> <li>• 1 (Write protect.)</li> </ul> <i>Default value:</i> 0

Parameters	Details
f = data format	<p><i>Accepted values:</i></p> <ul style="list-style-type: none"> <li>• 0 (ASCII)</li> <li>• 1 (Hexadecimal)</li> </ul> <p><i>Default value:</i> 0</p>
v = verify valid data	<p>Used only for Alien Class 1 tags, which have preprogrammed data in them. This parameter flags whether the preprogrammed data is verified. (Same function as the ^WV command)</p> <p><i>Default value:</i> N</p> <p><i>Accepted values:</i></p> <ul style="list-style-type: none"> <li>• N (Do not verify)</li> <li>• Y (Verify valid data [Hex A5A5 in the first two bytes] before writing)</li> </ul>



**Example** • This sample encodes data “RFIDRFID” and will try writing up to five times, if necessary.

```
^XA
^WT,5^FDRFIDRFID^FS
^XZ
```



## Verify RFID Write Operation

**Description** If write verify is enabled, this command verifies the RFID write operation to ensure that the tag about to be programmed contains the hex data “A5A5” in the first two bytes. This parameter is not persistent (carried over from label to label).



**Important** • This command is valid with Class 1 Alien tags only.

**Format** ^WVe

The following table identifies the parameters for this format.

Parameters	Details
e = enable	<i>Accepted values:</i> Y or N <i>Default value:</i> N





---

# Data Ports

This chapter describes the standard communication ports available to connect the printer to your computer or network.

## Contents

Parallel Port .....	100
Serial Port .....	102
Serial Pin Configuration .....	103
RS-232 Interface Connections .....	104
RS-422/RS-485 Interconnections .....	106
USB 2.0 Port .....	107

## Parallel Port

When communicating via the parallel port, the values selected must be the same as those used by the host equipment connected to the printer. Port selection for status information is determined by the channel sending the request. The parallel port can be set for bidirectional or unidirectional communication. The default setting is bidirectional.

A standard 36-pin parallel connector (Figure 34) is available on the back of the printer for connection to the data source.

**Figure 34 • Parallel Connector**

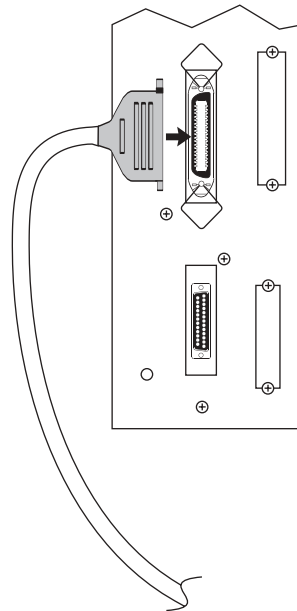

Table 11 shows the pin configuration and function of a standard computer-to-printer parallel cable.

**Table 11 • Parallel Cable Pin Configuration**

36-Pin Connectors	Description
1	nStrobe/HostClk
2–9	Data Bits 1–8
10	nACK/PtrClk
11	Busy/PtrBusy
12	PError/ACKDataReq
13	Select/Xflag
14	nAutoFd/HostBusy
15	Not used
16, 17	Ground



Table 11 • Parallel Cable Pin Configuration (Continued)

36-Pin Connectors	Description
18	+5 V at 750 mA The maximum current draw may be limited by option configuration.
19–30	Ground
31	ninit
32	nFault/NDataAvail
33, 34	Not used
35	+5 V through a 1.8 K $\Omega$ Resistor
36	NSelectin/1284 active

## Serial Port

To communicate using the serial data port of the printer, you must choose the number of data and stop bits, parity, and handshaking. Parity applies only to data transmitted by the printer because the parity of received data is ignored.

The values selected must be the same as those used by the host equipment connected to the printer. Default settings are 9600 baud, 8 data bits, 1 stop bit, no parity, and XON/XOFF.

Connect the serial data cable to the female DB-9 connector (Figure 35) on the back panel of the printer.

Figure 35 • Serial Connector

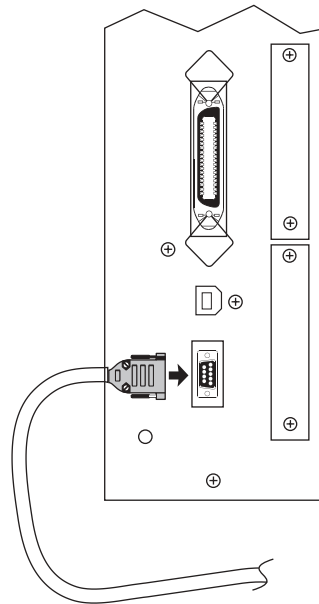

Use a DB-9 to DB-25 interface module for all RS-232 connections through a DB-25 cable. An interface module is required for RS-422/RS-485 interface support (see [RS-422/RS-485 Interconnections](#) on page 106).



**Note** • For all RS-232 input and output signals, the printer follows the specifications of the Electronics Industries Association (EIA) RS-232 and the Consultative Committee for International Telegraph and Telephone (CCITT) V.24.

## Serial Pin Configuration

Table 12 shows the pin configuration and function of the rear panel serial data connector on the printer.

**Table 12 • Serial Connector Pin Configuration**

Pin No.	Name	Description
1	—	Not connected
2	RXD	Receive data—data input to printer
3	TXD	Transmit data—data output from printer
4	DTR	Data terminal ready—output from printer
5	SG	Signal ground
6	DSR	Data set ready—input to printer
7	RTS	Request to send—output from printer
8	CTS	Clear to send—input to printer
9	+5 VDC	+5 VDC at 750 mA The maximum current draw may be limited by option configuration.

## RS-232 Interface Connections



**Note** • Adapters are available from Zebra Technologies LLC.

- RS-422/RS-485 adapter, Zebra part number 33114M
- RS-232 DB-9 to DB-25 adapter, Zebra part number 33109M

### Direct Connection to a Computer

The printer is configured as Data Terminal Equipment (DTE).



**Note** • Use a **null modem** (crossover) cable to connect the printer to a computer or any other DTE device.

Figure 36 shows the internal connections of the printer's RS-232 connector.

**Figure 36 • RS-232 Connections**

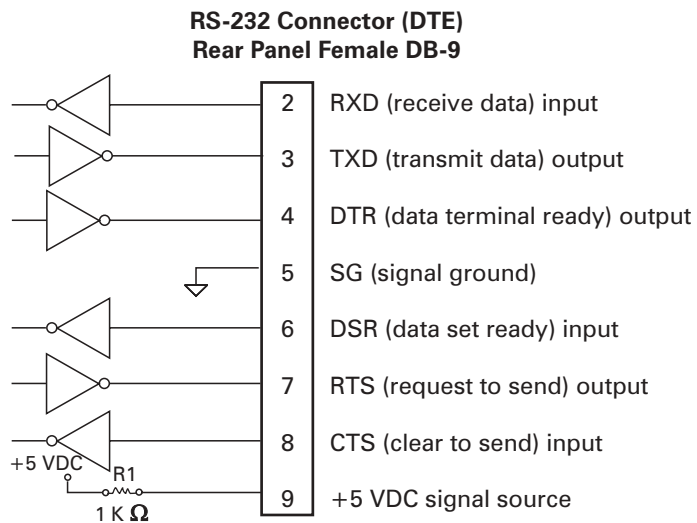

**NOTE:** Pin 1 is unused and unterminated.

Pin 9 is also available as a +5 VDC signal source at 750 mA. The maximum current draw may be limited by option configuration.



**Caution** • To enable this capability, a qualified service technician must install a jumper on the printer's main logic board on JP1, pins 2 and 3.

### DB-9 to DB-25 Connections

An interface adapter is required (Zebra part number 33109M) to connect the printer's DB-9 interface to a DB-25 connector. A generic DB-25 adapter CAN be used, although the +5 VDC signal source would not be passed through the adapter.

Figure 37 shows the connections required for the DB-9 to DB-25 interface.

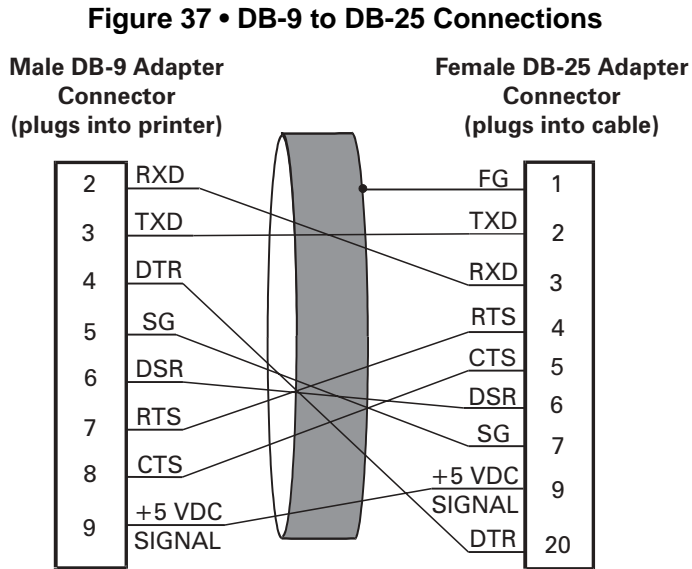

**NOTE:** Pin 1 of DB-9 connector is unused and unterminated.

### Modem Connection

When the printer is connected via its RS-232 interface to Data Communication Equipment (DCE) such as a modem, use a standard RS-232 (straight-through) interface cable.

Figure 38 shows the connections required for this cable.

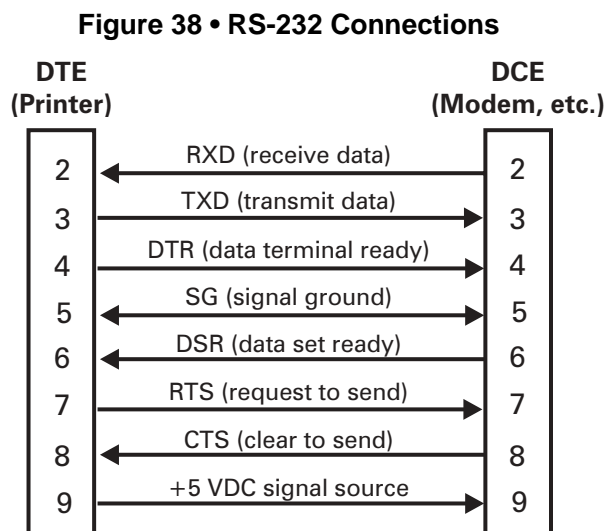

**NOTE:** Pin 1 is unused and unterminated at the printer.

## RS-422/RS-485 Interconnections

---

**Caution** • A qualified service technician must install a jumper on the printer's main logic board at JP1, pins 2 and 3, for the RS-422/RS-485 interface adapter to function properly.

---

An interface adapter (Zebra part number 33114M) is required to connect the printer's RS-232 DB-9 interface to a host computer through an RS-422 or RS-485 interface. A generic DB-25 adapter can be used. [Figure 39](#) shows the cable wiring for interconnecting the DB-9 to the interface adapter's DB-25 female connector.

**Figure 39 • DB-9 to DB-25 Connections**

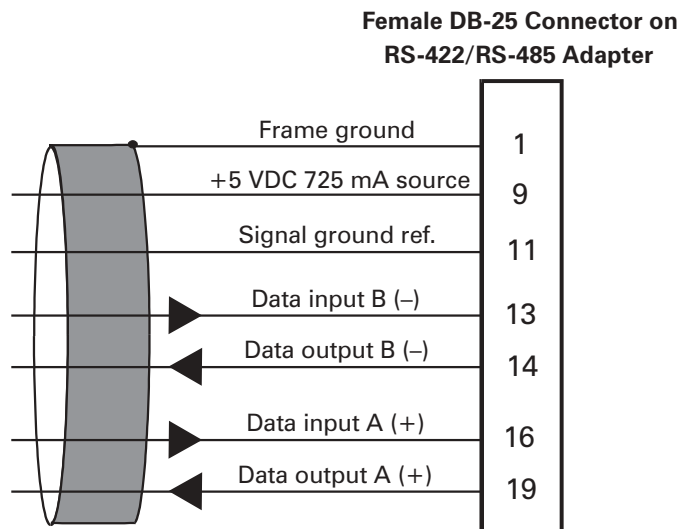

**NOTE:** Pins 2–8, 10, 12, 15, 17, 18, and 20–25 are unused and unterminated.

## USB 2.0 Port

A USB 2.0 port (which is USB 1.1 and 1.0 compatible) is available to connect your printer to the host equipment. The industry-standard USB cable has an A-male connector on one end and a B-male connector on the other end as shown in [Figure 40](#).

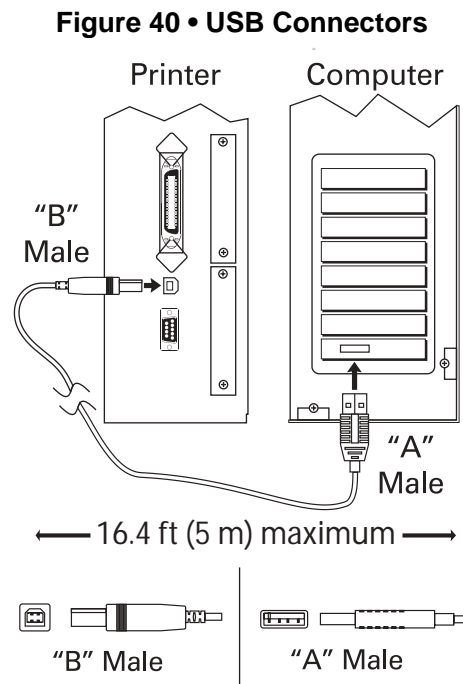

**Note** • Use a USB 2.0-certified compliant cable no longer than 16.4 ft (5 m) long. A cable that meets these requirements is available from Zebra (part number 33011).







---

# Memory Cards

This chapter describes the optional cards that can be used with the printer and gives instructions for installation.

## Contents

PCMCIA Memory Card .....	110
CompactFlash Card .....	112

## PCMCIA Memory Card

A Type I- or Type II-compliant PCMCIA memory card holds extra memory or font options for the printer. The card is hot-swappable (it can be installed while the printer is on).



**Electrostatic Discharge Caution** • Observe proper electrostatic safety precautions when handling any static-sensitive components such as circuit boards and printheads.

### To install the PCMCIA card, complete these steps:

1. Remove the PCMCIA card shield from the rear of the printer (Figure 41).

Figure 41 • PCMCIA Card Installation

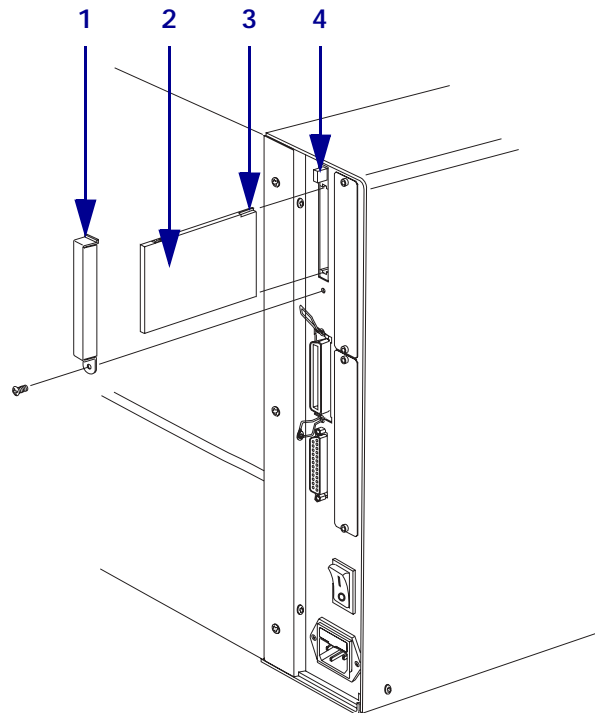

1	PCMCIA card shield
2	PCMCIA card
3	Notch
4	Card-eject button

2. Insert the PCMCIA card, with the notch **up**, into the card slot as shown. Insert it far enough to make the eject button pop out.

3. Reinstall the PCMCIA card shield over the PCMCIA card and card slot.



**Note** • The PCMCIA card may take a few minutes to initialize. The PAUSE light flashes while the card initializes. If the card is already initialized, the PAUSE light flashes only once or twice after the card is installed.

The printer is ready to operate with the additional memory or font option. To be sure that the card has successfully initialized, print a configuration label as instructed in [Print a Printer Configuration Label on page 32](#) and review it to see whether the new memory card information is listed.

## CompactFlash Card

A CompactFlash card is a nonvolatile memory card that stores data even when the power to the printer is turned off. A Type I-compliant CompactFlash card holds extra memory or optional fonts for your printer.



**Caution** • This procedure should only be performed by qualified service technicians.



**Electrostatic Discharge Caution** • Observe proper electrostatic safety precautions when handling any static-sensitive components such as circuit boards and printheads.

### To install a CompactFlash card, complete these steps:

1. Turn the AC power Off (O).
2. Disconnect the AC power cord from the printer.
3. Remove the two screws near the bottom of the electronics cover (Figure 42).

Figure 42 • Printer Exterior

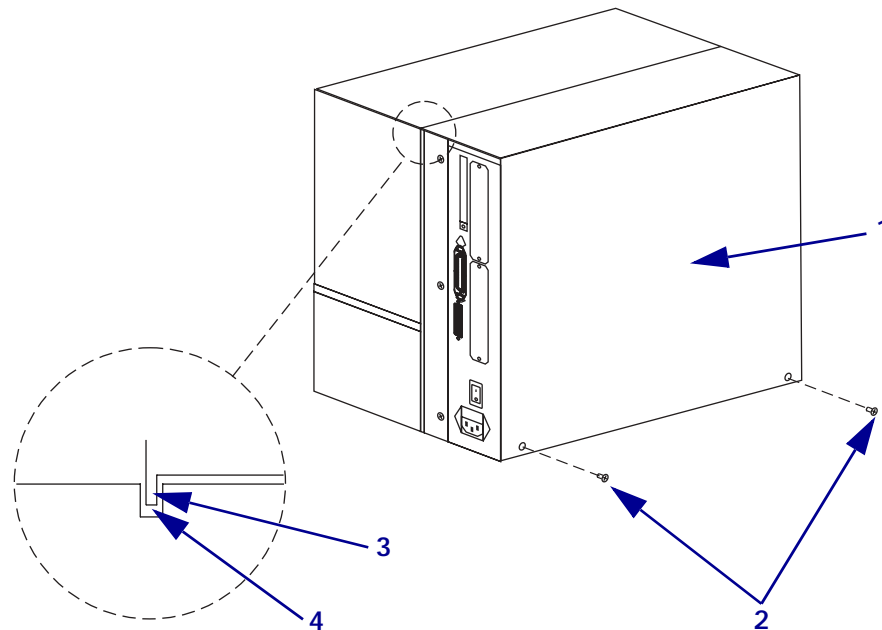

1	Electronics cover
2	Screws
3	Channel
4	Lip of cover

4. Lift the electronics cover at the rear top corner. Pull the corner forward and up, then lift the cover up and away from the printer.

5. Insert the CompactFlash card into the card slot on the upper portion of the option board. Insert the card with the back (unlabeled) side of the card facing out. The card can be inserted only one way and should snap into place.

Figure 43 shows where to insert the CompactFlash card.

**Figure 43 • Compact Flash Card Insertion**

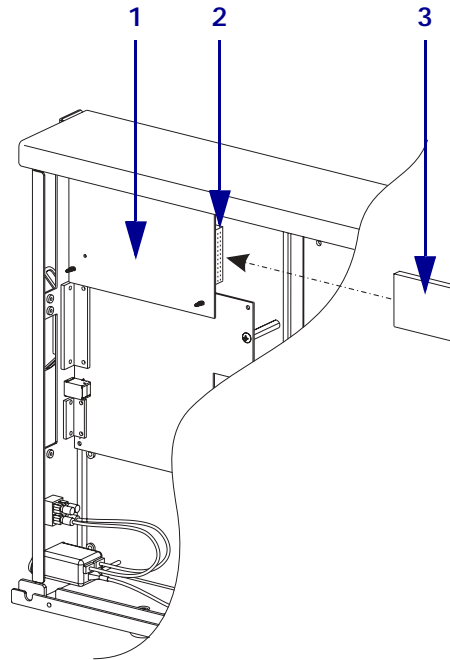

1	Option board
2	Card slot
3	Compact flash card

6. Reinstall the electronics cover by lowering the cover so the lip of the cover goes into the channel on the top of the printer.
7. Secure the cover by reinstalling the two screws near the bottom of the cover.
8. Reconnect the printer AC power cord.
9. Press and hold **CANCEL** while turning the printer On (I).  
The printer prints a configuration label.
10. Check for the presence of additional memory or optional fonts by looking at the information on the configuration label.



**Note •** The CompactFlash card may take a few minutes to initialize. If the process is not successfully completed within 10 minutes, contact Technical Support at [http://www.zebra.com/SS/service\\_support.htm](http://www.zebra.com/SS/service_support.htm) for assistance.





---

# Routine Maintenance

Cleaning your printer regularly maintains print quality and may extend the life of the printer. This section provides routine cleaning and maintenance procedures.

## Contents

Cleaning Schedule .....	116
Clean Exterior .....	116
Clean Interior .....	117
Printhead and Platen Roller .....	117
Sensors .....	119
Snap Plate .....	121
Replace Fuse .....	122

## Cleaning Schedule

The recommended cleaning schedule is shown in [Table 13](#). See the following pages for specific procedures.

---

**Caution** • Use only the cleaning agents indicated. Zebra is not responsible for damage caused by any other fluids being used on this printer.

---

**Table 13 • Recommended Printer Cleaning Schedule**

Area	Method	Interval
Printhead	Solvent*	Perform these procedures at the following times: <ul style="list-style-type: none"><li>• When <b>CLEAN HEAD NOW</b> appears.</li><li>• <b>Direct Thermal Print Mode:</b> After every roll of labels or 500 ft (150 m) of fanfold labels.</li><li>• <b>Thermal Transfer Print Mode:</b> After every roll (1500 ft or 450 m) of ribbon.</li></ul>
Platen roller	Solvent*	
Transmissive (media) sensor	Air blow	
Media path	Solvent*	
Ribbon sensor	Air blow	
Label-available sensors	Air blow	Monthly
Tear-off bar	Solvent*	
Snap plate	Solvent*	As needed

\* Use Preventative Maintenance kit, part number 47362, or a solution of 90% isopropyl alcohol and 10% deionized water.

## Clean Exterior

Clean the outside surfaces of the printer with a lint-free cloth. Use a mild detergent solution or desktop cleaner sparingly, as needed.

---

**Caution** • Do not use harsh or abrasive cleaning agents or solvents.

---



## Clean Interior

After every four rolls of media, inspect the inside of the printer. Use a soft bristle brush or a vacuum cleaner to remove any dirt and lint from the interior of the printer.

### Printhead and Platen Roller

After every roll of ribbon, clean the printhead. Clean the printhead more often if you see inconsistent print quality, such as voids in the bar code or graphics.

Clean after every roll (1500 feet or 450 m) of thermal transfer ribbon or after every roll (500 feet or 150 m) of direct thermal labels or when **CLEAN HEAD NOW** appears on the LCD.



**Note** • You do not need to turn off the printer before cleaning the printhead. If power is turned off, all label formats and images, as well as any temporarily saved parameter settings stored in the printer's internal memory, are lost. When power is turned back on, these items must be reloaded.

If print quality does not improve after you perform this procedure, clean the printhead with *Save-a-Printhead* cleaning film. This specially coated material removes contamination buildup without damaging the printhead. Call your authorized Zebra reseller or distributor for more information.



---

**Caution** • The printhead is hot and can cause severe burns. Allow the printhead to cool.

---



---

**Caution** • Observe proper electrostatic safety precautions when handling any static-sensitive components such as circuit boards and printheads.

---

#### To clean the printhead and platen roller, complete these steps:

1. Open the printhead.
2. Remove the media and ribbon (if loaded).
3. Use Preventative Maintenance kit, part number 47362 or a solution of 90% isopropyl alcohol and 10% deionized water on an applicator to wipe along the print elements from end to end, as shown in [Figure 44](#). (The print elements are on the brown strip on the printhead.) Allow a few seconds for the solvent to evaporate.

Figure 44 • Cleaning the Printhead

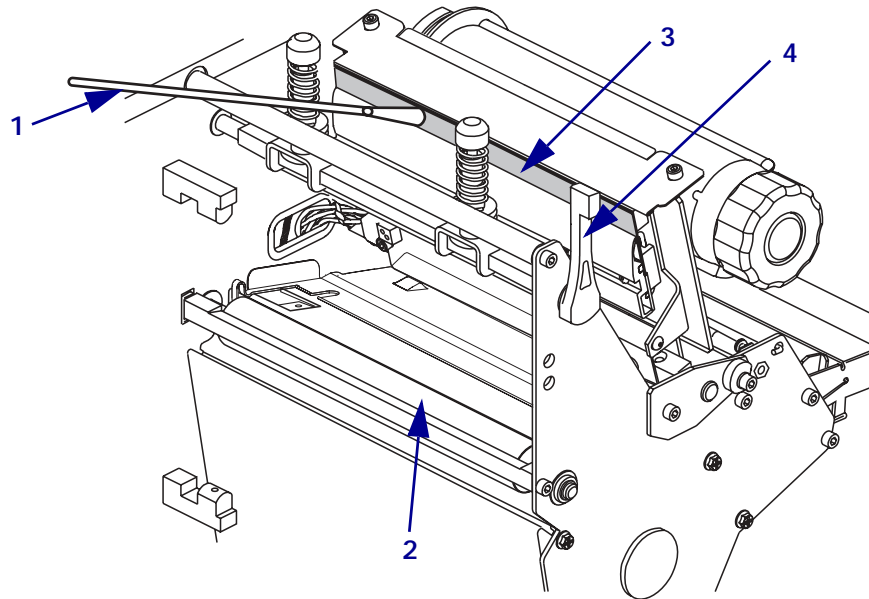

1	Applicator
2	Platen roller
3	Printhead print elements
4	Printhead lever

4. Rotate the platen roller and clean thoroughly with solvent and an applicator.
5. Brush or vacuum any accumulated paper lint and dust away from the rollers.
6. Reload the media and the ribbon (if required).
7. Close the printhead.

## Sensors

Brush or vacuum any accumulated paper lint and dust off the sensors whenever the sensors are blocked. At minimum, clean the sensors according to the recommendations in [Cleaning Schedule](#) on page 116.

### Ribbon and Label-Available Sensor Locations

The ribbon sensor and optional label-available sensor are shown in [Figure 45](#).

Figure 45 • Sensor Locations

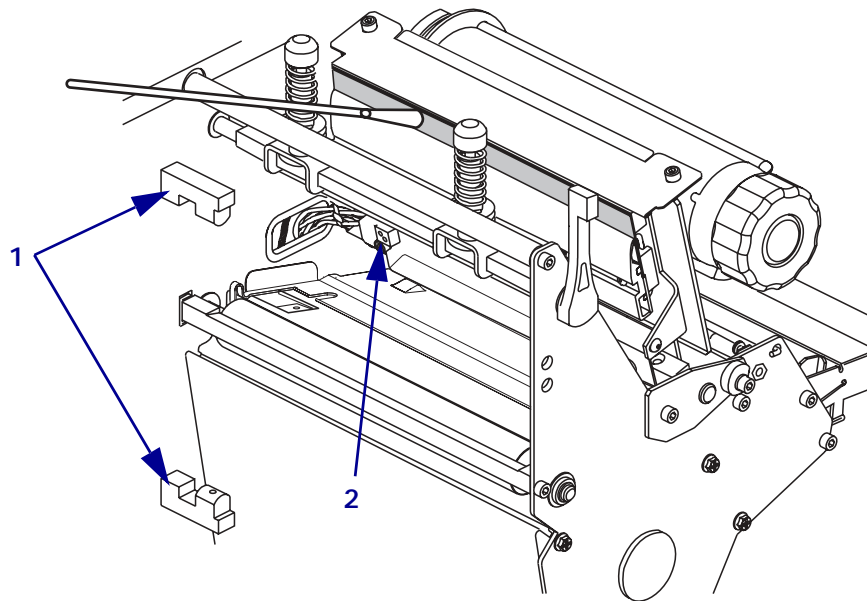

1	Label-available sensors
2	Ribbon sensor

## Transmissive (Media) Sensor Locations

The locations of the upper and lower transmissive (media) sensors are shown in [Figure 46](#) and [Figure 47](#).

**Figure 46 • Upper Media Sensor**

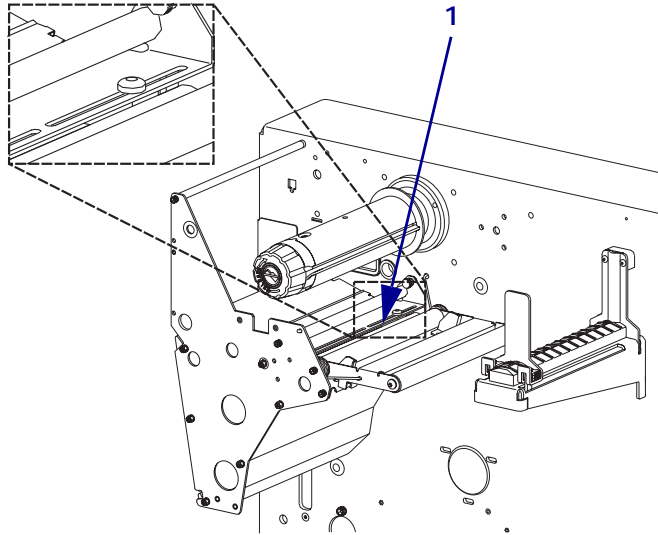

---

1	Upper media sensor
---	--------------------

---

**Figure 47 • Lower Media Sensor**

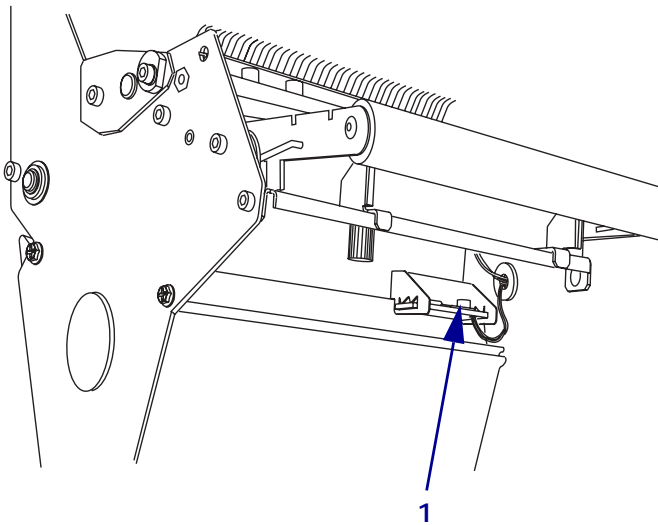

---

1	Lower media sensor
---	--------------------

---

## Snap Plate

Clean the snap plate when label adhesive or a label is stuck to the underside. [Figure 48](#) shows the location of the snap plate

**Figure 48 • Snap Plate Location**

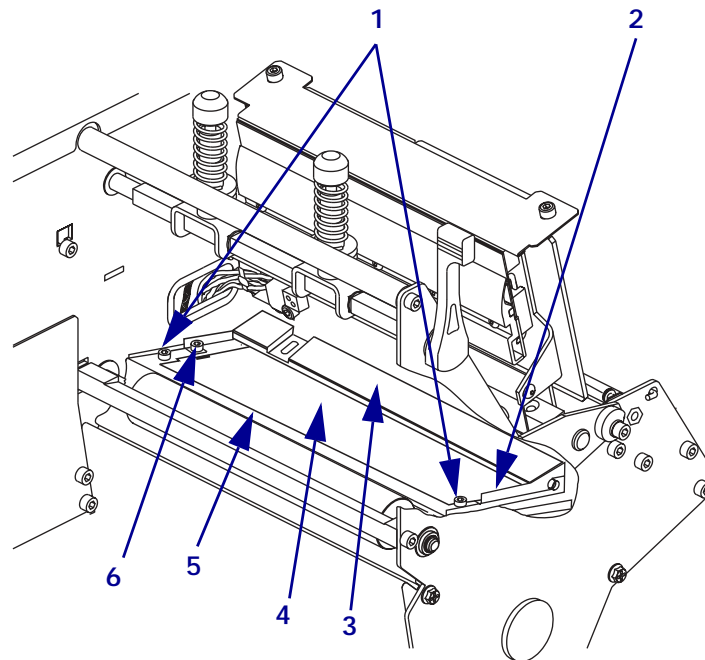

1	Antenna support screws
2	Location of right-side snap plate screw (screw not shown)
3	Snap plate
4	Antenna support
5	Antenna support frame
6	Left-side snap plate screw

### To clean the snap plate, complete these steps:

1. Remove the two screws that secure the snap plate to the antenna support frame.



**Important** • Do not remove the antenna support screws.

2. Remove the snap plate from the printer.
3. Clean the snap plate with cleaning solvent and a soft cloth.
4. To reinstall the snap plate, slide it back into place until the screw holes on the snap plate line up with the screw holes in the antenna support frame.
5. Reinstall the two snap plate screws to secure the snap plate to the antenna support frame.

## Replace Fuse

The R110Xi fuse must be replaced only by an authorized service technician.



**Caution** • Turn the AC power switch Off (O) and remove the power cord before performing this procedure.

The printer uses a metric-style fuse (5 × 20 mm IEC) rated at F5A, 250 V. The AC power entry module comes with two approved fuses in the fuse holder: one is in-circuit, and the second is provided as a spare. The end caps of the fuse must bear the certification mark of a known international safety organization (see [Figure 7 on page 11](#)).

### To replace a faulty fuse, complete these steps:

1. Use a small-blade screwdriver or similar tool to remove the fuse holder.

The fuse holder is part of the AC power entry module at the rear of the printer ([Figure 49](#)).

**Figure 49 • AC Power Entry Module**

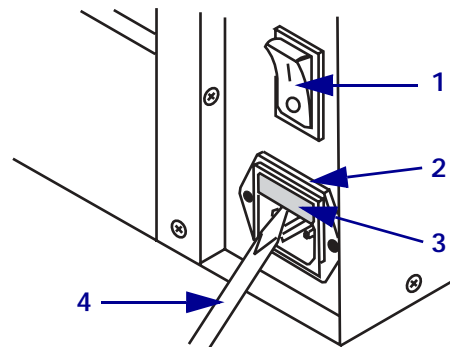

1	Power switch
2	Fuse holder
3	AC power entry module
4	Small-blade screwdriver

2. Remove the faulty fuse and install a new fuse in the in-circuit position ([Figure 50](#)).



**Important** • If you use the spare fuse, be sure to order a replacement fuse from your authorized Zebra distributor. The spare fuse should be the exact type and rating as the original in-circuit fuse.

Figure 50 • Fuse Locations

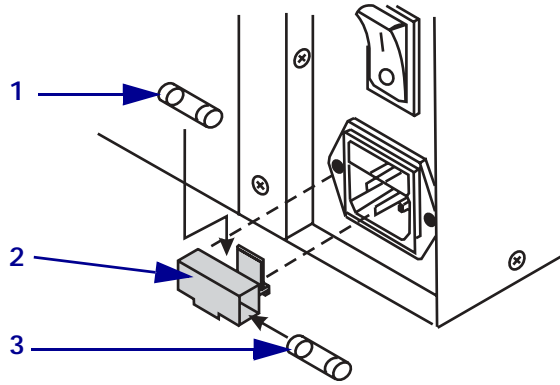

1	In-circuit fuse
2	Fuse holder
3	Spare fuse

3. Snap the fuse holder back into the AC power entry module.
4. Reconnect the power cord, and turn the printer On (I).



**Note** • If the printer does not power on, an internal component failure may have occurred, and the printer requires servicing by an authorized service technician.







---

# Troubleshooting

This chapter provides you with information about LCD, print quality, communications, and other errors that you might need to troubleshoot.

## Contents

Troubleshooting . . . . .	126
LCD Error Messages . . . . .	127
Print Quality Problems . . . . .	130
Communications Problems . . . . .	132
Printer Diagnostics . . . . .	134
Power-On Self Test . . . . .	134
Additional Printer Self Tests . . . . .	134
Communications Diagnostics Test . . . . .	139
Additional Printer Diagnostics . . . . .	139

## Troubleshooting

### **If an error condition exists with the printer, review this checklist:**

- Is there an error message on the LCD? If yes, see [LCD Error Messages on page 127](#) for more information.
- Is the CHECK RIBBON light on when ribbon is loaded properly, or are non-continuous labels being treated as continuous labels? If yes, see [Calibrate Media and Ribbon Sensors on page 50](#).
- Are you experiencing problems with print quality? If yes, see [Print Quality Problems on page 130](#).
- Are you experiencing communications problems? If yes, see [Communications Problems on page 132](#).

### **If the labels are not printing or advancing correctly, review this checklist:**

- Are you using the correct type of labels? Review the types of label in [Types of Media on page 14](#).
- Review the label- and ribbon-loading illustrations, starting with [Loading the Media on page 20](#).
- Check the position of the media sensor and move if necessary, as shown in [Adjust Media Sensors on page 37](#).
- Does the printhead need to be adjusted? See [Adjust Printhead Pressure and Toggle Position on page 39](#) for more information.
- Do the sensors need to be calibrated? See [Calibrate Media and Ribbon Sensors on page 50](#) for more information.

### **If none of the above suggestions correct the problem, review this checklist:**

- Perform one or more of the self-tests given in [Printer Diagnostics on page 134](#). Use the results to help identify the problem.
- If you are still having problems, see [Support on page x](#) for customer support information.

## LCD Error Messages

The LCD displays messages when there is an error. See [Table 14](#) for LCD errors, the possible causes, and the recommended solutions.

**Table 14 • LCD Error Messages**

LCD	Possible Cause	Recommended Solution
RIBBON OUT	Thermal Transfer Mode— Ribbon is not loaded or is loaded incorrectly.	Load the ribbon correctly, following directions in <a href="#">Loading Ribbon on page 26</a> .
	Thermal Transfer Mode— Ribbon is loaded but the ribbon sensor is not sensing the ribbon.	Adjust the media and ribbon sensors. See <a href="#">Calibrate Media and Ribbon Sensors on page 50</a> .
	Direct Thermal Mode— Ribbon is loaded.	Make sure that ribbon is not loaded and that the printer is in Direct Thermal Print Mode. See <a href="#">Selecting Print Method on page 46</a> .
	Direct Thermal Mode— Settings are incorrect.	Make sure the printer driver and software settings are compatible with Direct Thermal Print Mode.
PAPER OUT	Labels are not loaded or are loaded incorrectly.	Load the labels correctly. See <a href="#">Loading the Media on page 20</a> .
	Media Sensor is not adjusted correctly.	Check the position of the media sensors, and adjust if necessary. See <a href="#">Calibrate Media and Ribbon Sensors on page 50</a> .
	Printer is set for non-continuous labels but continuous labels are loaded.	<ul style="list-style-type: none"> <li>• Make sure the labels and the Media Type settings match. See <a href="#">Setting Media Type on page 45</a>.</li> <li>• Make sure the printer driver or software settings match the label and Media Type settings.</li> <li>• Calibrate the printer. For more information, see <a href="#">Calibrate the Printer on page 35</a>.</li> </ul>
	The MAX LENGTH setting is set to a value that is shorter than the actual length of the label.	Change the MAX LENGTH setting to a value that is at least 1 in. (25 mm) longer than the labels.
HEAD OPEN	The printhead is not fully closed.	Close the printhead.
HEAD ELEMENT BAD	One or more of the printhead elements failed the printhead element test.	<ul style="list-style-type: none"> <li>• If the failed elements affect your printing application, replace the printhead.</li> <li>• To override this error, disable the head test count feature on the front panel by defaulting the value to <b>0000</b>.</li> </ul>

**Table 14 • LCD Error Messages (Continued)**







LCD	Possible Cause	Recommended Solution
RIBBON IN	Ribbon is loaded, but the printer is set for Direct Thermal mode.	<ul style="list-style-type: none"> <li>• To operate in Direct Thermal mode, remove the ribbon.</li> <li>• To operate in Thermal Transfer mode, leave the ribbon loaded and change the print method to Thermal Transfer. See <a href="#">Selecting Print Method on page 46</a>.</li> <li>• Ensure that the printer driver and/or software settings are correctly set (if applicable).</li> </ul>
HEAD TOO HOT	The printhead is over temperature.	<p>Printing automatically resumes when the printhead elements cool to an acceptable operating temperature.</p> <p> <b>Caution</b> • The printhead is hot and can cause severe burns. Allow the printhead to cool.</p> <p> <b>Caution</b> • Observe proper electrostatic safety precautions when handling any static-sensitive components such as circuit boards and printheads.</p>
CLEAN HEAD NOW	The printhead requires cleaning.	<p>Clean the printhead according to the instructions in <a href="#">Printhead and Platen Roller on page 117</a>.</p> <p> <b>Caution</b> • The printhead is hot and can cause severe burns. Allow the printhead to cool.</p> <p> <b>Caution</b> • Observe proper electrostatic safety precautions when handling any static-sensitive components such as circuit boards and printheads.</p> <p>If the message does not go away after the printhead is cleaned, open the printhead and then close it.</p>

Table 14 • LCD Error Messages (Continued)

LCD	Possible Cause	Recommended Solution
HEAD COLD	 <b>Caution</b> • An improperly connected printhead data or power cable can cause this error message. The printhead can still be hot enough to cause severe burns. Allow the printhead to cool.	
	The printhead is under temperature.	Continue printing while the printhead reaches the correct operating temperature. If the error remains, the environment may be too cold for proper printing. Relocate the printer to a warmer area.
	Printhead data cable is not properly connected.	<b>Caution</b> • You must turn off the printer before performing this procedure. Failure to do so can damage the printhead. <ol style="list-style-type: none"> <li>1. Turn off (O) the printer.</li> <li>2. Disconnect and reconnect the data cable to the printhead.</li> <li>3. Ensure that the cable connector is fully inserted into the printhead connector.</li> <li>4. Turn on (I) the printer.</li> </ol>  <b>Caution</b> • Observe proper electrostatic safety precautions when handling any static-sensitive components such as circuit boards and printheads.
OUT OF MEMORY	There is not enough memory to perform the function shown on the second line of the error message.	Turn the printer off then back on to clear memory, and try to print again. If the error recurs, there is insufficient memory for the label length, downloaded fonts or graphics, and images.
		Ensure that the device, such as Flash memory or PCMCIA card, is installed and not write-protected or full. See <a href="#">Memory Cards on page 109</a> .  <b>Caution</b> • Observe proper electrostatic safety precautions when handling any static-sensitive components such as circuit boards and printheads.
		Ensure that the data is not directed to a device that is not installed or available.

## Print Quality Problems

Table 15 identifies problems with print quality, the possible causes, and the recommended solutions.

**Table 15 • Print Quality Problems**









Problem	Possible Cause	Recommended Solution
<b>General print quality issues</b>	You are using an incorrect combination of labels and ribbon for your application.	Consult your authorized Zebra reseller or distributor for information and advice.
	The printer is set at the incorrect print speed.	For optimal print quality, set the print speed to the lowest possible setting for your application via ZPL II, the driver, or the software. See <a href="#">Adjusting Print Speed on page 44</a> .
	The printer is set at an incorrect darkness level.	For optimal print quality, set the darkness to the lowest possible setting for your application via the front panel, the driver, or the software. See <a href="#">Adjusting Print Darkness on page 44</a> .
	The printhead is dirty.	Clean the printhead according to the instructions in <a href="#">Printhead and Platen Roller on page 117</a> .  <b>Caution</b> • The printhead is hot and can cause severe burns. Allow the printhead to cool.  <b>Caution</b> • Observe proper electrostatic safety precautions when handling any static-sensitive components such as circuit boards and printheads.
<b>There is light printing (or no printing) on the left or right side of the label or the printed image is not sharp.</b>	The toggle pressure needs to be adjusted.	Follow the instructions in <a href="#">Adjust Printhead Pressure and Toggle Position on page 39</a> .  <b>Caution</b> • Observe proper electrostatic safety precautions when handling any static-sensitive components such as circuit boards and printheads.
<b>Gray lines on blank labels with no consistent pattern</b>	The printhead is dirty.	Clean the printhead according to the instructions in <a href="#">Printhead and Platen Roller on page 117</a> .  <b>Caution</b> • The printhead is hot and can cause severe burns. Allow the printhead to cool.  <b>Caution</b> • Observe proper electrostatic safety precautions when handling any static-sensitive components such as circuit boards and printheads.

Table 15 • Print Quality Problems (Continued)

Problem	Possible Cause	Recommended Solution
<b>Light, consistent vertical lines running through the labels</b>	The printhead or platen roller is dirty.	Clean the printhead and platen roller as instructed in <i>Printhead and Platen Roller</i> on page 117.
		 <b>Caution</b> • The printhead is hot and can cause severe burns. Allow the printhead to cool.  <b>Caution</b> • Observe proper electrostatic safety precautions when handling any static-sensitive components such as circuit boards and printheads.
<b>Intermittent creases on the left and right edges of the labels</b>	There is too much toggle pressure on the printhead.	Reduce the toggle pressure. See <i>Adjust Printhead Pressure and Toggle Position</i> on page 39.  <b>Caution</b> • Observe proper electrostatic safety precautions when handling any static-sensitive components such as circuit boards and printheads.
<b>Wrinkled ribbon</b>	The ribbon is not loaded correctly.	Load the ribbon correctly. See <i>Loading Ribbon</i> on page 26.
	The darkness setting is incorrect.	Set the darkness to the lowest possible setting for good print quality. See <i>Adjusting Print Darkness</i> on page 44.
	Incorrect printhead pressure or balance.	Set the pressure to the minimum required for good print quality. See <i>Adjust Printhead Pressure and Toggle Position</i> on page 39.  <b>Caution</b> • Observe proper electrostatic safety precautions when handling any static-sensitive components such as circuit boards and printheads.
	The labels are not feeding correctly. They are shifting from side to side.	Make sure that the media guide and media supply guide touch the edge of the media.
Adjust the ribbon strip plate.		

## Communications Problems

Table 16 identifies problems with communications, the possible causes, and the recommended solutions.

**Table 16 • Communications Problems**

Problem	Possible Cause	Recommended Solution
A label format was sent to the printer but was not recognized. The DATA light does not flash.	The communication parameters are incorrect.	Check the printer driver or software communications settings (if applicable).
		If you are using serial communication, check the serial port setting in the front panel menu. See <a href="#">Setting Serial Communications on page 50</a> .
		Make sure you are using the correct communication cable. See <a href="#">Data Cable Requirements on page 13</a> for the requirements.
		Using the front panel controls, check the protocol setting. It should be set to <b>NONE</b> . See <a href="#">Setting Protocol on page 51</a> .
		If a driver is used, check the driver communication settings for your connection.
A label format was sent to the printer. Several labels print, then the printer skips, misplaces, misses, or distorts the image on the label.	The host is set to EPP parallel communications.	Change the settings on the computer host to standard parallel communications. See <a href="#">Setting Parallel Communications on page 50</a> .
	The serial communication settings are incorrect.	Ensure that the flow control settings match.
		Check the communication cable length. See <a href="#">Data Cable Requirements on page 13</a> for requirements.
A label format was sent to the printer but was not recognized. The DATA light flashes but no printing occurs.	The prefix and delimiter characters set in the printer do not match the ones in the label format.	Verify the prefix and delimiter characters. See <a href="#">Format Prefix Character on page 53</a> and <a href="#">Delimiter Character on page 53</a> for the requirements.
		Incorrect data is being sent to the printer.
		Ensure that ZPL is being used.
		Check the communication settings on the computer. Ensure that they match the printer settings.



## Miscellaneous Printing Problems

**Table 17 • Miscellaneous Printing Problems**

Problem	Possible Cause	Recommended Solution
<b>The printer fails to calibrate or detect the top of the label.</b>	The printer was not calibrated for the label being used.	Press PAUSE on the front panel to pause the printer, and then press CALIBRATE.
	The printer is configured for continuous media.	Set the media type to non-continuous media. See <a href="#">Setting Media Type on page 45</a> .
	The driver or software configuration is not set correctly.	Driver or software settings produce ZPL commands that can overwrite the printer configuration. Check the driver or software media-related setting.
<b>RFID labels are not calibrating correctly. The label is positioned so that it cannot be torn off at the correct location.</b>	The printer sometimes mistakes the antenna or chip as the leading edge of the label.	<ol style="list-style-type: none"> <li>1. Press PAUSE on the front panel to pause the printer, and then press CALIBRATE.</li> <li>2. If this does not solve the problem, remove one or two labels from the backing and position the backing under the upper media sensor (see <a href="#">Adjust Media Sensors on page 37</a> for the location). Press PAUSE on the front panel to pause the printer, and then press CALIBRATE.</li> <li>3. If this does not solve the problem, calibration may need to be performed using non-RFID labels that are the same size as the RFID labels being used. Before reloading the RFID labels, select FEED or LENGTH for the <b>MEDIA POWER UP</b> and <b>HEAD CLOSE</b> parameters (see <a href="#">Media Power Up on page 54</a> and <a href="#">Head Close on page 54</a>).</li> </ol>

## Printer Diagnostics

Self tests give information about the condition of the printer. The most commonly used are the Power-On and the CANCEL self tests.

---

**Caution** • Be sure that the print width is set to match the label width you are using before running any self tests. If the labels are not wide enough, the test may print on the platen roller and damage it.

---

### Power-On Self Test

The Power-On Self Test (POST) is performed automatically each time the printer is turned on. During either test sequence, the front panel LEDs light up and the LCD monitors the progress of the POST. If the printer fails any of these tests, **FAI LED** shows on the LCD. If this occurs, notify an authorized Zebra reseller.

### Additional Printer Self Tests

These self tests produce sample printouts and provide specific information that help determine the operating conditions for the printer.

Each self test is enabled by pressing a specific front panel key or combination of keys while turning the power On (**I**). Keep the key(s) depressed until the **DATA** light turns off. When the POST is complete, the selected self test starts automatically.



**Note** • When performing a self test, do not send a label format to the printer. For remote hosts, disconnect all data interface cables from the printer. For printers in Peel-Off Mode, remove the labels as they come out of the printer.

## CANCEL Self Test

The CANCEL self test prints a printer configuration label, which tells you the current settings for the printer.

### To perform the CANCEL Self Test, complete these steps:

1. Turn Off (O) the printer.
2. Press and hold CANCEL while turning the power On (I). Hold CANCEL until the DATA light turns off.

A printer configuration label prints (Figure 51).

Figure 51 • Printer Configuration Label





## PAUSE Self Test

This self test can be used to provide the test labels required when making adjustments to the printer's mechanical assemblies. See the sample printout below.

### To perform a PAUSE self test, complete these steps:

1. Turn Off (O) the printer.
2. Press and hold PAUSE while turning the power On (I). Hold PAUSE until the DATA light turns off.
  - The initial self test prints 15 labels at 2.4 in. (61 mm) per second, then automatically pauses the printer. When PAUSE is pressed, an additional 15 labels print. [Figure 52](#) shows a sample of the labels.

**Figure 52 • PAUSE Test Label**

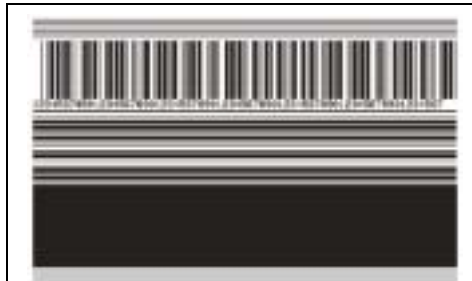

- While the printer is paused, pressing CANCEL alters the self test. When PAUSE is pressed, 15 labels print at 6 in. or 152 mm per second.
- While the printer is paused, pressing CANCEL again alters the self test a second time. When PAUSE is pressed, 50 labels print at 2.4 in. (61 mm per second).
- While the printer is paused, pressing CANCEL again alters the self test a third time. When PAUSE is pressed, 50 labels print at 6 in. (152 mm) per second.
- While the printer is paused, pressing CANCEL again alters the self test a fourth time. When PAUSE is pressed, 15 labels print at the printer's maximum speed.
- To exit this self test at any time, press and hold CANCEL.

## FEED Self Test

This test helps you choose the best darkness setting for your printer.

### To perform a FEED self test, complete these steps:

1. Turn Off (O) the printer.
2. Press and hold FEED while turning the power On (I). Hold FEED until the DATA light turns off.

The printer prints a series of labels (Figure 53) at various speeds and at darkness settings higher and lower than the darkness value shown on the configuration label.

**Figure 53 • FEED Test Label**



3. Inspect the labels and determine which one has the best print quality for your application. The darkness value printed on that label is added to (plus) or subtracted from (minus) the darkness value specified on the configuration label. The resulting numeric value (0 to 30) is the best darkness value for that specific label/ribbon combination and print speed.
4. Enter the corresponding darkness and print speed values into the printer through the front panel.

## FEED and PAUSE Self Test

Performing this self test temporarily resets the printer configuration to the factory default values. These values are active only until power is turned off unless you save them permanently in memory.

**To perform a FEED and PAUSE self test, complete these steps:**

1. Turn Off (O) the printer.
2. Press and hold FEED and PAUSE while turning the power On (I). Hold FEED and PAUSE until the DATA light turns off.  
No labels print at the end of this test.

## Communications Diagnostics Test

This test is controlled from the front panel display. See [Setting Communications Mode on page 52](#). [Figure 54](#) shows a typical printout from this test. Turn off the power to exit this self test and return to normal operation.



**Note** • The communications test label prints upside-down.

**Figure 54 • Communications Diagnostics Test Label**

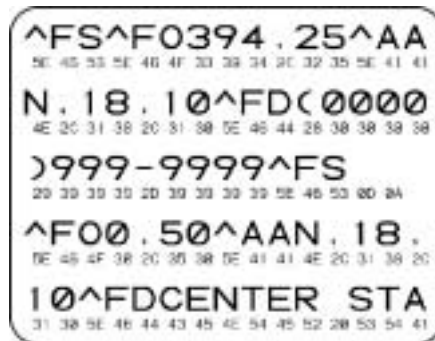

## Additional Printer Diagnostics

Additional diagnostic tests are available for this printer. See the *Maintenance Manual* for information about these additional tests.







---

# Specifications

This appendix provides the features of and specifications for the R110Xi/R170Xi printers.

## Contents

Features . . . . .	142
Standard Features . . . . .	142
Print Modes . . . . .	142
Zebra Programming Language (ZPL II®) . . . . .	142
Bar Codes . . . . .	143
Agency Approvals . . . . .	143
General Specifications . . . . .	144
Electrical Specifications . . . . .	144
Environmental Conditions for Operation and Storage . . . . .	144
Print Specifications by Model . . . . .	145
Ribbon Specifications by Model . . . . .	147
Label Specifications . . . . .	148

## Features

This section lists the standard and optional features for the printer.

### Standard Features



**Note** • Printer specifications are subject to change without notice.

- Thermal transfer and direct thermal printing
- DRAM 16 MB
- USB 2.0 Port
- Real-time Clock
- Advanced Counter

### Print Modes

Five different print modes can be used, depending on the printer options purchased:

- **Tear-Off Mode:** Labels are produced in strips.
- **Peel-Off Mode:** Labels are dispensed and peeled from the backing as needed.
- **Applicator Mode:** The printer is part of a larger label application system.

### Zebra Programming Language (ZPL II®)

ZPL features include:

- Downloadable graphics, scalable and bitmap fonts, and label formats
- Object copying between memory areas
- (RAM, memory card, and internal Flash)
- Code page 850 character set
- Data compression
- Automatic virtual input buffer management
- Format inversion
- Mirror image printing
- Four-position field rotation (0°, 90°, 180°, 270°)
- Slew command
- Controlled via mainframe, mini-computer, PC, portable data terminal
- Programmable quantity with print, pause, and cut control
- Communicates in printable ASCII characters
- Error-checking protocol
- Status message to host upon request
- Serialized fields
- In-spec OCR-A and OCR-B
- UPC/EAN
- User-programmable password

## Bar Codes

Types of bar codes include:

- Bar code ratios—2:1, 7:3, 5:2, 3:1
- Codabar (supports ratios of 2:1 up to 3:1)
- CODABLOCK
- Code 11
- Code 39 (supports ratios of 2:1 up to 3:1)
- Code 49 (two-dimensional bar code)
- Code 93
- Code 128 (with subsets A, B, and C and UCC case codes)
- Check digit calculation where applicable
- Data Matrix
- EAN-8, EAN-13, EAN extensions
- ISBT-128
- Industrial 2 of 5
- Interleaved 2 of 5 (supports ratios of 2:1 up to 3:1, Modulus 10 Check Digit)
- LOGMARS
- MaxiCode
- Micro PDF
- MSI
- PDF-417 (2-dimensional bar code)
- PLANET code
- Plessey
- POSTNET
- QR-Code
- RSS code
- Standard 2 of 5
- TLC 39
- UPC-A, UPC-E, UPC extensions

## Agency Approvals

Approvals include:

- Binational UL 60950 3rd edition/CSA CAN/CSA-C22.2 No. 60950-00 3rd edition
- FCC Part 15.107 and 15.109 Class B
- FCC Part 15.247
- Canadian ICES-003, Class B
- IC RSS-210

## General Specifications

<b>Dimensions</b>	<b>R110Xi</b>	<b>R170Xi</b>
Height	15.5 in. (393.7 mm)	15.5 in. (393.7 mm)
Width	10.37 in. (263.5 mm)	13.15 in. (334.4 mm)
Depth	19.5 in. (495.3 mm)	19.5 in. (495.3 mm)
Weight without options	51 lb. (25 kg)	67 lb. (30.5 kg)

## Electrical Specifications

<b>Power</b>	<b>R110Xi</b>	<b>R170Xi</b>
General	90 to 264 VAC; 48 to 62 Hz	90 to 264 VAC; 48 to 62 Hz
Power consumption printing PAUSE test at slowest speed	180 W	220 W
Printer idle	20 W	20 W

## Environmental Conditions for Operation and Storage

<b>Environment</b>	<b>Mode</b>	<b>Temperature</b>	<b>Relative Humidity</b>
Operation	Thermal Transfer	41° to 104°F (5° to 40° C)	20 to 85% non-condensing
	Direct Thermal	32° to 104°F (0° to 40° C)	
Storage	Thermal Transfer or Direct Thermal	-40° to 140°F (-40° to 60° C)	5 to 85% non-condensing

## Print Specifications by Model

Refer to the key and the table that follows for printer specifications.

**Model Specifications Key** This table contains the key for print specifications for the tables that follows.

■	Non-Continuous printing (gap, notch, or hole between labels).
■	Continuous printing (no gap, notch or hole).
◆	Ladder (rotated) orientation.
◇	Picket fence (nonrotated) orientation.

### R110Xi

Print Specifications	R110Xi 200 dpi	R110Xi 300 dpi
Printhead resolution	203 dots/inch (8 dots/mm)	300 dots/inch (12 dots/mm)
Dot size (width×length)	0.0049×0.0049 in. (0.125×0.125 mm)	0.0033×0.0033 in. (0.084×0.084 mm)
First dot location (measured from inside media edge)	0.10 ± 0.035 in. (2.5 ± 0.89 mm)	0.023 ± 0.035 in. (0.6 ± 0.9 mm)
Maximum print width	4.09 in. (104 mm)	4.09 in. (104 mm)
Selectable print speeds (inches per second)	2.4, 3 through 10	2.4, 3 through 8
Maximum Print length	39 in. (991 mm) ■ 150 in. (3810 mm) ■■	39 in. (991 mm) ■ 100 in. (3810 mm) ■■
Bar code modulus (X) dimension	4.9 mil to 49 mil ◆ 4.9 mil to 49 mil ◇	3.9 mil to 39 mil ◆ 3.33 mil to 33 mil ◇
Thin film printhead with Element Energy Equalizer (E <sup>3</sup> ) <sup>®</sup>	Yes	Yes

**Specifications**

## Print Specifications by Model

**R170Xi**

<b>Print Specifications</b>	<b>170Xi 200 dpi</b>	<b>170Xi 300 dpi</b>
Printhead resolution	203 dots/inch (8 dots/mm)	300 dots/inch (12 dots/mm)
Dot size (width×length)	0.0049×0.0049 in. (0.125×0.125 mm)	0.0033×0.0033 in. (0.084×0.084 mm)
First dot location (measured from inside media edge)	0.10 ± 0.035 in. (2.5 ± 0.89 mm)	0.10 ± 0.035 in. (2.5 ± 0.89 mm)
Maximum print width	6.6 in. (168 mm)	6.6 in. (168 mm)
Selectable print speeds (in. per second)	2.4, 3, 4, 5, 6, 7, 8, 9, 10, 11, 12	2.4, 3, 4, 5, 6, 7, 8
Maximum print length	39 in. (99 cm) ■ 100 in. (381 cm) ■■	39 in. (99 cm) ■ 100 in. (254 cm) ■■
Bar code modulus (X) dimension	3.9 mil to 39 mil ◆ 3.33 mil to 33 mil ◇	3.9 mil to 39 mil ◆ 3.33 mil to 33 mil ◇
Thin film printhead with Element Energy Equalizer (E3)	Yes	Yes

## Ribbon Specifications by Model

Refer to the table that follows for ribbon specifications for your type of printer.



**Note** • Match the ribbon to the label width and printhead width that you are using.

- Ribbon must be wound with the coated side out.
- Ribbon should be at least as wide as the labels to protect the printhead from excessive wear.

Ribbon Specifications	R110Xi	R170Xi
Printhead resolution	203 dots/inch (8 dots/mm)	300 dots/inch(12 dots/mm)
Ribbon width—Minimum*	0.79 in. (20 mm)	2.0 in. (51 mm)
Ribbon width—Maximum	4.33 in. (110 mm)	6.7 in. (170 mm)
Standard length with 2:1 label to ribbon ratio	984 ft (300 m)	984 ft (300 m)
Standard length with 3:1 label to ribbon ratio	1476 ft (450 m)	1476 ft (450 m)
Ribbon core inside diameter	1.0 in. (25.4 mm)	1.0 in. (25.4 mm)
Maximum ribbon roll outside diameter	3.2 in. (81.3 mm)	3.2 in. (81.3 mm)

\* For RFID labels, the minimum ribbon width is determined by the minimum label width for the transponder being used. For the list of approved transponders, go to <http://www.rfid.zebra.com>.

## Label Specifications

R110Xi/R170Xi printers need the correct size and type of labels for best performance. Refer to the tables that follow for the specifications.



**Important** • Media registration and minimum label length are affected by label type and width, ribbon type, print speed, and printer mode of operation. Performance improves as these factors are optimized. Zebra recommends qualifying any application with thorough testing.













Label Specifications		R110Xi	R170Xi
Minimum label length	Tear-off	0.7 in. (18 mm)*	0.7 in. (18 mm)*
	RFID labels	**	**
Total media width (label + backing, if any)	Minimum	0.79 in. (20 mm)*	2.00 in. (51 mm)
	Maximum	4.5 in. (114 mm)	7.1 in. (180 mm)
	RFID labels	**	**
Total thickness (includes backing, if any)	Minimum	0.003 in. (0.076 mm)	0.003 in. (0.076 mm)
	Maximum	0.012 in. (0.305 mm)	0.012 in. (0.305 mm)
Roll media core inside diameter		3 in. (76 mm)	3 in. (76 mm)
Maximum roll diameter on 3 in. (76 mm) core		8.0 in. (203 mm)	8.0 in. (203 mm)
Interlabel gap	Minimum	0.079 in. (2 mm)*	
	Preferred	0.118 in. (3 mm)*	
	Maximum	No more than the calibrated length of the label.	No more than the calibrated length of the label.
	RFID labels	**	**
Maximum internal fanfold media pack size (label + backing) L × W × H	R110Xi 200 dpi	8.0×4.5×4.5 in. (20×114×114 mm)	8.0×7.1×4.5 in. (203×114×114 mm)
	R110Xi 300 dpi	8.0×5.5×4.5 in. (203×140×114 mm)	
Ticket/tag sensing notch L × W		0.12×0.25 in. (3×6 mm)	0.12×0.25 in. (3×6 mm)
Ticket/tag sensing hole diameter		0.125 in. (3 mm)	0.125 in. (3 mm)
Label registration tolerance (vertical)		± 0.06 in. (± 1.5 mm)	± 0.070 in. (± 1.8 mm)
Label registration tolerance (horizontal)		± 0.06 in. (± 1.5 mm)	± 0.070 in. (± 1.8 mm)

\* Does not apply to RFID labels.

\*\* This parameter varies for each transponder type. For the list of approved transponders, go to <http://www.rfid.zebra.com>.



### Black Mark Sensing Only

Label Specifications	R110Xi 200 dpi	R110Xi 300 dpi	R170Xi
Mark length (measuring parallel to label/tag edge)	0.12 in. (3 mm)  0.43 in. (11 mm) 	0.12 in. (3 mm)  0.43 in. (11 mm) 	0.12 in. (3 mm)  0.43 in. (11 mm) 
Mark width (measuring to perpendicular label/tag edge)	0.43 in. (11 mm)  Full media width 	0.43 in. (11 mm)  Full media width 	0.43 in. (11 mm)  Full media width 
Mark location	within 0.040 in. (1 mm) of the inside media edge	within 0.040 in. (1 mm) of the inside media edge	within 0.040 in. (1 mm) of the inside media edge
Mark density in Optical Density Unit (ODU)	>1.0	>1.0	>1.0



**Notes •** \_\_\_\_\_

\_\_\_\_\_

\_\_\_\_\_

\_\_\_\_\_

\_\_\_\_\_

\_\_\_\_\_

\_\_\_\_\_

\_\_\_\_\_

\_\_\_\_\_

\_\_\_\_\_

\_\_\_\_\_

---

# Proprietary Statement



This manual contains proprietary information of Zebra Technologies Corporation and its subsidiaries (“Zebra Technologies”). It is intended solely for the information and use of parties operating and maintaining the equipment described herein. Such proprietary information may not be used, reproduced, or disclosed to any other parties for any other purpose without the expressed written permission of Zebra Technologies.

## Product Improvements

Continuous improvement of products is a policy of Zebra Technologies. All specifications and designs are subject to change without notice.

## FCC Compliance Statement

This device complies with Part 15 rules. Operation is subject to the following two conditions:

1. This device may not cause harmful interference, and
2. This device must accept any interference received, including interference that may cause undesired operation.

This equipment has been tested and found to comply with the limits for Class B Digital Devices, pursuant to Part 15 of the FCC Rules. These limits are designed to provide reasonable protection against harmful interference when the equipment is operated in a residential environment. This equipment generates, uses, and can radiate radio frequency energy and, if not installed and used in accordance with the product manuals, may cause harmful interference to radio communications. However, there is no guarantee that interference will not occur in a particular installation. If this equipment does cause harmful interference to radio or television reception, the user is encouraged to do one or more of the following measures:

- Reorient or relocate the receiving antenna.
- Increase the separation between the equipment and receiver.
- Connect the equipment into an outlet on a circuit different from that to which the receiver is connected.
- Consult the dealer or an experienced radio/TV technician for help.

The user is cautioned that any changes or modifications not expressly approved by Zebra Technologies could void the user's authority to operate the equipment. To ensure compliance, this printer must be used with Shielded Communication Cables.

## **FCC Radiation Exposure Statement**

This equipment complies with FCC radiation exposure limits set forth for an uncontrolled environment. This equipment should be installed and operated with minimum distance 20cm between the radiator and your body.

This transmitter must not be co-located or operating in conjunction with any other antenna or transmitter.

## **Canadian DOC Compliance Statement**

This Class B digital apparatus complies with Canadian ICES-003.

Cet appareil numérique de la classe B est conforme à la norme NMB-003 du Canada.

## **Liability Disclaimer**

Zebra Technologies takes steps to ensure that its published Engineering specifications and manuals are correct; however, errors do occur. Zebra Technologies reserves the right to correct any such errors and disclaims liability resulting therefrom.

## **Limitation of Liability**

In no event shall Zebra Technologies or anyone else involved in the creation, production, or delivery of the accompanying product (including hardware and software) be liable for any damages whatsoever (including, without limitation, consequential damages including loss of business profits, business interruption, or loss of business information) arising out of the use of, the results of use of, or inability to use such product, even if Zebra Technologies has been advised of the possibility of such damages. Some jurisdictions do not allow the exclusion or limitation of incidental or consequential damages, so the above limitation or exclusion may not apply to you.

---

# Warranty Information



## Effective December 30, 2002

All new Zebra products are warranted by the manufacturer to be free from defect in material and workmanship.

## Printers and Related Hardware Products

Proof of purchase or shipment date is required to validate the warranty period. The warranty becomes void if the equipment is modified, improperly installed or used, damaged by accident or neglect, or if any parts are improperly installed or replaced by the user.

Products returned must be packaged in the original or comparable packing and shipping container. In the event equipment is not so packaged, or if shipping damage is evident, it will not be accepted for service under warranty. Surface transportation charges for return to customers in the continental United States is paid by Zebra. Otherwise, Zebra pays CPT (carriage paid to) nearest airport; customer pays customs, duties, taxes, and freight from airport to destination. If Zebra determines that the product returned for warranty service or replacement is not defective as herein defined, the customer will pay all handling and transportation costs.

### Printers

All printers (excluding printheads) are warranted against defect in material or workmanship for twelve (12) months from the purchase date.

## Printheads

Because printhead wear is part of normal operation, the original printhead is covered by a limited warranty as indicated below. Warranty period begins on purchase date.

Printhead	Warranty Period
Bar code label and receipt printer printheads	6 months
Plastic card printer printheads	12 months

To qualify for this warranty, the printhead must be returned to the factory or to an authorized service center. Customers are not required to purchase Genuine Zebra Supplies (media and/or ribbons) for warranty qualification.

However, if it is determined that the use of inappropriate or inferior supplies has caused any defect in the printhead for which a warranty claim is made, the user is responsible for Zebra's labor and material charges required to repair the defect. The warranty becomes void if the printhead is physically worn or damaged; also if it is determined that failure to follow the preventive maintenance schedule listed in the User Guide has caused defect in the thermal printhead for which a warranty claim is made.

## Related Hardware Items

Products are warranted to be free of defects in material and workmanship from the date of purchase according to this chart:

Product	Warranty Period
Accessories	1 month
Batteries	3 months
Cables	1 month
Chargers/Power Supplies	1 year
Hardware Keys	1 year
Keyboard Display Units	6 months
Parts	3 months
Pocket Eye®	1 year
Software	1 month
ZebraNet® Print Servers	3 years

Defective product must be returned to Zebra for evaluation. In the event of notification of defect within the warranty period, Zebra will replace the defective item provided there had not been damage resulting from user abuse, modification, improper installation or use, or damage in shipping or by accident or neglect.

## Supplies Products

Supplies are warranted to be free from defect in material and workmanship for a period of six (6) months for media and twelve (12) months for ribbon from the date of shipment by Zebra. This is provided the user has complied with storage guidelines, handling, and usage of the supplies in Zebra printers.

Zebra's sole obligation under these warranties is to furnish parts and labor for the repair or possible replacement of products found to be defective in material or workmanship during the warranty period. Zebra may in its discretion issue a credit for any such defective products in such amount as it deems reasonable.

## Repair Services

Zebra repairs are warranted against defects in material and workmanship for 90 days from the date of repair by Zebra. This excludes printheads, which are warranted separately. This warranty does not cover normal wear and tear. This warranty becomes void if the item is modified, improperly installed or used, or damaged by accident, neglect, or abuse.

## Warranty Exclusions & Conditions Statement

The warranties given above are the only warranties given to you. No other warranties, express or implied, are given. Zebra does not make any *implied warranty of merchantability or fitness for a particular purpose* in connection with its sale of products or services. While Zebra's desire is to be responsive to your specific needs and questions, Zebra does not assume responsibility for any specific application to which any Products are applied, including, but not limited to, compatibility with other equipment. All statements, technical information, or recommendations relating to Zebra Products are based on tests believed to be reliable, but do not constitute a guaranty or warranty.

Zebra's maximum liability for warranty claims is limited to the invoice price of the Product claimed defective. Zebra does not assume responsibility for delays in replacement or repair of products. Zebra shall not under any circumstances whatsoever be liable to you or any other party for loss or profits, lost data, diminution of goodwill, or any other special or consequential damages whatsoever with respect to any warranty claim made by you. Specifically for software, Zebra is not liable for any incidental or consequential damages caused by abuse or misapplication of the software or by its use in violation of the U.S. copyright law or international treaty. No salesperson, representative, or agent of Zebra is authorized to make any guaranty, warranty, or representation that contradicts the foregoing. Any waiver, alteration, addition, or modification to the foregoing warranties must be in writing and signed by an executive officer of Zebra to be valid.



Zebra Technologies

333 Corporate Woods Parkway

Vernon Hills, IL 60061-3109 U.S.A.

Phone +1 847.634.6700 or +1 800.423.0442

Fax +1 847.913.8766 [www.zebra.com](http://www.zebra.com)





---

# Printer Software and Firmware License Agreement



YOU SHOULD CAREFULLY READ THE FOLLOWING TERMS AND CONDITIONS OF THIS ZEBRA TECHNOLOGIES PRINTER SOFTWARE AND FIRMWARE LICENSE AGREEMENT (PSFLA) BEFORE USING THE PRINTER WHICH IS ENCLOSED OR OTHERWISE ASSOCIATED WITH THIS AGREEMENT. IF YOU DO NOT AGREE WITH THESE TERMS AND CONDITIONS, DO NOT OPERATE THE PRINTER AND PLEASE PROMPTLY RETURN THE PRINTER, ENCLOSURES AND ALL PACKAGING FOR A FULL REFUND.

Zebra Technologies (ZEBRA) hereby grants you a non-exclusive, non-transferable license to use the SOFTWARE and FIRMWARE embedded in the printer and the accompanying documentation according to the following terms:

1. The printer enclosed with or otherwise associated with this Agreement has or includes certain SOFTWARE and FIRMWARE therein which is protected by copyright laws and international copyright treaties, as well as other intellectual property laws and treaties. The SOFTWARE and FIRMWARE is licensed, not sold. Such SOFTWARE and/or FIRMWARE may include, but is not limited to, SOFTWARE and/or FIRMWARE that is licensed under one or more of the following trademarks: ZPL (Zebra Programming Language), ZebraLink, Web View, Web Alert, ZBI (Zebra Basic Interpreter), BAR-ONE, ZTools, Utilities, ZebraNet View for IP, ZebraNet Alert, PC Management Program, ZebraNet View for Networks and ZebraNet Connect.
2. GRANT OF LICENSE. This License grants you the following rights:
  - SOFTWARE and FIRMWARE. You may use, access, display, run, or otherwise interact with (RUN) the SOFTWARE and FIRMWARE in connection with operating the printer which is enclosed with or otherwise associated with this PSFLA (PRINTER). The primary user of the PRINTER may make a second copy for his or her exclusive use on a portable computer/printer.
  - Storage/Network Use. You may also store or install a copy of the SOFTWARE and FIRMWARE on a storage device, such as a network server, used only to RUN the SOFTWARE and FIRMWARE on your other PRINTERS over an internal network; however, you must acquire and dedicate a license for each separate PRINTER on which the SOFTWARE and FIRMWARE is RUN from the storage device. A license for the SOFTWARE and FIRMWARE may not be shared or used concurrently on different PRINTERS.

- Reservation of Rights. All rights not expressly granted are reserved by ZEBRA.
- Accessing Services Using the SOFTWARE and FIRMWARE. Your use of any service accessible using the SOFTWARE and FIRMWARE is not covered by this PSFLA and may be governed by separate terms of use, conditions or notices.

### 3. RESTRICTIONS.

- You must maintain all copyright notices on all copies of the SOFTWARE and FIRMWARE.
- Limitations on modification. You may not modify, adapt, translate, or create derivative works based on this SOFTWARE OR FIRMWARE or the accompanying documentation.
- Limitations of Reverse Engineering, Decompilation and Disassembly. You may not reverse engineer, decompile, or disassemble the SOFTWARE or the FIRMWARE, except and only to the extent that such activity is permitted by applicable law notwithstanding this limitation.
- Rental. You may not rent or lease or lend the SOFTWARE or FIRMWARE.
- Support Services. ZEBRA may provide you with support services related to the SOFTWARE and/or FIRMWARE (SUPPORT SERVICES), in its discretion. Use of SUPPORT SERVICES, if any, is governed by the ZEBRA policies and programs described in the user guide, in online documentation, and/or other ZEBRA provided materials. Any supplemental SOFTWARE or FIRMWARE code provided to you as a part of SUPPORT SERVICES shall be considered part of the SOFTWARE and/or FIRMWARE and is subject to the terms of this PSFLA. With respect to technical information you provide to ZEBRA as part of the SUPPORT SERVICES, ZEBRA may use such information for its business purposes, including for product support and development. ZEBRA will not utilize such technical information in a form that personally identifies you except to the extent necessary to provide you with support.
- Replacement, Modification and Upgrade of the SOFTWARE and/or FIRMWARE. ZEBRA reserves the right to replace, modify or upgrade the SOFTWARE and/or FIRMWARE at any time by offering you a replacement or modified version of the SOFTWARE and/or FIRMWARE or such upgrade and to charge for such replacement, modification or upgrade. Any such replacement or modified SOFTWARE and/or FIRMWARE code or upgrade to the SOFTWARE and/or FIRMWARE offered to you by ZEBRA shall be considered part of the SOFTWARE and/or FIRMWARE and subject to the terms of this PSFLA (unless this PSFLA is superseded by a further PSFLA accompanying such replacement or modified version of or upgrade to the SOFTWARE and/or FIRMWARE). In the event that ZEBRA offers a replacement or modified version of or any upgrade to the SOFTWARE and/or FIRMWARE, (a) your continued use of the SOFTWARE and/or FIRMWARE is conditioned on your acceptance of such replacement or modified version of or upgrade to the SOFTWARE and/or FIRMWARE and any accompanying superseding PSFLA and (b) in the case of the replacement or modified SOFTWARE and/or FIRMWARE, your use of all prior versions of the SOFTWARE and/or FIRMWARE is terminated.

4. **TERMINATION.** Without prejudice to any other rights, ZEBRA may terminate this PSFLA if you fail to comply with the terms and conditions of this PSFLA. ZEBRA may terminate this PSFLA by offering you a superseding PSFLA for the SOFTWARE and/or FIRMWARE or any replacement or modified version of or upgrade to the SOFTWARE and/or FIRMWARE and conditioning your continued use of the SOFTWARE and/or FIRMWARE or such replacement, modified or upgraded version on your acceptance of such superseding PSFLA. In addition, ZEBRA may terminate this PSFLA by notifying you that your continued use of the SOFTWARE and/or FIRMWARE is prohibited. In the event that ZEBRA terminates this PSFLA, you must immediately stop using the SOFTWARE and/or FIRMWARE and destroy all copies of the SOFTWARE and/or FIRMWARE and all of its component parts.
5. **COPYRIGHT.** All title and copyrights in and to the SOFTWARE and FIRMWARE, the accompanying printed materials, and any copies of the SOFTWARE and FIRMWARE, are owned by ZEBRA or its suppliers. All title and intellectual property rights in and to the content which may be accessed through use of the SOFTWARE and/or FIRMWARE is the property of the respective content owner and may be protected by applicable copyright or other intellectual property laws and treaties. This PSFLA grants you no rights to use such content. If this SOFTWARE and/or FIRMWARE contains documentation which is provided only in electronic form, you may print one copy of such electronic documentation. You may not copy the printed materials accompanying the SOFTWARE and/or FIRMWARE.
6. **U.S. GOVERNMENT RESTRICTED RIGHTS.** All SOFTWARE and/or FIRMWARE provided to the U.S. Government pursuant to solicitations issued on or after December 1, 1995 is provided with the commercial rights and restrictions described elsewhere herein. All SOFTWARE and/or FIRMWARE provided to the U.S. Government pursuant to solicitations issued prior to December 1, 1995 is provided with RESTRICTED RIGHTS as provided for in FAR, 48 CFR 52.227-14 (JUNE 1987) or DFAR, 48 CFR 252.227-7013 (OCT 1988), as applicable.
7. **EXPORT RESTRICTIONS.** You agree that you will not export or re-export the SOFTWARE and/or FIRMWARE, any part thereof, or any process or service that is the direct product of the SOFTWARE and/or FIRMWARE (the foregoing collectively referred to as the RESTRICTED COMPONENTS), to any country, person or entity subject to U.S. export restrictions. You specifically agree not to export or re-export any of the RESTRICTED COMPONENTS (i) to any country to which the U.S. has embargoed or restricted the export of goods or services, which currently include, but are not necessarily limited to Cuba, Iran, Iraq, Libya, North Korea, Sudan and Syria, or to any national of any such country, wherever located, who intends to transmit or transport the RESTRICTED COMPONENTS back to such country; (ii) to any person or entity who you know or have reason to know will utilize the RESTRICTED COMPONENTS in the design, development or production of nuclear, chemical or biological weapons; or (iii) to any person or entity who has been prohibited from participating in U.S. export transactions by any federal agency of the U.S. government. You warrant and represent that neither the U.S. Commerce Department, Bureau of Export Administration nor any other U.S. federal agency has suspended, revoked or denied your export privileges.

8. **DISCLAIMER OF WARRANTIES.** ZEBRA AND ITS SUPPLIERS PROVIDE THE SOFTWARE AND/OR FIRMWARE “AS IS” AND WITH ALL FAULTS, AND HEREBY DISCLAIM ALL OTHER WARRANTIES AND CONDITIONS, EITHER EXPRESS, IMPLIED OR STATUTORY, INCLUDING BUT NOT LIMITED TO ANY (IF ANY) IMPLIED WARRANTIES OR CONDITIONS OF MERCHANTABILITY, OF FITNESS FOR A PARTICULAR PURPOSE, OF LACK OF VIRUSES, AND OF LACK OF NEGLIGENCE OR LACK OF WORKMANLIKE EFFORT. ALSO, THERE IS NO WARRANTY OR CONDITION OF TITLE, OF QUIET ENJOYMENT, OR OF NONINFRINGEMENT. THE ENTIRE RISK ARISING OUT OF THE USE OR PERFORMANCE OF THE SOFTWARE AND FIRMWARE IS WITH YOU. ZEBRA DOES NOT WARRANT THAT THE OPERATION OF THE SOFTWARE OR FIRMWARE WILL BE UNINTERRUPTED OR ERROR FREE.
9. **EXCLUSION OF ALL DAMAGES.** TO THE MAXIMUM EXTENT PERMITTED BY APPLICABLE LAW, IN NO EVENT SHALL ZEBRA OR ITS SUPPLIERS BE LIABLE FOR ANY CONSEQUENTIAL, INCIDENTAL, DIRECT, INDIRECT, SPECIAL, PUNITIVE, OR OTHER DAMAGES WHATSOEVER (INCLUDING, WITHOUT LIMITATION, DAMAGES FOR ANY INJURY TO PERSON OR PROPERTY, DAMAGES FOR LOSS OF PROFITS, BUSINESS INTERRUPTION, LOSS OF BUSINESS INFORMATION, FOR LOSS OF PRIVACY FOR FAILURE TO MEET ANY DUTY INCLUDING OF GOOD FAITH OR OF REASONABLE CARE, FOR NEGLIGENCE, AND FOR ANY PECUNIARY OR OTHER LOSS WHATSOEVER) ARISING OUT OF OR IN ANY WAY RELATED TO THE USE OF OR INABILITY TO USE THE SOFTWARE OR FIRMWARE, WHETHER BASED ON CONTRACT, TORT, NEGLIGENCE, STRICT LIABILITY OR OTHERWISE, EVEN IF ZEBRA OR ANY SUPPLIER HAS BEEN ADVISED OF THE POSSIBILITY OF SUCH DAMAGES. THIS EXCLUSION OF DAMAGES SHALL BE EFFECTIVE EVEN IF ANY REMEDY FAILS OF ITS ESSENTIAL PURPOSE.
10. **LIMITATIONS AND RELEASE OF LIABILITY.**
  - To the extent that the SOFTWARE and/or FIRMWARE covered by this PSFLA includes emulation libraries, emulation libraries are offered “as is”. ZEBRA does not provide any warranty associated with the emulation libraries.
  - The emulation library does not work 100% correctly or cover 100% of the functionality of the printer language being emulated. Modifications may be required for each target application. If such modification is necessary, prior to making any such modification, you are required to contact ZEBRA to obtain express written consent to make such modification.
  - If the emulation library is sold separately by an authorized party other than ZEBRA (RESELLER—A party other than ZEBRA which is authorized by ZEBRA to distribute the SOFTWARE and/or FIRMWARE with its application so long as the SOFTWARE and/or FIRMWARE is used with a ZEBRA printer) or is sold bundled with a printer to an end-user by a RESELLER, and if claims are made by the RESELLER that the emulation library performs as a 100% emulation solution, ZEBRA is not responsible if the emulation library does not work as advertised by the RESELLER. Furthermore, ZEBRA is not liable for any damages directly or indirectly relating to such emulation library which is sold separately by the RESELLER or which is sold bundled with a printer to an end-user by the RESELLER.
  - The SOFTWARE and FIRMWARE was provided to you at no additional charge and ZEBRA has included in this PSFLA terms that disclaim all warranties and liability for the SOFTWARE and FIRMWARE. To the full extent allowed by law, YOU HEREBY RELEASE ZEBRA AND ITS SUPPLIERS FROM ANY AND ALL LIABILITY

ARISING FROM OR RELATED TO ALL CLAIMS CONCERNING THE SOFTWARE AND/OR FIRMWARE OR ITS USE. If you do not wish to accept the SOFTWARE OR FIRMWARE under the terms of this PSFLA, do not use the PRINTER enclosed with or otherwise associated with this PSFLA.

**11. GOVERNING LAW.** If you acquired the SOFTWARE and/or FIRMWARE in the United States of America, the laws of the State of Illinois, U.S.A. will apply to this contract. If you acquired this SOFTWARE and/or FIRMWARE outside of the United States of America, then local law may apply. If any provision of this PSFLA is held invalid, the remainder of this PSFLA shall continue in full force and effect.

**12. QUESTIONS.** Should you have any questions, or if you desire to contact ZEBRA for any reason, please contact the ZEBRA subsidiary serving your country, or write:

Zebra Technologies Corporation  
333 Corporate Woods Parkway  
Vernon Hills, IL 60061



Notes • \_\_\_\_\_  
\_\_\_\_\_  
\_\_\_\_\_  
\_\_\_\_\_  
\_\_\_\_\_  
\_\_\_\_\_  
\_\_\_\_\_  
\_\_\_\_\_  
\_\_\_\_\_  
\_\_\_\_\_

---

# Index



## A

- adhesive test for ribbon coating, 17
- adjustments
  - LCD, 58
  - left position, 55
  - lower media sensor, 38
  - media sensors, 37
  - print darkness, 44
  - print speed, 44
  - printhead toggle pressure, 39
  - tear-off position, 45
  - upper media sensor, 37
- alert setting, 47
- applicator port setting, 57
- authentication type, 61
- auto-calibration, 35

## B

- backfeed setting, 55
- bar codes
  - list available codes, 47
  - types of codes, 143
- baud setting, 51
- before you begin setup, 8
- bitmap scaling factor, 58
- black mark media
  - setting sensor type, 46

## C

- cable requirements, 13
- calibration
  - media and ribbon sensor, 50
  - methods, 35
  - RFID tag from front panel, 63
  - RFID tag using ZPL (^HR), 78
  - setting for head close, 54
  - setting for media power up, 54
- Canadian DOC compliance, 152
- CANCEL self test, 135
- characteristics of transponders, 68
- checklist
  - before you begin, 8
  - troubleshooting, 126
- Class 0 and 0+ transponder characteristics, 68
- Class 1 transponder characteristics, 68
- ❖❖❖❖ ❖❖❖❖ ❖❖❖❖ message, 128
- cleaning
  - exterior of printer, 116
  - interior, 117
  - printhead and platen roller, 117
  - recommended schedule, 116
  - sensors, 119
  - snap plate, 121
- communication interfaces
  - overview and location, 12
  - types of connections, 99

communications diagnostics test  
 sample printout, 139  
 selecting, 52

communications problems, 132

CompactFlash card  
 format, 48  
 installation, 112

components, 6

configuration  
 enter setup mode, 42  
 exit setup mode, 42

configuration label  
 print during CANCEL self test, 135  
 printing after loading printer, 32  
 printing using List Setup command, 48

connect printer to power source, 11

contact information, x

continuous media  
 described, 14  
 setting media type, 45

control prefix setting, 52

creases on labels, 131

create ribbon leader, 27

creating basic label formats, 69

customer support, x

## D

darkness setting, 44

data bits setting, 51

data cable requirements, 13

data connections  
 RS-232, 104  
 RS-422/RS-485, 106

data ports, 99

data source  
 communication interface location, 12  
 communication interfaces, 99  
 provide connections, 10

date setting, 59

DB-9 to DB-25 connection, 105

default gateway, 61

default password, 43

define EPC data structure (^RB), 81

delimiter character setting, 53

diagnostics  
 printer self tests, 134  
 RFID test, 62

direct connection to a computer, 104

direct thermal mode  
 media scratch test, 16  
 setting, 46

disable password protection, 43

display language selection, 59

display RFID tag data, 64

dpi format conversion, 58

## E

Early Warning setting, 47

electrical noise, 13

electrical specifications, 144

Electronic Product Code (EPC)  
 define EPC data structure (^RB), 81  
 EPC structure in RFID labels, 67  
 overview, 67

enable RFID motion (^RM), 85

encryption settings, 61

enter setup mode, 42

environmental specifications, 144

error messages, 127

ESSID setting, 61

exit setup mode, 42

exterior cleaning, 116

## F

fanfold media, 15

fanfold media loading, 24

FCC compliance, 151

FCC radiation exposure limits, 152

features, 142

FEED and PAUSE self test, 139

FEED self test, 138

Flash memory, 49

fonts  
 listing, 47  
 using CompactFlash card, 112  
 using PCMCIA memory card, 110

format convert setting, 58

format list, 48

format memory card, 48

format prefix setting, 53

front panel  
 buttons, 4  
 enter setup mode, 42  
 exit setup mode, 42  
 illustration, 3  
 LCD error messages, 127  
 LCD parameters, 44  
 lights, 5

fuse replacement, 122



**G**

gleaning, 60  
gray lines on labels, 130

**H**

★❖❖❖ ❖❖❖❖ message, 129  
★❖❖❖ ❖❖❖❖❖❖❖❖ ❖❖❖❖ message, 127  
★❖❖❖ ❖❖❖❖ message, 127  
★❖❖❖ ❖❖❖❖ ❖❖❖❖ message, 128  
host handshake setting, 51  
host verification command (^HV), 80

**I**

idle display setting, 59  
image not sharp, 130  
images list, 48  
initialize Flash memory, 49  
inspect the printer, 9  
interior cleaning, 117  
international safety organization marks, 11  
IP settings  
    default gateway, 61  
    IP address, 60  
    protocol, 60  
    subnet mask, 60  
ISO18000 transponder characteristics, 68

**L**

label formats for RFID, 69  
label length maximum setting, 46  
label specifications by model, 148  
label top  
    printer cannot detect, 133  
    setting, 55  
label-available sensor  
    location, 119  
    when to clean, 116  
labels did not print, 132  
labels per roll setting, 47  
language selection, 59  
LCD messages  
    adjust LCD settings, 58  
    error messages, 127  
    language selection, 59  
    setup mode, 44  
liability, 152  
light or no printing, 130  
lights on front panel, 5

list settings  
    all settings, 48  
    bar codes, 47  
    fonts, 47  
    formats, 48  
    images, 48  
    setup, 48  
load the printer  
    load fanfold media, 24  
    load roll media, 21  
    ribbon, 26  
long calibration, 35  
lower media sensor adjustment, 38

**M**

MAC address, 61  
mark LED setting, 58  
Mark Med S. setting, 58  
maximum label length setting, 46  
media  
    continuous roll media, 14  
    fanfold, 15  
    label specifications by model, 148  
    load fanfold media, 24  
    load roll media, 21  
    media LED setting, 58  
    media low warning, 47  
    non-continuous roll media, 14  
    RFID “smart” labels, 15  
    setting labels per roll, 47  
    setting media type, 45  
    types of media, 14  
media and ribbon sensor calibration  
    procedure, 50  
media path cleaning, 116  
media power up setting, 54  
Media S. setting, 58  
media scratch test, 16  
media sensor  
    adjustments, 37  
    location, 120  
    print media sensor profile, 49  
    sensor sensitivity calibration, 36  
memory card installation  
    CompactFlash card, 112  
    PCMCIA memory card, 110  
modem connection, 105  
motion in RFID label, 85

**N**

network configuration label  
 printing as baseline, 34  
 network ID setting, 52  
 non-continuous media  
 described, 14  
 setting media type, 45  
 number of retries for block (^RR), 86

**O**

operating conditions, 10  
 \*\*\* \*♦ \*◆\*\*\* message, 129

**P**

☆☆☆\* \*\*\* message, 127

parallel port  
 location, 12  
 pin configuration, 100  
 setting parallel communications, 50  
 settings, 100  
 parity setting, 51  
 passwords  
 default, 43  
 disable, 43  
 entering, 43  
 RFID tag password, 94  
 PAUSE self test, 137  
 PCMCIA card  
 format, 48  
 installing memory card, 110  
 pin configuration  
 parallel port, 100  
 serial port, 103  
 platen roller  
 cleaning, 117  
 when to clean, 116  
 ports, 99  
 power cord specifications, 11  
 power source, 11  
 Power-On Self Test (POST), 134  
 print configuration label  
 CANCEL self test, 135  
 List Setup command, 48  
 when printer is loaded, 32  
 print darkness setting, 44  
 printer components, 6  
 printer diagnostics, 134  
 printer operation, 19  
 printer self tests, 134

printer settings  
 applicator port, 57  
 backfeed, 55  
 baud, 51  
 configuration label as baseline, 32  
 control prefix, 52  
 data bits, 51  
 date, 59  
 delimiter character, 53  
 Early Warning, 47  
 format convert, 58  
 format prefix, 53  
 head resistor, 56  
 head test count, 56  
 host handshake, 51  
 idle display, 59  
 IP settings, 60  
 label top, 55  
 labels per roll, 47  
 language, 59  
 LCD, 58  
 left position, 55  
 maximum label length, 46  
 media type, 45  
 network configuration label as baseline, 34  
 network ID, 52  
 parallel communications, 50  
 parity, 51  
 passwords, 43  
 print darkness, 44  
 print method, 46  
 print server settings, 60  
 print speed, 44  
 print width, 46  
 protocol, 51  
 resynch mode, 58  
 RFID settings, 62  
 RFID tag type, 63  
 saving, 42  
 sensor type, 45  
 serial communications, 50  
 setting through front panel, 42  
 start print signal, 57  
 time, 59  
 verifier port, 56  
 ZPL mode, 53  
 printer setup checklist, 8



## RTC (Real-time clock) setting

- date, 59
- idle display, 59
- time, 59

**S**

## schedule for cleaning, 116

## scratch test

- media type, 16
- ribbon coated side, 17

## SCTIN-64 standard programming example, 82

## select a printer site, 10

## self tests

- CANCEL, 135
- FEED, 138
- FEED and PAUSE, 139
- how to perform additional tests, 134
- PAUSE, 137
- Power-On Self Test (POST), 134

## Sensor Profile calibration

- description, 36
- procedure, 49

## sensors

- cleaning, 119
- label-available sensor location, 119
- lower media sensor adjustment, 38
- ribbon sensor location, 119
- setting sensor type, 45
- transmissive (media) sensor adjustment, 37
- transmissive (media) sensor location, 120
- upper media sensor adjustment, 37

## serial port

- location, 12
- pin configuration, 103
- setting serial communications, 50
- settings, 102

## set RFID tag password (^RZ), 94

## setup checklist, 8

## setup mode

- enter setup mode, 42
- exit setup mode, 42
- LCD messages, 44

## shipping

- report damage, 9
- reship the printer, 9

## short calibration, 35

## site requirements, 10

## “smart” labels, 15

## snap plate

- cleaning, 121
- when to clean, 116

## spacing requirements, 10

## specifications

- by model number, 145
- electrical, 144
- environmental, 144
- general, 144
- power cord, 11
- ribbon, 147

## specify number of retries for block (^RR), 86

## specify RFID tag type, 63

## standard data ports, 99

## standard features, 142

## start print signal setting, 57

## store the printer, 9

## subnet mask, 60

## support, x

## surface for the printer, 10

**T**

## take label setting, 58

## Tear-Off Mode

- tear-off position adjustment, 45

## Tear-Off mode

- tear-off bar cleaning, 116

## temperature requirements, 10

## thermal transfer mode

- load ribbon, 26
- media scratch test, 16
- setting, 46

## time setting, 59

## toggle pressure adjustment, 39

## top of label

- printer cannot detect, 133
- setting, 55

## transmissive (media) sensor

- adjustment, 37
- location, 120
- when to clean, 116

## transponders

- calibrate from front panel, 63
- calibration using ZPL (^HR), 78
- characteristics of different types, 68
- placement in labels, 66
- selecting type, 68
- setting tag type, 68
- when to calibrate, 68

troubleshooting  
  checklist, 126  
  communications problems, 132  
  LCD error messages, 127  
  print quality problems, 130  
  printer diagnostics, 134  
  wrinkled ribbon, 131

types of media  
  continuous roll media, 14  
  fanfold media, 15  
  non-continuous roll media, 14  
  RFID “smart” labels, 15

**U**

unpack the printer, 9  
upper media sensor adjustment, 37  
USB 2.0 port  
  location, 12  
  settings, 107

**V**

verifier port setting, 56  
verify RFID write operation (^WV), 97  
vertical lines on labels, 131

**W**

web media, 14  
  setting sensor type, 45  
Web S. setting, 58  
Wireless Print Server settings  
  authentication type, 61  
  default gateway, 61  
  encryption, 61  
  ESSID, 61  
  IP address, 60  
  IP protocol, 60  
  MAC address, 61  
  reset network, 61  
  subnet mask, 60  
wrinkled ribbon, 131  
write power  
  change through front panel, 63  
  change using ZPL, 93  
write RFID format (^RF), 83  
write RFID tag (^WT), 95

**X**

XML-enabled printing, 67

**Z**

Zebra Programming Language (ZPL II)  
  features, 142  
  RFID label formats, 69  
  RFID ZPL commands, 77  
  ZPL mode setting, 53  
Zebra support, x







**Zebra Technologies Corporation**

333 Corporate Woods Parkway  
Vernon Hills, Illinois 60061.3109 U.S.A.  
Telephone: +1 847.634.6700  
Facsimile: +1 847.913.8766

**Zebra Technologies Europe Limited**

Zebra House  
The Valley Centre, Gordon Road  
High Wycombe  
Buckinghamshire HP13 6EQ, UK  
Telephone: +44 (0) 1494 472872  
Facsimile: +44 (0) 1494 450103

Customer Order # 23063L-003  
Manufacturer Part # 23063L-003 Rev. 2