



Engineering and Testing for EMC and Safety Compliance

**CLASS II PERMISSIVE CHANGE REPORT
FCC PART 15.247 & INDUSTRY CANADA RSS-210**

Test Lab: Rhein Tech Laboratories, Inc. Phone: 703-689-0368 360 Herndon Parkway Fax: 703-689-2056 Suite 1400 Web: www.rheintech.com Herndon, VA 20170 E-Mail: ATCBINFO@rheintech.com		Applicant: Zebra Technologies Corp. Phone: 847-793-5719 Contact: Charles Darrow Fax: 847-913-8766 333 Corporate Woods Pkwy Vernon Hills, IL 60061 E-Mail: cderrow@zebra.com	
FCC ID / IC ID:	I28MD-ZLAN11B / 3798A-ZLAN11B	TEST REPORT DATE:	February 10, 2006
PLATFORM:	N/A	RTL WORK ORDER #:	2006011B
MODEL NAME/MODEL #:	ZLAN11B / AT17192-1	RTL QUOTE #:	QRTL06-132
Standards and Procedures:	ANSI 63.4 and FCC 97-114 (DSSS)		
FCC Classification:	DTS		
FCC Rule Part:	Part 15.247: Operation within the bands 920-928 MHz, 2400-2483.5 MHz and 5725-5850 MHz Direct Sequence System		
Industry Canada Standard:	RSS-210: Low Power License-Exempt Radio Communication Devices (All Frequency Bands)		
Digital Interface Information	Digital Interface was found to be compliant		
Frequency Range (MHz)	Output Power*(W)	Frequency Tolerance	Emission Designator
2412-2462	0.045	N/A	N/A

* output power is maximum peak conducted

I, the undersigned, hereby declare that the equipment tested and referenced in this report conforms to the identified standard(s) as described in this test report. No modifications were made to the equipment during testing in order to achieve compliance with these standards.

Furthermore, there was no deviation from, additions to, or exclusions from the applicable parts or FCC Part 2, FCC Part 15, Industry Canada RSS-210, ANSI 63.4, and FCC 97-114 (DSSS).

Signature: 

Date: February 10, 2006

Typed/Printed Name: Desmond A. Fraser

Position: President

Table of Contents

1	General Information	4
1.1	Scope	4
1.2	Test Facility	4
1.3	Related Submittal(s)/Grant(s)	4
1.4	Modifications	4
2	Test Information	5
2.1	Test Justification	5
2.2	Exercising the EUT	5
2.3	Test Result Summary	5
2.4	Test System Details	6
2.5	Configuration of Tested System	7
3	Peak Output Power - FCC §15.247(b)(1); IC RSS-210 §6.2.2(o)(b)	8
3.1	Power Output Test Procedure	8
3.2	Power Output Test Data	8
3.3	Power Output Test Equipment	8
4	Compliance with the Restricted Band Edge - FCC §15.247(c), §15.205; IC RSS-210 §6.3	9
4.1	Band Edge Test Procedure	9
4.2	Restricted Band Edge Plots	9
4.3	Band Edge Test Equipment	13
5	Radiated Emissions Radiated Harmonics/Spurious Noise – FCC §15.247; IC RSS-210 §6.2.2(o)(e1); §6.3	14
5.1	Radiated Emissions Test Procedure for Harmonics/Spurious Noise	14
5.2	Radiated Emissions Harmonics/Spurious Test Data	14
5.3	Radiated Spurious Emissions Test Equipment	16
6	Conclusion	17

Figure Index

Figure 2-1:	Worst Case Configuration of System under Test.....	7
-------------	--	---

Table Index

Table 2-1:	Test Result Summary of FCC Rules and Regulations	5
Table 2-2:	Equipment under Test (EUT)	6
Table 2-3:	Additional Equipment Used for Testing	6
Table 3-1:	Power Output Test Data	8
Table 3-2:	Power Output Test Equipment	8
Table 4-1:	Band Edge Test Equipment	13
Table 5-1:	Radiated Emissions Harmonics/Spurious (Channel 1/2412 MHz) CQ17718-G1 Antenna.....	14
Table 5-2:	Radiated Emissions Harmonics/Spurious (Channel 6/2437 MHz) CQ17718-G1 Antenna.....	14
Table 5-3:	Radiated Emissions Harmonics/Spurious (Channel 11/2462 MHz) CQ17718-G1 Antenna.....	14
Table 5-4:	Radiated Emissions Harmonics/Spurious (Channel 1/2412 MHz) CQ17718-G2 Antenna.....	15
Table 5-5:	Radiated Emissions Harmonics/Spurious (Channel 6/2437 MHz) CQ17718-G1 Antenna.....	15
Table 5-6:	Radiated Emissions Harmonics/Spurious (Channel 11/2462 MHz) CQ17718-G1 Antenna.....	15
Table 5-7:	Radiated Spurious Emissions Test Equipment	16

Plot Index

Plot 4-1:	Lower Band Edge: Delta Measurement.....	10
Plot 4-2:	Upper Band Edge: Delta Measurement.....	12

Appendix Index

Appendix A:	RF Exposure; IC RSS-210 §14.....	18
Appendix B:	Antenna Specifications	19
Appendix C:	Change Description Letter	20
Appendix D:	Agency Authorization Letter.....	21
Appendix E:	IC Agency and Listing Requirements Letters.....	22
Appendix F:	Test Photographs	23
Appendix G:	External Photographs	27

Photograph Index

Photograph 1:	Radiated Emissions - Front View of CQ17718-G1 Antenna Testing	23
Photograph 2:	Radiated Emissions - Rear View of CQ17718-G1 Antenna Testing.....	24
Photograph 3:	Radiated Emissions - Front View of CQ17718-G2 Antenna Testing	25
Photograph 4:	Radiated Emissions - Rear View of CQ17718-G2 Antenna Testing.....	26
Photograph 5:	Top of Antenna CQ17718-G1	27
Photograph 6:	Bottom of Antenna CQ17718-G1	28
Photograph 7:	Top of Antenna CQ17718-G2	29
Photograph 8:	Bottom of Antenna CQ17718-G2	30
Photograph 9:	Separation Distance Between CQ17718-G1 Antenna and Body	31

1 General Information

1.1 Scope

FCC Rules Part 15.247: Frequency Hopping, Direct Spread Spectrum and Hybrid Systems that are in operation within the bands of 902-928 MHz, 2400-2483.5 MHz, and 5725-5850 MHz.

IC RSS-210 Section 6.2.2(o): Frequency Hopping, Direct Spread Spectrum, and Hybrid Systems that are in operation within the bands of 902-928 MHz, 2400-2483.5 MHz, and 5725-5850 MHz.

1.2 Test Facility

The open area test site and conducted measurement facility used to collect the radiated data is located at 360 Herndon Parkway, Suite 1400, Herndon, Virginia 20170. This site has been fully described in a report and approved by the Federal Communications Commission to perform AC line conducted and radiated emissions testing (ANSI C63.4 2003).

1.3 Related Submittal(s)/Grant(s)

This is a request for a Class II Permissive Change per FCC 2.1043(b)(2) for the previously certified Zebra Technologies Corp., Model Number: AT17192-1, FCC ID: I28MD-ZLAN11B. The change is the addition of two antennas, model CQ17718-G1 and model CQ17718-G2, to be used in the Cameo host.

1.4 Modifications

No modifications were implemented to meet testing criteria.

2 Test Information

2.1 Test Justification

The EUT was tested in all three orthogonal planes in order to determine worst case emissions. Channel 1 at 2412 MHz, Channel 6 at 2437 MHz, and Channel 11 at 2462 MHz were tested and investigated from 9 kHz to 24 GHz. Data for all three channels is presented in this report.

The worst case data presented in this report represents the highest data rate at 11 MBPS. Data rates of 5.5 MBPS, 2 MBPS and 1 MBPS were investigated and found to be in compliance. The change in envelope did not cause the EUT to be non-compliant in any of the aforementioned modes.

2.2 Exercising the EUT

The EUT was provided with software to continuously transmit during testing. The carrier was also checked to verify that the information was being transmitted. There were no deviations from the test standard(s) and/or methods.

2.3 Test Result Summary

Table 2-1: Test Result Summary of FCC Rules and Regulations

STANDARD	TEST	PASS/FAIL OR N/A
FCC 15.205	Compliance with the Restricted Band Edge	Pass
FCC 15.209	Radiated Emissions	Pass
FCC 15.247(b)	Power Output	Pass

2.4 Test System Details

The test sample was received on February 6, 2006. The FCC Identifiers for all equipment, and descriptions of all cables used in the tested system, are shown in the following table.

Table 2-2: Equipment under Test (EUT)

Part	Manufacturer	Model #	Serial Number	FCC ID	Cable Description	RTL Bar Code
Wireless LAN Adapter (EUT)	DPAC	AT17192-1	N/A	I28MD-ZLAN11B	N/A	16997
Antenna	Zebra Technologies	CQ17718-G1	10605041B	N/A	14 cm shielded with ferrite	17019
Antenna	Zebra Technologies	CQ17718-G2	105520EWW	N/A	14 cm shielded with ferrite	16995

Table 2-3: Additional Equipment Used for Testing

Part	Manufacturer	Model #	Serial Number	FCC ID	Cable Description	RTL Bar Code
Wireless Printer	Zebra Technologies	QL-420	XXRD06-04-5037	N/A	N/A	17017
7.4 VDC Battery	Zebra Technologies	CT17497-1	33305HCG	N/A	N/A	17018
7.4 VDC Battery	Zebra Technologies	AT16293-1	N/A	N/A	N/A	17025
Battery Charger	Zebra Technologies	L172	N/A	N/A	2 m shielded	16692

2.5 Configuration of Tested System

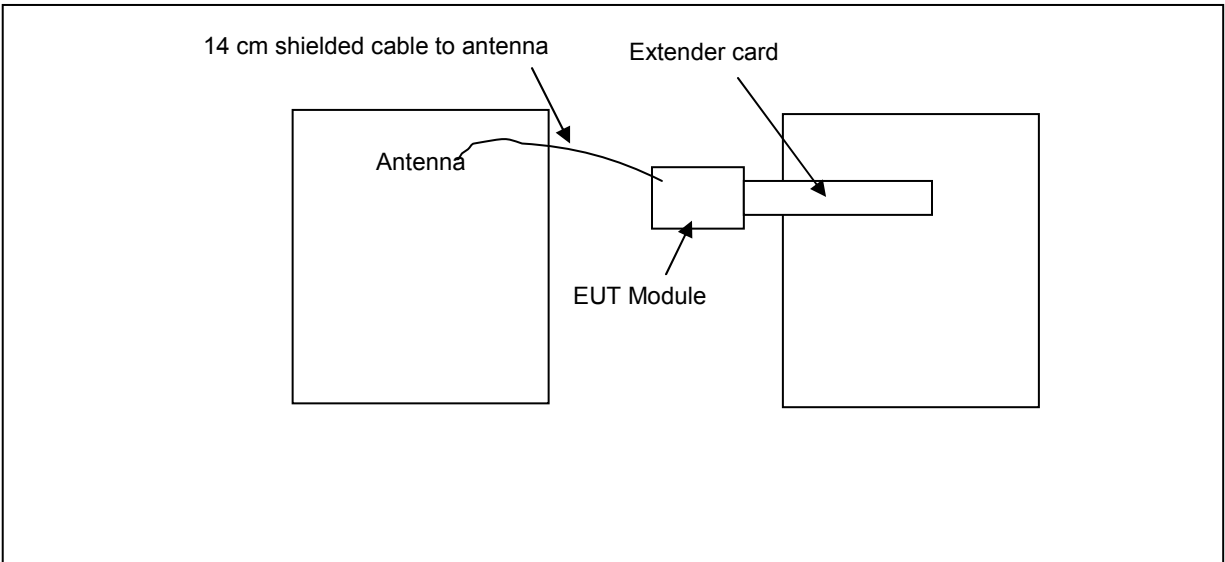

Figure 2-1: Worst Case Configuration of System under Test

3 Peak Output Power - FCC §15.247(b)(1); IC RSS-210 §6.2.2(o)(b)

3.1 Power Output Test Procedure

The conducted output power of the EUT was measured using an Agilent 4416A EPM-P Series Power Meter with an E9323A Peak and Average Power Sensor.

3.2 Power Output Test Data

Table 3-1: Power Output Test Data

CHANNEL	PEAK POWER CONDUCTED OUTPUT (dBm)
1	16.5
6	15.5
11	15.6

*Measurement accuracy is +/-1.5 dB

TEST PERSONNEL:

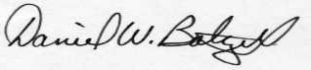
Daniel W. Baltzell Test Engineer	 Signature	February 6, 2006 Date Of Test
-------------------------------------	---	----------------------------------

3.3 Power Output Test Equipment

Table 3-2: Power Output Test Equipment

RTL Asset #	Manufacturer	Model	Part Type	Serial Number	Calibration Due Date
901356	Agilent Technologies	E9323A	Power Sensor	31764-264	9/21/06
901184	Agilent Technologies	E4416A	EPM-P Power Meter, single channel	GB41050573	9/21/06

4 Compliance with the Restricted Band Edge - FCC §15.247(c), §15.205; IC RSS-210 §6.3

4.1 Band Edge Test Procedure

Compliance with the band edges was performed using the FCC's "Radiated Measurement at a Band Edge" guidance document. The final data derived below were from radiated measurements only. The data shown in this report represents the worst case at 11 MBPS. Data rates of 5.5 MBPS, 2 MBPS, and 1 MBPS were investigated and found to be in compliance.

4.2 Restricted Band Edge Plots

Calculation of Lower Band Edge for Antenna CQ17718-G1

The level 89.9 dBuV/m is the worst case average field strength measurement, from which the delta measurement of 54.3 dB is subtracted (reference plot), which is equivalent to a level of 35.6 dB. This level has a margin of 18.4 dB under the limit of 54 dBuV/m.

Calculation: $89.9 \text{ dBuV/m} - 54.3 \text{ dB} - 54 \text{ dBuV/m} = -18.4 \text{ dB}$

Peak field strength of Channel 1 (1 MHz RBW/1 MHz VBW) = 93.6 dBuV/m
Average field strength of Channel 1 (1 MHz RBW/10 Hz VBW) = 89.9 dBuV/m

Delta measurement: 54.3 dB

Channel Number: 1
Frequency (MHz): 2412
Resolution Bandwidth (kHz): 300
Video Bandwidth (Hz): 10
Sweep Time (s): 50

Plot 4-1: Lower Band Edge: Delta Measurement

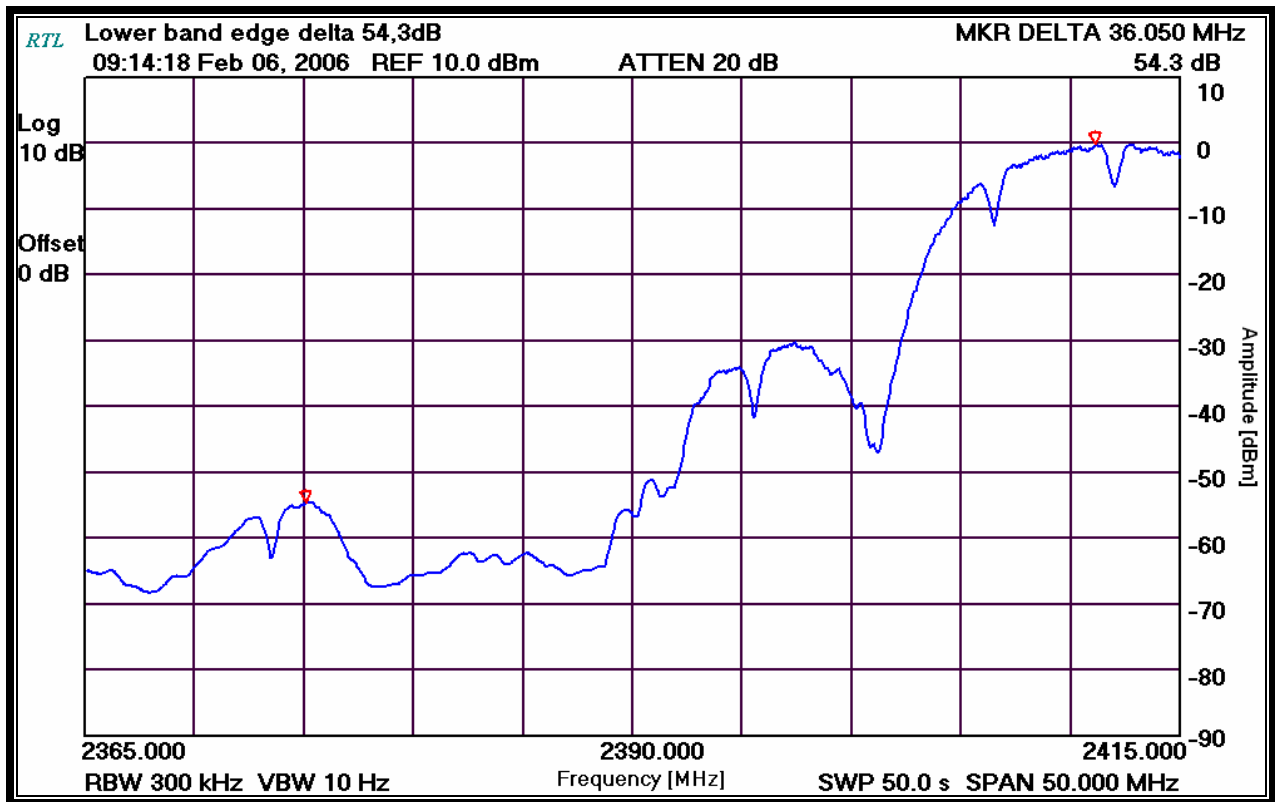

TEST PERSONNEL:

Daniel W. Baltzell
Test Engineer

Signature

February 6, 2006
Date Of Test

Calculation of Upper Band Edge

The level 90.6 dBuV/m is the worst case average field strength measurement, from which the delta measurement of 55.1 dB is subtracted (reference plots), which is equivalent to a level of 35.5 dB. This level has a margin of 18.5 dB below the limit of 54 dBuV/m.

Calculation: $90.6 \text{ dBuV/m} - 55.1 \text{ dB} - 54 \text{ dBuV/m} = -18.5 \text{ dB}$

Peak field strength of Channel 1 (1 MHz RBW/1 MHz VBW) = 94.4 dBuV/m
Average field strength of Channel 1 (1 MHz RBW/10 Hz VBW) = 90.6 dBuV/m

Delta measurement: 55.1 dB

Channel Number: 11
Frequency (MHz): 2462
Resolution Bandwidth (kHz): 300
Video Bandwidth (Hz): 10
Sweep Time (s): 50

Plot 4-2: Upper Band Edge: Delta Measurement

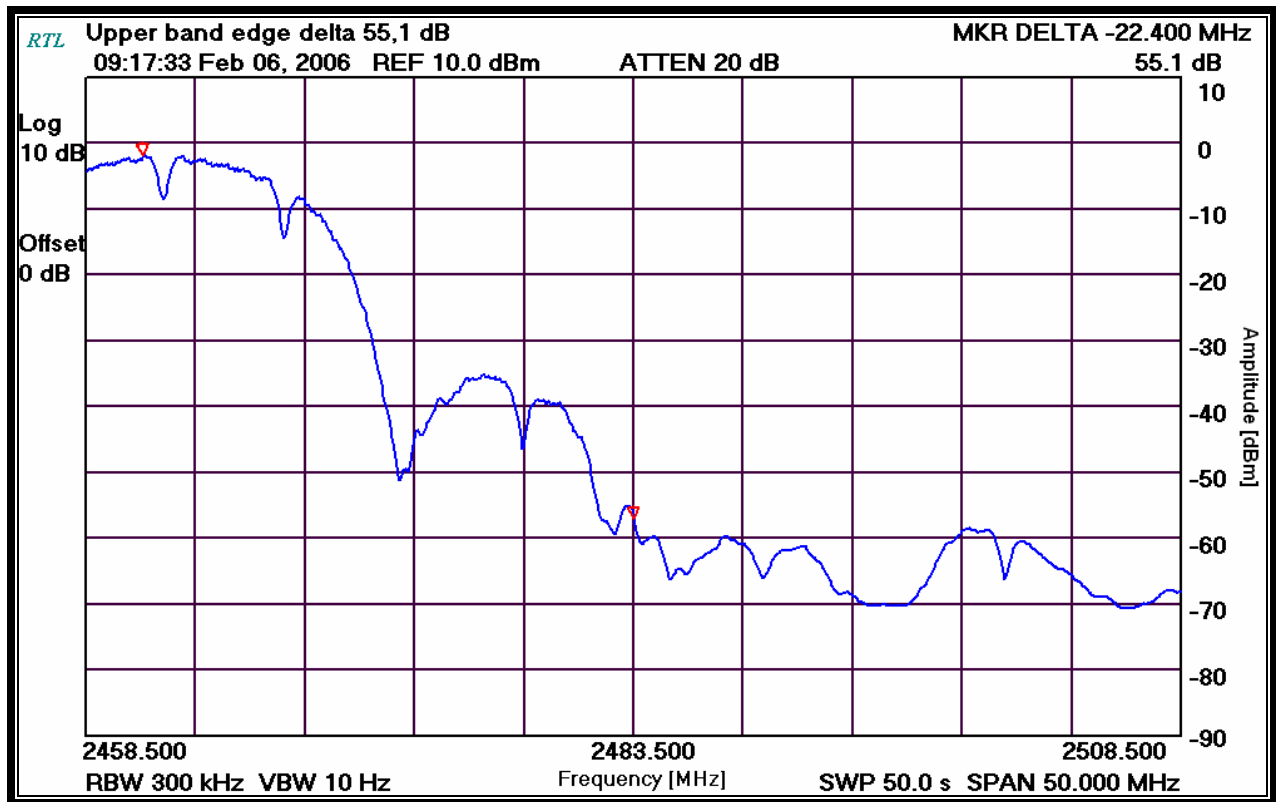

TEST PERSONNEL:

Daniel W. Baltzell
Test Engineer

Signature

February 6, 2006
Date Of Test

4.3 Band Edge Test Equipment

Table 4-1: Band Edge Test Equipment

RTL Asset #	Manufacturer	Model	Part Type	Serial Number	Calibration Due Date
900878	Rhein Tech Labs	AM3-1197-0005	3 meter Antenna Mast, Polarizing	Outdoor Range 1	Not Required
901242	Rhein Tech Labs	WRT-000-0003	Wood Rotating Table	N/A	Not Required
901424	IW Microwave Products	KPS-1503-2400-KPS	High Frequency RF Cables	240"	12/11/06
901425	IW Microwave Products	KPS-1503-360-KPS	High Frequency RF Cables	36"	12/11/06
900772	EMCO	3161-02	Horn Antenna	9804-1044	5/20/07
900932	Hewlett Packard	8449B OPT H02	Preamplifier (1 - 26.5 GHz)	3008A00505	5/20/06
901020	Hewlett Packard	8564E	Spectrum Analyzer (30 Hz - 40 GHz)	3943A01719	9/14/06
900931	Hewlett Packard	8566B	Spectrum Analyzer (100 Hz - 22 GHz)	3138A07771	4/5/06

5 Radiated Emissions Radiated Harmonics/Spurious Noise – FCC §15.247; IC RSS-210 §6.2.2(o)(e1); §6.3

5.1 Radiated Emissions Test Procedure for Harmonics/Spurious Noise

Radiated Spurious Emissions apply to harmonics and spurious emissions that fall in the restricted bands when the EUT is configured in the transmit mode. The restricted bands are listed in Part 15.205. The maximum permitted average field strength for the restricted band is listed in Part 15.209. The EUT was tested in three orthogonal planes from 10 kHz to the 10th harmonic of the fundamental. The data in this report represents the worst case modes.

5.2 Radiated Emissions Harmonics/Spurious Test Data

Table 5-1: Radiated Emissions Harmonics/Spurious (Channel 1/2412 MHz) CQ17718-G1 Antenna

Emission Frequency (MHz)	Peak Test Detector (dBuV)	Average Test Detector (dBuV)	Site Correction Factor (dB/m)	Emission Level (dBuV/m)	Limit (dBuV/m)	Margin (dB)
2375.500	30.8	19.5	25.6	45.1	54.0	-8.9
2449.000	31.0	20.0	25.8	45.8	69.9	-24.1
4824.000	48.0	39.3	10.3	49.6	54.0	-4.4
7236.000	44.2	31.2	10.2	41.4	69.9	-28.5
9648.000	45.7	32.8	12.6	45.4	69.9	-24.5
12060.000	45.5	34.2	15.9	50.1	54.0	-3.9

Fundamental Field Strength (1 MHz / Resolution/Video Bandwidth; 89.9 dBuV/m)

Table 5-2: Radiated Emissions Harmonics/Spurious (Channel 6/2437 MHz) CQ17718-G1 Antenna

Emission Frequency (MHz)	Peak Test Detector (dBuV)	Average Test Detector (dBuV)	Site Correction Factor (dB/m)	Emission Level (dBuV/m)	Limit (dBuV/m)	Margin (dB)
2399.900	31.0	19.5	25.8	45.3	70.0	-24.7
2473.870	29.8	19.8	25.9	45.7	70.0	-24.3
4874.000	48.7	40.3	9.8	50.1	54.0	-3.9
7311.000	45.5	32.0	9.7	41.7	54.0	-12.3
9748.000	43.5	33.2	12.6	45.8	70.0	-24.2
12185.000	44.5	31.7	14.6	46.3	54.0	-7.7

Fundamental Field Strength (1 MHz / Resolution/Video Bandwidth; 90 dBuV/m)

Table 5-3: Radiated Emissions Harmonics/Spurious (Channel 11/2462 MHz) CQ17718-G1 Antenna

Emission Frequency (MHz)	Peak Test Detector (dBuV)	Average Test Detector (dBuV)	Site Correction Factor (dB/m)	Emission Level (dBuV/m)	Limit (dBuV/m)	Margin (dB)
2425.000	27.5	18.0	25.6	43.6	70.6	-27.0
2499.100	29.8	20.0	25.7	45.7	54.0	-8.3
4924.000	46.0	38.8	10.1	48.9	54.0	-5.1
7386.000	45.2	31.7	11.3	43.0	70.6	-27.6
9848.000	46.7	33.0	13.4	46.4	70.6	-24.2
12310.000	44.5	32.0	13.9	45.9	70.6	-24.7

Fundamental Field Strength (1MHz / Resolution/Video Bandwidth; 90.6 dBuV/m)

Table 5-4: Radiated Emissions Harmonics/Spurious (Channel 1/2412 MHz) CQ17718-G2 Antenna

Emission Frequency (MHz)	Peak Test Detector (dBuV)	Average Test Detector (dBuV)	Site Correction Factor (dB/m)	Emission Level (dBuV/m)	Limit (dBuV/m)	Margin (dB)
2375.500	31.0	19.5	25.6	45.1	54.0	-8.9
2449.000	31.3	20.2	25.8	46.0	71.4	-25.4
4824.000	47.0	37.2	10.3	47.5	54.0	-6.5
7236.000	43.3	31.2	10.2	41.4	71.4	-30.0
9648.000	46.7	33.5	12.6	46.1	71.4	-25.3
12060.000	44.0	30.5	15.9	46.4	54.0	-7.6

Fundamental Field Strength (1 MHz / Resolution/Video Bandwidth; 91.4 dBuV/m)

Table 5-5: Radiated Emissions Harmonics/Spurious (Channel 6/2437 MHz) CQ17718-G2 Antenna

Emission Frequency (MHz)	Peak Test Detector (dBuV)	Average Test Detector (dBuV)	Site Correction Factor (dB/m)	Emission Level (dBuV/m)	Limit (dBuV/m)	Margin (dB)
2399.900	30.8	19.5	25.8	45.3	72.4	-27.1
2473.870	31.3	20.0	25.9	45.9	72.4	-26.5
4874.000	37.7	37.5	9.8	47.3	54.0	-6.7
7311.000	44.7	31.8	9.7	41.5	54.0	-12.5
9748.000	44.3	32.2	12.6	44.8	72.4	-27.6
12185.000	41.8	31.7	14.6	46.3	54.0	-7.7

Fundamental Field Strength (1 MHz / Resolution/Video Bandwidth; 92.4 dBuV/m)

Table 5-6: Radiated Emissions Harmonics/Spurious (Channel 11/2462 MHz) CQ17718-G2 Antenna

Emission Frequency (MHz)	Peak Test Detector (dBuV)	Average Test Detector (dBuV)	Site Correction Factor (dB/m)	Emission Level (dBuV/m)	Limit (dBuV/m)	Margin (dB)
2425.000	2.8	19.2	25.6	44.8	72.4	-27.6
2499.100	31.2	20.0	25.7	45.7	54.0	-8.3
4924.000	47.1	36.8	10.1	46.9	54.0	-7.1
7386.000	44.3	31.7	11.3	43.0	72.4	-29.4
9848.000	43.5	33.2	13.4	46.6	72.4	-25.8
12310.000	44.8	32.2	13.9	46.1	72.4	-26.3

Fundamental Field Strength (1MHz / Resolution/Video Bandwidth; 92.4 dBuV/m)

TEST PERSONNEL:

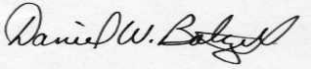
Daniel W. Baltzell Test Engineer	 Signature	February 9, 2007 Date Of Test
-------------------------------------	--	----------------------------------

5.3 Radiated Spurious Emissions Test Equipment

Table 5-7: Radiated Spurious Emissions Test Equipment

RTL Asset #	Manufacturer	Model	Part Type	Serial Number	Calibration Due Date
900878	Rhein Tech Labs	AM3-1197-0005	3 Meter Antenna Mast, Polarizing	Outdoor Range 1	Not Required
901242	Rhein Tech Labs	WRT-000-0003	Wood Rotating Table	N/A	Not Required
901424	IW Microwave Products	KPS-1503-2400-KPS	High Frequency RF Cables	240"	12/11/06
901425	IW Microwave Products	KPS-1503-360-KPS	High Frequency RF Cables	36"	12/11/06
900772	EMCO	3161-02	Horn Antenna (2 – 4 GHz)	9804-1044	5/20/07
900321	EMCO	3161-03	Horn Antennas (4-8,2 GHz)	9508-1020	5/20/07
900323	EMCO	3160-7	Horn Antennas (8,2-12,4 GHz)	9605-1054	5/20/07
900325	EMCO	3160-9	Horn Antennas (18 - 26.5 GHz)	9605-1051	5/20/07
900932	Hewlett Packard	8449B OPT H02	Preamplifier (1 - 26.5 GHz)	3008A00505	5/20/06
901020	Hewlett Packard	8564E	Portable Spectrum Analyzer (9 kHz - 40 GHz)	3943A01719	9/14/06

Rhein Tech Laboratories, Inc.
360 Herndon Parkway
Suite 1400
Herndon, VA 20170
<http://www.rheintech.com>

Client: Zebra Technologies
FCC: Part 15.247
IC: RSS-210
FCC ID: I28MD-ZLAN11B
Model: ZLAN11B

6 Conclusion

The data in this measurement report shows that the Zebra Technologies Corp. Model # AT17192-1, FCC ID: I28MD-ZLAN11B with antenna models CQ17718-G1 and CQ17718-G2, complies with all the applicable requirements of Parts 2 and 15 of the FCC Rules, Industry Canada RSS-210, ANSI 63.4 and FCC 97-114 (DSSS).