

**PRELIMINARY**



**Zebra®** RW 420  
Mobile Printer

# User Guide





# Contents

---

<b>Proprietary Statement</b> .....	<b>5</b>
<b>Introduction to the RW 420</b> .....	<b>9</b>
Unpacking and Inspection .....	9
Reporting Damage .....	9
<b>Getting Ready to Print</b> .....	<b>11</b>
Battery .....	11
Battery Safety .....	11
Installing the Battery .....	11
Charging the Battery .....	11
Model LI 72 Single Battery Charger .....	11
Model UCLI72-4 Quad Charger.....	12
Charger Safety.....	12
Loading the Media.....	14
Loading Media in the RW 420 Printer.....	14
Loading Media From An Internal Supply .....	15
Loading Media From An External Supply .....	16
Operator Controls.....	18
Control Panel .....	18
Verify the Printer Is Working.....	22
Printing a Configuration Label .....	22
<b>Connecting the Printer</b> .....	<b>23</b>
Cable Communications .....	23
Serial (RS232C).....	23
USB .....	24
Wireless Communications .....	25
Wireless Communications with Bluetooth® .....	25
Wireless Local Area Network Overview.....	27
Compact Flash (802.11b) Radio Module .....	28
Zebra 802.11b Radio Module .....	30
Setting Up the Software.....	32
<b>Card Reader Options</b> .....	<b>33</b>
Magnetic Stripe Reader.....	33
Smart Card Reader .....	35
<b>Using the Accessories</b> .....	<b>36</b>
Belt Clip.....	36
Adjustable Shoulder Strap.....	37
Cradle.....	38
Installing the Printer in the Cradle .....	38
Removing the Printer from the Cradle .....	40
<b>Preventive Maintenance</b> .....	<b>41</b>
Extending Battery Life .....	41
Cleaning Instructions.....	41
<b>Troubleshooting</b> .....	<b>43</b>
LCD Control Panel Indicators .....	43
Troubleshooting Topics .....	44

---

Troubleshooting Techniques.....	46
Printing a Configuration Label .....	46
Performing a Forced Shutdown.....	46
Communications Diagnostics.....	46
Calling Technical Support .....	47
<b>Specifications .....</b>	<b>51</b>
Printing Specifications .....	51
Memory/Communications Specifications.....	51
Communications Ports.....	52
USB .....	52
RS232.....	52
Media Specifications.....	54
Font/Bar Code Specifications .....	55
Physical/Environmental/Electrical Specifications .....	56
RW 420 Accessories .....	58
<b>Appendix A.....</b>	<b>57</b>
Interface Cables.....	57
RS232 Download Cable .....	57
USB Cable.....	57
More Interface Cables .....	58
<b>Appendix B-Media Supplies.....</b>	<b>59</b>
<b>Appendix C-Maintenance Supplies.....</b>	<b>59</b>
<b>Appendix D.....</b>	<b>60</b>
Product Support .....	60
Battery Disposal .....	61
Product Disposal .....	61
<b>Appendix E-Web Links .....</b>	<b>62</b>
<b>Index .....</b>	<b>64</b>
<b>Patent Numbers.....</b>	<b>65</b>

# Proprietary Statement

---

This manual contains proprietary information of Zebra Technologies Corporation. It is intended solely for the information and use of parties operating and maintaining the equipment described herein. Such proprietary information may not be used, reproduced, or disclosed to any other parties for any other purpose without the expressed written permission of Zebra Technologies Corporation.

## Product Improvements

Since continuous product improvement is a policy of Zebra Technologies Corporation, all specifications and signs are subject to change without notice.

## FCC Compliance Statement

Class B digital device. Tested to comply with FCC standards for home or office use.

**WARNING:** Exposure to Radio Frequency radiation. To conform to FCC RF exposure requirements this device shall be used in accordance with the operating conditions and instructions listed in this manual. Note that there are several radio options available with this printer. Additional regulatory information is contained in later sections devoted to each radio individually.

**NOTE:** This unit was tested with shielded cables on the peripheral devices. Shielded cables must be used with the unit to insure compliance.

Changes or modifications to this unit not expressly approved by Zebra Technologies Corporation could void the user's authority to operate this equipment.

## Canadian Compliance Statement

This Class B digital apparatus complies with Canadian ICES-003.

Cet appareil numérique de la classe B est conforme à la norme NMB-003 du Canada.

"IC:" before the equipment certification number signifies that the Industry Canada technical specifications were met. It does not guarantee that the certified product will operate to the user's satisfaction.

## Agency Approvals and Regulatory Information

- Design certified by CSA
- FCC part 15
- NOM/NYCE (Mexico)
- C-Tick (Australia)
- IP54 Certified
- Canadian STD RSS-210
- EN60950: 2000 Safety Standard
- EN55022:1998 Class B European Electromagnetic Radiation Standard

## Liability Disclaimer

Inasmuch as every effort has been made to supply accurate information in this manual, Zebra Technologies Corporation is not liable for any erroneous information or omissions. Zebra Technologies Corporation reserves the right to correct any such errors and disclaims liability resulting therefrom.

## No Liability for Consequential Damage

In no event shall Zebra Technologies Corporation or anyone else involved in the creation, production, or delivery of the accompanying product (including hardware and software) be liable for any damages whatsoever (including, without limitation, damages for loss of business profits, business interruption, loss of business information, or other pecuniary loss) arising out of the use of or the results of use of or inability to use such product, even if Zebra Technologies Corporation has been advised of the possibility of such damages. Because some states do not allow the exclusion of liability for consequential or incidental damages, the above limitation may not apply to you.

## Copyrights

The copyrights in this manual and the label print engine described therein are owned by Zebra Technologies Corporation. Unauthorized reproduction of this manual or the software in the label print engine may result in imprisonment of up to one year and fines of up to \$10,000 (17 U.S.C.506). Copyright violators may be subject to civil liability.

This product may contain ZPL®, ZPL II®, and ZebraLink™ programs; Element Energy Equalizer® Circuit; E3®; and AGFA fonts. Software © ZIH Corp. All rights reserved worldwide. ZebraLink and all product names and numbers are trademarks, and Zebra, the Zebra logo, ZPL, ZPL II, Element Energy Equalizer Circuit, and E3 Circuit are registered trademarks of ZIH Corp. All rights reserved worldwide.

Monotype®, Intellifont® and UFST® are trademarks of Monotype Imaging, Inc. registered in the United States Patent and Trademark Office and may be registered in certain jurisdictions.

continued

---

Andy™, CG Palacio™, CG Century Schoolbook™, CG Triumvirate™, CG Times™, Monotype Kai™, Monotype Mincho™ and Monotype Sung™ are trademarks of Monotype Imaging, Inc. and may be registered in some jurisdictions.

HY Gothic Hangul™ is a trademark of Hanyang Systems, Inc.

Angsana™ is a trademark of Unity Progress Company (UPC) Limited.

Andale®, Arial®, Book Antiqua®, Corsiva®, Gill Sans®, Sorts® and Times New Roman® are trademarks of The Monotype Corporation registered in the United States Patent and Trademark Office and may be registered in certain jurisdictions.

Century Gothic™, Bookman Old Style™ and Century Schoolbook™ are trademarks of The Monotype Corporation and may be registered in certain jurisdictions.

HGPGothicB is a trademark of the Ricoh company, Ltd. and may be registered in some jurisdictions.

Univers™ is a trademark of Heidelberger Druckmaschinen AG, which may be registered in certain jurisdictions, exclusively licensed through Linotype Library GmbH, a wholly owned subsidiary of Heidelberger Druckmaschinen AG.

Futura® is a trademark of Bauer Types SA registered in the United States Patent and Trademark Office and may be registered in some jurisdictions.

TrueType® is a trademark of Apple Computer, Inc. registered in the United States Patent and Trademark Office and may be registered in certain jurisdictions.

All other brand names, product names, or trademarks belong to their respective holders.

©2005 ZIH Corp.



**Figure 1: RW 420 Overview**

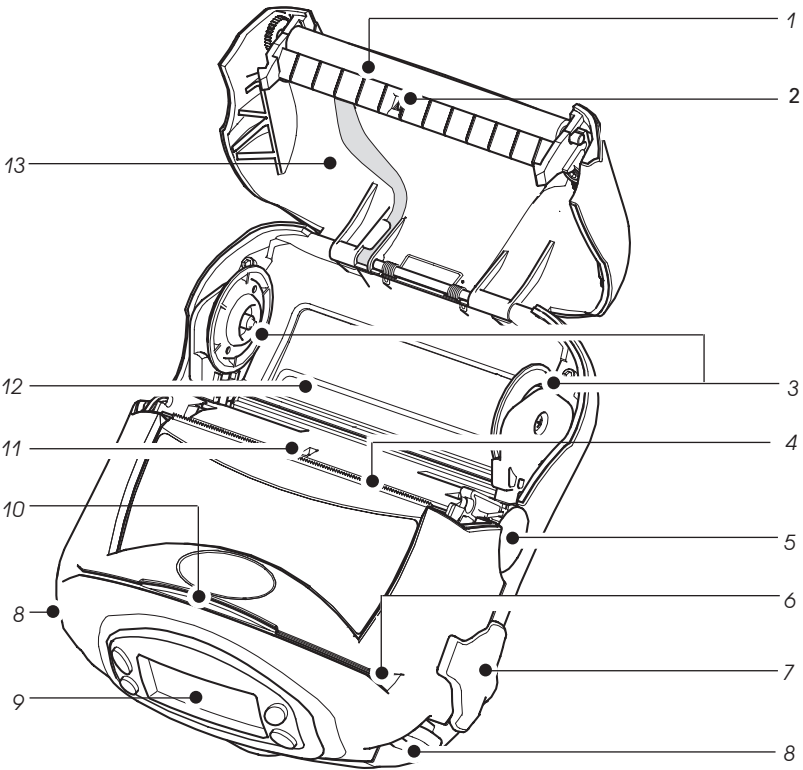

1. *Platen Roller*
2. *Bar Sensor*
3. *Media Support Disks*
4. *Printhead*
5. *Latch Release Button*
6. *Magnetic Stripe Reader (MSR) Slot*
7. *Communications Port Door*
8. *"D" Rings*
9. *Control Panel*
10. *Smart Card Slot*
11. *Gap Sensor*
12. *Bottom Media Feed Slot (external media models only)*
13. *Media Cover*

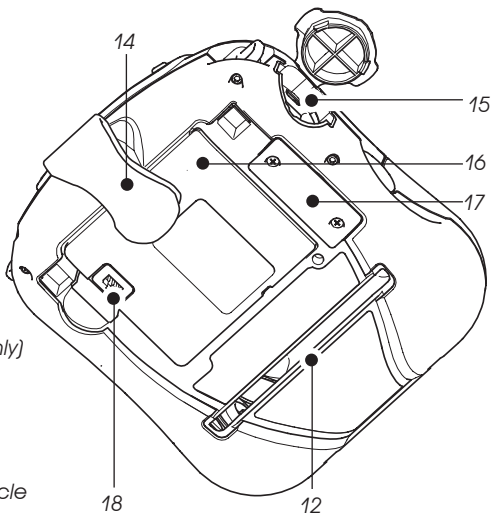



# Introduction to the RW 420

---

Thank you for choosing our Zebra RW 420 Mobile Printer. It is one of a series of rugged printers that are sure to become productive and efficient additions to your workplace thanks to their innovative design. Because the RW 420 is made by Zebra Technologies, you're assured of world-class support for all of your bar code printers, software, and supplies.

- This User's Guide gives you the information you'll need to operate and maintain your RW 420 printer.
- The RW 420 uses the CPCL programming language. To create and print receipts and labels using the CPCL language, refer to our Label Vista™ label creation program or the Mobile Printing Systems CPCL Programming Manual which are both available on our Web site at: <http://www.zebra.com>.
- The RW 420 includes interpreters for the ZPL II® programming language (up to Version 30.8.4) and the EPL programming language. Manuals for the ZPL and EPL label design programming languages are also available on our Web site. Refer to Appendix "E" of this manual for more information on accessing and downloading manuals and other user information.

## Unpacking and Inspection

Inspect the printer for possible shipping damage:

- Check all exterior surfaces for damage.
- Open the media cover (refer to "Loading the Media" in the Getting Ready to Print section) and inspect the media compartment for damage.

In case return shipping is required, save the carton and all packing material.

## Reporting Damage

If you discover shipping damage:

- Immediately notify and file a damage report with the shipping company. Zebra Technologies Corporation is not responsible for any damage incurred during shipment of the printer and will not cover the repair of this damage under its warranty policy.
- Keep the carton and all packing material for inspection.
- Notify your authorized Zebra re-seller.

**Figure 2: Installing the Battery**

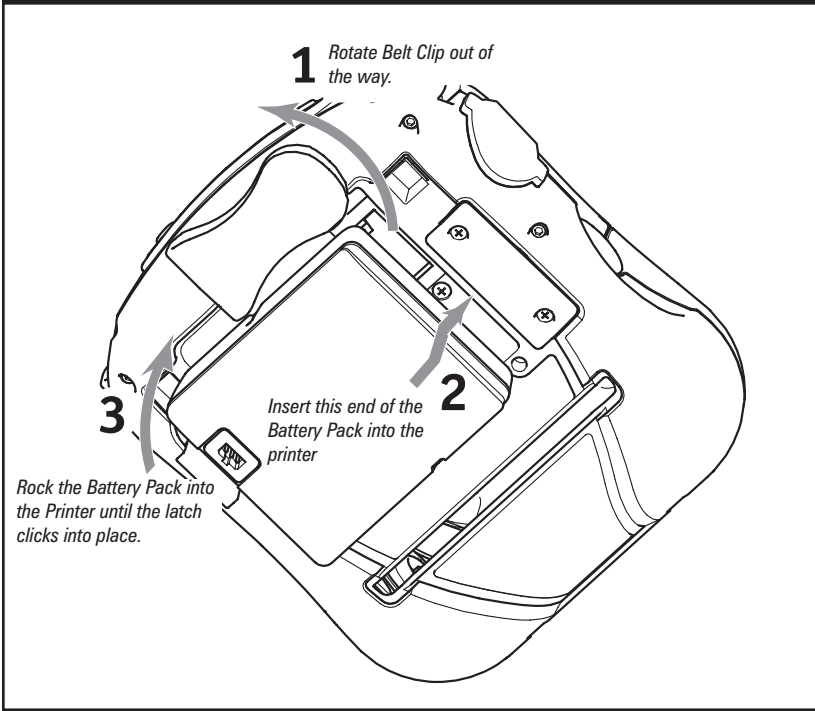

**Figure 3: Single Charger**

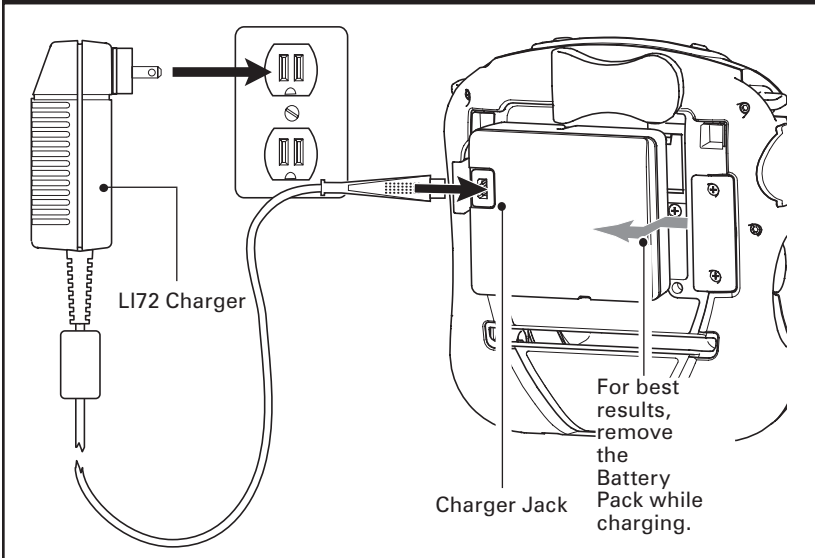

# Getting Ready to Print

## Battery

### Battery Safety

The Battery Packs used on Zebra Mobile Printers contain a great deal of energy and can cause personal injury or start a fire if used improperly or carelessly. Please observe the following safety practices:

 **Avoid accidental short circuiting of any battery. Allowing battery terminals to contact conductive material will create a short circuit which could cause burns and other injuries or could start a fire.**

 **Batteries can explode or catch fire if improperly charged or exposed to high temperatures or fire.**

**Do not disassemble, crush or expose batteries to water.**

**CAUTION: Use of any charger not approved specifically by Zebra for use with its batteries could cause damage to the battery pack or the printer and will void the warranty.**

### Installing the Battery



**NOTE:** Batteries are shipped uncharged. Remove protective shrink-wrap and labels from new battery packs prior to use.

1. Rotate the Belt Clip to allow access to the Battery compartment.
2. Insert the battery into the printer as shown in Figure 2,
3. Rock the Battery into the printer as shown until it locks in place.

When the battery is first installed, the Control Panel indicators may briefly turn on and then go off, indicating the battery is not fully charged (see “Charging the Battery” below and “Operator Controls.”)

### Charging the Battery

#### Model LI 72 Single Battery Charger

Refer to Figure 3. Your battery charger may look slightly different from the one illustrated.

1. Plug the Charger into the appropriate A.C. wall receptacle. Then insert the charge cable into the battery charger jack.
2. The charger LED will indicate the status of the charger as follows:
  - A steady light indicates the battery is undergoing a fast charge.
  - A slow blinking light indicates the charger is in trickle mode. The battery is ready for use.

- A rapidly blinking light indicates a problem with the battery. The battery may have an internal short, or its charge monitoring circuitry may be malfunctioning. The battery should not be used any further.



**Note:** While the LI 72 Charger allows Battery Packs to be charged when installed in the printer, best results are obtained with the battery removed.

**Do not attempt to print while charging batteries with the LI 72 charger. Attempting to print while charging can result in improperly charged batteries.**

## Model UCLI72-4 Quad Charger

### Charger Safety

**Use care in locating the Quad Charger. Do not place it in locations where liquids or metallic objects may be dropped into the charging bays. Do not block the ventilating slots on the top and bottom covers. Ensure that the Charger is plugged into a power source which won't accidentally be turned off if you will be charging batteries overnight.**

The UCLI72-4 Quad Charger is designed to charge up to four RW Series battery packs simultaneously. Batteries must be removed from the printer to be charged in the Quad Charger.

1. Ensure that the charger has been installed properly per the Quad Charger instruction manual. Ensure that the power indicator on the front panel is on.

2. Remove any protective shrink-wrap and labels from all battery packs prior to use. Plug a battery pack into any one of the four charging bays as shown in Figure 4, noting the orientation of the battery pack. Slide the battery pack into the charging bay until it stops. Then rock the battery pack back until it snaps into place. The amber indicator directly under the battery being charged will turn on if the battery is properly inserted.

The indicators under the battery will allow you to monitor the charging process per the table below:

Battery Status Indicators		
Amber LED	Green LED	Battery Status
On	Off	Charging
On	Flashing	80% charged (O.K. to use)
Off	On	Completely Charged
Flashing	Off	Fault

 **Note: A fault condition is caused by a problem with the battery. The charger may indicate a fault because the battery is too hot or cold to charge reliably. Try to charge the battery again when it returns to the room's ambient temperature. If the Amber indicator starts flashing on the second attempt, the battery should be discarded.**

Quad Charger Cycle Times for RW 420	
Battery Status	Time
Battery 80% Charged	2.5 Hrs
Battery Fully Charged	5 Hrs.

*NOTE: These times are for completely discharged batteries.*

Partially discharged Battery Packs will take less time to reach their charged state. Battery Packs which have reached 80% of their charge capacity may be used, however, it is recommended that you allow the batteries to reach a full charge to maintain maximum battery life.

The UCLI72-4 Quad Charger's safety features will stop charging a battery after six hours regardless of its charge state.

**Figure 4: UCLI72-4 Quad Charger**

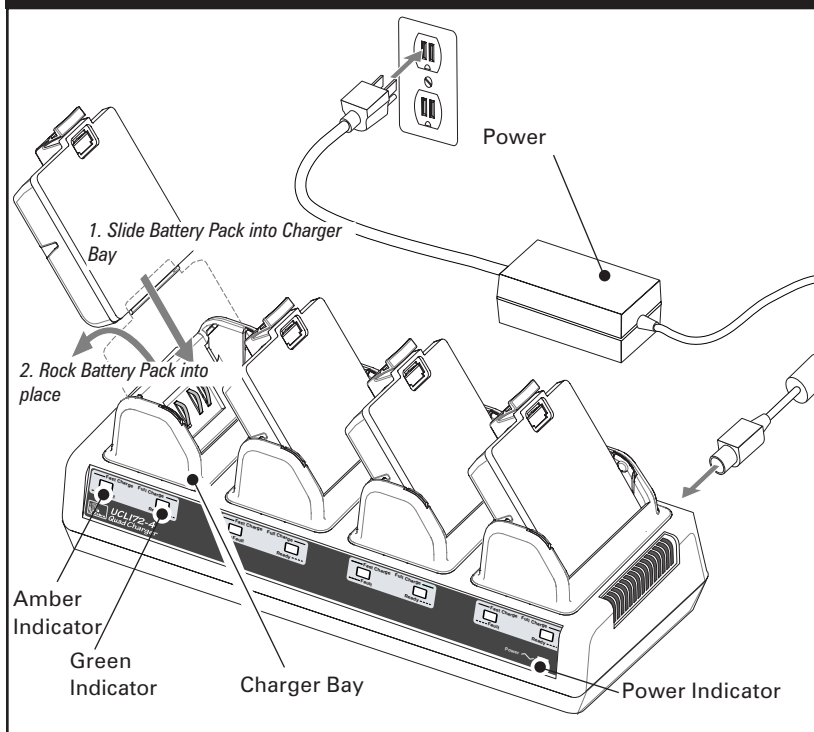

## Loading the Media

The RW 420 printer is designed to print either continuous (journal) media or label stock.

### Loading Media in the RW 420 Printer

1. Open the printer: Refer to Figure 5.
  - Press the latch release button on the side of the printer as shown at "1" below. The media cover will open automatically
  - Rotate the Media Cover back completely as shown at "2", exposing the media compartment and the adjustable media supports.

**Figure 5: Opening the Printer**

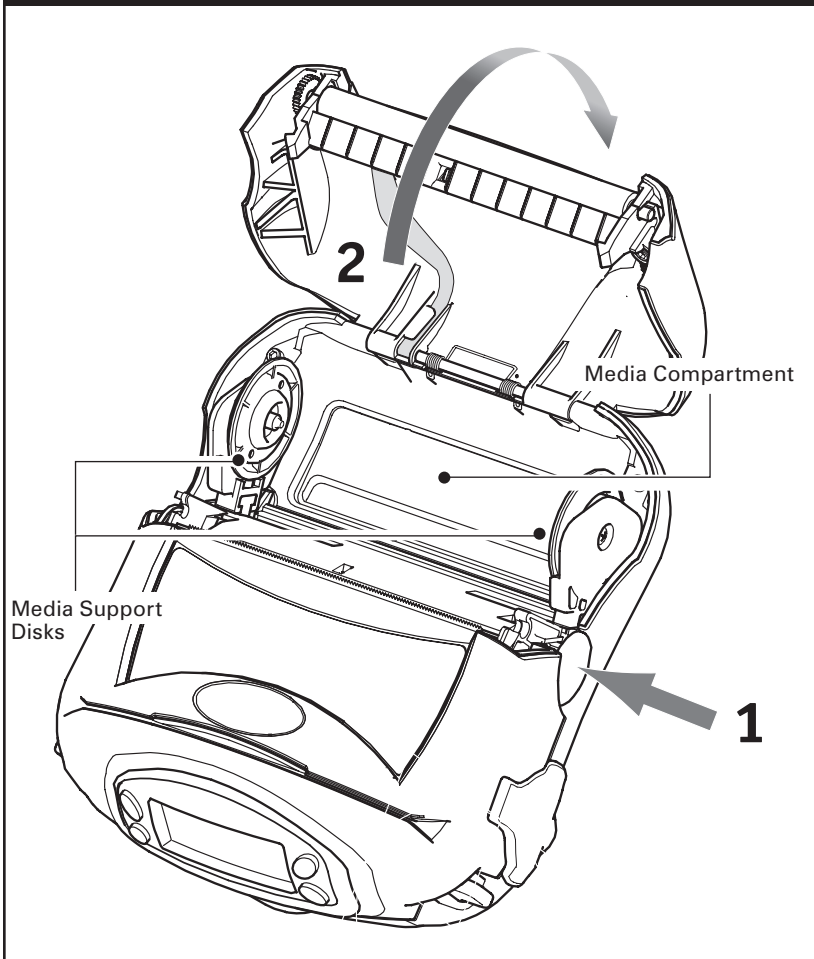

## Loading Media From An Internal Supply

- Refer to Figure 6. Pull the media supports apart, insert the roll of media between them, and let the media supports close. Ensure that the media pulls off the core in the direction shown in Figure 6. The supports will adjust themselves to the width of the media, and the roll of media should be able to spin freely on the supports.

**Figure 6: Loading Media from an Internal Supply**

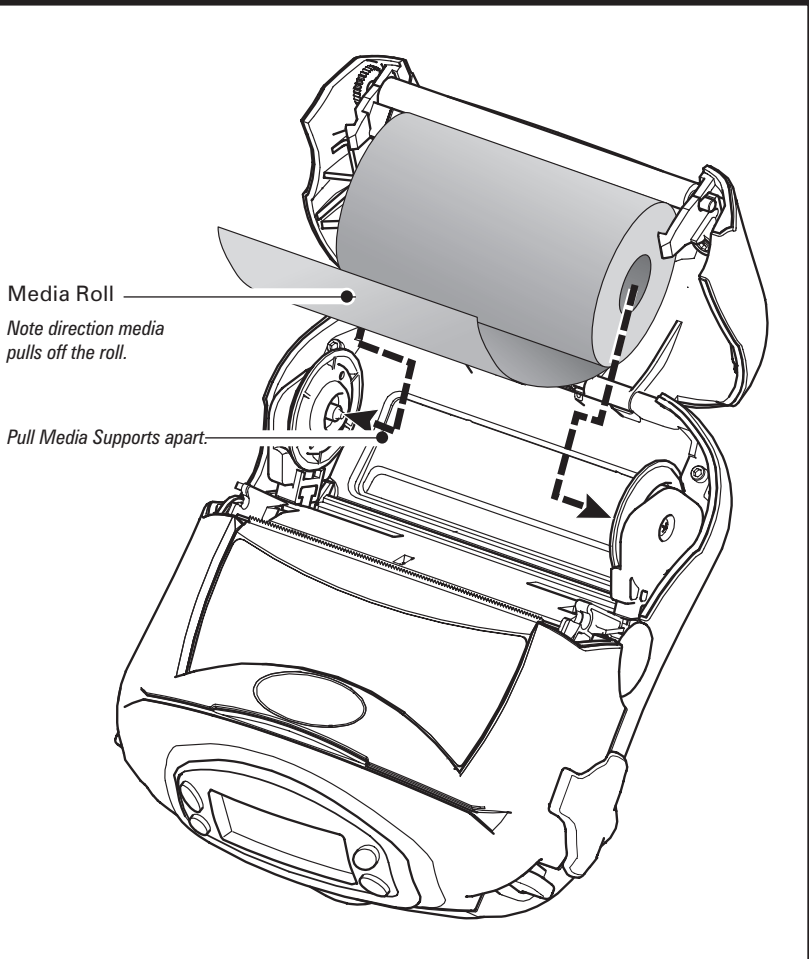

## Loading Media From An External Supply

Refer to Figure 7. The RW 420 configured with the External Media option has a loading slot in the rear of the media compartment allowing you to use standard 4 in. (101.6 mm) wide fanfold media from an external supply. The external supply must be designed such that it does not exert excessive drag as media is fed through the printer, which could result in distorted printing.

Zebra offers a series of vehicle cradles for the RW 420 (p/ns AK17463-003 and AK17463-004) which incorporate provisions for installation of an external media supply bin.

- Pull the media supports apart, insert a Media Spacer (Zebra part number BA16625-1) between them, and let the media supports close. Insert the media from the external supply through the rear feed slot, between the media guides and up through the media compartment as shown. Make sure the side of the media you will be printing on faces the printhead.

**Figure 7: Loading Media from an External Supply**

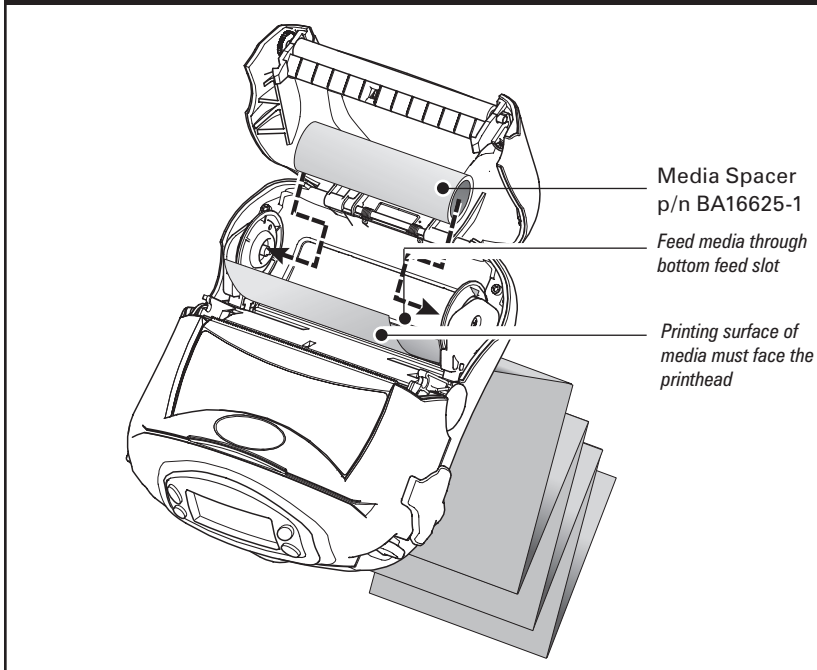



4. Close the Media Cover: Refer to Figure 8.

- Pull the media out of the printer as shown at "1."
- Close the media cover as shown at "2", ensuring that it latches securely into place.
- Turn the printer on or press the Feed button if the printer is already on.

The printer will advance a short strip of media and will then be ready for printing.

**Figure 8: Closing the Media Cover**

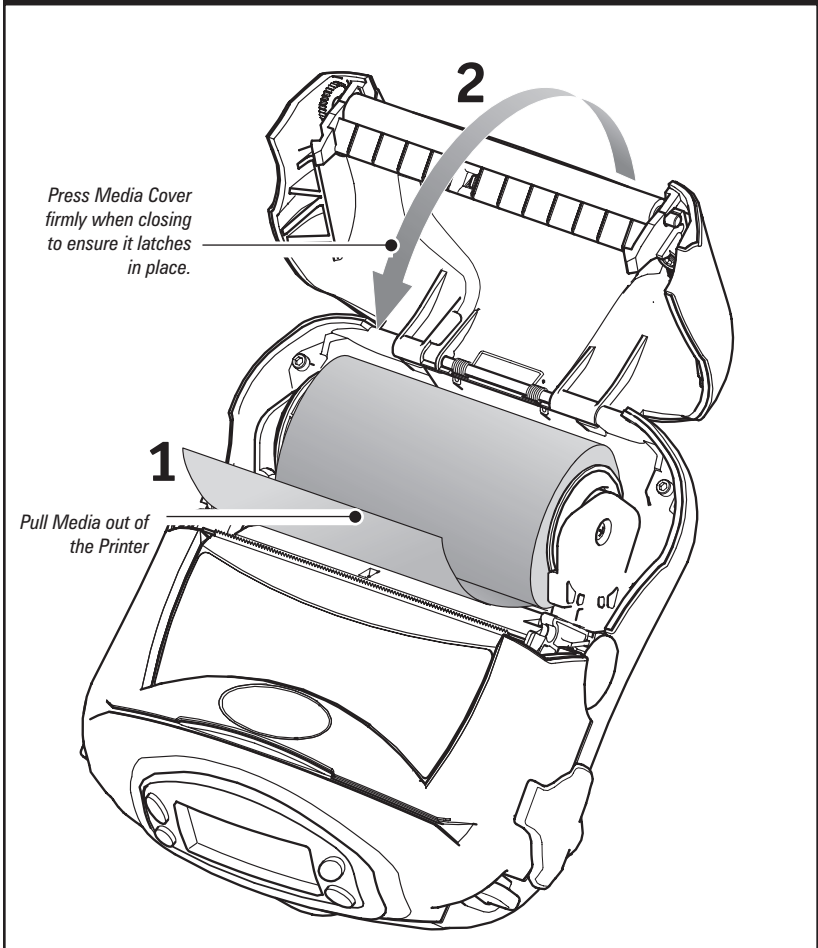

# Operator Controls







---

## Control Panel

The control panel has buttons for the power on/off and media feed functions and a display for providing information regarding printer functions. Two keys provide easy navigation and selection of menu options affecting many printer functions.

The "Scroll" button allows scrolling through the various options and settings. The "Select" button allows selection of the option or function displayed on the screen.

The top of the screen has a row of status icons which indicate the state of various printer functions:

-  Indicates a Bluetooth connection is established. A flashing icon indicates data transmission. This icon is functional only with RW 420 printers with a Bluetooth wireless option installed.
-  Indicates that the printer is associated with a wireless Local Area Network (LAN) using an 802.11b compliant radio. This icon is functional only with RW 420 printers with a WLAN wireless option installed.
-  A flashing icon indicates low battery status. You should suspend any printing operations and recharge or replace the Battery Pack as soon as is convenient.
-  A flashing icon indicates that the media cover is open or not properly latched.
-  A flashing icon indicates that a file is being downloaded to the printer.
-  A flashing icon indicates that the printer does not detect any media. This could indicate an out of media condition, or improperly loaded media.

In addition to the status icons, the LCD on the control panel can display many of the printer's settings and functions as text. Applications can be written to allow the user to view and /or modify these settings using the scroll and select keys on the display. Refer to the "LCD Functions Table" on the following pages for the full set of printer features that can be displayed.

The LCD has a backlighting option which allows viewing of the screen in a dark environment, or provides better contrast in a very bright environment. Use of the display backlight will decrease the time the printer will run between charges. Refer to the section “Extending Battery Life” for more information.

**Figure 10: LCD Control Panel**

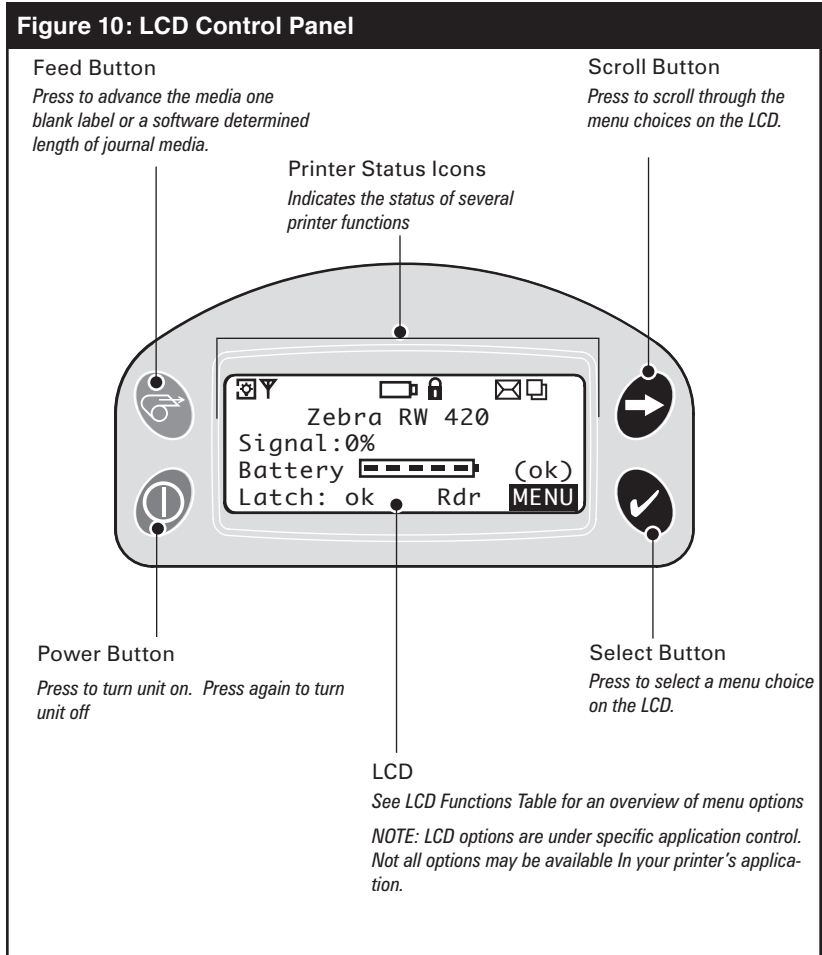

## Extended LCD Functions

Function	Default setting	Scroll & Select Options
Sensor Type	Bar	<ul style="list-style-type: none"> <li>• Bar</li> <li>• Gap</li> </ul>
Baud Rate	19200	<ul style="list-style-type: none"> <li>• 9600</li> <li>• 19200</li> <li>• 32400</li> <li>• 57600</li> <li>• 115200</li> </ul>
Data Bits	8	<ul style="list-style-type: none"> <li>• 7</li> <li>• 8</li> </ul>
Parity	N (none)	<ul style="list-style-type: none"> <li>• E (Even)</li> <li>• N (None)</li> <li>• O (Odd)</li> </ul>
LCD Contrast	8	<ul style="list-style-type: none"> <li>• Increase (15max.)</li> <li>• Increase (15 max.)</li> </ul>
No-activity Timeout <sup>1</sup>	120 sec.	<ul style="list-style-type: none"> <li>• Decrease (0 min.)</li> <li>• Increase (120 max.)</li> </ul>
Flip Screen	OFF	<ul style="list-style-type: none"> <li>• OFF</li> <li>• ON (The 4 text lines of display will be flipped 180 ° when the printer is in the Cradle Location of icons will remain unchanged.)</li> </ul>
Audio Volume	3	<ul style="list-style-type: none"> <li>• 1 – Low</li> <li>• 2 – Medium</li> <li>• 3 - High</li> </ul>
Media Type	Journal	<ul style="list-style-type: none"> <li>• Label</li> <li>• Journal</li> </ul>
LCD Backlight <sup>1</sup>	Momentary On	<ul style="list-style-type: none"> <li>• Momentary On w/ time delay</li> <li>• Off</li> </ul>
Factory Reset (Resets all to factory set values)	No	<ul style="list-style-type: none"> <li>• No</li> <li>• Yes</li> </ul>

<b>Display Functions Not Accessible from the Keypad<sup>4</sup></b>		
<b>Function</b>	<b>Default setting</b>	<b>Scroll &amp; Select Options</b>
WLAN ID <sup>2</sup>	Factory Set Value	N/A
Tear-off Position (Top of Form)	00	<ul style="list-style-type: none"> <li>• Increase (max. = +10)</li> <li>• Decrease (min. = -120)</li> </ul>
Network & RF Settings		<ul style="list-style-type: none"> <li>• All protocols ON</li> <li>• Protocols ON or OFF individually</li> </ul>
Bridge Mode	off	<ul style="list-style-type: none"> <li>• OFF</li> <li>• ON</li> </ul>
DTR/VBUS-Power Off	OFF	<ul style="list-style-type: none"> <li>• ON</li> <li>• OFF</li> </ul>
Present-at	000	<ul style="list-style-type: none"> <li>• Increase (max.= +120)</li> <li>• Decrease (min. = 000)</li> </ul>
Bluetooth parameters	n/a	Displays current Bluetooth operating parameters
802.11b WLAN parameters	n/a	Displays current 802.11b operating parameters
Media Type	Journal	<ul style="list-style-type: none"> <li>• Journal</li> <li>• Label</li> </ul>
Smart Card or MSR Card Reader Status <sup>3</sup>	Off	<ul style="list-style-type: none"> <li>• Off</li> <li>• Display "RDR"</li> </ul>

**NOTES:**

1. LCD Backlight turns on when any key other than FEED is pressed
2. Can be adjusted from the factory default using a PC running Zebra's Label Vista label creation program and a data cable link to the printer.
3. Card reader status is under application control, and is not user selectable.
4. The parameters listed above will appear on the display but can only be set using a PC running Zebra's Label Vista label creation program and a data cable link to the printer.

## Verify the Printer Is Working

---

Before you connect the printer to your computer or portable data terminal, make sure that the printer is in proper working order. You can do this by printing a configuration label using the “two key reset” method. If you can’t get this label to print, refer to “Troubleshooting.”

### Printing a Configuration Label

1. Turn the printer off. Load the media compartment with journal media (media with no black bars printed on the back)
2. Press and hold the Feed Button.
3. Press and release the Power button and keep the Feed button pressed. When printing starts, release the Feed button.

The unit will print a line of interlocking “x” characters to ensure all elements of the printhead are working, print out the version of software loaded in the printer and then print two reports.

The first report indicates model, ROM version, serial number, baud rate, etc. The second report prints out more detailed information on the printer’s configuration and parameter settings. If no second report appears, there is no application loaded. (See the Troubleshooting Section for a sample print-out and a further discussion on how to use the configuration label as a diagnostic tool.)

## Connecting the Printer

The printer must establish communications with a host terminal which sends the data to be printed. Communications occur in three basic ways:

- By a cable between the printer and its host terminal using either RS232C or USB protocols.
- By means of a Bluetooth short-range radio frequency link.
- By means of a wireless LAN (Local Area Network) per 802.11b specifications.



*While the RW 420 can be equipped with both a Bluetooth radio and a 802.11b radio they cannot be operated concurrently.*

## Cable Communications

**Figure 11: Communications Port**

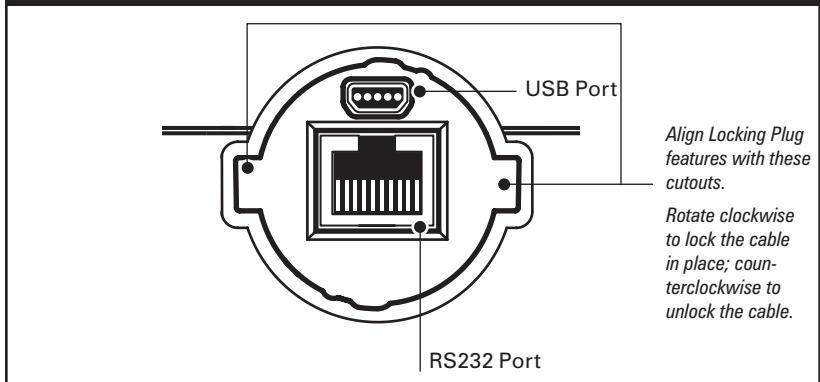

### Serial (RS232C)

**CAUTION.** *The power should be turned off before connecting or disconnecting the communications cable.*

All RW 420 printers can communicate by cable; the specific cable supplied with your printer will vary with the host terminal. The 10-pin modular connector on your communications cable plugs into the serial (RS232C) communications port on the side of the printer. Plug the connector into the RS232C port and ensure the locking device has clicked into position. Then press the Locking Plug into the opening around the connector, aligning its locking features with the cutouts on the RW 420 case. Turn the Locking Plug clockwise one-quarter turn to secure it in place.

The other end of the cable must be plugged into the host terminal as shown in Figure 12, or to a serial port on a com-

puter as shown in Figure 13. Communications between the terminal and the printer are controlled by the applications running on the terminal and the printer.

## USB

RW 420 Printers also can communicate by cable via the USB protocol. The USB port is a USB Mini-AB type connector located directly above the 10-pin modular connector used for RS232C communications. (Refer to Figure 11)

The RW 420 is configured with the USB Open HCI interface driver allowing it to communicate with Windows® based devices. (USB drivers are included in the Zebra Universal Driver

**Figure 12: Communications to a Terminal**

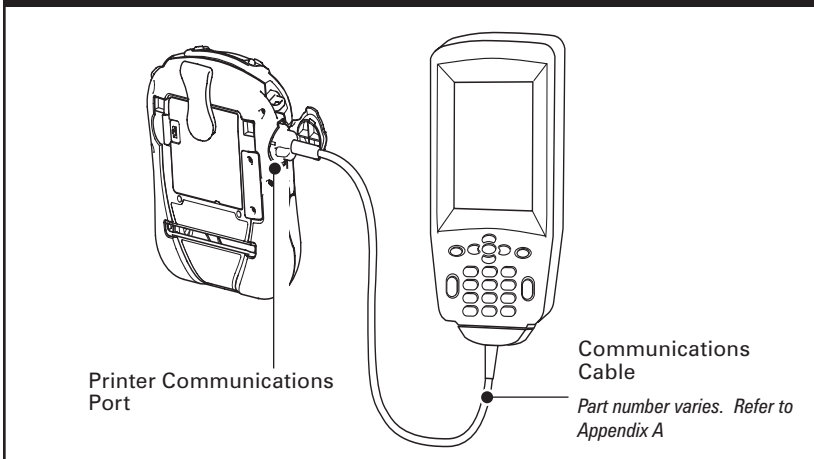

**Figure 13: Communications to a PC**

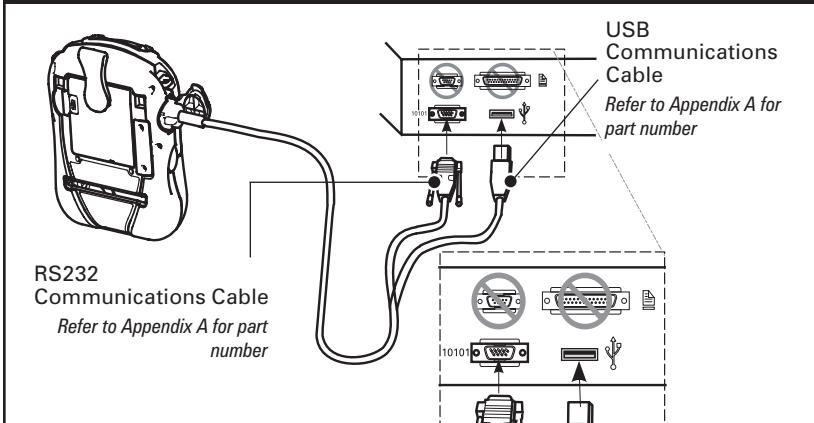



---

which can be downloaded from [www.zebra.com/drivers](http://www.zebra.com/drivers).) Other terminals or communications devices may require the installation of special drivers to use the USB connection. Consult the factory for further details.

## Wireless Communications

### Wireless Communications with Bluetooth®



*The following section only applies when the ZBR3 Bluetooth Radio (FCC ID: I28MD-BTC2TY2) is installed in a RW 420. The antenna used for this transmitter must not be co-located or must not operate in conjunction with any other antenna.*

“Bluetooth” is a worldwide standard for the exchange of data between two devices via radio frequencies. Bluetooth radios are relatively low powered to help prevent interference with other devices running at similar radio frequencies. This limits the range of a Bluetooth device to about 10 meters (about 32 feet).

Both the printer and the device it communicates with must follow the Bluetooth standard.

#### *Bluetooth Networking Overview*

Bluetooth software is always running in the background, ready to respond to connection requests. One device (known as the *master* or the *client*) must request a connection with another. The second device (the *slave* or the *server*) then accepts or rejects the connection. A Bluetooth enabled RW 420 printer will normally act as a slave creating a miniature network with the terminal sometimes referred to as a “piconet.”

For the most part, communications using Bluetooth are initiated and processed without any operator intervention.

Each Bluetooth enabled RW 420 printer has a unique Bluetooth Device Address (BDA) loaded into its radio module when manufactured.

continued



### **Exposure to Radio Frequency Radiation**

***The radiated output power of this internal Bluetooth radio is far below the FCC radio frequency exposure limits. Nevertheless, this Bluetooth radio must be used in such a manner that the antenna is 2.5 cm. or further from the human body.***

***The radio and antenna are mounted internally in this printer such that when the printer is worn with the back of the printer against the body and the front of the printer (where paper exits) away from the body, then the 2.5 cm distance between the antenna and the users body will be met. Do not use the printer in an unauthorized manner.***

***The internal Bluetooth radio operates within guidelines found in radio frequency safety standards and recommendations. The level of energy emitted is far less than the electromagnetic energy emitted by other wireless devices such as mobile phones.***

### **European Regulatory Information for the ZBR3 Bluetooth Radio**

This device is intended for use in all EU and EFTA member states.

#### **Europe – EU Declaration of Conformity**

This device complies with the essential requirements of the R&TTE Directive 1999/5/EC. The following test methods have been applied in order to prove presumption of compliance with the R&TTE Directive 1999/5/EC:

- EN 60950: 2000  
Safety of Information Technology Equipment
- EN 300 328-2 V1.4.1 (2003-04)

<b>CE 0336</b>	<b>Important Notice:</b> This device is a portable RF printer intended for commercial and industrial use in all EU
----------------	---

---

## Wireless Local Area Network Overview

RW 420 printers can be equipped with several radio options which use the industry standard 802.11b protocol.

- RW 420 printers with a Compact Flash (CF) radio module can be identified by the FCC ID number "I28MD-RW4137" and other regulatory information on the serial number label on the back of the unit.
- RW 420 printers with a Zebra 802.11b radio module can be identified by the FCC ID number "I28MD-ZLAN11B" and other regulatory information on the serial number label on the back of the unit.

Printers so equipped allow wireless communication as a node within a Wireless Local Area Network (WLAN) and its wireless capabilities allow communications from any point within the WLAN's perimeter.

Methods of establishing communications to RW series printers will vary with each LAN application. General information on establishing WLAN communications can be found in either the "CPCL Programmers Manual" or the "Quick Start Guide for Mobile Wireless Printers" both available on-line. More information and LAN configuration utilities may also be found in Zebra's Label Vista™ program (version 2.8 and later). Label Vista may be downloaded from the Zebra Web site.

continued

---

## Compact Flash (802.11b) Radio Module

The following section only applies when the CF (Compact Flash) WLAN module (With FCC ID: I28MD-RW4137) is installed in a RW 420 printer (note that only one of the radio options can be installed in the printer at one time). The FCC ID number is on the serial number label on the back of the printer and can be read with the module installed.

**WARNING: Use of a RW 420 printer with the radio module marked with "FCC ID: I28MD-RW4137" meets the FCC requirements for radio frequency (RF) radiation exposure in the standard body worn configuration with no minimum separation. In this configuration, which applies whether the belt clip or shoulder strap is used, the face of the printer from which paper is transported is facing away from the user's body. The standard configuration must always be used when the printer is body worn.**

**RW 420 printers with this radio option have been SAR tested. The maximum SAR value measured for each model was 0.062 W/kg averaged over 1 gram.**

### European Regulatory Information for this Radio

AT	BE	CY	CZ	DK
EE	FI	<del>FR</del>	DE	GR
HU	IE	IT	LV	LT
LU	MT	NL	PL	PT
SK	SI	ES	SE	GB

Note: -Member states in the EU with restrictive use for this device are crossed out!

This device is also authorized for use in all EFTA member states (CH, IS, LI, NO)

 <b>0336</b> 	<b>Important Notice:</b> This device is a portable RF printer intended for commercial and industrial use in all EU and EFTA member states except in France where
---	---

continued

## Europe – EU Declaration of Conformity

This device complies with the essential requirements of the R&TTE Directive 1999/5/EC. The following test methods have been applied in order to prove presumption of compliance with the R&TTE Directive 1999/5/EC:

- EN 60950: 2000  
Safety of Information Technology Equipment
- EN 300 328-2 V1.2.1 (2001-12)  
Technical requirements for spread-spectrum radio equipment
- EN 301 489-17 V1.2.1 (2002-08)  
EMC requirements for spread-spectrum radio equipment.

This device is a 2.4 GHz wireless LAN transceiver, intended for indoor home and office use in all EU and EFTA member states, except in France where restrictive use applies.

The use of this frequency band in France is subject to restrictions. You may only use channels 10 and 11 (2457 and 2462 MHz) on French territory, except in those French departments as listed in the table below where channels 1-13 (2412-2472 MHz) may be used. For more information see <http://www.anfr.fr/> and/or <http://www.art-telecom.fr>

01	Ain	36	Indre	69	Rhone
02	Aisne	37	Indre et Loire	70	Haute Saone
03	Allier	39	Jura	71	Saone et Loire
05	Hautes Alpes	41	Loir et Cher	72	Sarthe
08	Ardennes	42	Loire	75	Paris
09	Ariege	45	Loiret	77	Seine et Marne
10	Aube	50	Manche	78	Yvelines
11	Aude	54	Meurthe et Moselle	79	Deux Sievres
12	Aveyron	55	Meuse	82	Tarn et Garonne
16	Charente	57	Moselle	84	Vaucluse
19	Correze	58	Nievre	86	Vienne
2A	Corse Sud	59	Nord	88	Vosges
2B	Haute Corse	60	Oise	89	Yonne
21	Cote d'Or	61	Orne	90	Territoire de Belfort
24	Dordogne	63	Puy de Dome	91	Essonne
25	Doubs	64	Pyrenees Atlantique	92	Hauts de Seine
26	Drome	65	Hautes Pyrenees	93	Seine St Denis
27	Eure	66	Pyrenees Orientales	94	Val de Marne
32	Gers	67	Bas Rhin		
35	Ille et Vilaine	68	Haute Rhin		

---

## Zebra 802.11b Radio Module

The following section only applies when the Zebra 802.11b radio module (With FCC ID: I28MD-ZLAN11B) is installed in a RW 420 printer (note that only one of the radio options can be installed in the printer at one time). The FCC ID number is on the serial number label on the back of the printer and can be read with the module installed.



 **The radiated output power of this internal 802.11b radio is far below the FCC radio frequency exposure limits. Nevertheless, this radio must be used in such a manner that the antenna is 2.5 cm. or further from the human body. The radio and antenna are mounted internally in this printer such that when the printer is worn with the back of the printer against the body and the front of the printer (where paper exits) away from the body, then the 2.5 cm distance between the antenna and the users body will be met. Do not use the printer in an unauthorized manner.**

### European Regulatory Information for this Radio

AT	BE	CY	CZ	DK
EE	FI	<del>FR</del>	DE	GR
HU	IE	IT	LV	LT
LU	MT	NL	PL	PT
SK	SI	ES	SE	GB

Note: -Member states in the EU with restrictive use for this device are crossed out!

This device is also authorized for use in all EFTA member states (CH, IS, LI, NO)

 <b>0336</b> 	<b>Important Notice:</b> This device is a portable RF printer intended for commercial and industrial use in all EU and EFTA member states except in France where
---	---

---

## Europe – EU Declaration of Conformity

This device complies with the essential requirements of the R&TTE Directive 1999/5/EC. The following test methods have been applied in order to prove presumption of compliance with the R&TTE Directive 1999/5/EC:

- EN 60950: 2000
- Safety of Information Technology Equipment
- EN 300 328-2 V1.2.1 (2001-12)
- Technical requirements for spread-spectrum radio equipment
- EN 301 489-17 V1.2.1 (2002-08)
- EMC requirements for spread-spectrum radio equipment.

This device is a 2.4 GHz wireless LAN transceiver, intended for indoor home and office use in all EU and EFTA member states, except in France where restrictive use applies.

The use of this frequency band in France is subject to restrictions. You may only use channels 10 and 11 (2457 and 2462 MHz) on French territory, except in those French departments as listed in the table below where channels 1-13 (2412-2472 MHz) may be used. For more information see <http://www.anfr.fr/> and/or <http://www.art-telecom.fr>

01	Ain	36	Indre	69	Rhone
02	Aisne	37	Indre et Loire	70	Haute Saone
03	Allier	39	Jura	71	Saone et Loire
05	Hautes Alpes	41	Loir et Cher	72	Sarthe
08	Ardennes	42	Loire	75	Paris
09	Ariege	45	Loiret	77	Seine et Marne
10	Aube	50	Manche	78	Yvelines
11	Aude	54	Meurthe et Moselle	79	Deux Sievres
12	Aveyron	55	Meuse	82	Tarn et Garonne
16	Charente	57	Moselle	84	Vaucluse
19	Correze	58	Nievre	86	Vienne
2A	Corse Sud	59	Nord	88	Vosges
2B	Haute Corse	60	Oise	89	Yonne
21	Cote d'Or	61	Orne	90	Territoire de Belfort
24	Dordogne	63	Puy de Dome	91	Essonne
25	Doubs	64	Pyrenees Atlantique	92	Hauts de Seine
26	Drome	65	Hautes Pyrenees	93	Seine St Denis
27	Eure	66	Pyrenees Orientales	94	Val de Marne
32	Gers	67	Bas Rhin		
35	Ille et Vilaine	68	Haute Rhin		

---

## Setting Up the Software

RW series printers use Zebra's CPCL Programming language which was designed for mobile printing applications. CPCL is fully described in the "CPCL Programmers Manual", available on-line from the [\*Zebra Web site\*](#).

You can also use Label Vista™, Zebra's Windows® based label creation program which uses a graphical interface to create and edit labels in the CPCL language. Label Vista is available on-line from [\*Zebra's Web site\*](#).

RW series printers with an optional memory upgrade can support an interpreter for ZPL II®, or EPL programming languages. RW Plus series printers have these interpreters loaded as a standard part of their operating system.

If you plan to use ZPL II or EPL, refer to the appropriate Programming Guides available on-line from [\*Zebra's Web site\*](#). If you choose to use a third party label preparation system, follow the installation instructions included in the package.



## Card Reader Options

The RW 420 can be equipped with optional Magnetic Stripe and Smart Card readers. The magnetic stripe card reader allows the user to swipe magnetic stripe cards such as credit cards through a slot in the printer and then read and process the data contained in the card.

In a similar manner the Smart Card reader can read the information written in the microchip embedded in Smart Cards, and process the information in the chip in a variety of ways depending on the printer's application.

**Figure 14: Magnetic Stripe Reader Status Indicator**

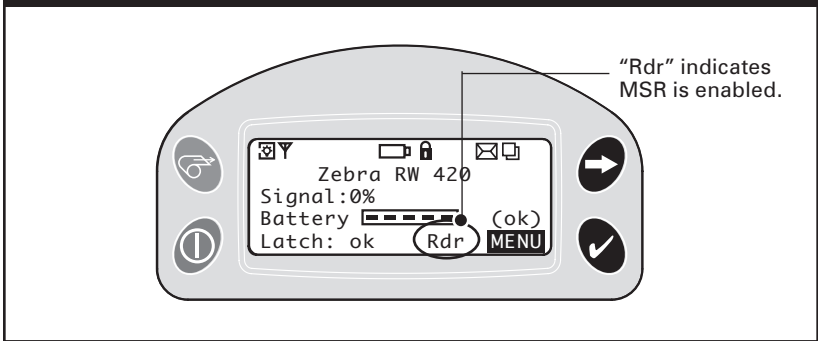

### Magnetic Stripe Reader

The status of the Magnetic Stripe Reader (MSR) is indicated in three possible ways:

- Reader status is displayed on the Main Menu LCD as shown above in Figure 14.
- The LCD backlight flashes to indicate status (3 flashes = enabled, 2 flashes = disabled).
- Chimes indicates the reader status (3 chimes = enabled, 2 chimes = disabled).

The MSR is used as follows:

1. When the reader is enabled, place the card into the reader slot as shown. The magnetic stripe (typically on the back of the card) must face the bottom of the printer, and be inserted into the bottom of the card reader slot as shown in Figure 15.
2. Slide the card through the slot. The card will be read if slid in either direction. Depending on the application software, the printer will sound one chime when a scan is successful .
3. If the card did not read, slide it back through the slot in the opposite direction.

**Figure 15: Using the Magnetic Stripe Reader**

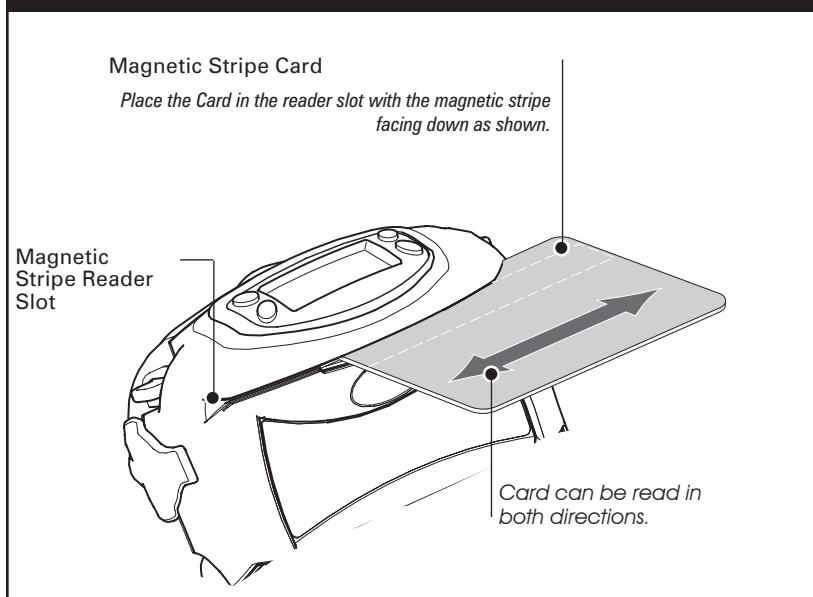

---

## Smart Card Reader

The optional Smart Card reader is used as follows:

1. The LCD will display "RDR" to indicate the Smart Card reader is active. (Some reader applications may flash the display backlight and/or chime three times to indicate the reader status is "ready.") At this time, the Printer is acting only as a Smart Card reader connected to the host terminal; all other printer functions are suspended.
2. Insert the card into the reader slot as shown in Figure 16. The microchip imbedded in the card must be oriented facing the bottom of the printer and must be completely inserted into the Reader Slot to scan successfully .
3. Depending on the application software, the printer will sound a chime after a successful transaction.
4. After the card has been successfully read the Printer can resume normal printing operations and the Smart Card can be removed.

**Figure 16: Using the Smart Card Reader**

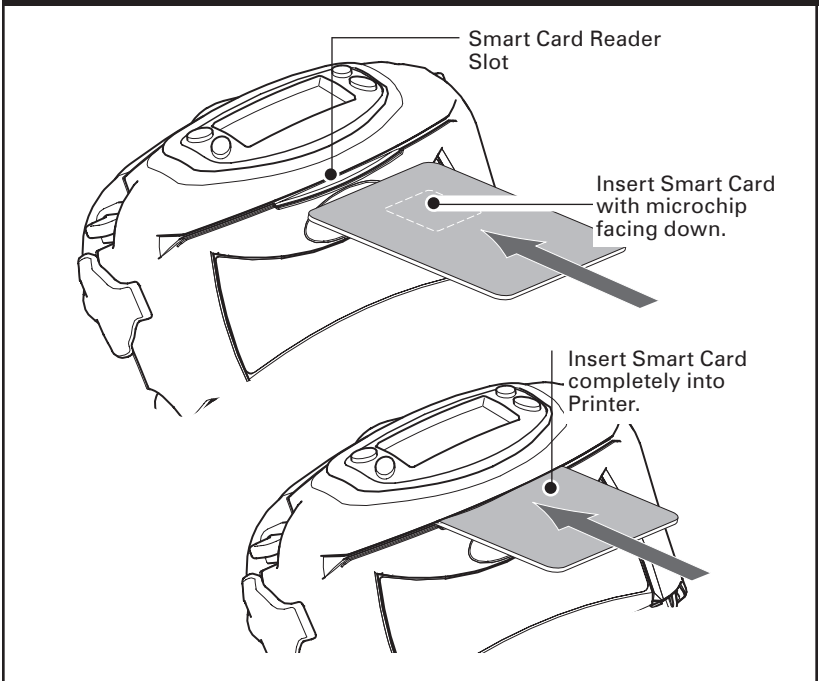

## Using the Accessories

### Belt Clip

Refer to Figure 17. All RW 420 printers are equipped with a belt clip as standard. To use: hook the clip over your belt, and ensure that the clip is securely attached to the belt. The belt clip will pivot to allow you to move freely while wearing the printer.

Figure 17: Using the Belt Clip

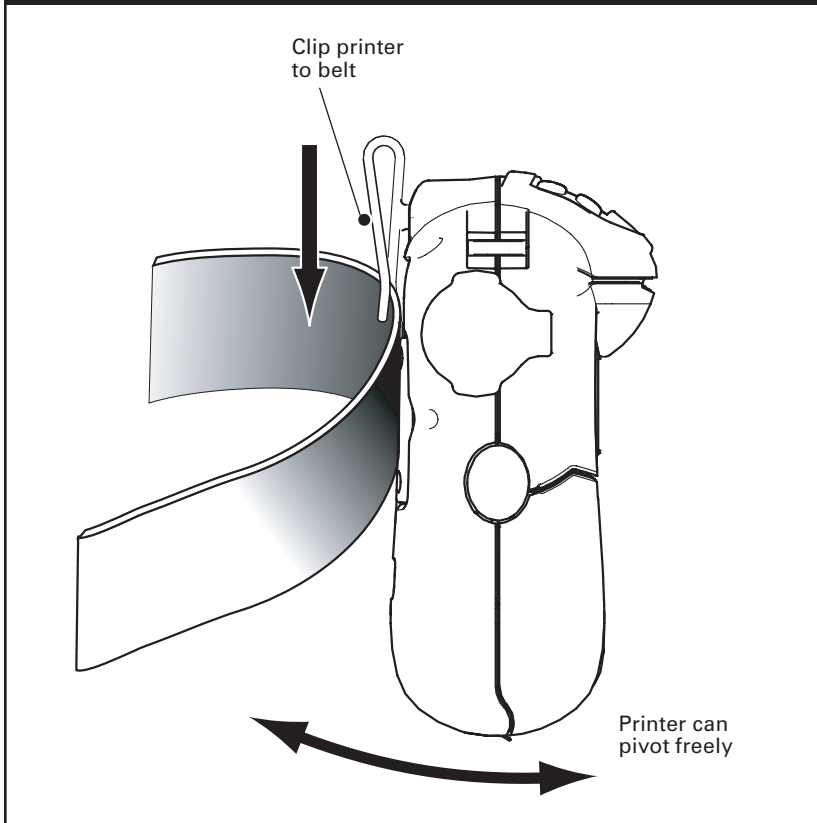

## Adjustable Shoulder Strap

Refer to Figure 18. If your printer is equipped for the shoulder strap option: snap each end of the shoulder strap into the "D" rings in the top of the printer. Slide the buckle away from or towards the printer until you achieve the desired length.

**Figure 18: Using the Shoulder Strap**

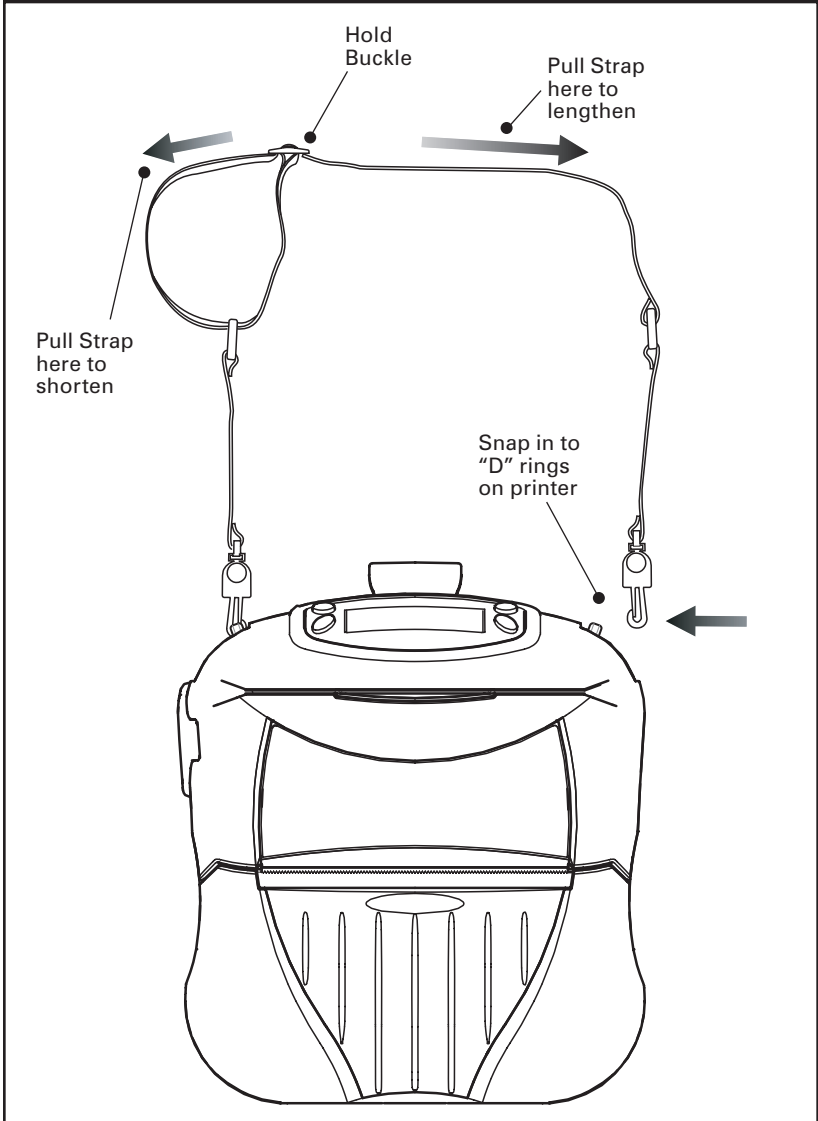

## Cradle

The RW 420 can be used in conjunction with a docking Cradle. When the printer is “docked” the Cradle will charge the printer’s battery and allow the printer to print, receive and transmit data as usual. The Cradle can provide power from a 12 VDC power supply either from a power take-off point in a vehicle or from an external power supply running off A.C. power. Refer to the documentation supplied with the Cradle for more information.

### Installing the Printer in the Cradle

 ***It is recommended as a safety precaution that the adjustable shoulder strap be removed prior to docking the Printer. This precaution ensures the strap will not interfere with proper operation of the vehicle.***

- Remove the Docking Connector Cover from the bottom of the printer, and retain it for future use. (Refer to Figure 20.)
- Place the bottom of the printer over the two pins in the Cradle.
- Rock the top of the Printer into the Cradle and press firmly until it latches in place.
- Ensure the Cradle power indicator is lit and turn the printer on.

You can load media (including media from an external supply) and perform cleaning operations normally when the RW 420 Printer is installed in the Cradle .

The RW 420 will allow the four display lines on the control panel to be rotated 180° when the printer is docked. This allows for easier reading of the display when the Cradle is mounted vertically. Refer to Figure 19.

**Figure 19: Display Rotated for Cradle Installation**

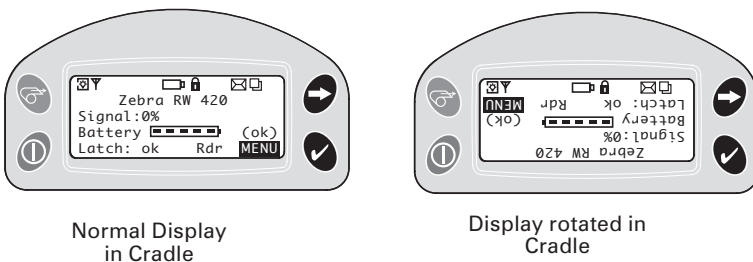

**Figure 20: Installing the Printer into the Cradle**

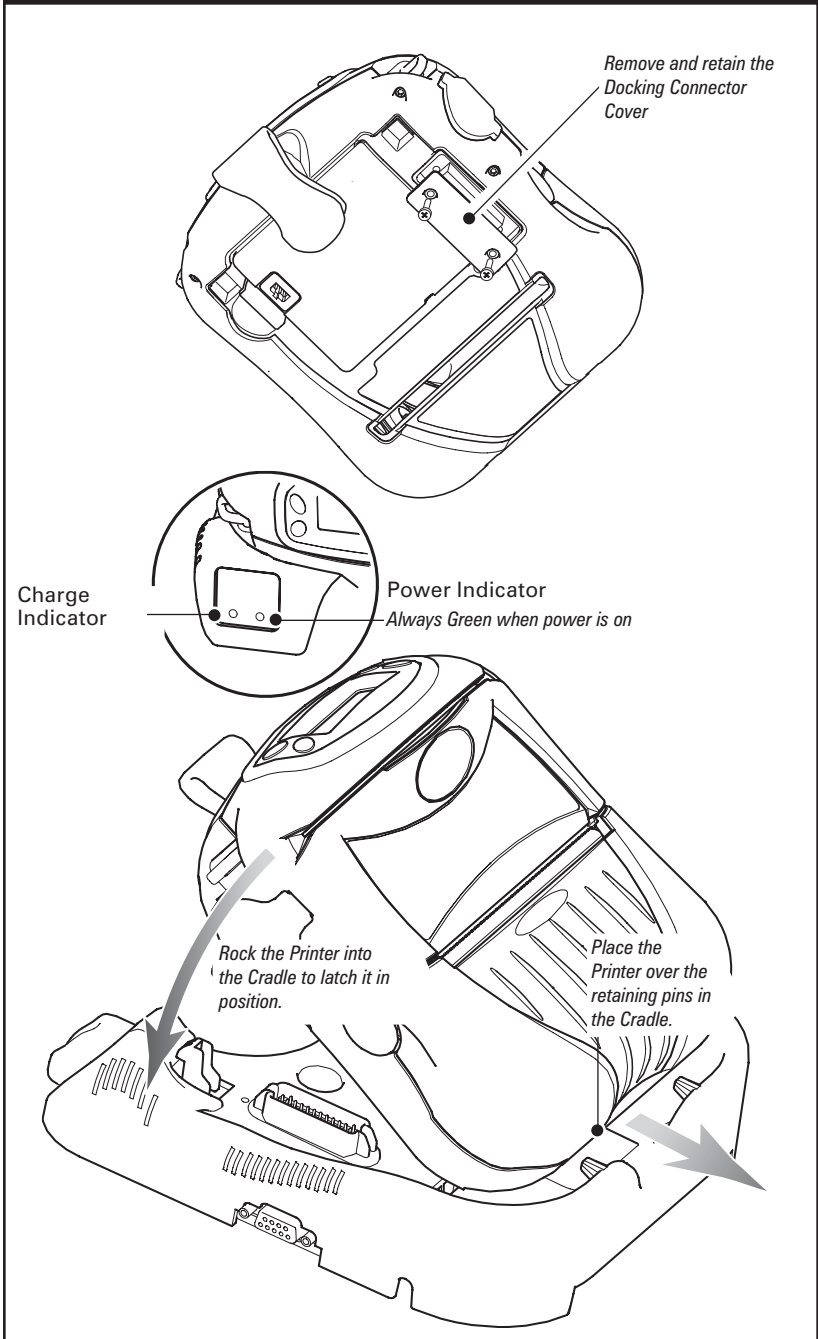

## Removing the Printer from the Cradle

Refer to Figure 21.

- Turn the Printer off.
- Push on the latch on the Cradle and rock the top of the printer away from the Cradle.
- Lift the Printer out from the Cradle.

Replace the Docking Connector Cover if you will be using the Printer for an extended period of time away from the Cradle.

**Figure 21: Removing the Printer from the Cradle**

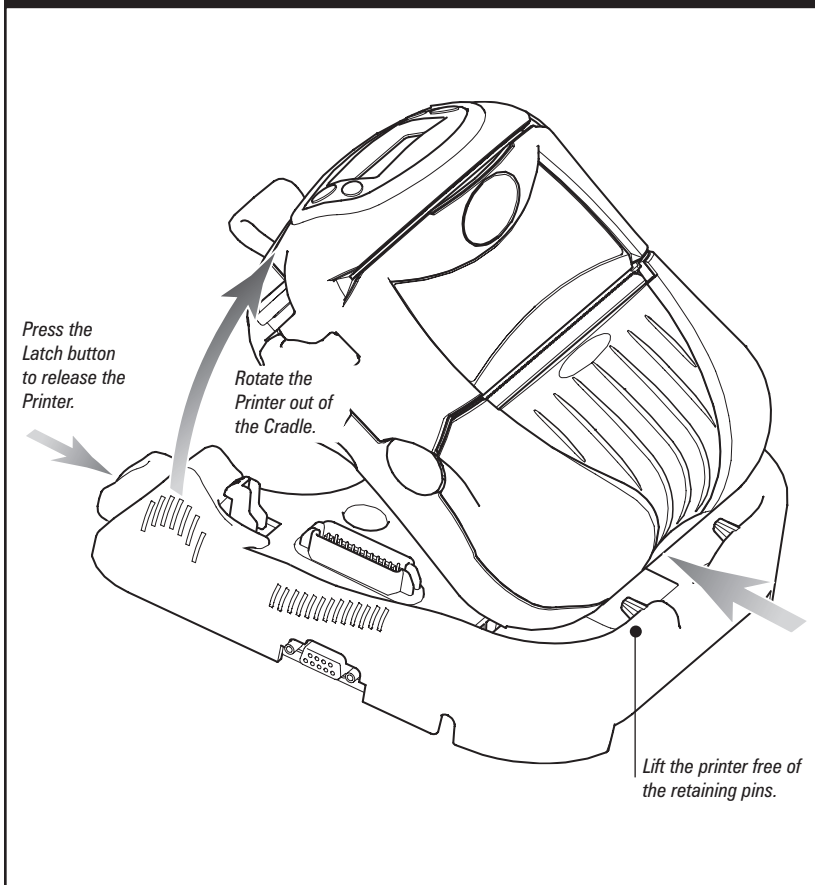



# Preventive Maintenance

---

## Extending Battery Life

- Avoid exposing the battery to direct sunlight or temperatures over 104° F (40° C).
- Always use a Zebra charger designed specifically for Lithium-Ion batteries. Use of any other kind of charger may damage the battery.
- Use the correct media for your printing requirements. An authorized Zebra re-seller can help you determine the optimum media for your application.
- If you print the same text or graphic on every label, consider using a preprinted label.
- Choose the correct print darkness, and print speed for your media.
- Use software handshaking (XON/XOFF) whenever possible.
- If your printer has the optional LCD display, use the display backlight only when necessary. Turn it off whenever it is not needed.
- Remove the battery from the printer if it won't be used for a day or more and you're not performing a maintenance charge.
- Consider purchasing an extra battery.
- Remember that any rechargeable battery will lose its ability to maintain a charge over time. It can only be recharged a finite number of times before it must be replaced. Always dispose of used batteries properly. Refer to Appendix D for more information on proper battery disposal.
- Don't print while the LI 72 Wall Charger is plugged into the unit. Unreliable battery charging can result.

## Cleaning Instructions



**CAUTION-** Use only cleaning agents specified. Zebra Technologies Corporation will not be responsible for damage caused by any other cleaning materials used on this printer.

*Clean the printer with either the cleaning pen supplied with the printer or a cotton swab saturated with alcohol.*



**WARNING:** To avoid possible personal injury or damage to the printer, never insert any pointed or sharp objects into the printer. The Tear Bar has sharp edges. Use care when cleaning the Tear Bar or the Printhead to avoid possible personal injury.

## RW 420 Cleaning

Area	Method	Interval
Printhead (Figure 22)	Use the supplied cleaning pen or 70% isopropyl alcohol on a cotton swab to clean the print elements from end to end (the print elements are located in the thin gray line on the printhead).	After every five rolls of media (or more often, if needed)
Tear bar (Figure 22)	Clean thoroughly with the cleaning pen or 70% isopropyl alcohol and a cotton swab.	
Platen Roller (Figure 22)	Rotate the platen roller and clean it thoroughly with the cleaning pen or 70% isopropyl alcohol and a cotton swab.	
Exterior	Water-dampened cloth	As needed
Interior (Figure 22)	Brush/air blow. Ensure the Bar Sensor and Gap Sensor windows are free of dust.	After every five rolls of media (or more often, if needed)



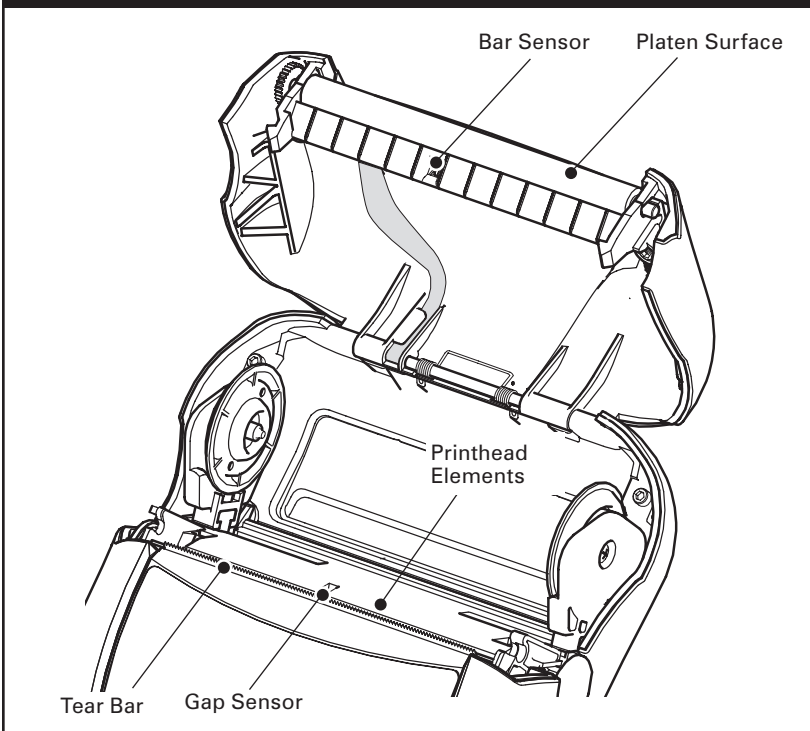



**Figure 22: Cleaning the RW 420**



# Troubleshooting

## LCD Control Panel Indicators

The top of the display shows several icons which indicate various printer functions. Check the indicator status, then refer to the Troubleshooting topic referenced in the chart to resolve the problem.

Status Icon	Condition	Indication	Ref. to Topic #
	Steady	802.11b RF Link established	n/a
	Off	No 802.11b RF Link	6
	Steady	Bluetooth Link established	n/a
	Flashing	Transmitting/Receiving via Bluetooth	n/a
	Off	No Bluetooth Link	6
	Flashing	Low Battery	3, 6, 7
	Flashing	Head latch not closed	9, 11
	Steady	data processing in process	8
	Flashing	Out of Media	9,11
Blank Screen	n/a	No application	1,13

---

## Troubleshooting Topics

### 1. *No power*

- Check that battery is installed properly
- Recharge or replace battery as necessary. (Always dispose of used batteries properly. Refer to Appendix D for more information on proper battery disposal.)

### 2. *Media does not feed:*

- Ensure Media Cover is properly closed and latched.
- Check media supports for any binding.

### 3. *Poor or faded print or flashing icon:*

- Clean print head.
- Check battery and recharge or replace as necessary.
- Check quality of media.

### 4. *Partial/missing print:*

- Check media alignment.
- Clean print head.
- Ensure Media Cover is properly closed and latched.

### 5. *Garbled print:*

- Check baud rate.

### 6. *No print:*

- Check baud rate.
- Replace battery. Always dispose of used batteries properly. Refer to Appendix D for more information on proper battery disposal.
- Check cable to terminal.
- Wireless units (Bluetooth or 802.11b) only: Establish RF Link. Restore LAN associativity on 802.11b wireless units.
- Invalid label format or command structure — put printer in Communications Diagnostic (Hex Dump) Mode to diagnose problem (refer to Troubleshooting Tests section).

### 7. *Reduced battery life*

- Check battery date code — if battery is one to two years old, short life may be due to normal aging.
- Replace battery. (Always dispose of used batteries properly. Refer to Appendix D for more information on proper battery disposal.)

### 8. *Flashing icon:*

- No application or application corrupted: reload program.
- Flashing indicator is normal while data is being received.

---

**9. Flashing  or  icon :**

- Check that media is loaded.
- Ensure Media Cover is properly closed and latched.

**10. Skips labels (only when using label stock):**

- Check media for top of form sense mark or label gap.
- Check that the maximum print field has not been exceeded on label.
- Ensure bar or gap sensor is not blocked or malfunctioning.

**11. Communication Error:**

- Check media is loaded.
- Ensure Media Cover is properly closed and latched and error indicators are off.
- Check baud rate.
- Replace cable to terminal.

**12. Label Jam:**

- Open media cover.
- Apply generous amount of alcohol to printer in area of jammed label.

**13. Blank LCD Screen**

- No application loaded or application corrupted: reload program.

**14. Magnetic Strip Card or Smart Card Won't Read**

- Ensure the "RDR" text is displayed, indicating card reader is enabled. (Refer to the Operator Controls section.)
- Ensure card is inserted with the magnetic stripe or microchip facing in the correct direction.
- Check card for excessive wear or damage to either the magnetic strip or the microchip.

**15. Battery Pack Is Hard to Insert**

- The battery packs for the RW 420 and QL 420 model printers are similar in size and shape, but not interchangeable. Verify you are using the correct battery pack. The battery pack part number for the RW 420 is CT17102-2 (Re-order part number AK17463-005).
- Verify that the shrink wrapping and the warning card protecting the battery contacts have been removed.

---

## Troubleshooting Techniques

### Printing a Configuration Label

To print out a listing of the printer's current configuration follow these steps:

1. Turn the printer off. Load the media compartment with journal media (media with no black bars printed on the back)
2. Press and hold the Feed Button.
3. Press and release the Power button and keep the Feed button pressed. When printing starts, release the Feed button.

Refer to Figures 23 through 23b for a sample configuration printout.

### Performing a Forced Shutdown

If the printer has locked up and is not responding to any operator inputs or external commands, from either a connected terminal or a linked LAN, you can perform a forced shutdown.

- If the printer software locks up during normal operation, force the printer to shut down by pressing and holding the Power Button for 3 seconds.
- If you try to turn the printer off normally and the software locks up, the printer will automatically shut itself off after a 10 second delay.
- If you try to turn the printer off and it does not respond, you can force an immediate shut down by pressing and holding the Power Button again within 10 seconds.

A forced shutdown will preserve the printer's data and settings

### Communications Diagnostics

If there's a problem transferring data between the computer and the printer, try putting the printer in the Communications Diagnostics Mode (also referred to as the "DUMP" mode). The printer will print the ASCII characters and their and their text representation (or the period '.', if not a printable character) for any data received from the host computer

To enter Communications Diagnostics Mode:

1. Print a configuration label as described above.
2. At the end of 2nd diagnostics report, the printer will print:  
"Press FEED key to enter DUMP mode."

- 
3. Press the FEED key. The printer will print: "Entering DUMP mode."



*NOTE: If the FEED key is not pressed within 3 seconds, the printer will print "DUMP mode not entered" and will resume normal operation.*

4. At this point, the printer is in DUMP mode and will print the ASCII hex codes of any data sent to it, and their text representation (or "." if not a printable character).

Additionally, a file with a ".dmp" extension containing the ASCII information will be created and stored in the printer's memory. It can be viewed, "cloned" or deleted using the Label Vista application. (Refer the Label Vista documentation for more information.)

To terminate the Communications Diagnostics Mode and return the printer to normal operations:

1. Turn the printer OFF.
2. Wait 5 seconds.
3. Turn the printer ON.

### **Calling Technical Support**

If the printer fails to print the configuration label, or you encounter problems not covered in the Troubleshooting Guide, contact Zebra Technical Support. Technical Support addresses and phone numbers for your area can be found in Appendix D of this manual. You will need to supply the following information:

- Model number/type (e.g. RW 420)
- Unit serial number (14 digit number, including dashes)  
The serial number is found on the large label on the back of the printer. It is also reported in the configuration label printout. (Refer to Figures 23 through 23b.)
- Product Configuration Code (PCC) (15 digit number, including dashes). The PCC number for an RW 420 Printer will begin with "RW4" and is printed above the unit serial number on the back of the unit.





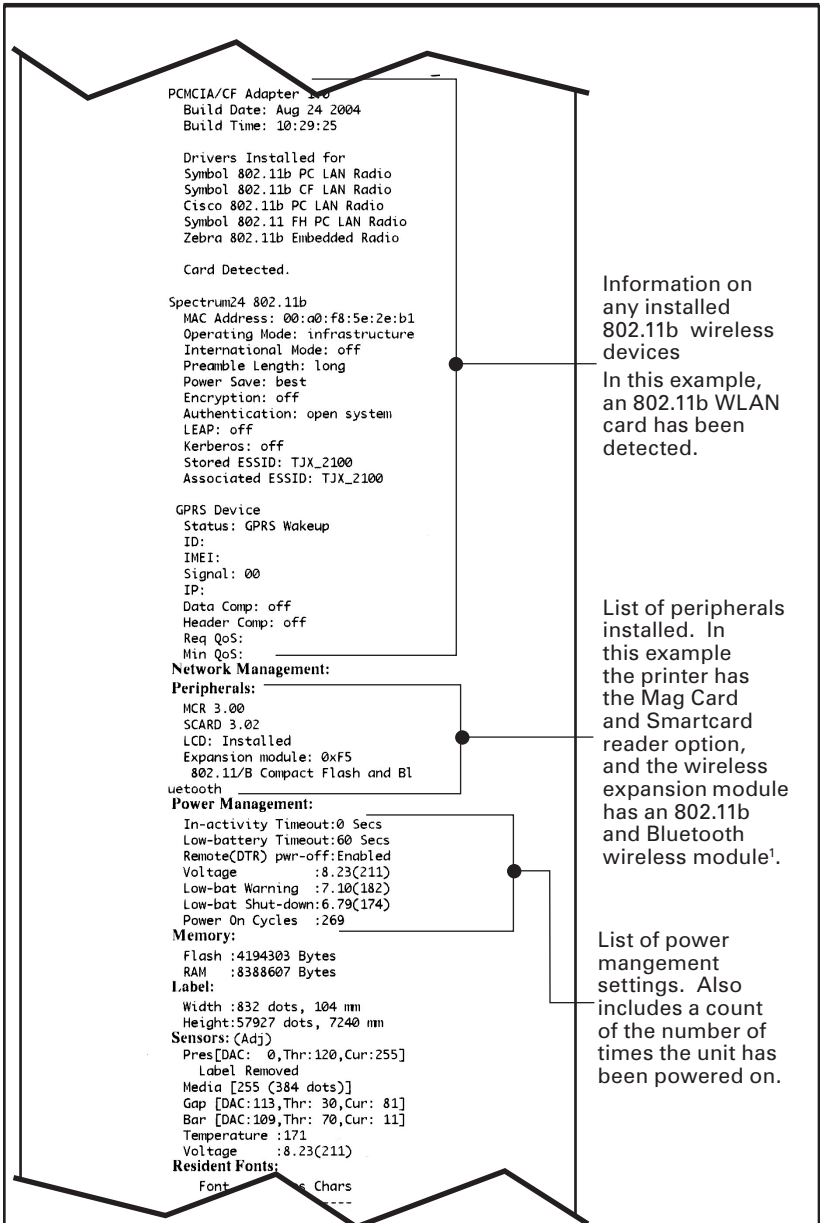

<sup>1</sup>. Dual radio units as illustrated above are not yet offered for sale. This option will be offered after initial product release.

**Figure 23a: Configuration Label Example (continued)**

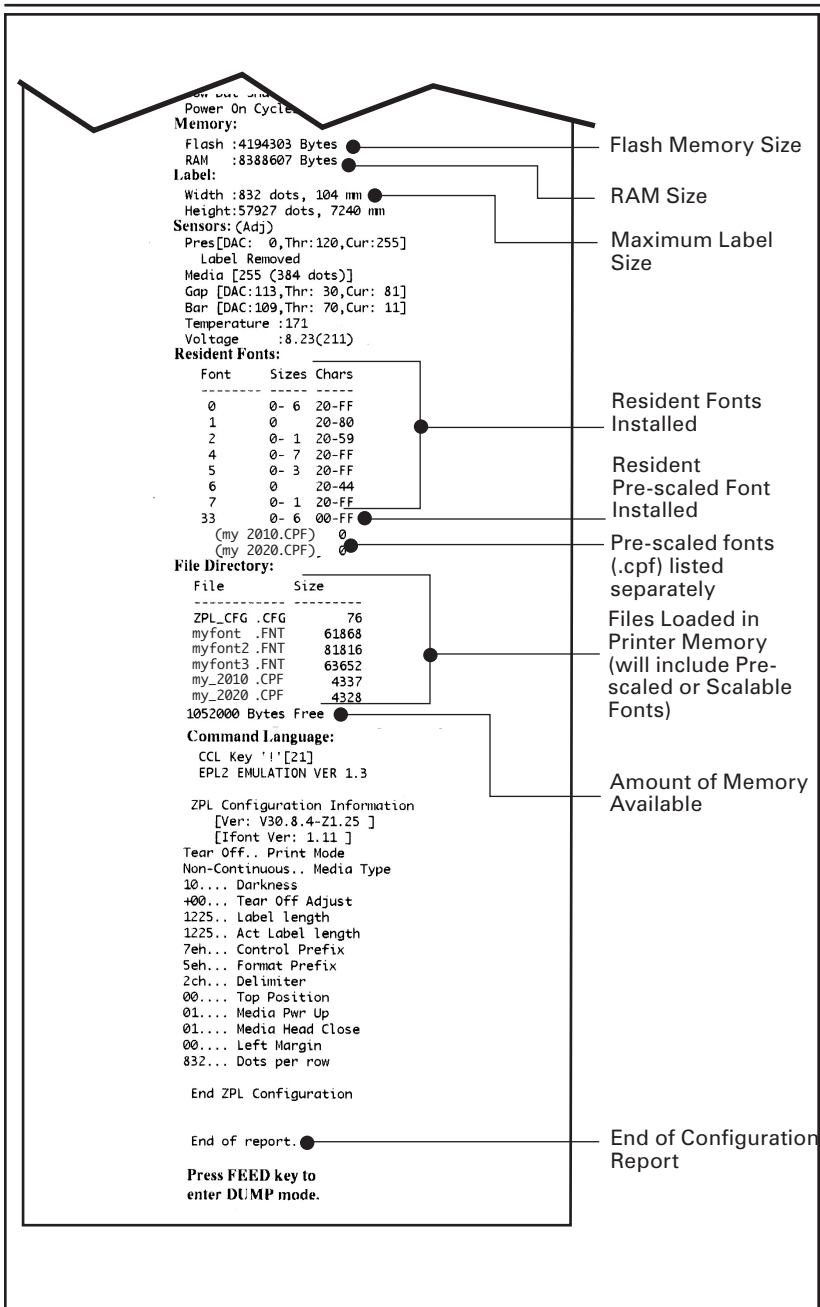

Figure 23b: Configuration Label Example (continued)

# Specifications

---



*NOTE.- Printer specifications are subject to change without notice.*

## Printing Specifications

Print Width	Up to 4.09 in. (103.8 mm)
Print Speed	3 in. /second 76.2 mm/second)
Distance from Print Element to Tear Edge	.20 in. (5 mm) 41 dots
Print Head Life, calculated	1,964,160 in. (50 Km) nominal
Print Density	203 dots/inch (8 dots/mm)

## Memory/Communications Specifications

Flash Memory	4 MB flash (standard)
RAM Memory	8 MB RAM (standard)
Standard Communications	RS-232C serial port (RJ-45 connector) Configurable Baud rate (from 9600 to 57.6 Kbps), parity and data bits. Software (X-ON/X-OFF) or hardware (DTR/STR) communication handshake protocols.  USB 2.0 Full Speed Interface (12 Mbps))
Optional Wireless Communications	Bluetooth compatible 2.4 GHz SRRF link  Wireless LAN capabilities comply with 802.11b protocols

## Communications Ports

### USB

Pin#	Signal Name	Type	Description
1	VBUS	-	USB Bus Power
2	USB -	bi-directional	I/O signals
3	USB +	bi-directional	I/O signals
4	USB_ID	-	Identifies A/B connector
5	Return	-	Ground

### RS232

Pin#	Signal Name	Type	Description
1	NC	no connect	
2	NC	no connect	
3	RXD	input	Receive Data
4	TXD	output	Transmit Data
5	DTR	output	Data Terminal Ready set high when printer is on.
6	GND		Ground
7	DSR	input	Data Set Ready low to high transition turns printer on, high to low transi- tion turns printer off (if en- abled)
8	RTS	output	Request To Send set high when printer is ready to accept a command or data
9	CTS	input	Clear To Send from host
10	NC	no connect	

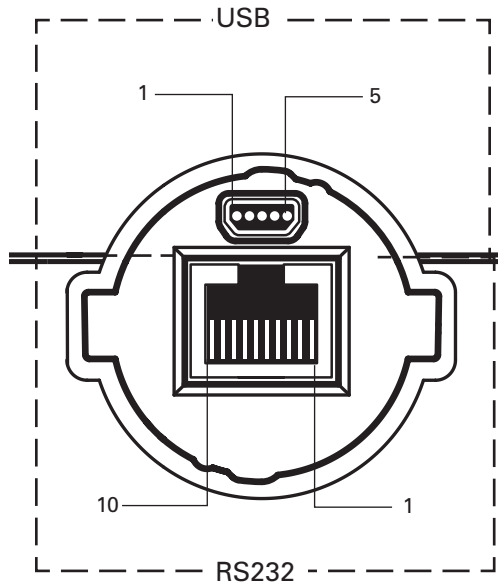

**Figure 24: Communication Ports**

## Media Specifications

Media Width	2.0 in. to 4.1 in. (50.8 to 104.1 mm)
Max. continuous receipt (w/std. memory)	143 in. (3620 mm)
Inter-label Gap.	0.08 in. to 0.16 in. (0.12 in. preferred) (2 mm to 4 mm [3 mm preferred])
Label Thickness	.0025" to .0065" (.064 mm to .165 mm)
Max. Label Roll dia.	2.25 in. (57 mm) O.D.
Label Inner Core	.75 in. (19 mm) minimum dia; 1.38 in. (35 mm) optional setting
Black Mark Dimensions	The reflective media black marks should extend past the centerline of the roll.
Media Requirements	Minimum mark width: 0.5" (12.7mm) perpendicular to edge of media, centered within the width of the roll. Mark length: 0.094" (2.4 mm) parallel to edge of media

Use Zebra brand direct thermal media that is outside wound. Media may be reflective (black mark) sensing, or transmissive (gap) sensing, die-cut, or continuous. RW 420 configured with the External Media option will accept fanfold media used with an external media supply.

For die-cut labels, use only full auto dies.

## Font/Bar Code Specifications

<p>Fonts Available</p>	<p>Standard Fonts: 25 bit-mapped fonts; 1 scalable font (CG Trimvirate Bold Condensed*)  Downloadable optional bit-mapped &amp; scalable fonts via Label Vista software.  Optional International character sets:  Chinese 16 x 16 (trad), 16 x 16 (simplified), 24 x 24 (simplified); Japanese 16 x 16, 24 x 24; Hebrew/Arabic  *contains UFST from Agfa Monotype Corporation</p>
<p>Linear Bar Codes Available</p>	<p>Codabar  UCC/EAN 128  UCC-128 Composite A/B/C  Code 39  Code 93  EAN 8/JAN 8, 2 and 5 digit extensions  EAN-8 Composite  EAN 13/JAN 13, 2 and 5 digit extensions  EAN-13 Composite  Interleaved 2 of 5  MSI/Plessey  FIM/POSTNET  UPC-A, 2 and 5 digit extensions  UPCA Composite  UPC E, 2 and 5 digit extensions  UPCE Composite</p>
<p>2-D Bar Codes Available</p>	<p>MaxiCode  PDF 417  Datamatrix (using ZPL emulation)  RSS: RSS-14 Truncated  RSS-14 Stacked  RSS-14 Stacked Omnidirectional  RSS Limited  RSS Expanded</p>
<p>Rotation Angles</p>	<p>0°, 90°, 180°, and 270°</p>

## Physical/Environmental/Electrical Specifications

Weight w/ battery, excluding media*	2.0 lbs. (.91 kg. )
Temperature	Operating: -4° to 131° F (-20° to 55° C) Storage: -22° to 149° F (-30° to 65° C) Range
Relative Humidity	Operating: 10% to 90% (non-condensing) Storage: 10% to 90% (non-condensing)
Battery	7.4V Lithium-Ion 4 AHr.
Chargers:	External single battery charger Model LI72 120-230 VAC depending on model selected External 4-bay charger Model UCLI72-4 100-240 VAC RW 420 Cradle/Charger 12-48 VDC input Model RCLI-DC Mobile Chargers DC-DC run/charge units Input voltages: 12VDC, 9-30 VDC ,30-60 VDC

\* Weight is for unit without MCR or SmartCard options



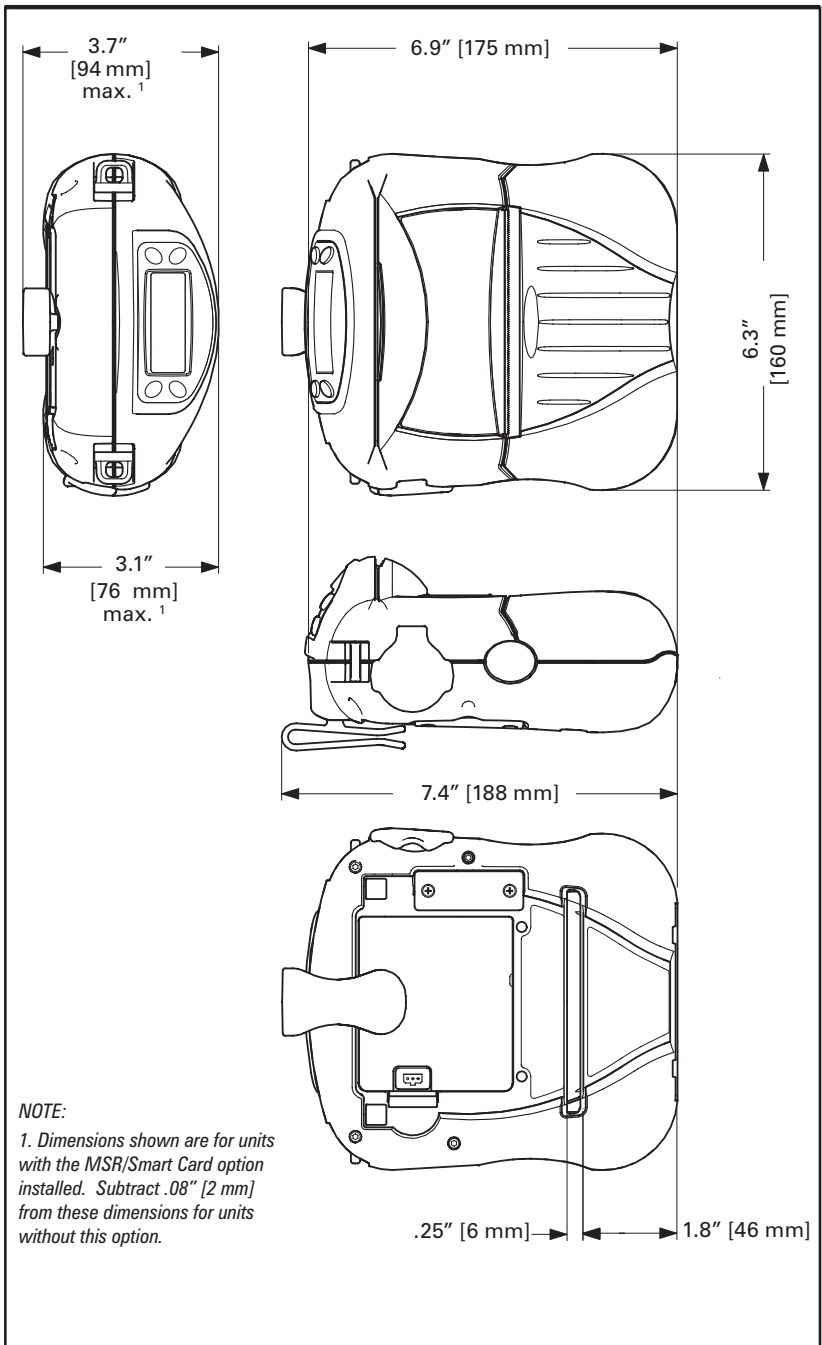

**Figure 25: RW 420 Overall Dimensions**

## RW 420 Accessories

Description	Order Number	Input Voltage
Adjustable shoulder strap	BT11132-1	n/a
Carrying Strap	BT16899-1	n/a
Protective Soft Case	AK17463-001	n/a
Extra Battery Pack	AK17463-005	n/a
RW 420 Vehicle Cradle/Charger	AK17463-004	9-30 VDC
RW 420 Vehicle Cradle/Charger w/ cigarette lighter adapter	AK17463-003	9-30 VDC
Model RCLI-DC Mobile Chargers DC-DC run/charge units	CC16614-1 CC16614-2 CC16614-3 CC16614-9 <sup>2</sup>	12 VDC 9-30 VDC 30-60 VDC 12 VDC
Model RCLI-AC Mobile Charger AC/DC run/charge unit	CC16614-4	100-240 VAC 50/60 Hz
Model LI 72- Single Battery Charger	AT15759-tab <sup>1</sup>	100-240 VAC 50/60 Hz
Model UCLI72-4-Four Battery Charger (U.S./ Japan)	AT16305-1	100-240 VAC 50/60 Hz
Model UCLI72-4-Four Battery Charger (U.K.)	AC16305-1	100-240 VAC 50/60 Hz
Model UCLI72-4-Four Battery Charger (Euro)	AC16305-2	100-240 VAC 50/60 Hz
Model UCLI72-4-Four Battery Charger (Australia)	AC16305-3	100-240 VAC 50/60 Hz

### NOTES

1. Part number of LI72 Single Battery Chargers will vary depending upon the intended country of use. Contact the factory or your Zebra re-seller for complete part number information.

2. CC16614-9 is the **cigarette lighter adapter version of CC16614-1**.

Refer to Appendix A for information on Data I/O Cables.

For more details on available accessories, contact your authorized Zebra re-seller.

# Appendix A

## Interface Cables

### RS232 Download Cable

Part Number BL17205-1; RW Mod Plug to 9-Pin DB PC Cable

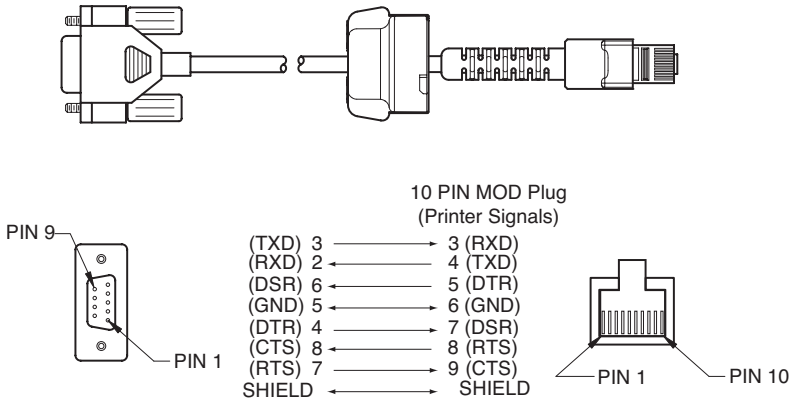

### USB Cable

Part Number AT17010-1; USB A to USB Mini B Cable

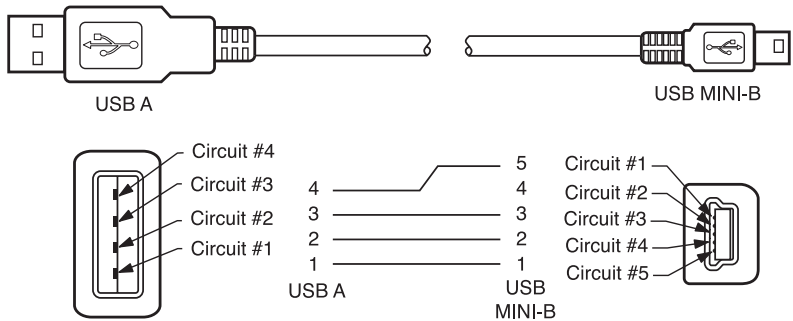

# Appendix A

## MORE INTERFACE CABLES

Terminal	Cable Part Number	Cord Lgth/Type	Terminal Connector	Printer Connector	Notes
<b>SYMBOL</b> 8000	CL17219-1	8' /Coiled	Symbol 8000 Series proprietary	MOD 10/w twist lock	
<b>INTERMEC</b> 700 CK30	BL17216-1 BL17218-1	8' Coiled 8' coiled	16 pin Hirose 26 pin JAE	MOD10/w twist lock MOD 10/w twist lock	
<b>COMPSEE</b> Apex II, III, IV	CL17202-3	8' Coiled	MOD 10	MOD10/w twist lock	
<b>MISCELLANEOUS</b> DEX	BL17204-1	16"/ straight	1/4" phone jack/DEX	MOD 10/w twist lock	

## **Appendix B**

---

### **Media Supplies**

To insure maximum printer life and consistent print quality and performance for your individual application, it is recommended that only media produced by Zebra be used. Advantages include:

- Consistent quality and reliability of media products.
- Large range of stocked and standard formats.
- In-house custom format design service.
- Large production capacity which services the needs of many large and small media consumers including major retail chains world wide.
- Media products that meet or exceed industry standards.

For more information call Zebra Technologies Corporation at +1.866.230.9495 (U.S., Canada and Mexico) and ask to speak to a Media Sales Representative.

## **Appendix C**

---

### **Maintenance Supplies**

In addition to using quality media provided by Zebra, it is recommended that the printer be cleaned as prescribed in the maintenance section. The following items are available for this purpose:

- Cleaning Pen (10 pack), Reorder No. AN11209-1
- Cleaning Kit with Cleaning Pen, and Cotton Swabs, Reorder No. AT702-1

# Appendix D

---

## Product Support

When calling with a specific problem regarding your printer, please have the following information on hand:

- Model number/type (e.g. RW 420)
- Unit serial number
- Product Configuration Code (PCC)-15 digit number starting with "RW4"

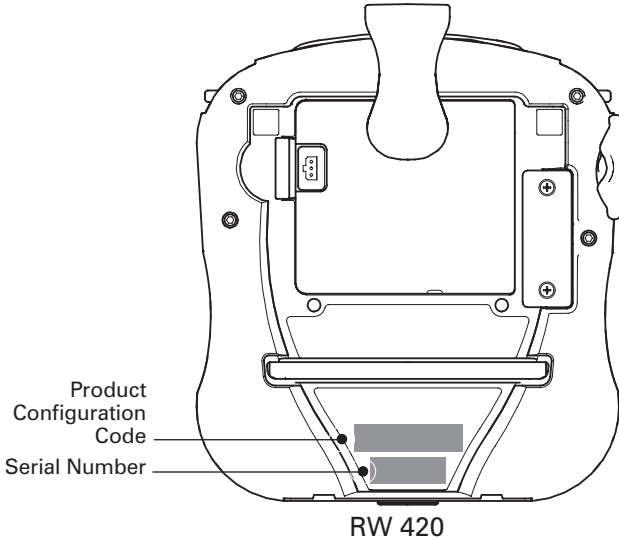

For product support, contact Zebra Technologies at:  
[www.zebra.com](http://www.zebra.com)

### **Zebra Technologies International, LLC**

333 Corporate Woods Parkway  
Vernon Hills, Illinois 60061-3109 USA  
Phone: +1.847.793.2600 or  
+1.800.423. 0422  
Fax: +1.847.913.8766

### **Zebra Technologies Europe Limited**

Zebra House  
The Valley Centre, Gordon Road  
High Wycombe  
Buckinghamshire HP13 6EQ, UK  
Phone: +44.1494.472872  
Fax: +44.1494.450103

### **Zebra Technologies**

Latin American Sales Office  
9800 NW 41Street  
Suite 220  
Doral, Florida 33178 USA  
Phone: +1.305.558.8470  
Fax: +1.305.558.8485

### **Zebra Technologies Asia Pacific, LLC**

16 New Industrial Road  
#05-03 Hudson TechnoCentre  
Singapore 536204  
Phone: +65-6858 0722  
Fax: +65-6885 0838

## Appendix D

---

### Battery Disposal



The EPA certified RBRC® Battery Recycling Seal on the Lithium-Ion (Li-Ion) battery supplied with your printer indicates Zebra Technologies Corporation is voluntarily participating in an industry program to collect and recycle these batteries at the end of their useful life, when taken out of service in the United States or Canada. The RBRC® program provides a convenient alternative to placing used Li-Ion batteries into the trash or the municipal waste stream, which may be illegal in your area.



*When the battery is worn out, insulate the terminals with tape before disposal*

Please call 1-800-8-BATTERY for information on Li-Ion battery recycling and disposal bans/restrictions in your area. Zebra Technologies Corporation's involvement in this program is part of our commitment to preserving our environment and conserving our natural resources.

Outside North America, please follow local battery recycling guidelines.

### Product Disposal



Do not dispose of this product in unsorted municipal waste. This product is recyclable. Please recycle according to your local standards. For more information, please see our web site at: <http://www.zebra.com/recycle>

# Appendix E

## Web Links

The following details the URLs for finding specific documents on Zebra's Web site [www.zebra.com](http://www.zebra.com).

Programming Manuals URL: EPL, ZPL & CPCL Language Manuals

[http://www.zebra.com/id/zebra/na/en/index/resource\\_library/manuals.results.html](http://www.zebra.com/id/zebra/na/en/index/resource_library/manuals.results.html)

Printing Solutions for Business Improvement

Home | Login | Create Profile | Contact Zebra

Select Language [v] Find it Now [v]

INDUSTRY SOLUTIONS PRODUCTS HOW TO BUY DRIVERS & DOWNLOADS SERVICE & SUPPORT RESOURCE LIBRARY ABOUT ZEBRA FOR PARTNERS

GETTING STARTED Home > Resource Library > Manuals

FREQUENTLY ASKED QUESTIONS

MANUALS

GLOSSARIES

WHITE PAPERS

CASE STUDIES

ROI CALCULATORS

Manuals

To find a user guide or user manual for your Zebra printer model (e.g. RW 420)

Printer Maintenance Manuals are available through your reseller. Find a reseller.

Printer Model: RW420

Manual Type: Programming Guide

Language: Show All

SUBMIT

Select printer model (e.g. RW 420)

Select "Programming Guide"

Select "Show All"

Click on "Submit"

Need information about Zebra Card printers? Visit [www.zebra.com](http://www.zebra.com).

© 2005 ZIH Corp. All rights reserved. Copyright | Terms & Conditions | Privacy Statement | Contact Zebra | Site Help | Site Map

Wireless Configuration Quick Start Guide URL:

[http://www.zebra.com/id/zebra/na/en/index/resource\\_library/manuals.results.html](http://www.zebra.com/id/zebra/na/en/index/resource_library/manuals.results.html)

Printing Solutions for Business Improvement

Home | Login | Create Profile | Contact Zebra

Select Language [v] Find it Now [v]

INDUSTRY SOLUTIONS PRODUCTS HOW TO BUY DRIVERS & DOWNLOADS SERVICE & SUPPORT RESOURCE LIBRARY ABOUT ZEBRA FOR PARTNERS

GETTING STARTED Home > Resource Library > Manuals

FREQUENTLY ASKED QUESTIONS

MANUALS

GLOSSARIES

WHITE PAPERS

CASE STUDIES

ROI CALCULATORS

Manuals

To find a user guide or user manual for your Zebra printer, start your search by selecting your printer model (e.g. RW 420)

Printer Maintenance Manuals are available through your reseller. Find a reseller.

Printer Model: RW420

Manual Type: Connectivity Guide

Language: Show All

SUBMIT

Select printer model (e.g. RW 420)

Select "Connectivity Guide"

Select "Show All"

Click on "Submit"

Need information about Zebra Card printers? Visit [www.zebra.com](http://www.zebra.com).

© 2005 ZIH Corp. All rights reserved. Copyright | Terms & Conditions | Privacy Statement | Contact Zebra | Site Help | Site Map

continued



Label Vista Download URL:

[http://www.zebra.com/id/zebra/na/en/index/drivers\\_downloads/utilities.html](http://www.zebra.com/id/zebra/na/en/index/drivers_downloads/utilities.html)

At the resulting window select "Label Vista" (circled)

Printing Solutions for Business Improvement

Home | Login | Create Profile | Contact Zebra

Select Language

Search

Find It Now

INDUSTRY SOLUTIONS | PRODUCTS | HOW TO BUY | DRIVERS & DOWNLOADS | SERVICE & SUPPORT | RESOURCE LIBRARY | ABOUT ZEBRA | FOR PARTNERS

DRIVERS

UTILITIES

Mobile Utilities

OTHER UTILITIES

Home > Drivers & Downloads > Utilities

### Utilities

Zebra utilities provide powerful added value to your Zebra bar code printers. Take advantage of enhanced printing, conversion, and administration capabilities; message management; and much more.

**Find Utilities for Your Printer**

Select printer model

SUBMIT

**Can't find your printer model?**

- > Contact technical support for utilities for older model printers.

**Mobile Utilities**

- > Tools with intelligent connection and control for your Zebra mobile bar code printers.
- > Bluetooth Zebra Portable Radio
- > TR 220 Software Development Kit
- > PS 2100 Software Development Kit
- > **Label Vista**

**Other Utilities**

- > Maximize Zebra bar code printer flexibility, networking, management, and more with useful Zebra utilities.
- > Convert.zip
- > EPL Firmware Downloader
- > EPL Font Downloader
- > HASP.exe (Create-A-Label v3.04 for XP)
- > Line Mode Configure Utility – Parallel
- > Line Mode Configure Utility – Serial
- > Z Tools
- > SetWLAN

RELATED RESOURCES

- > Find software compatible with your printer.

PRINTER MANAGEMENT

- > ZebraNet® Printer Management Products
- > ZebraLink™
- > Zebra Print Server MIB

Need information about Zebra Card printers? > www.z

© 2005 ZIH Corp. All rights reserved. Copyright | Terms & Conditions

Click on "Label Vista" and then on "Download demo" in the next screen to download the application.

# Index

---

## A

- Accessories
  - Adjustable Shoulder Strap 37
  - Belt Clip 36
  - Docking Station
    - installing the printer in 38
    - removing the printer from 40
  - list of 58

## B

- Battery pack
  - charging 11
    - while printing 12
  - disposal of 41,44
  - installing 11
  - life, tips for extending 41
- Bluetooth Device Address (BDA) 25
- Bluetooth Networking Overview 25

## C

- Card Readers
  - Magnetic Stripe Reader 33
  - Smart Card Reader 35
- Charger, Battery
  - LI 72 (single charger) 11
  - UCL172-4 (quad charger) 12
    - charging cycle times 13
    - safety 12

## Cleaning

- exterior 42
- interior 42
- platen 42
- printhead 42
- tear bar 42

## Communications

- RS232 23
  - Connector signals 52
- USB 24

## Configuration Code, product (PCC) 47

- Controls, Operator 18
  - functions illustrated 19
  - LCD functions, extended 20
- Cradle 20,38

## D

- Declaration of Conformity
  - 802.11b (Compact Flash radio)
    - EU countries 29,31
  - Bluetooth radio (ZBR-3)
    - EU Countries 26
  - Zebra 802.11b Radio 31

## L

- Label, Configuration
  - printing 22

- Label, configuration, example 48
- Label Vista 27,32

## M

- Manual
  - CPCL Programming 27,32
  - EPL Programming 32
  - ZPL II Programming 32
- Media, loading 14
  - fan-fold media 16
    - media Spacer, use of 16

## P

- Programming language
  - EPL 32
  - ZPL II 32

## R

- Radio Regulatory Information
  - 802.11b (Compact Flash radio)
    - EU countries 28,30
  - Bluetooth radio (ZBR-3)
    - EU countries 26
  - Zebra 802.11b Radio Module 30
    - EU Countries 30

## S

- Software 32
- Specifications
  - Font/bar Codes 55
  - Label 54
  - Memory/communications 51
  - Physical 56
  - printing 51

## T

- Technical Support
  - contacting 47
- Troubleshooting
  - control panel indicators 43
  - entering communications diagnostic mode communicate 46
  - forced shutdown 46
  - printing a configuration label 46
  - topics 44

## W

- Wireless Communications
  - 802.11b (Compact Flash radio) 28,30
    - using in a WLAN 27
  - Bluetooth (ZBR3) radio 25
  - Zebra 802.11b Radio Module 30

# Patent Numbers

This product and/or its use may be covered by one or more of the following US patents and corresponding international patents worldwide

D275,286	5,047,617	5,372,439	5,570,123	6,068,415
D347,021	5,103,461	5,373,148	5,578,810	6,095,704
D389,178	5,113,445	5,378,882	5,589,680	6,109,801
D430,199	5,140,144	5,396,053	5,612,531	6,123,471
D433,702	5,132,709	5,396,055	5,642,666	6,147,767
3,964,673	5,142,550	5,399,846	5,657,066	6,151,037
4,019,676	5,149,950	5,408,081	5,768,991	6,201,255 B1
4,044,946	5,157,687	5,410,139	5,790,162	6,231,253 B1
4,360,798	5,168,148	5,410,140	5,791,796	6,261,009
4,369,361	5,168,149	5,412,198	5,806,993	6,261,013
4,387,297	5,180,904	5,415,482	5,813,343	6,267,521
4,460,120	5,229,591	5,418,812	5,816,718	6,270,072 B1
4,496,831	5,230,088	5,420,411	5,820,279	6,285,845 B1
4,593,186	5,235,167	5,436,440	5,848,848	6,292,595
4,607,156	5,243,655	5,444,231	5,860,753	6,296,032
4,673,805	5,247,162	5,449,891	5,872,585	6,364,550
4,736,095	5,250,791	5,449,893	5,874,980	6,379,058 B1
4,758,717	5,250,792	5,468,949	5,909,233	6,409,401 B1
4,816,660	5,262,627	5,479,000	5,976,720	6,411,397 B1
4,845,350	5,267,800	5,479,002	5,978,004	6,428,227 B2
4,896,026	5,280,163	5,479,441	5,995,128	6,530,705
4,897,532	5,280,164	5,486,057	5,997,193	6,540,122
4,923,281	5,280,498	5,503,483	6,004,053	6,607,316
4,933,538	5,304,786	5,504,322	6,010,257	6,609,844
4,992,717	5,304,788	5,528,621	6,020,906	6,874,958
5,015,833	5,321,246	5,532,469	6,034,708	6,899,477
5,017,765	5,335,170	5,543,610	6,036,383	
5,021,641	5,364,133	5,545,889	6,057,870	
5,029,183	5,367,151	5,552,592	6,068,415	



[www.zebra.com](http://www.zebra.com)

---

**Zebra Technologies International, LLC**

333 Corporate Woods Parkway  
Vernon Hills, Illinois 60061.3109 USA

Phone: +1.847.634.6700

Toll-Free: +1.800.423.0422

Fax: +1.847.913.8766