

ZEBRA TECHNOLOGIES CORP

BLUETOOTH RADIO MODULE

Model: ZBR4QL

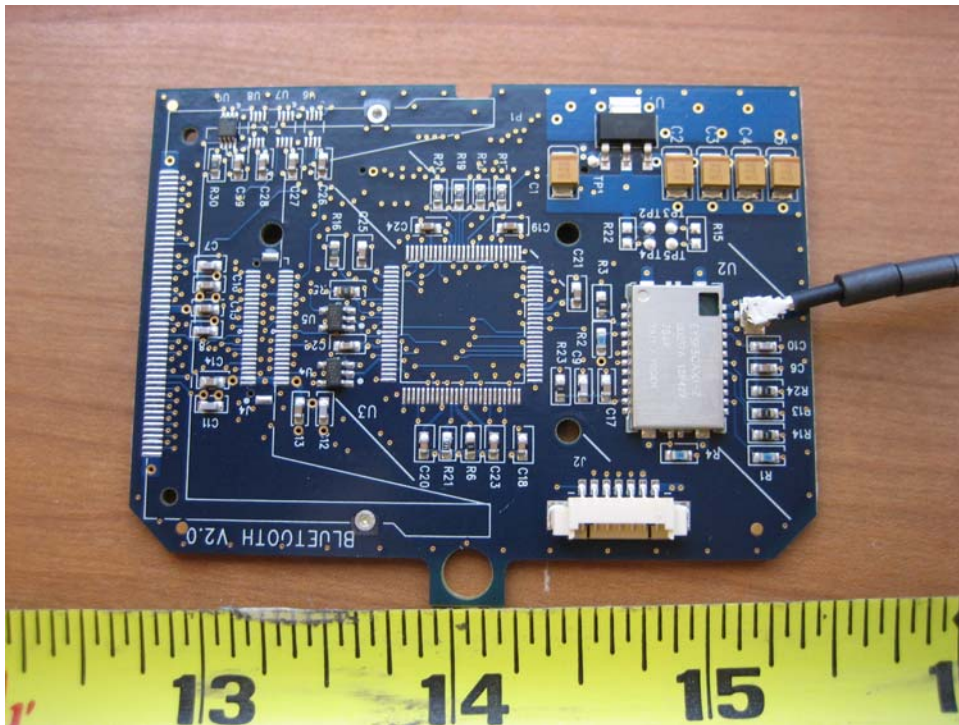

29 July 2008

Report No.: SL08060906-ZBR-037-QL(15.247)(ZBR4QL)
(This report supersedes NONE)



Modifications made to the product : None

This Test Report is Issued Under the Authority of:

	
Choon Sian Ooi Test Engineer	Leslie Bai Engineering Reviewer

This test report may be reproduced in full only.
Test result presented in this test report is applicable to the representative sample only.

EMC Test Report
To: FCC Part 15.247

SIEMIC, INC.
Assessing global markets



SIEMIC ACREDITATION DETAILS: NVLAP Lab Code: 200729-0

United States Department of Commerce
National Institute of Standards and Technology

NVLAP[®]

Certificate of Accreditation to ISO/IEC 17025:2005

NVLAP LAB CODE: 200729-0

SIEMIC Laboratories
San Jose, CA

*is accredited by the National Voluntary Laboratory Accreditation Program for specific services,
listed on the Scope of Accreditation, for:*

ELECTROMAGNETIC COMPATIBILITY AND TELECOMMUNICATIONS

*This laboratory is accredited in accordance with the recognized International Standard ISO/IEC 17025:2005.
This accreditation demonstrates technical competence for a defined scope and the operation of a laboratory quality
management system (refer to joint ISO-ILAC-IAF Communique dated 18 June 2005).*

2008-01-01 through 2008-12-31
Effective dates



Sally J. Bruce
For the National Institute of Standards and Technology

SIEMIC ACREDITATION DETAILS: FCC Registration No. 783147

FEDERAL COMMUNICATIONS COMMISSION

Laboratory Division
7435 Oakland Mills Road
Columbia, MD 21046

December 20, 2007

Registration Number: 783147

SIEMIC Laboratories
2206 Ringwood Avenue,
San Jose, CA 95131

Attention: Leslie Bai

Re: Measurement facility located at San Jose
3 & 10 meter site
Date of Renewal: December 20, 2007

Dear Sir or Madam:

Your request for renewal of the registration of the subject measurement facility has been received. The information submitted has been placed in your file and the registration has been renewed. The name of your organization will remain on the list of facilities whose measurement data will be accepted in conjunction with applications for Certification under Parts 15 or 18 of the Commission's Rules. Please note that the file must be updated for any changes made to the facility and the registration must be renewed at least every three years.

Measurement facilities that have indicated that they are available to the public to perform measurement services on a fee basis may be found on the FCC website www.fcc.gov under E-Filing, OET Equipment Authorization Electronic Filing, Test Firms.

Sincerely,

Phyllis Parrish
Industry Analyst

SIEMIC ACREDITATION DETAILS: Industry of Canada Registration No. 4842-1



May 23rd, 2008

OUR FILE: 46405-4842
Submission No: 126429

Siemic Inc.
2205 Ringwood Ave.
San Jose CA 95131
USA

Attention: Leslie Bai

Dear Sir/Madame:

The Bureau has received your application for the registration / renewal of 3/10m OATS. Be advised that the information received was satisfactory to Industry Canada. The following number(s) is now associated to the site(s) for which registration / renewal was sought (**4842A-1**). Please reference the appropriate site number in the body of test reports containing measurements performed on the site. In addition, please be informed that the Bureau is now utilizing a **new site numbering scheme** in order to simplify the electronic filing process. Our goal is to reduce the number of secondary codes associated to one particular company. The following changes have been made to your record.

- Your primary code is: **4842**
- The company number associated to the site(s) located at the above address is: **4842A**
- The table below is a summary of the changes made to the unique site registration number(s):

New Site Number	Obsolete Site Number	Description of Site	Expiry Date (YYYY-MM-DD)
4842A-1	4842-1	5m Chamber	2010-05-23

Furthermore, to obtain or renew a unique site number, the applicant shall demonstrate that the site has been accredited to ANSI C63.4-2003 or later. A scope of accreditation indicating the recognition by a recognized accreditation body to ANSI C63.4-2003 shall be accepted. Please indicate in a letter the previous assigned site number if applicable and the type of site (example: 3 meter OATS or 3 meter chamber). If the test facility is not accredited to ANSI C63.4-2003 or later, the test facility shall submit test data demonstrating full compliance with the ANSI standard. The Bureau will evaluate the filing to determine if recognition shall be granted.

The frequency for re-validation of the test site and the information that is required to be filed or retained by the testing party shall comply with the requirements established by the accrediting organization. However, in all cases, test site re-validation shall occur on an interval not to exceed two years. There is no fee or form associated with an OATS filing. OATS submissions are encouraged to be submitted electronically to the Bureau using the following URL: http://strategis.ic.gc.ca/epic/ipic/intermet/inceb-Mst.nsf/ewh_000052c.html.

If you have any questions, you may contact the Bureau by e-mail at verification.bureau@ic.gc.ca. Please reference our file and submission number above for all correspondence.

Yours sincerely,



S. Proulx
Test & Measurement Specialist
Certification and Engineering Bureau
1700 Carling Ave. Building 34
Ottawa, Ontario K2H 8S2



SIEMIC, Inc.
Accessing global markets

Title: RF Test Report of Zebra Technologies Corp. model : ZBR4QL
To: FCC 15.247 2008

Serial# SL08060906-ZBR-037-QL(15.247)(ZBR4QL)
Issue Date 29 July 2008
Page 5 of 64
www.siemec.com

SIEMIC ACREDITATION DETAILS: Japan VCCI Registration No. 2195



Voluntary Control Council for Interference
by Information Technology Equipment
7F NOA Bldg. 2-3-5, Azabudai,
Minato-Ku, Tokyo, Japan. 106-0041
Tel:+81-3-5575-3138
Fax:+81-3-5575-3137
<http://www.vccij.or.jp>

February 12, 2004

TO: SIEMIC, INC.

Membership NO: 2195

We confirmed your payment for annual membership fee and admission fee. Thank you very much for your remitting.

Please find enclosed VCCI documents. As admission fee and annual membership fee were confirmed, your company registered as VCCI official member.

From now on, it is possible for your company to submit conformity verification report or/and application for registration of measurement facilities.

Please find necessary forms for your submission from VCCI web-site.
www.vccij.or.jp

When you submit conformity verification report, please submit to Ms. Yoko Inagaki / inagaki@vccij.or.jp and application for registration of measurement facilities, please submit to Mr. Masaru Denda / denda@vccij.or.jp

Their address, phone and fax number are absolutely same as L. Please refer address indicated on top right-hand corner of this page.

If you have any other questions regarding membership, feel free to contact me. Thank you very much.

Best Regards,

Naoko Hori (Ms.)
VCCI
hori@vccij.or.jp

Enclosure

SIEMIC ACREDITATION DETAILS: Japan RF Technologies Accreditation No. MRF050927





SIEMIC ACREDITATION DETAILS: Korea MIC Lab Code: KR0032

시험기관지정서
Certificate
of Designated Testing Laboratory

지정번호(No.) : KR0032

시험기관명 : (주)현대교정인증기술원
(Name of Lab.) (Hyundai Calibration & Certification Technologies Co., Ltd)

주 소 : 경기도 이천시 부발읍 아미리 산136-1
(Address) (136-1, Ami-ri, Bubal-eup, Icheon-si, Kyunggi-Do, Korea)
2206 Ringwood Avenue San Jose, CA, USA.

시험분야 및 범위 : 유선(Telecommunication Part)
(Area & Category) 무선(Radio Communication Part)
전자파장해(EMD) : 미국지사 포함
전자파내성(EMS) : 미국지사 포함
전기안전(Safety)
전자파흡수율(SAR)

위 기관을 정보통신기기시험기관지정및관리등에관한규칙에 의해 정보통신기기시험기관으로 지정합니다.
This is to certify that the above mentioned laboratory is designated as the testing laboratory in accordance with the Regulations on Designation of Testing Laboratory for Information and Communication Equipment.

2005년(Year) 7월(Month) 5일(Date)

전파연구소장
Director General of Radio Research Laboratory
Ministry of Information and Communication
Republic of Korea





SIEMIC, Inc.
Accessing global markets

Title: RF Test Report of Zebra Technologies Corp. model : ZBR4QL
To: FCC 15.247 2008

Serial# SL08060906-ZBR-037-OL(15.247)(ZBR4QL)
Issue Date 29 July 2008
Page 8 of 64
www.siemic.com

SIEMIC ACREDITATION DETAILS: Korea CAB ID: US0160



UNITED STATES DEPARTMENT OF COMMERCE
National Institute of Standards and Technology
Gaithersburg, Maryland 20899

April 17, 2006

Mr. Leslie Bai
SIEMIC Laboratories
2206 Ringwood Avenue
San Jose, CA 95131

Dear Mr. Bai:

I am pleased to inform you that your laboratory has been recognized by the Ministry of Information and Communication's Radio Research Laboratory (RRL) under the Asia Pacific Economic Cooperation (APEC) Mutual Recognition Arrangement (MRA). Your laboratory is now designated to act as a Conformity Assessment Body (CAB) under Appendix B, **Phase I** Procedures, of the APEC Tel MRA. The pertinent information about your laboratory's designation is as follows:

CAB Name: **SIEMIC Laboratories**
Identification No.: **US0160**
Scope:

Coverage	Standards	Date of Recognition
Electro Magnetic Interference	1. RRL Notice No. 2005-82: Technical Requirements for Electromagnetic Interference 2. Annex 8(KN-22), RRL Notice No. 2005-131: Conformity Assessment Procedure for Electromagnetic Interference	April 13, 2006
Electro Magnetic Susceptibility	1. RRL Notice No. 2005-130: Technical Requirements for Electromagnetic Susceptibility 2. Annex 1-7(KN-61000-4-2, -4-3, -4-4, -4-5, -4-6, -4-8, -4-11), RRL Notice No. 2005-132: Conformity Assessment Procedure for Electromagnetic Susceptibility	April 13, 2006

You may submit test data to RRL to verify that the equipment to be imported into Korea satisfies the applicable requirements. The designation of your organization will remain in force as long as its accreditation for the designated scope remains valid and comply with the designation requirements.

The names of all recognized CABs will be posted on the NIST website at <http://ts.nist.gov/mra>. If you have any questions please contact Mr. Jugindar (Joe) Dhillon at (301) 975-5521. We appreciate your continued interest in our international conformity assessment activities.

Sincerely,

David F. Alderman
Group Leader, Standards Coordination and Conformity Group

cc: Jugindar Dhillon





SIEMIC, Inc.
Accessing global markets

Title: RF Test Report of Zebra Technologies Corp. model : ZBR4QL
To: FCC 15.247 2008

Serial# SL08060906-ZBR-037-OL(15.247)(ZBR4QL)
Issue Date 29 July 2008
Page 9 of 64
www.siemic.com

SIEMIC ACREDITATION DETAILS: Taiwan BSMI Accreditation No. SL2-IN-E-1130R



UNITED STATES DEPARTMENT OF COMMERCE
National Institute of Standards and Technology
Gaithersburg, Maryland 20885

May 3, 2006

Mr. Leslie Bai
SIEMIC Laboratories
2206 Ringwood Avenue
San Jose, CA 95131

Dear Mr. Bai:

I am pleased to inform you that your laboratory has been recognized by the Chinese Taipei's Bureau of Standards, Metrology, and Inspection (BSMI) under the Asia Pacific Economic Cooperation (APEC) Mutual Recognition Arrangement (MRA). Your laboratory is now designated to act as a Conformity Assessment Body (CAB) under Appendix B, Phase I Procedures, of the APEC Tel MRA. You may submit test data to BSMI to verify that the equipment to be imported into Chinese Taipei satisfies the applicable requirements. The designation of your organization will remain in force as long as its accreditation for the designated scope remains valid and comply with the designation requirements. The pertinent designation information is as follows:

- BSMI number: **SL2-IN-E-1130R** (Must be applied to the test reports)
- U.S. Identification No: **US0160**
- Scope of Designation: **CNS 13438**
- Authorized signatory: **Mr. Leslie Bai**

The names of all recognized CABs will be posted on the NIST website at <http://ts.nist.gov/mra>. If you have any questions, please contact Mr. Dhillon at 301-975-5321. We appreciate your continued interest in our international conformity assessment activities.

Sincerely,

David F. Alderman
Group Leader, Standards Coordination and Conformity Group

cc: Jogindar Dhillon

NIST



SIEMIC, Inc.
Accessing global markets

Title: RF Test Report of Zebra Technologies Corp. model : ZBR4QL
To: FCC 15.247 2008

Serial# SL08060906-ZBR-037-OL(15.247)(ZBR4QL)
Issue Date 29 July 2008
Page 10 of 64
www.siemic.com

SIEMIC ACREDITATION DETAILS: Taiwan NCC CAB ID: US0160



UNITED STATES DEPARTMENT OF COMMERCE
National Institute of Standards and Technology
Gaithersburg, Maryland 20899

August 8, 2006

Mr. Leslie Bai
SIEMIC Laboratories
2206 Ringwood Avenue
San Jose, CA 95131

Dear Mr. Bai:

I am pleased to inform you that SIEMIC Laboratories has been recognized by the Chinese Taipei's National Communications Commission (NCC) under the Asia Pacific Economic Cooperation for Telecommunications and Information, Mutual Recognition Arrangement (APEC Tel MRA). Your laboratory is now designated to act as a Conformity Assessment Body (CAB) under Appendix B, **Phase I** Procedures, of the APEC Tel MRA.

You may submit test data to NCC to verify that the equipment to be imported into Chinese Taipei satisfies their applicable requirements using the following guidelines:

- Your laboratory's assigned 6-digit U.S. identification number is **US0160**. You should reference this number in your correspondence.
- The scope of designation is limited to **LP0002**. Your designation will remain in force as long as your accreditation remains valid for the scope of designation.

If you have any questions please contact Mr. Jogindar Dhillon via email at dhillon@nist.gov or via fax at 301-975-5414. The names of all recognized laboratories will be posted on the NIST website at <http://ts.nist.gov/mra>. We appreciate your continued interest in our international conformity assessment activities.

Sincerely,

David F. Alderman
Group Leader, Standards Coordination and Conformity Group

cc: Jogindar Dhillon

NIST



SIEMIC, Inc.
Accessing global markets

Title: RF Test Report of Zebra Technologies Corp. model : ZBR4QL
To: FCC 15.247 2008

Serial# SL08060906-ZBR-037-OL(15.247)(ZBR4QL)
Issue Date 29 July 2008
Page 11 of 64
www.siemic.com

SIEMIC ACREDITATION DETAILS: Mexico NOM Recognition



CAMARA NACIONAL
DE LA INDUSTRIA
ELECTRONICA, DE
TELECOMUNICACIONES
E INFORMATICA

Laboratorio Valentín V. Rivero

México D.F. a 16 de octubre de 2006.

**LESLIE BAI
DIRECTOR OF CERTIFICATION
SIEMIC LABORATORIES, INC.
ACCESSING GLOBAL MARKETS
P R E S E N T E**

En contestación a su escrito de fecha 5 de septiembre del año en curso, le comento que estamos muy interesados en su intención de firmar un Acuerdo de Reconocimiento Mutuo, para lo cual adjunto a este escrito encontrara el Acuerdo en idioma inglés y español preferido de los cuales le pido sea revisado y en su caso corregido, para que si esta de acuerdo poder firmarlo para mandarlo con las autoridades Mexicanas para su visto bueno y así poder ejercer dicho acuerdo.

Aprovecho este escrito para mencionarle que nuestro intermediario gestor será la empresa Isabel de México, S. A. de C. V., empresa que ha colaborado durante mucho tiempo con nosotros en lo relacionado a la evaluación de la conformidad y que cuenta con amplia experiencia en la gestoría de la certificación de cumplimiento con Normas Oficiales Mexicanas de producto en México.

Me despido de usted enviándole un cordial saludo y esperando sus comentarios al Acuerdo que nos ocupa.

Atentamente:



**Ing. Faustino Bortez González
Gerente Técnico del Laboratorio de
CANIETI.**

Callejón 77
Hidráulico Condésa
06100 México, D.F.
Tel. 5264-0908 con 12 líneas
Fax 5264-0488
www.canieti.org



SIEMIC ACREDITATION DETAILS: Hong Kong OFTA Recognition No. D23/16V



Your Ref 來函編號 : D23/16 V
Our Ref 本局編號 :

Telephone 電話 : (852) 2961 6320
Fax No 圖文傳真 : (852) 2838 5004
E-mail 電郵地址 : 20 July 2005

Mr. Leslie Bai
Director of Certification,
SIEMIC Laboratories
2206 Ringwood Avenue
San Jose, California 95131
USA

Dear Mr. Bai,

Application of Recognised Testing Agency (RTA)

Referring your submission of 28 June 2005 in relation to the application of RTA, I am pleased to inform you that OFTA has appointed SIEMIC Laboratories (SIEMIC) as a Recognised Testing Agency (RTA) :

Please note that, under the Hong Kong Telecommunications Equipment Evaluation and Certification (HKTEC) Scheme, SIEMIC is authorized to conduct evaluation tests on telecommunications equipment against the following HKTA specifications :

Scope of recognition (HKTA Specifications) :

- 1001, 1002, 1004, 1006, 1007, 1008
- 1010, 1015, 1016
- 1022, 1026, 1027, 1029
- 1030, 1031, 1032, 1033, 1034, 1035, 1039
- 1041, 1042, 1043, 1045, 1047, 1048
- 2001

You are requested to refer to and comply with the code of practice and guidelines for RTA as given in the Information Note OFTA I 411 "Recognised Testing Agency (RTA) for Conducting Evaluation Test of Telecommunications Equipment", which can be downloaded from OFTA's homepage at <http://www.ofta.gov.hk/tec/information-notes.html>.

If you have any queries, please do not hesitate to contact me.

Yours sincerely,

(K K Sin)
for Director-General
of Telecommunications

Office of the Telecommunications Authority
29/F Wu Chung House 213 Queen's Road East Wan Chai Hong Kong
電訊管理局
香港灣仔皇后大道東 213 號胡忠大廈 29 字樓

<http://www.ofta.gov.hk>

This page has been left blank intentionally.

CONTENTS

1	EXECUTIVE SUMMARY & EUT INFORMATION	16
2	TECHNICAL DETAILS.....	17
3	MODIFICATION.....	18
4	TEST SUMMARY.....	19
5	MEASUREMENTS, EXAMINATION AND DERIVED RESULTS	20
	ANNEX A. TEST INSTRUMENT & METHOD	56
	ANNEX B EUT AND TEST SETUP PHOTOGRAPHS.....	60
	ANNEX C. TEST SETUP AND SUPPORTING EQUIPMENT.....	60
	ANNEX D USER MANUAL, BLOCK & CIRCUIT DIAGRAM	64

This page has been left blank intentionally.

1 Executive Summary & EUT information

The purpose of this test programme was to demonstrate compliance of the Zebra Technologies Corp, Bluetooth radio Module, model: **ZBR4QL** against the current Stipulated Standards. The Bluetooth radio Module have demonstrated compliance with the FCC 15.247 2008.

EUT Information

EUT Description : The QL Plus Series ZBR4QL module is a Bluetooth 2.0 radio manufactured by Taiyo-Yuden, part number EYSF3CAXI-Z. The Taiyo-Yuden module is based on the Bluetooth Specification, Version 2.0, Which is an international radio standard.

Zebra Technologies will only use the ZBR4QL radio within Zebra products, primarily portable printers. Both the radio and the antenna will be mounted inside the product and will not be user accessible.

Nothing that Zebra does in the external circuitry surrounding the ZBR4QL module will have any affect on either the transmitter or receiver characteristics of the Taiyo-Yuden module. The only affect that Zebra has on the RF performance is the Zebra custom antenna that is used in each printer.

Model No : ZBR4QL with Host Printer(QL220 Plus, QL320 Plus and QL420 Plus)
Serial No : 01
 : 100~240 VAC, 50~60Hz
Input Power : 7.4 VDC , 0.8A
 Power Supply → Model : FW7511/07A
Classification Per Stipulated Test Standard : Spread Spectrum System / Device



2 TECHNICAL DETAILS

Purpose	Compliance testing of Buletooth Radio Module with stipulated standard
Applicant / Client	Zebra Technologies Corp
Manufacturer	Zebra Technologies Corp 333 Corporate Woods Parkway. Vernon Hills, IL 60061
Laboratory performing the tests	SIEMIC Laboratories
Test report reference number	SL08060906-ZBR-037-QL(15.247)(ZBR4QL)
Date EUT received	19 June 2008
Standard applied	47 CFR §15.247 (2008)
Dates of test (from - to)	14 July 2008 - 25 July 2008
No of Units:	5
Equipment Category:	DSS
Trade Name:	Zebra Technologies Corp
Model :	ZBR4QL
RF Operating Frequency (ies)	2402 to 2480 MHz
Number of Channels :	79
Modulation :	GFSK
FCC ID :	I28MD-ZBR4QL
IC ID :	3798B-ZBR4QL

3 MODIFICATION

NONE

4 TEST SUMMARY

The product was tested in accordance with the following specifications. All Testing has been performed according to below product classification:

Spread Spectrum System / Device

Test Results Summary

Test Standard		Description	Pass / Fail
CFR 47 Part 15.247: 2008	RSS 210 Issue7: 2007		
15.203		Antenna Requirement	Pass
15.205	RSS210(A8.5)	Restricted Band of Operation	Pass
15.207(a)	RSSGen(7.2.2)	Conducted Emissions Voltage	Pass
15.247(a)(1)	RSS210(A8.1)	Channel Separation	Pass
15.247(a)(1)	RSS210(A8.1)	Occupied Bandwidth	Pass
15.247(a)(2)	RSS210 (A8.2)	Bandwidth	N/A
15.247(a)(1)	RSS210(A8.1)	Number of Hopping Channels	Pass
15.247(a)(1)	RSS210(A8.1)	Time of Occupancy	Pass
15.247(b)	RSS210(A8.4)	Output Power	Pass
15.247(c)	RSS210(A8.4)	Antenna Gain > 6 dBi	Pass
15.247(d)	RSS210(A8.5)	Conducted Spurious Emissions	Pass
15.209; 15.247(d)	RSS210(A8.5)	Radiated Spurious Emissions	Pass
15.247(e)	RSS210(A8.3)	Power Spectral Density	N/A
15.247(f)	RSS210(A8.3)	Hybrid System Requirement	N/A
15.247(g)	RSS210(A8.1)	Hopping Capability	Pass
15.247(h)	RSS210(A8.1)	Hopping Coordination Requirement	Pass
15.247(i)	RSSGen(5.5)	RF Exposure requirement	Pass
	RSSGen(4.8)	Receiver Spurious Emissions	Pass

ANSI C63.4: 2003/ RSS-Gen Issue 2: 2007

PS: All measurement uncertainties are not taken into consideration for all presented test result.

5 MEASUREMENTS, EXAMINATION AND DERIVED RESULTS

5.1 Antenna Requirement

Requirement(s): 47 CFR §15.203

An intentional radiator shall be designed to ensure that no antenna other than that furnished by the responsible party shall be used with the device.

Antenna requirement must meet at least one of the following:

- a) Antenna must be permanently attached to the device.
- b) Antenna must use a unique type of connector to attach to the device.
- c) Device must be professionally installed. Installer shall be responsible for ensuring that the correct antenna is employed with the device.

The antenna is printed inverted antenna. Antenna maximum gain is 7.2dBi for 2400–2483.5 MHz band

5.2 Conducted Emissions Voltage

Requirement :

Frequency of emission (MHz)	Conducted limit (dBµV)	
	Quasi-peak	Average
0.15–0.5	66 to 56*	56 to 46*
0.5–5	56	46
5–30	60	50

*Decreases with the logarithm of the frequency.

Procedures:

- All possible modes of operation were investigated. Only the 6 worst case emissions measured, using the correct CISPR and Average detectors, are reported. All other emissions were relatively insignificant.
 - A "-ve" margin indicates a PASS as it refers to the margin present below the limit line at the particular frequency.
 - Conducted Emissions Measurement Uncertainty
All test measurements carried out are traceable to national standards. The uncertainty of the measurement at a confidence level of approximately 95% (in the case where distributions are normal), with a coverage factor of 2, in the range 9kHz – 30MHz (Average & Quasi-peak) is ± 3.5 dB.
 - Environmental Conditions

Temperature	23°C
Relative Humidity	50%
Atmospheric Pressure	1019mbar
- Test Date : July 14-July 25 2008
Tested By :Choon Sian Ooi

Results:

Note –

Average Limit

Quasi-Peak Limit

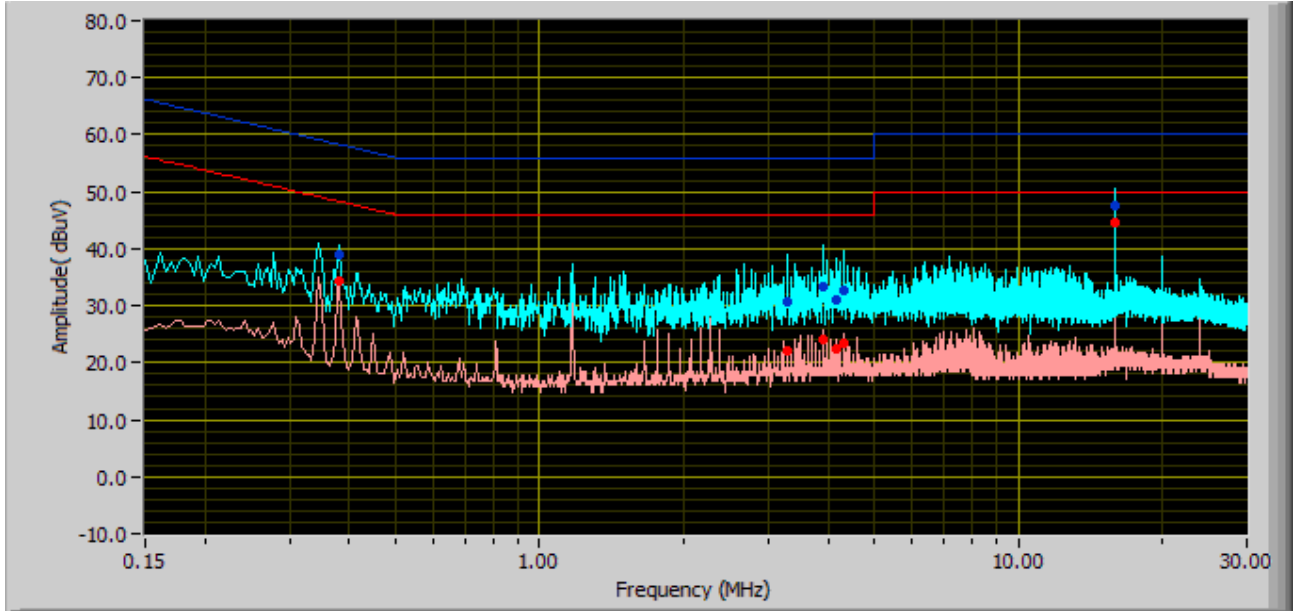

Phase Line Plot at 120Vac, 60Hz

Line Under Test	Freq. (MHz)	Corrected Amplitude (dBuV) QP	Limit (dBuV) QP	Margin (dB) QP	Corrected Amplitude (dBuV) AVG	Limit (dBuV) AVG	Margin (dB) AVG
Neutral	15.97	47.42	60.00	-12.58	44.46	50.00	-5.54
Neutral	3.91	33.26	56.00	-22.74	24.10	46.00	-21.90
Neutral	4.31	32.72	56.00	-23.28	23.32	46.00	-22.68
Neutral	3.29	30.68	56.00	-25.32	21.98	46.00	-24.02
Neutral	0.38	38.84	58.28	-19.43	34.34	48.28	-13.94
Neutral	4.18	31.19	56.00	-24.81	22.45	46.00	-23.55

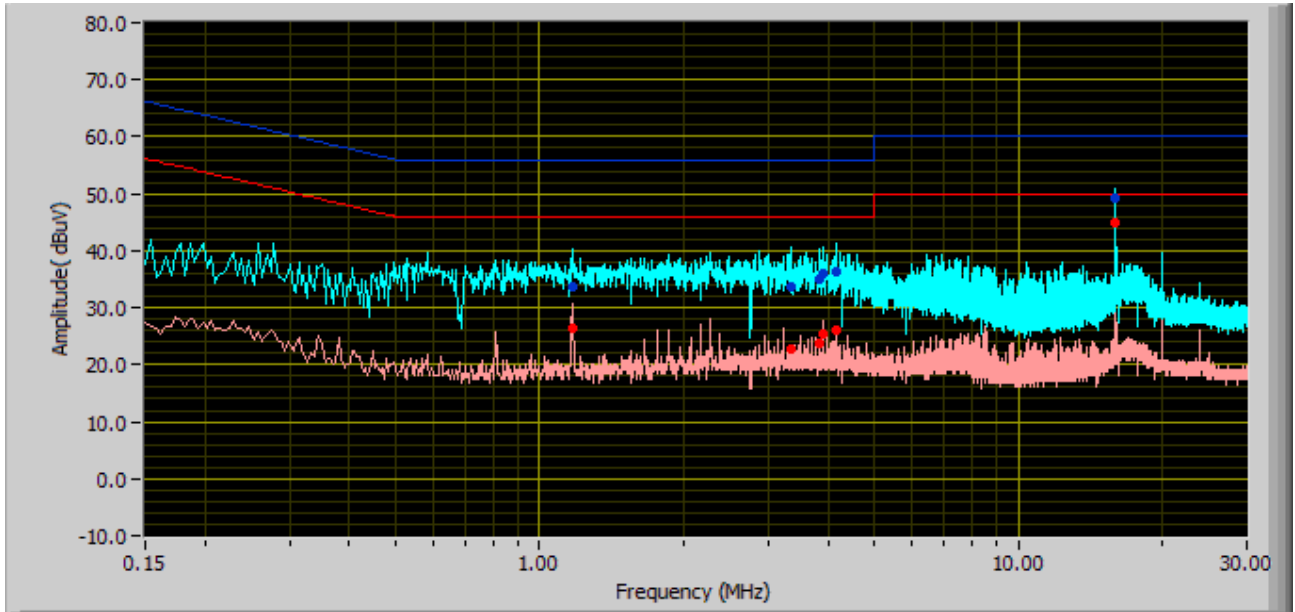

Neutral Line Plot at 120Vac, 60Hz

Line Under Test	Freq. (MHz)	Corrected Amplitude (dBuV) QP	Limit (dBuV) QP	Margin (dB) QP	Corrected Amplitude (dBuV) AVG	Limit (dBuV) AVG	Margin (dB) AVG
Line	15.98	49.38	60.00	-10.62	44.98	50.00	-5.02
Line	4.18	36.33	56.00	-19.67	25.93	46.00	-20.07
Line	3.35	33.59	56.00	-22.41	22.70	46.00	-23.30
Line	3.91	36.05	56.00	-19.95	25.30	46.00	-20.70
Line	3.83	34.85	56.00	-21.15	23.91	46.00	-22.09
Line	1.17	33.60	56.00	-22.40	26.53	46.00	-19.47

5.3 Channel Separation

1. Conducted Measurement
EUT was set for low , mid, high channel with modulated mode and highest RF output power. The spectrum analyzer was connected to the antenna terminal.
2. Environmental Conditions

Temperature	23°C
Relative Humidity	50%
Atmospheric Pressure	1019mbar
3. Conducted Emissions Measurement Uncertainty
All test measurements carried out are traceable to national standards. The uncertainty of the measurement at a confidence level of approximately 95% (in the case where distributions are normal), with a coverage factor of 2, in the range 30MHz – 40GHz is ± 1.5 dB.
4. Test Date : July 14-July 25 2008
Tested By :Choon Sian Ooi

Requirement(s): 47 CFR §15.247(a)(1)

Procedures: The Channel Separation was measured conducted using a spectrum analyzer at low, mid, and hi channels.

Note: hopping channel carrier frequencies shall be separated by a minimum of 25 kHz or the 20 dB bandwidth of the hopping channel.

Alternatively, frequency hopping systems operating in the 2400–2483.5 MHz band may have hopping channel carrier frequencies that are separated by 25 kHz or two-thirds of the 20 dB bandwidth of the hopping channel, whichever is greater, provided the systems operate with an output power no greater than 125 mW.

Channel	Channel Frequency (MHz)	Channel Separation (MHz)
Low	2402	1.025
Mid	2441	1.020
High	2480	1.030

Channel Separation - Low Channel

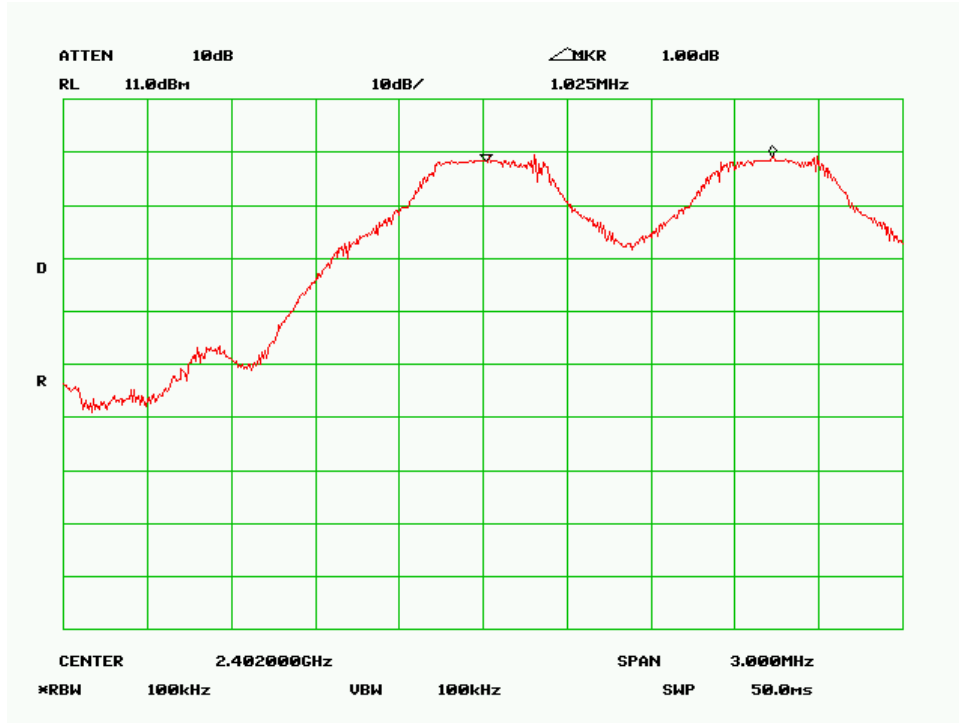

Channel Separation - Mid Channel

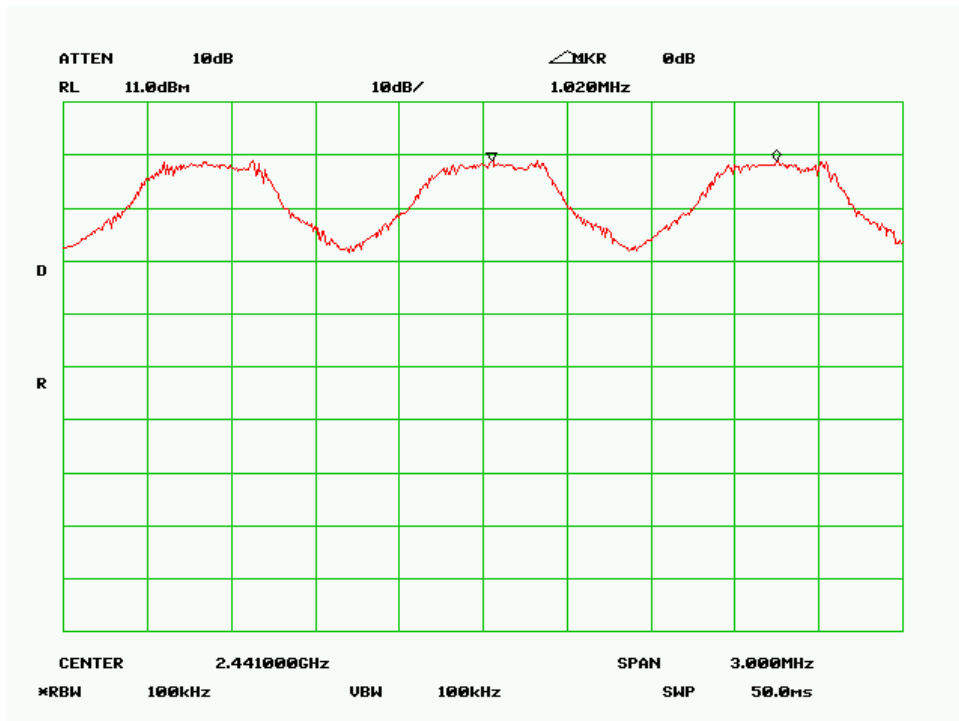



Channel Separation – High Channel

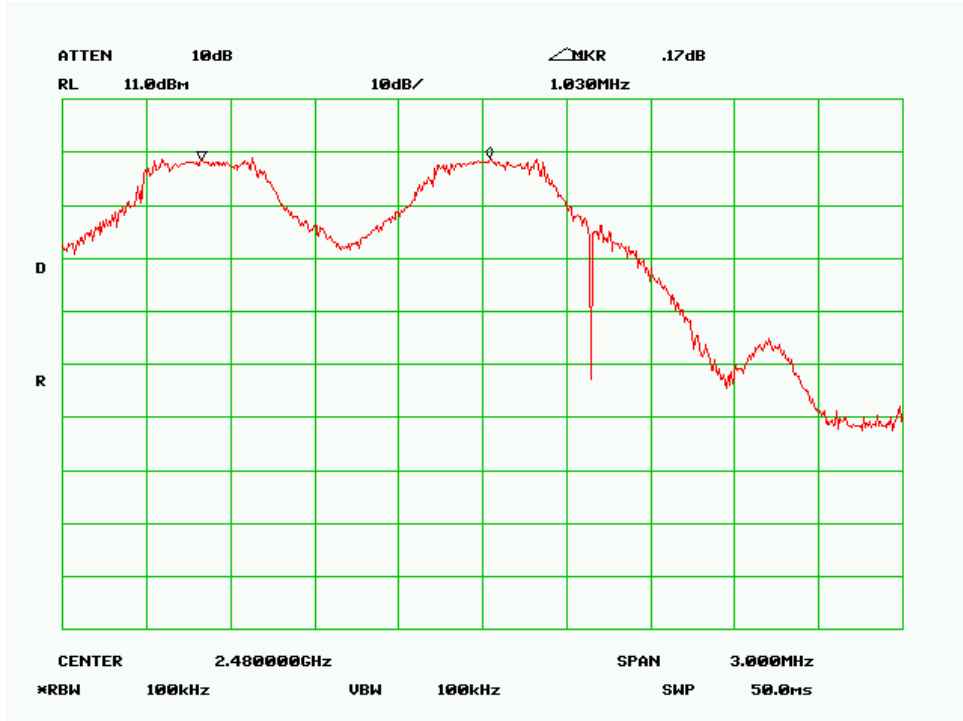

5.4 20dB & 99% Occupied Bandwidth

1. Conducted Measurement
EUT was set for low , mid, high channel with modulated mode and highest RF output power. The spectrum analyzer was connected to the antenna terminal.
2. Environmental Conditions

Temperature	23°C
Relative Humidity	50%
Atmospheric Pressure	1019mbar
3. Conducted Emissions Measurement Uncertainty
All test measurements carried out are traceable to national standards. The uncertainty of the measurement at a confidence level of approximately 95% (in the case where distributions are normal), with a coverage factor of 2, in the range 30MHz – 40GHz is ±1.5dB.
4. Test Date : July 14-July 25 2008
Tested By :Choon Sian Ooi

Requirement(s): 47 CFR §15.247(a)(1)

Procedures: The 20dB bandwidths were measured conducted using a spectrum analyzer at low, mid, and hi channels.

Modulation-GFSK

Channel	Channel Frequency (MHz)	20 dB Channel Bandwidth (KHz)	99% Bandwidth (KHz)
Low	2402	885	880
Mid	2441	875	880
High	2480	885	890

Refer to the attached plots.
 Modulation GFSK

20 dB Bandwidth - Low Channel

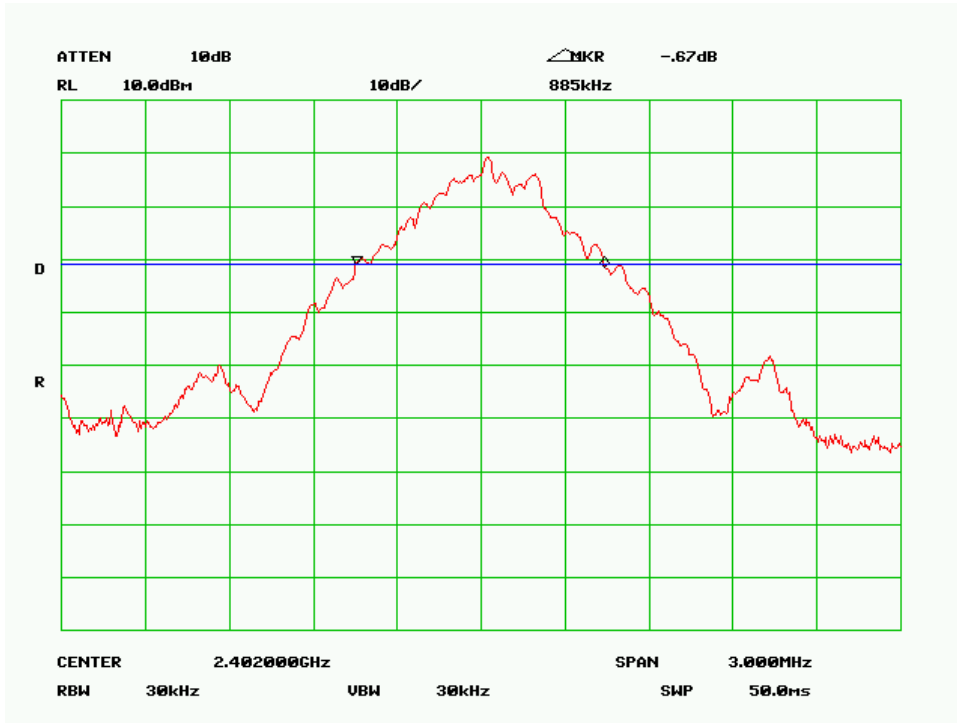

20 dB Bandwidth - Mid Channel

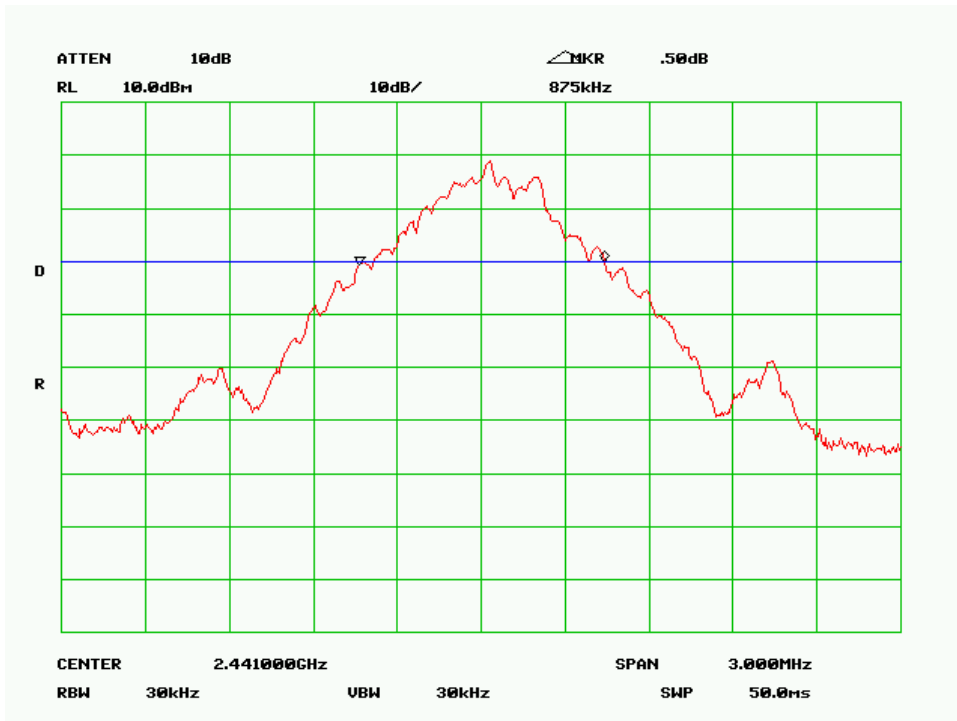

20 dB Bandwidth - High Channel

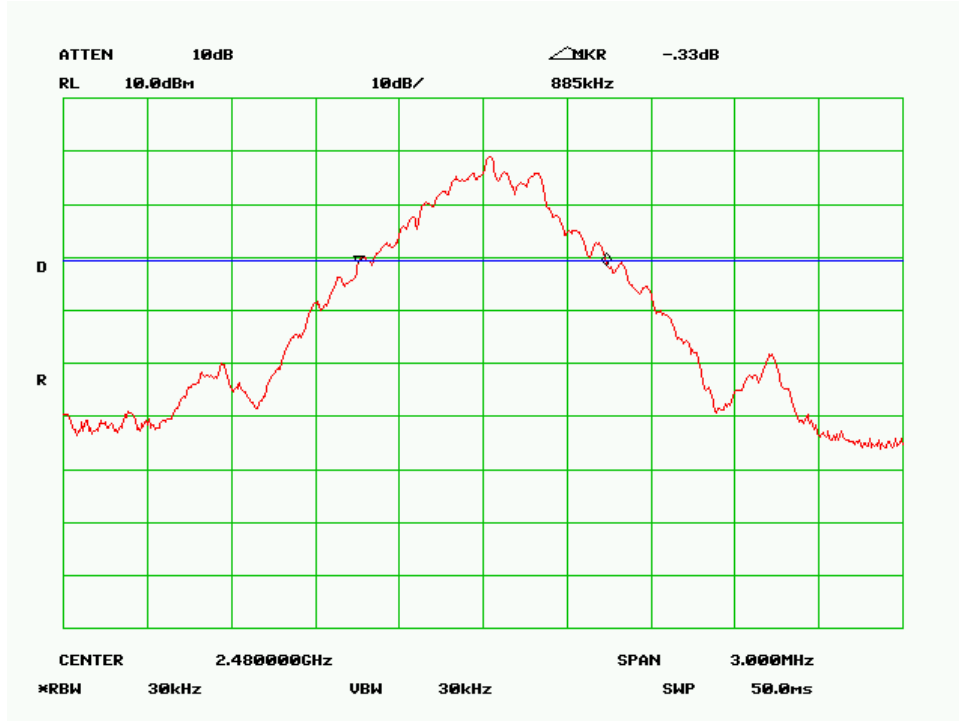

99% Bandwidth - Low Channel

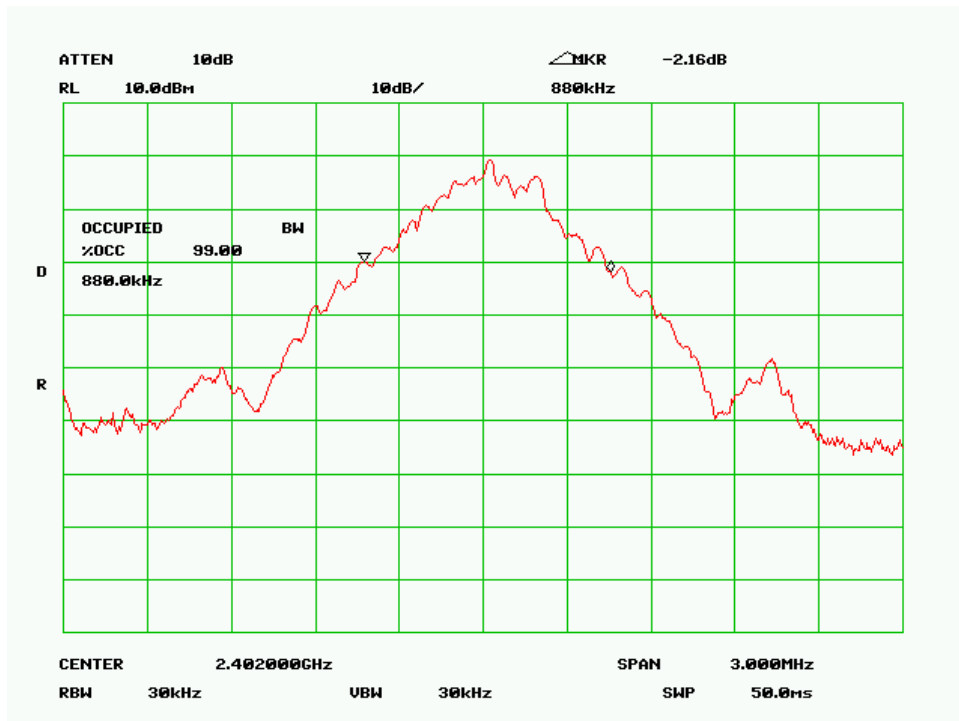



99% Bandwidth - Mid Channel

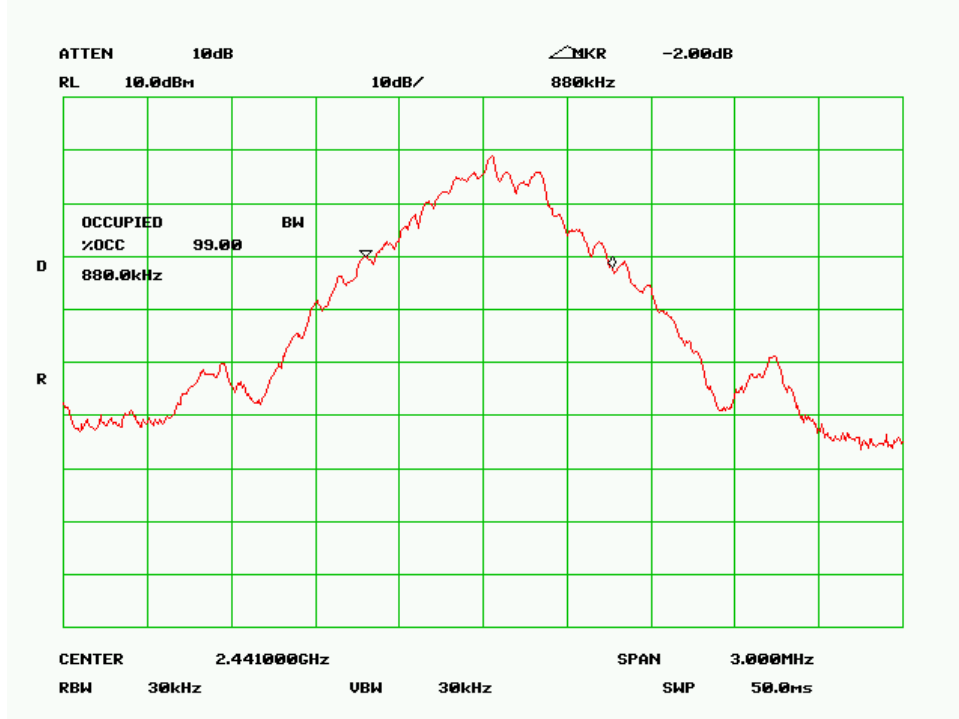

99% Bandwidth - High Channel

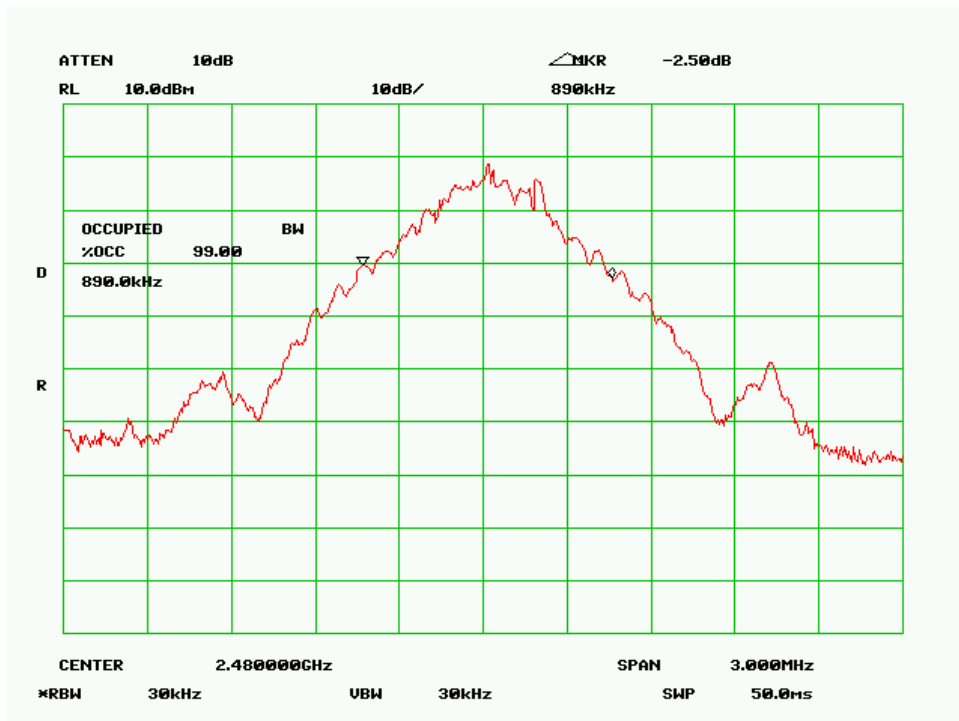

5.10 Number of Hopping Channel

1. Conducted Measurement
EUT was set for low , mid, high channel with modulated mode and highest RF output power.
The spectrum analyzer was connected to the antenna terminal.
2. Conducted Emissions Measurement Uncertainty
All test measurements carried out are traceable to national standards. The uncertainty of the measurement at a confidence level of approximately 95% (in the case where distributions are normal), with a coverage factor of 2, in the range 30MHz – 40GHz is ± 1.5 dB.
3. Environmental Conditions

Temperature	23°C
Relative Humidity	50%
Atmospheric Pressure	1019mbar
4. Test Date : July 14-July 25 2008
Tested By :Choon Sian Ooi

Standard Requirement : 47 CFR §15.247(a)(1)

Frequency hopping systems in the 2400–2483.5 MHz band shall use at least 15 channels.

Procedures: The Number of Hopping Channel measurement was taken conducted using a spectrum analyzer.

RBW=100 KHz, VBW > RBW

Test Result:

Total Channel: 79 Channels

Number of Hopping Channel

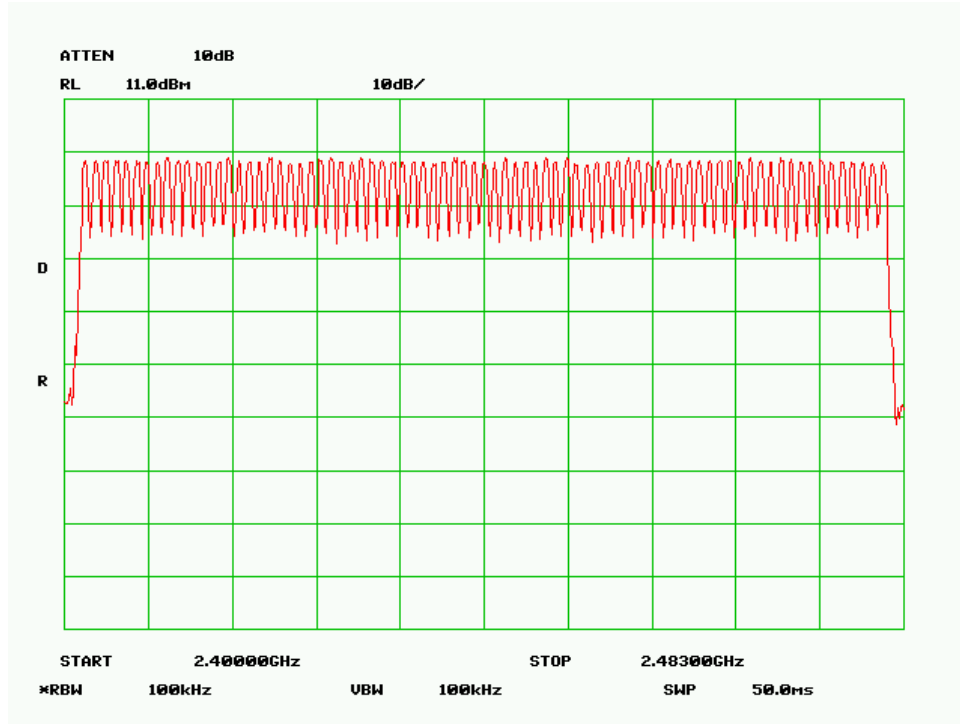

5.10 Time of Occupancy

1. **Conducted Measurement**
EUT was set for low , mid, high channel with modulated mode and highest RF output power. The spectrum analyzer was connected to the antenna terminal.
2. **Conducted Emissions Measurement Uncertainty**
All test measurements carried out are traceable to national standards. The uncertainty of the measurement at a confidence level of approximately 95% (in the case where distributions are normal), with a coverage factor of 2, in the range 30MHz – 40GHz is ± 1.5 dB.
3. **Environmental Conditions**

Temperature	23°C
Relative Humidity	50%
Atmospheric Pressure	1019mbar
4. **Test Date : July 14-July 25 2008**
Tested By :Choon Sian Ooi

Standard Requirement : 47 CFR §15.247(a)(1)

The average time of occupancy on any channel shall not be greater than 0.4 seconds within a period of 0.4 seconds multiplied by the number of hopping channels employed. Frequency hopping systems may avoid or suppress transmissions on a particular hopping frequency provided that a minimum of 15 channels are used

Procedures: The Time of Occupancy measurement was taken conducted using a spectrum analyzer.

Test Result:

Channel	Channel Frequency (MHz)	Dwell Time (sec)	Limit (sec)
Low	2402	0.34397	0.4
Mid	2441	0.34073	0.4
High	2480	0.34146	0.4

Note: *Dwell Time* = On-time * number of times the specific channel on during 31.6sec sweep.

Low Channel (Sweep in 6.32sec)

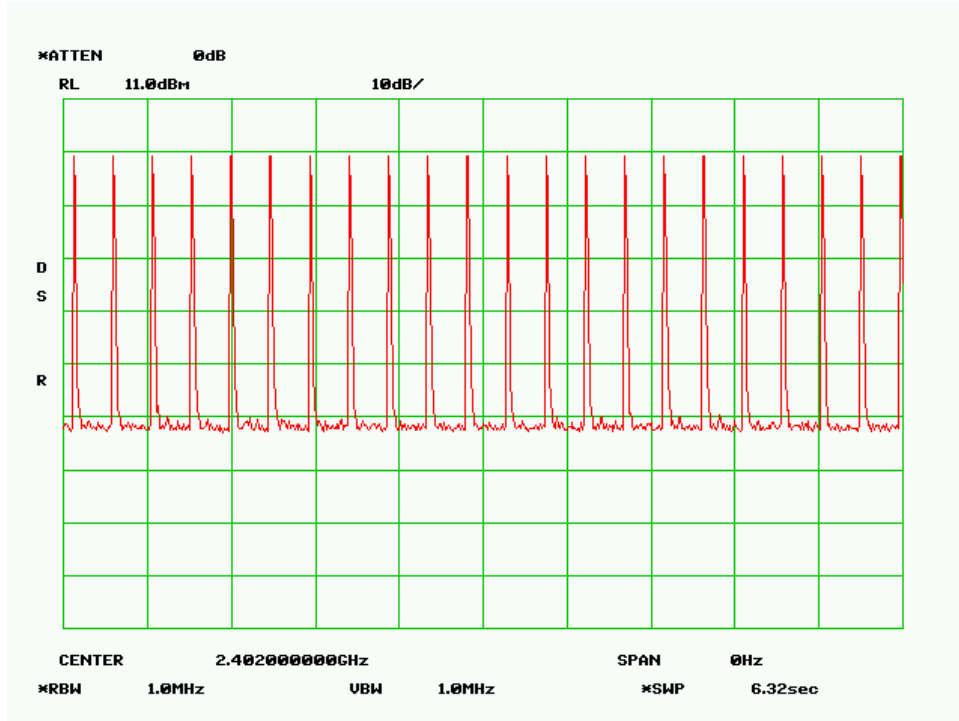

Low Channel (Sweep in 35.4msec)

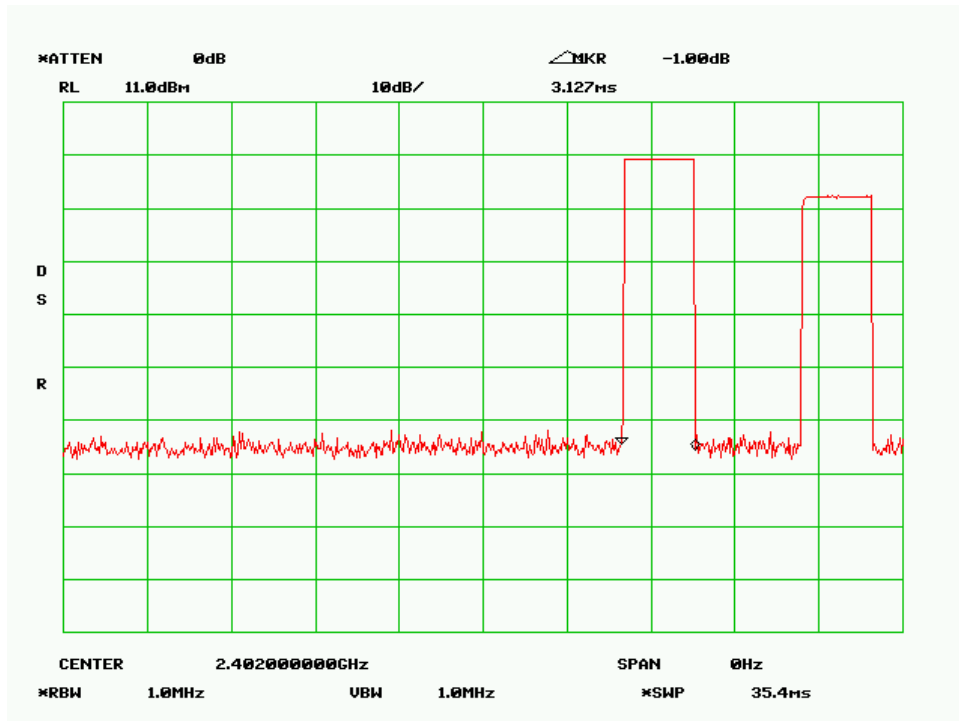

Mid Channel (Sweep in 6.32sec)

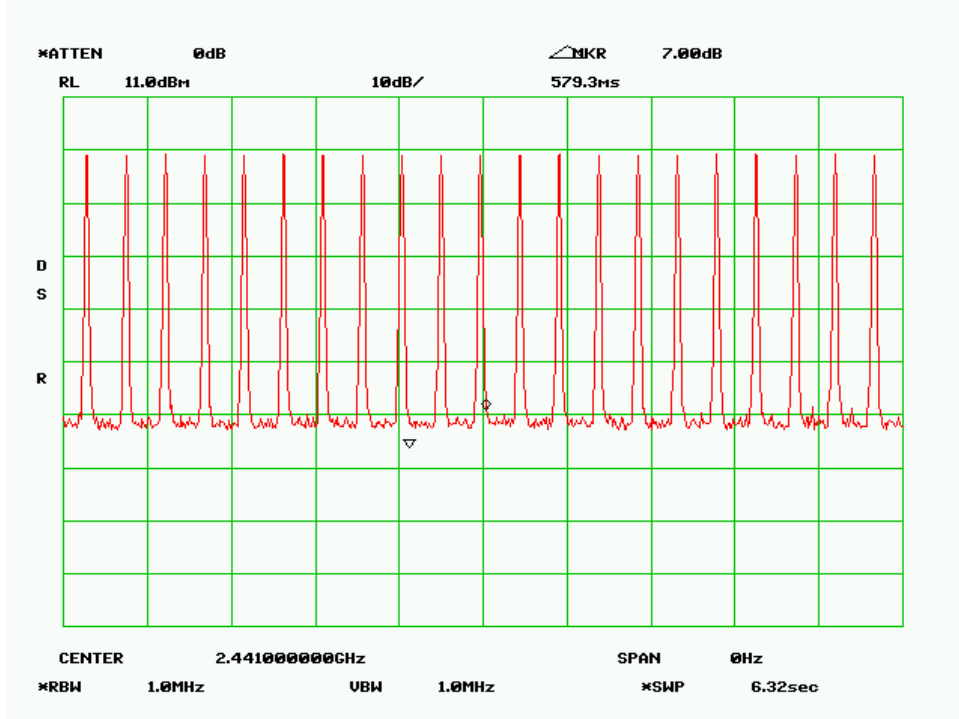

Mid Channel (Sweep in 35.4msec)

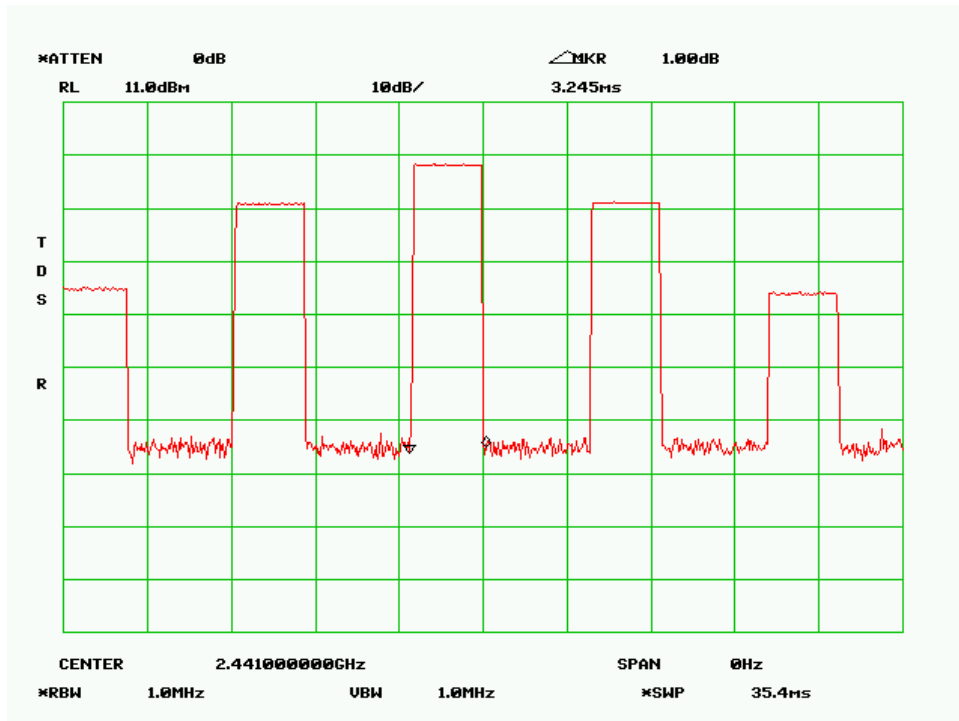

High Channel (Sweep in 6.32sec)

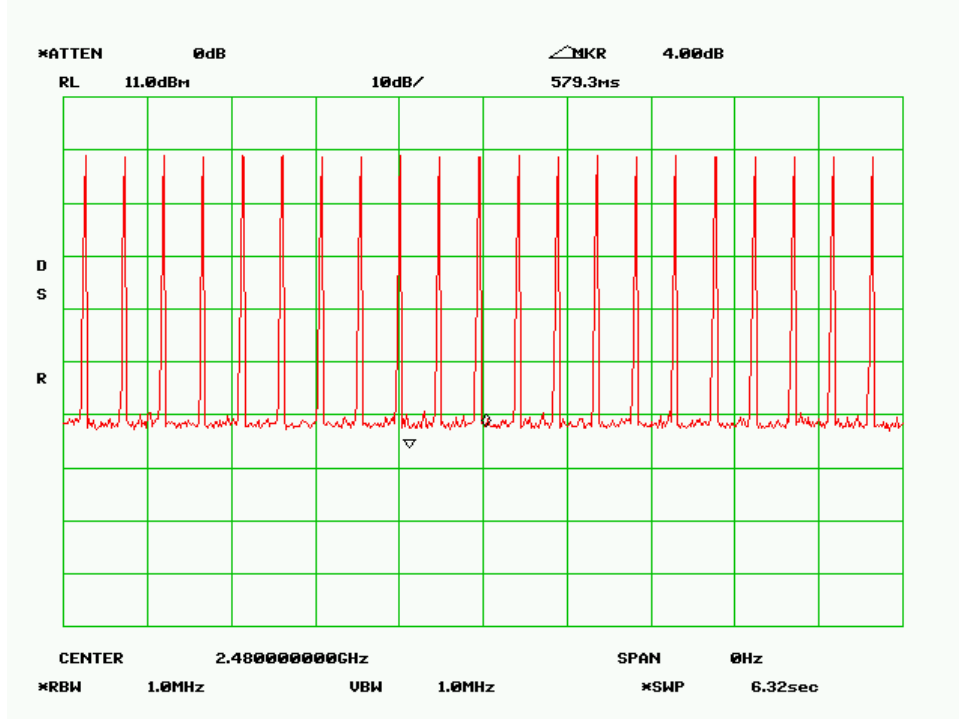

High Channel (Sweep in 34.8msec)

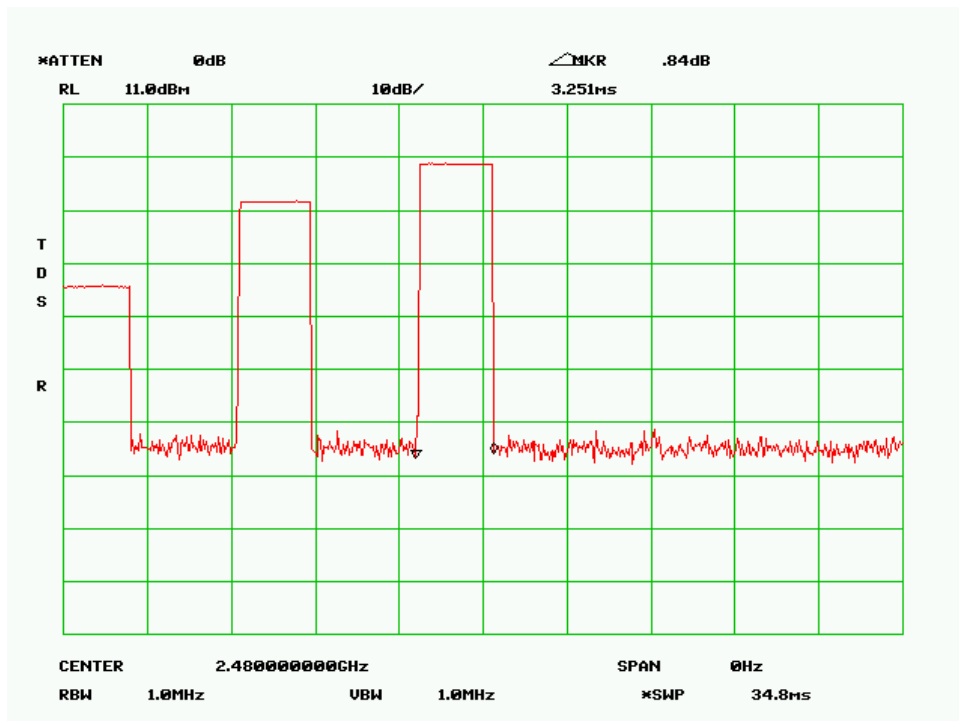

5.10 Peak Output Power

1. **Conducted Measurement**
EUT was set for low , mid, high channel with modulated mode and highest RF output power. The spectrum analyzer was connected to the antenna terminal.
2. **Conducted Emissions Measurement Uncertainty**
All test measurements carried out are traceable to national standards. The uncertainty of the measurement at a confidence level of approximately 95% (in the case where distributions are normal), with a coverage factor of 2, in the range 30MHz – 40GHz is ± 1.5 dB.
3. **Environmental Conditions**

Temperature	23°C
Relative Humidity	50%
Atmospheric Pressure	1019mbar
4. Test Date : July 14-July 25 2008
Tested By :Choon Sian Ooi

Standard Requirement : 47 CFR §15.247(b)

Procedures: The peak output power was measured conducted using a spectrum analyzer at low, mid, and hi channels. Peak detector was set to measure the power output. The power is converted from watt to dBm, therefore, 1 watt = 30 dBm. The highest antenna gain that will be used is 2.64 dBi.

Note: For frequency hopping systems operating in the 2400–2483.5 MHz band employing at least 75 non-overlapping hopping channels, and all frequency hopping systems in the 5725–5850 MHz band: 1 watt.

Test Result :

Modulation-GFSK

Channel	Channel Frequency (MHz)	Measured Output Power (dBm)	Peak Output Power Limit (dBm)
Low	2402	0.33	28.8
Mid	2441	0	28.8
High	2480	0	28.8

Modulation-GFSK

Output Power Low Channel

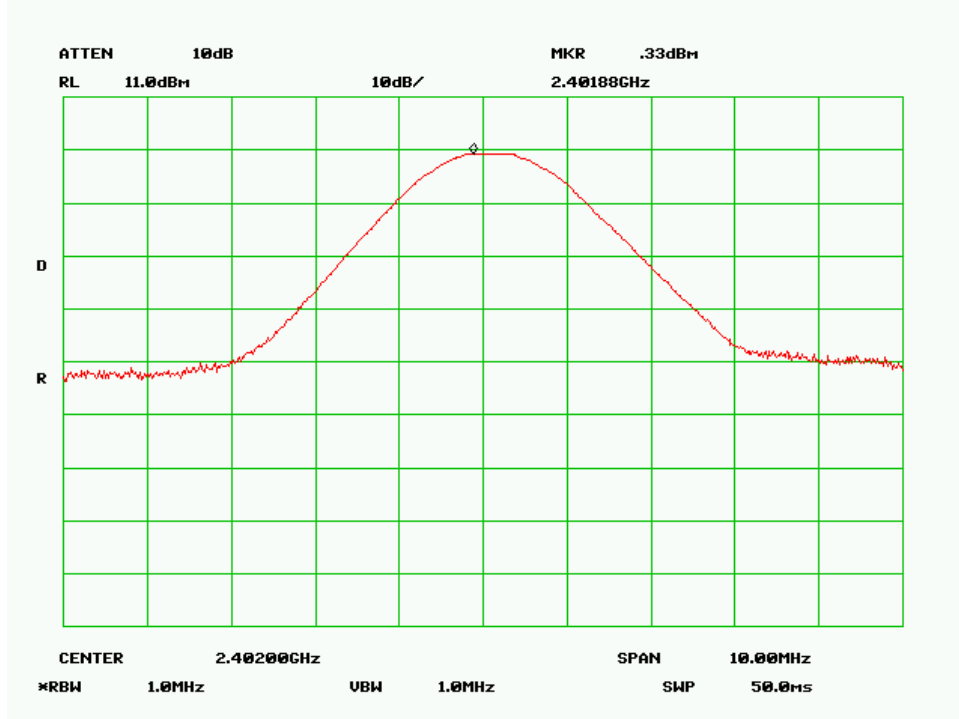

Output Power Mid Channel

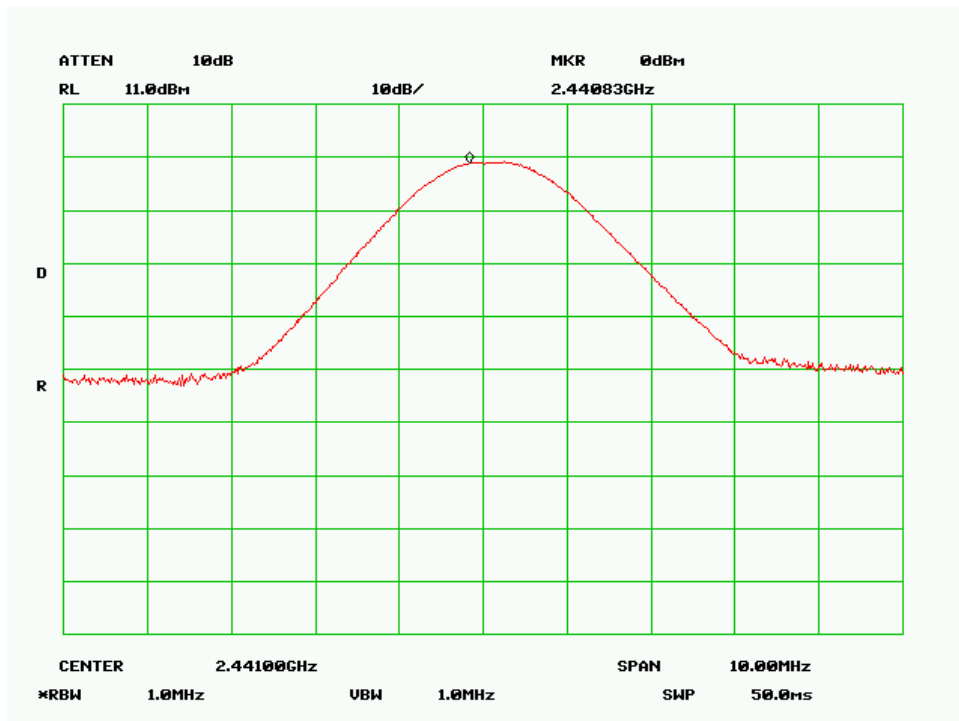

Output Power High Channel

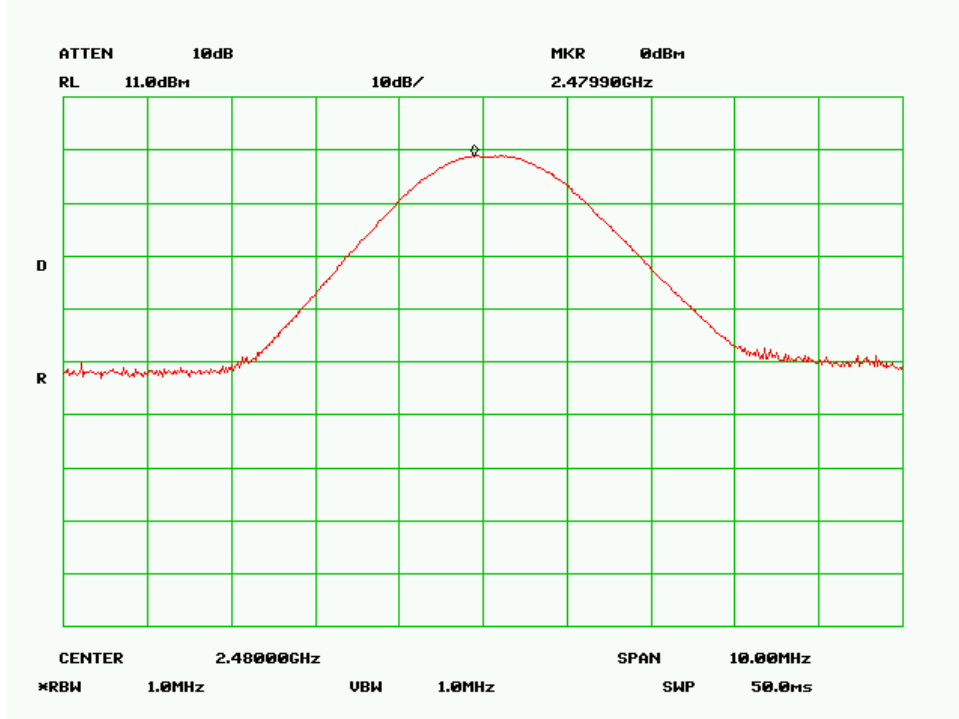

5.10 Antenna Port Emission

1. Conducted Measurement
 EUT was set for low , mid, high channel with modulated mode and highest RF output power.
 The spectrum analyzer was connected to the antenna terminal.
2. Conducted Emissions Measurement Uncertainty
 All test measurements carried out are traceable to national standards. The uncertainty of the measurement at a confidence level of approximately 95% (in the case where distributions are normal), with a coverage factor of 2, in the range 30MHz – 40GHz is $\pm 1.5\text{dB}$.
3. Environmental Conditions

Temperature	23°C
Relative Humidity	50%
Atmospheric Pressure	1019mbar
4. Test Date : July 14-July 25 2008
 Tested By :Choon Sian Ooi

Standard Requirement : 47 CFR §15.247(d)

Procedures: The conducted spurious emissions were measured conducted using a spectrum analyzer at low, mid, and hi channels. The limit was determined by attenuating 20 dB of the RF peak power output

Test Result:

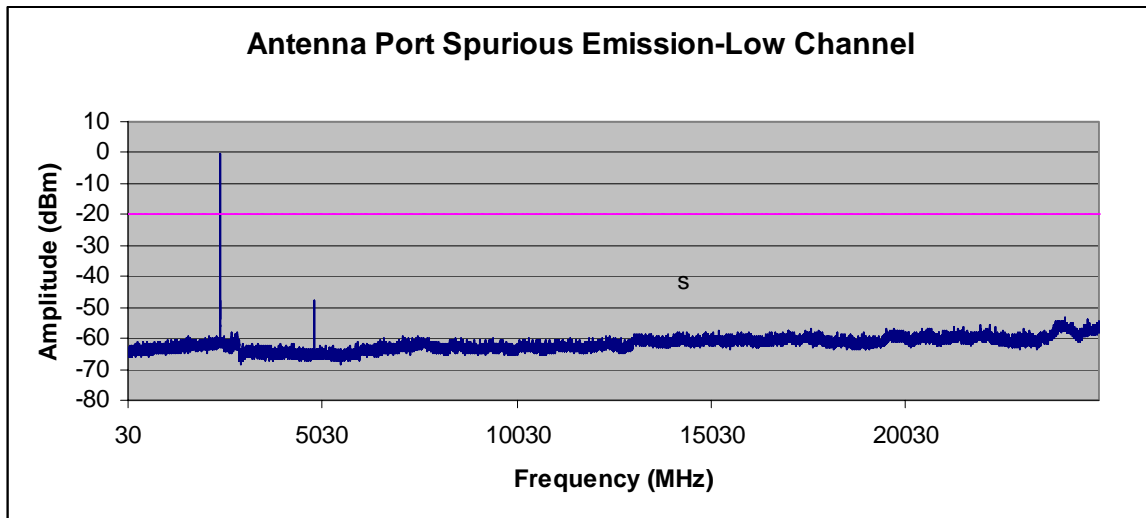

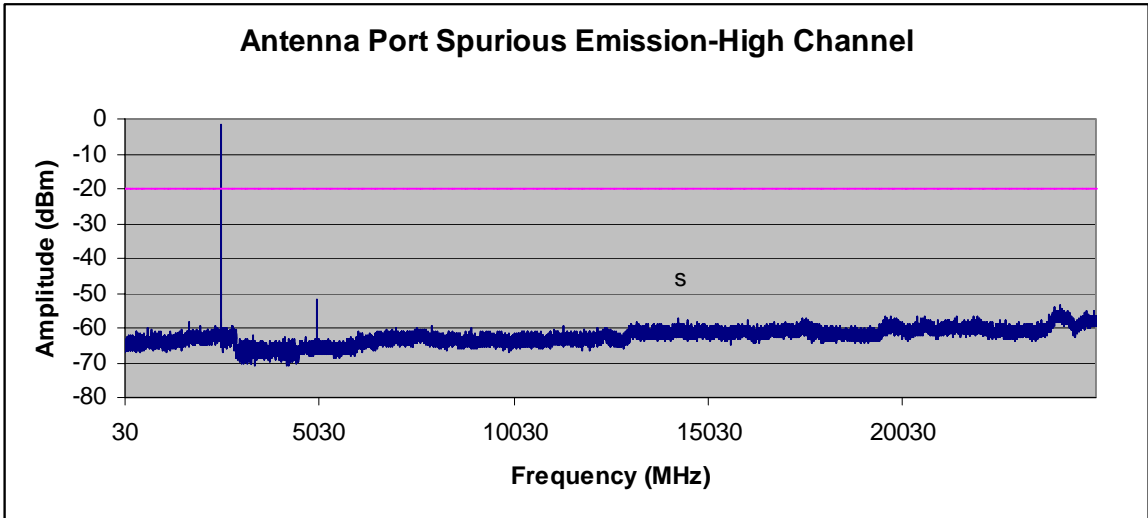
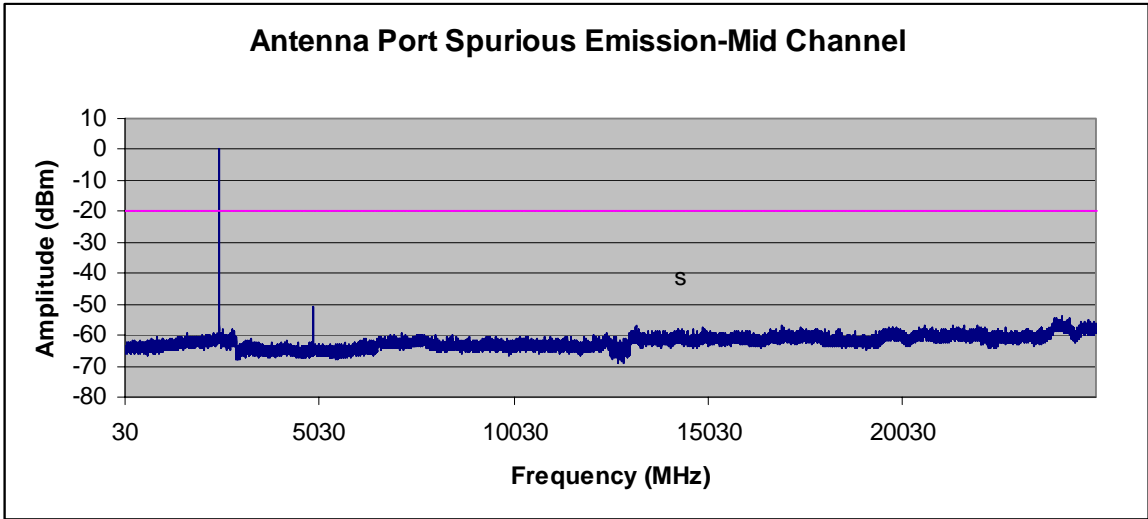

5.10 Radiated Spurious Emission < 1GHz

1. All possible modes of operation were investigated. Only the 6 worst case emissions measured, using the correct CISPR detectors, are reported. All other emissions were relatively insignificant.
2. A "-ve" margin indicates a PASS as it refers to the margin present below the limit line at the particular frequency.

3. Radiated Emissions Measurement Uncertainty

All test measurements carried out are traceable to national standards. The uncertainty of the measurement at a confidence level of approximately 95% (in the case where distributions are normal), with a coverage factor of 2, in the range 30MHz – 1GHz & 1GHz above (3m & 10m) is +/-6dB.

4	Environmental Conditions	Temperature	23°C
		Relative Humidity	50%
		Atmospheric Pressure	1019mbar

Test Date : July 14-July 25 2008

Tested By :Choon Sian Ooi

Standard Requirement : 47 CFR §15.247(d)

Procedures: Radiated emissions were measured according to ANSI C63.4. The EUT was set to transmit at the highest output power. The EUT was set to transmit at mid channel. Note that setting the channel other than mid, the spurious emissions are the same.

The limit is converted from microvolts/meter to decibel microvolts/meter.

Sample Calculation: Corrected Amplitude = Raw Amplitude(dBμV/m) + ACF(dB) + Cable Loss(dB)

Test Result:

Radiated Emission Plot (Transmit Mode)

Host EUT: QL220 PLUS

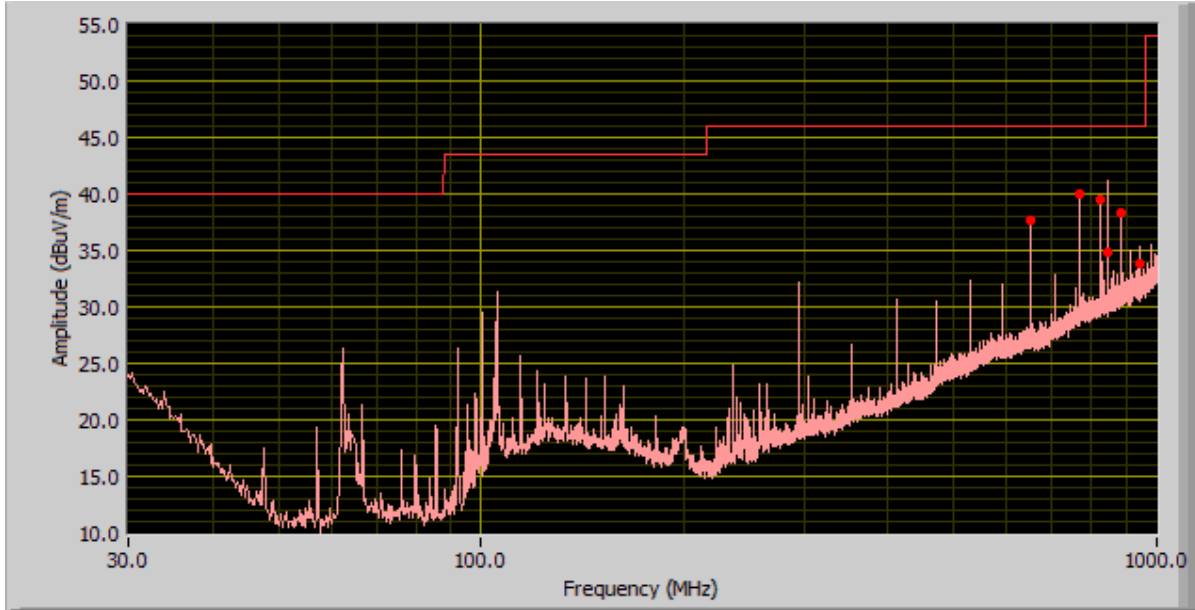

Test Data

Frequency (MHz)	Quasi-Peak (dBµV/m)	Turntable position (deg)	Polarity	Antenna height (cm)	Limit (dBµV/m)	Margin (dB)
845.65	34.52	262.00	V	224.00	46.00	-11.48
766.77	39.92	302.00	H	109.00	46.00	-6.08
825.74	39.49	299.00	H	100.00	46.00	-6.51
884.70	38.30	329.00	H	148.00	46.00	-7.70
648.81	37.65	293.00	H	114.00	46.00	-8.35
943.73	33.91	330.00	H	148.00	46.00	-12.09

Radiated Emission Plot (Transmit Mode)

Host EUT: QL320 PLUS

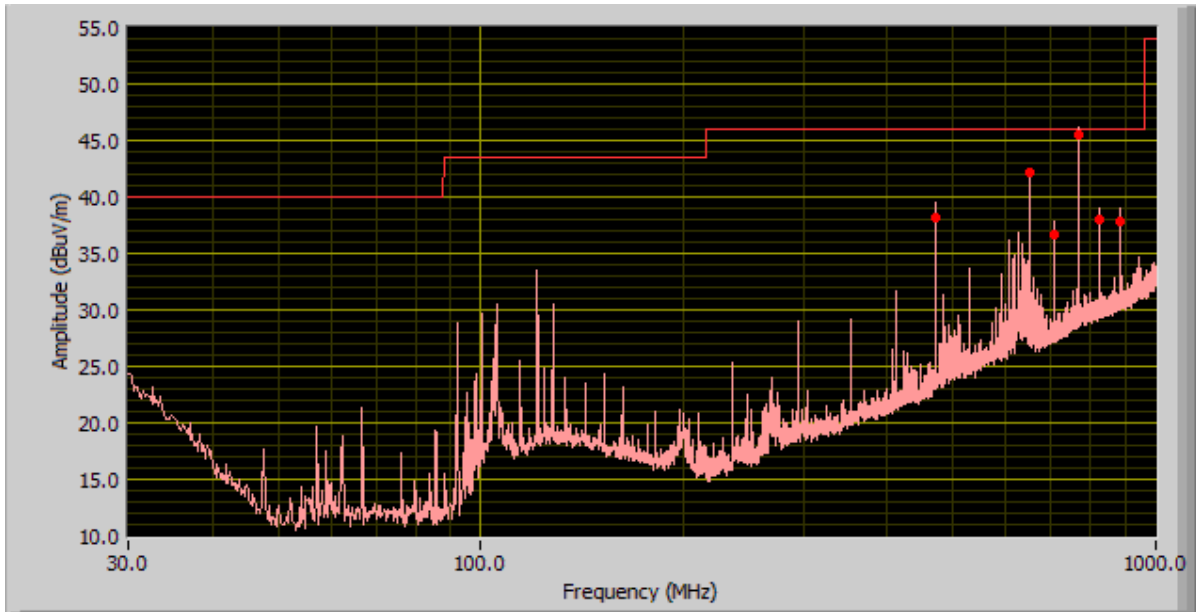

Test Data

Frequency (MHz)	Quasi-Peak (dBμV/m)	Turntable position (deg)	Polarity	Antenna height (cm)	Limit (dBμV/m)	Margin (dB)
766.77	45.51	313.00	H	103.00	46.00	-0.49
648.81	42.22	313.00	H	134.00	46.00	-3.78
471.85	38.13	116.00	H	200.00	46.00	-7.87
884.71	37.81	351.00	H	100.00	46.00	-8.19
825.74	38.05	300.00	H	103.00	46.00	-7.95
707.77	36.62	298.00	H	110.00	46.00	-9.38

Radiated Emission Plot (Transmit Mode)

Host EUT: QL420 PLUS

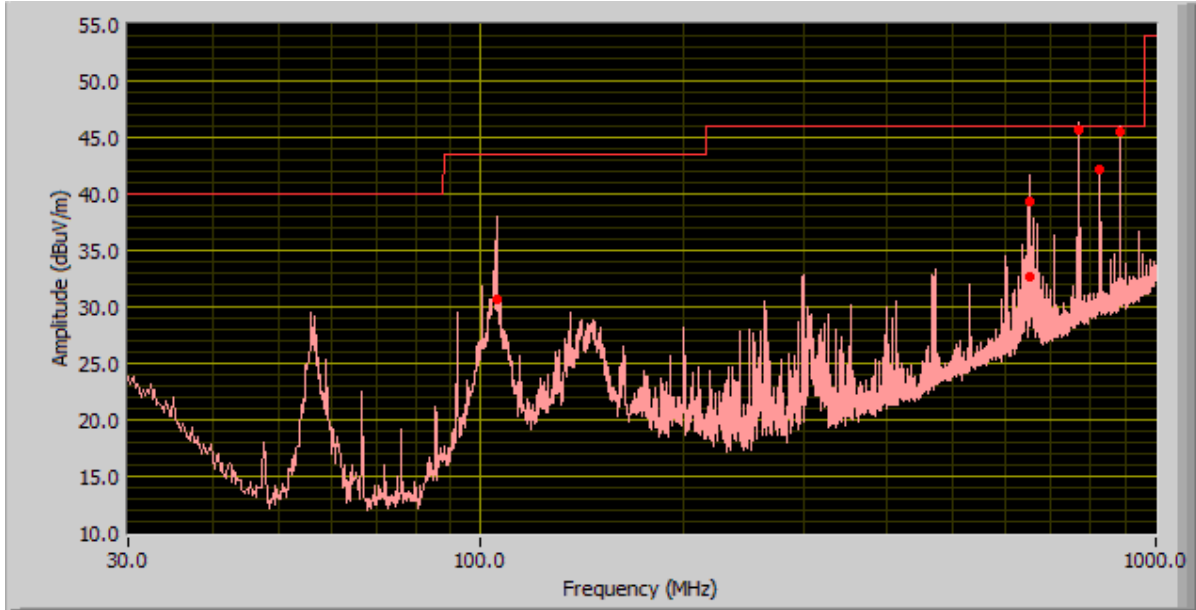

Test Data

Frequency (MHz)	Quasi-Peak (dBµV/m)	Turntable position (deg)	Polarity	Antenna height (cm)	Limit (dBµV/m)	Margin (dB)
766.77	45.71	305.00	H	104.00	46.00	-0.29
884.72	45.57	63.00	H	101.00	46.00	-0.43
825.74	42.18	67.00	H	101.00	46.00	-3.82
648.79	39.33	237.00	H	254.00	46.00	-6.67
105.67	30.66	175.00	V	318.00	43.50	-12.84
651.95	32.66	61.00	H	100.00	46.00	-13.34

Radiated Emission Plot (Receive Mode)

Host EUT: QL220 PLUS

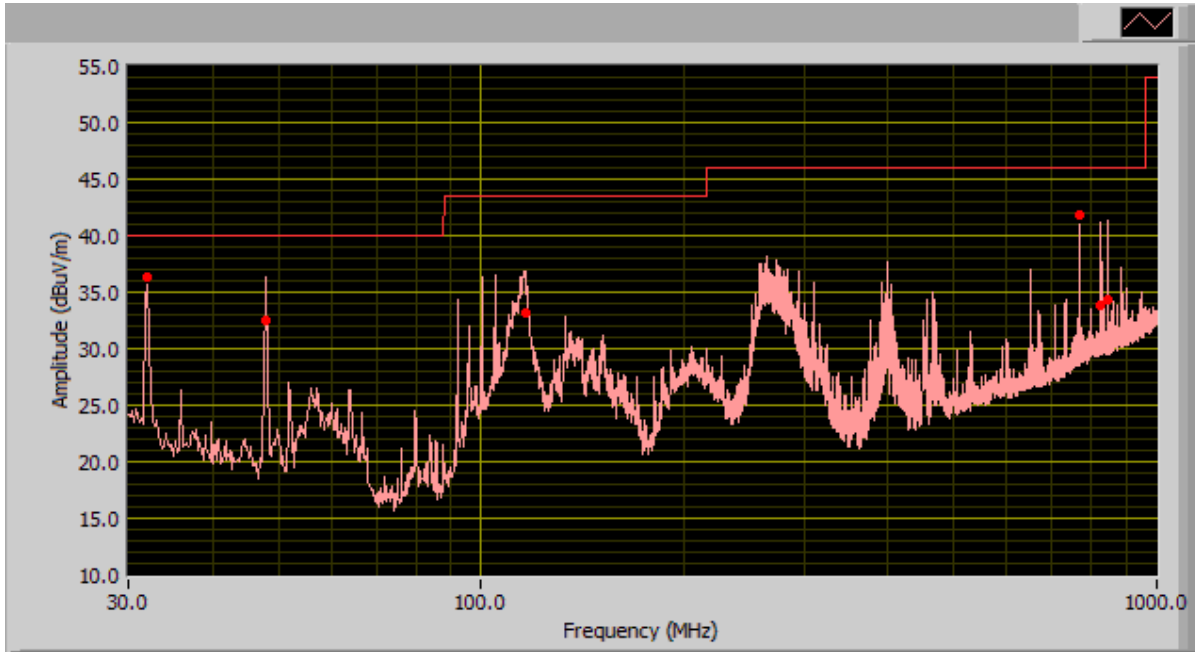

Test Data

Frequency (MHz)	Quasi-Peak (dBµV/m)	Turntable position (deg)	Polarity	Antenna height (cm)	Limit (dBµV/m)	Margin (dB)
47.99	32.56	344.00	V	196.00	40.00	-7.44
32.03	36.28	162.00	V	122.00	40.00	-3.72
845.41	34.26	185.00	V	171.00	46.00	-11.74
824.53	33.82	353.00	V	361.00	46.00	-12.18
766.76	41.80	300.00	H	100.00	46.00	-4.20
116.30	33.16	98.00	H	243.00	43.50	-10.34

Radiated Emission Plot (Receive Mode)

Host EUT: QL320 PLUS

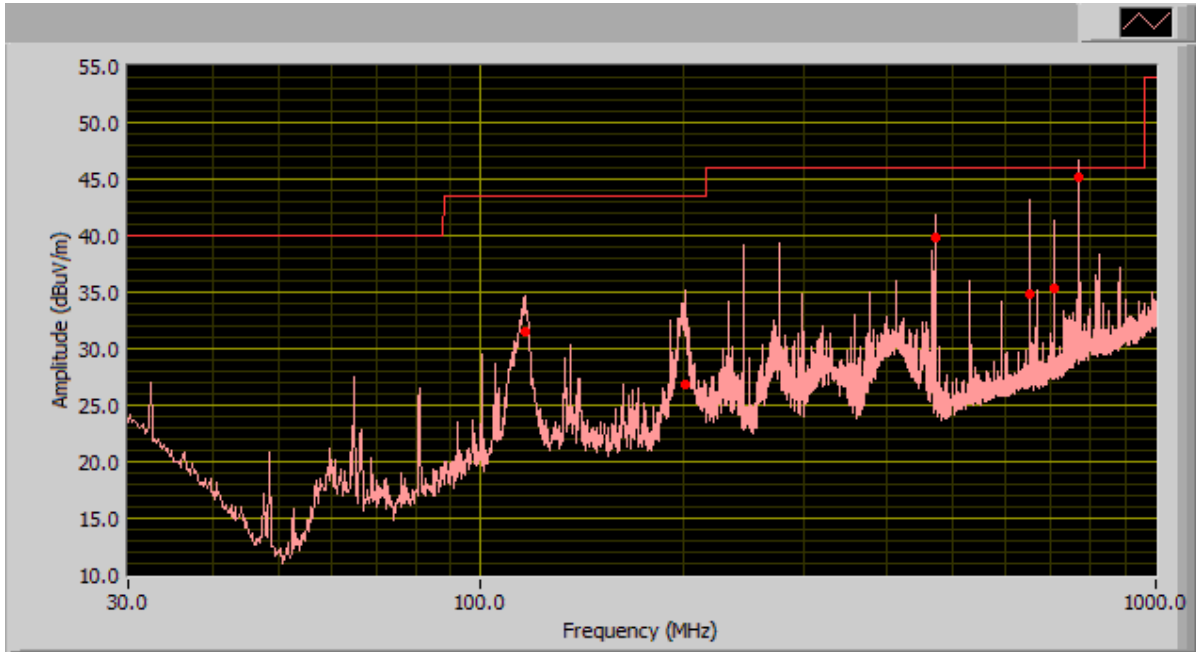

Test Data

Frequency (MHz)	Quasi-Peak (dBµV/m)	Turntable position (deg)	Polarity	Antenna height (cm)	Limit (dBµV/m)	Margin (dB)
766.76	45.17	300.00	H	105.00	46.00	-0.83
648.80	34.87	126.00	V	145.00	46.00	-11.13
200.55	26.83	20.00	V	102.00	43.50	-16.67
471.84	39.77	56.00	V	111.00	46.00	-6.23
115.98	31.42	89.00	H	129.00	43.50	-12.08
707.74	35.30	353.00	V	155.00	46.00	-10.70

Radiated Emission Plot (Receive Mode)

Host EUT: QL420 PLUS

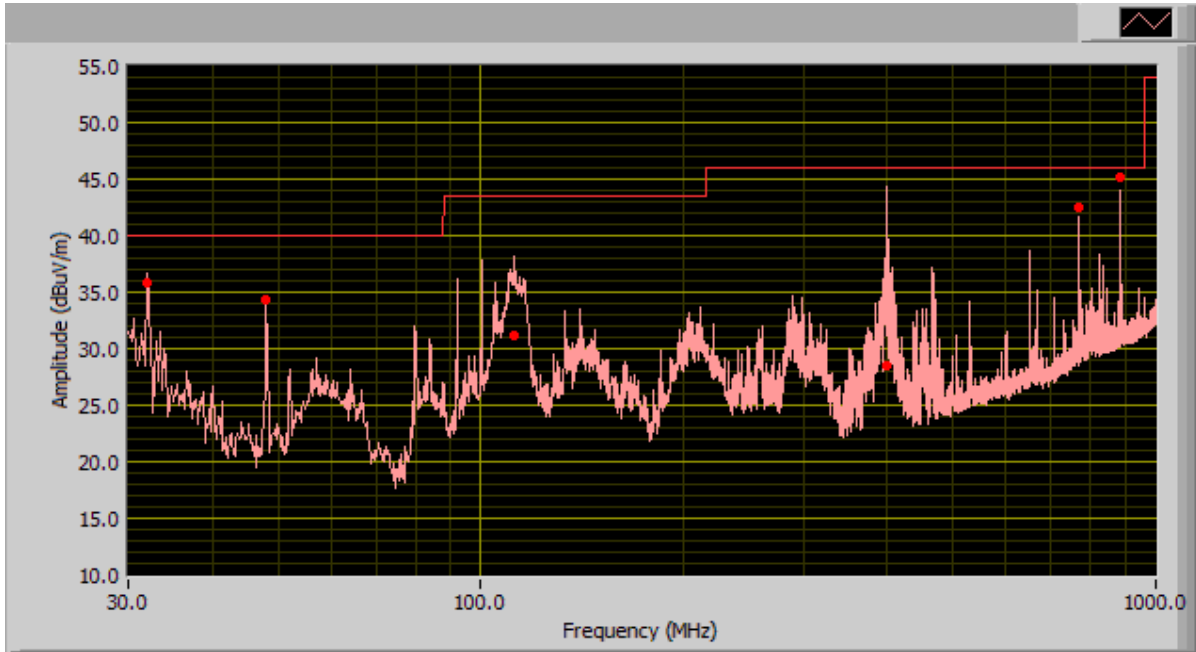

Test Data

Frequency (MHz)	Quasi-Peak (dBµV/m)	Turntable position (deg)	Polarity	Antenna height (cm)	Limit (dBµV/m)	Margin (dB)
400.39	28.47	117.00	H	174.00	46.00	-17.53
884.75	45.11	234.00	V	105.00	46.00	-0.89
31.91	35.78	84.00	V	101.00	40.00	-4.22
766.76	42.47	151.00	H	104.00	46.00	-3.53
112.20	31.14	292.00	V	101.00	43.50	-12.36
47.90	34.33	353.00	V	126.00	40.00	-5.67

5.10 Radiated Spurious Emissions > 1GHz & Band Edge

1. All possible modes of operation were investigated. Only the 6 worst case emissions measured, using the correct CISPR detectors, are reported. All other emissions were relatively insignificant.
2. A "-ve" margin indicates a PASS as it refers to the margin present below the limit line at the particular frequency.

3. Radiated Emissions Measurement Uncertainty

All test measurements carried out are traceable to national standards. The uncertainty of the measurement at a confidence level of approximately 95% (in the case where distributions are normal), with a coverage factor of 2, in the range 30MHz – 1GHz & 1GHz above (3m & 10m) is +/-6dB.

4. Environmental Conditions

Temperature	23°C
Relative Humidity	50%
Atmospheric Pressure	1019mbar

Test Date : July 14-July 25 2008

Tested By :Choon Sian Ooi

Standard Requirement : 47 CFR §15.247(d)

Procedures: Equipment was setup in a semi-anechoic chamber. For measurements above 1 GHz an average measurement was taken with a 10Hz video bandwidth. The EUT was tested at low, mid and high with the highest output power. Investigated up to 10th harmonic of the operating frequency.

Sample Calculation:

EUT Field Strength = Raw Amplitude(dBµV/m) – Amplifier Gain(dB) + Antenna Factor(dB) + Cable Loss(dB)
+ Filter Attenuation(dB, if used)

Test Result:

Host EUT : QL220

@ 2402MHz @ 3 Meter

Frequency	Reading	Direction	Height	Polar	Antenna Loss	Cable loss	Amplifier	Corrected Reading	15.247/15.209	15.247/15.209	
GHz	(dBuV/m)	Degree	Meter	H / V	(dB)	(dB)	(dB)	(dBuV/m)	Limit (dBuV/m)	Margin	Comments
4.804	43.69	180	155	v	33	4.125	32.49	48.325	74	-25.675	Peak
4.804	49.78	180	155	h	33	4.125	32.49	54.415	74	-19.585	Peak
4.804	32.63	180	155	v	33	4.125	32.49	37.265	54	-16.735	Ave
4.804	40.04	180	155	h	33	4.125	32.49	44.675	54	-9.325	Ave
7.206	38.19	180	155	v	35.5	5.22	32.39	46.52	74	-27.48	Peak
7.206	38.68	180	155	h	35.5	5.22	32.39	47.01	74	-26.99	Peak
7.206	24.21	180	155	v	35.5	5.22	32.39	32.54	54	-21.46	Ave
7.206	24.3	180	155	h	35.5	5.22	32.39	32.63	54	-21.37	Ave
9.608	37.71	180	155	v	39.2	6.255	32.32	50.845	74	-23.155	Peak
9.608	37.29	180	155	h	39.2	6.255	32.32	50.425	74	-23.575	Peak
9.608	23.16	180	155	v	39.2	6.255	32.32	36.295	54	-17.705	Ave
9.608	23.03	180	155	h	39.2	6.255	32.32	36.165	54	-17.835	Ave

Emission was scanned up to 25GHz.

@ 2441MHz @ 3Meter

Frequency	Reading	Direction	Height	Polar	Antenna Loss	Cable loss	Amplifier	Corrected Reading	15.247/15.209	15.247/15.209	
GHz	(dBuV/m)	Degree	Meter	H / V	(dB)	(dB)	(dB)	(dBuV/m)	Limit (dBuV/m)	Margin	Comments
4.88	47.57	180	155	v	33	4.125	32.49	52.205	74	-21.795	Peak
4.88	49.25	180	155	h	33	4.125	32.49	53.885	74	-20.115	Peak
4.88	37.7	180	155	v	33	4.125	32.49	42.335	54	-11.665	Ave
4.88	39.06	180	155	h	33	4.125	32.49	43.695	54	-10.305	Ave
7.32	38.14	180	155	v	35.5	5.22	32.39	46.47	74	-27.53	Peak
7.32	39.41	180	155	h	35.5	5.22	32.39	47.74	74	-26.26	Peak
7.32	24.02	180	155	v	35.5	5.22	32.39	32.35	54	-21.65	Ave
7.32	24.03	180	155	h	35.5	5.22	32.39	32.36	54	-21.64	Ave
9.764	35.62	180	155	v	39.2	6.255	32.32	48.755	74	-25.245	Peak
9.764	37.55	180	155	h	39.2	6.255	32.32	50.685	74	-23.315	Peak
9.764	23.33	180	155	v	39.2	6.255	32.32	36.465	54	-17.535	Ave
9.764	23.37	180	155	h	39.2	6.255	32.32	36.505	54	-17.495	Ave

Emission was scanned up to 25GHz.

@ 2480MHz @ 3Meter

Frequency	Reading	Direction	Height	Polar	Antenna Loss	Cable loss	Amplifier	Corrected Reading	15.247/15.209	15.247/15.209	
GHz	(dBuV/m)	Degree	Meter	H / V	(dB)	(dB)	(dB)	(dBuV/m)	Limit (dBuV/m)	Margin	Comments
4.96	47.6	180	155	v	33	4.125	32.49	52.235	74	-21.765	Peak
4.96	49.72	180	155	h	33	4.125	32.49	54.355	74	-19.645	Peak
4.96	37.84	180	155	v	33	4.125	32.49	42.475	54	-11.525	Ave
4.96	40.13	180	155	h	33	4.125	32.49	44.765	54	-9.235	Ave
7.44	38.03	180	155	v	35.5	5.22	32.39	46.36	74	-27.64	Peak
7.44	37.3	180	155	h	35.5	5.22	32.39	45.63	74	-28.37	Peak
7.44	23.64	180	155	v	35.5	5.22	32.39	31.97	54	-22.03	Ave
7.44	23.52	180	155	h	35.5	5.22	32.39	31.85	54	-22.15	Ave
9.92	37.45	180	155	v	39.2	6.255	32.32	50.585	74	-23.415	Peak
9.92	35.68	180	155	h	39.2	6.255	32.32	48.815	74	-25.185	Peak
9.92	23.37	180	155	v	39.2	6.255	32.32	36.505	54	-17.495	Ave
9.92	23.07	180	155	h	39.2	6.255	32.32	36.205	54	-17.795	Ave

Emission was scanned up to 25GHz.

Band Edge

Channel	Polarity	Detector	Frequency	Result	Limit	Margin
Low Channel	V	Peak	2400	39.33	74	-34.67
Low Channel	H	Peak	2400	42.85	74	-31.15
Low Channel	V	Avg	2400	24.32	54	-29.68
Low Channel	H	Avg	2400	27.69	54	-26.31

Channel	Polarity	Detector	Frequency	Result	Limit	Margin
High Channel	V	Peak	2483.5	46.07	74	-27.93
High Channel	H	Peak	2483.5	50.83	74	-23.17
High Channel	V	Avg	2483.5	30.11	54	-23.89
High Channel	H	Avg	2483.5	34.9	54	-19.1

Host EUT: QL320 PLUS

@ 2402MHz @ 3 Meter

Frequency	Reading	Direction	Height	Polar	Antenna Loss	Cable loss	Amplifier	Corrected Reading	15.247/15.209	15.247/15.209	
GHz	(dBuV/m)	Degree	Meter	H / V	(dB)	(dB)	(dB)	(dBuV/m)	Limit (dBuV/m)	Margin	Comments
4.804	46.67	180	155	v	33	4.125	32.49	51.305	74	-22.695	Peak
4.804	50.49	180	155	h	33	4.125	32.49	55.125	74	-18.875	Peak
4.804	37.48	180	155	v	33	4.125	32.49	42.115	54	-11.885	Ave
4.804	40.49	180	155	h	33	4.125	32.49	45.125	54	-8.875	Ave
7.206	37.23	180	155	v	35.5	5.22	32.39	45.56	74	-28.44	Peak
7.206	36.73	180	155	h	35.5	5.22	32.39	45.06	74	-28.94	Peak
7.206	23.6	180	155	v	35.5	5.22	32.39	31.93	54	-22.07	Ave
7.206	23.12	180	155	h	35.5	5.22	32.39	31.45	54	-22.55	Ave
9.608	37.18	180	155	v	39.2	6.255	32.32	50.315	74	-23.685	Peak
9.608	38.07	180	155	h	39.2	6.255	32.32	51.205	74	-22.795	Peak
9.608	23.57	180	155	v	39.2	6.255	32.32	36.705	54	-17.295	Ave
9.608	23.51	180	155	h	39.2	6.255	32.32	36.645	54	-17.355	Ave

Emission was scanned up to 25GHz.

@ 2441MHz @ 3Meter

Frequency	Reading	Direction	Height	Polar	Antenna Loss	Cable loss	Amplifier	Corrected Reading	15.247/15.209	15.247/15.209	
GHz	(dBuV/m)	Degree	Meter	H / V	(dB)	(dB)	(dB)	(dBuV/m)	Limit (dBuV/m)	Margin	Comments
4.88	47.81	180	155	v	33	4.125	32.49	52.445	74	-21.555	Peak
4.88	52.05	180	155	h	33	4.125	32.49	56.685	74	-17.315	Peak
4.88	37.58	180	155	v	33	4.125	32.49	42.215	54	-11.785	Ave
4.88	40.93	180	155	h	33	4.125	32.49	45.565	54	-8.435	Ave
7.32	38.88	180	155	v	35.5	5.22	32.39	47.21	74	-26.79	Peak
7.32	37.8	180	155	h	35.5	5.22	32.39	46.13	74	-27.87	Peak
7.32	23.93	180	155	v	35.5	5.22	32.39	32.26	54	-21.74	Ave
7.32	23.87	180	155	h	35.5	5.22	32.39	32.2	54	-21.8	Ave
9.764	37.7	180	155	v	39.2	6.255	32.32	50.835	74	-23.165	Peak
9.764	38	180	155	h	39.2	6.255	32.32	51.135	74	-22.865	Peak
9.764	23.23	180	155	v	39.2	6.255	32.32	36.365	54	-17.635	Ave
9.764	23.21	180	155	h	39.2	6.255	32.32	36.345	54	-17.655	Ave

Emission was scanned up to 25GHz.

@ 2480MHz @ 3Meter

Frequency	Reading	Direction	Height	Polar	Antenna Loss	Cable loss	Amplifier	Corrected Reading	15.247/15.209	15.247/15.209	
GHz	(dBuV/m)	Degree	Meter	H / V	(dB)	(dB)	(dB)	(dBuV/m)	Limit (dBuV/m)	Margin	Comments
4.96	49.68	180	155	v	33	4.125	32.49	54.315	74	-19.685	Peak
4.96	51.66	180	155	h	33	4.125	32.49	56.295	74	-17.705	Peak
4.96	38.55	180	155	v	33	4.125	32.49	43.185	54	-10.815	Ave
4.96	41.44	180	155	h	33	4.125	32.49	46.075	54	-7.925	Ave
7.44	36.89	180	155	v	35.5	5.22	32.39	45.22	74	-28.78	Peak
7.44	38.06	180	155	h	35.5	5.22	32.39	46.39	74	-27.61	Peak
7.44	23.38	180	155	v	35.5	5.22	32.39	31.71	54	-22.29	Ave
7.44	23.3	180	155	h	35.5	5.22	32.39	31.63	54	-22.37	Ave
9.92	37.78	180	155	v	39.2	6.255	32.32	50.915	74	-23.085	Peak
9.92	36.69	180	155	h	39.2	6.255	32.32	49.825	74	-24.175	Peak
9.92	23.29	180	155	v	39.2	6.255	32.32	36.425	54	-17.575	Ave
9.92	23.35	180	155	h	39.2	6.255	32.32	36.485	54	-17.515	Ave

Emission was scanned up to 25GHz.

Band Edge

Channel	Polarity	Detector	Frequency	Result	Limit	Margin
Low Channel	V	Peak	2400	39.29	74	-34.71
Low Channel	H	Peak	2400	42.47	74	-31.53
Low Channel	V	Avg	2400	24.2	54	-29.8
Low Channel	H	Avg	2400	26.95	54	-27.05

Channel	Polarity	Detector	Frequency	Result	Limit	Margin
High Channel	V	Peak	2483.5	46.04	74	-27.96
High Channel	H	Peak	2483.5	50.17	74	-23.83
High Channel	V	Avg	2483.5	31.21	54	-22.79
High Channel	H	Avg	2483.5	34.84	54	-19.16

Host EUT: QL420 PLUS

@ 2402MHz @ 3 Meter

Frequency	Reading	Direction	Height	Polar	Antenna Loss	Cable loss	Amplifier	Corrected Reading	15.247/15.209	15.247/15.209	
GHz	(dBuV/m)	Degree	Meter	H / V	(dB)	(dB)	(dB)	(dBuV/m)	Limit (dBuV/m)	Margin	Comments
4.804	46.28	180	155	v	33	4.125	32.49	50.915	74	-23.085	Peak
4.804	48.53	180	155	h	33	4.125	32.49	53.165	74	-20.835	Peak
4.804	37.74	180	155	v	33	4.125	32.49	42.375	54	-11.625	Ave
4.804	38.71	180	155	h	33	4.125	32.49	43.345	54	-10.655	Ave
7.206	37.77	180	155	v	35.5	5.22	32.39	46.1	74	-27.9	Peak
7.206	38.48	180	155	h	35.5	5.22	32.39	46.81	74	-27.19	Peak
7.206	23.45	180	155	v	35.5	5.22	32.39	31.78	54	-22.22	Ave
7.206	23.57	180	155	h	35.5	5.22	32.39	31.9	54	-22.1	Ave
9.608	37.71	180	155	v	39.2	6.255	32.32	50.845	74	-23.155	Peak
9.608	38.31	180	155	h	39.2	6.255	32.32	51.445	74	-22.555	Peak
9.608	23.4	180	155	v	39.2	6.255	32.32	36.535	54	-17.465	Ave
9.608	23.45	180	155	h	39.2	6.255	32.32	36.585	54	-17.415	Ave

Emission was scanned up to 25GHz.

@ 2441MHz @ 3Meter

Frequency	Reading	Direction	Height	Polar	Antenna Loss	Cable loss	Amplifier	Corrected Reading	15.247/15.209	15.247/15.209	
GHz	(dBuV/m)	Degree	Meter	H / V	(dB)	(dB)	(dB)	(dBuV/m)	Limit (dBuV/m)	Margin	Comments
4.88	45.33	180	155	v	33	4.125	32.49	49.965	74	-24.035	Peak
4.88	47.41	180	155	h	33	4.125	32.49	52.045	74	-21.955	Peak
4.88	34.48	180	155	v	33	4.125	32.49	39.115	54	-14.885	Ave
4.88	37.25	180	155	h	33	4.125	32.49	41.885	54	-12.115	Ave
7.32	37.73	180	155	v	35.5	5.22	32.39	46.06	74	-27.94	Peak
7.32	37.58	180	155	h	35.5	5.22	32.39	45.91	74	-28.09	Peak
7.32	23.47	180	155	v	35.5	5.22	32.39	31.8	54	-22.2	Ave
7.32	23.38	180	155	h	35.5	5.22	32.39	31.71	54	-22.29	Ave
9.764	37.75	180	155	v	39.2	6.255	32.32	50.885	74	-23.115	Peak
9.764	37.74	180	155	h	39.2	6.255	32.32	50.875	74	-23.125	Peak
9.764	23.31	180	155	v	39.2	6.255	32.32	36.445	54	-17.555	Ave
9.764	23.36	180	155	h	39.2	6.255	32.32	36.495	54	-17.505	Ave

Emission was scanned up to 25GHz.

@ 2480MHz @ 3Meter

Frequency	Reading	Direction	Height	Polar	Antenna Loss	Cable loss	Amplifier	Corrected Reading	15.247/15.209	15.247/15.209	
GHz	(dBuV/m)	Degree	Meter	H / V	(dB)	(dB)	(dB)	(dBuV/m)	Limit (dBuV/m)	Margin	Comments
4.96	44.19	180	155	v	33	4.125	32.49	48.825	74	-25.175	Peak
4.96	48.28	180	155	h	33	4.125	32.49	52.915	74	-21.085	Peak
4.96	30.95	180	155	v	33	4.125	32.49	35.585	54	-18.415	Ave
4.96	38.11	180	155	h	33	4.125	32.49	42.745	54	-11.255	Ave
7.44	37.53	180	155	v	35.5	5.22	32.39	45.86	74	-28.14	Peak
7.44	37.18	180	155	h	35.5	5.22	32.39	45.51	74	-28.49	Peak
7.44	23.34	180	155	v	35.5	5.22	32.39	31.67	54	-22.33	Ave
7.44	23.12	180	155	h	35.5	5.22	32.39	31.45	54	-22.55	Ave
9.92	37.72	180	155	v	39.2	6.255	32.32	50.855	74	-23.145	Peak
9.92	37.12	180	155	h	39.2	6.255	32.32	50.255	74	-23.745	Peak
9.92	23.89	180	155	v	39.2	6.255	32.32	37.025	54	-16.975	Ave
9.92	23.12	180	155	h	39.2	6.255	32.32	36.255	54	-17.745	Ave

Emission was scanned up to 25GHz.

Band Edge

Channel	Polarity	Detector	Frequency	Result	Limit	Margin
Low Channel	V	Peak	2400	39.92	74	-34.08
Low Channel	H	Peak	2400	42.81	74	-31.19
Low Channel	V	Avg	2400	24.81	54	-29.19
Low Channel	H	Avg	2400	26.15	54	-27.85

Channel	Polarity	Detector	Frequency	Result	Limit	Margin
High Channel	V	Peak	2483.5	46.49	74	-27.51
High Channel	H	Peak	2483.5	49.83	74	-24.17
High Channel	V	Avg	2483.5	31.92	54	-22.08
High Channel	H	Avg	2483.5	34.03	54	-19.97

Annex A. TEST INSTRUMENT & METHOD

Annex A.i. TEST INSTRUMENTATION & GENERAL PROCEDURES

Instrument	Manufacturer	Model	CAL Due Date
Spectrum Analyzer	HP	8564E	04/26/2009
EMI Receiver	Rohde & Schwarz	ESIB 40	4/25/2009
R&S LISN	R&S	ESH2-Z5	04/24/2009
CHASE LISN	Chase	MN2050B	04/24/2009
Antenna(1 ~18GHz)	Emco	3115	10/04/2008
Antenna (30MHz~2GHz)	Sunol Sciences	JB1	10/04/2008
Chamber	Lingren	3m	04/18/2009
Pre-Amplifier(1 ~ 26GHz)	HP	8449	04/24/2009
Horn Antenna (18~40GHz)	Com Power	AH-840	5/21/2009
Microwave Pre-Amp (18~40GHz)	Com Power	PA-840	5/21/2009

Note: No calibration required.

Annex A.ii. CONDUCTED EMISSIONS TEST DESCRIPTION

Test Set-up

1. The EUT and supporting equipment were set up in accordance with the requirements of the standard on top of a 1.5m x 1m x 0.8m high, non-metallic table, as shown in Annex B.
2. The power supply for the EUT was fed through a 50Ω/50μH EUT LISN, connected to filtered mains.
3. The RF OUT of the EUT LISN was connected to the EMI test receiver via a low-loss coaxial cable.
4. All other supporting equipments were powered separately from another main supply.

Test Method

1. The EUT was switched on and allowed to warm up to its normal operating condition.
2. A scan was made on the NEUTRAL line (for AC mains) or Earth line (for DC power) over the required frequency range using an EMI test receiver.
3. High peaks, relative to the limit line, were then selected.
4. The EMI test receiver was then tuned to the selected frequencies and the necessary measurements made with a receiver bandwidth setting of 10 KHz. For FCC tests, only Quasi-peak measurements were made; while for CISPR/EN tests, both Quasi-peak and Average measurements were made.
5. Steps 2 to 4 were then repeated for the LIVE line (for AC mains) or DC line (for DC power).

Sample Calculation Example

At 20 MHz	limit = 250 μV = 47.96 dBμV
Transducer factor of LISN, pulse limiter & cable loss at 20 MHz = 11.20 dB	
Q-P reading obtained directly from EMI Receiver = 40.00 dBμV (Calibrated for system losses)	
Therefore, Q-P margin = 47.96 – 40.00 = 7.96	i.e. 7.96 dB below limit

Annex A. iii RADIATED EMISSIONS TEST DESCRIPTION

EUT Characterisation

EUT characterisation, over the frequency range from 30MHz to 10th Harmonic , was done in order to minimise radiated emissions testing time while still maintaining high confidence in the test results.

The EUT was placed in the chamber, at a height of about 0.8m on a turntable. Its radiated emissions frequency profile was observed, using a spectrum analyzer /receiver with the appropriate broadband antenna placed 3m away from the EUT. Radiated emissions from the EUT were maximised by rotating the turntable manually, changing the antenna polarisation and manipulating the EUT cables while observing the frequency profile on the spectrum analyzer / receiver. Frequency points at which maximum emissions occurred, clock frequencies and operating frequencies were then noted for the formal radiated emissions test at the Open Area Test Site (OATS).

Test Set-up

1. The EUT and supporting equipment were set up in accordance with the requirements of the standard on top of a 1.5m X 1.0m X 0.8m high, non-metallic table.
2. The filtered power supply for the EUT and supporting equipment were tapped from the appropriate power sockets located on the turntable.
3. The relevant broadband antenna was set at the required test distance away from the EUT and supporting equipment boundary.

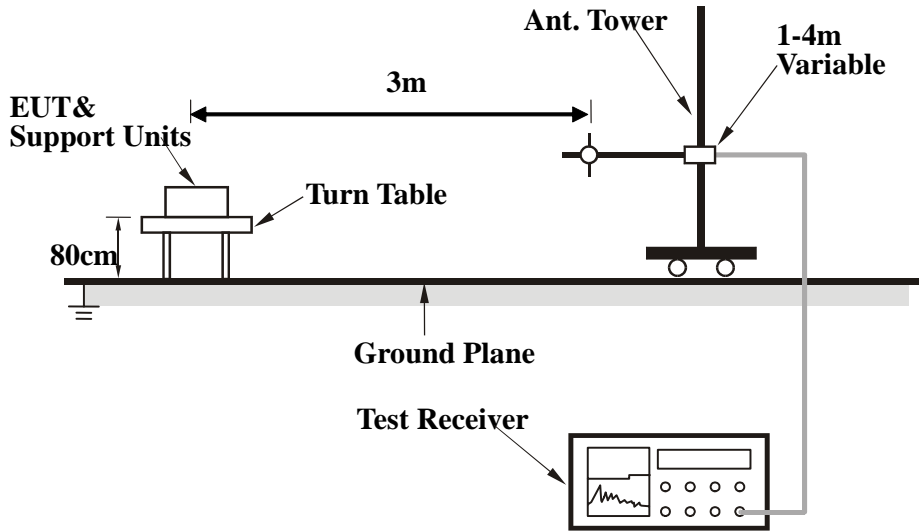

Test Method

The following procedure was performed to determine the maximum emission axis of EUT:

1. With the receiving antenna is H polarization, rotate the EUT in turns with three orthogonal axes to determine the axis of maximum emission.
2. With the receiving antenna is V polarization, rotate the EUT in turns with three orthogonal axes to determine the axis of maximum emission.
3. Compare the results derived from above two steps. So, the axis of maximum emission from EUT was determined and the configuration was used to perform the final measurement.

Final Radiated Emission Measurement

1. Setup the configuration according to figure 1. Turn on EUT and make sure that it is in normal function.
2. For emission frequencies measured below 1 GHz, a pre-scan is performed in a shielded chamber to determine the accurate frequencies of higher emissions will be checked on a open test site. As the same purpose, for emission frequencies measured above 1 GHz, a pre-scan also be performed with a 1 meter measuring distance before final test.
3. For emission frequencies measured below and above 1 GHz, set the spectrum analyzer on a 100 kHz and 1 MHz resolution bandwidth respectively for each frequency measured in step 2.
4. The search antenna is to be raised and lowered over a range from 1 to 4 meters in horizontally polarized orientation. Position the highness when the highest value is indicated on spectrum analyzer, then change the orientation of EUT on test table over a range from 0 ° to 360 ° with a speed as slow as possible, and keep the azimuth that highest emission is indicated on the spectrum analyzer. Vary the antenna position again and record the highest value as a final reading.
5. Repeat step 4 until all frequencies need to be measured were complete.
6. Repeat step 5 with search antenna in vertical polarized orientations.

During the radiated emission test, the Spectrum Analyzer was set with the following configurations:

Frequency Band (MHz)	Function	Resolution bandwidth	Video Bandwidth
30 to 1000	Peak	100 kHz	100 kHz
Above 1000	Peak	1 MHz	1 MHz
	Average	1 MHz	10 Hz

Sample Calculation Example

The field strength is calculated by adding the Antenna Factor and Cable Factor, and subtracting the Amplifier Gain (if any) from the measured reading. For the limit is employed average value, therefore the peak value can be transferred to average value by subtracting the duty factor. The basic equation with a sample calculation is as follows:

$$\text{Peak} = \text{Reading} + \text{Corrected Factor}$$

where

$$\text{Corr. Factor} = \text{Antenna Factor} + \text{Cable Factor} - \text{Amplifier Gain (if any)}$$

And the average value is

$$\text{Average} = \text{Peak Value} + \text{Duty Factor or}$$

$$\text{Set RBW} = 1\text{MHz, VBW} = 10\text{Hz.}$$

Note :

If the measured frequencies are fall in the restricted frequency band, the limit employed must be quasi peak value when frequencies are below or equal to 1 GHz. And the measuring instrument is set to quasi peak detector function.

Annex B EUT AND TEST SETUP PHOTOGRAPHS

Please see the attachment

Annex C. TEST SETUP AND SUPPORTING EQUIPMENT

EUT TEST CONDITIONS

Annex C. i. SUPPORTING EQUIPMENT DESCRIPTION

The following is a description of supporting equipment and details of cables used with the EUT.

Equipment Description (Including Brand Name)	Model & Serial Number	Cable Description (List Length, Type & Purpose)
Laptop PC	Dell	Serial cable, USB cable: 1 meter.

Block Configuration Diagram for Radiated Emission

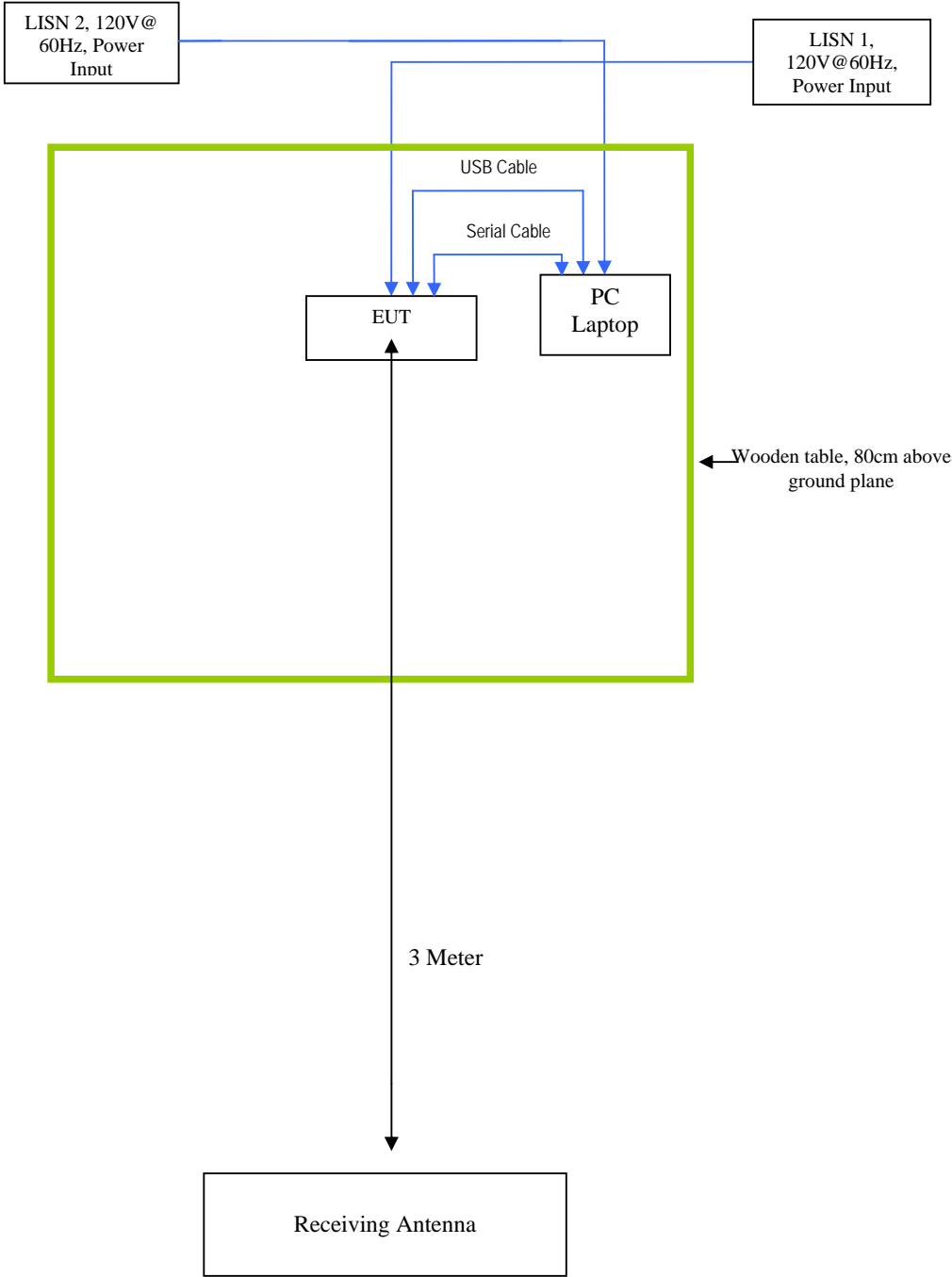

Block Configuration Diagram for Conducted Emission

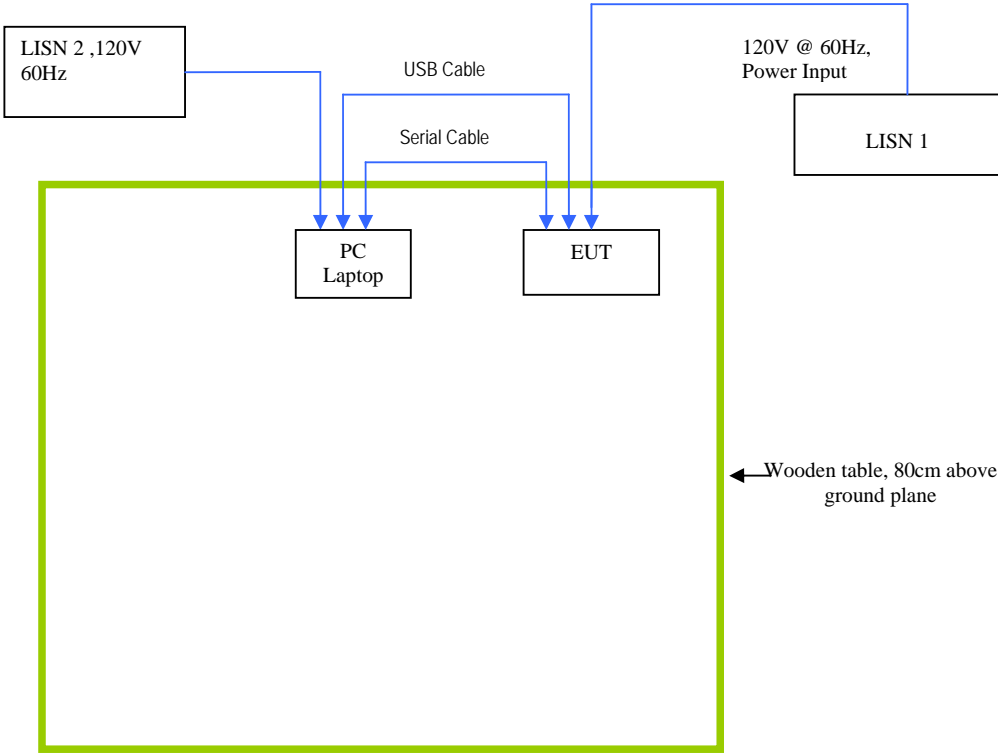

Annex C.ii. EUT OPERATING CONDITIONS

The following is the description of how the EUT is exercised during testing.

Test	Description Of Operation
Emissions Testing	The EUT was controlled via PC Using manufacturer's program.
Others Testing	TX mode is normal mode with full power.

Annex D USER MANUAL, BLOCK & CIRCUIT DIAGRAM

Please see attachment