

ROK 101 007 Bluetooth Module

Key Features

- Pre-qualified Bluetooth 1.0B Module
- RF output power class 2
- FCC and ETSI approved
- 460 kb/s max data rate over UART
- Multiple interface for different applications
 - UART for data
 - PCM for voice
 - USB for voice and data
- I²C interface
- Internal crystal oscillator
- HCI firmware included
- Multi Point Operation
- Built-in shielding

Suggested Applications

- Computers and peripherals
- Handheld devices and accessories
- Access points

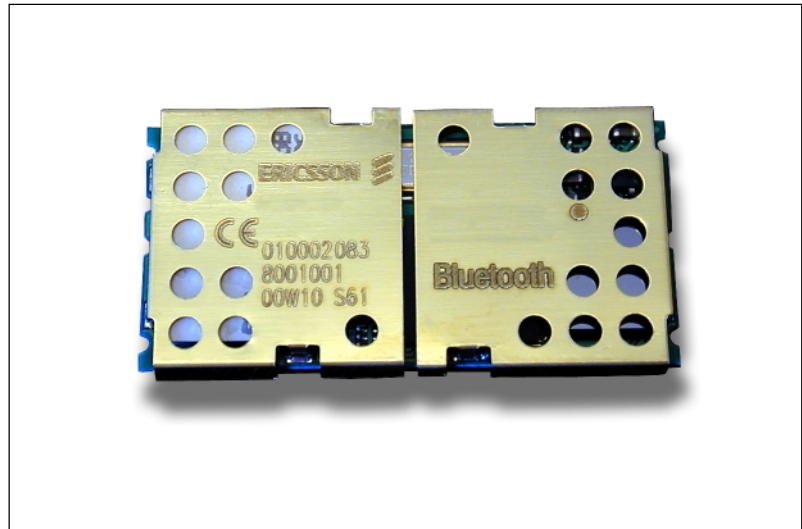

Description

ROK 101 007 is a short-range module for implementing Bluetooth functionality into various electronic devices. The module consists of three major parts; a baseband controller, a flash memory, and a radio that operates in the globally available 2.4–2.5 GHz free ISM band.

Both data and voice transmission is supported by the module. Communication between the module and the host controller is carried out using a high-speed USB interface compliant with USB Specifications 1.1 or an UART/PCM interface. When using the USB interface, the module appears as a USB slave device and therefore requires no PC resources.

ROK 101 007, which is compliant with Bluetooth version 1.0B, is a Class 2 Bluetooth Module (0 dBm) and is type-approved. The module supports all Bluetooth profiles.

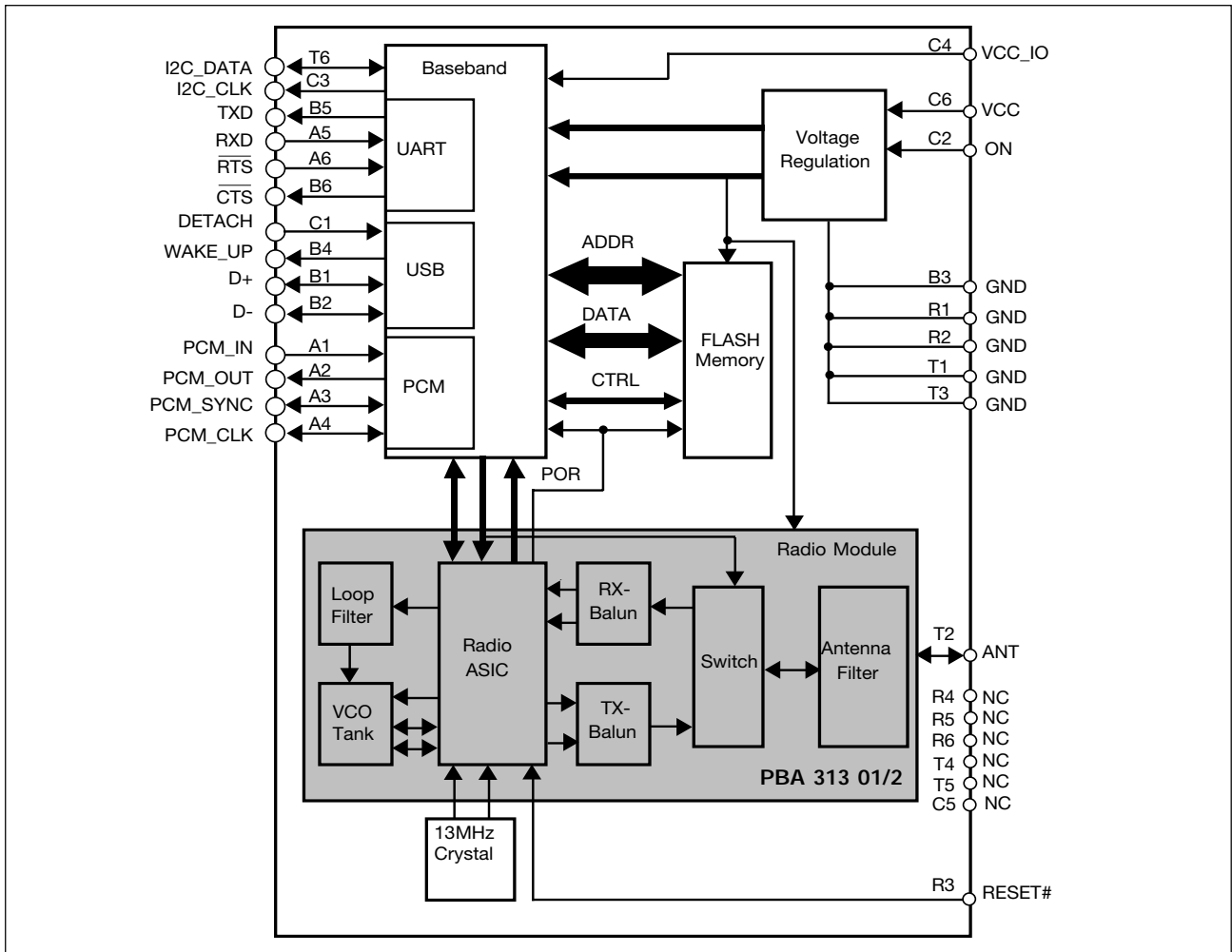

Figure 1. Block Diagram

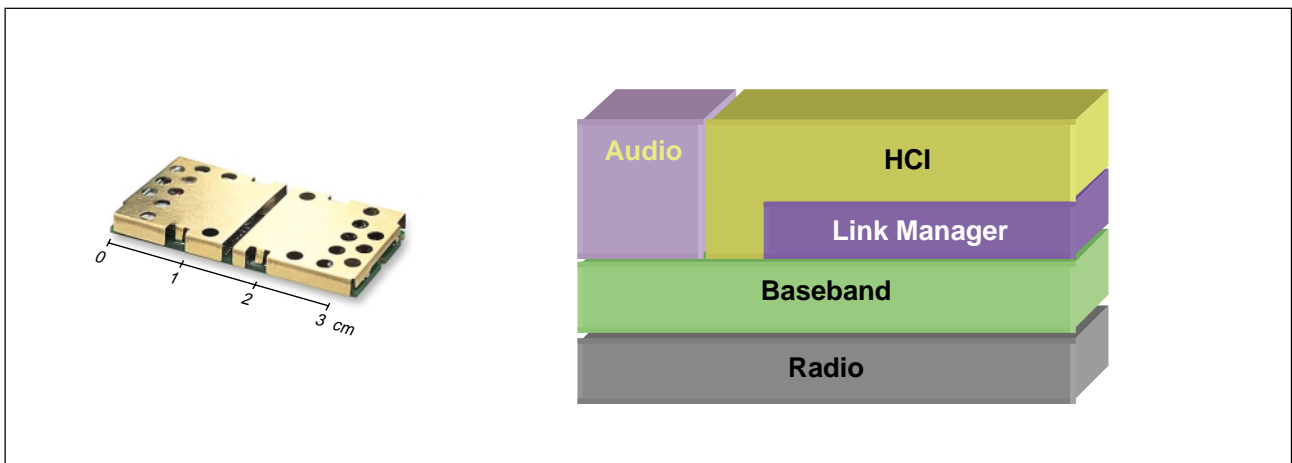

Figure 2. Actual size of the Ericsson Bluetooth Module, and also showing the HW and FW stack.

Absolute Maximum Ratings

Parameter	Symbol	Min	Typ	Max	Unit
Temperature					
Storage temperature	T_{Stg}	-30		+85	°C
Operating temperature	T_{Amb}	0		+75	°C
Power Supply					
V_{CC}	V_{CC}	-0.3		+5.25	V
V_{CC_IO}	V_{CC_IO}	-0.8		+3.6	V
Digital Inputs					
Input low voltage	V_{IL}	-0.5			V
Input high voltage	V_{IH}			$V_{CC_IO} + 0.3$	V

Recommended Operating Conditions

Temperature					
Ambient temperature, Test	T_{amb}		+23		°C
Power Supply					
Positive Supply Voltage	V_{CC}		+3.3		V
I/O Ports Supply Voltage	V_{CC_IO}		+3.3		V

Electrical Characteristics
DC Specifications

Unless otherwise noted, the specification applies for $T_{Amb} = 0$ to $+75^{\circ}\text{C}$, $3.175 < V_{CC} < 5.25\text{V}$

Parameter	Condition	Symbol	Min	Typ	Max	Unit
Power Supply						
Supply Voltage		V_{CC}	3.175	3.3	5.25	V
I/O Ports Supply Voltage	See note 10	V_{CC_IO}	2.7	3.3	3.6	V
Digital Inputs						
Logical Input High	Except ON signal	V_{IH1}	$0.7 \times V_{CC_IO}$		V_{CC_IO}	V
Logical Input Low	Except ON signal	V_{IL2}	0		$0.3 \times V_{CC_IO}$	V
Logical Input High	ON signal only	V_{IH2}	2.0		V_{CC}	V
Logical Input Low	ON signal only	V_{IL2}	0		0.4	V
Digital Outputs						
Logical Output High		V_{OH}	$0.9 \times V_{CC_IO}$		V_{CC_IO}	V
Logical Output Low		V_{OL}	0		$0.1 \times V_{CC_IO}$	V

Parameter	Condition	Symbol	Min	Typ	Max	Unit
Average Current Consumption						
Average $I_{CC} + I_{CC,IO}$						
Standby		I_{STA}		5.95		mA
Shutdown - SW		I_{SSW}		2.35		mA
Shutdown - HW	See note 1	I_{SHW}		1		μ A
Page Scan Mode R0	Page Scan Enable Page scan window: continuous Page scan interval : n/a (0s)	I_{PSM1}		50		mA
Page Scan Mode R1	Page Scan Enable Page scan window: 11.25ms Page scan interval : 1.28s	I_{PSM2}		6.35		mA
Page Scan Mode R2	Page Scan Enable Page scan window: 11.25ms Page scan interval : 2.56s	I_{PSM3}		6.15		mA
Inquiry Scan with Page Scan Mode R0.	Inquiry Scan Enable Page Scan Window : 2.56s –11.25ms Page Scan Interval : 2.56s Inquiry Scan Window : 11.25ms Inquiry Scan Interval : 2.56s	I_{ISM1}		50		mA
Inquiry Scan with Page Scan Mode R1.	Inquiry Scan Enable Page Scan Window : 11.25ms Page Scan Interval : 1.28s Inquiry Scan Window : 11.25ms Inquiry Scan Interval : 2.56s	I_{ISM2}		6.55		mA
Inquiry Scan with Page Scan Mode R2.	Inquiry Scan Enable Page Scan Window : 11.25ms Page Scan Interval : 2.56s Inquiry Scan Window : 11.25ms Inquiry Scan Interval : 2.56s	I_{ISM3}		6.35		mA
Connect State	Established connection with data transfer	I_{CS}		26		mA
$V_{CC,IO}$ Current	Only $I_{CC,IO}$, $V_{CC,IO}=TBD$	$I_{CC,IO}$		TBD		mA

RF Specifications

Parameter	Condition	Symbol	Min	Typ	Max	Unit
General						
Frequency Range			2.402		2.480	GHz
Double Sided IF Bandwidth				1		MHz
Antenna load				50		Ω
VSWR	RX mode			3:1		
VSWR	TX mode, see note 2			3:1		
Receive Performance						
Sensitivity level	P_{IN} : -70dBm, 75kHz offset (max),				0.1%	BER
Max input level	P_{IN} : -20dBm, 75kHz offset (max),				0.1%	BER
C/I co-channel	C: -60 dBm				14	dB
C/I 1MHz	C: -60 dBm				+4	dB
C/I 2MHz	C: -60 dBm				-30	dB
C/I ≥ 3 MHz	C: -67 dBm				-40	dB
Blocking, $C/I_{DC-5GHz}$	See figure 6					
Out-of-band blocking	30-1910 MHz		+4			dBm
	1910-2000 MHz		-10			dBm
	2000-2399 MHz		-27			dBm
	2484-3000 MHz		-27			dBm
	3.00-12.75 GHz		-10			dBm
Spurious Emissions	30 MHz to 1 GHz				-57	dBm
Spurious Emissions	1 GHz to 12.75 GHz				-47	dBm
Transmitter Performance						
Frequency deviation	see notes 3,4 and figure 3	f_{Mod}	140		175	kHz
Initial frequency error	see note 5		-48		+48	kHz
TX power			-2	1.5	4	dBm
TX carrier drift in 1 slot (366 μ s)		f_{Drift1}	-25		25	kHz
TX carrier drift in 3 slots (1598 μ s)		f_{Drift2}	-40		40	kHz
TX carrier drift in 5 slots (2862 μ s)	see figure 4	f_{Drift3}	-40		40	kHz
20 dB bandwidth	Measured with RBW: 10 kHz and peak detector				1.000	MHz
Spurious Emissions	30 MHz – 1GHz				-36	dBm
Spurious Emissions	1 GHz – 12.75 GHz				-30	dBm
Spurious Emissions	1.8 Hz – 1.9 GHz				-47	dBm
Spurious Emissions	5.15 GHz – 5.3 GHz				-47	dBm
Timing performance						
LPO_CLK frequency	Trimmed, see note 6	$f_{LPO-CLK}$		3,2		kHz
Tolerance of LPO_CLK	see note 6		-250		+250	ppm
System clock frequency		$f_{SYS-CLK}$		13.0000		MHz
Tolerance of system clock	see note 5		-20		+20	ppm
Channel switching time	see figure 5			150		μ s
Received Signal Strength Indicator						
RSSI	Input power = -40 dBm		15		25	n/a
RSSI	Input power = -60 dBm		3		11	n/a

RF Specifications continued...

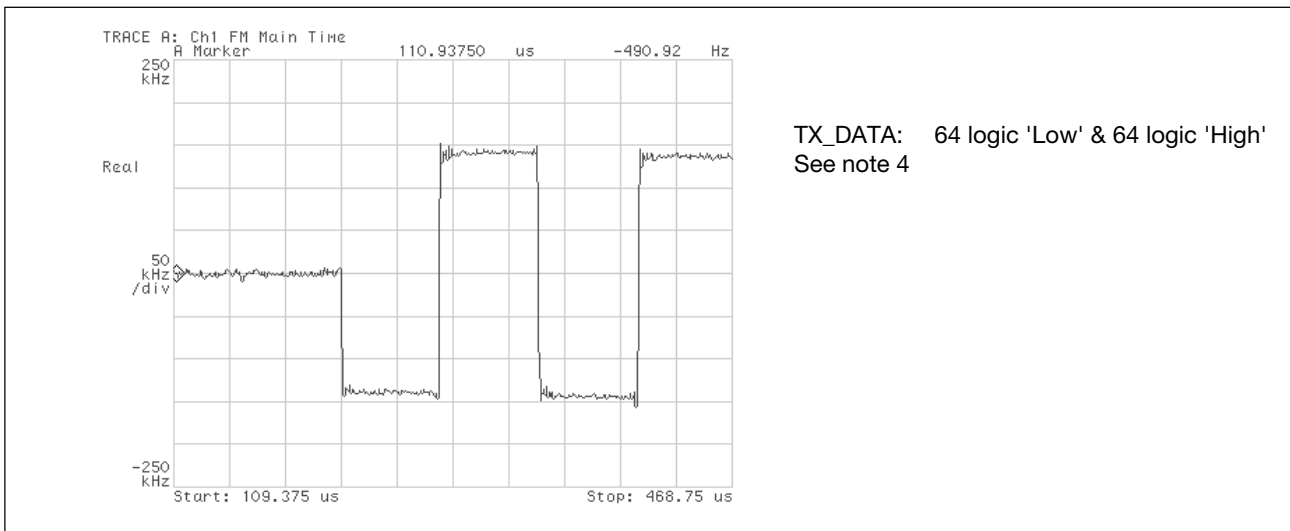

Figure 3. Frequency Deviation

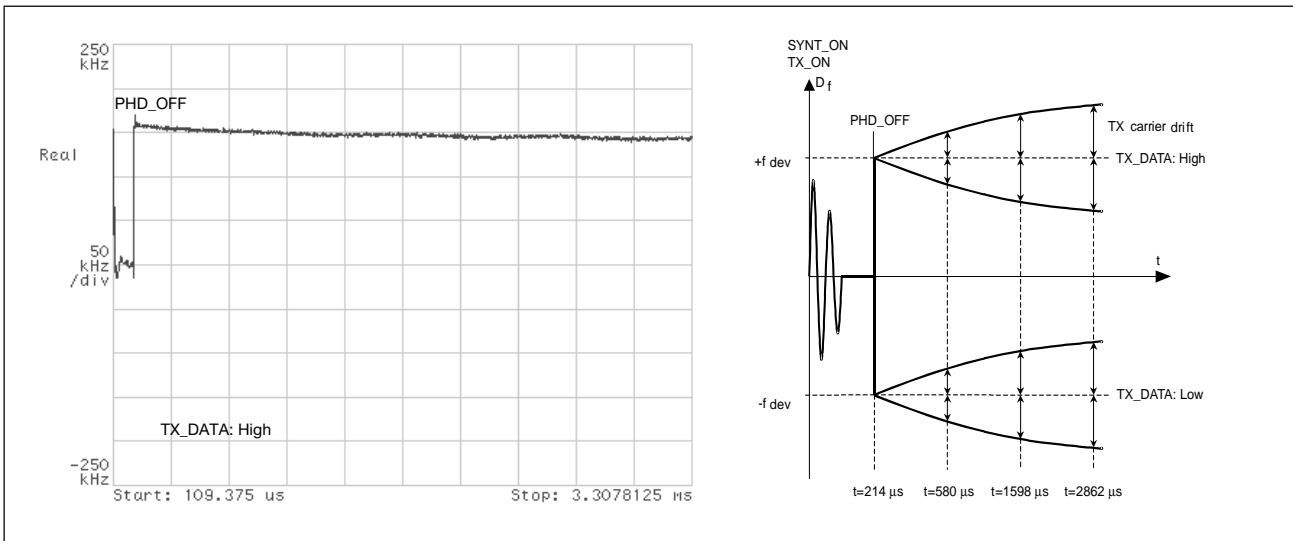

Figure 4. Frequency drift.

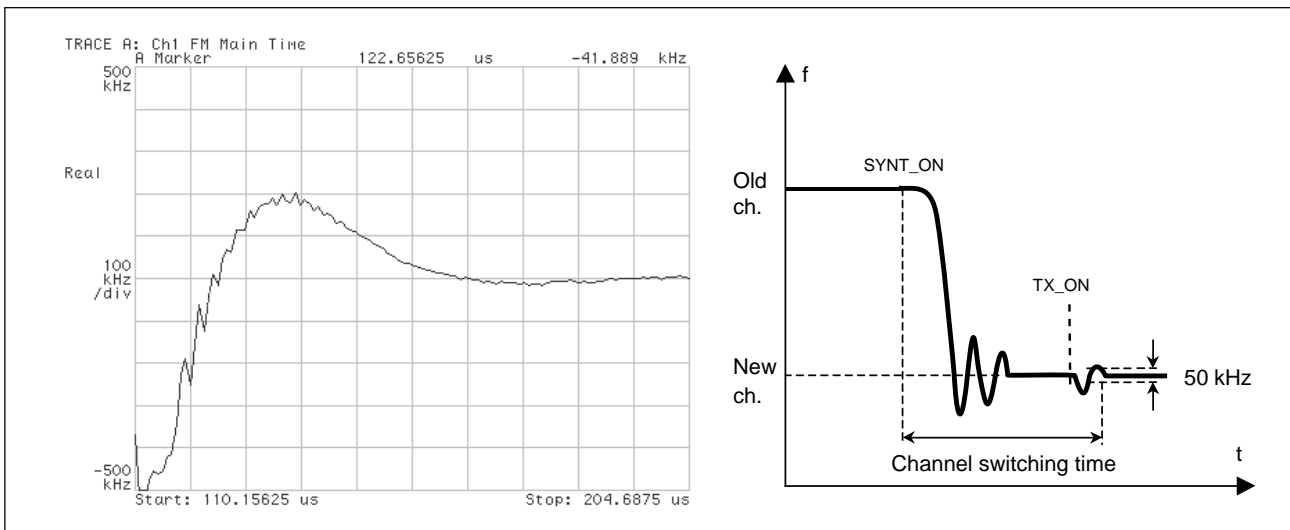

Figure 5. Channel switching time

RF Specifications continued...

C/I Blocking

The blocking characteristics can be basically split into two regions: In-band and Out-of-band. Blocking is performed both on the chip and on the module level.

- **In-band**
 - Filtering on chip
 - C/I @ 2MHz: -30 dB -> 0.1%BER
 - C/I ≥ 3MHz: -40 dB -> 0.1%BER
- **Out-of-band**
 - Antenna filter, DC to 1.9 GHz and 3:rd harmonic.
 - Switch, low freq. and 2:nd harmonic.
 - RX-balun, low freq. and 2:nd harmonic.
 - On-chip IF filter

Figure 6 shows the combination blocking effect of the antenna switch, antenna filter and RX balun. In addition to the blocking characteristics shown in figure 6, there is antenna isolation and filtering on the chip.

Marker 1 shows the region where the Bluetooth band is located. Markers 2 - 4 show the blocking at the telecom frequency bands.

An example of the total blocking characteristics can be seen in figure 7.

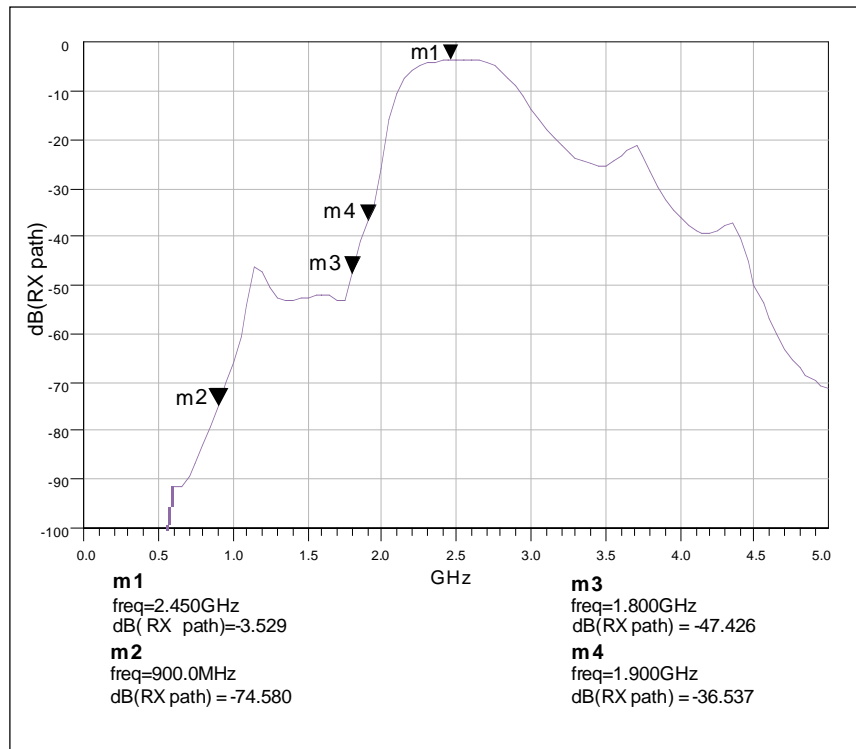

Figure 6. Typical blocking characteristics excluding antenna isolation and on chip filtering.

Example 1		Example 2	
Interference of +33 dBm at 2015 MHz.		Interference of +33 dBm at 1910 MHz.	
• Antenna isolation	15 dB	• Antenna isolation	25 dB
• Antenna filter, Antenna switch, RX-balun	27 dB	• Antenna filter, Antenna switch, RX-balun	36 dB
• Interference level before IF filter +33-15-27=	-9 dBm	• Interference level before IF filter +33-25-36=	-28 dBm
0.1% BER requires a C/I of more than -40 dB at the IF filter.			
• 0.1% BER carrier level -40 + (-9)=	-49 dBm	• 0.1% BER carrier level -40 + (-28)=	-68 dBm

Figure 7. Blocking examples.

Pin Description				
Pin	Pin Name	Type	Direction	Description
A1	PCM_IN	CMOS	In	PCM data, see notes 7,9
A2	PCM_OUT	CMOS	Out	PCM data, see notes 7,9
A3	PCM_SYNC	CMOS	In/Out	Sets the PCM data sampling rate, see notes 7,9
A4	PCM_CLK	CMOS	In/Out	PCM clock that sets the PCM data rate, see notes 7,9
A5	RXD	CMOS	Input	RX data to the UART, see note 9
A6	RTS	CMOS	Input	Flow control signal, Request To Send data from UART, see notes 7,9
B1	D+	CMOS	In/Out	USB data pin, see notes 9,10
B2	D-	CMOS	In/Out	USB data pin, see notes 9,10
B3	GND	Power	Power	Signal ground
B4	WAKE_UP	CMOS	Output	Indicates that the module wants to be attached to the USB, Active High. See notes 9,10
B5	TXD	CMOS	Output	TX data from the UART, see note 9
B6	CTS	CMOS	Output	Flow control signal, Clear To Send data from UART, see note 9
C1	DETACH	CMOS	Input	Indicates that the USB host wants to detach the module, Active High. See notes 7,9
C2	ON	Power	Input	When tied to V_{CC} , the module is enabled.
C3	I2C_CLK	CMOS	Output	I2C clock signal, see note 9
C4	VCC_IO	Power	Power	External supply rail to the Input / Output ports
C5	NC	-	-	Do not connect
C6	VCC	Power	Power	Supply Voltage
R1	GND	Power	Power	Signal ground
R2	GND	Power	Power	Signal ground
R3	RESET#	CMOS	Input	Active low reset, see notes 8,9
R4	NC	-	-	Do not connect
R5	NC	-	-	Do not connect
R6	NC	-	-	Do not connect
T1	GND	Power	Power	Signal Ground
T2	ANT	RF	In/Out	50 Ω Antenna connection
T3	GND	Power	Power	Signal Ground
T4	NC	Power	Power	Test point, internal voltage regulator - Do not connect
T5	NC	-	-	Do not connect
T6	I2C_DATA	CMOS	In/Out	I2C data signal, see note 9

Notes

1. Current consumption is based upon when the module is when 'ON' is low and 'VCC_IO' is grounded.
2. During the TX mode, the VSWR specification states the limits that are acceptable before any other RF parameters are strongly effected, i.e. frequency deviation and initial frequency error.
3. Frequency deviation measurements are now recorded differentially, $(f \text{ Mod1} - f \text{ Mod0}) / 2$.
4. Provided that the TX INV register (bit 0) has been set in the enable register at startup.
5. Tolerance for the system clock takes into account both the complete temperature range and aging of the crystal.
6. LPO_CLK frequency is pre-trimmed within a tolerance of ± 250 ppm.
7. 100k Ω pull-up resistors to V_{CC_IO} are used on the module. PCM signals direction is programmable
8. RESET# signal must be fed from an open drain output.
9. CMOS buffers are low voltage TTL compatible signals.
10. To be compliant with the USB specification, $VCC_IO \geq 3.11V$

Mechanical Specification

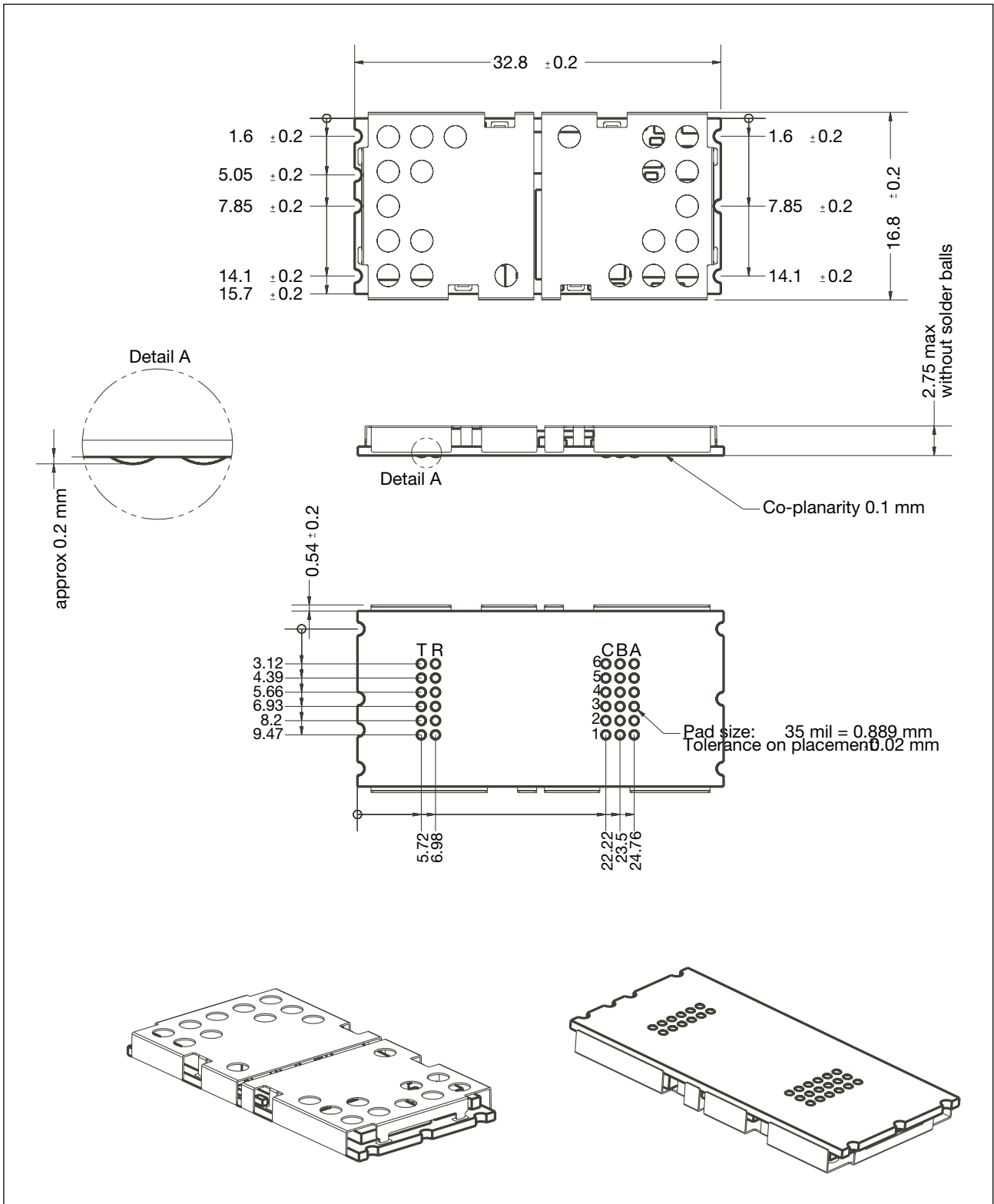

Figure 8. Mechanical dimensions.

Application Block Schematics

USB Application

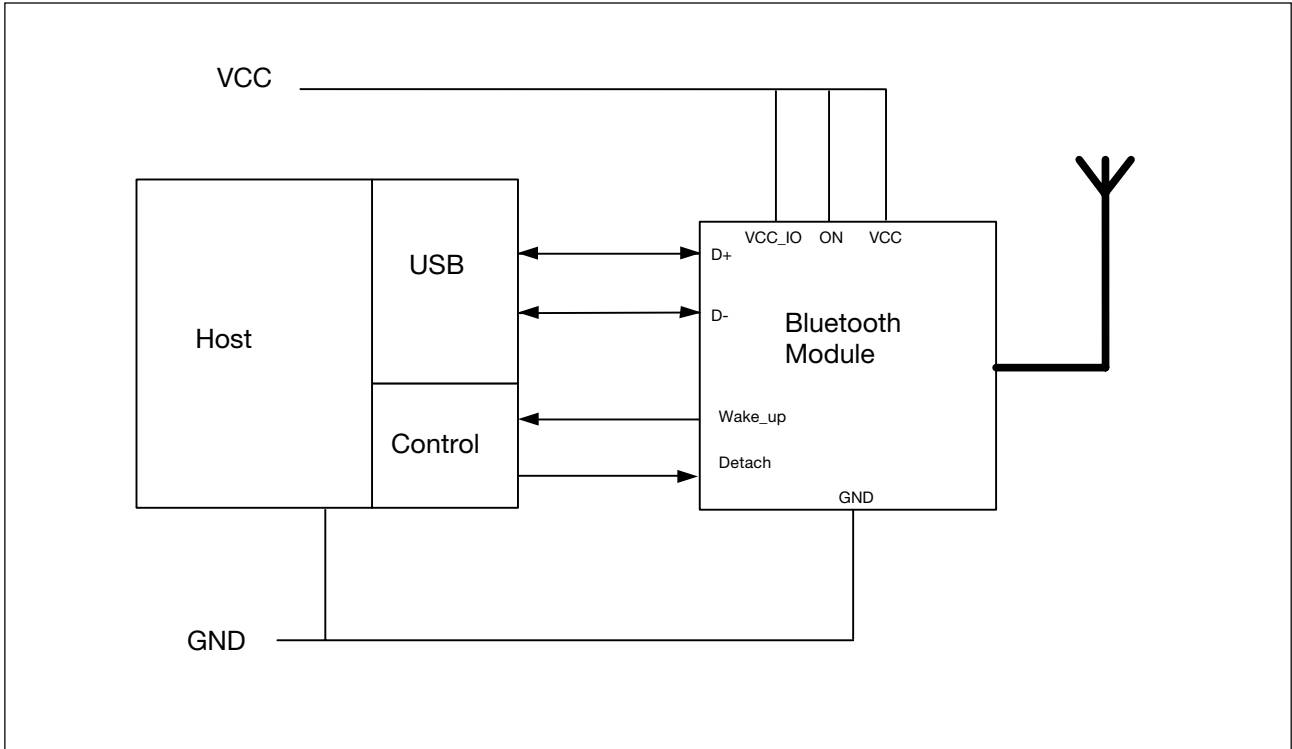

Figure 9. A typical USB configuration.

UART and PCM Application

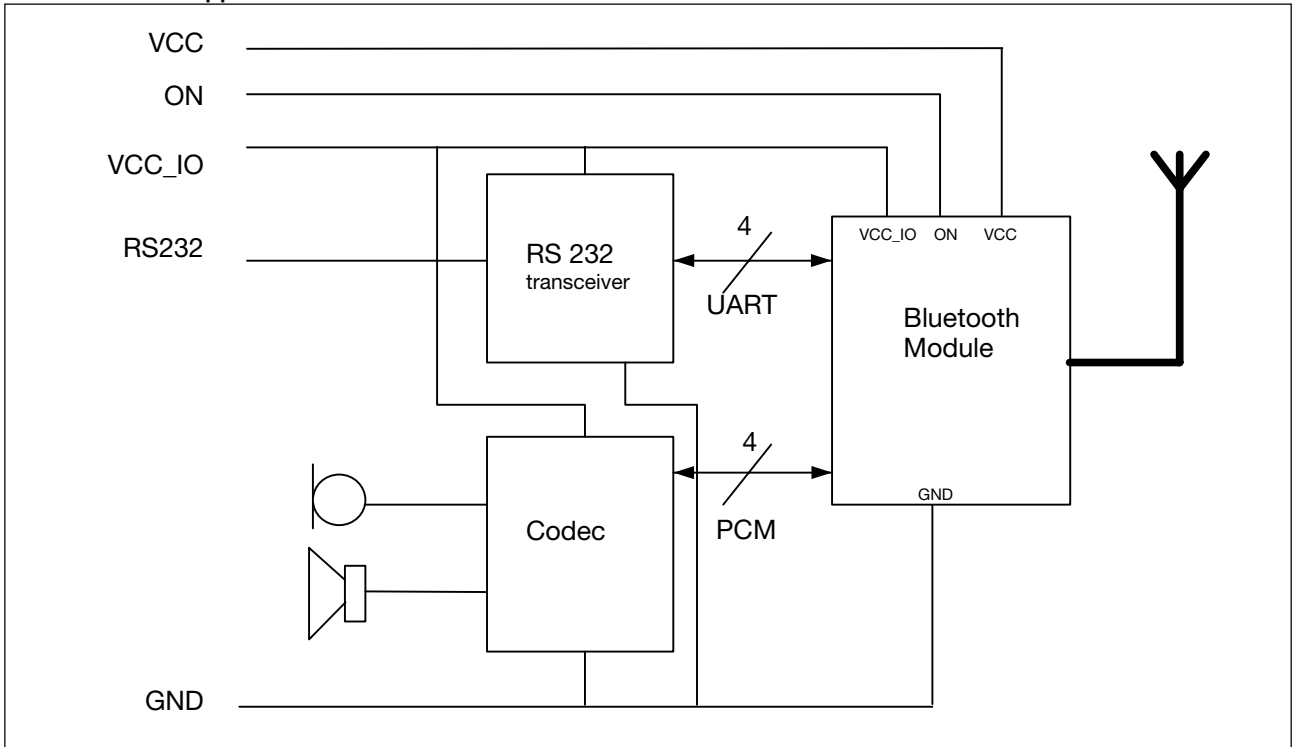

Figure 10. A typical UART or PCM configuration.

Functional Description

The ROK 101 007 is a complete Bluetooth module that has been specified and designed according to the Bluetooth System v1.0B. Its implementation is based on a high-performance integrated radio transceiver (PBA 313 01 /2) working with a baseband controller, a flash memory and surrounding secondary components features low energy consumption for use in battery operated devices.

Block Diagram

ROK 101 007 has five major operational blocks. Figure 11 illustrates the interaction of the various blocks. The functionality of each block is as follows:

1. Radio functionality is achieved by using the Bluetooth Radio, PBA 313 01/ 2. Six operational blocks are shown for the radio section and their operation is as follows:

1a) VCO-tank is a part of the phase locked loop. The modulation is performed directly on the VCO. To ensure high performance the VCO-tank is laser trimmed.

- 1b) Loop filter, filters the tuning voltage of the VCO-tank.
 - 1c) RX-balun handles transformation from unbalanced to balanced transmission.
 - 1d) TX-balun handles biasing of the output amplifier stage and transformation from balanced to unbalanced transmission.
 - 1e) Antenna switch directs the power either from the antenna filter to the receive ports or from the ASIC output ports to the antenna filter.
 - 1f) Antenna filter band-pass filters the radio signal.
2. The baseband controller is an ARM7-Thumb based chip that controls the operation of the radio transceiver via one of the interface methods; USB or UART. Additionally, the baseband controller has a PCM Voice interface and I²C interface.
3. A Flash memory is used together with the baseband controller. Please, refer also to the Firmware section.

4. The power management block regulates and filters the supply voltage. V_{CC} is typically 3.3V and two regulated voltages are produced, 2.8V and 2.2V_{NOM}.
5. An internal clock is mounted on the module. The clock frequency is 13MHz and is generated from a crystal oscillator that guarantees a timing accuracy within ± 20ppm.

Bluetooth Module stack

The Host Controller Interface (HCI) handles the communication by the transport layer through the UART or USB interface with the host. The Baseband and radio provides a secure and reliable radio link for higher layers.

The following sections describe the Bluetooth module stack in more detail. It is implemented in accordance with and complies with the Specification of the Bluetooth System v1.0B.

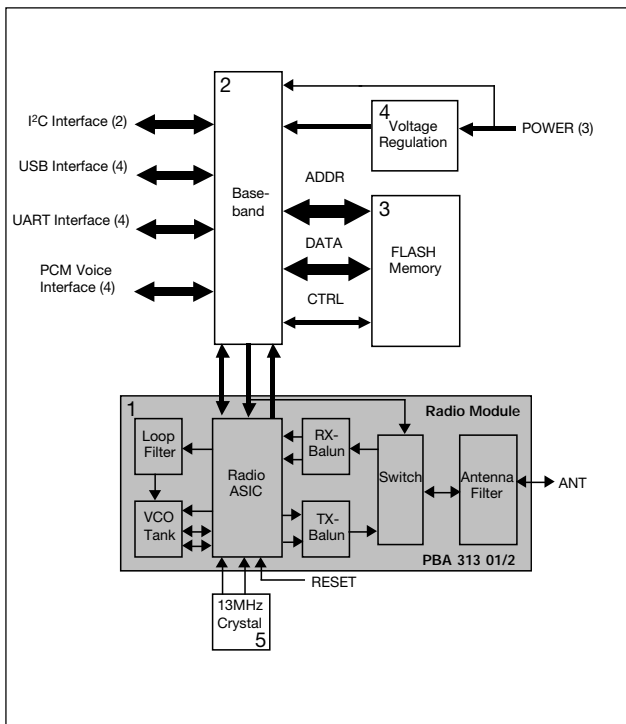

Figure 11. Simplified Block Diagram

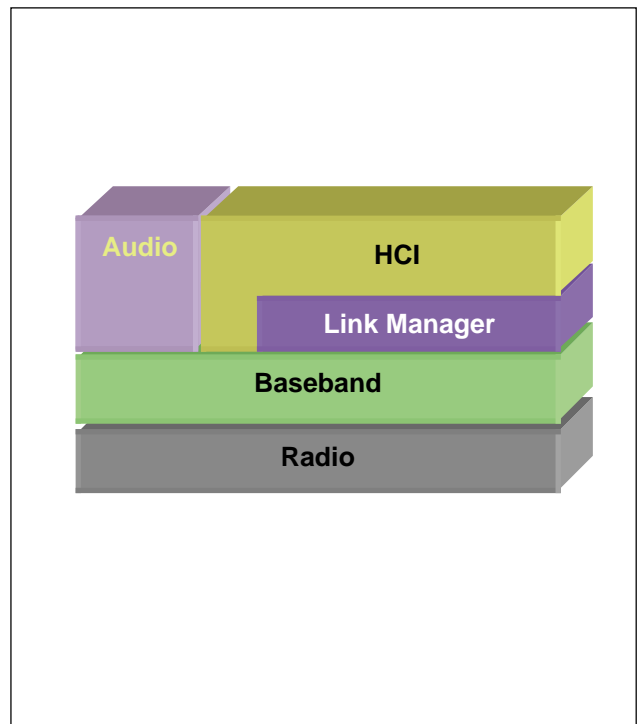

Figure 12. HW/FW parts included in the Ericsson Bluetooth module.

Bluetooth Radio Interface

The Bluetooth module is a class 2 device with 4dBm maximum output power with no power control needed. Nominal range of the module with a typical antenna is up to a range of 10 m (at 0 dBm). It is compliant with FCC and ETSI regulations in the ISM band.

Baseband

Bluetooth uses an ad-hoc net structure with a maximum of eight active units in a single piconet. By default the first unit setting up a connection is the master of the point to point link. The master transmits in the even timeslots and the slave transmits in the odd timeslots.

For full duplex transmission, a Time-Division Duplex (TDD) scheme is used. Packets are sent over the air in timeslots, with a nominal length of 625 μs. A packet can be extended to a maximum of 5 timeslots (DM5 and

DH5 packets) and is then sent by using the same RF channel for the entire packet.

Two types of connections are provided - Asynchronous Connectionless Link (ACL) for data and the Synchronous Connection Oriented Link (SCO) for voice. Three 64 kb/s voice channels can be supported simultaneously. Furthermore, there are also packages used for link control purposes.

A variety of different packet types with error correction schemes and data rates can be used over the air interface. Also asymmetric communication is available for high speed communication in one direction.

The Baseband provides the link-setup and control routines for the layers above. Furthermore, the Baseband also provides Bluetooth

security like encryption, authentication and key management.

Please refer to the Specification of the Bluetooth System v1.0B part B for in-depth information regarding the Baseband.

Firmware (FW)

The module includes firmware for the host controller interface, HCI, and the link manager, LM.

The FW resides in the Flash and is available in object code format.

Link Manager (LM)

The Link Manager in each Bluetooth module can communicate with another Link Manager by using the Link Manager Protocol (LMP) which is a peer to peer protocol.

The LMP messages have the highest priority and are used for link-setup, security, control and power saving modes. The receiving Link Manager

Type	User Payload (bytes)	FEC	CRC	Symmetric Max. rate	Asymmetric Max. rate
ID	na	na	na	na	na
NULL	na	na	na	na	na
POLL	na	na	na	na	na
FHS	18	2/3	yes	na	na

Link control packets

Type	Payload Header (bytes)	User Payload (bytes)	FEC	CRC	Symetric Max. rate (kb/s)	Asymmetric Max rate (kb/s)	
						Forward	Reverse
DM1	1	0-17	2/3	yes	108.8	108.8	108.8
DH1	1	0-27	no	yes	172.8	172.8	172.8
DM3	2	0-121	2/3	yes	258.1	387.2	54.4
DH3	2	0-183	no	yes	390.4	585.6	86.4
DM5	2	0-224	2/3	yes	286.7	477.8	36.3
DH5	2	0-339	no	yes	433.9	723.2	57.6
AUX1	1	0-29	no	no	185.6	185.6	185.6

ACL packets

Type	Payload header (bytes)	User Payload (bytes)	FEC	CRC	Symmetric Max. rate (kb/s)
HV1	na	10	1/3	no	64.0
HV2	na	20	2/3	no	64.0
HV3	na	30	no	no	64.0
DV	1D	10+(0-9) D	2/3 D	Yes D	64.0+57.6 D

SCO packets

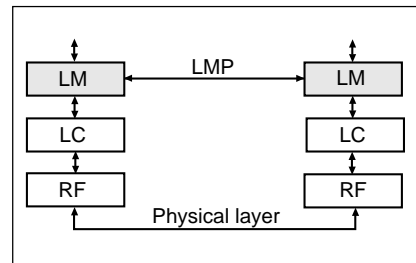

Figure 13. Link manager

filter-out the message and does not need to acknowledge the message to the transmitting LM due to the reliable link provided by the Baseband and radio.

LM to LM communication can take place without actions taken by the host. Discovery of features at other Bluetooth enabled devices nearby can be found and saved for later use by the host.

Please refer to the Specification of the Bluetooth System v1.0B part C for in-depth information regarding the LMP.

Table 1: Link Control Packets Table, ACL Packets Table, SCO packets

Host Control Interface (HCI)

The HCI provides a uniform command I/F to the Baseband and Link Manager and also to HW status registers.

There are three different types of HCI packets:

- HCI command packets – from host to Bluetooth module HCI.
- HCI event packets – from Bluetooth module HCI to host.
- HCI data packets – going both ways.

It is not necessary to make use of all different commands and events for an application. If the application is aimed at a pre-specified profile, the capabilities of such a profile is necessary to adjust to – see Specification of the Bluetooth System v1.0B Profiles.

- With the HCI UART Transport Layer on top of HCI, the module will communicate with a host through the UART I/F. The PCM I/F is also available for communicating voice.
- With the HCI USB Transport Layer on top of the HCI, the module will communicate with a host through the USB. Detach and Wake_up signals are also available for notebook implementations.

Please refer to the Specification of the Bluetooth System v1.0B part H:1-4 for in-depth information regarding the HCI and different transport layers

Module HW Interfaces

UART Interface

The UART implemented on the module is an industry standard 16C450 and supports the following baud rates: 300, 600, 900, 1200, 1800, 2400, 4800, 9600, 19200, 38400, 57600, 115200, 230400 and 460800 bits/s. 128 byte FIFOs are associated with the UART.

Four signals will be provided for the UART interface. TxD & RxD are used for data flow, and RTS & CTS is used for flow control.

Please refer to the Specification of the Bluetooth System v1.0B part H:4 regarding the HCI and UART transport layers.

PCM Voice Interface

The standard PCM interface has a sample rate of 8 kHz (PCM_SYNC). The PCM clock is variable between 200 kHz and 2.0MHz. The PCM data can be linear PCM (13-16bit), μ -Law (8bit) or A-Law (8bit).

The PCM I/F can be either master or slave – providing or receiving the PCM_SYNC. Redirection of PCM_OUT and PCM_IN can be accomplished as well.

Over the air the encoding is programmable to be CVSD, A-Law or μ -Law. Preferably the robust CVSD encoding should be used.

USB Interface

The module is a USB high-speed class device (12Mbps) that has the

full functionality of a USB slave and is compliant to the USB 1.1 specification. Data transfer occurs on the bi-directional ports, D+ & D-.

Additionally, there are two side band signals for a notebook application. Two side band signals Wake_up and Detach are used to control the state from which the notebook resumes. When the host is in a power down mode, Wake_up wakes the host up when the Bluetooth system receives an incoming connection. The host indicates that it is in Suspend mode by using the Detach signal.

I²C Interface

A master I²C I/F is available on the module. The control of the I²C pins are performed by Ericsson specific HCI commands available in the FW implementation – see Appendix C.

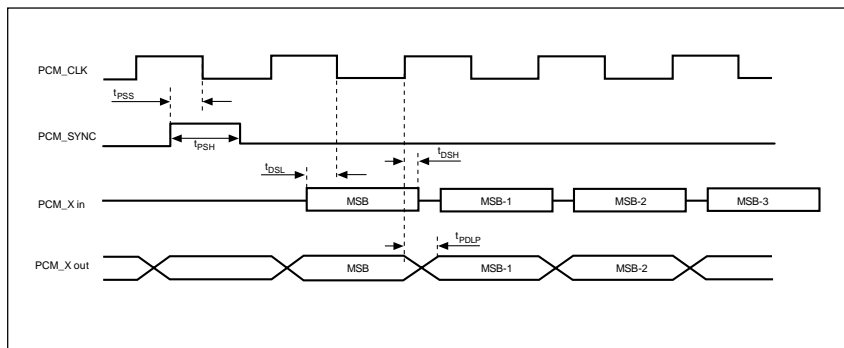

Figure 14. PCM timing

Name	Description	Min	Typ	Max	Unit
f _{pcmClk}	PCM data-transfer clock frequency 1	128		2000	kHz
f _{pcmSync}	PCM sample rate sync. frequency		8		kHz
t _{CCH}	PCM_CLK high period	200			ns
t _{CCL}	PCM_CLK low period	200			ns
t _{PSS}	PCM_SYNC (setup) to PCM_CLK (fall)	100			ns
t _{PSH}	PCM_SYNC pulse length	200			ns
t _{DSL}	PCM_X in (setup) to PCM_CLK (fall)	100			ns
t _{DSH}	PCM_X in (hold) from PCM_CLK (fall)	100			ns
t _{PDLP}	PCM_X out valid from PCM_CLK (rise)	150			ns

Table 2. PCM parameters

Antenna

The ANT pin should be connected to a 50Ω-antenna interface, thereby supporting the best signal strength performance. Ericsson Microelectronics can recommend application specific antennas – see Appendix C.

Power-up Sequence

There is no need for a power up sequence if VCC, ON and VCC_IO are tied together.

A power up sequence, if used, shall be applied accordingly: Connection of the supply rails, GND and then V_{CC}; then the ON signal should be applied in order to initiate the internal regulators; and finally, the V_{CC-IO} supply rail can be activated.

The power-down sequence is similar to the power-up procedure but in the reverse format. Therefore, the disconnection of the signals shall be as follows: V_{CC-IO}, ON, V_{CC} and finally GND.

RESET#

The assignment of the RESET# input is to generate a reset signal to the complete Bluetooth module. During power-up the reset signal is set 'low' automatically so that power supply glitches are avoided. Therefore no reset input should be required after power-up.

When implementing an external RESET#, the signal should be fed from an open drain output.

Power

There are three inputs to the Voltage Management section (V_{CC}, V_{CC-IO}, ON). V_{CC} is the supply voltage that is typically 3.3V.

A separate power supply rail (V_{CC-IO}) is provided for the I/O ports, UART, PCM and USB. To be compliant with the USB 1.1 specification, V_{CC-IO} ≥ 3.11V. V_{CC-IO} can either be connected to V_{CC} or to a dedicated supply rail, which is the same as the logical interface of the host.

Shielding / EMC Requirements

The module has its own RF shielding and is approved according to the standards by FCC and ETSI.

If the approval number is not visible on the outside when the module is utilized in the final product, an exterior label must state that there is a transmitter module inside the product.

Ground

Ground should be distributed with very low impedance as a ground plane. Connect all GND pins to the ground plane.

Assembly Guidelines

Solder Paste

The ROK 101 007 module is made for surface mounting and the SSP connection pads have been formed after printing eutectic Tin/Lead solder paste. The solder paste to use is not critical as long as this is a normal

eutectic solder paste. A preferred solder paste height is 150µm.

Soldering Profile

It must be noted that the module should not be allowed to be hanging upside down in the re-flow operation. This means that the module has to be assembled on the side of the PCB that is soldered last.

The re-flow process should be a regular surface mount soldering profile (full convection strongly preferred); the ramp-up should not be higher than 2°C/s and with a peak temperature of 210-235°C during 20-60 seconds.

Pad Size

It is recommended that the pads on the PCB should have a diameter of 0.7-0.9 mm. The surface finish on the PCB pads should be Nickel/Gold or a flat Tin/Lead surface or OSP (Organic Surface Protection).

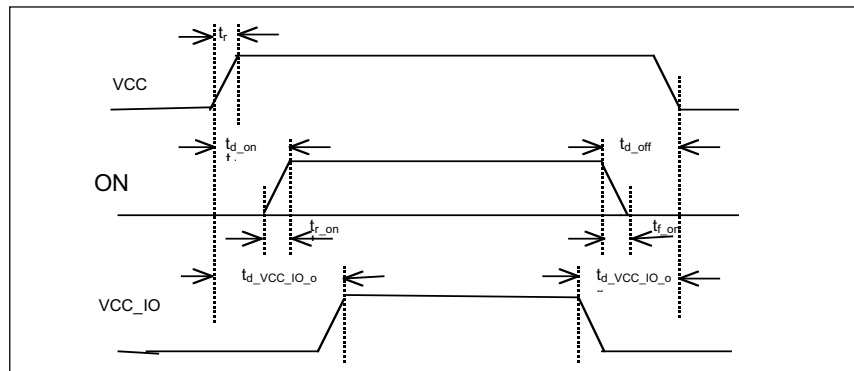

Figure 15. Power up sequence

Parameter	Min	Nom	Max	Unit
t _r			1	ms
t _{r_on}			60	µs
t _{f_on}			60	µs
t _{d_on}	t _r			µs
t _{d_off}				µs
t _{dvcc_io_on}	t _{d_on}			µs
t _{dvcc_io_off}	t _{d_off}			µs

Table 3. Power up parameters

Placement

The placement machine should be able to recognize odd BGA combinations (all ball recognition preferred) and be able to pick the component asymmetrical. The module contains a flat pick-area of 10mm diameter minimum. The weight of the module is typically 2.8gr.

Storage

Keep the component in its dry pack when not yet using the reel. After removal from the dry pack ensure that the modules are soldered onto the PCB within 48 hours.

Marking

Every module is marked with the following information on the:

- a) Component designation: "ROK 101 007".
- b) Ericsson's name and logotype.
- c) Manufacturing code (place, year, week) and batch number.
- d) CE logotype
- e) Type approval RTA no. See manual

Ordering Information

Package	Part No.
30 GP	ROK 101 007/1
30 SSP	ROK 101 007/2

Information given in this data sheet is believed to be accurate and reliable. However no responsibility is assumed for the consequences of its use nor for any infringement of patents or other rights of third parties which may result from its use. No license is granted by implication or otherwise under any patent or patent rights of Ericsson Microelectronics. These products are sold only according to Ericsson Microelectronics' general conditions of sale, unless otherwise confirmed in writing. Specifications subject to change without notice.

Microelectronics

Ericsson Microelectronics AB

SE-164 81 Kista-Stockholm, Sweden
Telephone: +46 8 757 50 00
www.ericsson.com/microe

Packaging

All devices will be delivered in a package protecting them from electrostatic discharges and mechanical shock. The package will be marked with the following information:

- a) Delivery address.
- b) Purchase order-number
- c) Type of goods and component designation.
- d) Ericsson's name and logotype.
- e) Date of manufacture and batch number.
- f) Number of components in the package.

Abbreviations

ASIC	- Application Specific Integrated Circuit
BER	- Bit Error Rate
CMOS	- Complementary Metal Oxide Semiconductor
C/I	- Carrier to Interference Ratio
DCE	- Data Circuit terminating Equipment
GP	- Gold Print
HCI	- Host Controller Interface
ISM	- Industrial Scientific and Medical
PCB	- Printed Circuit Board
PCM	- Pulse Code Modulation
PDA	- Personal Digital Assistant
PtP	- Point to Point
Rx	- Receive
SIG	- Special Interest Group
SSP	- Screen Solder Print
Tx	- Transmit
UART	- Universal Asynchronous Receiver Transmitter
USB	- Universal Serial Bus
VCO	- Voltage Controlled Oscillator

APPENDIX A

Getting Started

The ROK 101 007 Bluetooth module is easy to use when designing a Bluetooth application. However, there is a need for know-how in the Bluetooth System specification v1.0B as well as the Profile specification v1.0B when designing and end-customer product.

- Bluetooth module
- Know-how in Bluetooth specification regarding HCI commands
- Test board with UART/PCM or USB I/F
- Visual C++ for PC SW design
- Preferably HCIdriver, L2CAP, RFCOMM and SDP from Ericsson

The list above show some parts that would make designing convenient.

All information needed, regarding how to drive the HCI over UART is specified in part H4 of the Bluetooth System v1.0B further more part H1 and also Appendix IX with message charts is relevant.

Below follow an example of how to set up an ACL link between to Bluetooth modules by using the UART I/F and also a schematic of how to interface the module and control it by a host, normally a PC or microcontroller.

Principle schematic for UART inter- connect

The inter-connection to the level-shifter when designing a test-board could be according to the schematic below. (Figure A1.)

The Bluetooth module can be connected as a DCE/DTE and a modem/nullmodem cable could therefor be used in-between the test-board and the PC.

Setting up a Bluetooth point-to-point connection

The Host Controller Interface (HCI) in the module is a command I/F. The host presents commands to the HCI and receives events back from the HCI of the module. The module Link Manager provides link set up capability to the HCI.

- Host_B Bluetooth module is set in paging scan mode – listening for a Bluetooth device asking for a new connection
- Host_A Bluetooth module is set in paging mode asking for a connection to Host_B

This is accomplished by first setting up the connection between the Host and the module and thereafter creating the connection between the modules using HCI commands.

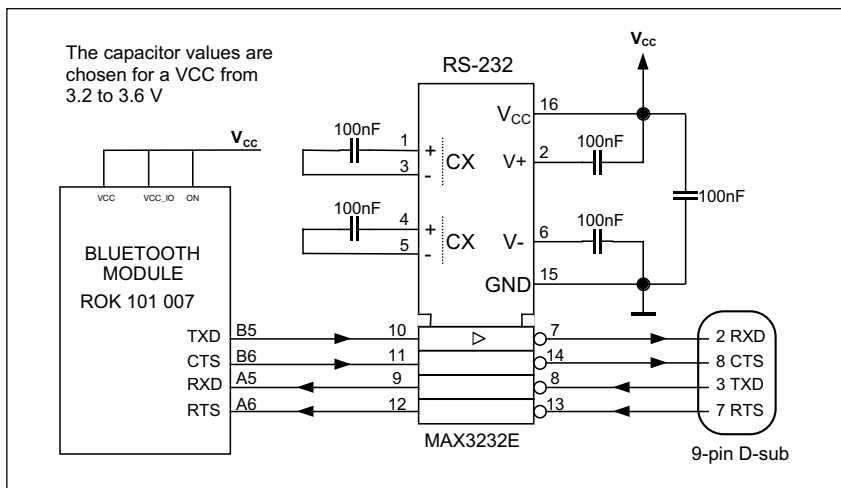

Figure A1. Bluetooth module connected as a DCE through level shifter

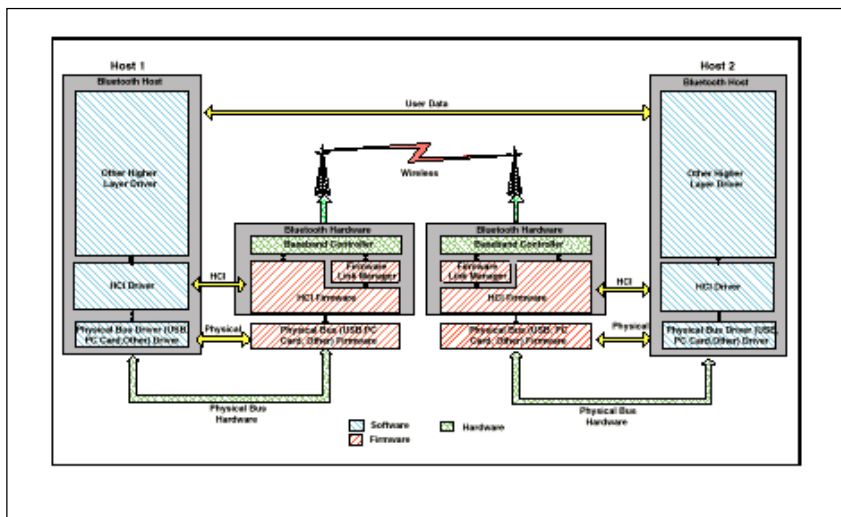

Figure A2. Bluetooth host to host communication

Host set-up via UART:

There are 4 different types of HCI-packets accepted on the UART I/F.

HCI packet type	HCI packet indicator
HCI command packet	0x01
HCI ACL data packet	0x02
HCI SCO data packet	0x03
HCI event packet	0x04

Table A1. HCI packets

The HCI packet indicator shall be sent immediately before the HCI packet. When the entire HCI packet has been received a new indicator should be expected.

The default speed setting is 57.6 kb/s and can be changed by sending a specified bit stream to the I/F - see Appendix C on how to change the speed setting of the UART.

When the speed set-up for the UART is made for both Host_ A & B, the Command Packets can be sent and Event Packets received by the hosts. See HCI over UART in part H:4 of the Bluetooth System v1.0B for detailed information regarding parameters and protocol.

Soft Reset

First HCI command packet to send should be the RESET packet.

A Command_Complete_Event with a status parameter should be returned to the host.

Buffer information

Buffer information should be exchanged between the module and respective host by using HCI commands.

- Read_Buffer_Size: Providing the host with information on buffer size for ACL and SCO data packets for the module returned with a Command_Complete_Event packet. The host shall use this information for controlling the transmission
- Host_Buffer_Size: Providing the module with information on buffer size for ACL and SCO packets to the host.

It is the host that manages the data buffers of the Host Controller on the module.

Timers

It could be necessary to set important timers used by the module for time out handling. The timers are all set by writing to registers using HCI commands.

The default values can be checked in Specification of the Bluetooth System v1.0B part H:1 or by using Read_xxx_xxx commands.

Bluetooth Address

The hosts, using the HCI command Read_BD_ADDR will find the Bluetooth address of the module by the Command_Complete_Event with the BD_ADDR as a parameter.

By Remote_Name_Request, the BD_ADDR of the remote module can also be found.

Inquiry

The HCI command Inquiry with the parameters LAP, Inquiry_Length, and Num_Responses can also be used for collecting BD_ADDR of remote Bluetooth units.

Creating a Point-to-point connection

Page Scan mode

Command	OCF	Command parameters	Return parameters
HCI_Write_Scan_Enable	0x0005	Scan_Enable	Status

Table A2. HCI Write Scan Enable OCF code

To set a Bluetooth module in the mode for being able to connect to (Host_B), page scan mode, there are some settings that should be performed.

The Write_Scan_Enable command with correct parameter (Scan_Enable=0x001A) will set the module in Page scan mode if the Command_Complete_Event is successful.

Furthermore the setting of authentication and encryption should be disabled (default) by using the:

- Write_Authentication_Enable
- Write_Encryption_Mode

The basic settings for getting into scan mode could be according to the below suggested script list.

- Read Buffer Size
- Set Event Filter
- Write Scan Enable: (Scan Enable: 0x03)
- Write Voice Setting: (Voice Channel Setting: 0x0060)
- Write Authentication Enable: (Authentication Enable: 0x00)

- Set Event Filter: (Connection Setup Filter: Connections from All Devices, Auto Accept: 0x02)

Write Connection Accept		Return parameters
Command	OCF	Command parameters
HCI_Create_Connection	0x0005	BD_ADDR Packet_Type Packet_Scan_Repetition_Mode Packet_Scan_Mode Clock_Offset

Table A3. HCI Create Connection OCF code

Timeout: (Connection Accept Timeout: 0x2000)

- Write Page Timeout: (Page Timeout: 0x3000)

Page mode

The Create_Connection command is used to set-up a link to another Bluetooth device.

Create_Connection:
BD_ADDR: 0xYYYYYYYYYYYY,
Packet Type: 0x0007,
Page Scan Repetition Mode: 0x01,
Page Scan Mode: 0x00, Clock Offset: 0x0000

This command will cause the Link Manager to try to create a connection to the Bluetooth module with the appropriate BD_ADDR. The local Bluetooth module (Host_A) starts the paging process to set up a link to the page-scanning remote device (Host_B).

By LMP the negotiation between the two Bluetooth modules Link Managers (LM) the link set-up can be completed.

ACL link up and running

Host_A is the master of the point-to-point piconet and Host_B is slave. The unit starting the paging process is by definition the master. The link set-up is completed when the event Connection_Complete_Event is returned to both Host_A and Host_B with the connection handle as one of the parameters and the status parameter 0x00 (success). When Bluetooth link is up and running the HCI data packets can be sent from host to host.

The host must take care of generating the packages going from Host to Host Controller in the module over the UART I/F, in the same way the Host must arrange the packages received from the Host Controller.

Both sides need information on what kind of data is received, to be able to interpret the bit flow correctly.

For extensive information on setting up a Bluetooth link please refer to Bluetooth System v1.0B Appendix IX Message Sequence Charts

Adding an SCO link

When creating a voice connection using the PCM I/F, an ACL link must be up and running between the two devices, an SCO link can thereafter be added.

The control of the PCM I/F (FS, PCM_IN/OUT and PCM_CLK) is handled by Ericsson specific HCI command – see Appendix C.

Driving SW

HCI- API

The Bluetooth module includes all HCI command capabilities according to Bluetooth System v1.0B. Furthermore, there is some Ericsson specific commands available for accessing HW registers and HW control – see Appendix C. SW for driving the module should be developed for the HCI interface.

There is source code SW available with Ericsson Bluetooth Developers Kit (EBDK), see Appendix B, which can be used for driving the module. This SW comes with the EBDK and has an HCI-API for application development on the HCI I/F.

Higher layer-API

Software (HCIdriver, L2CAP, RFCOMM and SDP) are available in a generic, source code format, i.e. to be adapted to various operating systems.

- HCIdriver – implements the HCI command driver used by the host
- L2CAP – handles protocol multiplexing, segmentation and re-assembly of packets
- RFCOMM – provides a serial port emulation over the L2CAP protocol
- SDP – Service Discovery Protocol provides information on the services available on a Bluetooth device

Additional SW for the application shall be developed for the actual application on top of the RFCOMM API. If the application is according to a SIG predefined profile, it should be implemented accordingly. New applications can be the driver of the specification of new profiles decided by the SIG – see Specification of the Bluetooth System v1.0B Profiles.

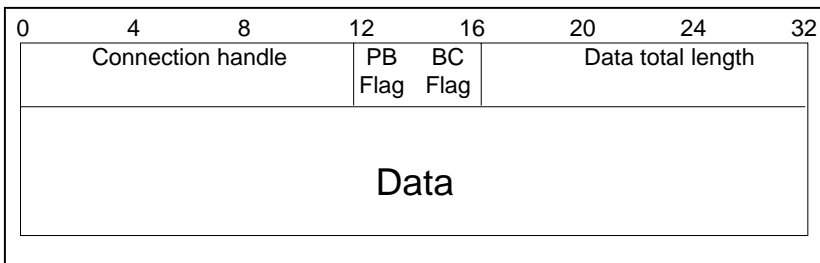

Table A4. ACL data packet

APPENDIX B

Development tools

Ericsson Bluetooth Development Kit (EBDK)

The easiest way of getting started is to use the Ericsson Bluetooth Developers Kit. It provides all parts necessary for developing applications for the Bluetooth module.

Available are:

- PC plug&play
- Demos using radio/baseband
- Macro capability
- C++ v5.0 Source code for use in applications
- HCI driver, L2CAP, SDP and RFCOMM for applications using UART communication
- Pins for electrical measurements
- Antennas

Development can easily take place on the EBDK platform and thereafter the implementation of the full Bluetooth capability can be setup by developed SW/HW and the Bluetooth module.

Software (HCI driver, L2CAP, RFCOMM and SDP) will be available in source code for PC.

- HCI driver – implements the HCI command driver used by the host
- L2CAP – handles protocol multiplexing, segmentation and re-assembly of packets
- RFCOMM – provides a serial port emulation over the L2CAP protocol
- SDP – Service Discovery Protocol provides information on the services available on a Bluetooth device

Technical support is available from the EBDK distributor. Please contact Ericsson Microelectronics for ordering and information regarding the

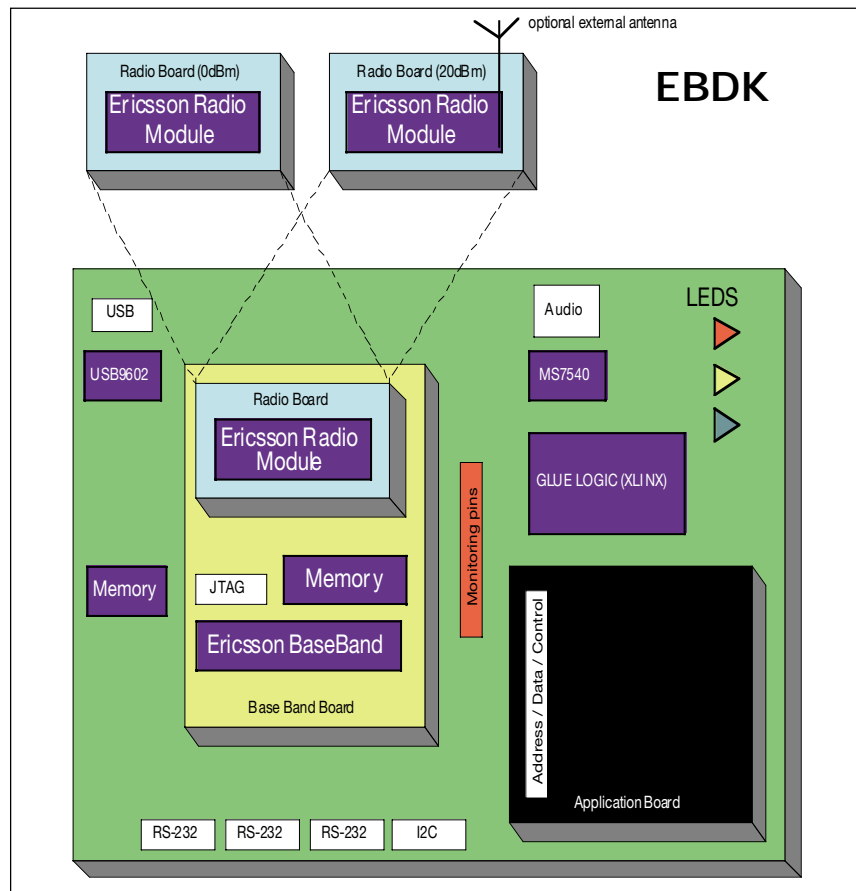

Figure B1. Ericsson Bluetooth Development Kit (EBDK)

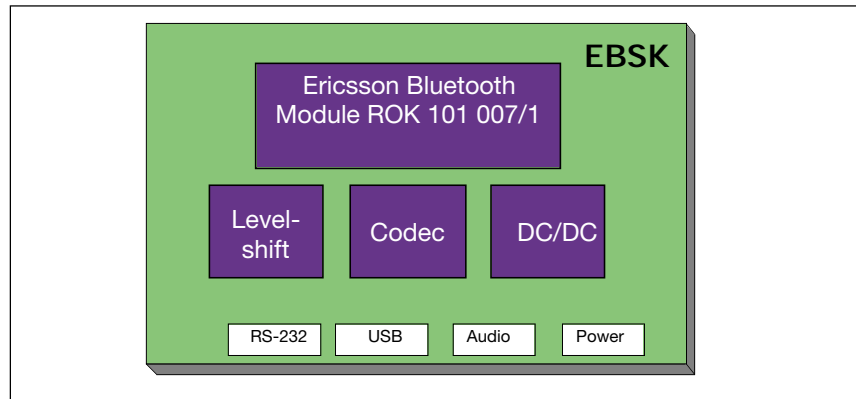

Figure B2. Ericsson Bluetooth Starter Kit (EBSK)

EBDK and regarding extra daughter board with ROK 101 007 as add-on to the EBDK.

Ericsson Bluetooth Starter Kit (EBSK)

A very small convenient kit, which preferably is used in point-to-multipoint configuration designs,

based on the Bluetooth module ROK 101 007.

Please contact Ericsson Microelectronics for ordering and information regarding the Ericsson Bluetooth Starter Kit.

APPENDIX C

Bluetooth Information

This part will be updated and new information will be added continuously.

Radio

Fast Frequency hopping (1600channel hop/s) with 79(23) channels available (2.402 to 2.480 GHz) and a symbol rate of 1Ms/s over the air exploits the maximum channel bandwidth in the unlicensed ISM band.

To sustain a high transfer rate in busy radio environment, the frequency hopping together with advanced coding techniques maximizes the throughput.

During Page and Inquiry the hopping frequency is risen to 3200 hops/s to enhance the time needed for connection set-up.

Modulation technique is a binary Gaussian Frequency Shift Keying GFSK, with a BT product of 0.5. The channel bandwidth is 1 MHz and the frequency deviation from the carrier frequency of the RF channel is between +/-140 to +/-175 kHz for representing a '1'/'0'.

Country	Frequency range	RF channels	
Europe & USA	2400-2483.5 MHz	f = 2402 + k MHz	k = 0...78
Japan	2471-2497 MHz	f = 2473 + k MHz	k = 0...22
Spain	2445-2475 MHz	f = 2449 + k MHz	k = 0...22
France	2446.5-2483.5 MHz	f = 2454 + k MHz	k = 0...22

Table C1. Frequency ranges used.

A rapid process is ongoing to harmonise Spanish, French and Japanese frequency ranges with the rest of the world.

Data and parameter formats

There are exceptions in the Bluetooth system for data and parameter formats – general rules below.

- All values are in Binary and Hexadecimal little Endian formats
- Negative values must use 2's complement format

- Array parameter notation is parameterA[i], parameterB[i],...
- All parameter values are sent/received in little Endian format. The least significant byte is sent first – unless noted otherwise.

HCI Opcodes

The Opcodes have been changed during the ongoing standardisation work. Below is the description on how to send opcodes to the module.

Below is the general HCI command

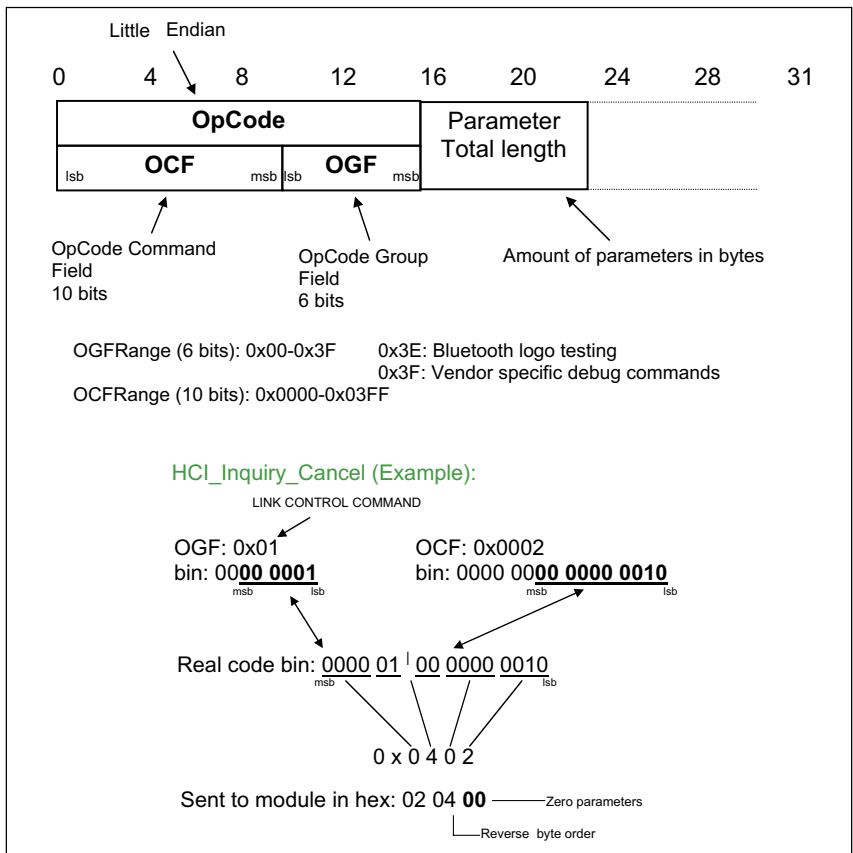

Figure C1. Byte order sent to module

packet format depicted as well as a byte order description.

UART speed setting

The baud rate is changed with an Ericsson specific HCI command. HCI_Ericsson_Set_Uart_Baud_Rate

The command has one parameter, baud rate - one byte long according to the table below . The op-code for the command is 0xfc07 - the last figure is due to a possible change.

Sending the command should be performed accordingly: 07 fc 01 yz , where yz is the chosen baud rate from the table.

The op-code is sent in reverse byte order. 01 is the parameter length, in this case one byte. Remember to add the HCI packet indicator.

UART speed	Parameter to send
460.8 kbps	00000
230.4 kbps	00001
115.2 kbps	00010
57.6 kbps	00011
28.8 kbps	00100
14.4 kbps	00101
7200 bps	00110
3600 bps	00111
1800 bps	01000
900 bps	01001
153.6 kbps	10000
76.8 kbps	10001
38.4 kbps	10010
19.2 kbps	10011
9600 bps	10100
4800 bps	10101
2400 bps	10110
1200 bps	10111
600 bps	11000
300 bps	11001

Table C2. UART speed setting parameter

Observe - When changing the baud rate for the module the host also has to change the baud rate.

Observe - Removing power to the module the baud rate will be reset to 57.6 kbps.

Observe -Two zeros are not printed in the beginning of the binary parameters below. The length of the parameter is 1 byte.

Ericsson specific HCI commands

By using the Ericsson specific HCI command there are a number of features available for the application design.

Contact Ericsson Microelectronics for a command reference list.

Antennas

Antenna design is not specified and standardised in the Bluetooth System v1.0B.

Many different types of antennas can and will be used. Application specific antennas suitable for production are expected to be a new market for antenna designs.

Ericsson Microelectronics have antennas for the EBDK and other

development kits. Contact Ericsson Microelectronics for information on antennas.

Contacting Ericsson Microelectronics

For further information regarding Bluetooth technology, components and development tools, please contact Ericsson Microelectronics:

Telephone:
 Scandinavia: +46 8 757 47 00
 Europe: +44 1793 488 300
 North America: +1 877 374 26 42
 Rest of World: +46 8 757 47 00

www.ericsson.se/microe