

Rhein Tech Laboratories
360 Herndon Parkway
Suite 1400
Herndon, VA 20170
<http://www.rheintech.com>

Client: Zebra Technologies
FCC: Part 15.247
Industry Canada: RSS-210
FCC ID: I28-QL420352
M/N: QL420

APPENDIX I: MANUAL

Please see the following pages.



QL 420tm

Mobile Printer User's Guide

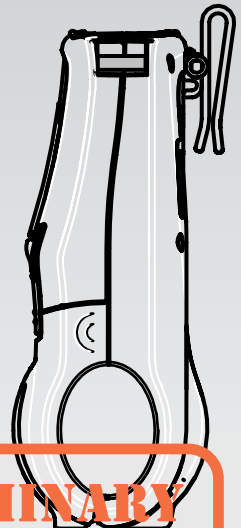
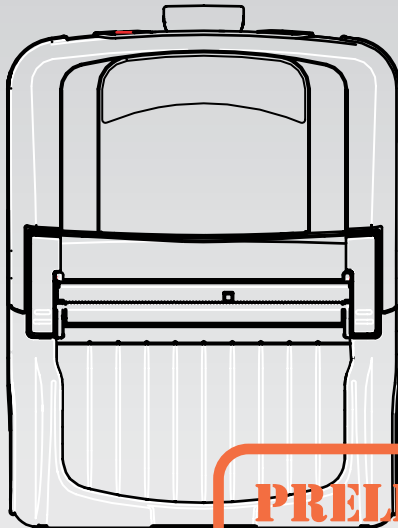
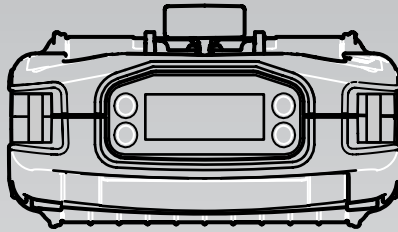

PRELIMINARY

Proprietary Statement

This manual contains proprietary information of Zebra Technologies Corporation. It is intended solely for the information and use of parties operating and maintaining the equipment described herein. Such proprietary information may not be used, reproduced, or disclosed to any other parties for any other purpose without the expressed written permission of Zebra Technologies Corporation.

Product Improvements

Since continuous product improvement is a policy of Zebra Technologies Corporation, all specifications and signs are subject to change without notice.

FCC Compliance Statement

NOTE: This equipment has been tested and found to comply with the limits for a Class B digital device, pursuant to Part 15 of FCC Rules. These limits are designed to provide reasonable protection against harmful interference when the equipment is operated in a commercial environment. This equipment generates, uses, and can radiate radio frequency energy and, if not installed and used in accordance with the instruction manual, may cause harmful interference to radio communications. Operation of this equipment in a residential area is likely to cause harmful interference in which case the user will be required to correct the interference at his own expense.

WARNING: Exposure to Radio Frequency radiation. To conform to FCC RF exposure requirements this device shall be used in accordance with the operating conditions and instructions listed in this manual. Note that there are several radio options available with this printer. Additional regulatory information is contained in later sections devoted to each radio individually.

NOTE: This unit was tested with shielded cables on the peripheral devices. Shielded cables must be used with the unit to insure compliance.

Changes or modifications to this unit not expressly approved by Zebra Technologies Corporation could void the user's authority to operate this equipment.

Canadian Compliance Statement

This Class B digital apparatus complies with Canadian ICES-003.

Cet appareil numérique de la classe B est conforme à la norme NMB-003 du Canada.

"IC:" before the equipment certification number signifies that the Industry Canada technical specifications were met. It does not guarantee that the certified product will operate to the user's satisfaction.

Agency Approvals and Regulatory Information

- Built to UL and CSA standards
- Canadian STD RSS-210
- EN55022:1998 Class B European Electromagnetic Radiation Standard
- EN55022:1998 European Immunity Standard
- EN60950: 2000 Safety Standard
- NOM/NYCE (Mexico)
- C-Tick (Australia)

Liability Disclaimer

Inasmuch as every effort has been made to supply accurate information in this manual, Zebra Technologies Corporation is not liable for any erroneous information or omissions. Zebra Technologies Corporation reserves the right to correct any such errors and disclaims liability resulting therefrom.

No Liability for Consequential Damage

In no event shall Zebra Technologies Corporation or anyone else involved in the creation, production, or delivery of the accompanying product (including hardware and software) be liable for any damages whatsoever (including, without limitation, damages for loss of business profits, business interruption, loss of business information, or other pecuniary loss) arising out of the use of or the results of use of or inability to use such product, even if Zebra Technologies Corporation has been advised of the possibility of such damages. Because some states do not allow the exclusion of liability for consequential or incidental damages, the above limitation may not apply to you.

Copyrights

The copyrights in this manual and the system described therein are owned by Zebra Technologies Corporation. All rights are reserved. Unauthorized reproduction of this manual or the software in any of the system modules may result in imprisonment of up to one year and fines of up to \$10,000 (17 U.S.C.506). Copyright violators may be subject to civil liability.

All products and brand names are trademarks of their respective companies. All rights reserved. ©2003 Zebra Technologies Corporation



QL 420tm

Mobile Printer
User's Guide

Contents

Introduction	7
Unpacking and Inspection	7
Reporting Damage	7
Getting Ready to Print	9
Battery	9
<i>Installing the Battery</i>	9
<i>Charging the Battery</i>	9
Loading the Media	12
<i>Installing the Media</i>	12
Operator Controls	16
<i>Standard Keypad</i>	16
<i>LCD Control Panel</i>	18
Verify the Printer Is Working	21
<i>Printing a Configuration Label</i>	21
Connecting the Printer	21
<i>Cable Communications</i>	22
<i>IR Communications</i>	23
<i>Wireless Communications with Bluetooth™</i>	24
<i>Wireless Local Area Network Module (CF Radio)</i>	26
<i>Wireless Local Area Network Module (PCMCIA Radio)</i> ..	27
Setting Up the Software	29
Using the Accessories	30
<i>Belt Clip</i>	30
<i>Adjustable Shoulder Strap</i>	30
Preventive Maintenance	31
Extending Battery Life	31
Cleaning	32
Troubleshooting	34
Standard Control Panel	34
Optional LCD Control Panel	34
Troubleshooting Topics	35
Troubleshooting Tests	36
<i>Printing a Configuration Label</i>	36
<i>Sample Configuration Label</i>	37
<i>Communications Diagnostics</i>	39
<i>Calling the Help Desk</i>	39
Specifications	40
Printing Specifications	40
Memory/Communications Specifications	40

Label Specifications	41
Font/Bar Code Specifications	41
Physical/Environmental/Electrical Specifications	42
Communications Port	43
Accessories	44
Appendix A	47
<i>Interface Cables</i>	
Appendix B	51
<i>Media Supplies</i>	
Appendix C	51
<i>Maintenance Supplies</i>	
Appendix D	52
<i>Product Support</i>	
Index	53
Patent Information	55

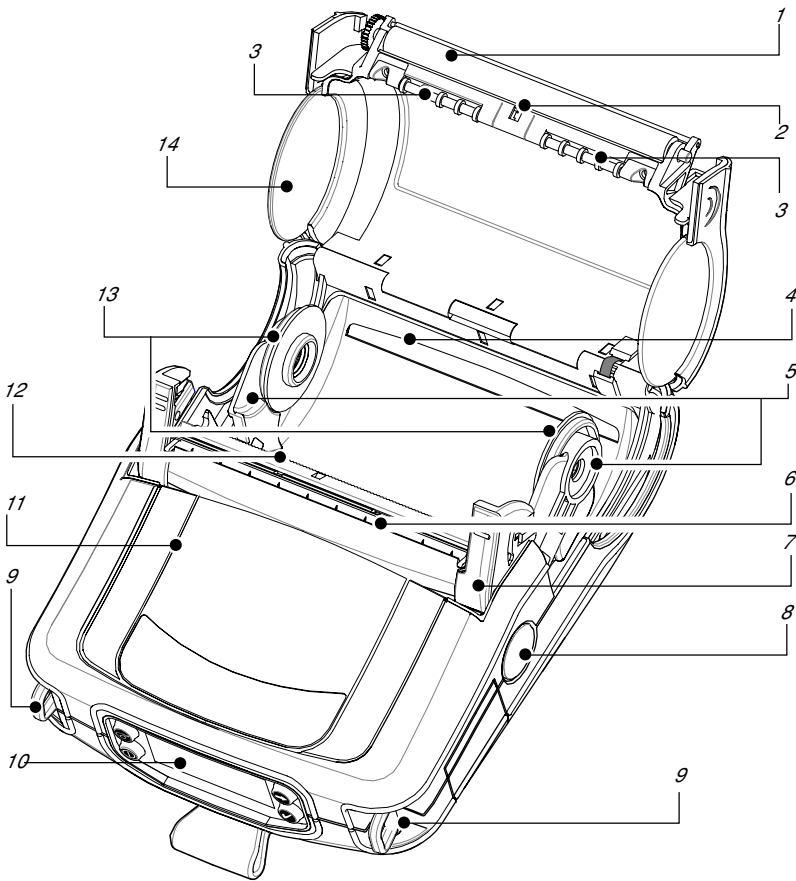

- 1. Platen Roller
- 2. Bar Sensor
- 3. Media Rollers
- 4. Rear Media Slot
- 5. Media Support
- 6. "EZ-Peel" Peeler
- 7. Latch
- 8. Latch Release Button
- 9. "D" Rings
- 10. Control Panel
- 11. QuickLink™ Module
- 12. Print Head
- 13. Media Support Disks
- 14. Media Cover

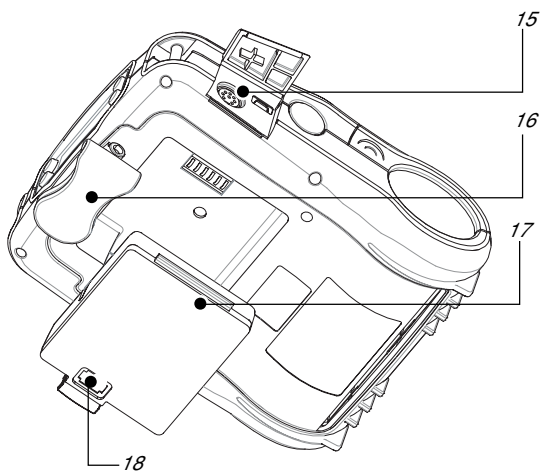

FIGURE 1: QL 420 OVERVIEW

Introduction

Thank you for choosing our Zebra QL 420 Mobile Printer. This rugged printer is sure to become a productive and efficient addition to your workplace thanks to its innovative design. Because it's made by Zebra Technologies Corporation, you're assured of world-class support for all of your bar code printers, software, and supplies.

- This user's guide gives you all the information you'll need to operate the QL 420 printer.
- The QL 420 uses the CPL programming language. To create and print labels using the CPL language, refer to the Mobile Printer Programming Guide (available on our website at: <http://www.zebra.com/SS/manuals.htm>) and our Label Vista™ label creation program.
- The QL 420 has an optional interpreter for the ZPL II® Programming Language which interprets commands up to X.8 firmware. The printer must be equipped with the optional memory upgrade and appropriate application in order to use this function. A ZPL II Program Guide (part #46530L) can be used as reference for the ZPL II label design programming language. If either manual was not ordered with the printer, simply call your re-seller or Zebra Technologies Corporation or visit the Zebra web site.

Unpacking and Inspection

Inspect the printer for possible shipping damage:

- Check all exterior surfaces for damage.
- Open the media cover (refer to "Loading the Media" in the Getting Ready to Print section) and inspect the media compartment for damage.

In case shipping is required, save the carton and all packing material.

Reporting Damage

If you discover shipping damage:

- Immediately notify and file a damage report with the shipping company. Zebra Technologies Corporation is not responsible for any damage incurred during shipment of the printer and will not cover the repair of this damage under its warranty policy.
- Keep the carton and all packing material for inspection.
- Notify your authorized Zebra re-seller.

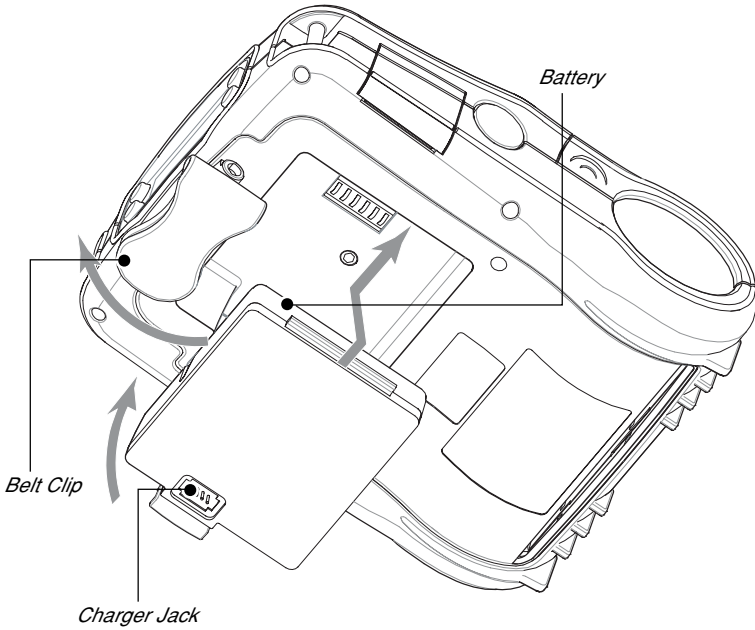

FIGURE 2: INSTALLING THE BATTERY

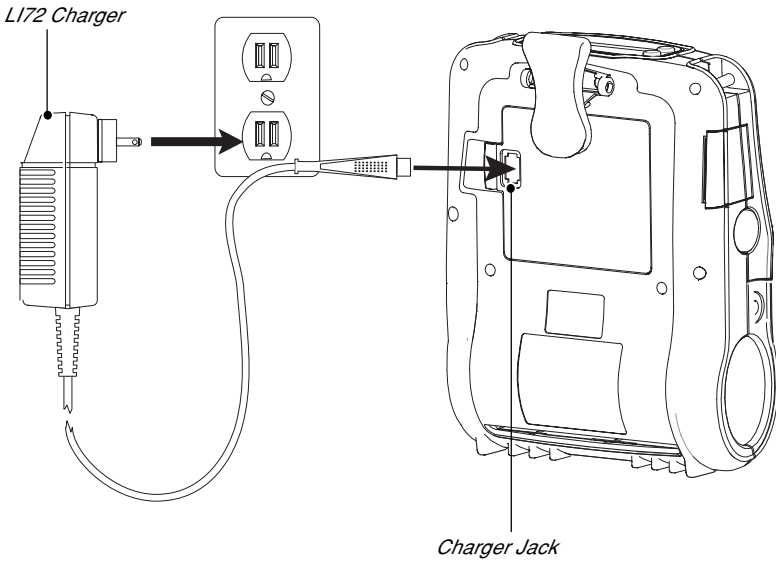

FIGURE 3: SINGLE CHARGER

Getting Ready to Print

Battery

Installing the Battery

 **NOTE: Batteries are shipped uncharged. Remove protective shrink-wrap and labels from new battery packs prior to use.**

1. Rotate the Belt Clip to allow access to the Battery compartment.
2. Insert the battery into the printer as shown in Figure 2,
3. Rock the Battery into the printer as shown until it locks in place.

When the battery is first installed, the Control Panel indicators may briefly turn on and then go off which indicates the battery is not fully charged (see “Charging the Battery” below and “Operator Controls”).

Charging the Battery

If you are using the LI 72 single battery charger:

Refer to Figure 3. Your battery charger may look slightly different from the ones illustrated.

1. Install the battery in the printer and plug the Charger into the appropriate A.C. wall receptacle. Then insert the charge cable into the battery charger jack.
2. The charger LED will indicate the status of the charger as follows:
 - A steady light indicates the battery is undergoing a fast charge.
 - A slow blinking light indicates the charger is in trickle mode. The battery is ready for use.
 - A rapidly blinking light indicates a problem with the battery. The battery may have an internal short, or its charge monitoring circuitry may be malfunctioning. The battery should not be used any further.
 - Battery Packs may be charged either when installed in the printer or when removed.

 **Do not attempt to charge batteries with the LI 72 while printing. Attempting to print while charging can result in improperly charged batteries.**

continued on next page

If you are using the Quad Charger:

The UCLI72-4 Quad Charger is designed to charge up to four QL 420 battery packs simultaneously. Batteries must be removed from the printer to be charged in the Quad Charger.

1. Ensure that the charger has been installed properly per the Quad Charger instruction manual. Ensure that the power indicator on the front panel is on.
2. Remove any protective shrink-wrap and labels from all battery packs prior to use. Plug a battery pack into any one of the four charging bays as shown in Figure 4, noting the orientation of the battery pack. Slide the battery pack into the charging bay until it stops. Then rock the battery pack back until it snaps into place. The amber indicator directly under the battery being charged will turn on if the battery is properly inserted.

The indicators under the battery will allow you to monitor the charging process per the table below:

Amber	Green	Battery Status
On	Off	Charging
On	Flashing	80% charged (O.K. to use)
Off	On	Completely Charged
Flashing	Off	Fault

⚠ Note: A fault condition is caused by a problem with the battery. The charger may indicate a fault because the battery is too hot or cold to charge reliably. Try to charge the battery again when it returns to the room's ambient temperature. If the Amber indicator starts flashing on the second attempt, the battery should be discarded.

Quad Charger Cycle Times for QL 420 Batteries:

- Battery 80% Charged 2.5 Hrs.
- Battery Fully Charged 5 hrs.

These times are for completely discharged batteries. Battery packs which are only partially discharged will take less time to reach their charged state. Batteries which have reached 80% of their charge capacity may be used, however, it is recommended that you allow the batteries to reach a full charge to maintain maximum battery life.

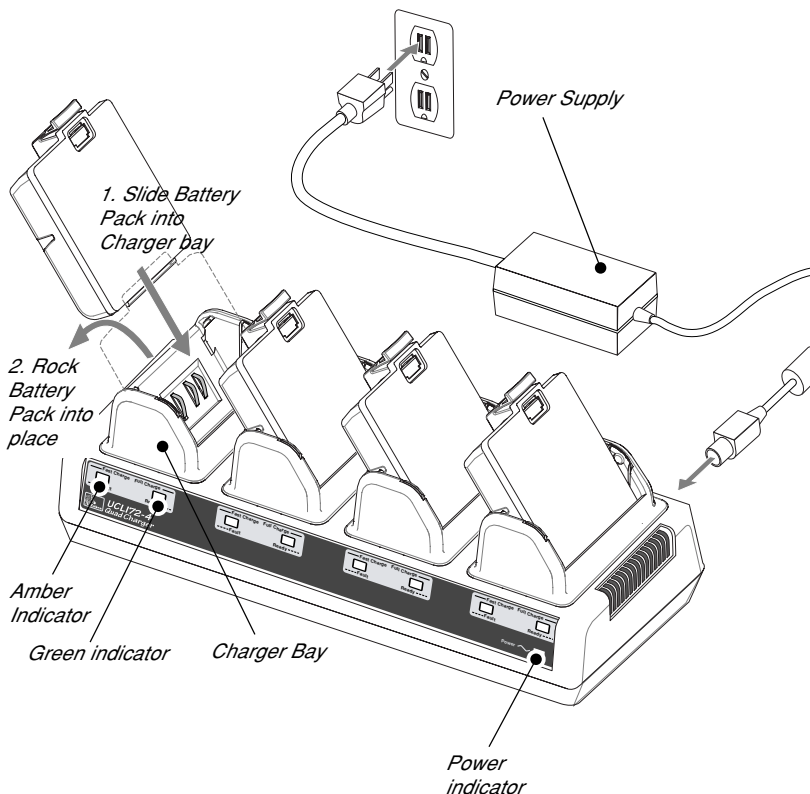

FIGURE 4: QUAD CHARGER

The UCL172-4 Quad Charger has a safety feature which stops charging a battery after six hours regardless of its charge state.

Battery Safety

⚠ Avoid accidental short circuiting of any battery. Allowing battery terminals to contact conductive material will create a short circuit which could cause burns and other injuries or could start a fire.

Use of any charger not approved specifically by Zebra for use with its batteries could cause damage to the battery pack or the printer and will void the warranty.

Charger Safety

Use care in locating the Quad Charger. Do not place it in locations where liquids or metallic objects may be dropped into the charging bays. Do not block the ventilating slots on the top and bottom covers. Insure that the Charger is plugged into a power source which won't accidentally be turned off if you will be charging batteries overnight.

Loading the Media

You can operate this printer in one of two different modes: Tear-Off or Peel-Off. Tear-Off mode allows you to tear off each label (or a strip of labels) after it is printed. In Peel-Off mode, the backing material is peeled away from the label as it is printed. After you remove this label, the next one is printed.

Installing the Media

1. **Open the printer:** Refer to Figure 5.

- Press the latch release button on the side of the printer as shown at “1” below. The latch assembly will flip open automatically
- Pull up on the latch assembly as shown at “2” to unlatch the Media Cover.
- Rotate the media Cover back as shown at “3”, exposing the media compartment and the adjustable media supports.

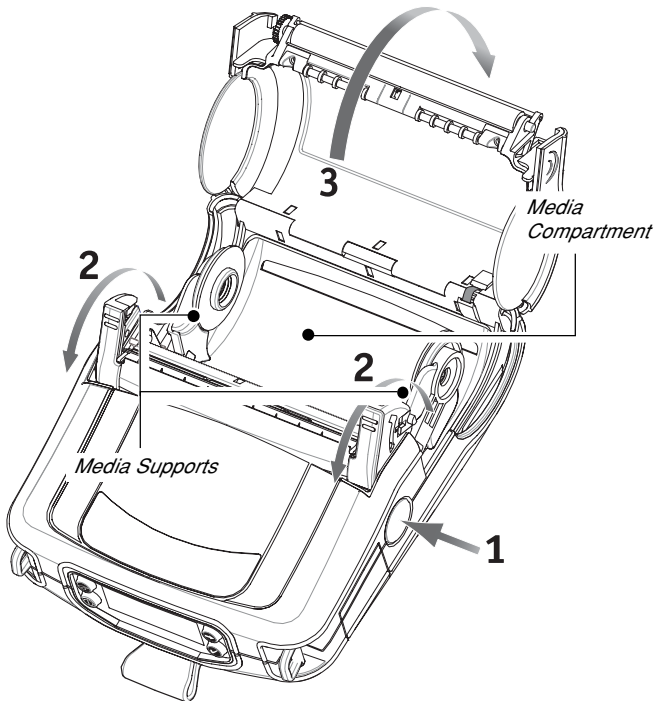

FIGURE 5: OPENING THE QL 420

2. Load the media:

Loading media from an internal supply. Refer to Figure 6.

- Pull the media supports apart, insert the roll of media between them, and let the media supports close. Insure that the media pulls off the core in the direction shown in Figure 6. The supports will adjust themselves to the width of the media, and the media should be able to spin freely on the supports.

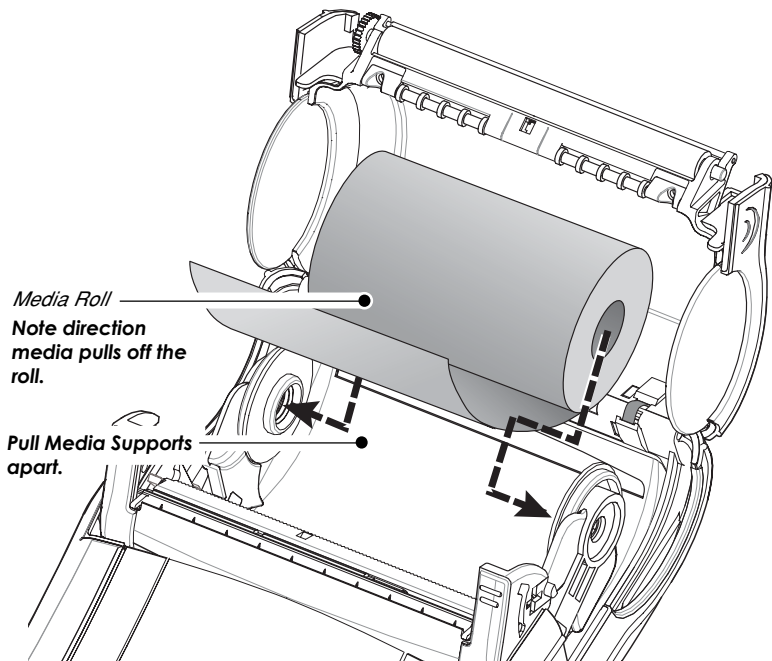

FIGURE 6: INSTALLING MEDIA IN THE QL 420

continued on next page

2A. Load the media (continued):

Loading media from an external supply. Refer to Figure 7.

The QL 420 has a loading slot in the rear of the media compartment which allows you to use standard 4" (101.6 mm) wide fan-fold media from an external supply. The external supply must be designed such that it does not exert excessive drag as media is fed through the printer, which could result in distorted printing.

- Pull the media supports apart, insert a Media Spacer (Zebra part number BA16625-1) between them, and let the media supports close. Insert the media from the external supply through the rear feed slot, between the media guides and up through the media compartment as shown. Make sure the side of the media you will be printing on faces the print head.

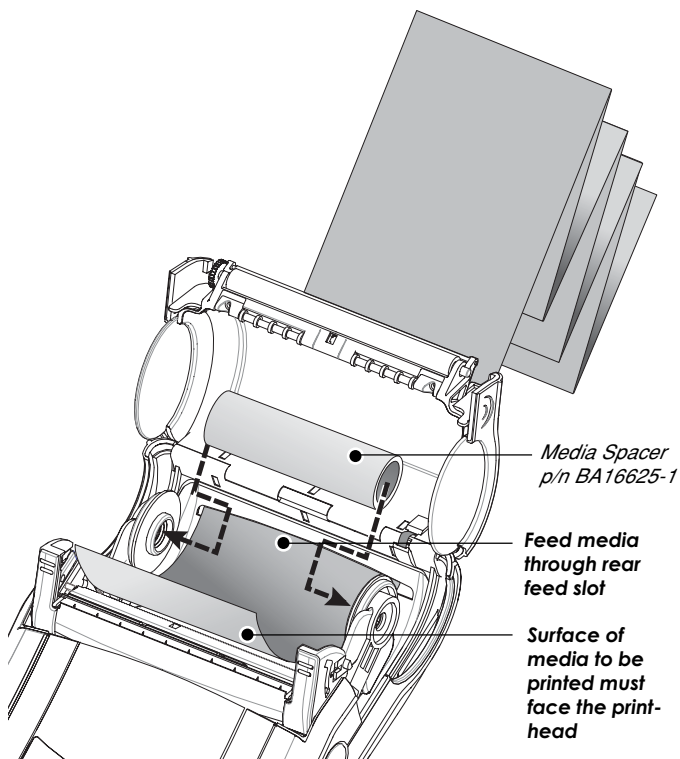

FIGURE 7: INSTALLING MEDIA FROM AN EXTERNAL SUPPLY

3. Close the Media Cover Refer to Figure 8.

- If you plan to use the printer in the tear-off mode, close the media cover as shown at “2”, then rotate the latch assembly as shown until it locks into place, as shown at “4”.
- If you plan to use the printer in the peel-off mode, peel a few labels off of the media and pull it out of the printer as shown at “1”. Close the media cover as shown at “2”. Rotate the “EZ-Peel” peeler bar until it locks into place on the latch, as shown at “3”, then rotate the Latch as shown until it locks into place, as shown at “4”.
- Turn on the printer or press the Feed button if the printer is already on.

The printer will advance the media to the next label, if printing labels. If you are printing on journal media, the printer will advance a short strip of media and will then be ready for printing.

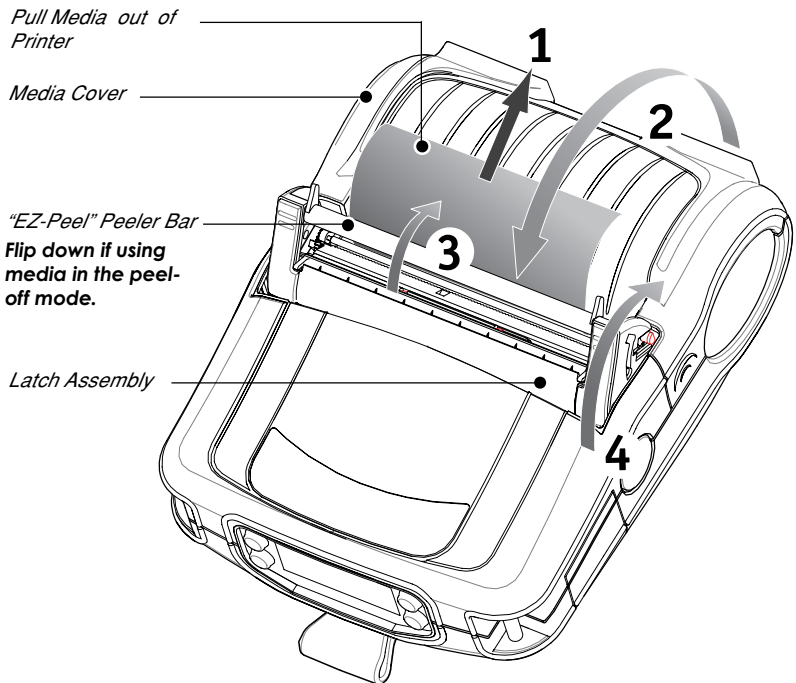

FIGURE 8: CLOSING THE QL 420

Operator Controls

The QL 420 will come with one of two possible control panels. The standard control panel is detailed below and in Figure 9. The optional control panel (Figure 10) features an LCD which allows easy display and selection of many printer functions detailed on following pages.

Standard Keypad

The standard keypad has three control buttons and two multi-purpose indicators.

- The Power button turns the QL 420 on and off.
- The Feed button advances a length of media which is determined by the type of media being used. Label media will be advanced to the next gap or bar sense marker. Journal (plain) media will be advanced a length determined by the printer's software.
- The Function button is controlled by a printer's specific application to support such functions as:
 - Print a battery level report.
 - Print the Local Area Network (LAN) status
 - Print a Short Range Radio Frequency (SRRF) status
 - Print a media supply report

The green LED on the left side of the control panel indicates the status of several printer features:

- A slowly blinking sequence indicates the printer's battery needs charging.
- Printers with a wireless QuickLink module installed: a quickly blinking sequence indicates the printer has not established a link to either a Local Area Network or a compatible wireless equipped terminal.
- Printers with a wireless QuickLink module installed: A steadily lit indicator shows that the printer has established a wireless link, either to the LAN or to a compatible terminal.
 - A steadily lit green indicator on a non-wireless printer is a power-on indicator.

The yellow LED on the right side of the control panel has two indication conditions.

- A rapidly blinking yellow LED and a chime indicate that no application has been loaded into the printer.

- Printers with a wireless QuickLink module installed: a rapidly blinking LED indicates normal data transmission.
- A steadily lit yellow LED indicates an error condition. This can be caused by one of the following:
 1. The media cover is not completely closed and latched.
 2. The printer is out of media.

Green LED

Steady Light indicates power on and/or established RF link.

Fast Blink indicates no RF link (on RF equipped units only)

Slow Blink means low battery

Power Button

Press to turn unit on. Press again to turn unit off

Yellow LED

Steady Light indicates error condition: out of media or media cover not closed.

Fast Blink indicates RF activity (on RF equipped units only)

Fast blink with beeper indicates no application loaded

Feed Button

Press to advance the media one blank label or a software determined length of journal media.

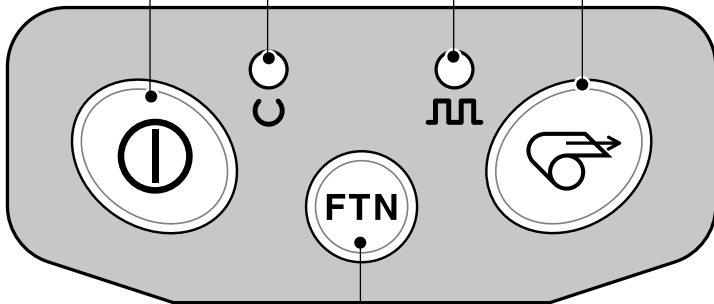

Function Button

Specific functions are under printer application control.

FIGURE 9: STANDARD CONTROL PANEL

continued

LCD Control Panel

The optional LCD control panel has buttons for the power on/off and media feed functions just as in the standard control panel. In addition, it has two keys which allow easy navigation and selection of menu options affecting many printer functions.

The “Scroll” button allows scrolling through the various options and settings. The “Select” button allows selection of the option or function displayed on the screen.

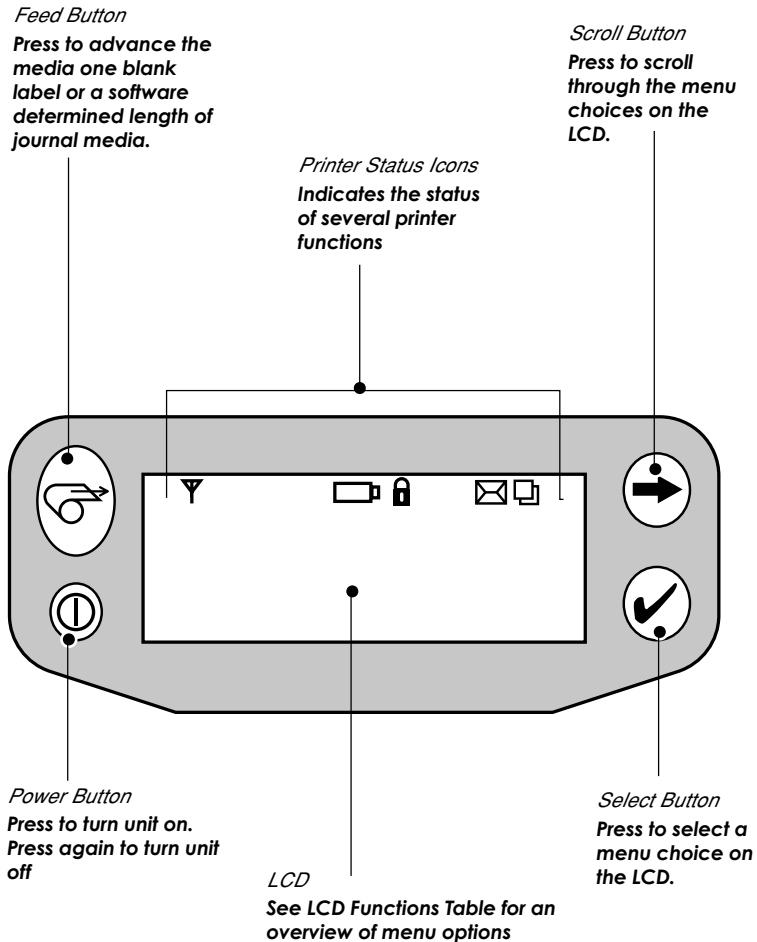





FIGURE 10: OPTIONAL LCD CONTROL PANEL

The top of the screen has a row of status icons which indicate the state of various printer functions:

 Indicates that the printer is associated with a wireless Local Area Network (LAN). This icon is functional only with QL 420N network printers.

 A flashing icon indicates low battery status. You should suspend any printing operations and recharge or replace the Battery Pack as soon as is convenient.

 A flashing icon indicates that the media cover is open or not properly latched.

 A flashing icon indicates that a file is being downloaded to the printer.

 A flashing icon indicates that the printer does not detect any media. This could indicate an out of media condition, or improperly loaded media.

In addition to the status icons, the LCD control panel can display many of the printer's settings and functions as text. Applications can be written to allow the user to view and /or modify these settings using the scroll and select keys on the display. Refer to the "LCD Functions Table" on the following page for the full set of printer features that can be made available with the LCD panel.

The LCD has a backlighting option which allows viewing of the screen in a dark environment, or provides better contrast in a very bright environment. Use of the display backlight will decrease the time the printer will run between charges. Refer to the section "Extending Battery Life" for more information.

LCD Functions		
Function	Default setting	Scroll & Select Options
Sensor Type	Gap	<ul style="list-style-type: none"> • Bar • Gap
Baud Rate	19200	<ul style="list-style-type: none"> • 9600 • 19200 • 32400
Data Bits	8	<ul style="list-style-type: none"> • 7 • 8
WLAN ID*	Factory Set Value	N/A
Label Top	000	<ul style="list-style-type: none"> • Increase (+120 dots max.) • Decrease (-120 dots max.)
Left Position	000	<ul style="list-style-type: none"> • Increase (+120 dots max.) • Decrease (-120 dots max.)
LCD Contrast	0	<ul style="list-style-type: none"> • Increase • Decrease
No-activity Timeout*	60 sec.	<ul style="list-style-type: none"> • 60 sec. • 5 min. • 10 min. • 30 min • Custom
Tear-off Position	00	<ul style="list-style-type: none"> • Increase (+120 dots max.) • Decrease (-120 dots max.)
Media Type	Label	<ul style="list-style-type: none"> • Label • Journal
Media Width Sensing†	Off	<ul style="list-style-type: none"> • On • Off • Display Width
LCD Backlight	Off	<ul style="list-style-type: none"> • On • Off • Momentary On w/ time delay
Factory Reset (Resets all to factory set values)	No	<ul style="list-style-type: none"> • No • Yes

* Some parameters, such as the WLAN ID number and non-standard no-activity time out values can be set using a PC running Zebra's Label Vista label creation program and a data cable link to the printer.

† Media width sensing is an option. Display for this option may not be visible, or selection options may change, depending on the printer's application.

Verify the Printer Is Working

Before you connect the printer to your computer or portable data terminal, make sure that the printer is in proper working order. You can do this by printing a configuration label using the “two key reset” method. If you can’t get this label to print, refer to “Troubleshooting”.

Printing a Configuration Label

1. Turn the printer off. Load the media compartment with journal media (media with no black bars printed on the back)
2. Press and hold the Feed Button.
3. Press and release the Power button and keep the Feed button pressed. When printing starts, release the Feed button.

The unit will print a line of interlocking “x” characters to insure all elements of the print head are working, print out the version of software loaded in the printer and then print two reports.

The first report indicates model, ROM version, serial number, baud rate, etc. The second report prints out more detailed information on the printer’s configuration and parameter settings. If no second report appears, there is no application loaded. (See the Troubleshooting Section for a sample print-out and a further discussion on how to use the configuration label as a diagnostic tool.)

Connecting the Printer

The printer must establish communications with a host terminal which sends the data to be printed. Communications occur in four basic ways:

- By a cable between the printer and its host terminal
- Linking to a host terminal via Infrared (usually by means of the industry standard IrDA protocol)*
- By means of a Bluetooth™ short range radio frequency link.
- By means of a wireless LAN (Local Area Network) per 802.11b specifications†.

* The IR option has not been released at time of printing

† The 802.11b WLAN option has not been released at time of printing

Cable Communications

⚠ CAUTION. *The power should be turned off before connecting or disconnecting the communications cable.*

All QL 420 printers can communicate by cable; the specific cable supplied with your printer will vary with the host terminal. The 8-pin circular connector on your communications cable plugs into the serial communications port on the side of the QL 420 printer, which is protected by a weather resistant flap. The connector is keyed to assure correct alignment; do not try to force the cable if it does not plug in. The other end of the cable must be plugged into the host terminal as shown in Figure 11, or to a serial port on a computer (Figure 12.) Communications between the terminal and the printer are controlled by the applications

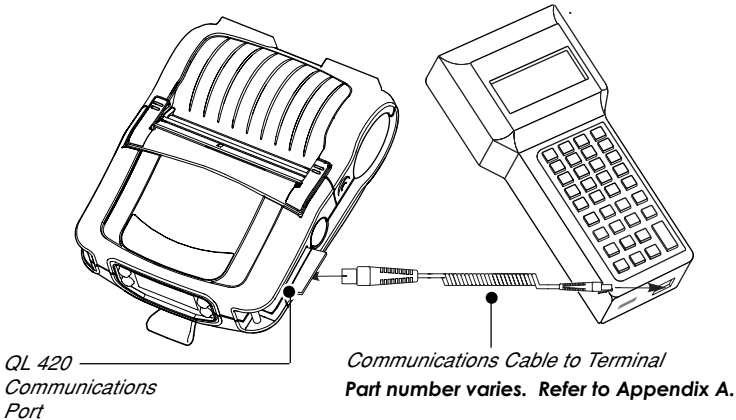

FIGURE 11: CABLE COMMUNICATIONS

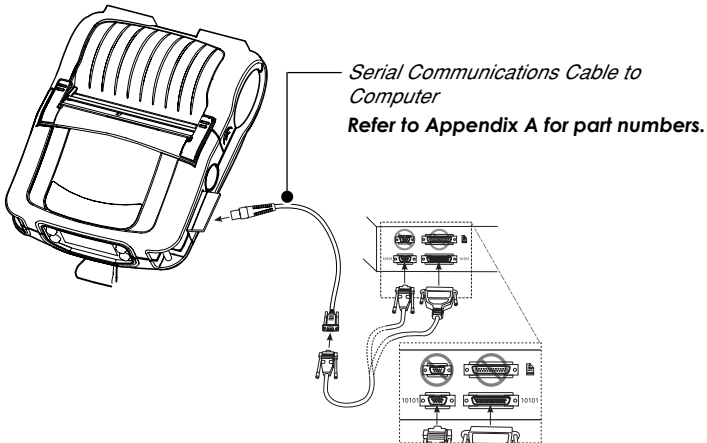

FIGURE 12: COMMUNICATIONS WITH A P.C.

running on the terminal and the printer.

IR Communications

(This option not released at time of printing)

Printers equipped for infrared (IR) communications are identified by a small "IR" logo on the unit's label. IR allows wireless communications between the printer and the host terminal. IR units can also communicate with a cable as detailed above, however, IR functions are disabled when the cable is plugged in. QL 420 units with the IR option can be configured to conform to the standard IrDA communications protocol.

Linking a Printer to an IrDA Host

IrDA compliant terminals will automatically initiate communications to the printer. First insure that there is a direct line of sight between the printer and the terminal that will be sending data. The IR window on the front of the QL 420 must face the corresponding window on the terminal to properly send and receive signals. An IrDA compliant terminal will seek out any linkable devices and establish communications between them, even turning the printer on if necessary.

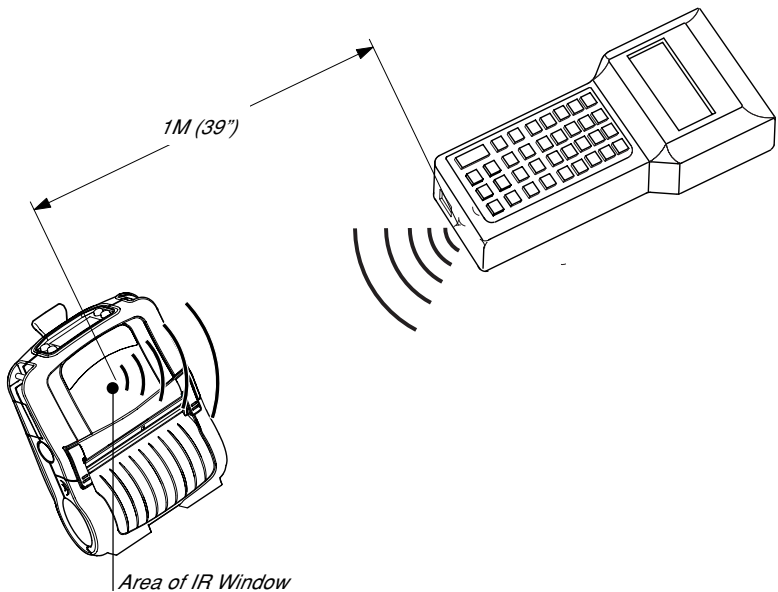

FIGURE 13: IR COMMUNICATIONS

Wireless Communications with Bluetooth™

The following section only applies when the Bluetooth Module (FCC ID: I28MD-BTC2-E) is installed in the QL 420 printer (note that only one of the radio options can be installed in the printer at one time).

“Bluetooth” is a worldwide standard for the exchange of data between two devices via radio frequencies. Bluetooth radios are relatively low powered to help prevent interference with other devices running at similar radio frequencies. This limits the range of a Bluetooth device to about 10 meters (about 32 feet).

Both the printer and the device it communicates with must follow the Bluetooth standard.



Exposure to Radio Frequency Radiation

The radiated output power of this internal wireless radio is far below the FCC radio frequency exposure limits. Nevertheless, this Bluetooth radio must be used in such a manner that the antenna is 2.5 cm or further from the human body.

The radio and antenna are mounted internally in this printer in such a way that, when the printer is used in a standard configuration (belt clip, soft case, shoulder strap), the 2.5 cm distance from the users body will be met. Do not use the printer in an unauthorized manner.

The internal wireless radio operates within guidelines found in radio frequency safety standards and recommendations. The level of energy emitted is far less than the electromagnetic energy emitted by wireless devices such as mobile phones.

European Regulatory Information for this Radio

AUS	B	DK	FIN
F	D	GR	IRE
I	LUX	NL	P
E	S	UK	

Note: -Member states in the EU with restrictive use for this device are crossed out!

This device is also authorized for use in all EFTA member states (**CH, ICE, LI, NOR**)

Important Notice:

This device is a portable RF printer intended for commercial and industrial use in all EU and EFTA member states except in France where restrictive use applies.

Please refer to the regulatory information pages in the user manual for further details.

Europe EU Declaration of Conformity

This device complies with the essential requirements of the R&TTE Directive 1999/5/EC. The following test methods have been applied in order to prove presumption of compliance with the R&TTE Directive 1999/5/EC:

- EN 300 328-2 V1.2.1 (2001-12)- Technical requirements for spread spectrum radio equipment
- EN 300 328-2 V1.1.1 (2000-09)- EMC requirements for spread-spectrum radio equipment

In France there are restrictions in the use of this device. A restricted frequency band exists in France. When operating this device on French territory you may only use channels 10 and 11 (2457 and 2463 MHz). It is not allowed to operate this device at any other frequency supported by the device. For more information see <http://www.anfr.fr/>

Bluetooth™ Networking Overview

In order to exchange data, two Bluetooth enabled devices must establish a connection. Bluetooth software is always running in the background, ready to respond to connection requests. One device (known as the *master* or the *client*) must request a connection with another. The second device (the *slave* or the *server*) then accepts or rejects the connection. A Bluetooth enabled QL 420 will normally act as a slave, but in theory any Bluetooth device can be either a master or a slave. This miniature network is sometimes referred to as a “piconet” and can consist of several Bluetooth enabled devices.

Each Bluetooth QL 420 has a unique Bluetooth Device Address (BDA) loaded into its Quick Link module when manufactured. For the most part, communications using the Bluetooth protocol are initiated and processed without any operator intervention, much like the IrDA system described previously.

Wireless Local Area Network (WLAN) Module Using CF Radio

The following section only applies when the CF (Compact Flash) WLAN module (With FCC ID: I28MD-QL4137) is installed in the QL 420 printer (note that only one of the radio options can be installed in the printer at one time). The FCC ID number label is on the front of the module and can be read with the module installed.

⚠ WARNING: Use of the QL 420 with the radio module marked “with FCC ID: I28MD-QL4137” meets the FCC requirements for radio frequency (RF) radiation exposure in the standard body worn configuration with no minimum separation. In this configuration, which applies whether the belt clip or shoulder strap is used, the face of the printer from which paper is transported is facing away from the user’s body. The standard configuration must always be used when the printer is body worn.

The printer with this radio option has been SAR tested. The maximum SAR value measured was 1.1W/kg averaged over 1 gram.

European Regulatory Information for this Radio

AUS	B	DK	FIN
F	D	GR	IRE
I	LUX	NL	P
E	S	UK	

Note: -Member states in the EU with restrictive use for this device are crossed out!

This device is also authorized for use in all EFTA member states (**CH, ICE, LI, NOR**)

Important Notice:

This device is a portable RF printer intended for commercial and industrial use in all EU and EFTA member states except in France where restrictive use applies.

Please refer to the regulatory information pages in the user manual for further details.

Europe EU Declaration of Conformity

This device complies with the essential requirements of the R&TTE Directive 1999/5/EC. The following test methods have been applied in order to prove presumption of compliance with the R&TTE Directive 1999/5/EC:

- EN 300 328-2 V1.2.1 (2001-12)- Technical requirements for spread-spectrum radio equipment
- EN 301 489-17 V1.1.1 (2000-09)- EMC requirements for spread-spec-trum radio equipment

In France there are restrictions in the use of this device. A restricted frequency band exists in France. When operating this device on French territory you may only use channels 10 and 11 (2457 and 2463 MHz). It is not allowed to operate this device at any other frequency supported by the device. For more information see <http://www.anfr.fr/>

Wireless Local Area Network (WLAN) Module Using PCMCIA Radio

The following section only applies when the PCMCIA WLAN module (FCC ID: I28-QL420352) is installed in the QL 420 printer (note that only one of the radio options can be installed in the printer at one time). The FCC ID number label is on the front of the module and can be read with the module installed.

⚠ WARNING: Use of the QL 420 with the radio module marked with FCC ID: I28-QL420352 meets the FCC requirements for radio frequency (RF) radiation exposure in the standard body worn configuration with no minimum separation. In this configuration, which applies whether the belt clip or shoulder strap is used, the face of the printer from which paper is transported is facing away from the user's body. The standard configuration must always be used when the printer is body worn. This configuration maintains the required 1 cm separation distance.



The printer with this radio option has been SAR tested. The maximum SAR value measured was 1.04. W/kg averaged over 1 gram.

European Regulatory Information for this Radio

AUS	B	DK	FIN
F	D	GR	IRE
I	LUX	NL	P
E	S	UK	

Note: -Member states in the EU with restrictive use for this device are crossed out!

This device is also authorized for use in all EFTA member states (**CH, ICE, LI, NOR**)

 0336 	<p>Important Notice: This device is a portable RF printer intended for commercial and industrial use in all EU and EFTA member states except in France where restrictive use applies. Please refer to the regulatory information pages in the user manual for further details.</p>
---	---

Europe EU Declaration of Conformity

This device complies with the essential requirements of the R&TTE Directive 1999/5/EC. The following test methods have been applied in order to prove presumption of compliance with the R&TTE Directive 1999/5/EC:

- EN 300 328-2 V1.2.1 (2001-12)- Technical requirements for spread-spectrum radio equipment
- EN 301 489-17 V1.1.1 (2000-09)- EMC requirements for spread-spectrum radio equipment

In France there are restrictions in the use of this device. A restricted frequency band exists in France. When operating this device on French territory you may only use channels 10 and 11 (2457 and 2463 MHz). It is

continued on next page

not allowed to operate this device at any other frequency supported by the device. For more information see <http://www.anfr.fr/>

WLAN Overview

QL 420 Printers can be equipped with a radio in the standard PCMCIA footprint using the industry standard 802.11 or 802.11b protocol. These printers will have the FCC I.D. number of the radio on the product label. They allow wireless communication as a node within a local area network, (LAN) and its wireless capabilities allow communications from any point within the LAN's perimeter. Methods of establishing communications to the QL 420 will vary with each LAN application.

QL 420 Network Printers printers with the PCMCIA module can be identified by the text "Network Printer" and FCC ID number *128-QL420352* on the front of the unit.

Methods of establishing communications to the QL 420 will vary with each LAN application. General information on establishing WLAN communications can be found in the Programmers Manual available on -line at:

<http://www.zebra.com/SS/manuals.htm>

More information and LAN configuration utilities may also be found in Zebra's Label Vista™ program (version 2.8 and later). Label Vista may be downloaded from the Zebra website at:

http://www.zebra.com/SD/product_LabelVista.htm

Setting Up the Software

The QL 420 uses Zebra's CPL Programming language which was designed for mobile printing applications. CPL is fully described in the Mobile Printing Systems Programming Manual, available on-line from Zebra's website at:

<http://www.zebra.com/SS/manuals.htm>

You can also use Label Vista™, Zebra's Windows™ based label creation program which uses a graphical interface to create and edit labels in the CPL language. Label Vista is available either on-line at Zebra's website, or on the Zebra accessories CD (part number 46984).

The QL 420 with its optional memory upgrade can support an interpreter for ZPL II®, the programming language used by Zebra desktop printers. To use ZPL II, refer to the ZPL II Programming Guide. If you choose to use a third party label preparation system, follow the installation instructions included in the package.

Using the Accessories

Belt Clip

Refer to Figure 14. The QL 420 is equipped with a belt clip. To use: hook the clip over your belt, and ensure that the clip is securely attached to the belt. The belt clip will pivot to allow you to move freely while wearing the printer.

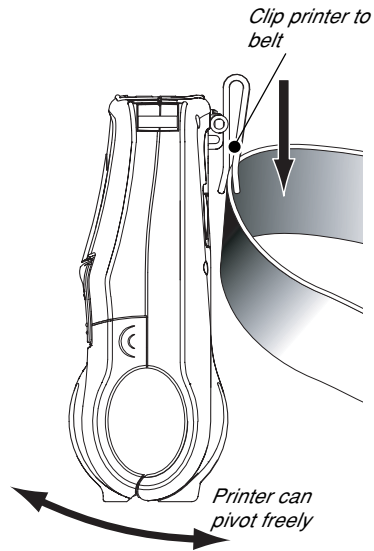

FIGURE 14: THE QL 420 BELT CLIP

Adjustable Shoulder Strap

Refer to Figure 15. If your printer is equipped for the shoulder strap option: snap each end of the shoulder strap into the "D" rings in the top of the printer. Slide the buckle away from or towards the printer until you achieve the desired length.

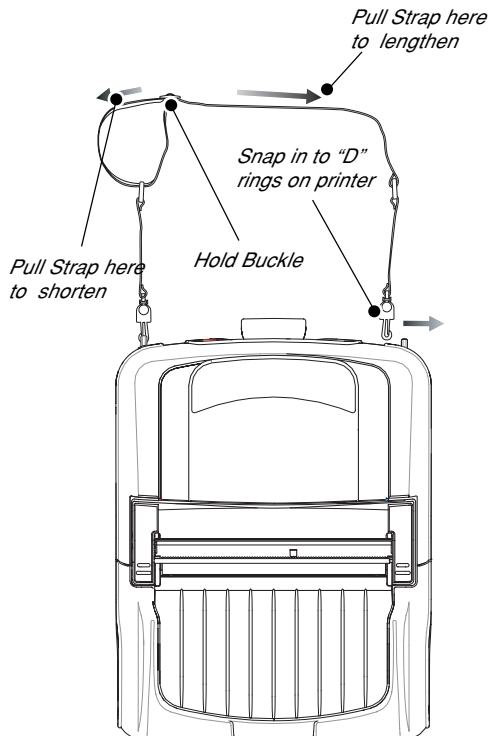

FIGURE 15: OPTIONAL SHOULDER STRAP

Preventive Maintenance

Extending Battery Life

- Never expose the battery to direct sunlight or temperatures over 104° F (40° C).
- Always use a Zebra charger designed specifically for Lithium-Ion batteries. Use of any other kind of charger may damage the battery.
- Choose the media that is easiest to “burn.” An authorized Zebra re-seller can help you determine the optimum media for your application.
- If you print the same text or graphic on every label, consider using a pre-printed label.
- Choose the correct print darkness, and print speed for your media.
- Use software handshaking (XON/XOFF) whenever possible.
- Select Tear-Off mode whenever possible (Peel-Off mode uses more power).
- If your printer has the optional LCD display, use the display backlight only when necessary. Turn it off whenever it is not needed.
- Pull the battery out of the printer if the printer won't be used for a day or more and you're not performing a maintenance charge.
- Consider purchasing an extra battery.
- Remember that any rechargeable battery will lose its ability to maintain a charge over time. It can only be recharged a finite number of times before it must be replaced.

continued on next page

Cleaning

⚠ CAUTION- Use only cleaning agents specified below. Zebra Technologies Corporation will not be responsible for damage caused by any other cleaning materials used on this printer.

Clean the printer with either the cleaning pen supplied with the printer or a cotton swab saturated with alcohol.

⚠ WARNING: To avoid possible personal injury or damage to the printer, never insert any pointed or sharp objects into the printer.

Area	Method	Interval
Printhead (Figure 16)	Use the supplied cleaning pen or 70% isopropyl alcohol on a cotton swab to clean the print elements from end to end (the print elements are located in the thin gray line on the printhead).	After every five rolls of media (or more often, if needed) Linerless media requires more frequent cleaning.
Platen Roller (Figure 16)	Rotate the platen roller and clean it thoroughly with the cleaning pen or 70% isopropyl alcohol and a cotton swab.	
	Units with linerless platens: Rotate platen & clean bearing points only. <i>Avoid use of alcohol on the surface of linerless platens!</i>	
Peel bar (Figure 16)	Clean thoroughly with the cleaning pen or 70% isopropyl alcohol and a cotton swab.	As needed
Tear bar (Figure 16)	Clean thoroughly with the cleaning pen or 70% isopropyl alcohol and a cotton swab.	
Exterior	Water-dampened cloth	
Interior (Figure 16)	Brush/air blow. Insure the Bar Sensor, Gap Sensor and Label Present Sensor windows are free of dust.	After every five rolls of media (or more often, if needed)
	Units with linerless platens: Clean inside surfaces of edge guides and media support rollers with the supplied cleaning pen or 70% isopropyl alcohol on a cotton swab.	
Media Rollers (Figure 16)	Clean thoroughly with the cleaning pen or 70% isopropyl alcohol and a cotton swab.	After every five rolls of media (or more often, if needed)
	Units with linerless platens: Rotate media rollers & clean bearing points only. <i>Avoid use of alcohol on the surface of the media rollers!</i>	

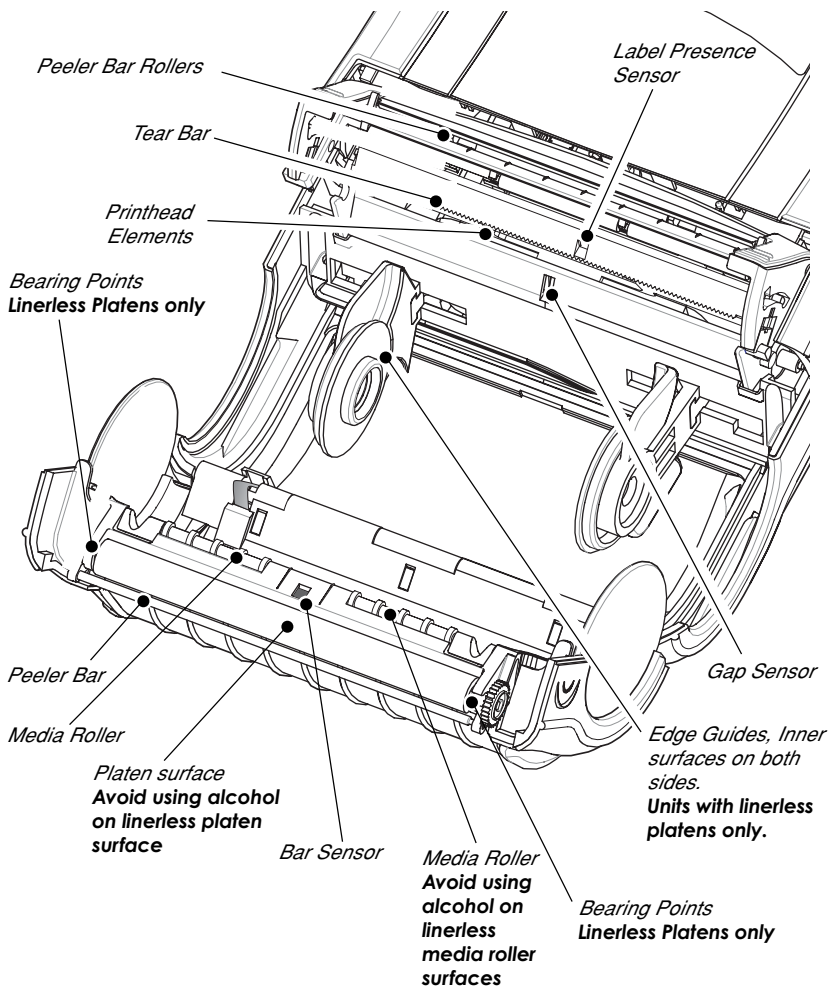

FIGURE 16: CLEANING THE QL 420

Troubleshooting





Standard Control Panel

If the printer is not functioning properly, refer to the chart below to find the state of the two LEDs on the Control Panel. Then refer to the Troubleshooting topic referenced in the chart to resolve the problem.

Green LED	Yellow LED	Indication	Ref. to Topic
Steady	Off	Normal Operation, and/or RF Link established	n/a
Off	Off	Power Off	1
Fast Blink	Off	No RF Link	6, 11
Slow Blink	Off	Low Battery	3, 6, 7
Steady	Steady	Out of media, or Media Cover not closed	9, 11
Steady	Fast Blink	Normal RF activity	8
Steady	Fast Blink, Beeper Sounds	No application	8

Optional LCD Control Panel

The top of the display shows several icons which indicate various printer functions. Check the indicator status, then refer to the Troubleshooting topic referenced in the chart to resolve the problem.

Status Icon	Condition	Indication	Ref. to Topic
	Steady	RF Link established	n/a
	Off	No RF Link	6
	Flashing	Low Battery	3, 6, 7
	Flashing	Head latch not closed	9, 11
	Flashing	Printer is receiving a file	8
	Flashing	Out of media,	9, 11
Blank Screen	n/a	No application	1, 13

Troubleshooting Topics

1. No power

- Check that battery is installed properly
- Recharge or replace battery as necessary.

2. Media does not feed:

- Be sure print head is closed and latched.
- Check spindle holding media for any binding.
- If unit is equipped with label presence sensor: Insure most recently printed label is removed. Also insure label sensor is not blocked.

3. Poor or faded print or flashing:

- Clean print head.
- Check battery and recharge or replace as necessary
- Check quality of media.

4. Partial/missing print:

- Check media alignment
- Clean print head.
- Insure printhead is properly closed and latched.

5. Garbled print:

- Check baud rate.

6. No print:

- Check baud rate
- Replace battery
- Check cable to terminal
- Establish RF Link (Wireless units only) or restore LAN associativity (QL 420N models only)
- Invalid label format or command structure — put printer in Communications Diagnostic (Hex Dump) Mode to diagnose problem.

7. Reduced battery life

- Check battery date code — if battery is one to two years old, short life may be due to normal aging.
- Recondition battery.
- Replace battery.

8. Yellow error light or flashing:

- No application or application corrupted: reload program.
- If using wireless communications: flashing indicator is normal while data is being transmitted or received.

continued on next page

9. Yellow error light always on,  or  flashing:

- Check media is loaded and print head is closed and securely latched.

10. Skips labels:

- Check media for top of form sense mark or label gap.
- Check that the maximum print field has not been exceeded on label.
- Insure bar/ or gap sensor is not blocked or malfunctioning

11. Communication Error:

- Check media is loaded, head is closed and error light is off.
- Check baud rate.
- Replace cable to terminal.

12. Label Jam:

- Open head release latch and media cover.
- Generously apply alcohol to printer in area of jammed label.

13. Blank LCD Screen (only for units with optional LCD control panel)

- No application loaded or application corrupted: reload program.

Troubleshooting Tests

Printing a Configuration Label

To print out a listing of the printer's current configuration follow these steps:

1. Turn the printer off. Load the media compartment with journal media (media with no black bars printed on the back)
2. Press and hold the Feed Button.
3. Press and release the Power button and keep the Feed button pressed. When printing starts, release the Feed button.

Sample Configuration Label

Print Head Test

Zebra QL 420 V79/00 09/06/02
CHK: FFFF XXQT01-12-0001
HTQ37923 /18
Testing Memory...
Memory tested and OK
Baud Rate: 19200 BPS
In-activity Timeout: 120 Secs
Low battery Shut-down: 168

End of report. ● *End of First Report*



XXQT01-12-0001 ● *Unit Serial Number*

Program:

Firmware: HTQ37923 /18 ● *Application Number*
Chksum: SE9F
Software: HTTST00a
Chksum: 7068

Ver: L4.R79.23.U998.B19.T19.A00

Cable Communications:
19200 BPS, N,8,1
Handshake: Xon-Xoff/hardware
DSR: 0

Wireless Communications: ●

Bluetooth: ●

.version	1.1.0
.date	03/20/02
.baud	57600
.device	printer
.mode	slave
.local_name	?
.authentication	off
.discoverable	on
.encryption	off
.address	00:80:37:16:85:6A

Report appears only on units with wireless options installed. Units with no wireless options will print an empty line and resume

This example has a Bluetooth™ module installed. (refer to pages 24-25 for more details.)



00803716856A

FIGURE 17: CONFIGURATION LABEL

continued on next page

Sample Configuration Label (continued)

Peripherals: ●

MCR 2.00
 LCD: Not installed
 module: 0x3F
 Other : 0F

Power Management:

In-activity Timeout:120 Secs
 Low-battery Timeout:60 Secs
 Remote(DTR) pwr-off:Enabled
 Voltage :8.03(206)
 Low-bat Warning :6.94(178)
 Low-bat Shut-down:6.55(168)

Memory(3):

Flash :1048575 Bytes ● Flash Memory Size
 RAM :1048575 Bytes

Label:

Width :376 dots, 47 mm
 Height:17319 dots, 2164 mm ● Maximum Label Size

Sensors: (Adj)

Pres [DAC:127, Thr:120, Cur: 10]
 Label Present
 Media [Cur:199]
 Gap [DAC: 3, Thr: 40, Cur:143]
 Bar [DAC:175, Thr: 80, Cur: 12]
 Temperature :167
 Voltage :8.07(207)

Resident Fonts:

Font	Sizes	Chars
0	0- 6	20-FF
1	0	20-80
2	0- 1	20-59
4	0- 7	20-FF
5	0- 3	20-FF
6	0	20-44
7	0- 1	20-FF

(ARI14BPT.CPF) 0 ● Resident Fonts

File Directory:

File	Size
APPL .BIN	248886
CONFIG .SYS	89
ARI14BPT.CPF	6803
RUN .BAT	190

770000 Bytes Free ● Pre-scaled font (.cpf) listed separately

Command Language:

CCL Key '!' [21]

End of report.

Files Loaded in Printer Memory (will include Pre-scaled or Scalable Fonts)

Amount of Memory Available

FIGURE 17A: CONFIGURATION LABEL

Communications Diagnostics

If there's a problem transferring data between the computer and the printer, try putting the printer in the Communications Diagnostics Mode (also referred to as the "DUMP" mode). The printer will print the ASCII characters and their and their text representation (or the period '.', if not a printable character) for any data received from the host computer

To enter Communications Diagnostics Mode:

1. Print a configuration label as described on pg. 37.
2. At the end of 2nd diagnostics report, the printer will print: "Press FEED key to enter DUMP mode".
3. Press the FEED key. The printer will print: "Entering DUMP mode".

Note: If the FEED key is not pressed within 3 seconds, the printer will print "DUMP mode not entered" and will resume normal operation.

4. At this point, the printer is in DUMP mode and will print the ASCII hex codes of any data sent to it, and their text representation (or "." if not a printable character).

Additionally, a file with a ".dmp" extension containing the ASCII information will be created and stored in the printer's memory. It can be viewed, "cloned" or deleted using the Label Vista application. (Refer the Label Vista documentation for more information.)

To terminate the Communications Diagnostics Mode and return the printer to normal operations:

1. Turn the printer OFF.
2. Wait 5 seconds.
3. Turn the printer ON.

Calling the Help Desk

If the printer fails to print the configuration label, or you encounter problems not covered in the Troubleshooting Guide, contact the Help Desk. Help Desk addresses and phone numbers for your area can be found in Appendix D of this manual. The Help Desk will need the following information:

- Model number/type (e.g. QL 420)
- Unit serial number (Found on the large label on the back of the printer, also found in the configuration label printout. Refer to Figure 17)
- Product Configuration Code (PCC) (15 digit number found on the small label on the back of the unit)

Specifications



NOTE.- Printer specifications are subject to change without notice.

Printing Specifications

Print Density	203 dots/inch (8 dots/mm)
Print Width	Up to 4.09" (103.8 mm)
Print Speed	3" per second (76.2 mm per second)
Print Head Life, calculated	1,964,160" (50 Km) nominal
Distance from Print Element to Top of Form	.571" (14.5 mm) 116 dots

Memory/Communications Specifications

Flash Memory	1 MB flash (standard)
SRAM Memory	1MB SRAM (standard)
Standard Communications	RS-232 serial port (8 Pin circular DIN connector) Configurable Baud rate (from 9600 to 57.6 Kbps), parity and data bits. Software (X-ON/X-OFF) or hardware (DTR/STR) communication handshake protocols.
Optional Wireless Communications	Infrared wireless link (meets IrDA 1.1 communications specifications) 2,400 to 115,200 Baud rate* Bluetooth compatible 2.4 GHz SRRF link Optional wireless LAN capabilities comply with 802.11 and 802.11b protocols*

* The IR and WLAN options have not been released at time of printing.

Label Specifications

Label/Tag Width	2" to 4.1" (50.8 mm to 104.1 mm)
Max. Label/Tag Length	20" (508 mm) with standard memory
Inter-label Gap.	.08" to .16" (.12" preferred) 2 mm to 4 mm (3 mm preferred)
Label Thickness Tag Thickness	.0025" to .0065" (.064 mm to .165 mm) .0060" (.152 mm) maximum
Label Roll Size: Max. Diameter	2.625" (66.7 mm) O.D.
Inner Core Diameter	.75" (19 mm) minimum; 1.38" (35.05 mm) minimum for linerless media Use Zebra-brand direct thermal media that is outside wound. Media may be reflective (black mark) sensing or transmissive (gap) sensing, die-cut, continuous, fanfold or linerless. For die-cut labels, use only full auto dies.
Media Requirements	The reflective media black marks should extend past the centerline of the roll. Black Mark Dimensions: Minimum mark width: 0.5" (12.7mm) perpendicular to edge of media, centered within the width of the roll. Mark length: 0.094" (2.4 mm) parallel to edge of media

Font/Bar Code Specifications

Fonts Available	Five resident scalable and rotatable fonts available from 12-48 pt. Downloadable pre-scaled fonts via Label Vista™ software Optional international character sets
1D Bar Codes Available	Codabar UCC/EAN 128 Code 39 Code 93 EAN 8/JAN 8, 2 and 5 digit extensions EAN 13/JAN 13, 2 and 5 digit extensions Interleaved 2 of 5 MSI/Plessey FIM/POSTNET UPC-A, 2 and 5 digit extensions UPC E, 2 and 5 digit extensions
2D Bar Codes Available	MaxiCode PDF 417
Rotation Angles	0°, 90°, 180°, and 270°

Physical/Environmental/Electrical Specifications

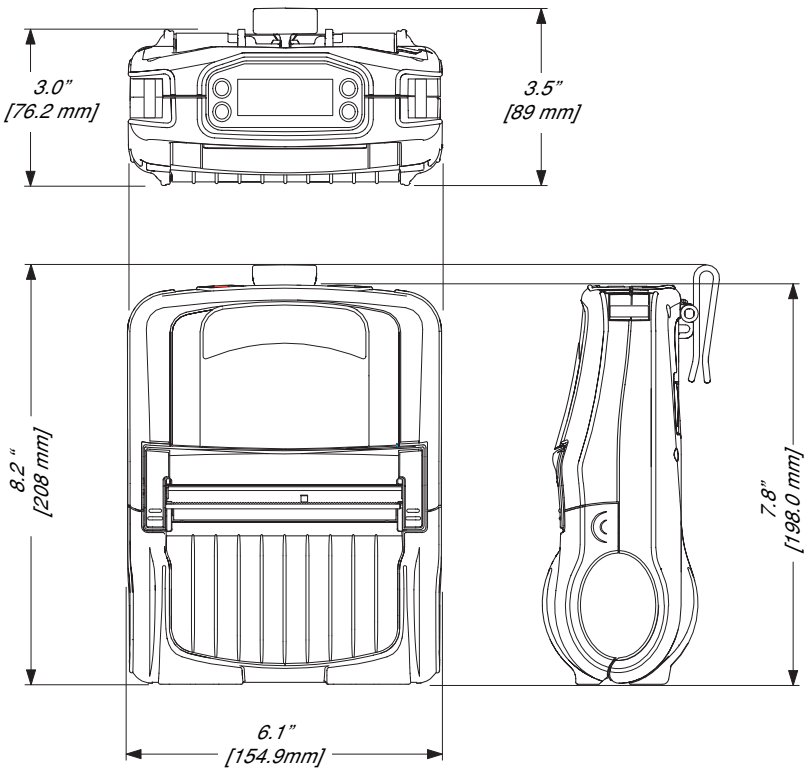
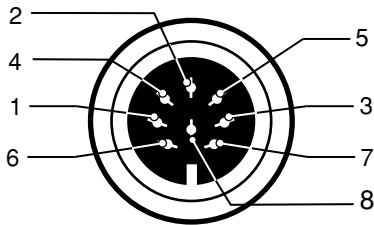

FIGURE 18 OVERALL DIMENSIONS

Weight w/ battery, excluding media & wireless options.	2.0 lbs. (.9 kg.)
Temperature Operating Storage	5° to 122° F (-15° to 50° C) -13° to 158° F (-25° to 70° C) Range
Relative Humidity Operation Storage	10% to 80% (non-condensing) 10% to 90% (non-condensing)
Electrical	Battery: 7.4V (nominal) Lithium-Ion Chargers: External single battery charger Model LI72, 120-230 VAC depending on model selected. External 4-bay charger Model UCLI72-4, 120 VAC

Communications Port

Pin#	Signal Name	Type	Description
1	RXD	input	Receive Data
2	TXD	output	Transmit Data
3	CTS	input	Clear To Send from host
4	RTS	output	Request To Send set high when printer is ready to accept command /data
5	GND		Ground
6	NC		No Connect
7	DSR	input	Data Set Ready low to high transition turns printer on, high to low transition turns printer off (if enabled)
8	DTR	output	Data Terminal Ready set high when printer is on (set to battery voltage for "S" versions)



*FIGURE 19 COMMUNICATIONS PORT
(8 pin Circular DIN)*

continued on next page

Accessories

- Adjustable shoulder strap
- Protective soft case
- Extra battery packs
- 120-230 VAC battery charger
- Quad Charger
- Desk Mount
- Vehicular Mount w/ external fanfold media storage
- DC-DC run/charge units (input ranges from 12 to 60 VDC)
- AC run/charge unit (110 to 240 VAC input)
- Data cables

For details, call your authorized Zebra re-seller.

Appendices



Appendix A

Interface Cables

Part Number BL11757-000; 8-Pin DIN to 9-Pin DB PC Cable

This part is also available as a coiled cable under Part Number BL15063-1.

For Use With a Personal Computer

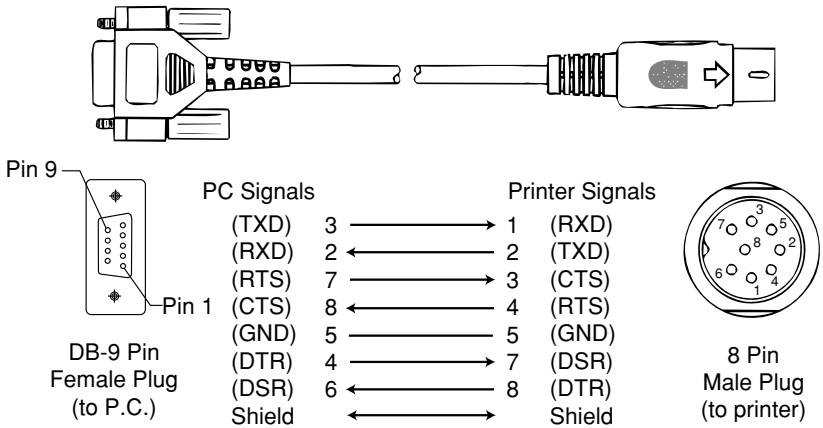

Appendix A

INTERFACE CABLES

Terminal	Cable Part Number	Cord Lgth/Type	Terminal Connector	Printer Connector	Notes
COMPSEE Apex II, III	BL12093-3	8' Coiled	MOD 10	8 Pin DIN	
COMPAQ (IPAQ) H3100, H3600, H3700 H3800	BL16386-1 BL16470-1	4' straight 4' straight	Foxconn 12 pin Foxconn 22 pin	8 Pin DIN 8 Pin DIN	
HANDHELD PRODUCTS 7500	BL11757-000	6'/Straight	9 Pin DB	8 Pin DIN	
LXE MX1, MX3 1380, 1390, 1590 2325	BL17757-000 BL17757-000 BL12093-1	6'/Straight 6'/Straight 8'/Coiled	9 Pin DB 9 Pin DB RJ45	8 Pin DIN 8 Pin DIN 8 Pin DIN	Power On/Off (+5V)
NORAND/INTERMEC RT1100/1700 Series	BL11537-1 BL11537-2 BL13309-1 BL12804-1 BL13298-1 BL12803-1	8' /Coiled 12'/Coiled 8' /Coiled 8' /Coiled 8' /Coiled 8' /Coiled	6 Pin MiniDIN 6 Pin MiniDIN 6 Pin Mini DIN 6 Pin MiniDIN 6 Pin MiniDIN 15 Pin D-Sub	8 Pin DIN Over-molded 8 Pin DIN Over-molded 8Pin DIN 8 Pin DIN -Locking 8 Pin DIN Over-molded 8 Pin DIN	Auto ON/OFF Auto ON/OFF
RT1700 Series	BL11757-000 BL11757-000 BL11757-000	6'/Straight 6'/Straight 6'/Straight	9 Pin DB 9 Pin DB 9 Pin DB	8 Pin DIN 8 Pin DIN 8 Pin DIN	w/optical link adapter Intermecc# 064021 no auto power
RT5900 Series 6400 242X 243X	BL11537-1 BL11537-2 BL11757-000 BL11757-000 BL11757-000	8'/coiled 12'/coiled 6'/Straight 6'/Straight 6'/Straight	6 pin Mini DIN 6 pin Mini DIN 9 Pin DB 9 Pin DB 9 Pin DB	8 pin DIN 8 pin DIN 8 Pin DIN 8 Pin DIN 8 Pin DIN	w/intermed serial adapter w/ serial pod
502X 6110 6640,665X, 248X 5055	BL11757-000 BL11757-000 BL11757-000 BL11757-000	6'/Straight 6'/Straight 6'/Straight 6'/Straight	9 Pin DB 9 Pin DB 9 Pin DB 9 Pin DB	8 Pin DIN 8 Pin DIN 8 Pin DIN 8 Pin DIN	COM1 Auto Power (DTR)

Appendix A

INTERFACE CABLES (continued)

Terminal	Cable Part Number	Cord Lgth/Type	Terminal Connector	Printer Connector	Notes
SYMBOL/TELEXON					
FMT 1000, 3000	BL11757-000	6' /Straight	9 Pin DB Fem.	8 Pin DIN	Auto Power (DTR)
PDT3300 Series	BL11391-000	8' /Coiled	DB25 male	8 Pin DIN	Auto Power (DTR)
	BL12093-2	8' coiled	MOD 10	8 Pin DIN	Auto Power (+5V)
PDT3100, 3200, 3500	BL12093-1	8' /Coiled	MOD 10	8 Pin DIN	Auto Power (+5V)
6100	BL10293-2	8' /Coiled	MOD 10	8 Pin DIN	Auto Power(DTR)
SPT1700, 1800	BL15483-1	9' /Coiled	Clip-on	8 Pin DIN	
	BL15483-3	9' /Coiled	Clip-on	8 Pin DIN	Auto Power Pin 1 (+5 V)
PPT2700, 2800	BL15482-1	9' /Coiled	Cradle	8 Pin DIN	Power On/Off (DTR Line)
PDT3800, 6800	CC11371-3	6' /Coiled	PIM LPT	8 Pin DIN	
	CC11371-14	6' / Coiled	PIM COM	8 Pin DIN	
	CC11371-15	6' / Coiled	PIM COM	8 Pin DIN	Auto Power (DTR)
	CC11371-14	6' / Coiled	PIM LPT	8 Pin DIN	"S" Printers Only
LRT/LDT3800					
& 6800 Series	CC11371-15	6' / Coiled	PIM Optical	8 Pin DIN	"S" Printers Only
LRT/LDT3800					
& 6800 Series	BL11122-1	8' /Coiled	MOD 8	8 Pin DIN	Auto Power (DTR)
PTC960X	CC17711-1	n/a	Micro DB-15	8 Pin DIN	Adapter for BL11122-1
PTC960L, 960SL	CP74005	8' /Coiled	Micro DB-15	8 Pin DIN	BL11122-1 & CC13711-1 (Kit)
960RL, 960M, 1134					
2134, 2234					
PTC 510, 610, 710	CL11314-000	8' /Coiled	DB25F	8 Pin DIN	Auto Power (DTR)
860, 912					
PTC 860IM, 870IM	BL13237-1	6' /Straight	Fischer-11	8 Pin DIN	Auto Power (DTR)
PTC1124, 2124	BL11757-1	6' /Straight	DB-9M	8 Pin DIN	uses serial pod
PTC1184	CL12628-1	8' / Coiled	Mini DIN-8F	8 Pin DIN	
PTC1194	BL11757-1	6' /Straight	DB-9M	8 Pin DIN	Auto-power (DTR)
VRC 3900	CL11314-000	8' /Coiled	DB-25F	8 Pin DIN	Auto Power (DTR)
VRC4000.5000	BL11757-1	6' /Straight	DB-9M	8 Pin DIN	Auto Power (DTR)
VRC 69XX	BL16014-1	10' /Straight	Fischer-16	8 Pin DIN	Auto Power (DTR)

Appendix A

INTERFACE CABLES (continued)

Terminal	Cable Part Number	Cord Lgth/Type	Terminal Connector	Printer Connector	Notes
TEKLOGIC 7025 7030 7035 8255, 8260 8510	BL13285-1	8'/Coiled	DB-15M	8 Pin DIN	
	BL13285-2	8'/Coiled	Honda-36M	8 Pin DIN	Auto Power (7.5V)
	BL16469-1	8'/Coiled	Honda-28M	8 Pin DIN	Auto Power (7.5V)
	BL16469-1	8'/Coiled	Honda-28M	8 Pin DIN	Auto Power (12V)
	BL11757-1	6'/Straight	DB-9M	8 Pin DIN	Auto-power (DTR)
UNITECH PT-500, 700, 805, 815	BL11757-1	6'/Straight	DB-9M	8 Pin DIN	Auto-power (DTR)

Appendix B

Media Supplies

To insure maximum printer life and consistent print quality and performance for your individual application, it is recommended that only media produced by Zebra be used. Advantages include:

- Consistent quality and reliability of media products.
- Large range of stocked and standard formats.
- In-house custom format design service.
- Large production capacity which services the needs of many large and small media consumers including major retail chains world wide.
- Media products that meet or exceed industry standards.

For more information call Zebra Technologies Corporation at +1.866.230.9495 (U.S., Canada and Mexico) and ask to speak to a Media Sales Representative.

Appendix C

Maintenance Supplies

In addition to using quality media provided by Zebra, it is recommended that the printer be cleaned as prescribed in the maintenance section. The following items are available for this purpose:

- Cleaning Pen (10 pack), Reorder No. AN11209-1
- Cleaning Kit with Cleaning Pen, and Cotton Swabs, Reorder No. AT702-1

Appendix D

Product Support

When calling with a specific problem regarding your printer, please have the following information on hand:

- Model number/type (e.g. QL 320)
- Unit serial number (Found on the large label on the back of the printer)
- Product Configuration Code (PCC) (15 digit number found on the small label on the back of the unit)

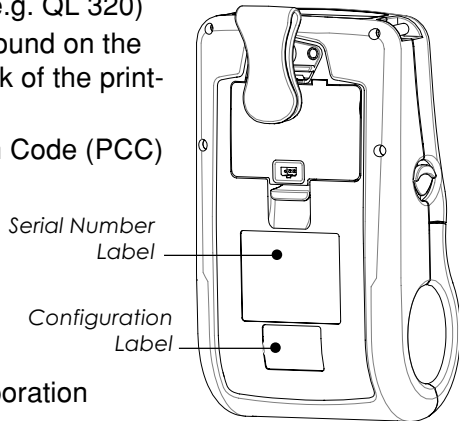

QL 320 SHOWN

Contact the Help Desk at:

Zebra Technologies Corporation
30 Plan Way

Warwick, Rhode Island 02886-1012 USA

Telephone: +1 401.739.5800

Fax: +1 401.732.7808

e-mail: risupport@zebra.com

In Europe:

Zebra Technologies Europe, Limited

Zebra House

The Valley Centre, Gordon Road

High Wycombe

Buckinghamshire HP13 6EQ, United Kingdom

Telephone: +44 1494 768298

Fax: +44 1494 768210

e-mail: tseurope@zebra.com

Ask for Customer Support

Index

- A
 - Accessories 44
- B
 - Battery, charging 9
 - while printing 9
 - Battery, installing 9
 - Battery life, tips 31
 - Belt clip 30
 - Bluetooth Device Address (BDA). *See*
 - Communications: wireless via Bluetooth™
- C
 - Charger, battery
 - LI 72 (single charger) 9
 - quad charger charging times 10
 - quad charger indicators 10
 - UCLI72-4 Quad Charger 10
 - Cleaning
 - edge guides 32
 - Exterior 32
 - Interior 32
 - Linerless platen roller 32
 - Peel bar 32
 - Platen roller 32
 - Printhead 32
 - Sensors 32
 - Tear bar 32
 - Communications
 - Connector signals 43
 - infrared (IR) 23
 - SRRF
 - Bluetooth™ 25
 - with a cable 22
 - Communications diagnostics 39
 - Configuration label 36
 - sample printout 37, 38
- D
 - Damage, shipping 7
 - Declaration of Conformity
 - EU countries 27
- H
 - Help Desk, contacting 39
- L
 - Label Vista 20, 28, 29
 - use in troubleshooting 39
- LAN. *See* Wireless communication:
- Local Area Network
- M
 - Manual
 - CPL Programming 7, 28, 29
 - ZPL II Programming 7, 29
- Media, loading 12
 - fan-fold media 14
 - media spacer, use of 14
 - peel-off mode 15
 - tear-off mode 15
- O
 - Operator Controls 16
 - LCD Keypad 18
 - functions displayed 20
 - Standard Keypad 16
 - error indicator 17
 - power-on indicator 16
- P
 - piconet. *See* Communications: wireless via Bluetooth™
 - Platen
 - linerless 32
 - Programming language
 - CPL 7
 - ZPL II 29
 - interpreter for 7
- Q
 - QuickLink™ module 16, 17
- R
 - Regulatory Information
 - Bluetooth radio 24
 - CF WLAN radio 26
 - PCMCIA WLAN radio 27
- S
 - Safety
 - placement of charger 11
 - while charging batteries 11
 - Shoulder Strap, adjusting 30
 - Software 29
 - Specifications
 - Font/bar Code 41
 - Label 41
 - Memory/communications 40
 - Physical 42
 - printing 40
- T
 - Troubleshooting
 - entering Communications Diagnostics Mode 39
 - terminating Communications Diagnostics Mode 39
 - LCD Control Panel 34
 - Standard control panel indicators 34
 - Troubleshooting tests 36
 - printing a configuration label 21
 - Troubleshooting Topics 35
- V
 - Wireless communication
 - Bluetooth™ 24
 - Infrared (IrDA) 23
 - Local Area Network 16
 - Local Area Network using CF Radio 26
 - Local Area Network using PCMCIA Radio 27

Patent Information

This product and/or its use may be covered by one or more of the following US patents and corresponding international patents worldwide

D275,286	5,029,183	5,364,133	5,543,610	6,034,708
D347,021	5,047,617	5,367,151	5,545,889	6,036,383
D389,178	5,103,461	5,372,439	5,552,592	6,057,870
D430,199	5,113,445	5,373,148	5,570,123	6,068,415
D433,702	5,140,144	5,378,882	5,578,810	6,070,805
3,964,673	5,132,709	5,396,053	5,589,680	6,095,704
4,019,676	5,142,550	5,396,055	5,612,531	6,109,801
4,044,946	5,149,950	5,399,846	5,642,666	6,123,471
4,360,798	5,157,687	5,408,081	5,657,066	6,147,767
4,369,361	5,168,148	5,410,139	5,768,991	6,151,037
4,387,297	5,168,149	5,410,140	5,790,162	6,201,255 B1
4,460,120	5,180,904	5,412,198	5,791,796	6,231,253 B1
4,496,831	5,229,591	5,415,482	5,806,993	6,261,009
4,593,186	5,230,088	5,418,812	5,813,343	6,261,013
4,607,156	5,235,167	5,420,411	5,816,718	6,267,521
4,673,805	5,243,655	5,436,440	5,820,279	6,270,072 B1
4,736,095	5,247,162	5,444,231	5,848,848	6,285,845 B1
4,758,717	5,250,791	5,449,891	5,860,753	6,292,595
4,816,660	5,250,792	5,449,893	5,872,585	6,296,032
4,845,350	5,262,627	5,468,949	5,874,980	6,364,550
4,896,026	5,267,800	5,479,000	5,909,233	6,379,058 B1
4,897,532	5,280,163	5,479,002	5,976,720	6,409,401 B1
4,923,281	5,280,164	5,479,441	5,978,004	6,411,397 B1
4,933,538	5,280,498	5,486,057	5,995,128	6,428,227 B2
4,992,717	5,304,786	5,503,483	5,997,193	
5,015,833	5,304,788	5,504,322	6,004,053	
5,017,765	5,321,246	5,528,621	6,010,257	
5,021,641	5,335,170	5,532,469	6,020,906	



Zebra Technologies Corporation

Mobile Printer Center of Excellence
30 Plan Way
Warwick, RI 02886.1012 U.S.A.
Telephone: +1 401.739.5800
 + 1 800.556.7266
Facsimile: +1 401.732.7808

Zebra Technologies Europe Limited

Zebra House
The Valley Centre, Gordon Road
High Wycombe
Buckinghamshire HP13 6EQ, UK
Telephone: +44 (0) 1494 472872
Facsimile: +44 (0) 1494 450103
visit our Web site at www.zebra.com

