

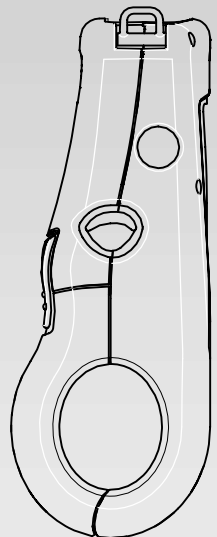

QL 320tm

Mobile Printer User's Guide

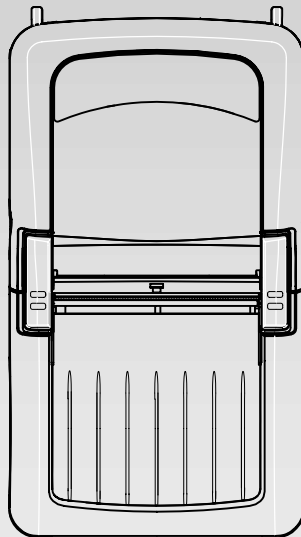
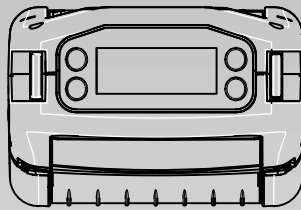

Proprietary Statement

This manual contains proprietary information of Zebra Technologies Corporation. It is intended solely for the information and use of parties operating and maintaining the equipment described herein. Such proprietary information may not be used, reproduced, or disclosed to any other parties for any other purpose without the expressed written permission of Zebra Technologies Corporation.

Product Improvements

Since continuous product improvement is a policy of Zebra Technologies Corporation, all specifications and signs are subject to change without notice.

FCC Compliance Statement

NOTE: This equipment has been tested and found to comply with the limits for a Class B digital device, pursuant to Part 15 of FCC Rules. These limits are designed to provide reasonable protection against harmful interference when the equipment is operated in a commercial environment. This equipment generates, uses, and can radiate radio frequency energy and, if not installed and used in accordance with the instruction manual, may cause harmful interference to radio communications. Operation of this equipment in a residential area is likely to cause harmful interference in which case the user will be required to correct the interference at his own expense.

WARNING: Exposure to Radio Frequency radiation. To conform to FCC RF exposure requirements this device shall be used in accordance with the operating conditions and instructions listed in this manual. Note that there are several radio options available with this printer. Additional regulatory information is contained in later sections devoted to each radio type.

NOTE: This unit was tested with shielded cables on the peripheral devices. Shielded cables must be used with the unit to insure compliance

Changes or modifications to this unit not expressly approved by Zebra Technologies Corporation could void the user's authority to operate this equipment.

Canadian Compliance Statement

"IC:" before the equipment certification number signifies that the Industry Canada technical specifications were met. It does not guarantee that the certified product will operate to the user's satisfaction.

Liability Disclaimer

Inasmuch as every effort has been made to supply accurate information in this manual, Zebra Technologies Corporation is not liable for any erroneous information or omissions. Zebra Technologies Corporation reserves the right to correct any such errors and disclaims liability resulting therefrom.

No Liability for Consequential Damage

In no event shall Zebra Technologies Corporation or anyone else involved in the creation, production, or delivery of the accompanying product (including hardware and software) be liable for any damages whatsoever (including, without limitation, damages for loss of business profits, business interruption, loss of business information, or other pecuniary loss) arising out of the use of or the results of use of or inability to use such product, even if Zebra Technologies Corporation has been advised of the possibility of such damages. Because some states do not allow the exclusion of liability for consequential or incidental damages, the above limitation may not apply to you.

Copyrights

The copyrights in this manual and the system described therein are owned by Zebra Technologies Corporation. All rights are reserved. Unauthorized reproduction of this manual or the software in any of the system modules may result in imprisonment of up to one year and fines of up to \$10,000 (17 U.S.C.506). Copyright violators may be subject to civil liability.

All products and brand names are trademarks of their respective companies. All rights reserved.

©2002 Zebra Technologies Corporation



QL 320tm

Mobile Printer
User's Guide

Contents

Introduction	7
Unpacking and Inspection	7
Reporting Damage	7
Getting Ready to Print	9
Battery	9
<i>Installing the Battery</i>	9
<i>Charging the Battery</i>	9
Loading the Media	10
<i>Installing the Media</i>	10
Operator Controls	13
<i>Standard Keypad</i>	13
<i>LCD Control Panel</i>	15
Verify the Printer Is Working	18
<i>Printing a Configuration Label</i>	18
Connecting the Printer	18
<i>Cable Communications</i>	19
<i>IR Communications</i>	20
<i>SRRF Communications</i>	21
<i>Zebra SRRF Network Overview</i>	21
<i>Bluetooth™ Networking Overview</i>	22
<i>Wireless Local Area Network (WLAN) Module Using CF</i> <i>Radio</i>	24
<i>Wireless Local Area Network (WLAN) Module Using</i> <i>PCMCIA Radio</i>	25
Setting Up the Software	26
Adjustable Shoulder Strap	27
Belt Clip	28
Preventive Maintenance	29
Extending Battery Life	29
Cleaning	31
Troubleshooting	32
Standard Control Panel	32
Optional LCD Control Panel	32
Troubleshooting Topics	
Troubleshooting Tests	34
<i>Printing a Configuration Label</i>	34
<i>Sample Configuration Label</i>	35
<i>Communications Diagnostics</i>	37
<i>Calling the Help Desk</i>	37

Specifications	38
Printing Specifications	38
Memory/Communications Specifications	38
Label Specifications	39
Font/Bar Code Specifications	39
Physical/Environmental/Electrical Specifications	40
Communications Port	41
.....	41
Agency Approvals	42
Accessories	42
Appendix A	43
Interface Cables	
Appendix B	46
Media Supplies	
Appendix C	47
Maintenance Supplies	
Appendix D	48
Product Support	
Index	49
Patent Information	inside back cover

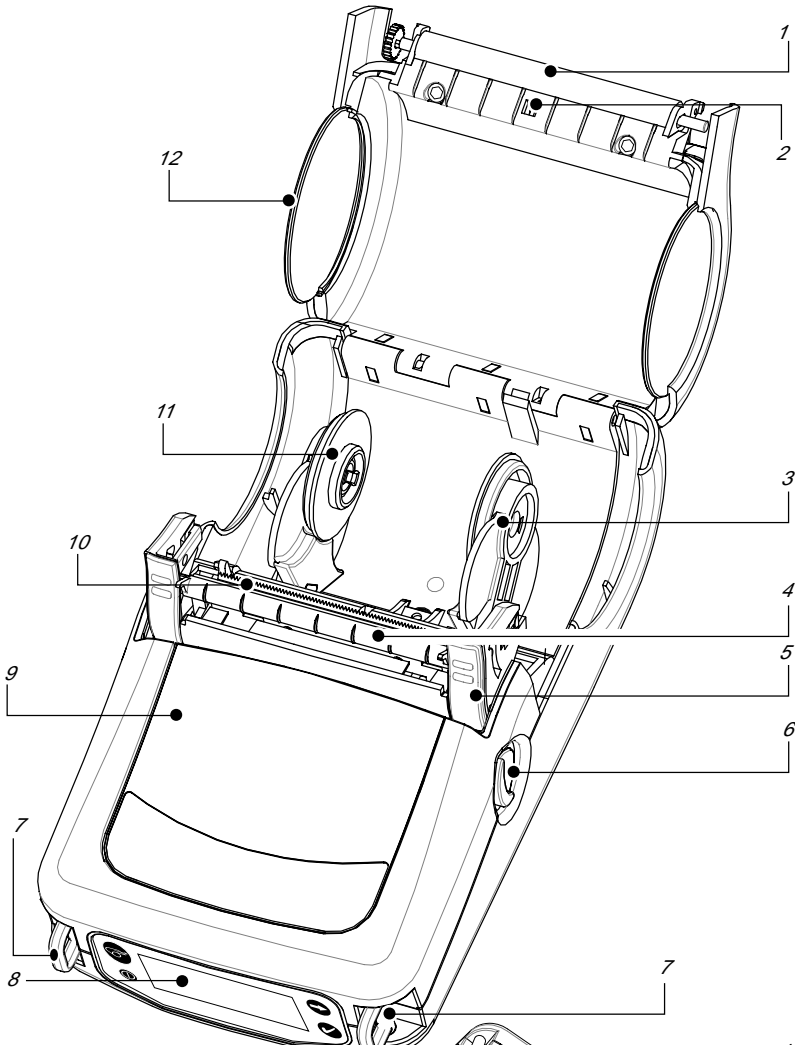

- 1 Platen Roller
- 2 Bar Sensor
- 3 Media Support
- 4 "EZ-Peel" Peeler
- 5 Latch
- 6 Latch Release Lever
- 7 "D" Rings
- 8 Control Panel
- 9 QuickLink™ Module
- 10 Print Head
- 11 Media Support Disks
- 12 Media Cover

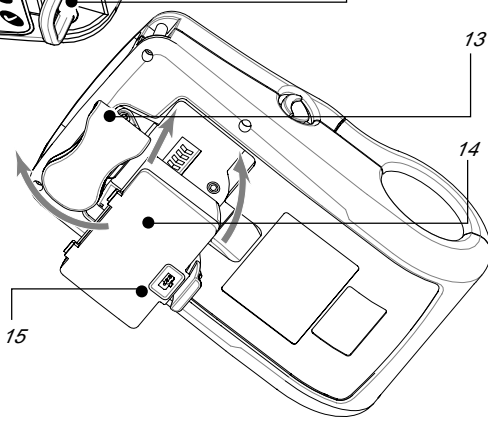

- 13 Belt Clip
- 14 Battery
- 15 Battery Charging Receptacle

Introduction

Thank you for choosing our Zebra QL 320 Mobile Printer. This rugged printer is sure to become a productive and efficient addition to your workplace thanks to its innovative design. Because it's made by Zebra Technologies Corporation, you're assured of world-class support for all of your bar code printers, software, and supplies.

- This user's guide gives you all the information you'll need to operate the QL 320 printer.
- The QL 320 uses the CPL programming language. To create and print labels using the CPL language, refer to the Mobile Printer Programming Guide (available on our website at: <http://www.zebra.com/SS/manuals.htm>) and our Label Vista™ label creation program.
- The QL 320 has an optional interpreter for the ZPL II® Programming Language which interprets commands up to X.8 firmware. The printer must be equipped with the optional memory upgrade and appropriate application in order to use this function. A ZPL II Program Guide (part #46530L) can be used as reference for the ZPL II label design programming language. If either manual was not ordered with the printer, simply call your re-seller or Zebra Technologies Corporation or visit the Zebra web site.

Unpacking and Inspection

Inspect the printer for possible shipping damage:

- Check all exterior surfaces for damage.
- Open the media cover (refer to "Loading the Media" in the Getting Ready to Print section) and inspect the media compartment for damage.

In case shipping is required, save the carton and all packing material.

Reporting Damage

If you discover shipping damage:

- Immediately notify and file a damage report with the shipping company. Zebra Technologies Corporation is not responsible for any damage incurred during shipment of the printer and will not cover the repair of this damage under its warranty policy.
- Keep the carton and all packing material for inspection.
- Notify your authorized Zebra re-seller.

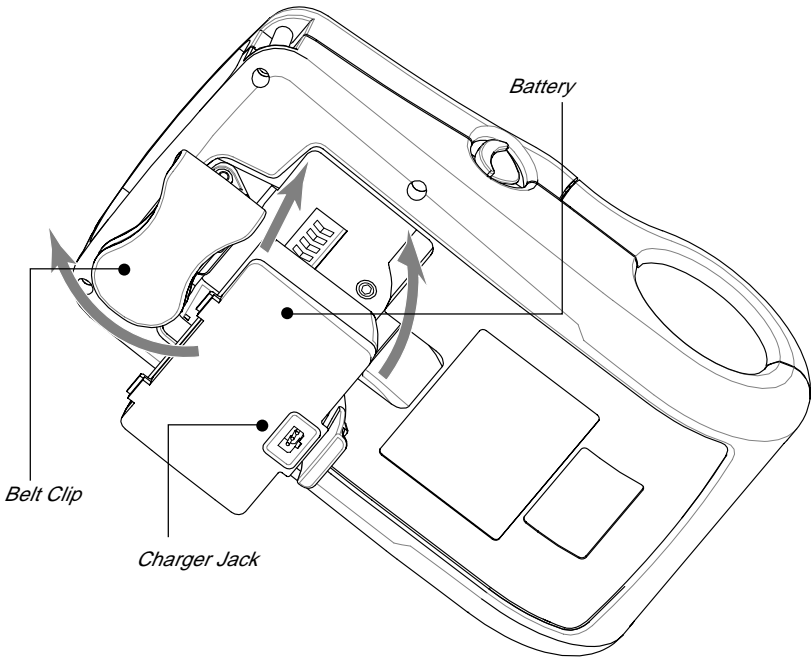

FIGURE 2

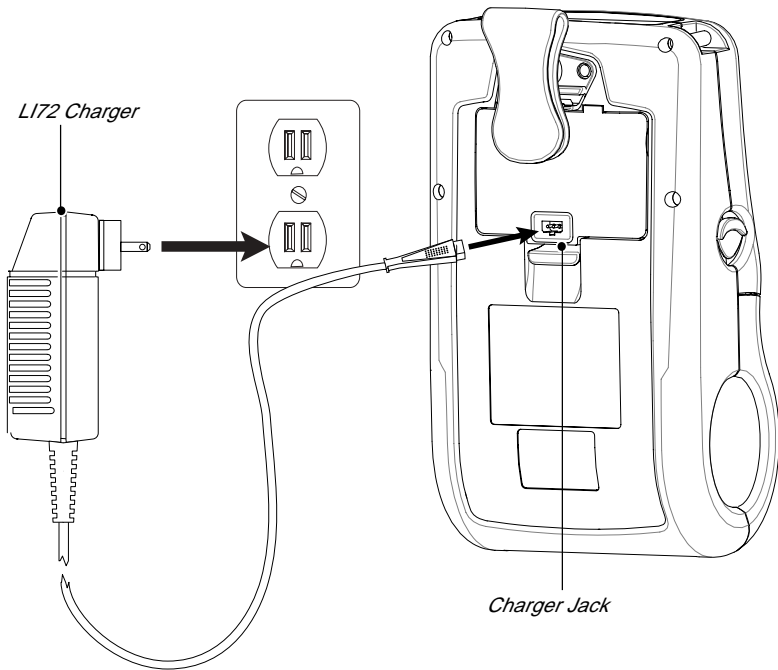

FIGURE 3

Getting Ready to Print

Battery

Installing the Battery



NOTE: Batteries are shipped uncharged. Remove protective shrink-wrap and labels from new battery packs prior to use.

1. If the printer is so equipped, rotate the Belt Clip to allow access to the Battery compartment.
2. Insert the battery into the printer as shown in Figure 2,
3. Rock the Battery into the printer as shown until it locks in place.

When the battery is first installed, the Control Panel indicators may briefly turn on and then go off which indicates the battery is not fully charged (see “Charging the Battery” below and “Operator Controls”).

Charging the Battery

Refer to Figure 3. Your battery charger may look slightly different from the ones illustrated.

If you are using the LI 72 battery charger:

1. Install the battery in the printer and plug the Charger into the appropriate A.C. wall receptacle. Then insert the charge cable into the battery charger jack.
2. The charger LED will indicate the status of the charger as follows:
 - A steady light indicates the battery is undergoing a fast charge.
 - A slow blinking light indicates the charger is in trickle mode. The battery is ready for use.
 - A rapidly blinking light indicates a problem with the battery. The battery may have an internal short, or its charge monitoring circuitry may be malfunctioning. The battery should not be used any further.
 - Battery Packs may be charged either when installed in the printer or when removed.



Do not attempt to charge batteries with the LI 72 while printing. Attempting to print while charging can result in improperly charged batteries.

Loading the Media

You can operate this printer in one of two different modes: Tear-Off or Peel-Off. Tear-Off mode allows you to tear off each label (or a strip of labels) after it is printed. In Peel-Off mode, the backing material is peeled away from the label as it is printed. After you remove this label, the next one is printed.

Installing the Media

1. Open the printer: Refer to Figure 4.

- Rotate the latch release levers on each side of the printer as shown at “1” below.

The latch assembly will flip open automatically as shown at “2”.

- Rotate the media Cover back as shown at “3”, exposing the media compartment and the adjustable media supports.

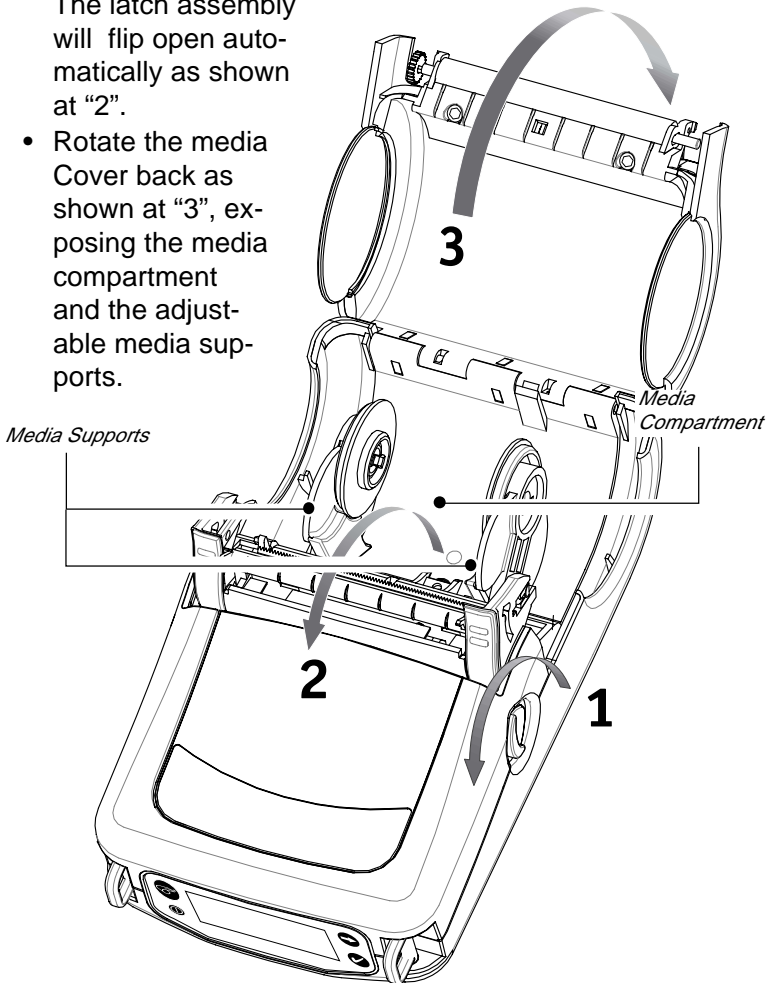

FIGURE 4

2. Load the media: Refer to Figure 5.

- Determine that the core diameter of the media roll matches the setting of the Media Disks. If it does not, adjust the media disks per Figure 6 below.
- If the media support setting is correct, pull the media supports apart, insert the roll of media between them, and let the media supports close. Insure that the media pulls off the core in the direction shown in Figure 5. The supports will adjust themselves to the width of the media, and the media should be able to spin freely on the supports.

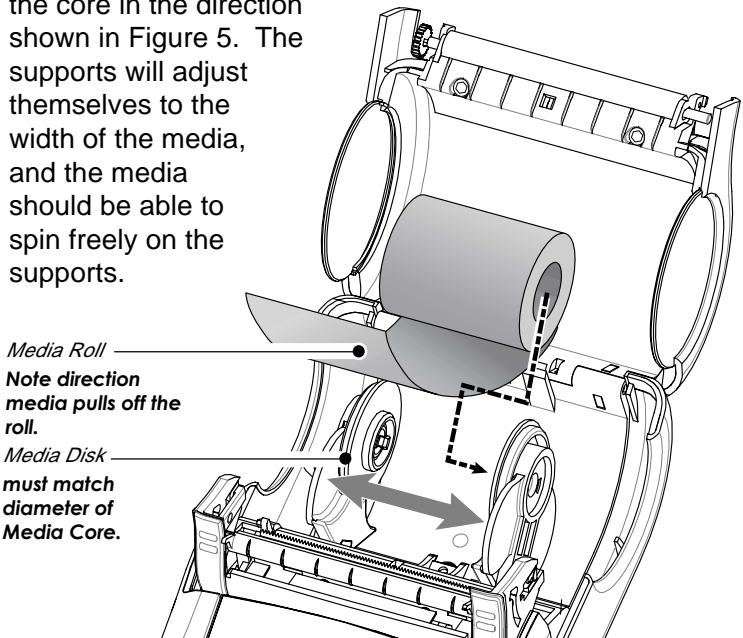

FIGURE 5

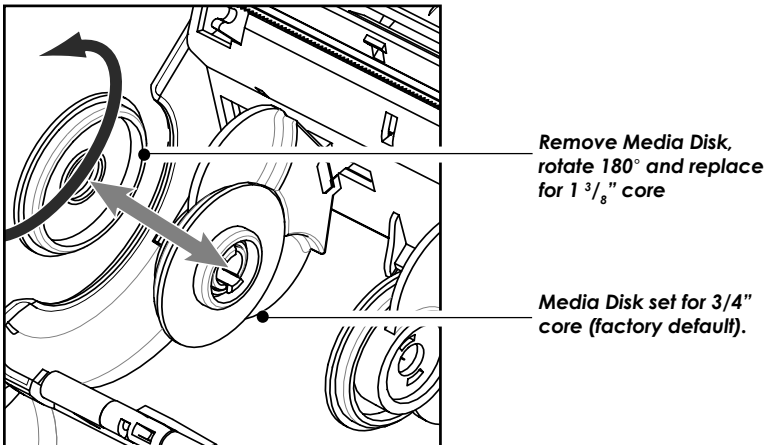

FIGURE 6

continued on next page

3. Refer to Figure 7. Close the Media Cover

- If you plan to use the printer in the tear-off mode, close the media cover as shown at “2”, then rotate the latch assembly as shown until it locks into place, as shown at “4”.
- If you plan to use the printer in the peel-off mode, peel a few labels off of the media roll and pull it out of the printer as shown at “1”. Close the media cover as shown at “2”. Rotate the “EZ-Peel” peeler bar until it locks into place on the latch, as shown at “3”, then rotate the Latch as shown until it locks into place, as shown at “4”.
- Turn on the printer or press the Feed button if the printer is already on.

The printer will advance the media to the next label, if printing labels. If you are printing on journal media, the printer will advance a short strip of media and will then be ready for printing.

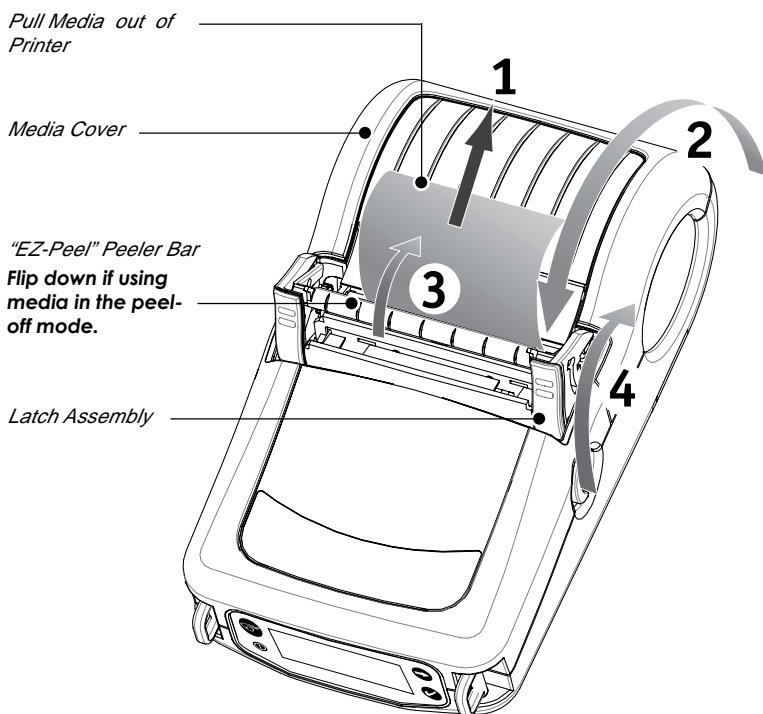

FIGURE 7

Operator Controls

The QL 320 will come with one of two possible control panels. The standard control panel is detailed below and in Figure 8. The optional control panel (Figure 9) features an LCD which allows easy display and selection of many printer functions and is detailed on following pages.

Standard Keypad

The standard keypad has three control buttons and two multi-purpose indicators.

- The Power button turns the QL 320 on and off.
- The Feed button advances a length of media which is determined by the type of media being used. Label media will be advanced to the next gap or bar sense marker. Journal (plain) media will be advanced a length determined by the printer's software.
- The Function button is controlled by a printer's specific application to support such functions as:
 - Print a battery Level reporting
 - Print the Local Area Network (LAN) status
 - Print a Short Range Radio Frequency (SRRF) status
 - Print a Media supply report

The green LED on the left side of the control panel indicates the status of several printer features:

- A slowly blinking sequence indicates the printer's battery needs charging.
- Printers with a wireless QuickLink module installed: a quickly blinking sequence indicates the printer has not established a link to either a Local Area Network or a compatible wireless equipped terminal.
- Printers with a wireless QuickLink module installed: A steadily lit indicator shows that the printer has established a wireless link, either to the LAN or to a compatible terminal.
A steadily lit green indicator on a non-wireless printer is a power-on indicator.

The yellow LED on the right side of the control panel has two indication conditions.

- A rapidly blinking yellow LED and a chime indicate that no application has been loaded into the printer.
- Printers with a wireless QuickLink module installed: a rap-

idly blinking LED indicates normal data transmission.

- A steadily lit yellow LED indicates an error condition. This can be caused by one of the following:
 1. The media cover is not completely closed and latched.
 2. The printer is out of media.

Green LED

Steady Light indicates power on and/or established RF link.

Fast Blink indicates no RF link (on RF equipped units only)

Slow Blink means low battery

Power Button

Press to turn unit on. Press again to turn unit off

Yellow LED

Steady Light indicates error condition: out of media or media cover not closed.

Fast Blink indicates RF activity (on RF equipped units only)

Fast blink with beeper indicates no application loaded

Feed Button

Press to advance the media one blank label or a software determined length of journal media.

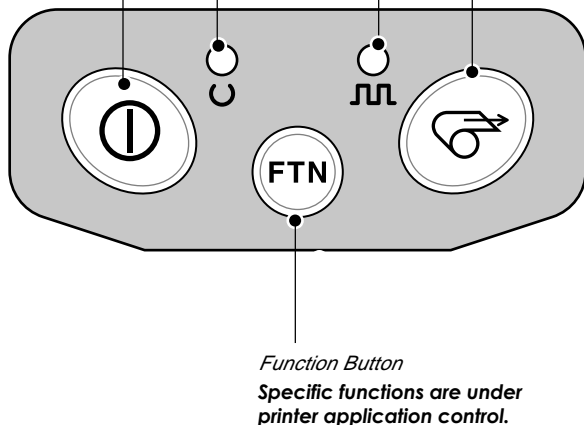

FIGURE 8: STANDARD CONTROL PANEL

LCD Control Panel

The optional LCD control panel has buttons for the power on/off and media feed functions just as in the standard control panel. In addition, it has two keys which allow easy navigation and selection of menu options affecting many printer functions.

The “Scroll” button allows scrolling through the various options and settings. The “Select” button allows selection of the option or function displayed on the screen.

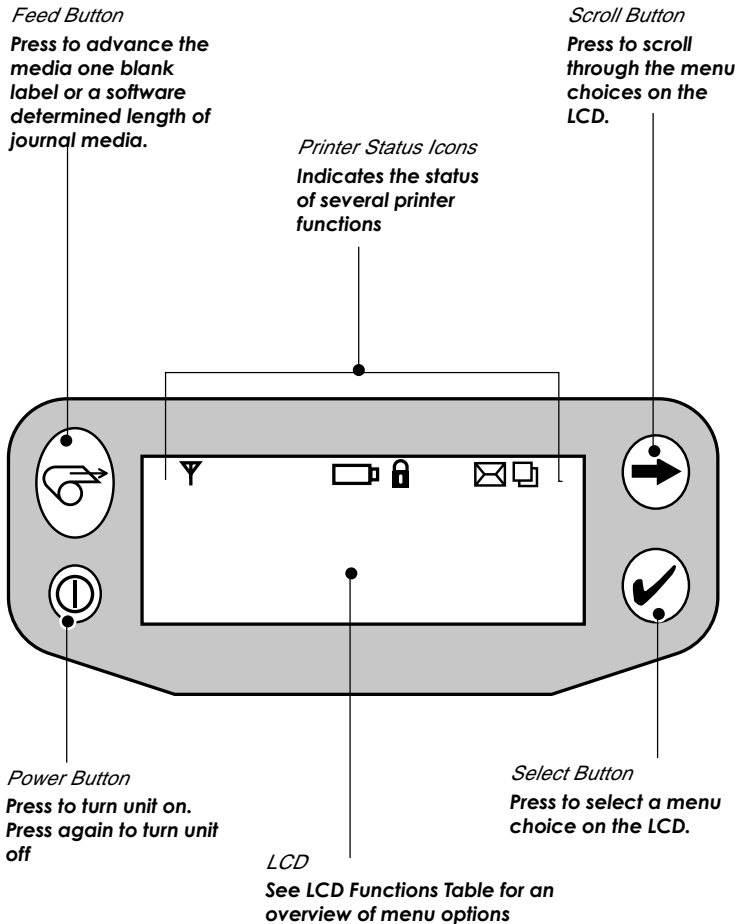





FIGURE 9: OPTIONAL LCD CONTROL PANEL

The top of the screen has a row of status icons which indicate the state of various printer functions:

 Indicates that the printer is associated with a wireless Local Area Network (LAN). This icon is functional only with QL 320N network printers.

 A flashing icon indicates low battery status. You should suspend any printing operations and recharge or replace the Battery Pack as soon as is convenient.

 A flashing icon indicates that the media cover is open or not properly latched.

 A flashing icon indicates that a file is being downloaded to the printer.

 A flashing icon indicates that the printer does not detect any media. This could indicate an out of media condition, or improperly loaded media.

In addition to the status icons, the LCD control panel can display many of the printer's settings and functions as text. Applications can be written to allow the user to view and /or modify these settings using the scroll and select keys on the display. Refer to the "LCD Functions Table" on the following page for the full set of printer features that can be made available with the LCD panel.

The LCD has a backlighting option which allows viewing of the screen in a dark environment, or provides better contrast in a very bright environment. Use of the display backlight will decrease the time the printer will run between charges.

LCD Functions

Function	Default setting	Scroll & Select Options
Sensor Type	Gap	<ul style="list-style-type: none"> • Bar • Gap
Print Width	Factory Set Value	<ul style="list-style-type: none"> • Increase (+120 dots max.) • Decrease (-120 dots max.)
Baud Rate	19200	<ul style="list-style-type: none"> • 9600 • 19200 • 32400
Data Bits	8	<ul style="list-style-type: none"> • 7 • 8
WLAN ID*	Factory Set Value	N/A
Label Top	000	<ul style="list-style-type: none"> • Increase (+120 dots max.) • Decrease (-120 dots max.)
Left Position	000	<ul style="list-style-type: none"> • Increase (+120 dots max.) • Decrease (-120 dots max.)
LCD Contrast	0	<ul style="list-style-type: none"> • Increase • Decrease
No-activity Timeout	60 sec.	<ul style="list-style-type: none"> • 60 sec. • 5 min. • 10 min. • 30 min • Custom*
Print Darkness (Head Temperature)	00	<ul style="list-style-type: none"> • Increase (+10 max.) • Decrease (-10 max.)
Tear-off Position	00	<ul style="list-style-type: none"> • Increase (+120 dots max.) • Decrease (-120 dots max.)
Media Type	Label	<ul style="list-style-type: none"> • Label • Journal
LCD Backlight	Off	<ul style="list-style-type: none"> • On • Off • Momentary On w/ time delay
Factory Reset (Resets all to factory set values)	No	<ul style="list-style-type: none"> • No • Yes

* Some parameters, such as the WLAN ID number and non-standard no-activity time out values can be set using a PC running Zebra's Label Vista label creation program and a data cable link to the printer.

Verify the Printer Is Working

Before you connect the printer to your computer or portable data terminal, make sure that the printer is in proper working order. You can do this by printing a configuration label using the “two key reset” method. If you can’t get this label to print, refer to “Troubleshooting”.

Printing a Configuration Label

1. Turn the printer off. Load the media compartment with journal media (media with no black bars printed on the back)
2. Press and hold the Feed Button.
3. Press and release the Power button and keep the Feed button pressed. When printing starts, release the Feed button.

The unit will print a line of interlocking “x” characters to insure all elements of the print head are working, print out the version of software loaded in the printer and then print two reports.

The first report indicates model, ROM version, serial number, baud rate, etc. The second report prints out more detailed information on the printer’s configuration and parameter settings. If no second report appears, there is no application loaded. (See the Troubleshooting Section for a sample print-out and a further discussion on how to use the configuration label as a diagnostic tool.)

Connecting the Printer

The printer must establish communications with a host terminal which sends the data to be printed. Communications occur in four basic ways:

- By a cable between the printer and its host terminal
- Linking to a host terminal via Infrared (usually by means of the industry standard IrDA protocol)
- By means of a Short Range Radio Frequency (SRRF) link.
- By means of a wireless LAN (Local Area Network). This applies to QL 320N Network Printers only.

Cable Communications

⚠ CAUTION. The power should be turned off before connecting or disconnecting the communications cable.

All QL 320 printers can communicate by cable; the specific cable supplied with your printer will vary with the host terminal. The 8-pin circular connector on your communications cable plugs into the serial communications port on the side of the QL 320 printer. It is keyed to assure correct alignment; do not try to force it if it does not plug in. The other end of the cable must be plugged into the host terminal as shown in Figure 10, or to a serial port on a computer (Figure 11.) Communications between the terminal and the printer are controlled by the applications running on the terminal and the printer.

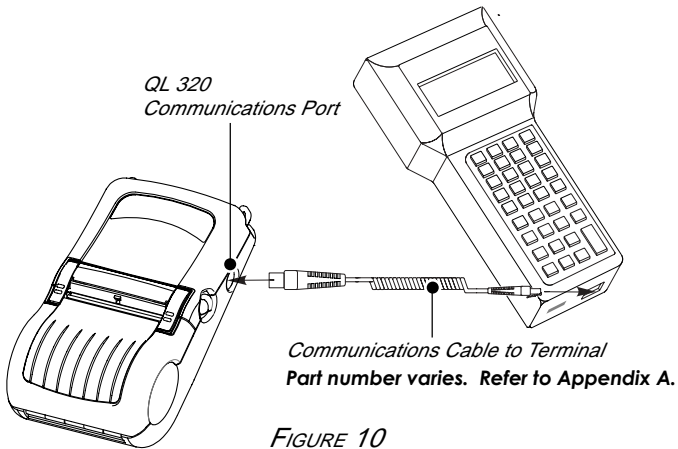

FIGURE 10

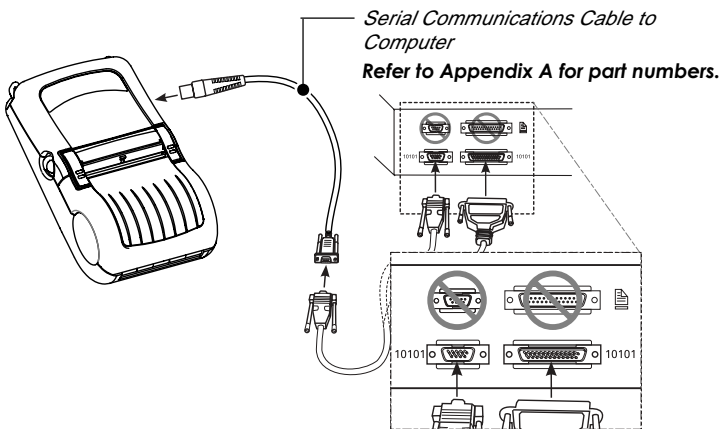

FIGURE 11

IR Communications

Printers equipped for infrared (IR) communications are identified by a small "IR" logo on the unit's label. IR allows wireless communications between the printer and the host terminal. IR units can also communicate with a cable as detailed above, however, IR functions are disabled when the cable is plugged in. QL 320 units with the IR option can be configured to conform to the standard IrDA communications protocol

Linking a Printer to an IrDA Host

IrDA compliant terminals will automatically initiate communications to the printer. First insure that there is a direct line of sight between the printer and the terminal that will be sending data. The IR window on the front of the QL 320 must face the corresponding window on the terminal to properly send and receive signals. An IrDA compliant terminal will seek out any linkable devices and establish communications between them, even turning the printer on if necessary.

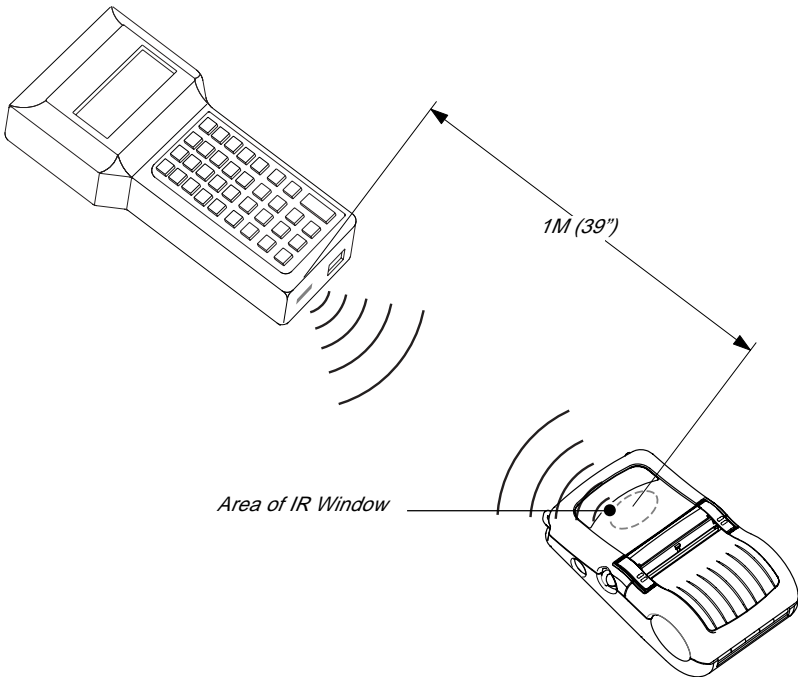

FIGURE 12

SRRF Communications

Both the printer and the device it communicates with must follow either the Bluetooth standard or Zebra's proprietary SRRF protocol. The communications protocol is determined by the specific QuickLink module installed in the printer.

Printers equipped for short range radio frequency communications (SRRF) allow wireless communication with their host terminals from any direction. Reliable transmission distances will vary but usually exceed 1m. (39") under worst conditions. SRRF printers can be identified by reading the printer's model number label on the front of the unit, which will show the radio module's identification number and/or its operating frequency. QL 320 printers equipped with a Bluetooth wireless module will have the Bluetooth logo on the model number label.

Zebra SRRF Network Overview

Zebra's short range RF network operates as a collection of linked pairs of terminals and printers. There is no base station or centralized control; control of the network is distributed across the entire network.

Before SRRF operation can begin, the QL 320 must be "linked" to a terminal with a compatible short-range radio. Linking means that addresses are exchanged between the terminal and the printer. Once linked, the terminal and the printer become a "linked pair" and communicate exclusively with each other. The terminal and the printer can be turned on and off without affecting the link; it remains valid until another link is deliberately created. Thus it is not necessary to perform a link every time that the equipment is used. So long as the linked pair is kept together, they remain linked indefinitely. If the linked pair is not stored together, then the terminal and printer selected should be linked prior to use.

Multiple linked pairs can be operated in close quarters and each terminal will only communicate with its linked printer. Each SRRF radio module has a unique device address (terminal or printer), based on the device serial number.

Linking From the Terminal to the Printer

The linking operation can be activated from either the terminal or the printer. If the terminal has a scanner available, then the bar-coded serial number on the back of every printer can be scanned and used to establish the printer's unique address. Once the printer's address is established, the terminal can then initiate a link to that printer. If no scanner is available the user

can manually enter the serial number of the printer; however, this method is not recommended. The terminal can only capture the desired printer using this type of link.

The terminal must be programmed to guide the user through scanning the printer serial number bar-code, then execute an algorithm which converts the serial number into an address. Zebra can provide C source code to licensed OEM customers that handles the conversion from serial number to address.

Linking From the Printer to the Terminal

When no scanner is available, and/or no additional software is to be written for the terminal, then the linking operation can be initiated solely by the printer.

In this procedure the printer broadcasts a message seeking an available terminal. If a terminal “hears” the broadcast and is available, it will respond by linking to the printer.

To insure a secure link, the user must perform the link operation far enough away from other operating terminals so that the printer does not inadvertently capture some other user’s terminal. Any other terminal that hears the broadcast message from the printer may try to link to it, therefore you should insure that only one terminal is within broadcast range. Feedback is available from the printer as to the outcome of the link operation.

Bluetooth™ Networking Overview

The following section only applies when the Bluetooth Module (FCC ID: I28MD-BTC2-E) is installed in the QL320 printer (note that only one of the radio options can be installed in the printer at one time).



Exposure to Radio Frequency Radiation

The radiated output power of this internal wireless radio is far below the FCC radio frequency exposure limits. Nevertheless, this Bluetooth radio must be used in such a manner that the antenna is 2.5 cm or further from the human body.

The radio and antenna are mounted internally in this printer in such a way that, when the printer is used in a standard configuration (belt clip, soft case, shoulder strap), the 2.5 cm distance from the users body will be met. Do not use the printer in an unauthorized manner.

The internal wireless radio operates within guidelines found in radio frequency safety standards and recommendations. The level of energy emitted is far less

than the electromagnetic energy emitted by wireless devices such as mobile phones.

“Bluetooth” is a worldwide standard for the exchange of data between two devices via radio frequencies. Bluetooth radios are relatively low powered to help prevent interference with other devices running at similar radio frequencies. This limits the range of a Bluetooth device to about 10 meters (about 32 feet).

In order to exchange data, two Bluetooth enabled devices must establish a connection. Bluetooth software is always running in the background, ready to respond to connection requests. One device (known as the *master* or the *client*) must request a connection with another. The second device (the *slave* or the *server*) then accepts or rejects the connection. A Bluetooth enabled QL 320 will normally act as a slave, but in theory any Bluetooth device can be either a master or a slave. This miniature network is sometimes referred to as a “piconet” and can consist of several Bluetooth enabled devices.

Each Bluetooth QL 320 has a unique Bluetooth Device Address (BDA) loaded into its Quick Link module when manufactured.

A Typical Bluetooth Connection Sequence

In this simplified sequence “Joe’s Terminal” is a Bluetooth ready hand held terminal running an application that needs access to a printer.

1. Joe’s Terminal performs a search of its “piconet” (a Device Inquiry) and determines that there are four Bluetooth devices in the vicinity.

2. Joe’s Terminal queries each of the four nearby devices to determine which services they provide (a Service Discovery). The Bluetooth enabled QL 320 “Sandy’s Printer” offers the printing service.

3. Joe’s Terminal sends a print connection request to Sandy’s Printer.

4. Sandy’s Printer evaluates the request and determines that Joe’s Terminal is permitted to use the print service, *but only if the correct password is submitted.*

5. Sandy’s Printer queries Joe’s Terminal for the password (Authentication).

6. Joe’s Terminal returns the correct password and the print connection is established.

7. After Joe’s Terminal is finished printing it disconnects with

Sandy's Printer. (Some Bluetooth services disconnect automatically, others must be closed manually.)

There are several layers of security in the Bluetooth system, so this sequence may not be a completely accurate representation of how your printer may function in a Bluetooth environment. For the most part, communications using the Bluetooth protocol are initiated and processed without any operator intervention, much like the IrDA system described previously.

Wireless Local Area Network (WLAN) Module Using CF Radio

The following section only applies when the CF (Compact Flash) WLAN module (Contains FCC ID: H9PLA4137) is installed in the QL320 printer (note that only one of the radio options can be installed in the printer at one time). The FCC ID number label is on the front of the module and can be read with the module installed.



WARNING: Use of the QL320 with the radio module marked "Contains FCC ID: H9PLA4137 meets the FCC requirements for radio frequency (RF) radiation exposure in the standard body worn configuration with no minimum separation. In this configuration, which applies whether the belt clip or shoulder strap is used, the face of the printer from which paper is transported is facing away from the user's body. The standard configuration must always be used when the printer is body worn.

The printer with this radio option has been SAR tested. The maximum SAR value measured was 0.26 W/kg averaged over 1 gram.

Printers equipped for Wireless Local Area Network (WLAN) communications using the industry standard 802.11 or 802.11b protocols are known as QL 320N Printers. These printers allow wireless communication as a node within a local area network, and its wireless capabilities allow communications from any point within the LAN's perimeter. Methods of establishing communications to the QL 320 will vary with each LAN application.

QL 320N printers can be identified by the model number on the front of the unit.

Wireless Local Area Network (WLAN) Module Using PCMCIA Radio

The following section only applies when the PCMCIA WLAN module (FCC ID: I28-QL320352) is installed in the QL320 printer (note that only one of the radio options can be installed in the printer at one time). The FCC ID number label is on the front of the module and can be read with the module installed.



WARNING: Use of the QL320 with the radio module marked with FCC ID: I28-QL320352 meets the FCC requirements for radio frequency (RF) radiation exposure in the standard body worn configuration with no minimum separation. In this configuration, which applies whether the belt clip or shoulder strap is used, the face of the printer from which paper is transported is facing away from the user's body. The standard configuration must always be used when the printer is body worn. This configuration maintains the required 1cm separation distance.

The printer with this radio option has been SAR tested. The maximum SAR value measured was .819 W/kg averaged over 1 gram.

Printers equipped for Wireless Local Area Network (WLAN) communications using the industry standard 802.11 or 802.11b protocols are known as QL 320N Printers. These printers allow wireless communication as a node within a local area network, and its wireless capabilities allow communications from any point within the LAN's perimeter. Methods of establishing communications to the QL 320 will vary with each LAN application.

QL 320N printers can be identified by the model number on the front of the unit.

Setting Up the Software

The QL 320 uses Zebra's CPL Programming language which was designed for mobile printing applications. CPL is fully described in the Mobile Printing Systems Programming Manual, which is available in Portable Document Format (.pdf) on-line at Zebra's website.

You can also use Label Vista™, Zebra's Windows™ based label creation program which uses a graphical interface to create and edit labels in the CPL language. Label Vista is available either on-line at Zebra's website, or on a CD (part number AC15065-1).

The QL 320 with its optional memory upgrade can support an interpreter for ZPL II®, the programming language used by Zebra desktop printers. To use ZPL II, refer to the ZPL II Programming Guide. If you choose to use a third party label preparation system, follow the installation instructions included in the package.

Adjustable Shoulder Strap

Refer to Figure 14, below.

Snap each end of the shoulder strap into the “D” rings in the top of the printer. Slide the buckle away from or towards the printer until you achieve the desired length.

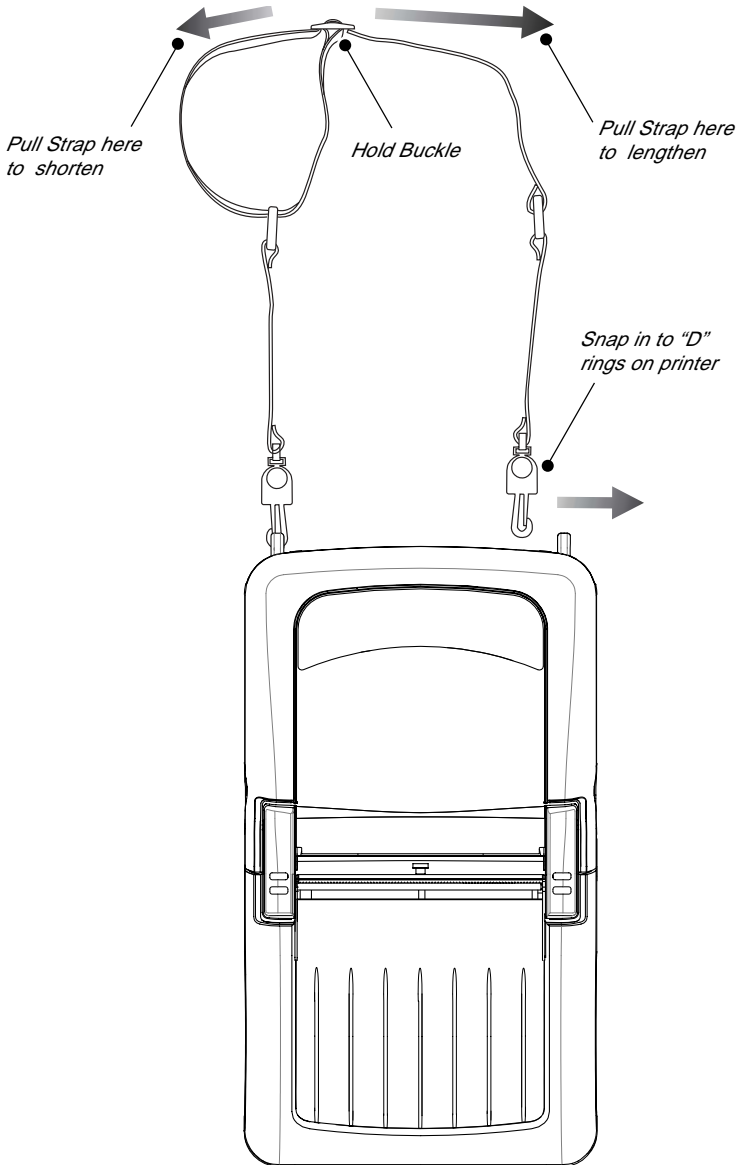

FIGURE 14

Belt Clip

If the QL 320 is equipped with a belt clip, hook the clip over your belt, and ensure that the clip is securely attached to the belt. The belt clip will pivot to allow you to move freely while wearing the printer.

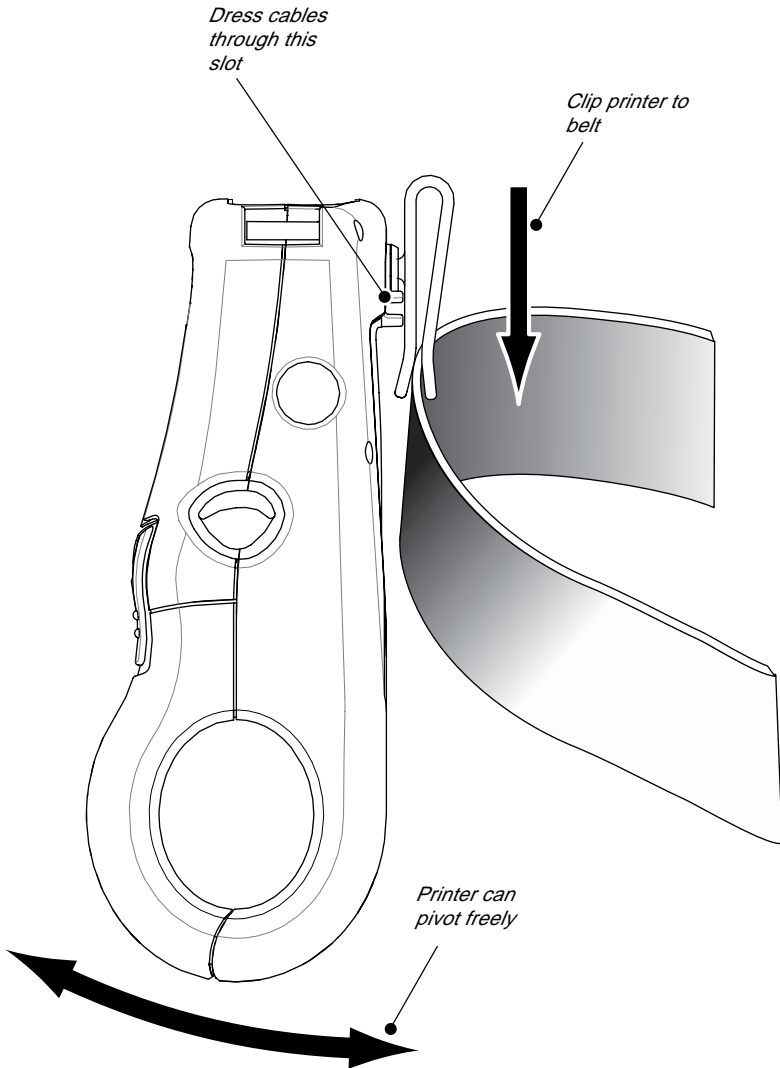



FIGURE 15

Preventive Maintenance

 **WARNING:** *To avoid possible personal injury or damage to the printer, never insert any pointed or sharp objects into the printer.*

Extending Battery Life

- Never expose the battery to direct sunlight or temperatures over 104° F (40° C).
- Always use a Zebra charger designed specifically for Lithium-Ion batteries. Use of any other kind of charger may damage the battery.
- Choose the media that is easiest to “burn.” An authorized Zebra re-seller can help you determine the optimum media for your application.
- If you print the same text or graphic on every label, consider using a pre-printed label.
- Choose the correct print darkness, and print speed for your media.
- Use software handshaking (XON/XOFF) whenever possible.
- Select Tear-Off mode whenever possible (Peel-Off mode uses more power).
- If your printer has the optional LCD display: Use the display backlight only when necessary. Turn it off whenever it is not needed. The LCD backlight consumes a great deal of power.
- Pull the battery out of the printer if the printer won't be used for a day or more and you're not performing a maintenance charge.
- Consider purchasing an extra battery.
- Remember that any rechargeable battery will lose its ability to maintain a charge over time. It can only be recharged a finite number of times before it must be replaced.

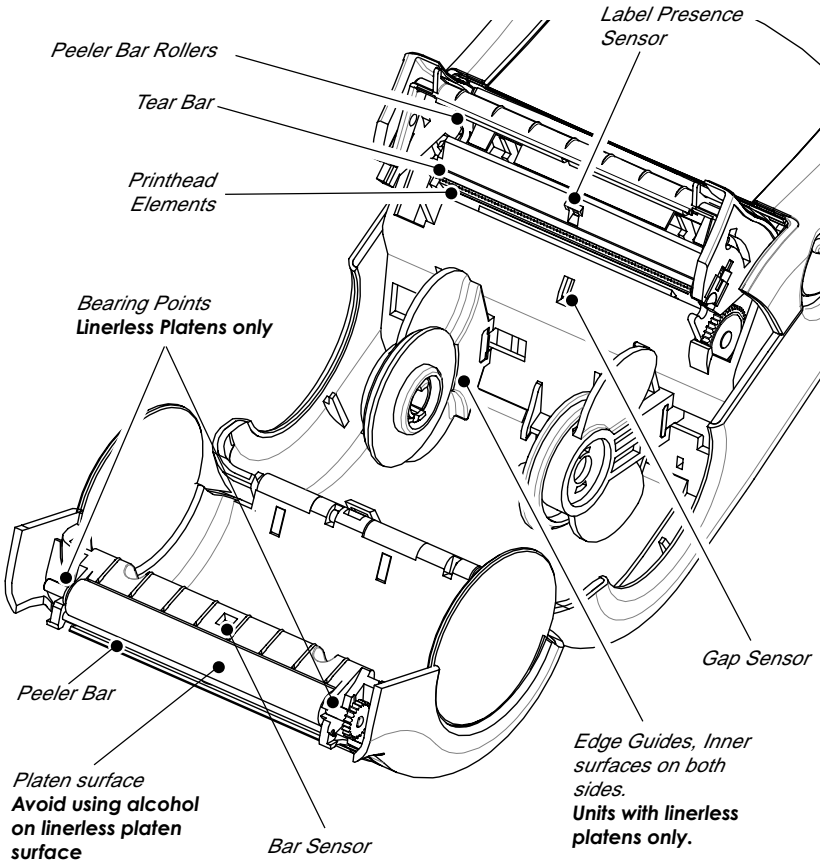

FIGURE 16

Cleaning



CAUTION.- Use only the cleaning agents indicated. Zebra Technologies Corporation will not be responsible for damage caused by any other cleaning materials used on this printer.

Never use any sharp objects on the printer mechanism as they could damage the print head and platen. Clean the printer with either the cleaning pen supplied with the printer or a cotton swab saturated with alcohol.

Area	Method	Interval
Printhead (Figure 16)	Use the supplied cleaning pen or 70% isopropyl alcohol on a cotton swab to clean the print elements from end to end (the print elements are located in the thin gray line on the printhead). <i>If print quality has not improved after performing this procedure, try cleaning the printhead with a Cleaning Pad. This specially prepared material removes contamination buildup without damaging the printhead. Refer to Appendix C for more information.</i>	After every five rolls of media (or more often, if needed) Linerless media requires more frequent cleaning.
Platen Roller (Figure 16)	Rotate the platen roller and clean it thoroughly with the cleaning pen or 70% isopropyl alcohol and a cotton swab. Units with linerless platens: Rotate platen & clean bearing points only. <i>Avoid use of alcohol on the surface of linerless platens!</i>	
Peel bar (Figure 16)	Clean thoroughly with the cleaning pen or 70% isopropyl alcohol and a cotton swab.	As needed
Tear bar (Figure 16)	Clean thoroughly with the cleaning pen or 70% isopropyl alcohol and a cotton swab.	
Exterior	Water-dampened cloth	
Interior (Figure 16)	Brush/air blow. Insure the Bar Sensor, Gap Sensor and Label Present Sensor windows are free of dust.	After every five rolls of media (or more often, if needed)
	Units with linerless platens: Clean inside surfaces of edge guides and media support rollers with the supplied cleaning pen or 70% isopropyl alcohol on a cotton swab.	

Troubleshooting





Standard Control Panel

If the printer is not functioning properly, refer to the chart below to find the state of the two LEDs on the Control Panel. Then refer to the Troubleshooting topic referenced in the chart to resolve the problem.

Green LED	Yellow LED	Indication	Ref. to Topic
Steady	Off	Normal Operation, and/or RF Link established	n/a
Off	Off	Power Off	1
Fast Blink	Off	No RF Link	6, 11
Slow Blink	Off	Low Battery	3, 6, 7
Steady	Steady	Out of media, or Media Cover not closed	9, 11
Steady	Fast Blink	Normal RF activity	8
Steady	Fast Blink, Beeper Sounds	No application	8

Optional LCD Control Panel

The top of the display shows several icons which indicate various printer functions. Check the indicator status, then refer to the Troubleshooting topic referenced in the chart to resolve the problem.

Status Icon	Condition	Indication	Ref. to Topic
	Steady	RF Link established	n/a
	Off	No RF Link	6
	Flashing	Low Battery	3, 6, 7
	Flashing	Head latch not closed	9, 11
	Flashing	Printer is receiving a file	8
	Flashing	Out of media,	9, 11
Blank Screen	n/a	No application	1,13

Troubleshooting Topics

1. No power

- Check that battery is installed properly
- Recharge or replace battery as necessary.

2. Media does not feed:

- Be sure print head is closed and latched.
- Check spindle holding media for any binding.
- If unit is equipped with label presence sensor: Insure most recently printed label is removed. Also insure label sensor is not blocked.

3. Poor or faded print or flashing:

- Clean print head.
- Check battery and recharge or replace as necessary
- Check quality of media.

4. Partial/missing print:

- Check media alignment
- Clean print head.
- Insure printhead is properly closed and latched.

5. Garbled print:

- Check baud rate.

6. No print:

- Check baud rate
- Replace battery
- Check cable to terminal
- Establish RF Link (Wireless units only) or restore LAN associativity (QL 320N models only)
- Invalid label format or command structure — put printer in Communications Diagnostic (Hex Dump) Mode to diagnose problem.

7. Reduced battery life

- Check battery date code — if battery is one to two years old, short life may be due to normal aging.
- Recondition battery.
- Replace battery.

8. Yellow error light or flashing:

- No application or application corrupted: reload program.
- If using wireless communications: flashing indicator is normal while data is being transmitted or received.

continued on next page

9. Yellow error light always on,  or  flashing:

- Check media is loaded and print head is closed and securely latched.

10. Skips labels:

- Check media for top of form sense mark or label gap.
- Check that the maximum print field has not been exceeded on label.
- Insure bar/ or gap sensor is not blocked or malfunctioning

11. Communication Error:

- Check media is loaded, head is closed and error light is off.
- Check baud rate.
- Replace cable to terminal.

12. Label Jam:

- Open head release latch and media cover.
- Generously apply alcohol to printer in area of jammed label.

13. Blank LCD Screen (only for units with optional LCD control panel)

- No application loaded or application corrupted: reload program.

Troubleshooting Tests

Printing a Configuration Label

To print out a listing of the printer's current configuration follow these steps:

1. Turn the printer off. Load the media compartment with journal media (media with no black bars printed on the back)
2. Press and hold the Feed Button.
3. Press and release the Power button and keep the Feed button pressed. When printing starts, release the Feed button.

Sample Configuration Label

Zebra QL 320 V79/00 12/06/01
CHK: FFFF XXQT01-12-0001
HTQ37923 /18
Testing Memory...
Memory tested and OK
Baud Rate: 19200 BPS
In-activity Timeout: 120 Secs
Low battery Shut-down: 168

End of report.

XXQT01-12-0001

Program:
Firmware: HTQ37923 /18
Chksum: SE9F
Software: HTTST00a
Chksum: 7068
Ver: L4.R79.23.U998.B19.T19.A00

Cable Communications:
19200 BPS, N,8,1
Handshake: Xon-Xoff/hardware
DSR: 0

Wireless Communications:
Bluetooth:
version 1.1.0
.date 03/20/02
.baud 57600
.device printer
.mode slave
.local_name ?
.authentication off
.discoverable on
.encryption off
.address 00:80:37:16:85:6A

00803716856A

Print Head Test

End of First Report

Unit Serial Number

Application Number

Report appears only on units with wireless options installed. Units with no wireless options will print an empty line and resume

This example has a Bluetooth™ module installed. (refer to pages 23-24 for more details.)

FIGURE 17

continued on next page

Sample Configuration Label (continued)

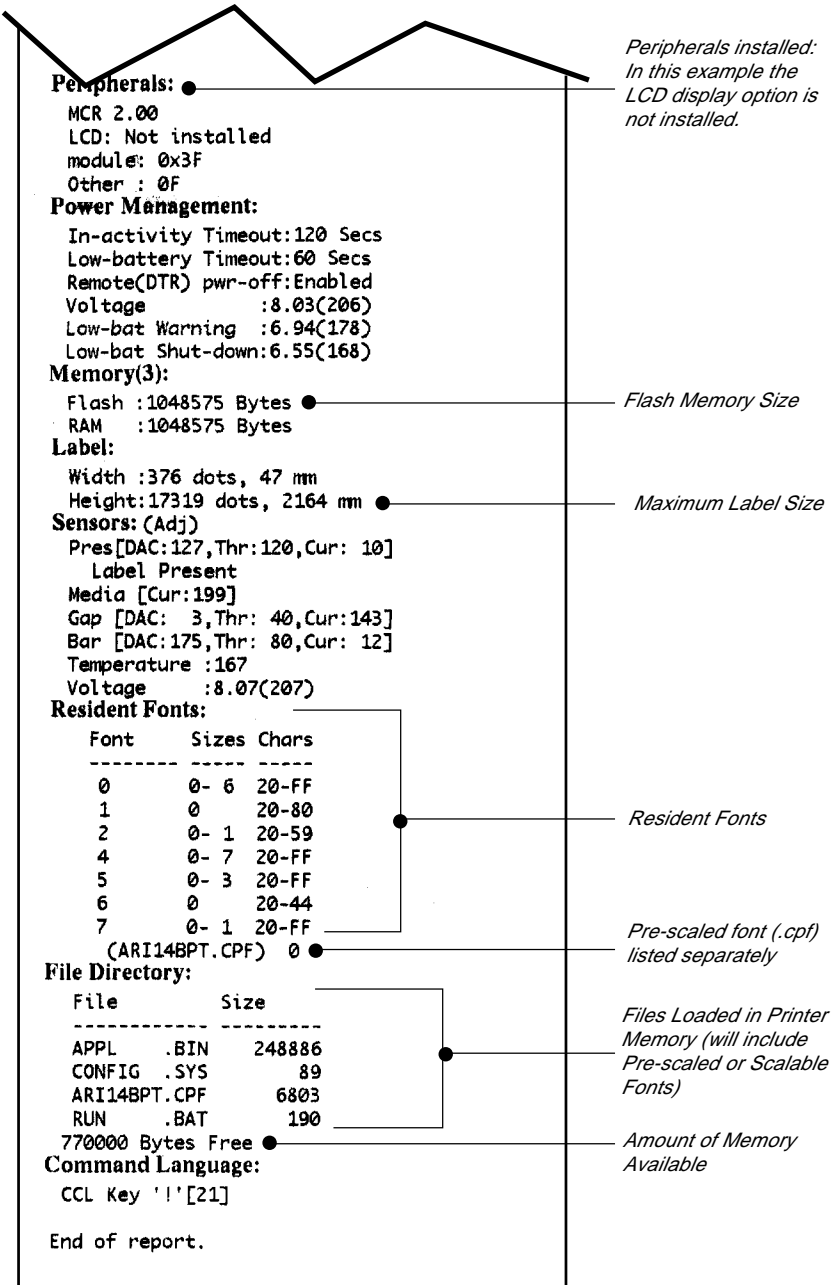

FIGURE 17A

Communications Diagnostics

If there's a problem transferring data between the computer and the printer, try putting the printer in the Communications Diagnostics Mode (also referred to as the "DUMP" mode). The printer will print the ASCII characters and their and their text representation (or the period '.', if not a printable character) for any data received from the host computer

To enter Communications Diagnostics Mode:

1. Print a configuration label as described on pg. 34.
5. At the end of 2nd diagnostics report, the printer will print: "Press FEED key to enter DUMP mode".
6. Press the FEED key. The printer will print: "Entering DUMP mode".

Note: If the FEED key is not pressed within 3 seconds, the printer will print "DUMP mode not entered" and will resume normal operation.

7. At this point, the printer is in DUMP mode and will print the ASCII hex codes of any data sent to it, and their text representation (or "." if not a printable character).

Additionally, a file with a ".dmp" extension containing the ASCII information will be created and stored in the printer's memory. It can be viewed, "cloned" or deleted using the Label Vista application. (Refer the Label Vista documentation for more information.)

To terminate the Communications Diagnostics Mode and return the printer to normal operations:

1. Turn the printer OFF.
2. Wait 5 seconds.
3. Turn the printer ON.

Calling the Help Desk

If the printer fails to print the configuration label, or you encounter problems not covered in the Troubleshooting Guide, contact the Help Desk. Help Desk addresses and phone numbers for your area can be found in Appendix D of this manual. The Help Desk will need the following information:

- Model number/type (e.g. QL 320)
- Unit serial number (Found on the large label on the back of the printer, also found in the configuration label printout. Refer to Figure 17)
- Product Configuration Code (PCC) (15 digit number found on the small label on the back of the unit)

Specifications



NOTE.- Printer specifications are subject to change without notice.

Printing Specifications

Print Density	203 dots/inch (8 dots/mm)
Print Width	Up to 2.9" (71.2 mm)
Print Speed	4" per second (101.6 mm per second)
Print Head Life, calculated	1,964,160" (50 Km) nominal
Distance from Print Element to Top of Form	.571" (14.5 mm) 116 dots

Memory/Communications Specifications

Flash Memory	1 MB flash (standard); 2MB flash (optional)
SRAM Memory	1MB SRAM (standard); 2 MB SRAM (optional)
Standard Communications	RS-232 serial port (8 Pin circular DIN connector) Configurable Baud rate (from 9600 to 57.6 Kbps), parity and data bits. Software (X-ON/X-OFF) or hardware (DTR/STR) communication handshake protocols.
Optional Wireless Communications	Infrared wireless link (meets IrDA 1.1 communications specifications) 2,400 to 115,200 Baud rate Bluetooth compatible 2.4 GHz SRRF link Optional SRRF frequencies of 916 MHz and 2.4 GHz per Zebra proprietary wireless protocol. Optional wireless LAN capabilities comply with 802.11 and 802.11b protocols

Label Specifications

Label/Tag Width	1.5" to 3.1" (38.1 mm to 78.4 mm)
Max. Label/Tag Length	16" (406.4 mm) with standard memory
Inter-label Gap.	.08" to .16" (.12" preferred) 2 mm to 4 mm (3 mm preferred)
Label/Tag Thickness	.0025" to .0065" (.064 mm to .165 mm)
Label Roll Size: Max. Diameter	2.625" (66.7 mm) O.D.
Inner Core Diameter	.75" (19 mm) std, 1.38" (35.05 mm) optional Use Zebra-brand direct thermal media that is outside wound. Media may be reflective (black mark) sensing or transmissive (gap) sensing, die-cut, continuous or linerless. For die-cut labels, use only full auto dies.
Media Requirements	The reflective media black marks should extend past the centerline of the roll. Minimum Black Mark Dimensions: Mark width: 0.5" (12.7mm) perpendicular to the edge of the media, centered within the width of the roll. Mark length: 0.094" (2.4 mm) parallel to the edge of the media.

Font/Bar Code Specifications

Fonts Available	Five resident scalable and rotatable fonts available from 12-48 pt. Downloadable pre-scaled fonts via Label Vista™ software Optional international character sets
1D Bar Codes Available	Codabar UCC/EAN 128 Code 39 Code 93 EAN 8/JAN 8, 2 and 5 digit extensions EAN 13/JAN 13, 2 and 5 digit extensions Interleaved 2 of 5 MSI/Plessey FIM/POSTNET UPC-A, 2 and 5 digit extensions UPC E, 2 and 5 digit extensions
2D Bar Codes Available	MaxiCode PDF 417
Rotation Angles	0°, 90°, 180°, and 270°

Physical/Environmental/Electrical Specifications

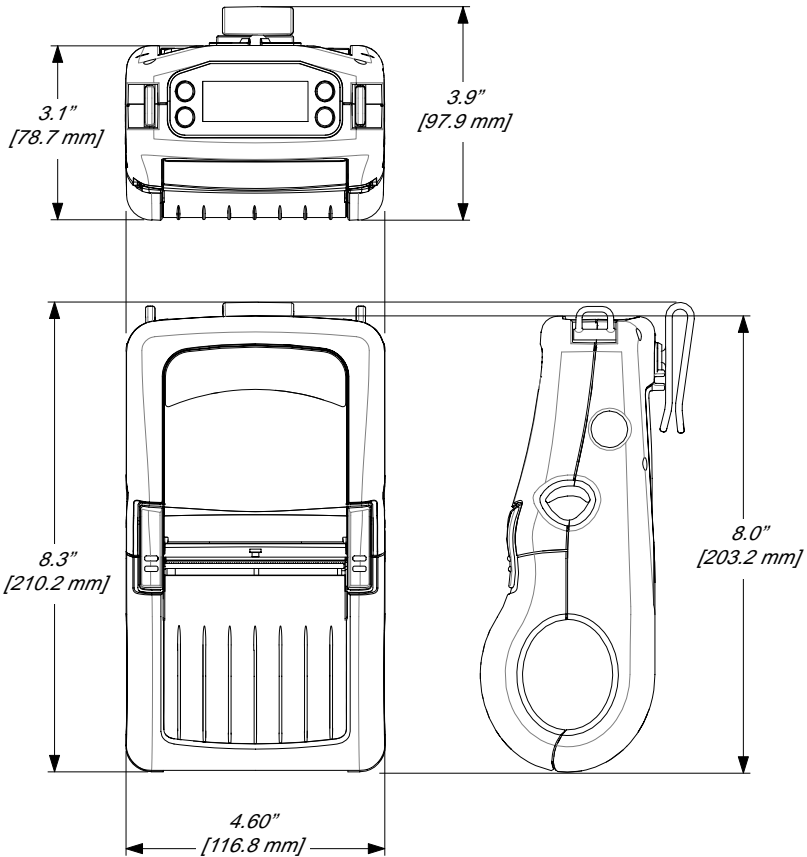

FIGURE 18 OVERALL DIMENSIONS

Weight w/ battery excluding media.	1.65 lbs. (.75 kg.)
Temperature Operating Storage	5° to 122° F (-15° to 50° C) -13° to 158° F (-25° to 70° C) Range
Relative Humidity Operation Storage	10% to 80% (non-condensing) 10% to 90% (non-condensing)
Electrical	Battery: 7.4V Lithium-Ion Charger: External battery charger, 120-230 VAC depending on model selected.

Communications Port

Pin#	Signal Name	Type	Description
1	RXD	input	Receive Data
2	TXD	output	Transmit Data
3	CTS	input	Clear To Send from host
4	RTS	output	Request To Send set high when printer is ready to accept command /data
5	GND		Ground
6	NC		No Connect
7	DSR	input	Data Set Ready low to high transition turns printer on, high to low transition turns printer off (if enabled)
8	DTR	output	Data Terminal Ready set high when printer is on (set to battery voltage for "S" versions)

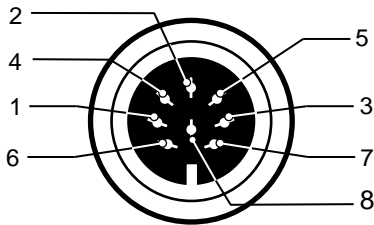

FIGURE 19 COMMUNICATIONS PORT
(8 pin Circular DIN)

Agency Approvals

- FCC Part 15 Subpart B Class A Electromagnetic Radiation Standard
- Built to UL, CUL and TUV standards
- EN50082-1 International Immunity Standard
- EN55022 Class B European Electromagnetic Radiation Standard
- NOM/NYCE (Mexico)
- C-Tick (Australia)

Accessories

- Adjustable shoulder strap
- Protective soft case
- Extra battery packs
- 120-230 VAC battery charger
- Desk Mount
- Data cables

For details, call your authorized Zebra re-seller.

Appendix A

Interface Cables

Part Number 'BL11757-000; 8-Pin DIN to 9-Pin DB PC Cable

This part is also available as a coiled cable under Part Number BL15063-1.

For Use With a Personal Computer

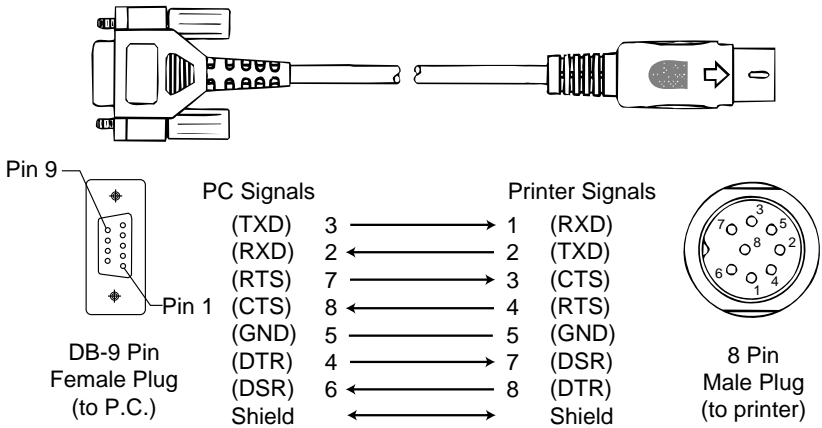

Appendix A

INTERFACE CABLES

Terminal	Cable Part Number	Cord Lgth./Type	Terminal Connector	Printer Connector	Notes	
COMPSEE Apex II	BL12093-3	8' /Coiled	RJ45	8 Pin DIN		
	IXE MX1, MX3 1380, 1390, 1590 2325	6' /Straight	9 Pin DB	8 Pin DIN		
		6' /Straight	9 Pin DB	8 Pin DIN		
		8' /Coiled	RJ45	8 Pin DIN	Power On/Off (+5V)	
NORAND	BL11537-1	8' /Coiled	6 Pin MiniDIN	8 Pin DIN Over-molded		
	BL11537-2	12' /Coiled	6 Pin MiniDIN	8 Pin DIN Over-molded		
	BL12803-1	8' /Coiled	15 Pin D-Sub	8 Pin DIN		
	BL12804-1	8' /Coiled	6 Pin MiniDIN	8 Pin DIN -Locking		
	BL13298-1	8' /Coiled	6 Pin MiniDIN	8 Pin DIN Over-molded	Auto ON/OFF	
	BL13309-1	8' /Coiled	6 Pin Mini DIN	8Pin DIN	Auto ON/OFF	
	6400	6' /Straight	9 Pin DB	8 Pin DIN		
	SYMBOL	BL11391-000	8' /Coiled	DB25 male	8 Pin DIN	
		BL11757-000	6' /Straight	9 Pin DB Fem.	8 Pin DIN	Must be used with Symbol RS232 Adapter - Symbol PN#25-12059-01
		BL12093-1	8' /Coiled	RJ45	8 Pin DIN	a. Power On/Off (+5V) b. Used for the Percon Falcon
BL12093-2		8' /Coiled	RJ45	8 Pin DIN	Power On/Off (DTR Line)	

Appendix A

INTERFACE CABLES (continued)

Terminal	Cable Part Number	Cord Lgth/Type	Terminal Connector	Printer Connector	Notes
SYMBOL (CONT.)					
SPT1700 Series	BL15483-1	9' / Coiled	Cradle	8 Pin DIN	No Power On/Off (DTR Line)
SPT2700 Series	BL15482-1	9' / Coiled	Cradle	8 Pin DIN	Power On/Off (DTR Line)
LRT/LDT3800 Series	CC11371-3	6' / Coiled	PIM Optical	8 Pin DIN	"S" Printers Only
LRT/LDT3800 Series (2 Way)	CC11371-14	6' / Coiled	PIM Optical	8 Pin DIN	"S" Printers Only
LRT/LDT3800 & 6800 Series	CC11371-14	6' / Coiled	PIM Optical	8 Pin DIN	"S" Printers Only
LRT/LDT3800 & 6800 Series	CC11371-15	6' / Coiled	PIM Optical	8 Pin DIN	"S" Printers Only
TEKLOGIC					
7030 ILR	BL13285-2	Coiled	36 Pin IDC Fern	8 Pin DIN	
7025 ILR	BL13285-1	Coiled	15 Pin DB male	8 Pin DIN	
TELXON					
960	BL11122-1	8' / Coiled	RJ45	8 Pin DIN	
960SL Adapter for BL11122-1	CC13711-1	n/a	n/a	n/a	
960 (BL11122-1) & 960SL (CC13711-1)	CP74005	n/a	n/a	n/a	
960	BL12996-1	8' / Coiled	RJ45	8 Pin DIN-Locking	
860 & 912	CL11314-000	8' / Coiled	DB25	8 Pin DIN	

Media Supplies

To insure maximum printer life and consistent print quality and performance for your individual application, it is recommended that only media produced by Zebra be used. These advantages include:

- Consistent quality and reliability of media products.
- Large range of stocked and standard formats.
- In-house custom format design service.
- Large production capacity which services the needs of many large and small media consumers including major retail chains world wide.
- Media products that meet or exceed industry standards.

For more information call Zebra Technologies Corporation at +1.401.739.5800 and ask to speak to a Media Sales Representative.

Appendix C

Maintenance Supplies

In addition to using quality media provided by Zebra, it is recommended that the printer be cleaned as prescribed in the maintenance section. The following items are available for this purpose:

- Cleaning Pen (10 pack), Reorder No. AN11209-1
- Cleaning Kit with Cleaning Pen, and Cotton Swabs, Reorder No. AT702-1

Appendix D

Product Support

When calling with a specific problem regarding your printer, please have the following information on hand:

- Model number/type (e.g. QL 320)
- Unit serial number (Found on the large label on the back of the printer)
- Product Configuration Code (PCC) (15 digit number found on the small label on the back of the unit)

Contact the Help Desk at:

Zebra Technologies Corporation

30 Plan Way

Warwick, Rhode Island 02886-1012 USA

Telephone: +1 401.739.5800

Fax: +1 401.732.7808

e-mail: risupport@zebra.com

In Europe:

Zebra Technologies Europe, Limited

Zebra House

The Valley Centre, Gordon Road

High Wycombe

Buckinghamshire HP13 6EQ, United Kingdom

Telephone: +44 1494 768298

Fax: +44 1494 768210

e-mail: tseurope@zebra.com

Ask for Customer Support

Index

- A
 - Accessories 42
 - Agency Approvals 42
- B
 - Battery, charging 9
 - while printing 9
 - Battery, installing 9
 - Battery life, tips 29
 - Belt clip 28
 - Bluetooth Device Address (BDA). *See* Communications: short range radio frequency (SRRF): Bluetooth™
- C
 - Charger, battery 9
 - Cleaning
 - edge guides 31
 - Exterior 31
 - Interior 31
 - Linerless platen roller 31
 - Peel bar 31
 - Platen roller 31
 - Printhead 31
 - Sensors 31
 - Tear bar 31
 - Communications
 - Connector signals 41
 - infrared (IR) 20
 - SRRF 21
 - Bluetooth™ 22
 - Zebra proprietary protocol 21
 - with a cable 19
 - Communications diagnostics 37
 - Configuration label 34
 - sample printout 35, 36
- D
 - Damage, shipping 7
- H
 - Help Desk, contacting 37
- L
 - Label Vista 17, 26
 - use in troubleshooting 37
- LAN. *See* Wireless communication: Local Area Network
- M
 - Manual
 - CPL Programming 7, 26
 - ZPL II Programming 7, 26
- Media, loading 10
 - adjusting for core diameter 11
 - peel-off mode 12
 - tear-off mode 12
- O
 - Operator Controls 13
 - LCD Keypad 15
 - functions displayed 17
 - Standard Keypad 13
 - error indicator 14
 - power-on indicator 13
- P
 - piconet. *See* Communications: SRRF: Bluetooth™
- Platen
 - linerless 31
- Programming language
 - CPL 7
 - ZPL II 26
 - interpreter for 7
- Q
 - QuickLink™ module 13
- S
 - Shoulder Strap, adjusting 27
 - Software 26
 - Specifications
 - Font/bar Code 39
 - Label 39
 - Memory/communications 38
 - Physical 40
 - printing 38
- T
 - Troubleshooting
 - entering Communications Diagnostics Mode 37
 - entering Communications Diagnostics Mode Diagnosti 37
 - LCD Control Panel 32
 - Standard control panel indicators 32
 - Troubleshooting tests 34
 - printing a configuration label 18
 - Troubleshooting Topics 33
- W
 - Wireless communication
 - Local Area Network 13
 - Local Area Network using CF Radio 24
 - Local Area Network using PCMCIA Radio 25

Patent Information

This product and/or its use may be covered by one or more of the following US patents and corresponding international patents worldwide

D275,286	5,021,641	5,321,246	5,504,322	5,997,193
D347,021	5,029,183	5,335,170	5,528,621	6,004,053
D389,178	5,047,617	5,364,133	5,532,469	6,010,257
D430,199	5,103,461	5,367,151	5,543,610	6,020,906
D433,702	5,113,445	5,372,439	5,545,889	6,034,708
3,964,673	5,140,144	5,373,148	5,552,592	6,036,383
4,019,676	5,132,709	5,378,882	5,570,123	6,057,870
4,044,946	5,142,550	5,396,053	5,578,810	6,068,415
4,360,798	5,149,950	5,396,055	5,589,680	6,070,805
4,369,361	5,157,687	5,399,846	5,612,531	6,095,704
4,387,297	5,168,148	5,408,081	5,642,666	6,109,801
4,460,120	5,168,149	5,410,139	5,657,066	6,123,471
4,496,831	5,180,904	5,410,140	5,768,991	6,147,767
4,593,186	5,229,591	5,412,198	5,790,162	6,151,037
4,607,156	5,230,088	5,415,482	5,791,796	6,201,255B1
4,673,805	5,235,167	5,418,812	5,806,993	6,231,253B1
4,736,095	5,243,655	5,420,411	5,813,343	6,261,009
4,758,717	5,247,162	5,436,440	5,816,718	6,261,013
4,816,660	5,250,791	5,444,231	5,820,279	6,267,521
4,845,350	5,250,792	5,449,891	5,848,848	6,270,072B1
4,896,026	5,262,627	5,449,893	5,860,753	6,285,845B1
4,897,532	5,267,800	5,468,949	5,872,585	6,292,595
4,923,281	5,280,163	5,479,000	5,874,980	6,296,032
4,933,538	5,280,164	5,479,002	5,909,233	6,364,550
4,992,717	5,280,498	5,479,441	5,976,720	6,379,058B1
5,015,833	5,304,786	5,486,057	5,978,004	6,409,401B1
5,017,765	5,304,788	5,503,483	5,995,128	6,411,397B1



Zebra Technologies Corporation

Mobile Printer Center of Excellence

30 Plan Way

Warwick, RI 02886.1012 U.S.A.

Telephone: +1 401.739.5800

+ 1 800.556.7266

Facsimile: +1 401.732.7808

Zebra Technologies Europe Limited

Zebra House

The Valley Centre, Gordon Road

High Wycombe

Buckinghamshire HP13 6EQ, UK

Telephone: +44 (0) 1494 472872

Facsimile: +44 (0) 1494 450103

visit our website at www.zebra.com

