

# ZEBRA TECHNOLOGIES CORP.

## THERMAL CARD PRINTER

Model: P330i



23 April 2008

Report No.: SL08012102-ZBR-007 Rev4.0 (15.225) (P330i)  
(This report supersedes NONE)



Modifications made to the product : None

This Test Report is Issued Under the Authority of:

	
<b>Dan Corona</b> Test Engineer	<b>Leslie Bai</b> Engineering Reviewer

This test report may be reproduced in full only.  
Test result presented in this test report is applicable to the representative sample only.

# EMC Test Report

To: FCC Part 15.225 & IC RSS210

SIEMIC, INC.  
Accessing global markets





**SIEMIC, Inc.**  
Accessing global markets

Title: RF Test Report of Zebra Technologies Corp.  
Model : P330i  
To FCC 15.225 2008, RSS210 Issue 7: 2007

Serial# SL08012102-ZBR-007 Rev4.0 (15.225)(P330i)  
Issue Date 23 April 2008  
Page 2 of 39  
www.siemic.com

**SIEMIC ACREDITATION DETAILS: NVLAP Lab Code: 200729-0**

United States Department of Commerce  
National Institute of Standards and Technology



**Certificate of Accreditation to ISO/IEC 17025:2005**

NVLAP LAB CODE: 200729-0

**SIEMIC Laboratories**  
San Jose, CA

*Is accredited by the National Voluntary Laboratory Accreditation Program for specific services,  
listed on the Scope of Accreditation, for:*

**ELECTROMAGNETIC COMPATIBILITY AND TELECOMMUNICATIONS**

*This laboratory is accredited in accordance with the recognized International Standard ISO/IEC 17025:2005.  
This accreditation demonstrates technical competence for a defined scope and the operation of a laboratory quality  
management system (refer to joint ISO-ILAC-IAF Communique dated 18 June 2005).*

2008-01-01 through 2008-12-31

Effective dates



*Sally A. Bruce*

For the National Institute of Standards and Technology



**SIEMIC, Inc.**  
Accessing global markets

Title: RF Test Report of Zebra Technologies Corp.  
Model : P330i  
To FCC 15.225 2008, RSS210 Issue 7: 2007

Serial# SL08012102-ZBR-007 Rev4.0 (15.225)(P330i)  
Issue Date 23 April 2008  
Page 3 of 39  
www.siemic.com

**SIEMIC ACREDITATION DETAILS: FCC Registration No. 783147**

**FEDERAL COMMUNICATIONS COMMISSION**

Laboratory Division  
7435 Oakland Mills Road  
Columbia, MD 21046

January 27, 2005

Registration Number: 783147

SIEMIC Laboratories  
2206 Ringwood Avenue  
San Jose, CA 95131

Attention: Leslie Bai

Re: Measurement facility located at San Jose  
3 & 10 meter site  
Date of Renewal: January 27, 2005

Dear Sir or Madam:

Your request for renewal of the registration of the subject measurement facility has been received. The information submitted has been placed in your file and the registration has been renewed. The name of your organization will remain on the list of facilities whose measurement data will be accepted in conjunction with applications for Certification under Parts 15 or 18 of the Commission's Rules. Please note that the file must be updated for any changes made to the facility and the registration must be renewed at least every three years.

Measurement facilities that have indicated that they are available to the public to perform measurement services on a fee basis may be found on the FCC website [www.fcc.gov](http://www.fcc.gov) under E-Filing, OET Equipment Authorization Electronic Filing, Test Firms.

Sincerely,  
  
Phyllis Parrish  
Information Technician



**SIEMIC, INC.**  
Accessing global markets

Title: RF Test Report of Zebra Technologies Corp.  
Model : P330i  
To FCC 15.225 2008, RSS210 Issue 7: 2007

Serial# SL08012102-ZBR-007 Rev4.0 (15.225)(P330i)  
Issue Date 23 April 2008  
Page 4 of 39  
www.siemic.com

**SIEMIC ACREDITATION DETAILS: Industry of Canada Registration No. 4842-1**



April 28, 2006

**OUR FILE: 46405-4842**  
**Submission No: 114591**

Siemic Inc.  
2206 Ringwood Ave.,  
San Jose, CA 95131

Dear Sir/Madame:

The Bureau has received your application for the Alternate Test Site and the filing is satisfactory to Industry Canada.

Please reference to the file number (4842-1 ) in the body of all test reports containing measurements performed on the site.

Renewal of the filing is required every two years.

If you have any questions, you may contact the Bureau at the telephone number below or by e-mail at [certification.bureau@ic.gc.ca](mailto:certification.bureau@ic.gc.ca). Please reference our file number ABOVE for all correspondence.

Yours sincerely,

Robert Corey  
Manager Certification  
Certification and Engineering Bureau  
3701 Carling Ave., Building 94  
Ottawa, Ontario  
K2H 8S2  
Tel. No. (613) 990-3869



**SIEMIC, Inc.**  
Accessing global markets

Title: RF Test Report of Zebra Technologies Corp.  
Model : P330i  
To FCC 15.225 2008, RSS210 Issue 7: 2007

Serial# SL08012102-ZBR-007 Rev4.0 (15.225)(P330i)  
Issue Date 23 April 2008  
Page 5 of 39  
www.siemec.com

## SIEMIC ACREDITATION DETAILS: Japan VCCI Registration No. 2195



Voluntary Control Council for Interference  
by Information Technology Equipment  
JF NDA Bldg. 3-3-5, Azabudai,  
Minato-Ku, Tokyo, Japan. 106-0041  
Tel:+81-3-5575-3138  
Fax:+81-3-5575-3137  
<http://www.vcci.or.jp>

February 12 , 2004

**TO: SIEMIC, INC.**

**Membership NO: 2195**

We confirmed your payment for annual membership fee and admission fee. Thank you very much for your remitting.

Please find enclosed VCCI documents. As admission fee and annual membership fee were confirmed, your company registered as VCCI official member.

From now on, it is possible for your company to submit conformity verification report or/and application for registration of measurement facilities.

Please find necessary forms for your submission from VCCI web-site.  
[www.vcci.or.jp](http://www.vcci.or.jp)

When you submit conformity verification report, please submit to Ms. Yoko Inagaki / [inagaki@vcci.or.jp](mailto:inagaki@vcci.or.jp) and application for registration of measurement facilities, please submit to Mr. Masaru Denda / [denda@vcci.or.jp](mailto:denda@vcci.or.jp)

Their address, phone and fax number are absolutely same as L. Please refer address indicated on top right-hand corner of this page.

If you have any other questions regarding membership, feel free to contact me. Thank you very much.

Best Regards,

Naoko Hori (Ms.)  
VCCI  
[hori@vcci.or.jp](mailto:hori@vcci.or.jp)

Enclosure

情報処理装置等電波障害自主規制協議会 (通称VCCI)

T 108-6641 東京都港区麻布台2-3-5 / ア ビルディング (NDAビル) 7階 Tel:03-5575-3138 Fax:03-5575-3137



**SIEMIC ACREDITATION DETAILS: Japan RF Technologies Accreditation No. MRF050927**

**RFT**

# Certificate

This is to certify that the  
Quality Management System  
of

**SIEMIC , Inc.**  
2206 Ringwood Avenue  
San Jose, California 95131 U.S.A

has been authorized to carry out Japan Specified Radio Equipment test by  
order and under supervision of RF Technologies Co., Ltd. according to  
Notification No.88 of Radio Law.

An assessment of the laboratory was conducted according to the "Procedure and  
Conditions for Appointments of 2.4GHz Band Low power data communications system  
that Bluetooth and Wireless LAN test with reference to ISO/IEC 17025  
by an RF Technologies Co., Ltd. auditor.

**Audit Report No. MRF050927**

Kazuyuki Sarashina  
Auditor  
RF Technologies Co., Ltd.

Toshihiro Ikegami  
President  
RF Technologies Co., Ltd.

Audit Date  
September 27th, 2005

Issued Date  
October 5th, 2005

This Certificate is valid until **September 26<sup>th</sup> 2006** or next schedule audit.

No:006 Registered Certification Body  
RF Technologies Co., Ltd.  
472, Nippu-cho, Kohoku-ku, Yokohama, 223-0057, Japan





**SIEMIC ACREDITATION DETAILS: Korea MIC Lab Code: KR0032**

# 시험기관지정서

## Certificate

of Designated Testing Laboratory

지정번호(No.) : KR0032

시험기관명 : (주)현대교정인증기술원  
(Name of Lab.) (Hyundai Calibration & Certification Technologies Co., Ltd)

주 소 : 경기도 이천시 부발읍 아미리 산136-1  
(Address) (137-1, Ami-ri, Bidal-eup, Icheon-si, Kyunggi-Do, Korea)  
2206 Ringwood Avenue San Jose, CA, USA.

시험분야 및 범위 : 유선(Telecommunication Part)  
(Area & Category) 무선(Radio Communication Part)  
전자파장해(EMD) : 미국지사 포함  
전자파내성(EMS) : 미국지사 포함  
전기안전(Safety)  
전자파흡수율(SAR)

위 기관을 정보통신기기시험기관지정및관리등에관한규칙에 의해 정보통신기기시험기관으로 지정합니다.

*This is to certify that the above mentioned laboratory is designated as the testing laboratory in accordance with the Regulations on Designation of Testing Laboratory for Information and Communication Equipment.*

2005년(Year) 7월(Month) 5일(Date)

**전파연구소장**  
Director General of Radio Research Laboratory  
Ministry of Information and Communication  
Republic of Korea





**SIEMIC ACREDITATION DETAILS: Korea CAB ID: US0160**



**UNITED STATES DEPARTMENT OF COMMERCE**  
**National Institute of Standards and Technology**  
Gaithersburg, Maryland 20899

April 17, 2006

Mr. Leslie Bai  
SIEMIC Laboratories  
2206 Ringwood Avenue  
San Jose, CA 95131

Dear Mr. Bai:

I am pleased to inform you that your laboratory has been recognized by the Ministry of Information and Communication's Radio Research Laboratory (RRL) under the Asia Pacific Economic Cooperation (APEC) Mutual Recognition Arrangement (MRA). Your laboratory is now designated to act as a Conformity Assessment Body (CAB) under Appendix B, Phase I Procedures, of the APEC Tel MRA. The pertinent information about your laboratory's designation is as follows:

CAB Name: **SIEMIC Laboratories**  
Identification No.: **US0160**  
Scope:

Coverage	Standards	Date of Recognition
Electro Magnetic Interference	1. RRL Notice No. 2005-82: Technical Requirements for Electromagnetic Interference 2. Annex 8(KN-22), RRL Notice No. 2005-131: Conformity Assessment Procedure for Electromagnetic Interference	April 13, 2006
Electro Magnetic Susceptibility	1. RRL Notice No. 2005-130: Technical Requirements for Electromagnetic Susceptibility 2. Annex 1-7(KN-61000-4-2, -4-3, -4-4, -4-5, -4-6, -4-8, -4-11), RRL Notice No. 2005-132: Conformity Assessment Procedure for Electromagnetic Susceptibility	April 13, 2006

You may submit test data to RRL to verify that the equipment to be imported into Korea satisfies the applicable requirements. The designation of your organization will remain in force as long as its accreditation for the designated scope remains valid and comply with the designation requirements.

The names of all recognized CABs will be posted on the NIST website at <http://ts.nist.gov/mra>. If you have any questions please contact Mr. Jugindar (Joe) Dhillon at (301) 975-5521. We appreciate your continued interest in our international conformity assessment activities.

Sincerely,

David F. Alderman  
Group Leader, Standards Coordination and Conformity Group

cc: Jugindar Dhillon

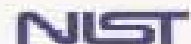





**SIEMIC, Inc.**  
Accessing global markets

Title: RF Test Report of Zebra Technologies Corp.  
Model : P330i  
To FCC 15.225 2008, RSS210 Issue 7: 2007

Serial# SL08012102-ZBR-007 Rev4.0 (15.225)(P330i)  
Issue Date 23 April 2008  
Page 9 of 39  
www.siemec.com

**SIEMIC ACREDITATION DETAILS: Taiwan BSMI Accreditation No. SL2-IN-E-1130R**



**UNITED STATES DEPARTMENT OF COMMERCE**  
National Institute of Standards and Technology  
Gaithersburg, Maryland 20899

May 3, 2006

Mr. Leslie Bai  
SIEMIC Laboratories  
2206 Ringwood Avenue  
San Jose, CA 95131

Dear Mr. Bai:

I am pleased to inform you that your laboratory has been recognized by the Chinese Taipei's Bureau of Standards, Metrology, and Inspection (BSMI) under the Asia Pacific Economic Cooperation (APEC) Mutual Recognition Arrangement (MRA). Your laboratory is now designated to act as a Conformity Assessment Body (CAB) under Appendix B, **Phase I** Procedures, of the APEC Tel MRA. You may submit test data to BSMI to verify that the equipment to be imported into Chinese Taipei satisfies the applicable requirements. The designation of your organization will remain in force as long as its accreditation for the designated scope remains valid and comply with the designation requirements. The pertinent designation information is as follows:

- BSMI number: **SL2-IN-E-1130R** (Must be applied to the test reports)
- U.S. Identification No: **US0160**
- Scope of Designation: **CNS 13438**
- Authorized signatory: **Mr. Leslie Bai**

The names of all recognized CABs will be posted on the NIST website at <http://ts.nist.gov/mra>. If you have any questions, please contact Mr. Dhillon at 301-975-5521. We appreciate your continued interest in our international conformity assessment activities.

Sincerely,

David F. Alderman  
Group Leader, Standards Coordination and Conformity Group

cc: Joginder Dhillon

**NIST**



**SIEMIC, Inc.**  
Accessing global markets

Title: RF Test Report of Zebra Technologies Corp.  
Model : P330i  
To FCC 15.225 2008, RSS210 Issue 7: 2007

Serial# SL08012102-ZBR-007 Rev4.0 (15.225)(P330i)  
Issue Date 23 April 2008  
Page 10 of 39  
www.siemic.com

**SIEMIC ACREDITATION DETAILS: Taiwan NCC CAB ID: US0160**



**UNITED STATES DEPARTMENT OF COMMERCE**  
National Institute of Standards and Technology  
Gaithersburg, Maryland 20899

August 8, 2006

Mr. Leslie Bai  
SIEMIC Laboratories  
2206 Ringwood Avenue  
San Jose, CA 95131

Dear Mr. Bai:

I am pleased to inform you that SIEMIC Laboratories has been recognized by the Chinese Taipei's National Communications Commission (NCC) under the Asia Pacific Economic Cooperation for Telecommunications and Information, Mutual Recognition Arrangement (APEC Tel MRA). Your laboratory is now designated to act as a Conformity Assessment Body (CAB) under Appendix B, Phase I Procedures, of the APEC Tel MRA.

You may submit test data to NCC to verify that the equipment to be imported into Chinese Taipei satisfies their applicable requirements using the following guidelines:

- Your laboratory's assigned 6-digit U.S. identification number is **US0160**. You should reference this number in your correspondence.
- The scope of designation is limited to **LP0002**. Your designation will remain in force as long as your accreditation remains valid for the scope of designation.

If you have any questions please contact Mr. Jogindar Dhillon via email at [dhillon@nist.gov](mailto:dhillon@nist.gov) or via fax at 301-975-5414. The names of all recognized laboratories will be posted on the NIST website at <http://ts.nist.gov/mra>. We appreciate your continued interest in our international conformity assessment activities.

Sincerely,

David F. Alderman  
Group Leader, Standards Coordination and Conformity Group

cc: Jogindar Dhillon

**NIST**



**SIEMIC, Inc.**  
Accessing global markets

Title: RF Test Report of Zebra Technologies Corp.  
Model : P330i  
To FCC 15.225 2008, RSS210 Issue 7: 2007

Serial# SL08012102-ZBR-007 Rev4.0 (15.225)(P330i)  
Issue Date 23 April 2008  
Page 11 of 39  
www.siemic.com

## SIEMIC ACREDITATION DETAILS: Mexico NOM Recognition



CAMARA NACIONAL  
DE LA INDUSTRIA  
ELECTRONICA, DE  
TELECOMUNICACIONES  
E INFORMATICA

### Laboratorio Valentin V. Rivero

México D.F. a 18 de octubre de 2008.

**LESLIE BAI**  
DIRECTOR OF CERTIFICATION  
SIEMIC LABORATORIES, INC.  
ACCESSING GLOBAL MARKETS  
**P R E S E N T E**

En contestación a su escrito de fecha 5 de septiembre del año en curso, le comento que estamos muy interesados en su intención de firmar un Acuerdo de Reconocimiento Mutuo, para lo cual adjunto a este escrito encontrara el Acuerdo en idioma inglés y español preferido de los cuales le pido sea revisado y en su caso corregido, para que si este de acuerdo poder firmarlo para mandarlo con las autoridades Mexicanas para su vista bueno y así poder ejercer dicho acuerdo.

Aprovecho este escrito para mencionarle que nuestro intermediano gestor será la empresa Isabel de México, S. A. de C. V., empresa que ha colaborado durante mucho tiempo con nosotros en lo relacionado a la evaluación de la conformidad y que cuenta con amplia experiencia en la gestión de la certificación de cumplimiento con Normas Oficiales Mexicanas de producto en México.

Me despido de usted enviándole un cordial saludo y esperando sus comentarios al Acuerdo que nos ocupa.

Atentamente:

**Ing. Faustino Gómez González**  
Gerente Técnico del Laboratorio de  
**CANIETI**

Calle 17  
Polanco, Colima  
04100 México, D.F.  
Tel: 5206 0000 con 12 líneas  
Fax: 5204 5349  
www.canieti.org



**SIEMIC ACREDITATION DETAILS: Hong Kong OFTA Recognition No. D23/16V**



Your Ref 來函編號 : D23/16 V  
Our Ref 本局編號 :

Telephone 電話 : (852) 2961 6320  
Fax No 圖文傳真 : (852) 2838 5004  
E-mail 電郵地址 : 20 July 2005

Mr. Leslie Bai  
Director of Certification,  
SIEMIC Laboratories  
2206 Ringwood Avenue  
San Jose, California 95131  
USA

Dear Mr. Bai,

**Application of Recognised Testing Agency (RTA)**

Referring your submission of 28 June 2005 in relation to the application of RTA, I am pleased to inform you that OFTA has appointed SIEMIC Laboratories (SIEMIC) as a Recognised Testing Agency (RTA) :

Please note that, under the Hong Kong Telecommunications Equipment Evaluation and Certification (HKTEC) Scheme, SIEMIC is authorized to conduct evaluation tests on telecommunications equipment against the following HKTA specifications :

Scope of recognition (HKTA Specifications) :

1001, 1002, 1004, 1006, 1007, 1008  
1010, 1015, 1016  
1022, 1026, 1027, 1029  
1030, 1031, 1032, 1033, 1034, 1035, 1039  
1041, 1042, 1043, 1045, 1047, 1048  
2001

You are requested to refer to and comply with the code of practice and guidelines for RTA as given in the Information Note OFTA I 411 "Recognised Testing Agency (RTA) for Conducting Evaluation Test of Telecommunications Equipment", which can be downloaded from OFTA's homepage at <http://www.ofa.gov.hk/tec/information-notes.html>.

If you have any queries, please do not hesitate to contact me.

Yours sincerely,

(K K Sin)  
for Director-General  
of Telecommunications

Office of the Telecommunications Authority  
29/F Wu Chung House 213 Queen's Road East Wan Chai Hong Kong  
電訊管理局  
香港灣仔皇后大道東 213 號胡忠大廈 29 字樓

<http://www.ofa.gov.hk>

This page has been left blank intentionally.

# CONTENTS

1 EXECUTIVE SUMMARY & EUT INFORMATION .....16

2 TECHNICAL DETAILS.....18

3 MODIFICATION .....19

4 TEST SUMMARY .....20

5 MEASUREMENTS, EXAMINATION AND DERIVED RESULTS.....21

ANNEX A. TEST INSTRUMENT & METHOD .....31

ANNEX B EUT AND TEST SETUP PHOTOGRAPHS .....35

ANNEX C. TEST SETUP AND SUPPORTING EQUIPMENT.....35

ANNEX D USER MANUAL, BLOCK & CIRCUIT DIAGRAM.....39

This page has been left blank intentionally.

# 1 Executive Summary & EUT information

The purpose of this test programmed was to demonstrate compliance of the Zebra Technologies Corp., model: P330i against the current Stipulated Standards. The Thermal Card Printer have demonstrated compliance with the FCC 15.225 2008 & IC RSS210 Issue 7: 2007.

Zebra Technologies Corp. is the applicant and claimed manufacturer of this tested product. For the detailed description of this product, please refer to the Thermal Card Printer User Manual.

The equipment under test operating frequency is 13.56 MHz.

The test has demonstrated that this unit complies with stipulated standards.

## EUT Information

**EUT Description**

: The Zebra P330i is a single sided card printer that can print monochrome or full color images on a PVC card in one pass through the printer. The Zebra P330i uses color dye-sublimation ribbons or thermal transfer ribbons to transfer digital images to a PVC card. These cards can be used for identification, loyalty cards, or marketing purposes.

Options for this printer include Ethernet, magnetic card encoding, contact and contact-less smart card encoding, and UHF smart card encoding. Ribbon recognition and security is maintained through RFID technology within the printer. The RFID board and the contactless smartcards use separate transmitters each operating at a frequency of 13.56 MHz in the ISM band.

The RFID system uses an I●CODE1 format and conforms to ISO 15693 specifications. The RFID system is contained on a single PCBA which holds the loop antenna, impedance matching network, RF interface IC and digital controller IC. The design is optimized for short range lower power operation.

The Zebra ZM5e is a RFID reader that can read and encode RFID smart cards. Smart cards carry embedded ultra-thin UHF RFID transponders. Transponders contain thin antennas and integrated circuits that can be read, programmed, and reprogrammed using non-contact radio waves. RFID smart cards allow for non- line of sight reading of the data contained in the IC and feature anti-collision technology, which allows RFID readers to scan and identify several objects simultaneously, such as totes of supplies.

The RFID subsystem is comprised of a ThingMagic Mercury 5e multi protocol UHF RFID reader, a coupler/antenna connected to the reader via a coaxial cable and an adaptor PCB that provides the operating voltage and communications to the RFID reader.

The RFID reader powers and communicates with RFID smart cards via the coupler/antenna. The reader contains a digital processor and analog signal conditioning circuitry. Instructions from the host computer system to encode/read a smart label are sent to the RFID reader via a serial communication link on the adapter PCB. The reader responds to the host with data read and/or a status message. The UHF RF signals generated by the reader are turned on only during a host commanded read or encode operation. The RF signal is an amplitude-modulated frequency-hopping carrier operating between 902MHz and 928MHz. The modulation pattern is governed by the selected UHF RFID protocol. The reader supports EPC Class1 Gen 2/ISO18000-6C UHF RFID protocols.

The coupler/antenna is located in close proximity to the RFID transponder when the smart label is in the rest position prior to printing. The coupler/antenna is a single or dual strip-line transmission line fabricated on a two-sided printed circuit board with one side acting as a ground plane. The coupler/antenna is orientated with the ground-plane side down, roughly parallel to the base of the printer. The reader's transmitter and receiver are both connected directly to the



coupler/antenna via the coaxial cable. Backscatter signals from the transponder are received via the same coupler/antenna as is used to transmit to the transponder.

The adapter PCB provides the correct operating voltage to the RFID reader and serves as a communications interface between host and RFID reader. The adapter PCB down converts the host's voltage, 18 to 30Vdc, to 5.0V nominal at .5 to 1.0 Amp steady state current. The adapter PCB also buffers, both directions, the host and RFID readers RS232 TTL level receive and transmit lines. The adapter PCB provides power and com to the RFID reader through a single discrete cable assembly. The host connects to the adapter PCB via two discrete wire cable assemblies, one for power the other for com.

**Model No** : P330i  
**Serial No** : N/A  
**Input Power** : 100~240 VAC  
**Classification Per Stipulated Test Standard** : RFID Reader



## 2 TECHNICAL DETAILS

Purpose	Compliance testing of Thermal Card Printer with stipulated standard
Applicant / Client	ZEBRA TECHNOLOGIES CORP.
Manufacturer	Zebra Technologies Corp. 333 Corporate Woods Parkway Vernon Hills, IL 60061 USA
Laboratory performing the tests	SIEMIC Laboratories
Test report reference number	SL08012102-ZBR-007 Rev4.0 (15.225) (P330i)
Date EUT received	25 February 2008
Standard applied	47 CFR §15.225: 2008 & RSS 210 Issue 7: 2007
Dates of test (from – to)	28 February 2008 – 03 March 2008
No of Units:	2
Equipment Category:	DXX
Trade Name:	Zebra Technologies Corp.
Model :	P330i
RF Operating Frequency (ies)	13.56 MHz (RFID)
Number of Channels :	1
Modulation :	ASK
FCC ID :	I28-P330I-UHF
IC ID :	3798B-P330IUHF

### 3 MODIFICATION

**NONE**

## 4 TEST SUMMARY

The product was tested in accordance with the following specifications. All testing has been performed according to below product classification:

RFID Reader

**Test Results Summary**

Test Standard		Description	Pass / Fail
47 CFR Part 15.225: 2008	RSS 210 Issue 7: 2007		
15.203		Antenna Requirement	Pass
15.207(a)	RSS Gen(7.2.2)	Conducted Emissions Voltage	Pass
15.225(a)	RSS210(A2.6)	Limit in the band of 13.553 – 13.567 MHz	Pass
15.225(b)	RSS210(A2.6)	Limit in the band of 13.410 – 13.553 MHz and 13.567 – 13.710 MHz	Pass
15.225(c)	RSS210(A2.6)	Limit in the band of 13.110 – 13.410 MHz and 13.710 – 14.010 MHz	Pass
15.225(d)	RSS210(A2.6)	Limit outside the band of 13.110 – 14.010 MHz	Pass
15.225(e)	RSS210(A2.6)	Frequency Stability	Pass
ANSI C63.4: 2003/ RSS-Gen Issue 2: 2007			
PS: All measurement uncertainties are not taken into consideration for all presented test result.			

## 5 MEASUREMENTS, EXAMINATION AND DERIVED RESULTS

### 5.1 Antenna Requirement

**Requirement(s):** 47 CFR §15.203

An intentional radiator shall be designed to ensure that no antenna other than that furnished by the responsible party shall be used with the device.

Antenna requirement must meet at least one of the following:

- a) Antenna must be permanently attached to the device.
  - b) Antenna must use a unique type of connector to attach to the device.
  - c) Device must be professionally installed. Installer shall be responsible for ensuring that the correct antenna is employed with the device.
- 
- 1) The RFID antenna is attached permanently to the device with a gain of -20dBi which meets the requirement.

## 5.2 Conducted Emissions Voltage

Requirement:

Frequency of emission (MHz)	Conducted limit (dBµV)	
	Quasi-peak	Average
0.15–0.5	66 to 56*	56 to 46*
0.5–5	56	46
5–30	60	50

\*Decreases with the logarithm of the frequency.

Procedures:

1. All possible modes of operation were investigated. Only the 6 worst case emissions measured, using the correct CISPR and Average detectors, are reported. All other emissions were relatively insignificant.
  2. A "-ve" margin indicates a PASS as it refers to the margin present below the limit line at the particular frequency.
  3. Conducted Emissions Measurement Uncertainty  
All test measurements carried out are traceable to national standards. The uncertainty of the measurement at a confidence level of approximately 95% (in the case where distributions are normal), with a coverage factor of 2, in the range 9kHz – 30MHz (Average & Quasi-peak) is ±3.5dB.
  4. Environmental Conditions

Temperature	23°C - 25°C
Relative Humidity	50%
Atmospheric Pressure	1019mbar
- Test Date : February 28 & 29 to March 03, 2008  
Tested By :Dan Corona

**Results:**

**Note 1:** Below result is RFID radio.

**Note: 2**

Average Limit
---------------

Quasi-Peak Limit
------------------

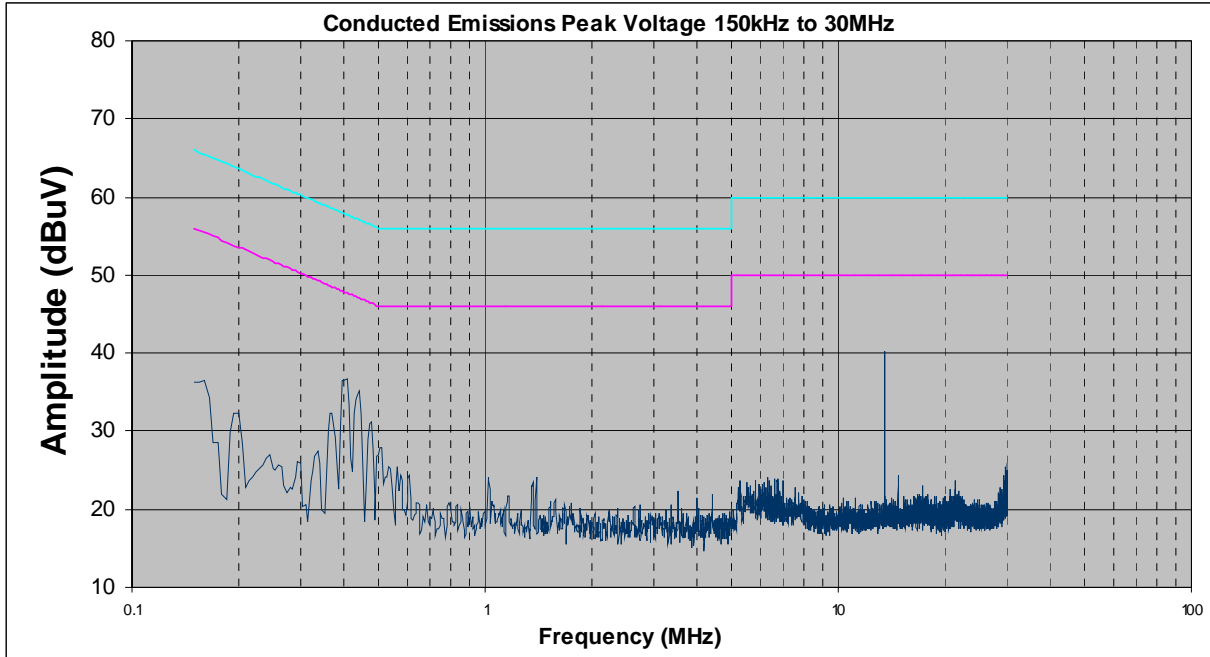

**Phase Line Plot at 120Vac, 60Hz**

Line Under Test	Frequency (MHz)	Corrected Amplitude (dBuV) QP	Limit (dBuV) QP	Margin (dB) QP	Corrected Amplitude (dBuV) AVG	Limit (dBuV) AVG	Margin (dB) AVG
Phase	13.55	40.10	60.00	-19.90	35.80	50.00	-14.20
Phase	0.41	36.70	57.75	-21.05	32.50	47.75	-15.25
Phase	0.44	35.10	57.06	-21.96	31.00	47.06	-16.06
Phase	0.37	32.40	58.50	-26.10	28.40	48.50	-20.10
Phase	0.16	36.50	65.46	-28.96	32.40	55.46	-23.06
Phase	0.20	32.40	63.61	-31.21	28.50	53.61	-25.11

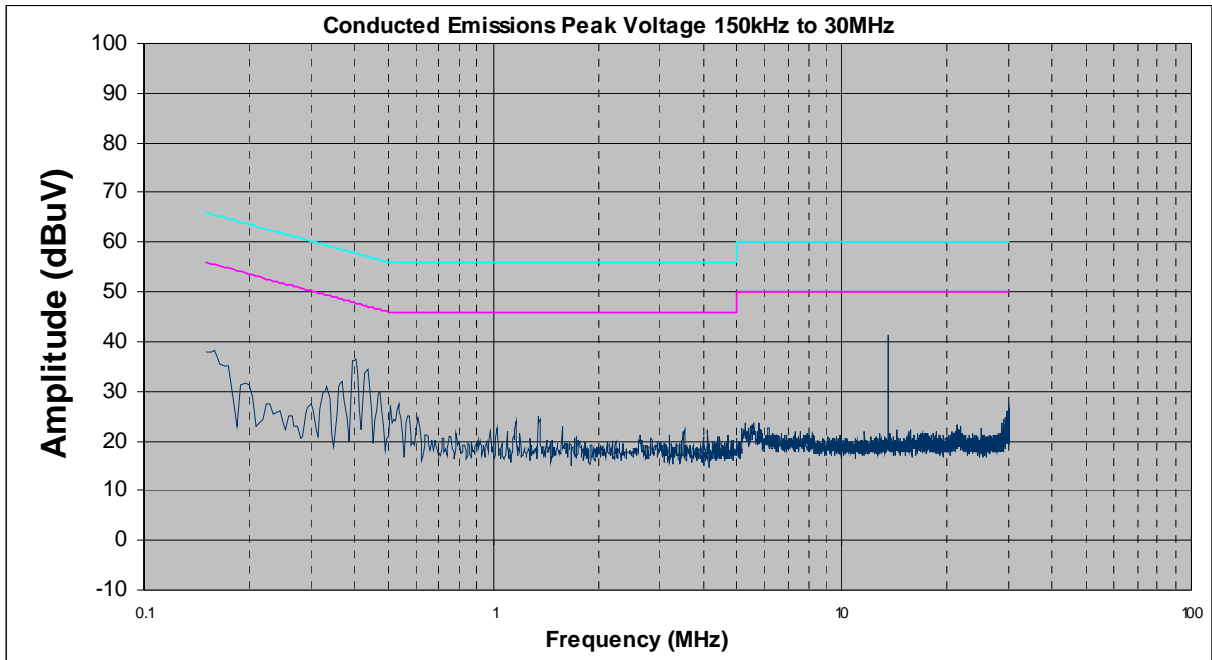

**Neutral Line Plot at 120Vac, 60Hz**

Line Under Test	Frequency (MHz)	Corrected Amplitude (dBuV) QP	Limit (dBuV) QP	Margin (dB) QP	Corrected Amplitude (dBuV) AVG	Limit (dBuV) AVG	Margin (dB) AVG
Neutral	13.55	41.40	60.00	-18.60	37.10	50.00	-12.90
Neutral	0.41	36.40	57.75	-21.35	32.40	47.75	-15.35
Neutral	0.44	34.50	57.06	-22.56	30.30	47.06	-16.76
Neutral	0.16	38.40	65.46	-27.06	34.30	55.46	-21.16
Neutral	0.33	31.00	59.45	-28.45	27.10	49.45	-22.35
Neutral	1.36	24.40	56.00	-31.60	21.30	46.00	-24.70



## 5.3 Radiated Emission within the Band of 13.110 – 14.010 MHz

**Requirement(s):** 47 CFR §15.225(a) – (c) & RSS-210 (A2.6)

**Procedures:** Radiated emissions were measured according to ANSI C63.4. The EUT was set to transmit at the highest output power. The EUT was set 3 meter away from the measuring antenna. The loop antenna was positioned 1 meter above the ground from the center of the loop. The measuring bandwidth was set to 10 kHz.

The limit is converted from microvolt/meter to decibel microvolt/meter.

Sample Calculation: Corrected Amplitude = Raw Amplitude (dBμV/m) + ACF (dB) + Cable Loss (dB) – Distance Correction Factor

**Results:**      **Loop Antenna Positioned at 0 degrees with RFID activated.**

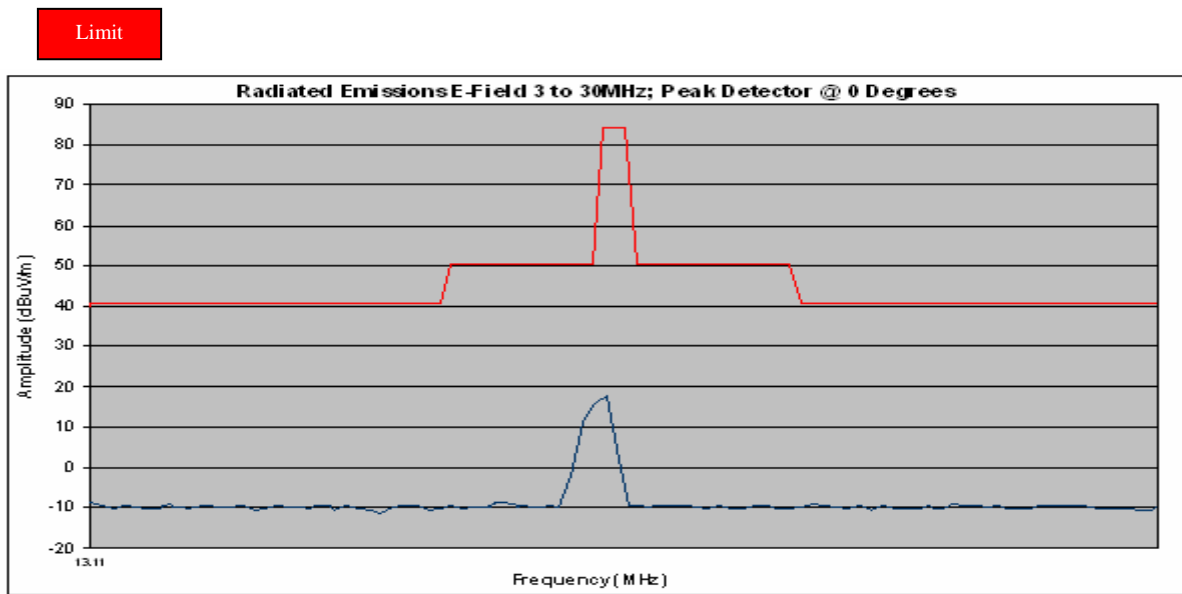

**Radiated Emissions Plot**

Frequency	Raw Amplitude @ 3m	Antenna Factor	Cable Loss	Distance Correction Factor	Corrected Amplitude @ 30m	Limit @ 30m	Margin
(MHz)	(dBμV/m)	(dB)	(dB)	(dB)	(dBμV/m)	(dBμV/m)	(dBμV/m)
13.56	17.56	35.61	0.28	40	13.45	84	-70.55

**Radiated Emissions Table**

**Results: Loop Antenna Positioned at 90 degrees with RFID activated.**

Limit

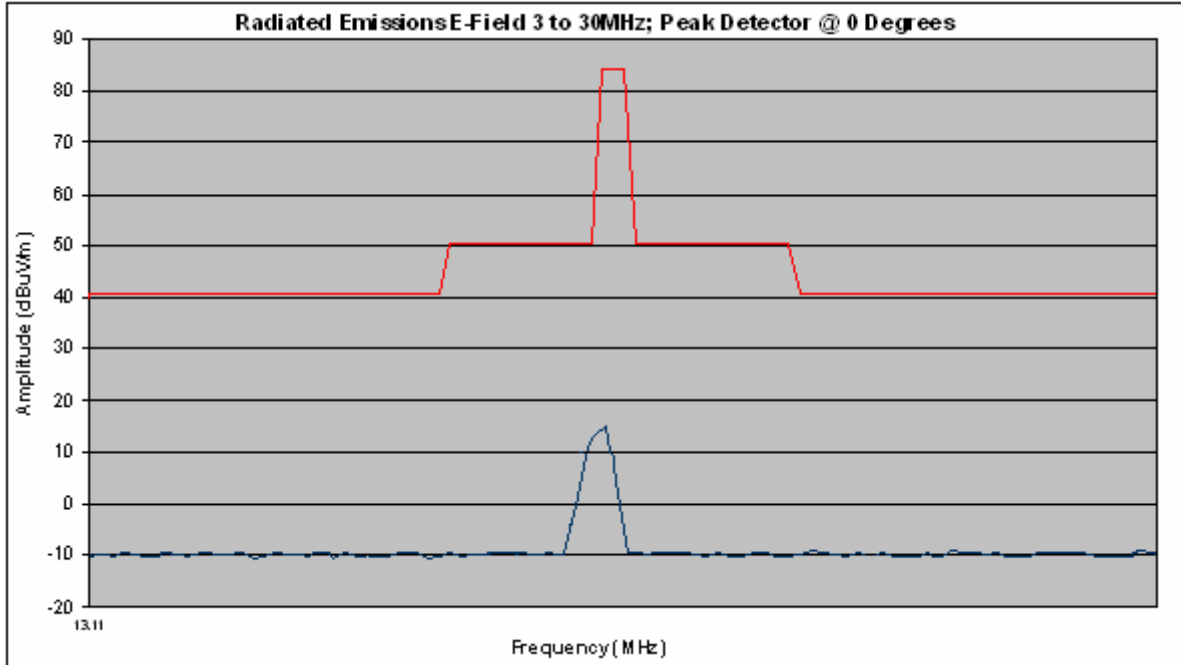

**Radiated Emissions Plot**

Frequency	Raw Amplitude @ 3m	Antenna Factor	Cable Loss	Distance Correction Factor	Corrected Amplitude @ 30m	Limit @ 30m	Margin
(MHz)	(dBµV/m)	(dB)	(dB)	(dB)	(dBµV/m)	(dBµV/m)	(dBµV/m)
13.56	15.86	35.61	0.28	40	11.75	84	-72.25

**Radiated Emissions Table**

## 5.4 Radiated Emissions < 30 MHz (outside 13.110 – 14.010 MHz)

**Requirement(s):** 47 CFR §15.209; 47 CFR §15.225(d) & RSS-210 (A2.6)

**Procedures:** Radiated emissions were measured according to ANSI C63.4. The EUT was set to transmit at the highest output power. The EUT was set 3 meter away from the measuring antenna. The loop antenna was positioned 1 meter above the ground from the center of the loop. The measuring bandwidth was set to 10 kHz.

The limit is converted from microvolt/meter to decibel microvolt/meter.

Sample Calculation: Corrected Amplitude = Raw Amplitude (dBμV/m) + ACF(dB) + Cable Loss(dB) – Distance Correction Factor

**NOTE:** All the test was done when the both radio was turn on to simulate the worst case.

**Results:** Loop Antenna Positioned at 0 degrees with RFID activated.

Limit

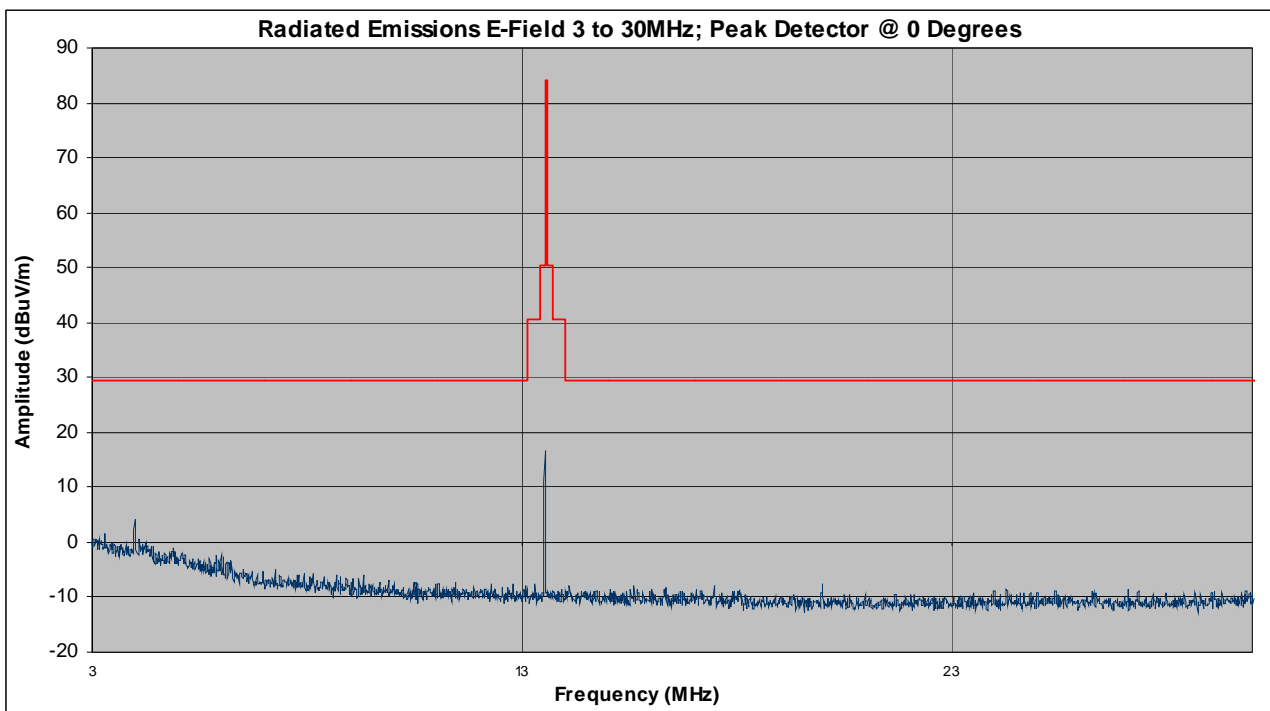

**Radiated Emissions Plot**

Frequency	Raw Amplitude @ 3m	Antenna Factor	Cable Loss	Distance Correction Factor	Corrected Amplitude @ 30m	Limit @ 30m	Margin
(MHz)	(dBμV/m)	(dB)	(dB)	(dB)	(dBμV/m)	(dBμV/m)	(dBμV/m)
3.99	4.3	44.29	0.24	40	8.83	29.54	-20.71

**Radiated Emissions Table**

**Results: Loop Antenna Positioned at 90 degrees with RFID activated.**

Limit

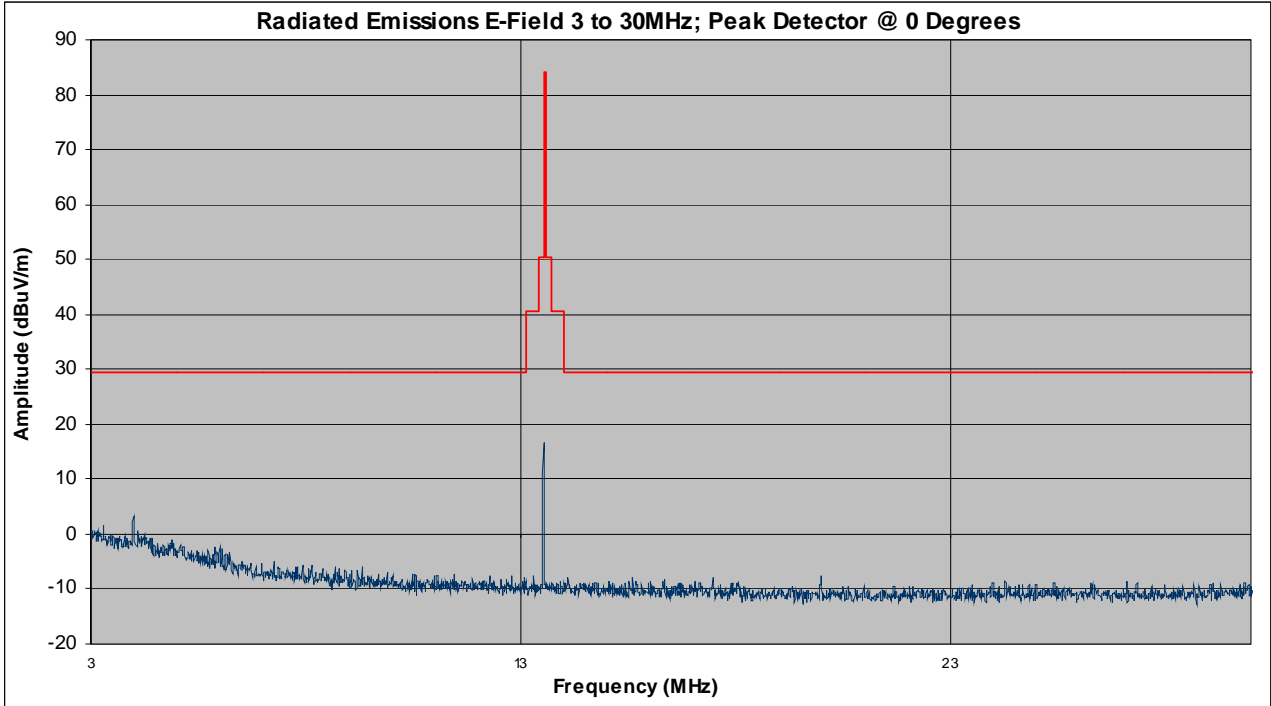

**Radiated Emissions Plot**

Frequency	Raw Amplitude @ 3m	Antenna Factor	Cable Loss	Distance Correction Factor	Corrected Amplitude @ 30m	Limit @ 30m	Margin
(MHz)	(dB $\mu$ V/m)	(dB)	(dB)	(dB)	(dB $\mu$ V/m)	(dB $\mu$ V/m)	(dB $\mu$ V/m)
3.99	3.1	44.29	0.24	40	7.63	29.54	-21.91

**Radiated Emissions Table**

## 5.5 Radiated Emissions > 30 MHz

**Requirement(s):** 47 CFR §15.209; 47 CFR §15.225(d) & RSS-210 (A2.6)

**Procedures:** Radiated emissions were measured according to ANSI C63.4. The EUT was set to transmit at the highest output power.

The limit is converted from microvolt/meter to decibel microvolt/meter.

Sample Calculation: Corrected Amplitude = Raw Amplitude (dBμV/m) + ACF (dB) + Cable Loss (dB)

**NOTE:** All the test was done when the both radio was turn on to simulate the worst case.

**Results:**

RFID is in transmitting mode

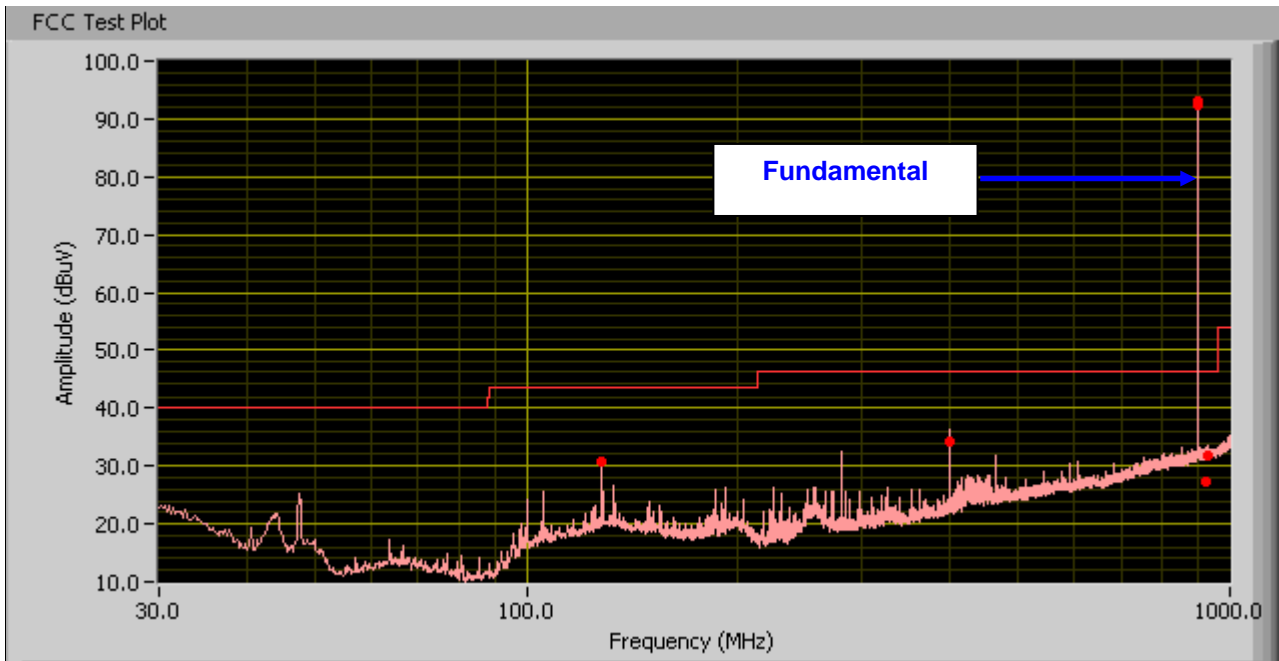

### Test Data

Frequency (MHz)	Quasi-Peak (dBμV/m)	Antenna height (cm)	Polarity	Turntable position (deg)	Limit (dBμV/m)	Margin (dB)
400.00	34.31	178.00	H	6.00	46.00	-11.69
128.00	30.90	244.00	H	146.00	43.50	-12.60
933.34	31.70	102.00	V	308.00	46.00	-14.30
925.34	27.35	320.00	V	138.00	46.00	-18.65
925.34	27.35	320.00	V	138.00	46.00	-18.65

## 5.6 Frequency Stability

**Requirement(s):** 47 CFR §15.225(e) & RSS-210 (A2.6)

**Procedures:** Frequency Stability was measured according to 47 CFR §2.1055. Measurement was taken with spectrum analyzer. The spectrum analyzer bandwidth and span was set to read in hertz. A voltmeter was used to monitor when varying the voltage.

Limit:  $\pm 0.01\%$  of 13.56 MHz = 1356 Hz

**Results:** RFID is activated

### Frequency versus Temperature

Reference Frequency: 13.56000 MHz at 20°C

Temperature (Celsius)	Measured Freq. (MHz)	Freq. Drift (Hz)	Freq. Drift (%)
50	13.558976	-1024	-0.00755
40	13.559009	-991	-0.00731
30	13.559026	-974	-0.00718
10	13.559026	-974	-0.00718
0	13.559018	-982	-0.00724
-10	13.559218	-782	-0.00577
-20	13.559326	-674	-0.00497
-30	13.559218	-782	-0.00577

### Frequency versus Voltage

Reference Frequency: measured 13.56000 MHz at 20°C with 120 Vac / 60 Hz

Measured Voltage $\pm 15\%$ of nominal (AC)	Measured Freq. (MHz)	Freq. Drift (Hz)	Freq. Drift (%)
138	13.559988	-12	-0.00009
102	13.559999	-1	-0.00001

**Annex A. TEST INSTRUMENT & METHOD**

**Annex A.i. TEST INSTRUMENTATION & GENERAL PROCEDURES**

Instrument	Manufacturer	Model	CAL Due Date
Spectrum Analyzer	HP	8568B	04/26/2008
Quasi-Peak Adapter	HP	85650A	04/26/2008
RF Pre-Selector	HP	85685A	04/26/2008
Spectrum Analyzer	HP	8564E	05/01/2008
EMI Receiver	Rohde & Schwarz	ESIB 40	04/25/2008
R&S LISN	ESH2-Z5	861741/013	04/27/2008
CHASE LISN	MN2050B	1018	04/26/2008
Biconlog Antenna	Sunol Sciences, Inc.	JB1	01/14/2009
Loop Antenna	ETS-Lingren	6512	05/13/2009
Chamber	Lingren	3m	09/28/2008
DMM	Fluke	73III	05/01/2008
Variac	KRM	AEEC-2090	See Note
Environment Chamber	Test Equity	1007H	01/24/2009

Note: Functional Verification

## Annex A.ii. CONDUCTED EMISSIONS TEST DESCRIPTION

### **Test Set-up**

1. The EUT and supporting equipment were set up in accordance with the requirements of the standard on top of a 1.5m x 1m x 0.8m high, non-metallic table, as shown in Annex B.
2. The power supply for the EUT was fed through a 50Ω/50μH EUT LISN, connected to filtered mains.
3. The RF OUT of the EUT LISN was connected to the EMI test receiver via a low-loss coaxial cable.
4. All other supporting equipments were powered separately from another main supply.

### **Test Method**

1. The EUT was switched on and allowed to warm up to its normal operating condition.
2. A scan was made on the NEUTRAL line (for AC mains) or Earth line (for DC power) over the required frequency range using an EMI test receiver.
3. High peaks, relative to the limit line, were then selected.
4. The EMI test receiver was then tuned to the selected frequencies and the necessary measurements made with a receiver bandwidth setting of 10 KHz. For FCC tests, only Quasi-peak measurements were made; while for CISPR/EN tests, both Quasi-peak and Average measurements were made.
5. Steps 2 to 4 were then repeated for the LIVE line (for AC mains) or DC line (for DC power).

### **Sample Calculation Example**

At 20 MHz	limit = 250 μV = 47.96 dBμV
Transducer factor of LISN, pulse limiter & cable loss at 20 MHz = 11.20 dB	
Q-P reading obtained directly from EMI Receiver = 40.00 dBμV (Calibrated for system losses)	
Therefore, Q-P margin = 47.96 – 40.00 = 7.96	i.e. <b>7.96 dB below limit</b>



**Annex A. iii RADIATED EMISSIONS TEST DESCRIPTION**

**EUT Characterisation**

EUT characterisation, over the frequency range from 30MHz to 10<sup>th</sup> Harmonic , was done in order to minimise radiated emissions testing time while still maintaining high confidence in the test results.

The EUT was placed in the chamber, at a height of about 0.8m on a turntable. Its radiated emissions frequency profile was observed, using a spectrum analyzer /receiver with the appropriate broadband antenna placed 3m away from the EUT. Radiated emissions from the EUT were maximised by rotating the turntable manually, changing the antenna polarisation and manipulating the EUT cables while observing the frequency profile on the spectrum analyzer / receiver. Frequency points at which maximum emissions occurred, clock frequencies and operating frequencies were then noted for the formal radiated emissions test at the Open Area Test Site (OATS).

**Test Set-up**

1. The EUT and supporting equipment were set up in accordance with the requirements of the standard on top of a 1.5m X 1.0m X 0.8m high, non-metallic table.
2. The filtered power supply for the EUT and supporting equipment were tapped from the appropriate power sockets located on the turntable.
3. The relevant broadband antenna was set at the required test distance away from the EUT and supporting equipment boundary.

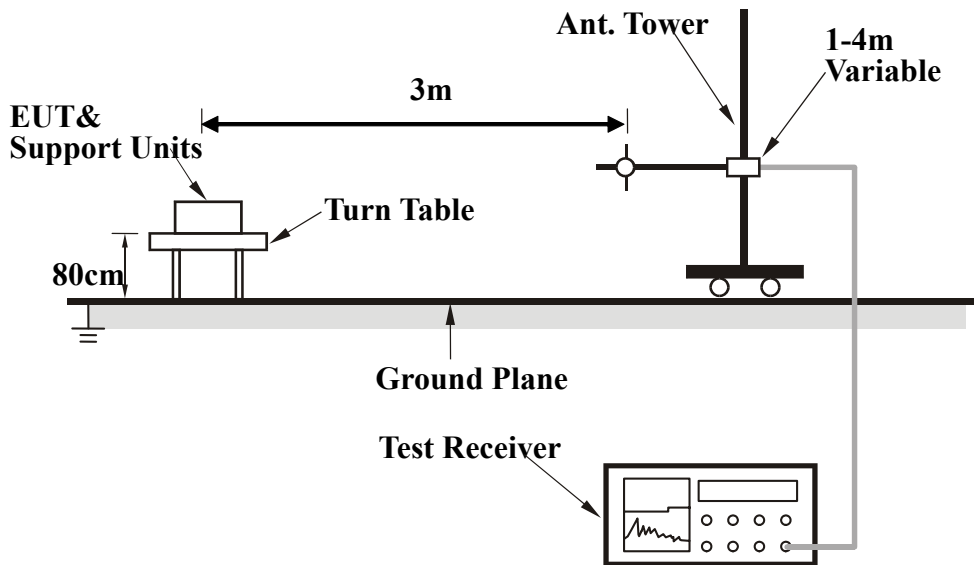

**Test Method**

The following procedure was performed to determine the maximum emission axis of EUT:

1. With the receiving antenna is H polarization, rotate the EUT in turns with three orthogonal axes to determine the axis of maximum emission.
2. With the receiving antenna is V polarization, rotate the EUT in turns with three orthogonal axes to determine the axis of maximum emission.
3. Compare the results derived from above two steps. So, the axis of maximum emission from EUT was determined and the configuration was used to perform the final measurement.

Final Radiated Emission Measurement

1. Setup the configuration according to figure 1. Turn on EUT and make sure that it is in normal function.
2. For emission frequencies measured below 1 GHz, a pre-scan is performed in a shielded chamber to determine the accurate frequencies of higher emissions will be checked on a open test site. As the same purpose, for emission frequencies measured above 1 GHz, a pre-scan also be performed with a 1 meter measuring distance before final test.
3. For emission frequencies measured below and above 1 GHz, set the spectrum analyzer on a 100 kHz and 1 MHz resolution bandwidth respectively for each frequency measured in step 2.
4. The search antenna is to be raised and lowered over a range from 1 to 4 meters in horizontally polarized orientation. Position the highness when the highest value is indicated on spectrum analyzer, then change the orientation of EUT on test table over a range from 0° to 360° with a speed as slow as possible, and keep the azimuth that highest emission is indicated on the spectrum analyzer. Vary the antenna position again and record the highest value as a final reading.
5. Repeat step 4 until all frequencies need to be measured were complete.
6. Repeat step 5 with search antenna in vertical polarized orientations.

During the radiated emission test, the Spectrum Analyzer was set with the following configurations:

Frequency Band (MHz)	Function	Resolution bandwidth	Video Bandwidth
30 to 1000	Peak	100 kHz	100 kHz
Above 1000	Peak	1 MHz	1 MHz
	Average	1 MHz	10 Hz

**Sample Calculation Example**

The field strength is calculated by adding the Antenna Factor and Cable Factor, and subtracting the Amplifier Gain (if any) from the measured reading. For the limit is employed average value, therefore the peak value can be transferred to average value by subtracting the duty factor. The basic equation with a sample calculation is as follows:

$$\text{Peak} = \text{Reading} + \text{Corrected Factor}$$

where

$$\text{Corr. Factor} = \text{Antenna Factor} + \text{Cable Factor} - \text{Amplifier Gain (if any)}$$

And the average value is

$$\text{Average} = \text{Peak Value} + \text{Duty Factor or}$$

$$\text{Set RBW} = 1\text{MHz, VBW} = 10\text{Hz.}$$

Note :

If the measured frequencies are fall in the restricted frequency band, the limit employed must be quasi peak value when frequencies are below or equal to 1 GHz. And the measuring instrument is set to quasi peak detector function.

**Annex B. EUT AND TEST SETUP PHOTOGRAPHS**

**Please see the attachment**

**Annex C. TEST SETUP AND SUPPORTING EQUIPMENT**

**EUT TEST CONDITIONS**

**Annex C. i. SUPPORTING EQUIPMENT DESCRIPTION**

The following is a description of supporting equipment and details of cables used with the EUT.

<b>Equipment Description (Including Brand Name)</b>	<b>Model &amp; Serial Number</b>	<b>Cable Description (List Length, Type &amp; Purpose)</b>
PC Laptop / DELL	Latitude DS520	USB Cable , 1meter From PC Laptop to EUT

### Block Configuration Diagram for Radiated Emission

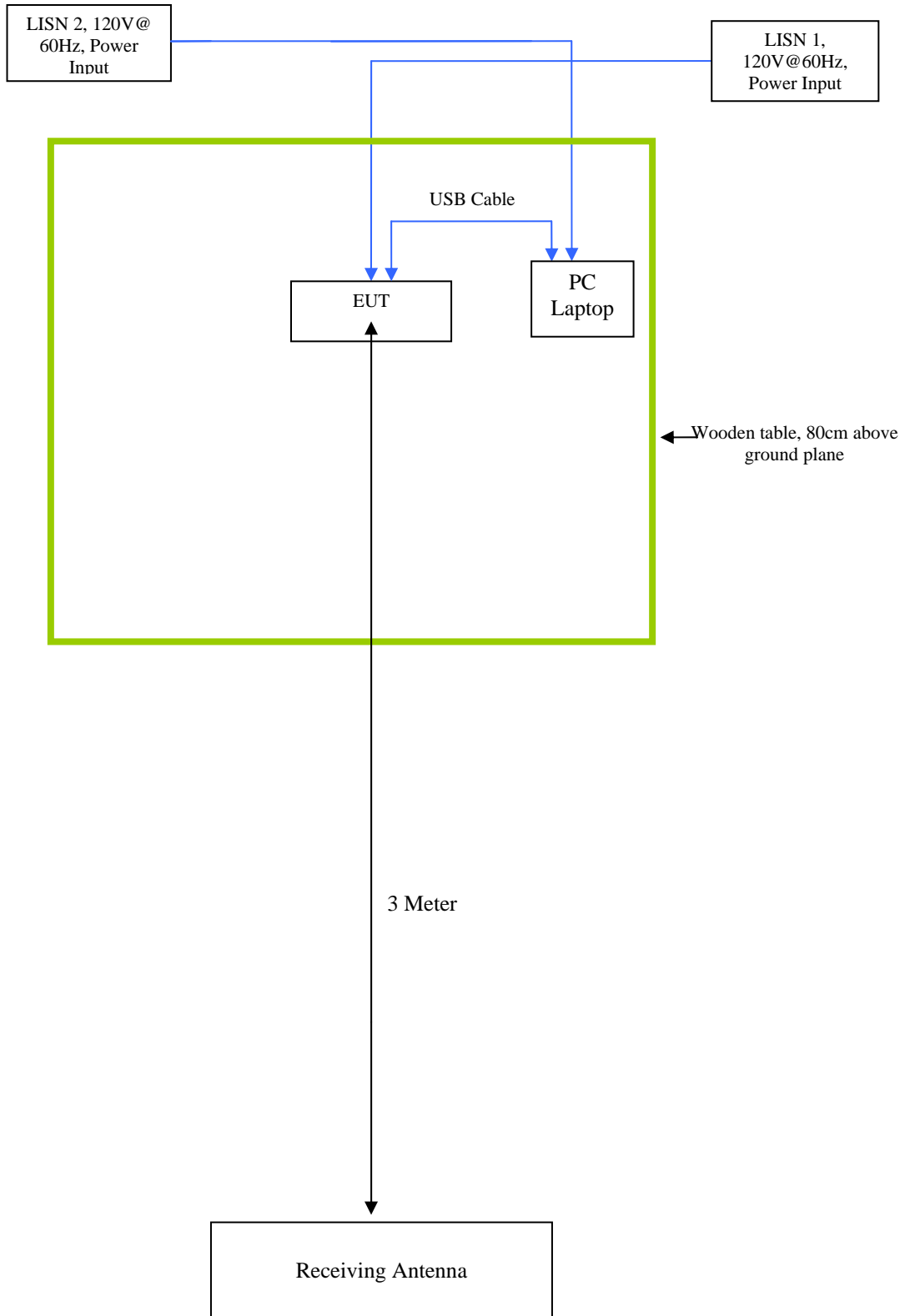

### Block Configuration Diagram for Conducted Emission

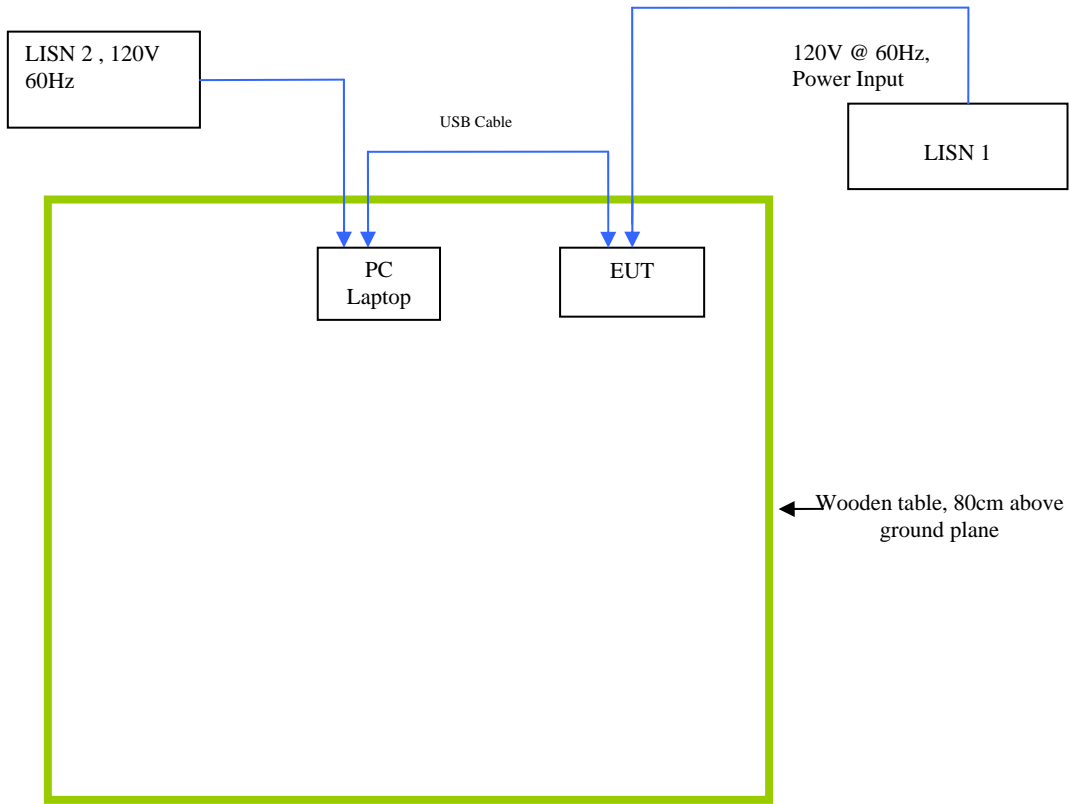

**Annex C.ii. EUT OPERATING CONDITIONS**

The following is the description of how the EUT is exercised during testing.

Test	Description Of Operation
<p><b>Emissions Testing</b></p> <p><b>Others Testing</b></p>	<p>The EUT was controlled via PC Laptop using Agency Testing Program provided by applicant.</p> <p>The EUT was controlled via PC Laptop using Agency Testing Program provided by applicant.</p>

## **Annex D USER MANUAL, BLOCK & CIRCUIT DIAGRAM**

**Please see attachment**