

**COMMANDER HF-2500/  
HF-2500 MAGNUM  
LINEAR AMPLIFIER**

**MADE IN THE U.S.A. BY HAMS FOR HAMS  
COMMAND TECHNOLOGIES, Inc.**

**15719 CR 2.50  
P. O. BOX 326  
EDON, OHIO 43518-0326  
419 459-4689  
800-736-0443**

## **THE COMMAND TECHNOLOGIES PHILOSOPHY**

The company was founded upon the guiding principle of providing amateur radio operators with better equipment at a lower cost.

That principle is evident in the company's products which have become known throughout the world for their superior value.

Value is defined by the company as a ratio of quality plus performance over cost. The higher the quality and/or performance or the lower the cost, the better the value.

Obviously, the limits of each parameter of the equation are subjective. For the company, quality limits are those which provide longevity and unquestioned performance benefits to the user without unnecessary cost burden. Performance is partly defined by governmental regulations and partly by the company's integrity of specifications. For example, power for Command Technologies linear amplifiers is specified by continuous carrier ratings - solid, meaningful figures which can be translated into benefits in the real world of amateur radio.

State-of-the-art technology has come to be a trite phrase, meaning different things to different people. To the company, it means today's proven technology, not gimmicks, which offer a facade with little of worth, or need, behind it. We may push the leading edge of technology in various ways, but it will be founded upon its value to the user in terms of performance and cost.

We appreciate your purchase of a Command Technologies product and assure you of continued factory support of your investment at all times.

Sincerely,

Patrick J. Stein  
N8BRA

# **SPECIFICATIONS**

## **COMMANDER HF-2500/ HF-2500 MAGNUM LINEAR AMPLIFIER**

**Band Coverage:** 160, 80, 40, 20, 17, and 15 meter amateur radio bands, 12 and 10 meter Export model; also useable in U.S.A. upon proof of proper license.

**Types of Emissions:** SSB, FM, CW, AM, RTTY, SSTV

**Driving Power Required:** 40 to 60 watts nominal at rated continuous carrier output

**Maximum Output Power:** 1500 watts Continuous Carrier, 1500 watts CW, 1500 watts Single Side Band

**Duty Cycle:** 100 percent in Amateur service at 1500 watts output power

**Harmonic Suppression:** Exceeds all F.C.C. Requirements

**Keying:** Requires contact closure of sinking +20 v dc at 300 ua. dc.

**Input Impedance:** 50 ohms unbalanced

**Output Impedance:** 50 ohms unbalanced: SWR 2:1 or less

**Metering:** Plate Voltage & Plate Current (switchable), Grid Current (continuous)

**A.L.C.:** Negative going, adjustable from rear panel

**Front Panel Controls:** Plate Voltage & Current Switch, On/Off Switch, Tune, Load, Band Selector Switch

**Rear Panel Controls:** Tuned Input Adjustment, A.L.C. Adjustment, R.F. Input, R.F. Output A.L.C. Output, Keying, +12v dc Auxiliary Source, Ground Connection, Line Cord, Fuse

**Tube Complement:** Two Eimac 3CPX800A7 Ceramic/Metal Triodes

**Power Requirement:** 200 / 234 Vac, 50/60 hz, 20 amperes

## Introduction

The Commander HF-2500/HF-2500 MAGNUM are class AB2 linear power amplifiers. They have been designed for operation on all amateur frequencies from 1.80 Mhz to 21.450 Mhz excluding the 30 meter band. Two Eimac 3CPX800A7 ceramic-metal triodes, configured in a grounded grid circuit, allows for conservative operation at 1500 watts continuous carrier output. A pressurized forced air cooled chassis, including the high voltage supply, insures cool operation with high duty cycle emission modes. The output circuit utilizes extra heavy duty components with reduced ratio drives on all tuning controls. Easily accessed rear panel controls allow for operator adjustment of input VSWR and ALC. An automatic time delay circuit, insures proper cathode conditioning before R.F. drive can be applied. A protection resistor, located in the high voltage B+ circuit, protects the tube in the event of an internal tube arc. Metering function includes plate voltage, plate current, and grid current.

## Unpacking instructions

Carefully remove the Commander HF2500/HF-2500 MAGNUM from its shipping carton. Make sure no shipping damage exists. If damage exists, **NOTIFY THE DELIVERING CARRIER IMMEDIATELY**. Describe fully the damage. Do not destroy the shipping carton or packing material. In the event you need to return your unit or wish to ship it to another location, the original shipping carton and packing material works best. Please retain your sales invoice. Should you ever need warranty service, it may be required to prove your date of purchase.

**!! WARNING !!**  
**CONTACT WITH VOLTAGES**  
**IN THIS AMPLIFIER CAN BE**  
**!!! FATAL !!!**

## Cautions and Warnings

Do not attempt any type of service or repair on this Amplifier without first removing the AC power and allowing at **LEAST 60 MINUTES FOR THE HIGH VOLTAGE CAPACITORS TO BLEED OFF !**

Make no attempt to put this Amplifier in service with the top or bottom covers removed. **CONTACT WITH VOLTAGES IN THE CABINET CAN BE FATAL !**

Never attempt operation without first connecting your amplifier to an appropriate antenna or dummy load. The antenna SWR should not exceed 2:1. The dummy load should have an impedance of 50 ohms with sufficient power handling capability. **DAMAGE TO THE AMPLIFIER MAY RESULT IF OPERATED WITHOUT A CONNECTION TO A PROPER LOAD.**

Never operate this amplifier without the ALC connected. Most modern transceivers have sufficient output power to seriously overdrive this amplifier. **THIS MAY RESULT IN DAMAGE TO EXPENSIVE COMPONENTS SUCH AS THE 3CPX800A7 TRIODE TUBES.**

**NEVER OPERATE THIS AMPLIFIER WITHOUT AN EARTH GROUND CONNECTED TO THE REAR PANEL GROUND TERMINAL.**

Do not obstruct the ventilation holes located on the top, bottom, and sides of the cabinet. These holes provide sufficient intake and exhaust of cooling air.

**SEVERE OVERHEATING AND SERIOUS DAMAGE WILL RESULT IF SUFFICIENT VENTILATION IS NOT PROVIDED.**

If any problem occurs which can not easily be corrected, contact the manufacturer for assistance.

## Accessory warnings

Your new Commander HF-2500/HF-2500 MAGNUM has the capability of 1500 watts output continuous carrier without time limit. Many accessories such as power meters, traps, and baluns have power ratings for the old 1,000 watt input (600 watt output) power restriction. The 1500 watt continuous carrier output capability of the Commander HF-2500/HF-2500 MAGNUM may destroy these accessories. If you are in doubt about the power handling capability of a particular accessory, contact the original manufacturer, or use the accessory at reduced output power. When in doubt, do not use an accessory with this amplifier. **FAILURE OF AN ACCESSORY MAY CAUSE DAMAGE TO THE COMMANDER HF-2500/HF-2500 MAGNUM.**

**COMMAND TECHNOLOGIES INC.**

**15719 CR 2.50  
P.O. BOX 326  
EDON, OHIO 43518**

**TEL: 419-459-4689**

**TRANSFORMER INSTALLATION**

When mounting the hypersil transformer, place the HF-2500\HF-2500 MAGNUM so the front panel faces your body. Align the transformer so the Danger High Voltage label reads right. The wire leads coming out of the transformer should be to the rear and the connector to the right. place the transformer in the unit aligning the transformer's mounting holes to the mounting holes on the bottom of the chassis. Place the 1/4 - 20 screws threw the mounting holes and chassis and secure with the 1/4 - 20 nuts and washers. Connect the male-female "mate & lock" connector. Push hard to insure that the two halves are locked together. The transformer should now be installed and ready for use.

**TUBE INSTALLATION**

Carefully remove the 3CPX800A7 tubes from their shipping carton. This carton was located in the area where the transformer was installed. Place the tubes in the tube sockets with the proper pin alignment. If you have maintained the proper pin alignment, the tubes should go into their sockets easily. If you have to use undue pressure to insert the tubes, you may have the wrong pin alignment or one of the pins may be bent. If necessary straighten pins with needle nose pliers and reinstall. Install the parasitic chokes on the tube caps and replace the top and bottom covers. When you reinstall the top and bottom covers it may be necessary to use an awl to align the screws.

## **Connection Diagram High Speed Switching**

Connect the RF output of your transceiver to the RF IN connector on the rear of the HF-2500\HF-2500 MAGNUM with 50 ohm coax. Connect the existing station antenna system to the RF OUT connector on the HF-2500\HF-2500 MAGNUM with RG-8 type coax. Connect the RELAY phono jack on the rear of the HF-2500\HF-2500 MAGNUM to the normally open terminal of the RELAY jack on your transceiver. The RELAY jack on the HF-2500\HF-2500 MAGNUM has positive 20 VDC open circuit and requires the sinking of 300 UA of current when pulled to ground. Connect as short a ground lead as possible from a good earth ground to the GROUND post on the HF-2500\HF-2500 MAGNUM. The 12 VDC phono jack on the HF-2500\HF-2500 MAGNUM rear panel provides 12 VDC at 100 MA maximum to operate external accessories or dial lamps. Connect the ALC phono jack to the ALC connection on your transceiver using a shielded type cable. Consult your transceiver manual for proper ALC connection details.

## TUNING PROCEDURE

1. Set the front panel controls to the following positions:

ON - OFF Switch.....OFF  
STANDBY - OPERATE.....STANDBY  
METER SWITCH.....Vp  
BAND SWITCH.....DESIRED BAND  
TUNE CONTROL.....LOG SCALE ON DATA SHEET  
LOAD CONTROL.....LOG SCALE ON DATA SHEET

2. After you have preset the above controls and the amplifier is properly connected to a suitable load, switch the ON - OFF to the on position. The blower should be running and the meter lamps should also be lit. The meter should read a plate voltage of approximately 2600 volts DC. (3400v on HF-2500 MAGNUM)

3. After a little more than 2 minutes the green power lamp should come on signifying the amplifier is ready for operation. Place the meter switch in the Ip position and the standby - operate to the operate position. Key the exciter with no rf drive applied. The red transmit lamp should light, and an indication of approximately 250 ma plate current on the meter. Apply 5 to 10 watts of rf drive, the plate current should rise slightly. If the plate current rises above 600 ma. reduce drive. Adjust the tune control for a peak on the grid meter and maximum output as indicated on an external wattmeter.

4. Adjust the load control for maximum output as indicated on an external wattmeter. Next, while increasing the drive in small increments adjust the load control counter clockwise for maximum output and to keep the grid current below 60 ma. Readjust the tune control clockwise to again peak the reading on the grid meter. If the meter rises above 60 ma quickly reduce drive and adjust the load control counterclockwise to reduce grid current. Never exceed 100 ma of grid current. Repeat these adjustments as required to achieve the desired output up to 1500 watts. Note that when increasing output power the tune scale will always read higher and the load will read lower. Also the supplied inspection sheet has all the of these settings and they should be used as a guide for this procedure. If your settings vary widely from these you have something wrong and should start over.



## TUNING PROCEDURE CONTINUED

5. If your planned operation is on SSB, you should adjust the load control slightly counter-clockwise, reducing the output slightly about 30 to 50 watts. This adjustment is necessary to insure that the amplifier is sufficiently loaded to handle the plate current peaks caused by the complex voice patterns during SSB operation. Nominal plate and grid current readings during SSB operation will be about 30 to 40% of the key down CW readings.

**CAUTION:** THE TUNE AND LOAD AIR VARIABLE CAPACITORS MAY ARC IF MAXIMUM DRIVE IS APPLIED BEFORE THE AMPLIFIER IS PROPERLY TUNED. ALWAYS FOLLOW THE DESCRIBED TUNE UP PROCEDURE TO AVOID CAPACITOR ARCING. ARCING MAY ALSO OCCUR IF YOU ATTEMPT TO TUNE INTO AN ANTENNA WITH A VSWR GREATER THAN 2:1.

If you should need any further assistance tuning this amplifier, feel free to call us here at 1-800-736-0443 and our staff will be happy to help you. If you are outside the United States we are available at 011-419-459-4689.

## Theory Of Operation

The Commander HF-2500\HF-2500 MAGNUM uses a pair of C.P.I. Eimac 3CPX800A7 ceramic/metal triodes in a class AB2 grounded grid configuration. Nominal drive power of 50 to 60 watts will deliver 1500 watts of clean RF output power. This amplifier will operate on the following amateur bands: 160,80,40,20,17, and 15 meters. (12 and 10 meters with authorized modification) . File copy of proper license is required for these instructions. Operation of this amplifier on the 11 meter (citizen band) is not possible as this unit employs RF chokes with series resonance within this band. Attempted operation will cause serious damage that will not be covered under warranty.

## Metering Functions

The Commander HF-2500\HF-2500 MAGNUM has two illuminated panel meters. The Grid Current meter provides a continuous reading of the 3CPX800-A7 grid current. The meter scale is 2 MA per division, the range is 0 to 200 MA. **DO NOT EXCEED 100 MA OF GRID CURRENT. DAMAGE TO YOUR TUBES COULD RESULT.** Under typical operating conditions the grid current will be 30-50 MA . Plate voltage and Plate current are shown on the second meter. A function switch on the front panel switches the meter from plate voltage to plate current. Plate current is shown on the top scale. Each division is 30 MA, and full scale is 1,500 MA. The typical plate current under nominal rated output (1500 Watts) should range from 1000 MA to 1200 MA on the HF-2500, and 700 MA to 800 MA on the HF-2500 MAGNUM. with an absolute maximum of 1500MA. for SSB. Plate voltage is indicated on the bottom scale with each division reflecting .06 KV. The scale has a range from 0-3.0 KV (0-3.5 KV HF-2500 MAGNUM). The nominal no-load plate voltage on the HF-2500 should read approximately 2,600 volts, with 3,400 volts on the HF-2500 MAGNUM. Plate voltage under nominal full load should read approximately 2,300 volts (3,200 volts HF-2500 MAGNUM).

## **TUNED INPUT CIRCUITS**

The tuned input circuits utilize an L-C-L or "T" impedance matching circuit with a high "Q" design. These circuits employ RF phase compensating capacitors to reduce intermodulation products. The use of mica trimmer type capacitors allows adjustments to precisely match the transceiver to the amplifier. The rear panel provides easy access to these trimmer capacitors. A front panel switch selects the proper input filter by grounding an associated relay coil.

### **Tuned Input Adjustments**

Your Commander amplifier has mica trimmer capacitors which are easily accessed thru holes located on the rear panel. The tuned input circuits are factory tuned and should not require any readjustment. You can easily make adjustments for any change in your preference for operating frequency range. Also, slight adjustments may be necessary because of slight variances in impedances between your transceiver and the tuned input circuitry of the amplifier.

1. Install a SWR meter between the transceiver and the amplifier.
2. Make sure the Operate/Standby switch is in the operate position and the band switch is set to the same band as the one for which you are making adjustments. Your amplifier should also be properly tuned and loaded.
3. Apply drive and observe the SWR, and adjust the trimmer capacitor for minimum SWR. Be careful not to overdrive the amplifier.
4. Repeat this procedure each band.

## **AUTOMATIC DRIVE LIMITING CONTROL**

An adjustable automatic level control (ALC) circuit limits the peak output power. When properly set, this circuit insures that the amplifier can not be overdriven. Rear panel access allows for easy manual adjustment . A sample of the RF input derives the ALC voltage. Additionally this amplifier has an RF negative feedback resistance in the cathode circuit to help cancel excessive RF drive without reducing the amplifier's gain.

### **A.L.C. ADJUSTMENTS**

Your transceiver's internal ALC will maintain linearity. The amplifier's ALC will prevent overdriving the amplifier. The HF-2500\HF-2500 MAGNUM's ALC circuit was designed for negative going ALC voltage. Proper adjustment is as follows:

1. Use an insulated tool when making these adjustments.
2. Tune the amplifier for operation on the 20 meter band for full 1500 watts output.
3. With your transceiver set for 20 meter SSB operation, set the transceiver's microphone gain for normal operation as specified in its owners manual.
4. While speaking louder than normal into the microphone, adjust the ALC POT on the rear panel thru the access hole. Adjust for 1500 watts maximum output as indicated on an external peak reading wattmeter. If an average reading wattmeter is used, adjust for approximately 750 watts output on voice peaks.
5. On some of the late model transceivers this adjustment can be adjusted in the CW position. On these models (with your output at 1500 watts) simply adjust for a slight drop in output.

## **OUTPUT FILTER CIRCUIT**

The PI variable network filter transforms the plate load impedance from approximately 2,500 ohms down to 200 ohms. Two air variable capacitors, and an associated inductor, accomplish this transformation. A heavy duty band switch selects the proper inductance from two high "Q" inductors. Each inductor contains taps for the desired band. A design "Q" of 14 allows for good harmonic attenuation on all bands. The utilization of a special reactance tuned ferrite core, 4 to 1 transmission line transformer, transforms the nominal 50 ohm antenna impedance up to the 200 ohm output of the PI circuit. This also provides further harmonic attenuation of the output, in the same manor, as an "L" coil in a Pi - L network.

## **HIGH VOLTAGE SUPPLY**

The high voltage supply operates from 200/234 Vac. 20 ampere line. The primary of the high voltage transformer is switched on/off with solid state relays, that only conduct when the phase angle of the AC power line is at zero degree crossover. This minimizes line surge and inrush current, while the high voltage filter capacitors charge. The front panel on/off switch activates the solid state relays with 2ma AC to turn the unit on. Approximately 900 volts AC is applied to a full wave voltage doubler rectifier circuit. (On the HF-2500 MAGNUM, 2400 volts AC is applied to a full wave bridge). This supplies approx. 2600 volts DC to the 3CPX800-A7 anode. Metering of the tube anode and grid current is accomplished by shunt resistors located in the negative return of the 3CPX800-A7 cathode. Plate voltage metering is accomplished by a resistor multiplier network in the B+ line of the high voltage circuit.

## Limited Warranty

Command Technologies, Inc. warrants to the original purchaser, that our Commander Amplifiers shall be free from defects in material, except Eimac 3CPX800A7 tubes, or workmanship for five (5) years from the date of original purchase. Tubes are covered by warranty granted from their manufacturer.

During the warranty period, Command Technologies, Inc. will correct defects in material and workmanship. Original purchaser will pay all shipping charges. Command Technologies, Inc. provides warranty parts and services according to the following schedule:

1st year.....	100% parts and labor
2nd year.....	50% parts and labor
3rd,4th and 5th year.....	25% parts and labor

to obtain such warranty service, the purchaser must:

1. Notify Command Technologies as soon as possible after the discovery of possible defect of:
  - a. The model number and serial number
  - b. Approximate date of purchase
  - c. A detailed description of the problem
2. Deliver the product to Command Technologies service facility, or ship the same in its original container or equivalent, fully insured and shipping charges prepaid.

Correct maintenance, repair, and use are important to obtain proper performance from this product. Therefore, carefully read the Instruction Manual. This warranty does not apply to any defect that Command Technologies, Inc. determines is due to :

1. Improper maintenance or repair including the installation of parts or accessories that do not conform to the quality and specifications of the original parts.
2. Misuse, abuse, neglect or improper installation.
3. Accidental or intentional damage.

All implied warranties, if any, terminate five years form the date of the original purchase.

The foregoing constitutes Command Technologies entire obligation with respect to the product, and the original purchaser and any user or owner shall have no other remedy and no claim for incidental or consequential damages. Some states do not allow limitations on how long an implied warranty lasts or do not allow the exclusion or limitation of incidental or consequential damage, so the above limitation and exclusion may not apply to you.

This warranty gives specific legal rights, and you may also have other rights which vary from state to state.

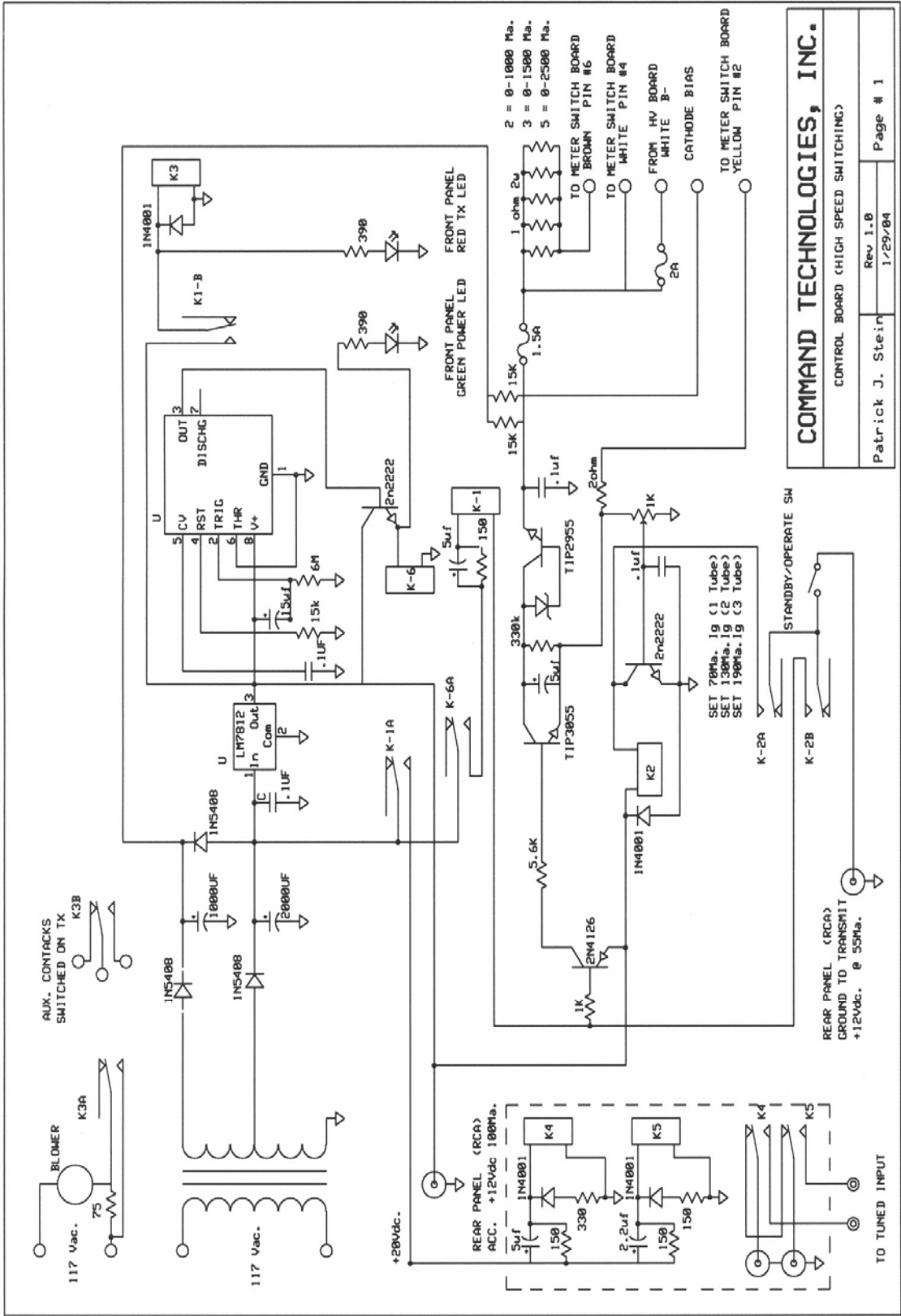

**COMMAND TECHNOLOGIES, INC.**  
 CONTROL BOARD (HIGH SPEED SWITCHING)  
 Patrick J. Stein      Rev 1.0      Page # 1  
 1/29/04

C:\Program Files\ExpressPCB\CONTROL2.sch - Sheet1

D48-5

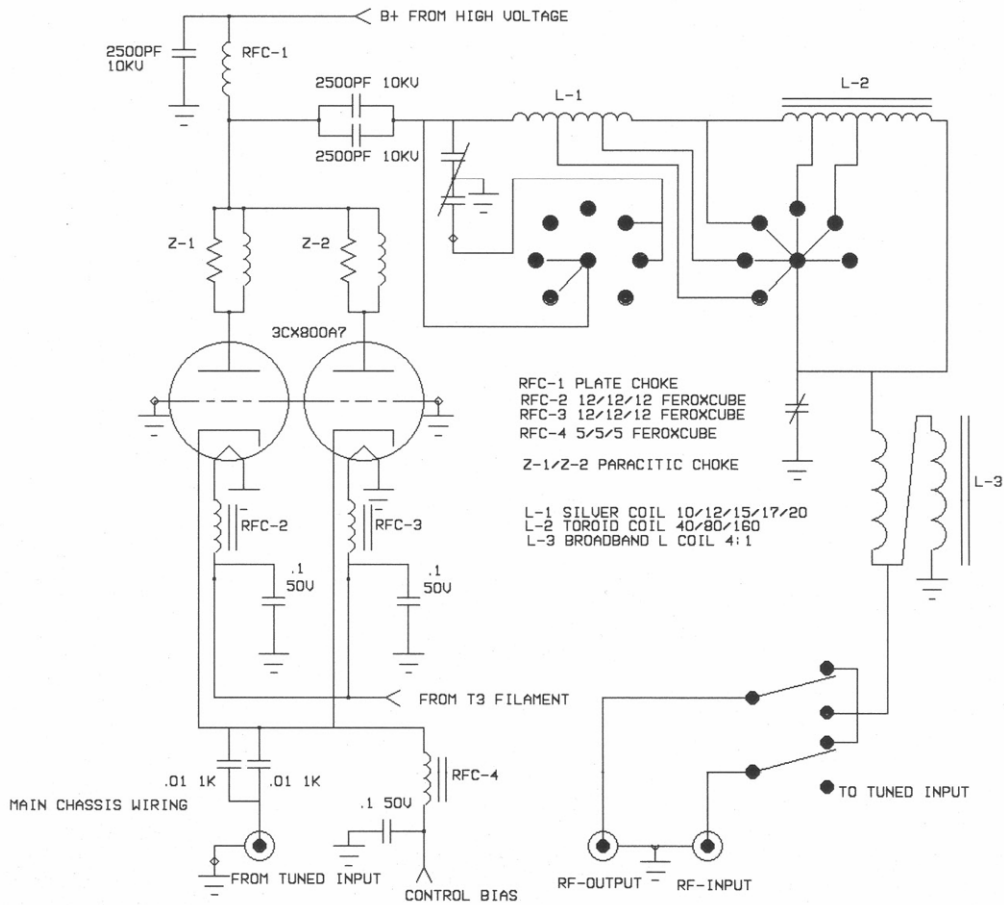
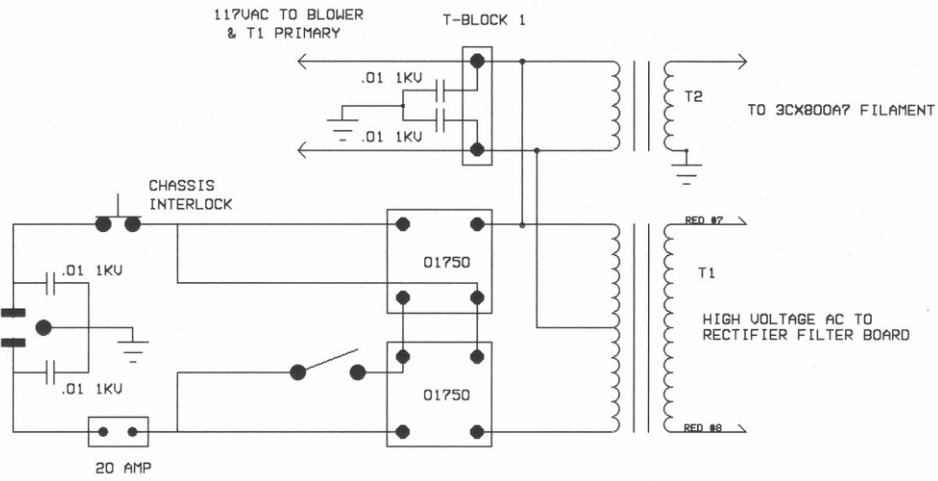



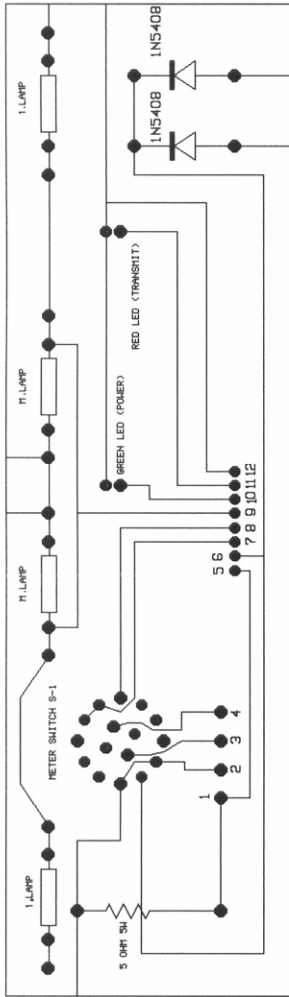

### SWITCH BOARD DETAIL

- 1 - ORANGE GRID METER +
  - 2 - YELLOW GRID METER -
  - 3 - UP/IP METER -
  - 4 - UP/IP METER +
  - 5 - YELLOW GRID FROM CONTROL BOARD
  - 6 - WHITE B- FROM CONTROL BOARD
  - 7 - BROWN PLATE CURRENT SHUNT
  - 8 - YELLOW HV MULTIPLIER
  - 9 - ORANGE +12 UDC
  - 10 - BLUE POWER LED
  - 11 - PURPLE TRANSMIT LED
  - 12 - GREEN GROUND
- S1=81F1018 (01865)

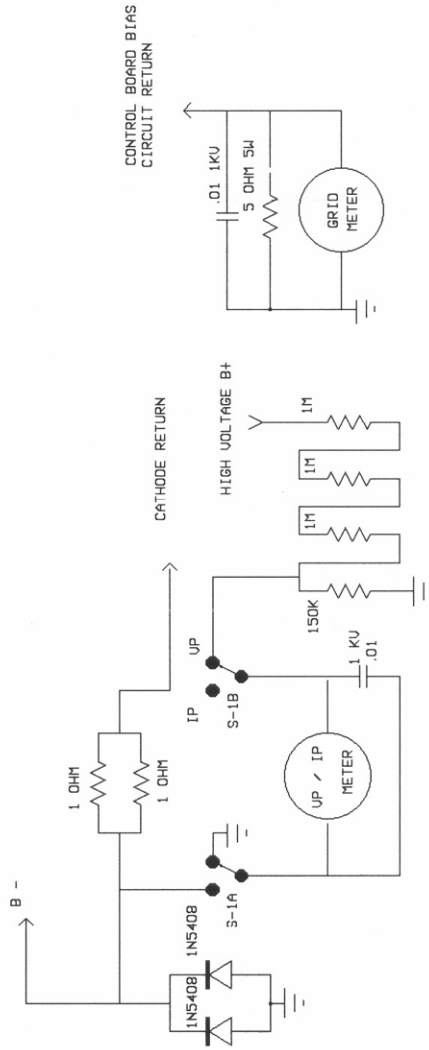

### METER CIRCUIT DETAIL 6/16/95

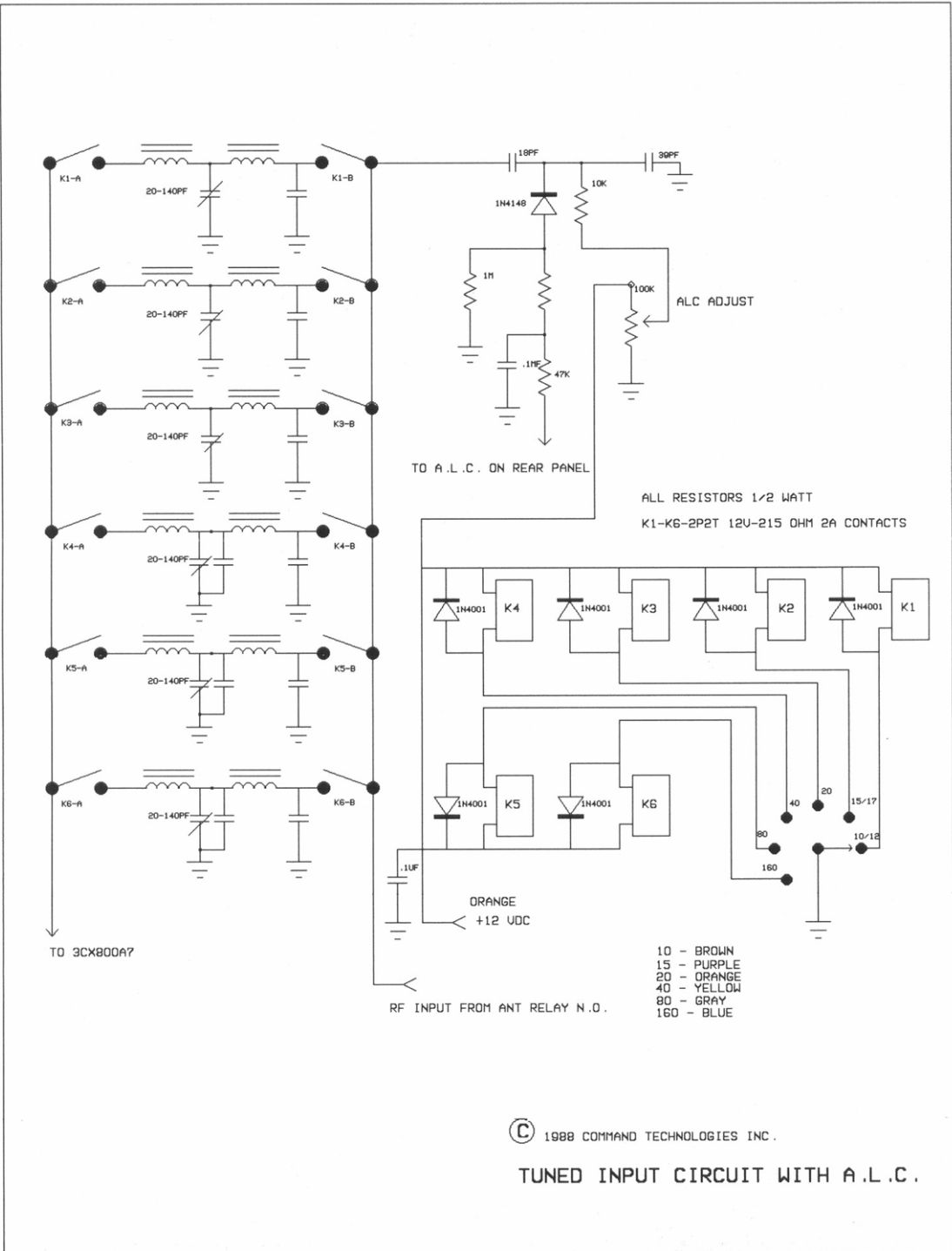

© 1988 COMMAND TECHNOLOGIES INC.

TUNED INPUT CIRCUIT WITH A.L.C.

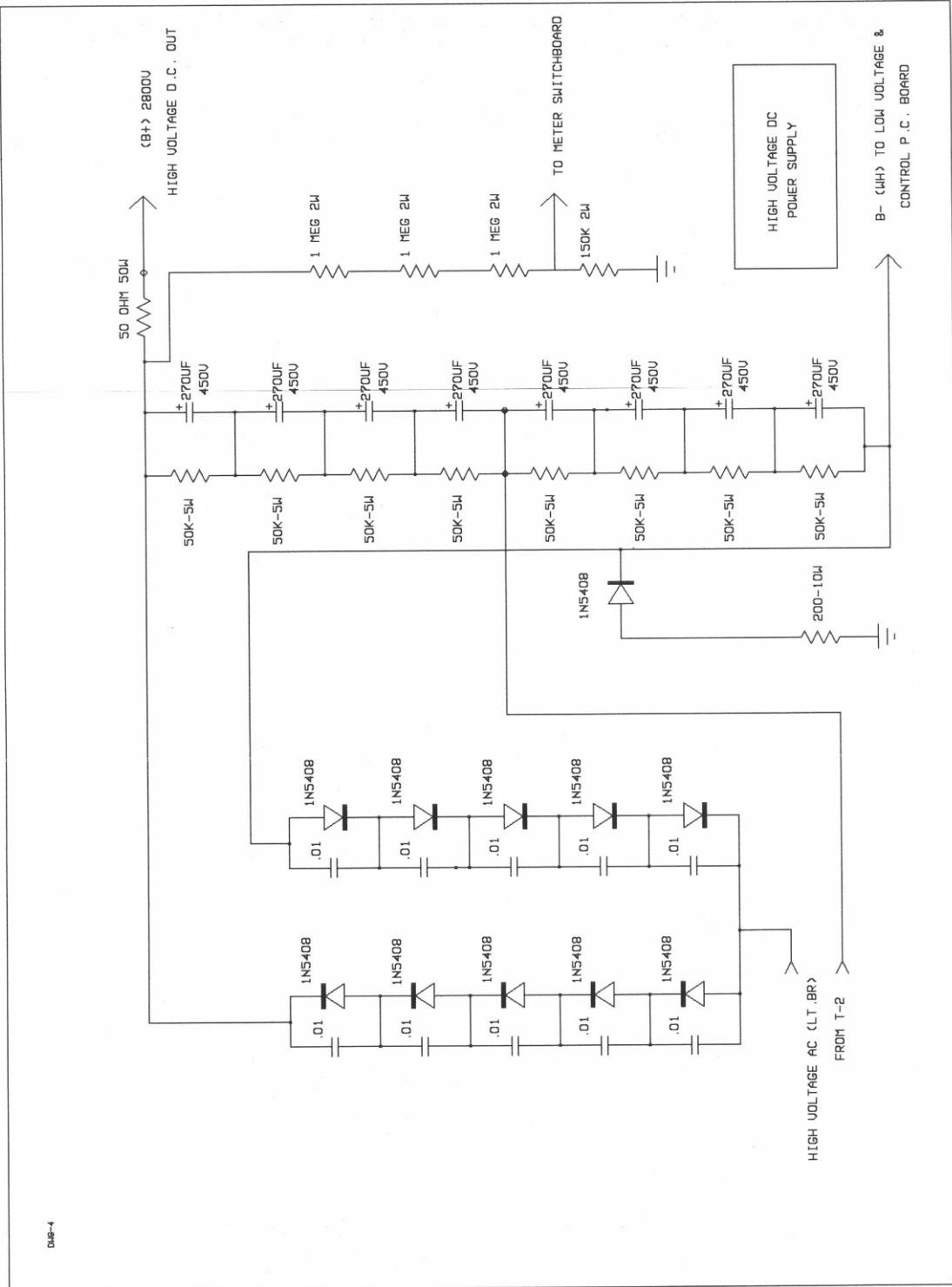

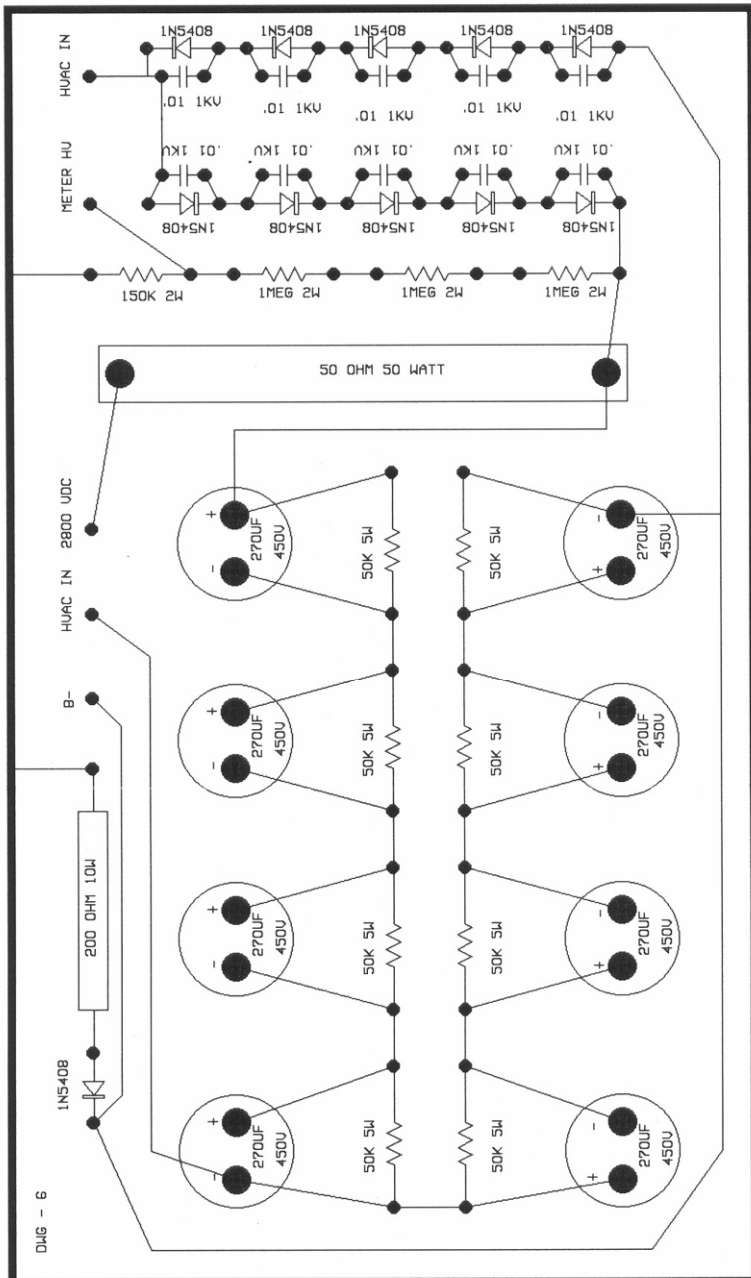

DIAG - 6

HIGH VOLTAGE CIRCUIT  
DETAIL 6 - 1995

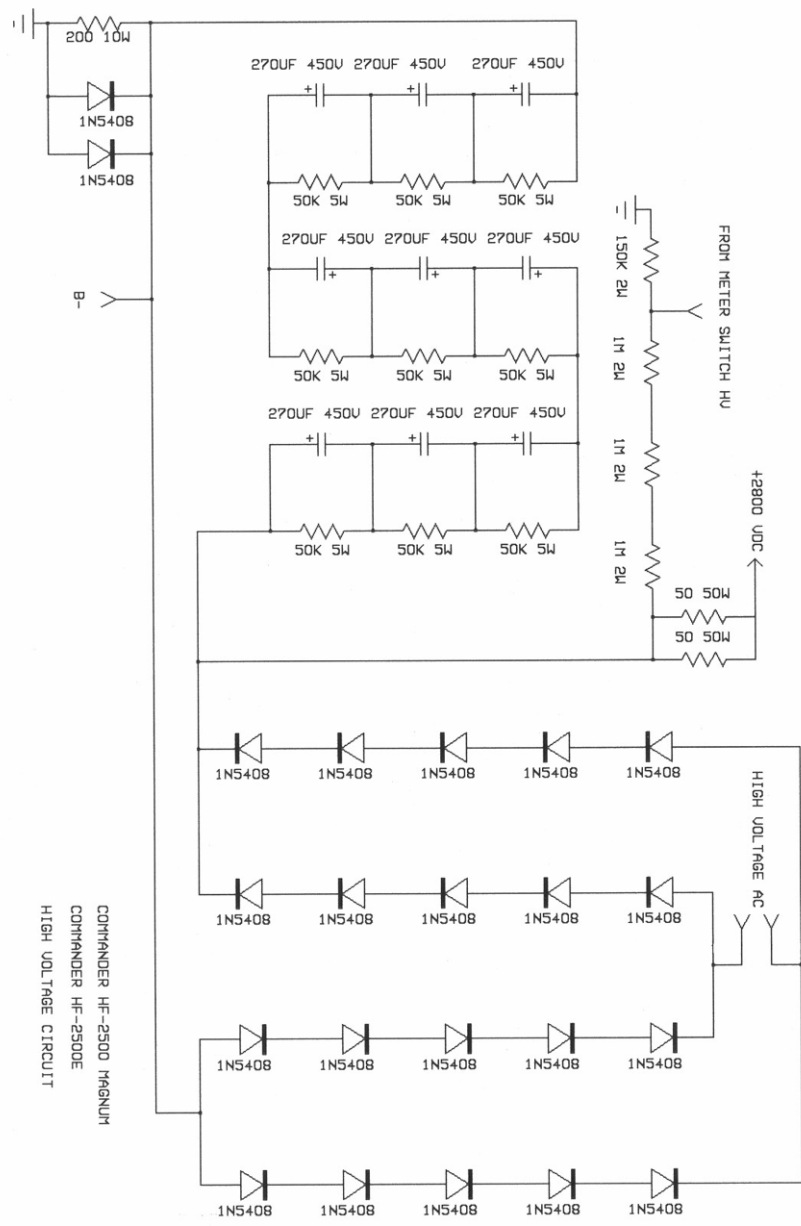

COMMANDER HF-2500 MAGNUM  
 COMMANDER HF-2500E  
 HIGH VOLTAGE CIRCUIT

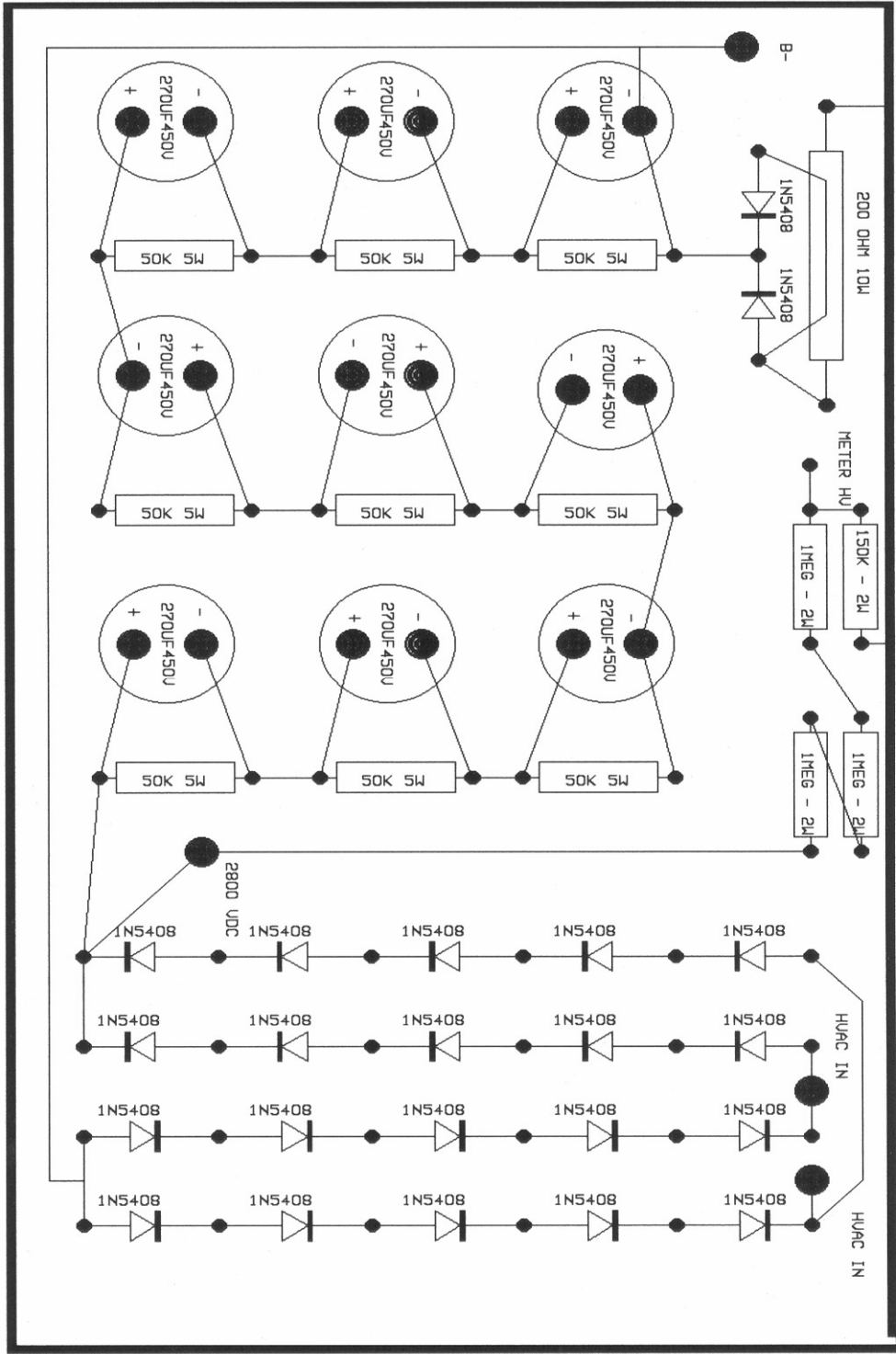

HIGH VOLTAGE CIRCUIT  
 DETAIL 6 - 1995