

To download locally to an SU:

1. From the SU 1.4 or 1.5 Console, select the **Download** menu.
2. Select **Local Firmware**.
3. From the **Look In** search field, choose the binary file to be downloaded (**PMP\_SU\_release1-3.mot**) from the appropriate directory and click **Select**. The download requires about 2 minutes. Once the download is complete, the banner indicating **Version 1.3** is displayed.

If the download does not complete successfully, as indicated by a checksum mismatch or a failure to reboot, cycle power to the SU and repeat, starting at step 1.

## Local Download to the BSU

Use this download method to upgrade BSUs after the SUs have been upgraded to Version 1.3. The BSU is upgraded through its Ethernet/Power cable using the BSU 1.4 or 1.5 Console.

To locally download to the BSU:

1. From the BSU 1.4 or 1.5 Console, select the **Download** menu.
2. Select **Local Firmware**.
3. From the **Look In** search field, choose the binary file to be downloaded (PMP\_BSU\_release1-3.mot) from the appropriate directory and click **Select**.
4. Once the upgrade is successful, if there were SUs connected to the BSU, they will re-acquire net entry. For each SU connection, two messages are displayed:
  - 120 Received NetEntry Request from Eth<SU's Ethernet address>
  - 121 NetEntry completed: Assigned terminal ID<ID#>, VLAN ID 1, IP<SU's IP address>

It normally takes less than a minute and a half for the SUs to re-acquire NetEntry with the BSU from the time the local download started.

5. If there were no SUs connected to the BSU, after the upgrade succeeds, the version banner is displayed with version 20021300, following by three messages:
  - 114 Completed flash sector verification
  - 103 DB check completed
  - 107 Save NV configuration Parameters

Once the SUs are re-connected to the BSU, expect the same behavior as specified in step 4.

## Appendix C. Technical Specifications

The following technical specification is for reference purposes only. Actual product performance and compliance with local telecommunications regulations can vary from country to country. Proxim Corporation only ships products that are type approved in the destination country.

### Burst-Rate Limit

Product	Burst-Rate Limit	Model Number
Base Station Unit	60 Mbps 20 Mbps	40400-65 (also supports 20-40 Mbps burst rates) 40400-25
Subscriber Unit	60 Mbps 40 Mbps 20 Mbps	40100-65x (also supports 40-20 Mbps) 40100-45x (also supports 30-20 Mbps) 40100-25x

### Downlink/Uplink Throughput

Burst Rate	D/L Throughput	U/L Throughput
20 Mbps	9 Mbps	8 Mbps
30 Mbps	13.5 Mbps	12 Mbps
40 Mbps	18 Mbps	16 Mbps
60 Mbps	27 Mbps	24 Mbps

**Note:** The above calculations are typical and based upon a 50/50 downlink (D/L) uplink (U/L) division of slots (see "firstinboundSlot Command" in the *Tsunami Multipoint Version 1.3 Reference Manual*). SU throughput may be limited by a provider's Service Level Agreement or other D/L U/L settings.

### Frequency Plans

The following table defines the frequencies associated with each plan.

Channel Plan	Frequency
4A	5743.86 MHz
4B	5764.61 MHz
4C	5785.36 MHz
4D	5806.11 MHz

Channel Plan	Frequency
5A	5742.19 MHz
5B	5758.79 MHz
5C	5775.39 MHz
5D	5791.99 MHz
5E	5808.59 MHz

Channel Plan	Frequency
6A	5740.40 MHz
6B	5754.23 MHz
6C	5768.07 MHz
6D	5781.90 MHz
6E	5795.73 MHz
6F	5809.57 MHz

## Tx Power

BSU .....+6 to +18 dBm (into antenna port)

SU .....-48 to +17 dBm (into antenna port)

## Antenna

BSU .....Integrated, LHCP (left-hand circular polarization) 18 dBi

SU .....Integrated, LHCP 21 dBi

## Receiver Sensitivity

Burst Rate	Threshold
60 Mbps	-77 dBm
40 Mbps	-81 dBm
30 Mbps	-86 dBm
20 Mbps	-89 dBm

## Maximum Distance Between Base Station and Subscriber Unit

BURST-RATE	CLOS <sup>1</sup>	NLOS <sup>2</sup>
60 Mbps	3 miles/5 km	1.2 miles/2 km
40 Mbps	4 miles/6.6 km	2 miles/3.5 km
30 Mbps	5 miles/8.3 km	2.4 Miles/4 km
20 Mbps	6 miles/10 km	3 miles/5 km

<sup>1</sup>Clear-Line-of-Sight distance is calculated for 99.995% availability assuming no obstructions in the first Fresnel Zone.

<sup>2</sup>Near-Line-of-Sight distance is for a typical installation with moderate multipath/shadowing due to terrain and structures.

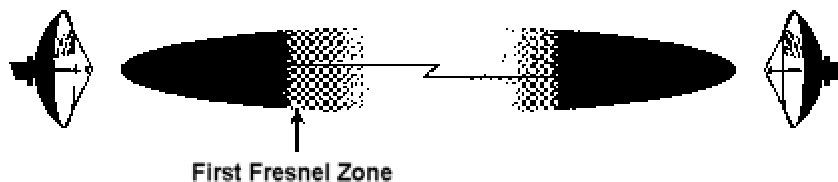

Figure 29. Fresnel Zones

The Fresnel Zone refers to the radio beam. The radio signal's path length and frequency determine the Fresnel Zone's width and shape. When a large part of the Fresnel Zone is blocked, some of the radio signal's energy is lost.

## System

Operating Frequency Range.....	5725-5825 MHz
Radio Access Method .....	TDMA
Duplexing .....	Time Division Duplex (TDD)
Integrated Antenna (BSU).....	19 dBi (60° Azimuth. X 6° Elevation) LHCP
Integrated Antenna (SU).....	20 dBi (10° Azimuth. X 10° Elevation) LHCP
Max Subscriber Units/BSU.....	1,023
Frequency Channels .....	4 non-overlapping, 5 and 6 overlapping available
Regulatory Compliance .....	FCC Part 15-247, IC RSS21 0

## Standards Compliance and Interfaces

Ethernet Interface.....	10/100 Base-T
Ethernet Connector .....	RJ-45 female
BSU indoor-outdoor cable .....	Circular plastic connectors with Category 5 cable
SU indoor-outdoor cable .....	RJ-45 (outdoor) and DIN (indoor) over Cat 5 (UV) cable
Standards Compliance .....	IEEE 802.1d Bridging Mode (a subset of the 802.d standard) IEEE 802.1q VLAN

## Configuration and Management

### BSU Configuration

Configuration .....	via Ethernet or Wireless Manager (future release)
SNMP .....	AgentMIB II (future release)
Security .....	Authentication, IP/MAC Filtering, passwords
Software Upgrades.....	Downloadable Base Station reprogramming

### SU Configuration

Configuration .....	Automatic
Security .....	Authentication, IP/MAC Filtering
Software Upgrades.....	Over-the-air Subscriber Unit programming

## **Power/Environment Safety**

### **Electrical**

Base Station Unit.....	-36 to -60 Volts DC, 1.25 Amps
Base Station Unit Power Brick.....	100-240 Volts AC
Base Station Unit Power Block .....	48 Volts DC
Subscriber Unit.....	18 to 28 Volts DC, 0.8 Amps
Subscriber Unit Power Brick.....	115 or 100-240 Volts AC

### **Operational Temperature**

Indoor.....	0° to 55° C
Outdoor.....	-33° to 65° C

### **Humidity**

Indoor.....	95% non-condensing
Outdoor.....	5% to 100%, condensing
EIVIC.....	FCC Class B
Safety .....	UL-1950
Environmental Compliance .....	ETS 300 019

## **Physical Dimension**

### **Base Station (Outdoor Unit)**

Size (WxHxD) .....	10.2 x 24 x 6.6 inches/25.9 x 61 x 16.8 cm
Weight .....	20 lbs/9 kg

### **Base Station Power Block (Indoor Unit, for up to 6 Base Stations)**

Size (WxHxD) .....	17.2 x 3.5 x 8.25 inches/43.7 x 8.9 x 21 cm
Weight .....	5 lbs/2.3 kg

### **Base Station Power Brick (Indoor Unit, for 1 Base Station)**

Size (WxHxD) .....	37.4 x 70.9 x 24.8 inch/95 x 180 x 63 cm
Weight .....	1.5 lbs/0.7 kg

### **Subscriber Unit (Outdoor Unit)**

Size (WxHxD) ..... 10.5 x 10.5 x 6.8 inches/26.5 x 26.5 x 17.4 cm  
Weight ..... 10 lbs/4.5 kg

### **Subscriber Unit Power Brick (Indoor Unit)**

Size (SxHxD) ..... 36 x 5.1 x 2.6 inch/92 x 130 x 67 cm  
Weight ..... 2.7 lbs/1.2 kg

### **Installation Details**

Base Station Unit (outdoor unit)..... Pole mounting, 1.5-4.5" diameter  
Subscriber Unit (outdoor unit) ..... Pole mounting, 1.25-1.75" diameter

### **Optional Accessories**

#### **Base Station Unit**

Connector kit ..... Part # ACC-5300

#### **Subscriber Unit**

Wall mounting kit ..... Part # ACC-40100  
(contact factory for details)  
Connector kit ..... Part # ACC-5200

## Appendix D. Constructing Power and Ethernet Cables

### Subscriber Unit Power and Ethernet Cable

Perform the following steps to construct a Subscriber Unit power and Ethernet cable of the desired length.

**CAUTION** For best results this cable should be constructed by professional cable manufacturer or by experienced personnel with proper tools. Contact Proxim Customer Service or Sales for recommendations for a manufacturer near your vicinity.

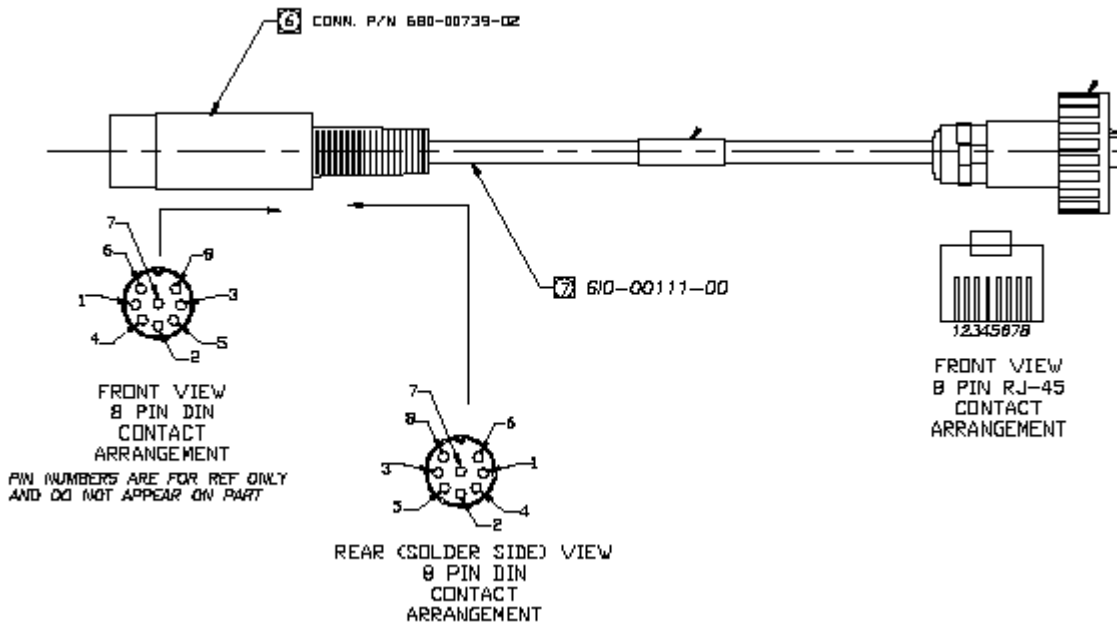

Figure 30. 8-Pin DIN and RJ45 Contact Arrangements

Perform the following steps to construct an interface cable of the desired length.

**WARNING!** Interface cable length should not exceed 75 m.

### Required Materials

The following is a list of the materials required to assemble an interface cable.

- Cat 5 UV cable (75 meters maximum).
- One each 8-pin DIN male connector with cover (solder type) or one each 8-position DIN male connector (crimp type).
- One each Woodhead weatherproof RJ45 connector.

## Assembling the 8-Pin DIN Connector

To assemble the 8-pin DIN connector:

1. Slide the jacket of the 8-pin DIN connector over one end of the Cat 5 UV cable.
2. Prepare the Cat 5 cable ends by removing 0.75" of the main jacket. Do not cut the twisted pair wires.
3. Remove 0.06" of insulation from the end of each wire in each twisted pair.
4. Solder each wire prepared in step 3 to the appropriate cup on the DIN connector. Refer to the following table for information.

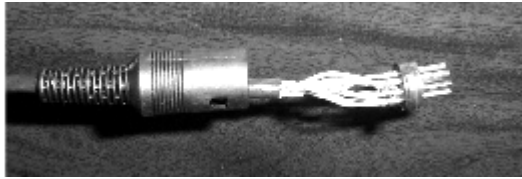

**Figure 31. Soldered Wires on 8-Pin DIN Connector**

Interface Cable Pin Assignments			
DIN Pin	Color	Signal	RJ45 Plug Pin
⑧ 2 7	Orange	+24 VDC	4
	Orange/White	- 24 VDC	5
⑧ 6 8	Brown	+24 VDC	7
	Brown/White	- 24 VDC	8
⑧ 5 3	Green	Tx+	1
	Green/White	Tx-	2
⑧ 1 4	Violet	Tx+	3
	Violet/White	Rx-	6

5. Assemble the metal shell over the DIN connector; make sure the DIN connector fits into the slots of the metal shell.



**Figure 32. Metal Shell Placed Over 8-Pin DIN Connector**



- Using small pliers, crimp the metal strain relief over the Cat 5 cable. Do not cut into the cable. Slide the jacket over the completed assembly.



**Figure 33. Jacket Placed Over 8-Pin DIN Connector**

## Assembling the RJ45 (Woodhead) Weatherproof Connector

---

**CAUTION** For best results this cable should be constructed by professional cable manufacturer or by experienced personnel with proper tools. Contact Proxim Customer Service or Sales for recommendations for a manufacturer in your vicinity.

---

To assemble the RJ45 (Woodhead) connector:

- Slide the threaded Woodhead cover over the bare end of the Cat 5 cable.
- Slide the body of the Woodhead connector over the bare end of the Cat 5 cable.
- Slide a rubber "O" ring over the ridge of the Woodhead connector's body.
- Remove 0.5" of jacket from the Cat 5 cable. Do not cut the wires of the twisted pairs.



**Figure 34. Cat 5 Cable with Insulation Removed**

- Insert the ends of the twisted pairs into the RJ45 connector positioning wire color code (see the table on the previous page).
- Crimp the wires into the RJ45 connector using an RJ45 crimp tool.

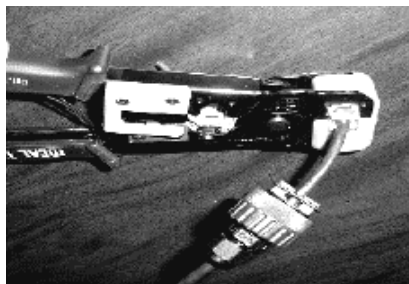

**Figure 35. Wires Crimped into RJ45 Connector**

- Slide the threaded Woodhead cover over the completed assembly and loosely tighten it down to the cable.



**Figure 36. Woodhead Cover Placed Over RJ45 Connector**

- When connecting the cable to an SU, insert the RJ-45 connector into the SU's Power and Ethernet port until the locking tang clicks, slide the Woodhead body over the RJ-45 connector until it is seated, tighten the coupling nut to seal the connector to the housing, and tighten the gland to seal the assembly to the cable.

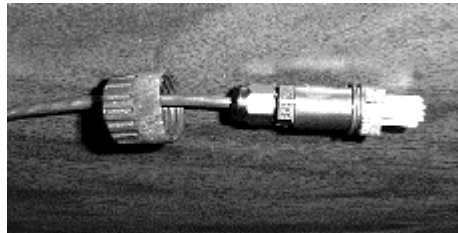

**Figure 37. End Nut Seated on RJ45 Connector**

## **BSU Power and Ethernet Cable**

This section describes how to construct a Power and Ethernet cable for a BSU. This cable has the following connectors:

- 18-pin Positronic connector
- 8-pin AMP connector

### **Installing an 18-Pin Positronic Connector**

Perform the steps following the figure to install an 18-pin positronic connector on the cable.

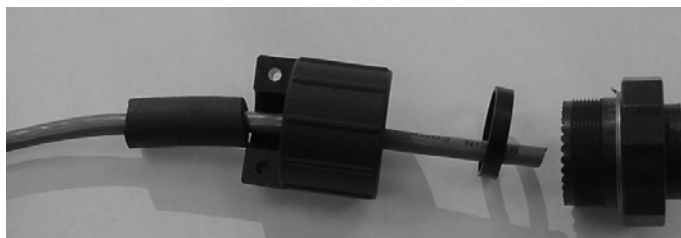

**Figure 38. 18-Pin Positronic Connector**

**Tsunami Multipoint Version 1.3 Installation Guide**

1. Cut 750-00891-00 tubing or Proxim approved equivalent to 1.25" +/- 0.1".
2. Using silicone spray or equivalent lubricant, spray the end of the wire, then slide the tubing onto the wire, approximately 4" out of the way.
3. Slide the backshell with the ½" (inside diameter) rubber cable seal onto the wire.
4. Crimp the connector pins onto the individual wires using a Positronic crimping tool 9507 (crimping frame) and 9502-20 (die).
5. Insert the 1.9" (outside diameter) 1/8" wide plastic ring inside the rear of the connector.
6. Insert the crimped pin/wire assemblies in the appropriate holes in the rear of the connector.
7. Attach the backshell to the connector by threading it clockwise onto the connector.

---

**Note:** You need a FR19MF1822K0 connector plug (no pins required, housing only) to get a better grip on the connector. A good grip is required to sufficiently torque the backshell to provide a good seal. When torquing the backshell, make sure the CAT5 cable can still rotate freely inside the backshell so it does not get broken.

---

8. Using silicone spray, slide the tubing into the cable seal inside the backshell until it is flush with the end of the connector.
9. Install the backshell clamp over the tubing and wire.

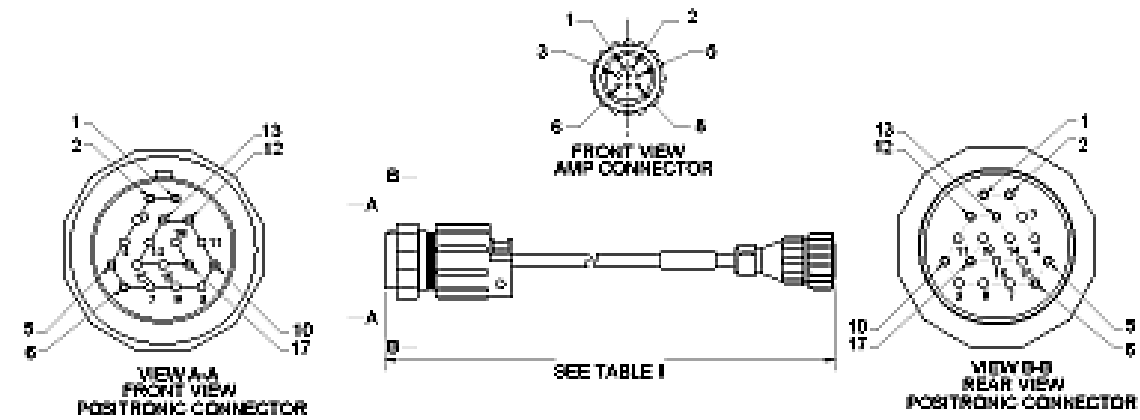

Pin Pos	Color	Signal	AMP Pin
17	orange	48VDC+	1
10	white/orange	48VDC-	2
6	brown	48VDC+	3
5	white/brown	48VDC-	4
12	violet	Rx+	7
13	white/violet	Rx-	8
1	green	Tx+	5
2	white/green	Tx-	6

Dash No	Length
-01	25m-.1m
-02	50m-.1m
-03	75m-.1m

**Figure 39. BSU Power and Ethernet Cable Connectors**

## About Crimping

Loose piece contacts are designed to be crimped with crimp tooling (hand tools, die assemblies, or crimping heads), but can be done with normal hand tools. The applicable crimp tooling for the contacts is described later in this section. Read the documentation included with the crimp tooling for the proper crimping procedure.

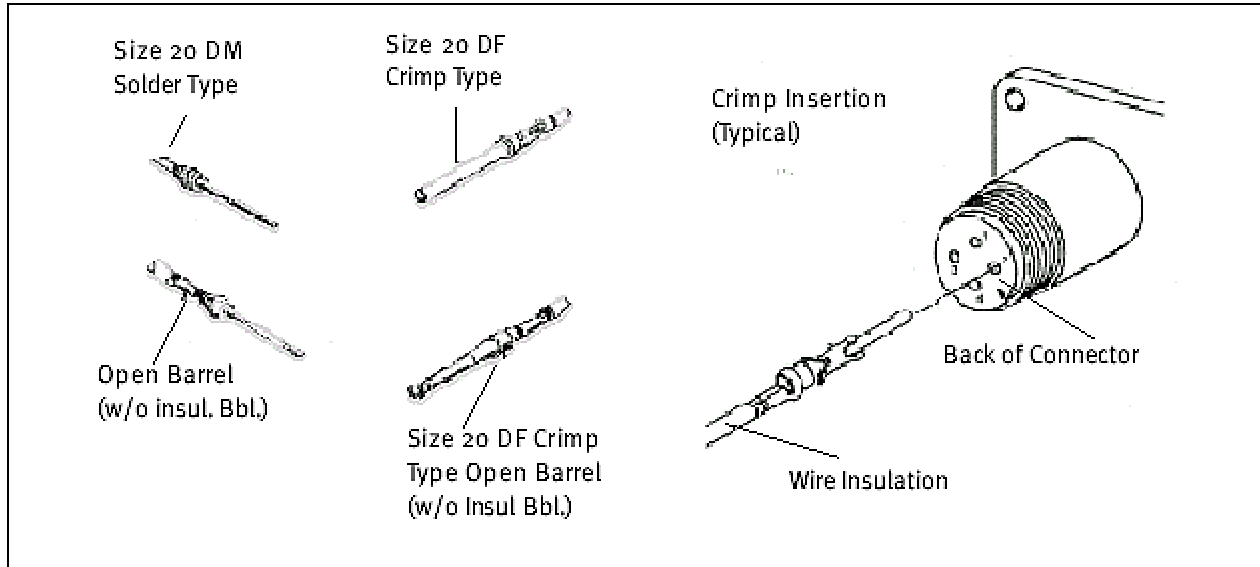

Figure 40. Crimping Styles and Insertion

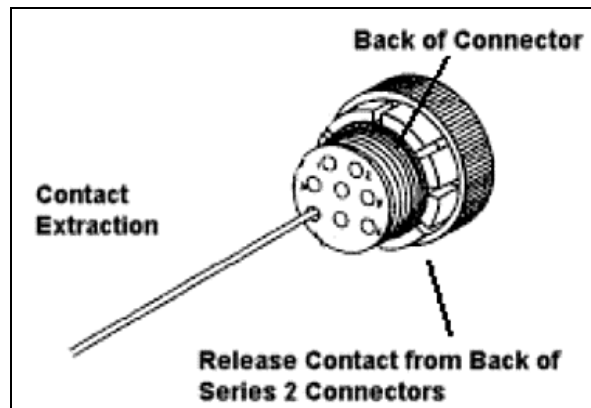

Figure 41. Indoor Portion of Power and Ethernet Cable

## Wire Size and Preparation

Contacts are available for the wire sizes specified. Prepare the wire for crimping by stripping the insulation. DO NOT nick, scrape, or cut the stranded or solid wire conductor while stripping the insulation.

---

**Note:** When using twisted pair cable, cut one wire shorter than the other.

---

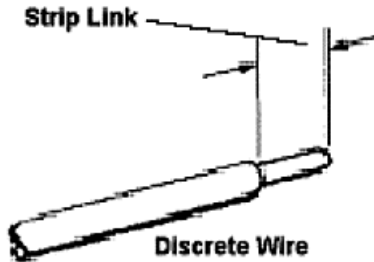

**Figure 42. Wire Preparation**

## Tooling

AMP hand crimping tools and applicators are available for applying crimp type contacts. Also, insertion and extraction tools assist in assembly and repair. See the documentation included with the tool for more information.

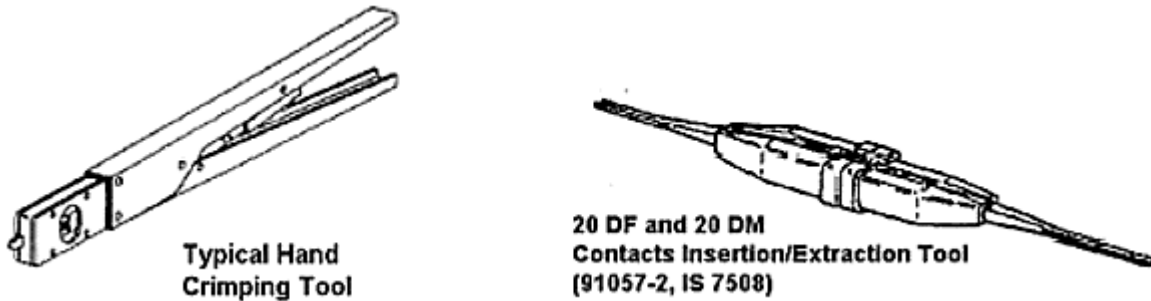

**Figure 43. BSU Cable Construction Tools**

## **Installing the AMP CPC Connector with Shield and Strain Relief**

The indoor end of the BSU Power and Ethernet cable uses an 8-pin circular plastic AMP connector with crimp contacts. The connector is a reverse sex plug with male connector pins. The plug provided is not weather tight and is meant for indoor use only. The connector uses a shield to cover the pin end of the wires and has a strain relief clamp with two self-tapping screws to clamp the cable sheath to the connector.



**Figure 44. 8-Pin AMP Connector**

To install the AMP CPC connector on the BSU Power and Ethernet cable:

1. Install the shield on the cable before removing the cable jacket. Slide the shield onto the cable so that the threaded, large-diameter end faces the end of the cable.
2. Crimp the contacts to the wires according to the documentation included with the crimp tooling. Pins are size 20 DM and the wire strip length is 0.100”.
3. Insert the contacts into the housing one at a time by gripping the insulation of the wire directly behind the contact and aligning the contact with the back of the desired contact cavity.
4. Insert each contact straight into the cavity until it bottoms, then pull back lightly on the wire to be sure the contact is locked in place.
5. Thread the shield onto the connector and tighten the shield finger-tight.
6. Screw in the strain relief over the end of the cable using the two supplied Phillips head screws.

---

## **Appendix E. Lightning Protection Recommendations**

This appendix describes Proxim Lightning Protection Recommendations for:

- Tsunami Multipoint Base Station Unit 40400-25/-65
- Tsunami Multipoint Subscriber Unit 40100-251/-252/-651/-652

### **Introduction**

#### **What is Lightning Protection?**

All outdoor electronic equipment is susceptible to lightning damage. Proper grounding to national and local codes is instrumental in providing human safety. Lightning Protection is used when a customer wants to maximize the reliability of the electronic system by diverting the excess energy that can be induced on any transmission lines (data, power) through a series of surge protection devices. The energy is dissipated through heat and also diverted to ground.

#### **What Lightning Protection is Built Into the Tsunami Equipment?**

All Tsunami Multipoint and QuickBridge equipment have built-in lightning protection on both the power supply lines and the Ethernet lines. There are TVS diodes that provide protection to IEC 61000-4-5. Proxim Corporation uses “well-design” practices in incorporating these devices in the Tsunami Multipoint and QuickBridge products.

#### **Why is Additional Protection Recommended?**

Lightning, even with the built-in protection, can still damage outdoor Tsunami equipment. This can occur for any number of reasons, such as an improperly grounded installation or if the amount of transient energy from nearby lightning exceeds what the devices can handle.

If a Tsunami unit fails due to damage from lightning, the link is out-of-service until the unit is replaced or repaired. An external, revertive protection device can provide a higher level of protection, and greater probability of surviving lightning transients without damage to the Tsunami equipment. If damage does occur, most likely it is to the lightning protection devices and not the Tsunami equipment. Remember, even with external lightning protection, damage can still occur to the Tsunami outdoor unit.

## Recommendation

Proxim recommends the following for its Tsunami Multipoint products:

Proxim Product	Installation Requirement		
	Industrial	Commercial	SOHO
Tsunami Multipoint Base Station Unit (BSU) 20/60 Mbps Models	(1)	(1)	(1) or (2) (up to 50 meters)
Tsunami Multipoint Subscriber Unit (SU) 20/40/60 Mbps Models	(1)	(1) or (2) (up to 50 meters)	(1) or (2) (up to 50 meters)
(1) PolyPhaser 101-1218W-A.1 CAT5 Data Protector  PolyPhaser Corporation 2225 Park Place, Minden, Nevada 89423		(2) Transtector 1101-TSU Surge Suppressor  Transtector Systems, Inc. 10701 Airport Drive Hayden Lake, ID 83835	

### PolyPhaser CAT5 Data Protector

This is a heavy-duty aluminum, weather-tight enclosure for outdoor use that serves to protect the Tsunami outdoor unit, as well as the indoor power adapter and connected line equipment inside the roof penetration. This product can be used for all CAT5 cable lengths up to 100 meters from the outdoor Tsunami unit to the indoor power adapter.

The Polyphaser Data Protector uses Cascade Technology. This is a multi-stage technology that is superior to single stage because of high surge current capacity and fast response time. The unit is designed to fit in-line onto the outdoor Cat 5 cable, using two weatherized plug openings for the cable to enter and exit. The existing cable is cut, dressed, and reconnected onto two sets of 8 screw terminals inside the Data Protector.

**List Price:** \$209/ea.

**Delivery:** Available from authorized Proxim reseller or installer off-the-shelf.



## Transtector Systems Surge Suppressor

This outdoor-use, molded plastic, weather-tight enclosure is a surge suppressor designed to protect the Tsunami Multipoint SU and the QuickBridge unit from lightning damage. This product can be used for CAT5 cable lengths up to 50 meters from the outdoor Tsunami unit to indoor power adapter.

The 1101-TSU uses silicon avalanche suppression diodes (SASD) to provide lower voltage protection level (VPL). This technology provides a superior protection level over traditional gas tube type devices. The unit is designed to fit onto a CAT5 cable in a pass-through configuration. The input and output connections can be made at two sets of 8-screw terminals, or two 8-pin DIN style connectors.

This arrangement allows the installation of the connectorized Cat 5 cable directly into the Surge Suppressor, or with a cut cable.

**List Price:** \$99/ea.

**Delivery:** Available from authorized Proxim reseller or installer off-the-shelf.

## Physical Considerations

### How are the Lightning Protection Units Connected to the CAT5 Cable?

The lightning protection units recommended are designed to be installed in-line onto the Cat 5 cable that connectors the outdoor (RF) Tsunami unit (Base Station, Subscriber Unit, QuickBridge) and the indoor power adapter.

The lightning protection device has a **Surge** (cable-facing) side, and an Equipment (equipment-facing) side. The Equipment side faces the outdoor Tsunami unit or the indoor power adapter. The Surge side faces the long length of cable; when installing two lightning protection units, each unit's Surge side face one another.

See Pin-out information for each unit in "Lightning Protection Specifications" on page 73 for connecting the cable to the protection device.

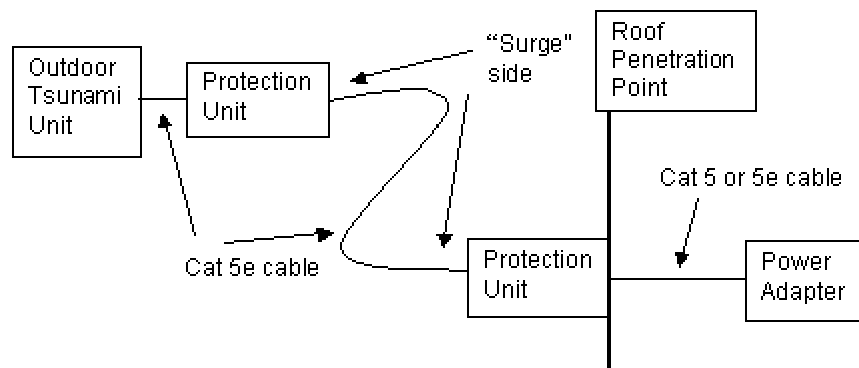

## Where Should the Protection Units be Located?

At least one unit should be installed near every outdoor Tsunami unit. General guidelines are:

- Locate protection unit as close to the outdoor Tsunami unit as possible, where the lightning protection unit can be securely mounted to a flat surface **and** grounded properly. Ideally, this should be no further than five feet away from the outdoor unit.
- Locate one unit at the roof penetration point, outside, so that the cable immediately enters the building after the protection unit. This unit is optional if the distance from the first unit to the roof penetration point is relatively short (under 15 feet).

Installing two units provides the maximum protection against lightning damage to the outdoor Tsunami unit and the indoor power adapter, especially if the CAT5 cable length is greater than 15 meters.

## Lightning Protection Specifications

### PolyPhaser 101-1218W-A.1 Data Protector

Surge: BellCore 1089 10/100 $\mu$ sec, 100A

Temperature: -40°C to +65°C storage/operating +50°C

#### Maximum Characteristics Data:

Turn-on: +7.0 VDC  $\pm$  10%  
Resistance: 1 ohm  
Capacitance: 15 pf Line to Ground, 30 pf Line to Line  
Data Range: Up to 100Mbps (100BT)

#### Maximum Characteristics DC:

Turn-on:  $\pm$  68 VDC  $\pm$  10%  
Resistance: 0.02 ohm  
User Current: 2A max.  
Size L x W x T: 6.53" x 2.77" x 1.25"

**Pinout and Wiring Specifications:**

Surge Side	Equipment Side	Application	Wire Color
Vdc in	VDC out	48Vdc	White/Orange
RTN in	RTN out	Ground	Orange
Vdc in	VDC out	48Vdc	White/Brown
RTN in	RTN out	Ground	Brown
Tx+ in	Tx+ out	Tx +	Green
Tx- in	Tx- out	Tx -	White/Green
Rx+ in	Rx+ out	Rx +	Violet
Rx- in	Rx- out	Rx -	White/Violet
GND	GND	Shield, if req.	N/A

---

**Note:** VDC in (out) and RTN in (out) pinouts are based upon applying a negative or positive 48 FDC to the VDC terminal and applying the **dc ground to RTN**.

---

For additional information, go to [www.polyphaser.com](http://www.polyphaser.com).

**Contact Information:**

Polyphaser Corporation (702) 782-2511  
 2225 Park Place (702) 782-4476 (fax)  
 P. O. Box 9000  
 Minden, Nevada 89424

**Transtector Systems ALPU-TSU Surge Suppressor**

Surge: ..... IEEE 10/1000 Long Wave, 150 A peak  
 Temperature: ..... -40°C to +80°C operating and storage

**Ethernet Characteristics:**

Transfer Rate: ..... CAT5  
 Maximum Continuous Operating Voltage: ..... 20 VDC  
 Protection Mode: ..... Line to Line, Line to Ground  
 Response Time (max): ..... 5 nanoseconds  
 Standby Power (max): ..... <0.5 Watt  
 Peak Power: ..... 5000 Watts

**DC Characteristics:**

Service Voltage: ..... 20 VDC  
 Maximum Continuous Operating Voltage: ..... 80 VDC  
 Response Time (max): ..... 5 nanoseconds  
 Standby Power (max): ..... <0.5 Watts  
 Peak Power: ..... 20,000 Watts  
 Protection Mode: ..... Line to Line  
 Size: ..... L x W x T: 6.13" x 4.5" x 2.5"

**Pinout and Wiring Specifications:**

<b>Surge Side</b>	<b>Equipment Side</b>	<b>Application</b>	<b>Wire Color</b>
VDC in	VDC out	48 VDC	White/Orange
RTN in	RTN out	Ground	Orange
VDC in	VDC out	48 VDC	White/Brown
RTN in	RTN out	Ground	Brown
Tx+ in	Tx+ out	Tx +	Green
Tx- in	Tx- out	Tx -	White/Green
Rx+ in	Rx+ out	Rx +	Violet
Rx- in	Rx- out	Rx -	White/Violet
GND	GND	Shield, if req.	N/A

For additional information, go to [www.transtector.com](http://www.transtector.com).

**Contact information:**

Transtector Systems  
OEM Division  
10701 Airport Drive  
Hayden Lake, ID 83858

(208) 762-6069  
(208) 752-6155 (fax)  
[oem@transtector.com](mailto:oem@transtector.com)

---

## Appendix F. Technical Support and Training

If you are having a problem using a Tsunami Multipoint and cannot resolve it with the information in "Appendix A. Troubleshooting" in the *Tsunami Multipoint Version 1.3 Reference Manual*, gather the following information and contact Proxim Technical Support:

- What kind of network are you using?
- What were you doing when the error occurred?
- What error message did you see?
- Can you reproduce the problem?

You can reach Proxim Technical Support by phone, fax, e-mail, or mail:

Tel: 1-408-542-5390 (International)  
Fax: 1-408-731-3673  
Web: <http://www.proxim.com/>  
E-mail: [support@wmux.com](mailto:support@wmux.com)

FTP: <ftp.wmux.com> (to download software)

Proxim Corporation

Attn: Technical Support  
510 DeGuigne Drive  
Sunnyvale, CA 94085

In addition, Proxim offers technical training courses across the United States throughout the year that are designed to teach customers how to maximize the benefits of Proxim products. These classes are taught by experienced Proxim Systems Engineers and have a technical focus. For class and registration information, visit this Web site at <http://www.wmux.com>.

Be sure to obtain an RMA number before sending any equipment to Proxim for repair.