



## TEST REPORT

**Report Number: 30449042**  
**Project Number: 3044904**  
**October 6, 2003**

**Testing performed on the**  
**Tsunami Multipoint Base Station Unit**  
**FCC ID: HZB-S58-B60**  
**to**

**FCC Part 15, Subpart C**

**for**  
**Proxim Corporation**

Test Performed by:  
Intertek Testing Services  
1365 Adams Court  
Menlo Park, CA 94025

Test Authorized by:  
Proxim Corporation  
935 Stewart Drive  
Sunnyvale, California 94085

Prepared by: David Chernomordik  
David Chernomordik

Date: 10/06/03

Reviewed by: Ollie Moyrong  
Ollie Moyrong

Date: 10/08/03

*This report is for the exclusive use of Intertek's Client and is provided pursuant to the agreement between Intertek and its Client. Intertek's responsibility and liability are limited to the terms and conditions of the agreement. Intertek assumes no liability to any party, other than to the Client in accordance with the agreement, for any loss, expense or damage occasioned by the use of this report. Only the Client is authorized to copy or distribute this report and then only in its entirety. Any use of the Intertek name or one of its marks for the sale or advertisement of the tested material, product or service must first be approved in writing by Intertek. The observations and test results in this report are relevant only to the sample tested. This report by itself does not imply that the material, product, or service is or has ever been under an Intertek certification program. This report must not be used to claim product endorsement by A2LA, NIST nor any other agency of the U.S. Government.*

**TABLE OF CONTENTS**

**1.0 Summary of Tests ..... 3**

**2.0 General Description ..... 4**

    2.1 Product Description ..... 4

    2.2 Related Submittal(s) Grants ..... 7

    2.3 Test Methodology ..... 7

    2.4 Test Facility ..... 7

**3.0 System Test Configuration ..... 8**

    3.1 Support Equipment and description ..... 8

    3.2 Block Diagram of Test Setup ..... 8

    3.3 Justification ..... 9

    3.4 Software Exercise Program ..... 9

    3.5 Mode of operation during test ..... 9

    3.6 Modifications required for Compliance ..... 9

    3.7 Additions, deviations and exclusions from standards ..... 9

**4.0 Measurement Results ..... 10**

    4.1 Conducted Output Power at Antenna Terminals ..... 10

    4.2 6 dB RF Bandwidth ..... 11

    4.4 Out-of-Band Conducted Emissions ..... 24

    4.6 Transmitter Radiated Emissions ..... 25

    4.7 Radiated Emissions from Digital Section of Transceiver ..... 30

    4.8 Radiated Emissions from Receiver Section of Transceiver (L.O. Radiation) ..... 33

    4.9 AC Line Conducted Emission ..... 34

**5.0 List of Test Equipment ..... 39**

**6.0 Document History ..... 40**

**Appendix A – Out-of-band conducted emissions plots ..... 41**

## 1.0 Summary of Tests

FCC ID: HZB-S58-B60

TEST	REFERENCE	RESULTS
Output power	15.247(b)	Complies
6 dB Bandwidth	15.247(a)(2)	Complies
Power Density	15.247(d)	Complies
Out-of-band Antenna Conducted Emission	15.247(c)	Complies
Out-of-band Radiated Emission (except emissions in restricted bands)	15.247(c)	Not Applicable. The EUT passed out-of-band antenna conducted emission
Radiated Emission in Restricted Bands	15.209, 15.205	Complies
AC Line-conducted Emission	15.207	Complies
Radiated Emission from Digital Part	15.109	Complies
Radiated Emission from Receiver L.O.	15.109	Not Applicable. The operating frequency is above 960 MHz
RF Exposure Requirement	2.1091	Complies, see exhibit "RF Exposure"
Antenna Requirement	15.203	Not Applicable; professional installation is required

A pre-production version of the EUT was received on June 24, 2003 in good operating condition. As declared by the Applicant, it is identical to the production units.

Date of Test: June 25, 2003 – July 17, 2003

## 2.0 General Description

### 2.1 Product Description

The 40400-xxx (FCC ID: HZB-S58-B60) is a product family that includes the following models:

Model	Description
40400-35	Tsunami Multipoint 30MB Base Station Unit
40400-65	Tsunami Multipoint 60MB Base Station Unit
40400-35R	Tsunami Multipoint 30MB A.I.R. Base Station Unit
40400-65R	Tsunami Multipoint 60MB A.I.R. Base Station Unit
40400-35C	Tsunami Multipoint 30MB Base Station Unit with External Antenna Connector
40400-65C	Tsunami Multipoint 60MB Base Station Unit with External Antenna Connector

The HZB-S58-B60 platform consists of two major components: an outdoor unit (ODU) and an indoor power adapter (IPA). It supports four modulation modes: QPSK  $\frac{1}{2}$ , QPSK  $\frac{3}{4}$ , 8QAM and 16QAM. Corresponding to each different modulation mode, the product is capable of data communication with data rate of 20Mbps, 30Mbps, 40Mbps and 60Mbps. The table above lists all product models Proxim currently markets.

With regards to antenna connection, the product family can be divided into two groups, base station with integrated antenna (integrated BSU) and base station using external antenna (connectorized BSU).

An integrated BSU has an integrated antenna with up to five arrays of antenna patches, one for transmit and one or four for receive. The internal PCB design for all the models is identical, except for the component loading options between the regular (40400-35/65) version and the A.I.R. version (40400-35R/65R). In the A.I.R. version, all four receivers are loaded to receive signals via different antenna arrays, thereby allowing the system to further process the signal using a noise cancellation algorithm. On the other hand, the regular version only has one receiver loaded. Testing was done on the fully loaded option that yields the worst-case emission.

A connectorized BSU is identical to the regular version integrated BSU internally, except the connectorized BSU has a circulator/isolator hardware in between the RF output of the RF board and the radio antenna port. See the diagram below.

Base Station Unit with Integrated Antenna

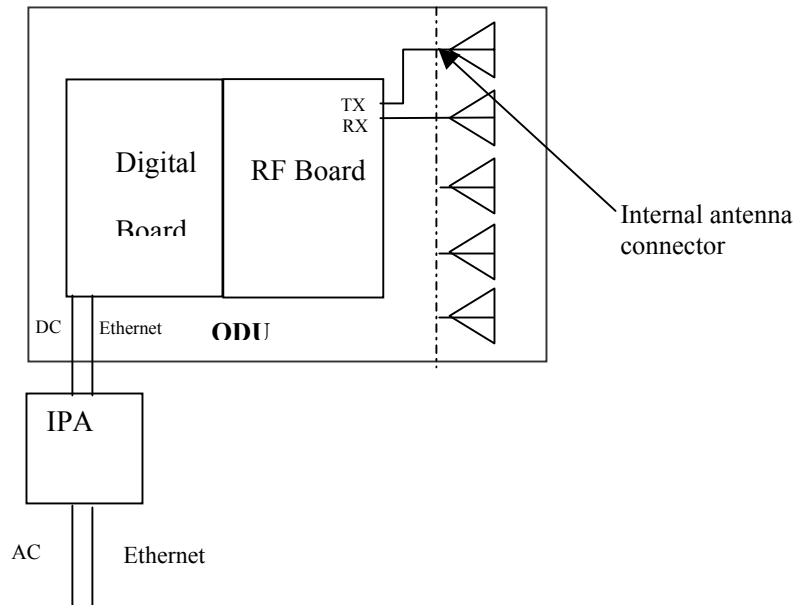

Connectorized Base Station Unit

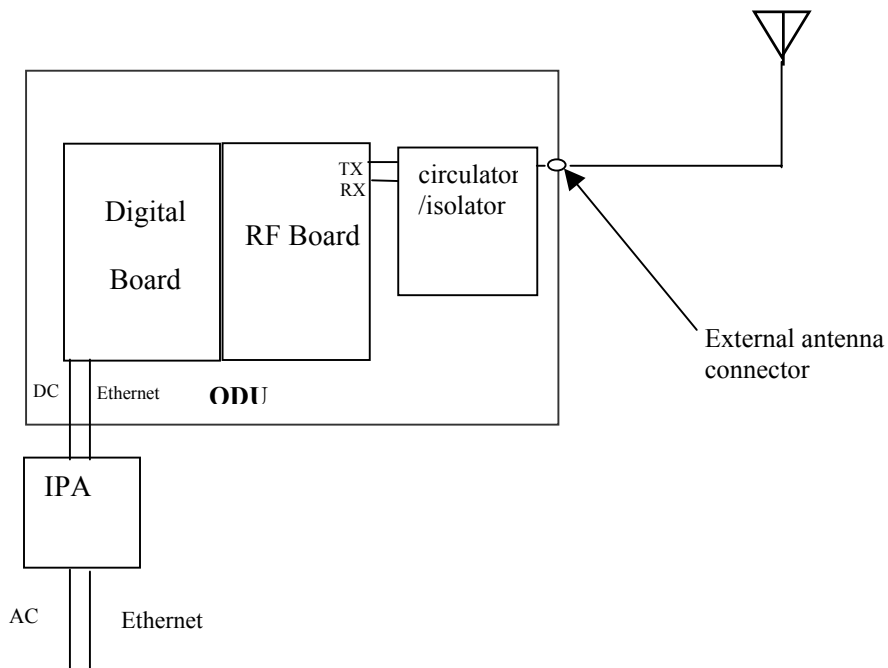

**Overview of the Model: 40100-xxx, FCC ID: HZB-S58-B60**

<b>Applicant name &amp; address</b>	Proxim Corporation 935 Stewart Drive, Sunnyvale, CA 94085 USA
<b>Manufacturer</b>	Proxim Corporation
<b>FCC Identifier</b>	HZB-S58-S60
<b>Use of Product</b>	Fixed Wireless Ethernet Access
<b>Type of Transmission</b>	TDD
<b>Type of Modulation</b>	QAM16, QPSK 3/4, QPSK 1/2
<b>Rated RF Output</b>	20 dBm (peak)
<b>Frequency Range</b>	5740 – 5810 MHz
<b>Number of Channel(s)</b>	6 channels maximum
<b>Antenna Requirement</b>	The EUT requires professional installation.

As declared by the Applicant, the following antennas may be used with the Connectorized BSU:

Connectorized BSU Antenna List					
Antenna Type	Manufacturer	Model Number	Mid-band Gain (dBi)	Notes	Used for testing
Omni	Telex	5830AN	7.5	Vertical	<b>X</b>
	MTI	MT-482009/N	9		
	MTI	MT-483003/N	12		<b>X</b>
Flat Panel	European Antennas	SA17-55V/450	17	Vertical, 60 x 7 degree sector antenna	
	Radio Waves	SEC-5V/H-90-17	17	Linear, 90 x 6 degree sector antenna	
	Radio Waves	SEC-5V/H-60-18	18	Linear, 60 x 6 degree sector antenna	<b>X</b>

Therefore, the antennas marked with "X" have been chosen for testing.

## 2.2 Related Submittal(s) Grants

None.

## 2.3 Test Methodology

Both conducted and radiated emissions measurements were performed according to the procedures in ANSI C63.4 (1992). Radiated tests were performed at an antenna to EUT distance of 3 meters, unless stated otherwise in the "**Data Sheet**" of this Application. All other measurements were made in accordance with the procedures in parts 2 and 15 of CFR 47.

## 2.4 Test Facility

The open area test site and conducted measurement facility used to collect the radiated data is site 1 (10-m semi-anechoic chamber). This test facility and site measurement data have been fully placed on file with the FCC and A2LA accredited.

**3.0 System Test Configuration**

3.1 Support Equipment and description

Laptop computer: Hewlett Packard Omnibook 4150

3.2 Block Diagram of Test Setup

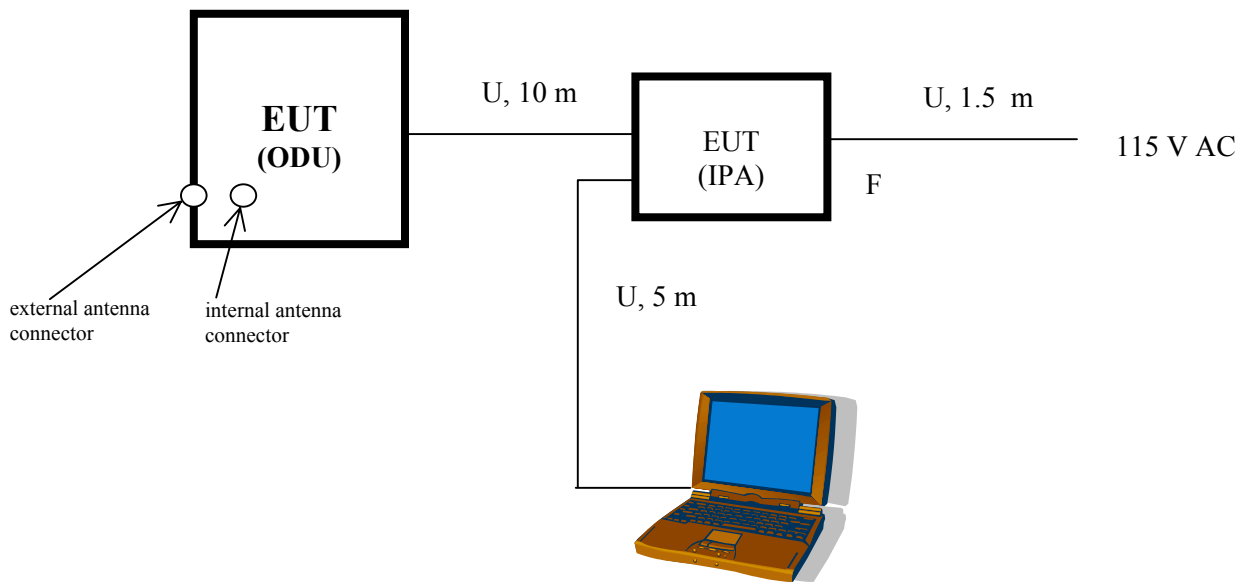

<b>S</b> = Shielded	<b>F</b> = With Ferrite
<b>U</b> = Unshielded	<b>m</b> = Meter



### 3.3 Justification

For emission testing, the Equipment Under Test (EUT) was configured for testing in a typical fashion (as a customer would normally use it). During testing, all cables were manipulated to produce worst-case emissions.

For radiated emission measurements, the EUT is attached to a cardboard box (if necessary) and placed on the wooden turntable. If the EUT attaches to peripherals, they are connected and operational (as typical as possible). The EUT is wired to transmit full power.

The signal is maximized through rotation and placement in the three orthogonal axes. The antenna height and polarization are varied during the search for maximum signal level. The antenna height is varied from 1 to 4 meters.

Radiated emissions are taken at three meters unless the signal level is too low for measurement at that distance. If necessary, a pre-amplifier is used and/or the test is conducted at a closer distance. All readings are extrapolated back to the equivalent three-meter reading using inverse scaling with distance.

Care was taken to ensure proper power supply voltages during testing.

### 3.4 Software Exercise Program

The EUT exercise program used during radiated and conducted testing was designed to exercise the various system components in a manner similar to a typical use. For emissions testing, the units were setup to transmit continuously to simplify the measurement methodology.

### 3.5 Mode of operation during test

Transmitting signal on different channels with different types of modulation.

### 3.6 Modifications required for Compliance

Intertek installed no modifications during compliance testing in order to bring the product into compliance.

### 3.7 Additions, deviations and exclusions from standards

No additions, deviations or exclusion have been made from standard.

#### 4.0 Measurement Results

##### 4.1 Conducted Output Power at Antenna Terminals FCC Rule: 15.247(b)

###### Requirements

For systems operating in the 5725 - 5850 MHz band, maximum allowed transmitter output is 1 Watt or 30 dBm (for antenna gain up to 6 dBi).

###### Procedure

The antenna port of the EUT was connected to the input of a peak power meter. Power was read directly from the power meter.

###### Test Results

<b>Frequency MHz</b>	<b>Modulation</b>	<b>Output Peak Power</b> (measured from integrated BSU RF output) <b>dBm</b>	<b>Output Peak Power</b> (measured from connectorized BSU antenna connector) <b>dBm</b>
5740	QAM16	19.0	19.9
	QPSK 3/4	17.1	18.0
	QPSK 1/2	17.3	17.9
5775	QAM16	18.6	20.3
	QPSK 3/4	17.2	18.7
	QPSK 1/2	17.0	18.9
5810	QAM16	18.7	20.3
	QPSK 3/4	17.2	18.1
	QPSK 1/2	17.2	18.2

Note: Since the maximum output power is 20.3 dBm, the maximum allowed antenna gain is 15.7 dBi. ( $G \leq 15.7$  dBi). Therefore, if an antenna with higher than 15.7 dBi gain is used, the output power must be reduced accordingly. The calculated gain  $G$  may include an antenna cable loss, e.g.  $G = G_a - \text{Cable Loss}$ , where  $G_a$  is the gain of the antenna.

4.2 6 dB RF Bandwidth  
FCC Rule 15.247(a)(2):

Requirements

The minimum 6-dB bandwidth shall be at least 500 kHz

Procedure

The antenna port of the EUT was connected to the input of a spectrum analyzer. Analyzer RES BW was set to 100 kHz. For each RF output channel investigated, the spectrum analyzer center frequency was set to the channel carrier. A PEAK output reading was taken, a DISPLAY line was drawn 6 dB lower than PEAK level. The 6-dB bandwidth was determined from where the channel output spectrum intersected the display line.

Test Result

<b>Frequency MHz</b>	<b>Modulation</b>	<b>6-dB Bandwidth (measured from integrated BSU RF output) MHz</b>	<b>6-dB Bandwidth (measured from connectorized BSU antenna connector) MHz</b>
5740	QAM16	21.4	21.7
5775	QAM16	21.5	21.0
	QPSK 3/4	21.8	21.7
	QPSK 1/2	21.8	21.6
5810	QAM16	21.3	22.0

On the plots 2.1 – 2.3 the 6-dB bandwidth is presented for QAM16 modulation for the configuration with external antenna connector.

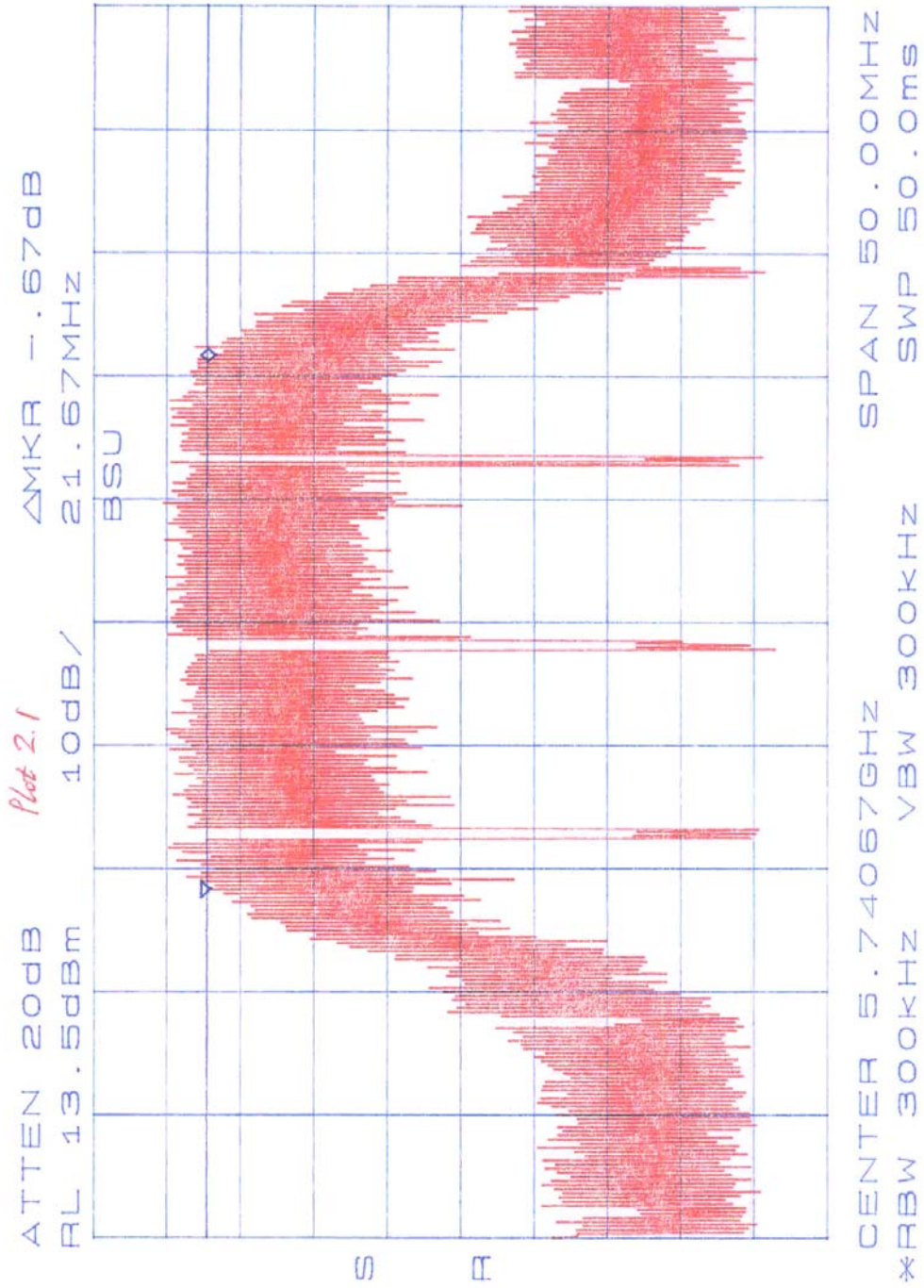

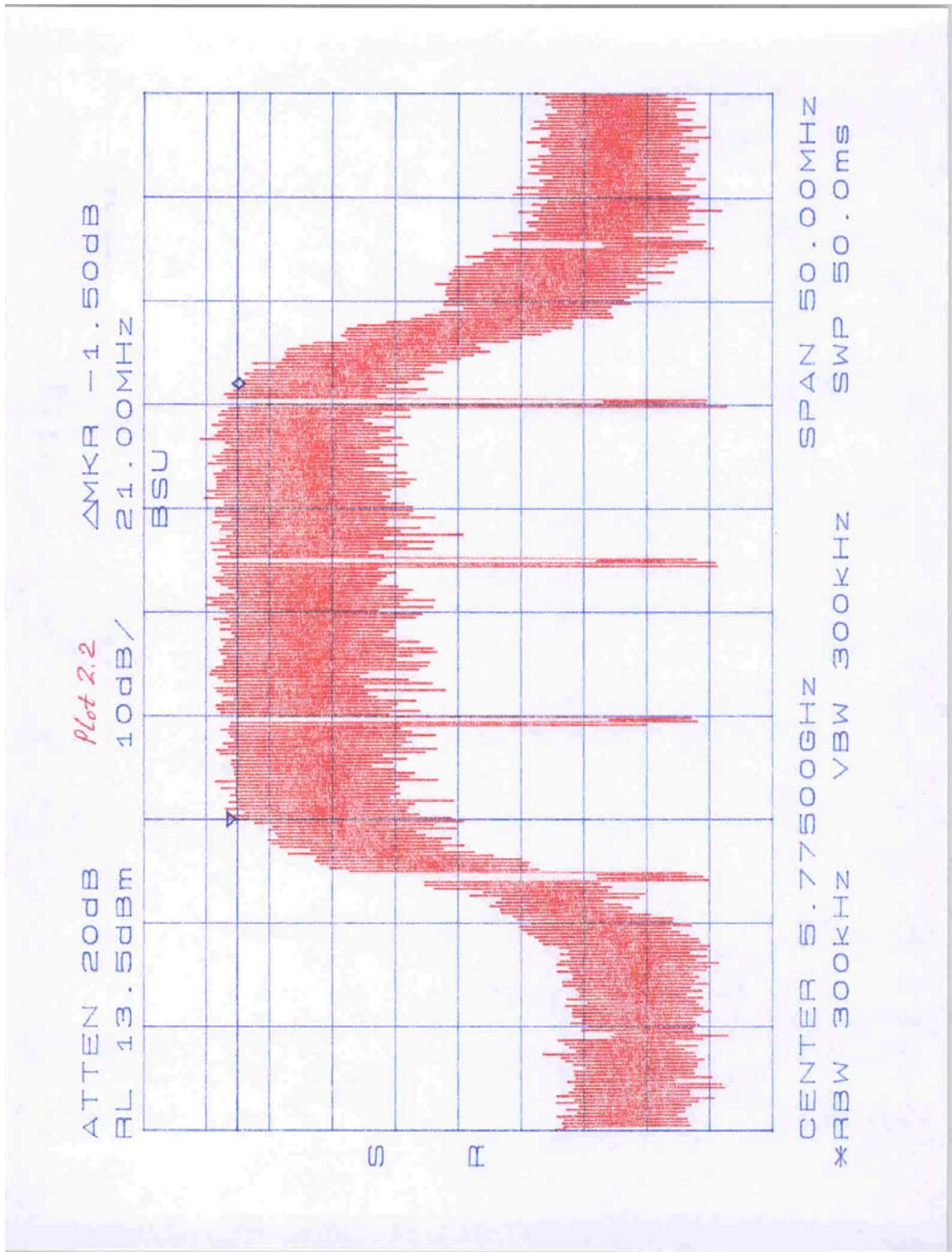

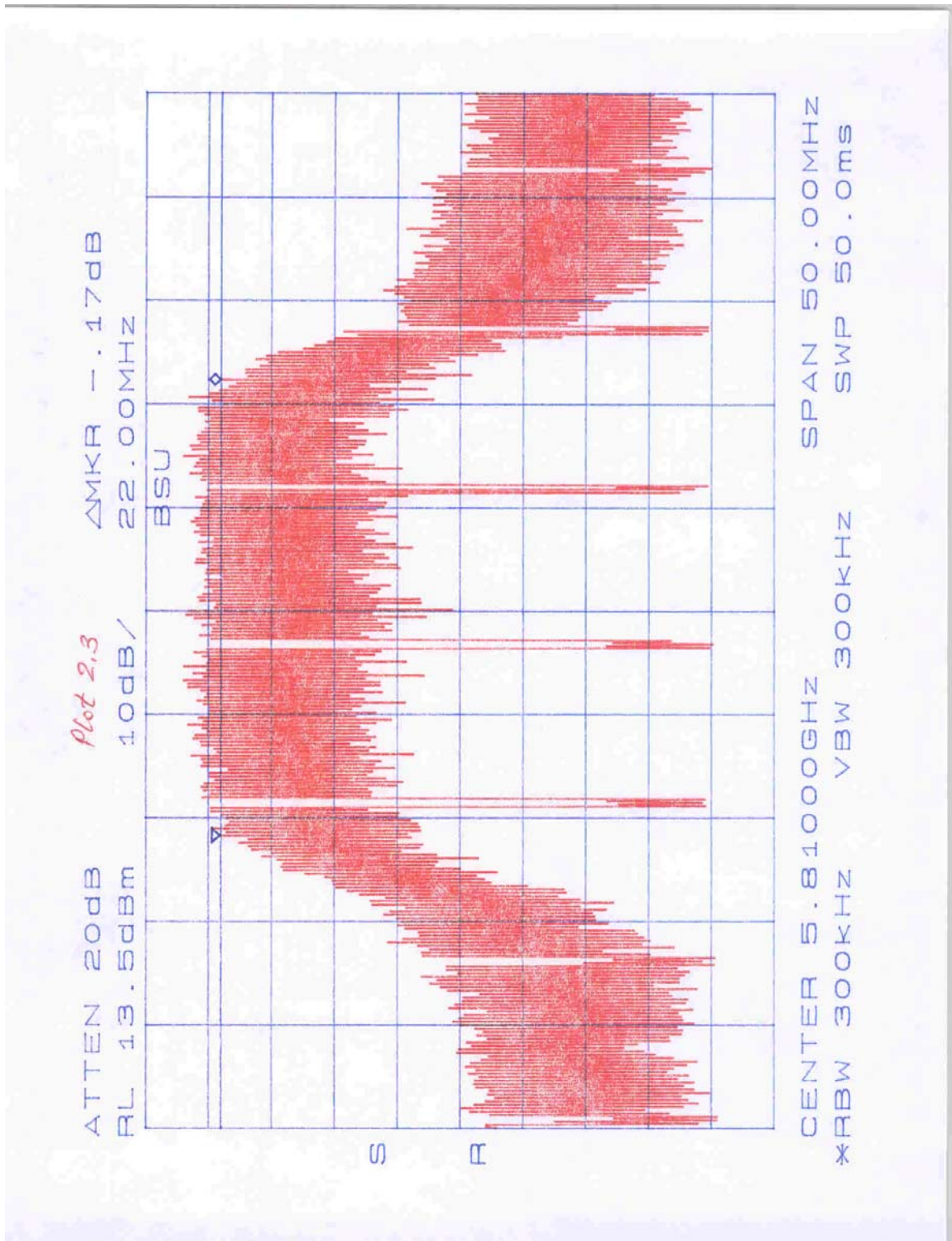

4.3 Power Density  
 FCC Rule: 15.247(d)

Requirements

The peak power spectral density shall not be greater than 8 dBm in any 3 kHz band during any time interval of continuous transmission.

Procedure

The spectrum analyzer RES BW was set to 3 kHz. The START and STOP frequencies were set to the band edges of the maximum output pass-band. If there is no clear maximum amplitude in any given portion of the band, it may be necessary to make measurements at a number of bands defined by several START and STOP frequency pairs. Total SWEEP TIME is calculated as follows:

$$\text{SWEEP TIME (SEC)} = (\text{Fstop, kHz} - \text{Fstart, kHz}) / 3 \text{ kHz}$$

Antenna output of the EUT was coupled directly to spectrum analyzer; if an external attenuator and/or cable was used, these losses are compensated for with the analyzer OFFSET function.

Frequency Span = 1500 kHz  
 Sweep Time = Frequency Span / 3 kHz = 500 Seconds

Test Result

Frequency MHz	Modulation	Power Density (measured from integrated BSU RF output) dBm		Power Density (measured from connectorized BSU antenna connector) dBm	
		measured	plot	measured	plot
5740	QAM16	-14.3	3.1	-14.5	3.4
5775	QAM16	-14.0	3.2	-13.7	3.5
	QPSK 3/4	-	-	-12.2	3.7
	QPSK 1/2	-	-	-12.0	3.8
5810	QAM16	-11.5	3.3	-11.5	3.6

The EUT passed by 19.5 dB.

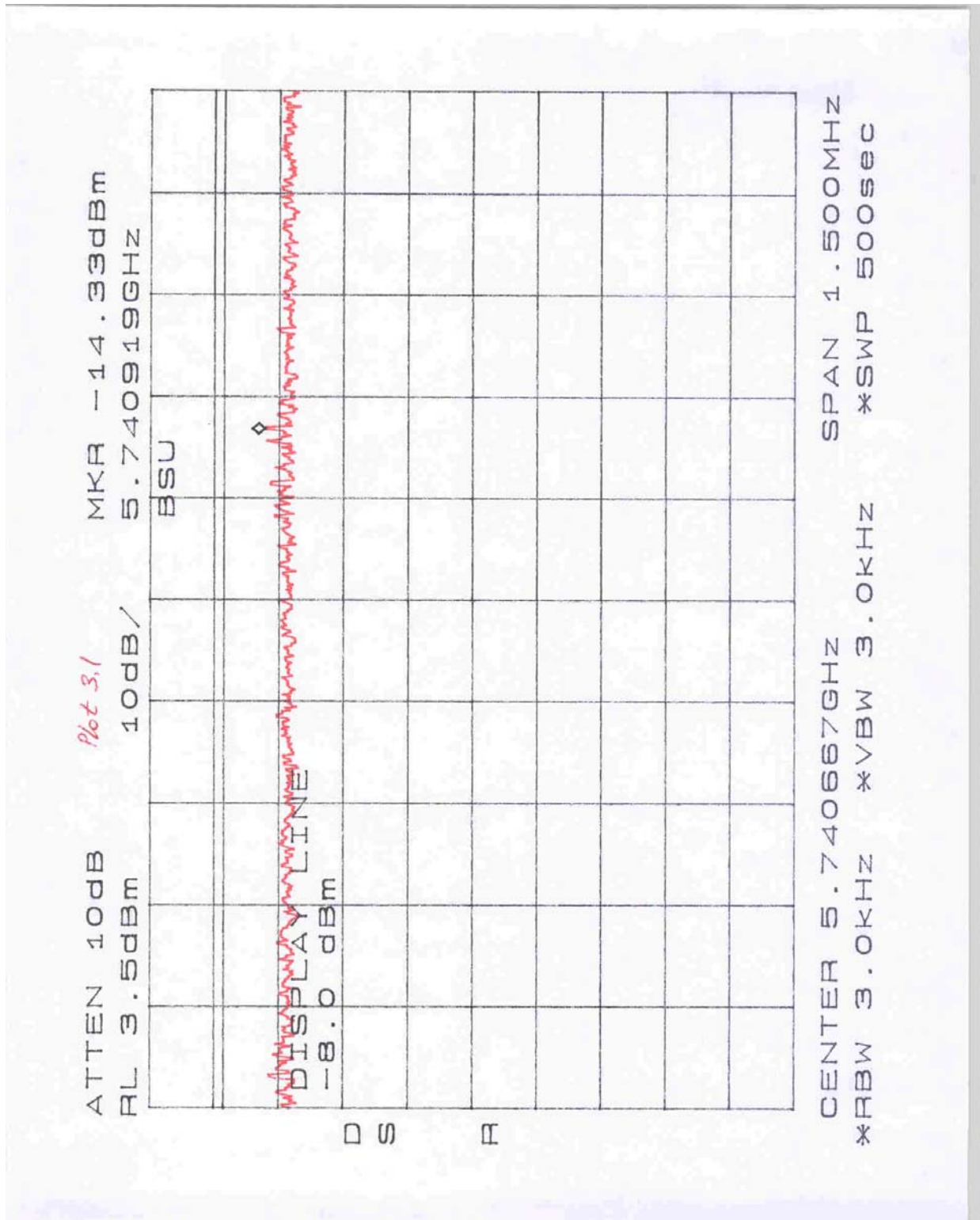



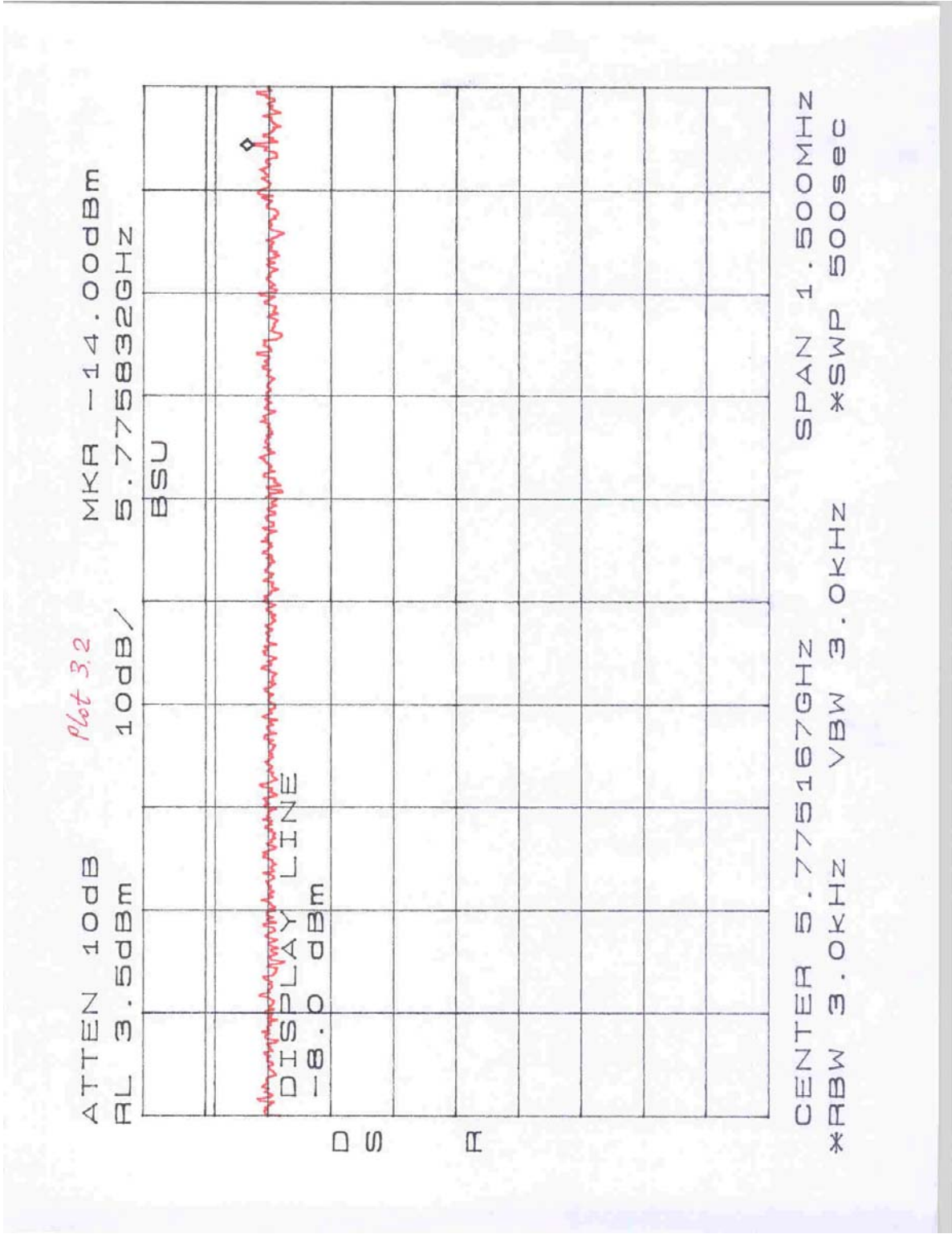

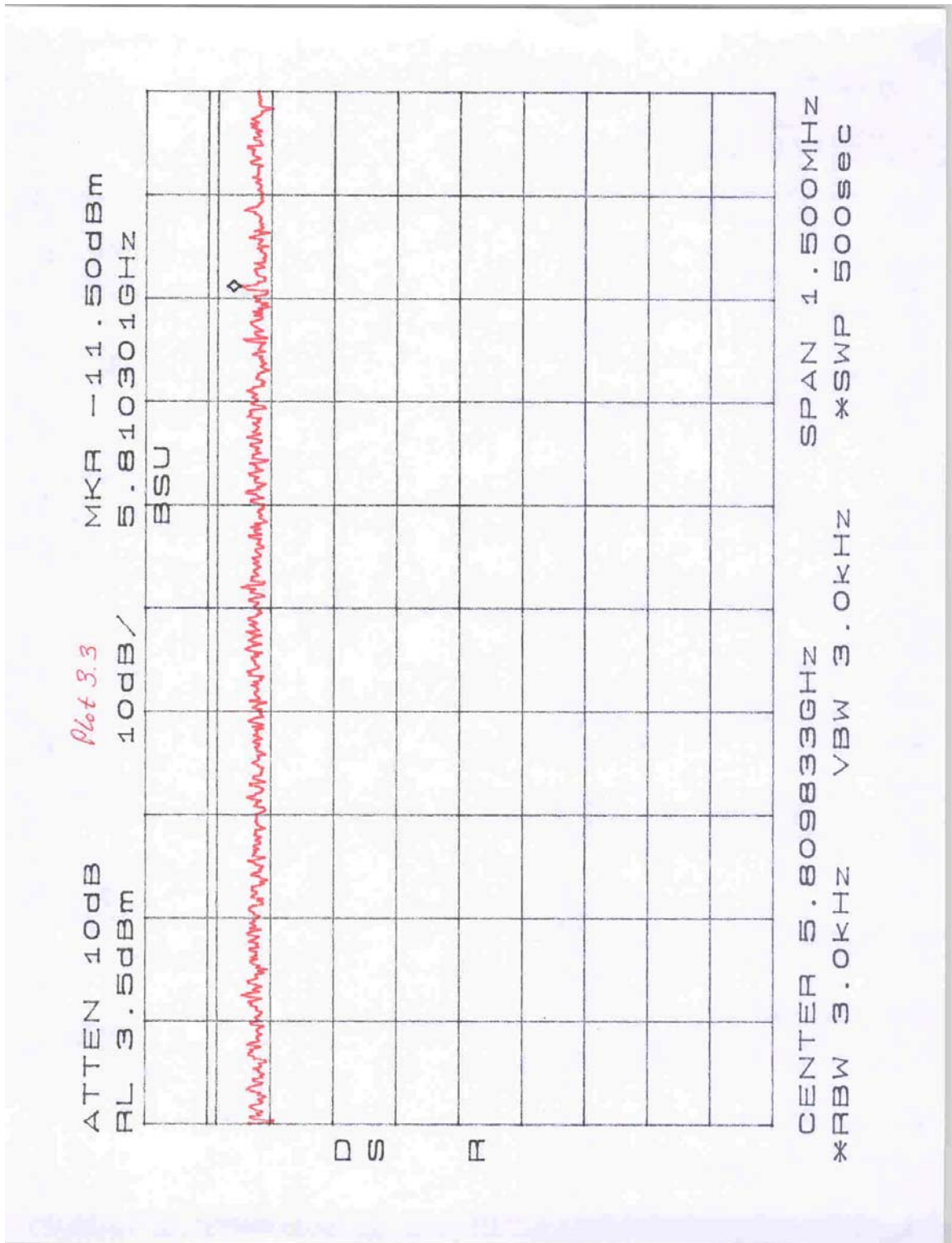

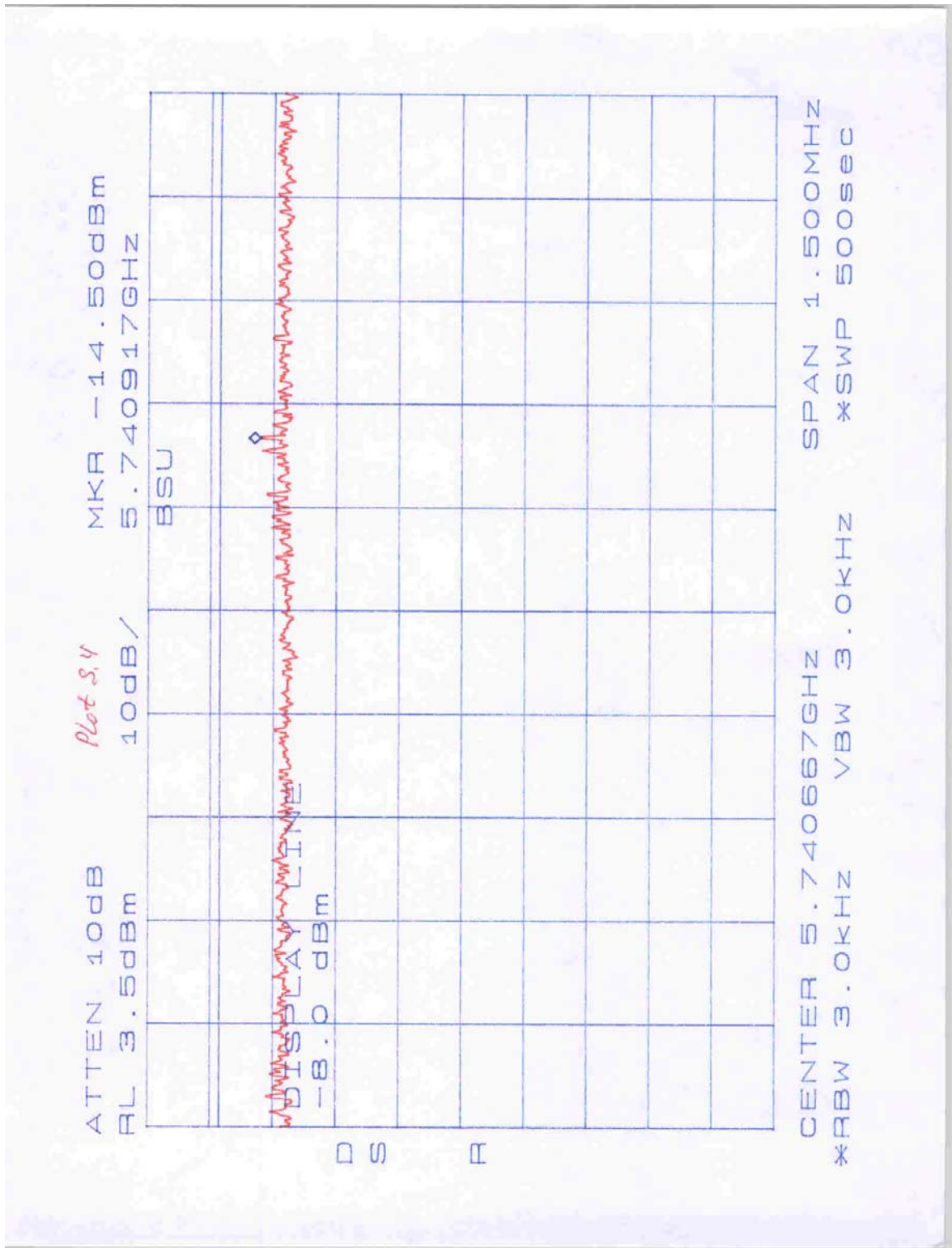

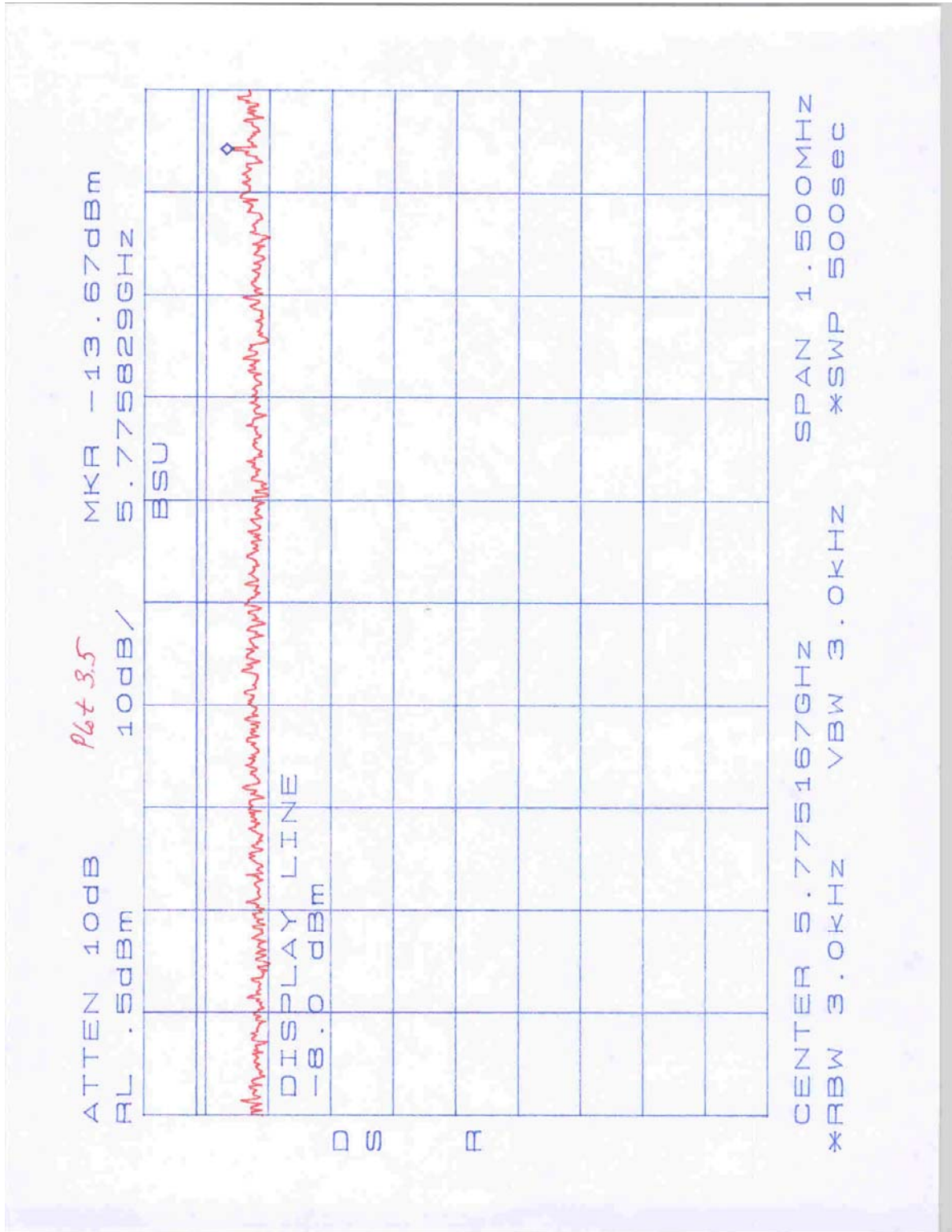

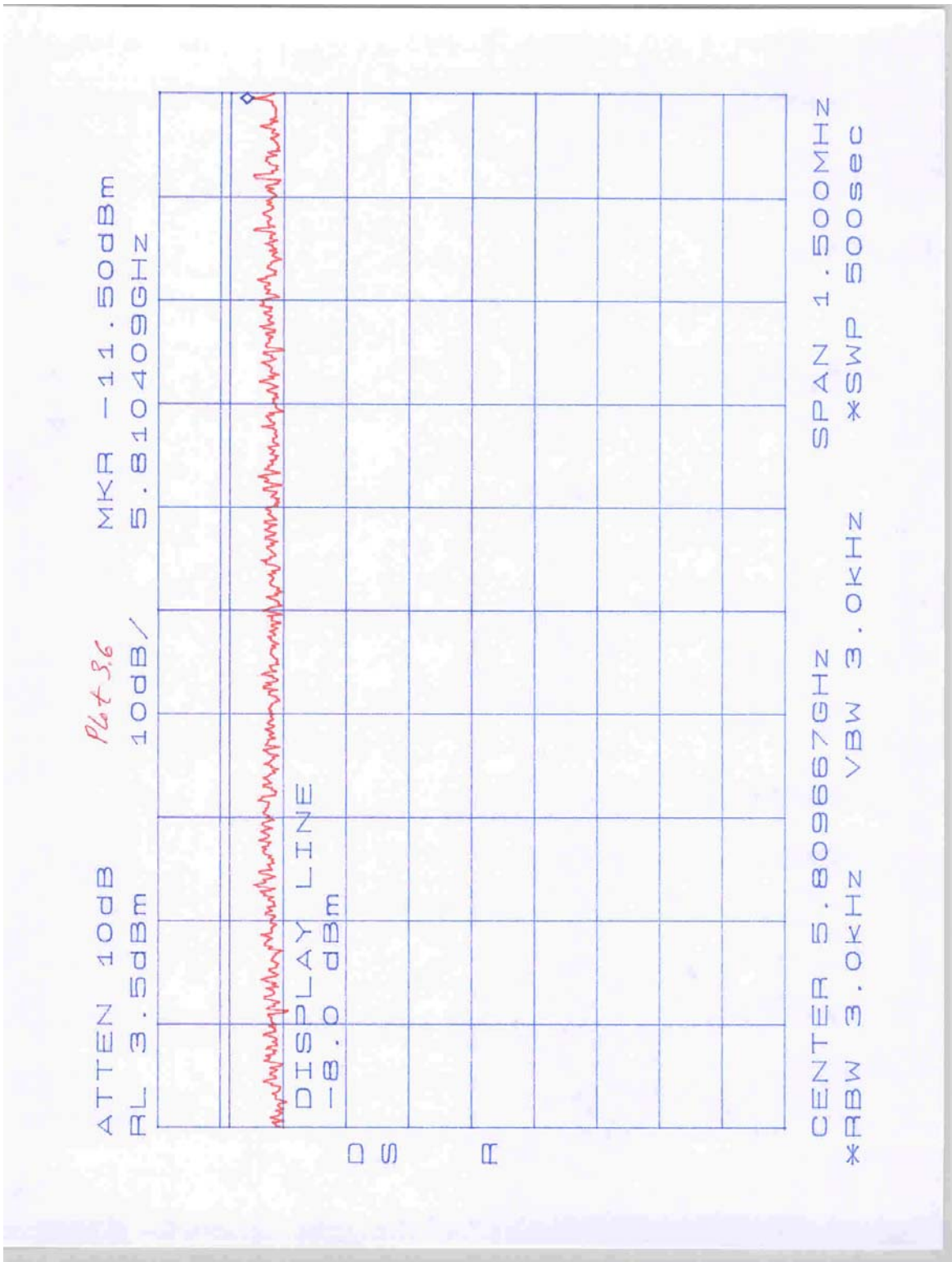

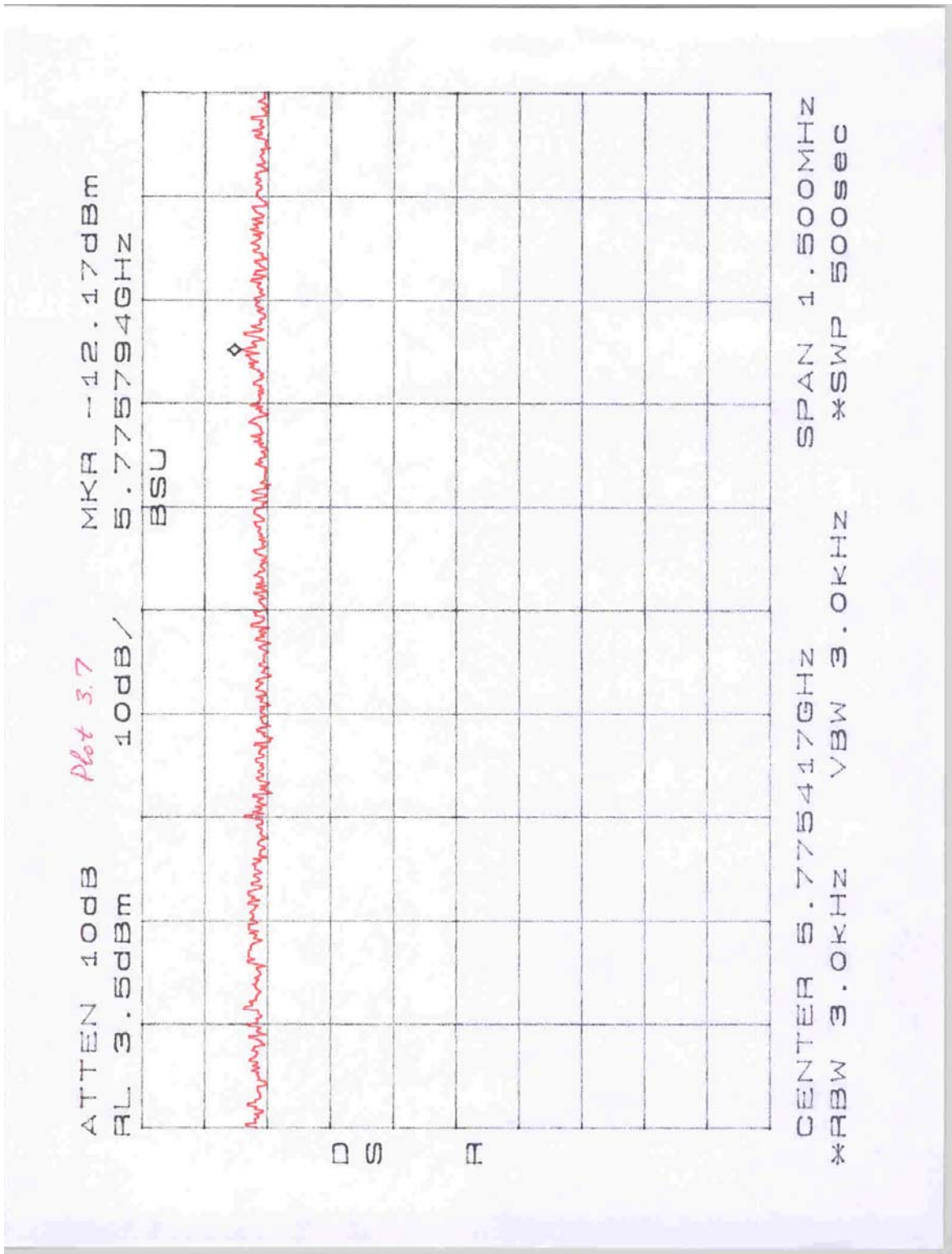



4.4 Out-of-Band Conducted Emissions  
FCC Rule: 15.247(c)

Requirements

In any 100 kHz bandwidth outside the EUT pass-band, the RF power shall be at least 20 dB below that of the maximum in-band 100 kHz emission.

Procedure

A spectrum analyzer was connected to the antenna port of the transmitter. Analyzer Resolution Bandwidth was set to 100 kHz. For each channel investigated, the in-band and out-of-band emission measurements were performed.

The out-of-band emissions were measured from 10 MHz to 40 GHz for the configuration with an external antenna connector for QAM16 modulation. In addition, measurements on the band-edge frequencies were performed for both configuration for QPSK  $\frac{3}{4}$  and QPSK  $\frac{1}{2}$  modulations.

Test Result

Refer to the following plots in Appendix A for the test result.

Plot	Point of measurement	Modulation	Description
4.1a–4.1e	connectorized BSU antenna connector	QAM16	low channel, scan 30 MHz to 40 GHz
4.2a–4.2d	connectorized BSU antenna connector	QAM16	middle channel, scan 30 MHz to 40 GHz
4.3a–4.3d	connectorized BSU antenna connector	QAM16	high channel, scan 30 MHz to 40 GHz
4.4a–4.4b	connectorized BSU antenna connector	QPSK $\frac{3}{4}$	low channel, scan 4 GHz to 5.85 GHz
4.4c–4.4d	connectorized BSU antenna connector	QPSK $\frac{1}{2}$	low channel, scan 4 GHz to 5.85 GHz
4.5a–4.5b	connectorized BSU antenna connector	QPSK $\frac{3}{4}$	high channel, scan 5.725 GHz to 8 GHz
4.5c–4.5d	connectorized BSU antenna connector	QPSK $\frac{1}{2}$	high channel, scan 5.725 GHz to 8 GHz
4.6a–4.6b	integrated BSU RF output	QAM16	low channel, scan 5 GHz to 5.85 GHz
4.6c–4.6d	integrated BSU RF output	QPSK $\frac{3}{4}$	low channel, scan 5 GHz to 5.85 GHz
4.6e–4.6f	integrated BSU RF output	QPSK $\frac{1}{2}$	low channel, scan 5 GHz to 5.85 GHz
4.7a–4.7b	integrated BSU RF output	QAM16	high channel, scan 5.725 GHz to 10 GHz
4.7c–4.7d	integrated BSU RF output	QPSK $\frac{3}{4}$	high channel, scan 5.725 GHz to 10 GHz
4.7e–4.7f	integrated BSU RF output	QPSK $\frac{1}{2}$	high channel, scan 5.725 GHz to 10 GHz

The EUT passed by more than 20 dB.



4.6 Transmitter Radiated Emissions  
FCC Rules: 15.247 (c), 15.205, 15.209

Procedure

Radiated emission measurements were performed from 30 MHz to 40,000 MHz. Spectrum Analyzer Resolution Bandwidth is 100 kHz or greater for frequencies 30 MHz to 1000 MHz, 1 MHz - for frequencies above 1000 MHz.

The EUT is placed on the wooden turntable. If the EUT attaches to peripherals, they are connected and operational (as typical as possible). During testing, all cables were manipulated to produce worst-case emissions. The signal is maximized through rotation. The antenna height and polarization are varied during the search for maximum signal level. The antenna height is varied from 1 to 4 meters.

Radiated emissions are taken at three meters unless the signal level is too low for measurement at that distance. If necessary, a pre-amplifier is used and/or the test is conducted at a closer distance. All readings are extrapolated back to the equivalent three-meter reading using inverse scaling with distance.

Data is included of the worst-case configuration (the configuration which resulted in the highest emission levels). A sample calculation, configuration photographs and data tables of the emissions are included. All measurements were performed with peak detection unless otherwise specified.

Field Strength Calculation

$$FS = RA + AF + CF - AG$$

Where FS = Field Strength in dB( $\mu$ V/m)

RA = Receiver Amplitude (including preamplifier) in dB( $\mu$ V)

CF = Cable Attenuation Factor in dB

AF = Antenna Factor in dB(1/m)

AG = Amplifier Gain in dB

Assume a receiver reading of 52.0 dB( $\mu$ V) is obtained. The antenna factor of 7.4 dB(1/m) and cable factor of 1.6 dB is added. The amplifier gain of 29 dB is subtracted, giving field strength of 32 dB( $\mu$ V/m). This value in dB( $\mu$ V/m) was converted to its corresponding level in  $\mu$ V/m.

$$RA = 52.0 \text{ dB}(\mu\text{V}) \quad AF = 7.4 \text{ dB}(1/\text{m})$$

$$CF = 1.6 \text{ dB} \quad AG = 29.0 \text{ dB}$$

$$FS = 52 + 7.4 + 1.6 - 29 = 32 \text{ dB}(\mu\text{V}/\text{m})$$

$$\text{Level in } \mu\text{V}/\text{m} = \text{Common Antilogarithm } [(32 \text{ dB}(\mu\text{V}/\text{m})/20) = 39.8 \mu\text{V}/\text{m}$$

Result

The data on the following pages list the significant emission frequencies, the limit and the margin of compliance. The EUT passed by 7.6 dB.

<b>Company:</b>	PROXIM	<b>Model #:</b>		<b>Standard_</b>	FCC § 15.247(R.B.)	
<b>EUT:</b>	BSU with Internal Ant.	<b>S/N #:</b>		<b>Limits_</b>	2	
<b>Project #:</b>	3034904	<b>Test Date:</b>	June 25, 2003	<b>Test Distance_</b>	1 meter	
<b>Test Mode:</b>	Tx	<b>Engineer:</b>	AK.	<b>Duty Relaxation</b>	0 dB	
<b>Antenna Used</b>		<b>Pre-Amp Used</b>			<b>Cable Used</b>	
<b>Number:</b>	14      8      22	10      4      13	10      0      0			
<b>Model:</b>	EMCO 3115    3160-9    3160-10	AFT18855    None    ACO/400	NPS72-1    None    None			

**TX at 5740 MHz**

Frequency	Reading	Detector	Ant. P/A/Q	Ant. #	Ant. #	Pol. H/V	Ant. Factor	Pre-Amp	Insert. Loss	DCF	Net	Limit @3m	Margin
MHz	dB(μV)						dB(1/m)	dB	dB	dB	dB(μV/m)	dB(μV/m)	dB
11480	64.0	Peak	14	10	H	40.4	39.9	4.2	-9.5	59.2	74.0	-14.8	
11480	51.0	Ave.	14	10	H	40.4	39.9	4.2	-9.5	46.2	54.0	-7.8	
22960	37.7 *	Peak	21	13	H	40.4	23.3	10.5	-9.5	55.8	74.0	-18.2	
22960	24.8 *	Ave.	21	13	H	40.4	23.3	10.5	-9.5	42.9	54.0	-11.1	

**TX at 5775 MHz**

Frequency	Reading	Detector	Ant. P/A/Q	Ant. #	Ant. #	Pol. H/V	Ant. Factor	Pre-Amp	Insert. Loss	DCF	Net	Limit @3m	Margin
MHz	dB(μV)						dB(1/m)	dB	dB	dB	dB(μV/m)	dB(μV/m)	dB
11550	63.2	Peak	14	10	V	40.4	39.9	4.2	-9.5	58.4	74.0	-15.6	
11550	50.7	Ave.	14	10	V	40.4	39.9	4.2	-9.5	45.9	54.0	-8.1	
23100	38.9 *	Peak	21	13	H	40.4	23.3	10.5	-9.5	55.2	74.0	-18.8	
23100	25.2 *	Ave.	21	13	H	40.4	23.3	10.5	-9.5	43.3	54.0	-10.7	

**TX at 5810 MHz**

Frequency	Reading	Detector	Ant. P/A/Q	Ant. #	Ant. #	Pol. H/V	Ant. Factor	Pre-Amp	Insert. Loss	DCF	Net	Limit @3m	Margin
MHz	dB(μV)						dB(1/m)	dB	dB	dB	dB(μV/m)	dB(μV/m)	dB
11620	60.2	Peak	14	10	V	40.4	39.9	4.2	-9.5	55.4	74.0	-18.6	
11620	51.0	Ave.	14	10	V	40.4	39.9	4.2	-9.5	46.2	54.0	-7.8	

<b>Notes:</b>	a) D.C.F.:Distance Correction Factor b) Insert. Loss (dB) = Cable A + Cable B + Cable C . c) Net (dB) = Reading + Antenna Factor - Pre-amp + Insert. Loss d) Negative signs (-) in Margin column signify levels below the limits. e) All other emissions not reported are below the equipment noise floor which is at least 10 dB below the limits. f) * Noise floor reading
---------------	---

<b>Company:</b>	PROXIM	<b>Model #:</b>		<b>Standard_</b>	FCC § 15.247(R.B.)				
<b>EUT:</b>	BSU with External Ant.	<b>S/N #:</b>		<b>Limits_</b>	2				
<b>Project #:</b>		<b>Test Date:</b>	July 03, 2003	<b>Test Distance_</b>	1 meter				
<b>Test Mode:</b>	Tx	<b>Engineer:</b>	AK.	<b>Duty Relaxation</b>	0 dB				
	<b>Antenna Used</b>			<b>Pre-Amp Used</b>		<b>Cable Used</b>			
<b>Number:</b>	14	21	22	10	4	13	10	0	0
<b>Model:</b>	EMCO 3115	3160-9	3160-10	AFT18855	None	ACO/400	NPS72-1	None	None

**OMNI Antenna, model: 5830AN**

**TX at 5740 MHz**

Frequency	Reading	Detector	Ant. #	Amp. #	Ant. Pol.	Ant. Factor	Pre-Amp	Insert. Loss	D. C. F.	Net	Limit @3m	Margin
MHz	dB(μV)	P/A/Q	#	#	H/V	dB(1/m)	dB	dB	dB	dB(μV/m)	dB(μV/m)	dB
11480	59.0	Peak	14	10	V	36.9	39.9	4.2	-9.5	50.7	74.0	-23.3
11480	46.5	Ave.	14	10	V	36.9	39.9	4.2	-9.5	38.2	54.0	-15.8
22960	38.3*	Peak	21	13	V/H	40.4	23.3	10.5	-9.5	56.4	74.0	-17.6
22960	27.8*	Ave.	21	13	V/H	40.4	23.3	10.5	-9.5	45.9	54.0	-8.1

**TX at 5775 MHz**

Frequency	Reading	Detector	Ant. #	Amp. #	Ant. Pol.	Ant. Factor	Pre-Amp	Insert. Loss	D. C. F.	Net	Limit @3m	Margin
MHz	dB(μV)	P/A/Q	#	#	H/V	dB(1/m)	dB	dB	dB	dB(μV/m)	dB(μV/m)	dB
11550	58.9	Peak	14	10	V	36.9	39.9	4.2	-9.5	50.6	74.0	-23.4
11550	45.4	Ave.	14	10	V	36.9	39.9	4.2	-9.5	37.1	54.0	-16.9
23100	38.1*	Peak	21	13	V/H	40.4	23.3	10.5	-9.5	56.2	74.0	-17.8
23100	27.6*	Ave.	21	13	V/H	40.4	23.3	10.5	-9.5	45.7	54.0	-8.3

**TX at 5810 MHz**

Frequency	Reading	Detector	Ant. #	Amp. #	Ant. Pol.	Ant. Factor	Pre-Amp	Insert. Loss	D. C. F.	Net	Limit @3m	Margin
MHz	dB(μV)	P/A/Q	#	#	H/V	dB(1/m)	dB	dB	dB	dB(μV/m)	dB(μV/m)	dB
11620	54.2	Peak	14	10	V	36.9	39.9	4.2	-9.5	45.9	74.0	-28.1
11620	42.2	Ave.	14	10	V	36.9	39.9	4.2	-9.5	33.9	54.0	-20.1

<b>Notes:</b>	<ul style="list-style-type: none"> <li>a) D.C.F.:Distance Correction Factor</li> <li>b) Inset. Loss (dB) = Cable A + Cable B + Cable C .</li> <li>c) Net (dB) = Reading + Antenna Factor - Pre-amp + Inset. Loss</li> <li>d) Negative signs (-) in Margin column signify levels below the limits.</li> <li>e) All other emissions not reported are below the equipment noise floor which is at least 10 dB below the limits.</li> <li>f) * Noise floor reading</li> </ul>
---------------	---

<b>Company:</b>	PROXIM	<b>Model #:</b>		<b>Standard_</b>	FCC § 15.247(R.B.)				
<b>EUT:</b>	BSU with External Ant.	<b>S/N #:</b>		<b>Limits_</b>	2				
<b>Project #:</b>	3034904	<b>Test Date:</b>	July 03, 2003	<b>Test Distance_</b>	1 meter				
<b>Test Mode:</b>	Tx	<b>Engineer:</b>	AK.	<b>Duty Relaxation</b>	0 dB				
	<b>Antenna Used</b>		<b>Pre-Amp Used</b>			<b>Cable Used</b>			
<b>Number:</b>	14	21	22	10	4	13	10	0	0
<b>Model:</b>	EMCO 3115	3160-9	3160-10	AFT18855	None	ACO/400	NPS72-1	None	None

**OMNI Antenna, model: MT-483003/N**

**TX at 5740 MHz**

Frequency	Reading	Detector	Ant. #	Amp. #	Ant. Pol.	Ant. Factor	Pre-Amp	Insert. Loss	D. C. F.	Net	Limit @3m	Margin
MHz	dB(μV)	P/A/Q	#	#	H/V	dB(1/m)	dB	dB	dB	dB(μV/m)	dB(μV/m)	dB
11480	60.6	Peak	14	10	V	36.9	39.9	4.2	-9.5	52.3	74.0	-21.7
11480	47.2	Ave.	14	10	V	36.9	39.9	4.2	-9.5	38.9	54.0	-15.1
22960	36.0*	Peak	21	13	V/H	40.4	23.3	10.5	-9.5	54.1	74.0	-15.3
22960	24.8*	Ave.	21	13	V/H	40.4	23.3	10.5	-9.5	42.9	54.0	-11.1

**TX at 5775 MHz**

Frequency	Reading	Detector	Ant. #	Amp. #	Ant. Pol.	Ant. Factor	Pre-Amp	Insert. Loss	D. C. F.	Net	Limit @3m	Margin
MHz	dB(μV)	P/A/Q	#	#	H/V	dB(1/m)	dB	dB	dB	dB(μV/m)	dB(μV/m)	dB
11550	59.1	Peak	14	10	V	36.9	39.9	4.2	-9.5	50.8	74.0	-23.2
11550	44.8	Ave.	14	10	V	36.9	39.9	4.2	-9.5	36.5	54.0	-17.5
23100	36.0*	Peak	21	13	V/H	40.4	23.3	10.5	-9.5	54.1	74.0	-19.9
23100	24.6*	Ave.	21	13	V/H	40.4	23.3	10.5	-9.5	42.7	54.0	-11.3

**TX at 5810 MHz**

Frequency	Reading	Detector	Ant. #	Amp. #	Ant. Pol.	Ant. Factor	Pre-Amp	Insert. Loss	D. C. F.	Net	Limit @3m	Margin
MHz	dB(μV)	P/A/Q	#	#	H/V	dB(1/m)	dB	dB	dB	dB(μV/m)	dB(μV/m)	dB
11620	57.2	Peak	14	10	V	36.9	39.9	4.2	-9.5	48.9	74.0	-25.1
11620	43.9	Ave.	14	10	V	36.9	39.9	4.2	-9.5	35.6	54.0	-18.4

<b>Notes:</b>	<p>a) D.C.F.:Distance Correction Factor</p> <p>b) Insert. Loss (dB) = Cable A + Cable B + Cable C .</p> <p>c) Net (dB) = Reading + Antenna Factor - Pre-amp + Insert. Loss</p> <p>d) Negative signs (-) in Margin column signify levels below the limits.</p> <p>e) All other emissions not reported are below the equipment noise floor which is at least 10 dB below the limits.</p> <p>f) * Noise floor reading</p>
---------------	--

<b>Company:</b>	PROXIM	<b>Model #:</b>		<b>Standard_</b>	FCC § 15.247(R.B.)				
<b>EUT:</b>	BSU with External Ant.	<b>S/N #:</b>		<b>Limits_</b>	2				
<b>Project #:</b>		<b>Test Date:</b>	July 03, 2003	<b>Test Distance_</b>	1 meter				
<b>Test Mode:</b>	Tx	<b>Engineer:</b>	AK.	<b>Duty Relaxation</b>	0 dB				
	<b>Antenna Used</b>		<b>Pre-Amp Used</b>			<b>Cable Used</b>			
<b>Number:</b>	14	21	22	10	4	13	10	0	0
<b>Model:</b>	EMCO 3115	3160-9	3160-10	AFT18855	None	ACO/400	NPS72-1	None	None

### Flat Panel Antenna, model: SEC-5V/H-60-18

#### TX at 5740 MHz

Frequency	Reading	Detector	Ant. #	Amp. #	Ant. Pol.	Ant. Factor	Pre-Amp	Insert. Loss	D. C. F.	Net	Limit @3m	Margin
MHz	dB(μV)	P/A/Q	#	#	H/V	dB(1/m)	dB	dB	dB	dB(μV/m)	dB(μV/m)	dB
11480	63.1	Peak	14	10	V	36.9	39.9	4.2	-9.5	51.9	74.0	-22.1
11480	51.9	Ave.	14	10	V	36.9	39.9	4.2	-9.5	43.6	54.0	-10.4
22960	37.3*	Peak	21	13	V/H	40.4	23.3	10.5	-9.5	55.4	74.0	-18.6
22960	24.8*	Ave.	21	13	V/H	40.4	23.3	10.5	-9.5	42.9	54.0	-11.1

#### TX at 5775 MHz

Frequency	Reading	Detector	Ant. #	Amp. #	Ant. Pol.	Ant. Factor	Pre-Amp	Insert. Loss	D. C. F.	Net	Limit @3m	Margin
MHz	dB(μV)	P/A/Q	#	#	H/V	dB(1/m)	dB	dB	dB	dB(μV/m)	dB(μV/m)	dB
11550	62.9	Peak	14	10	V	36.9	39.9	4.2	-9.5	54.6	74.0	-15.4
11550	54.9	Ave.	14	10	V	36.9	39.9	4.2	-9.5	46.6	54.0	-7.6
23100	38.1*	Peak	21	13	V/H	40.4	23.3	10.5	-9.5	56.2	74.0	-17.8
23100	24.6*	Ave.	21	13	V/H	40.4	23.3	10.5	-9.5	42.7	54.0	-11.3

#### TX at 5810 MHz

Frequency	Reading	Detector	Ant. #	Amp. #	Ant. Pol.	Ant. Factor	Pre-Amp	Insert. Loss	D. C. F.	Net	Limit @3m	Margin
MHz	dB(μV)	P/A/Q	#	#	H/V	dB(1/m)	dB	dB	dB	dB(μV/m)	dB(μV/m)	dB
11620	66.7	Peak	14	10	V	36.9	39.9	4.2	-9.5	58.4	74.0	-15.6
11620	52.7	Ave.	14	10	V	36.9	39.9	4.2	-9.5	44.4	54.0	-9.6

<b>Notes:</b>	<p>a) D.C.F.:Distance Correction Factor</p> <p>b) Insert. Loss (dB) = Cable A + Cable B + Cable C .</p> <p>c) Net (dB) = Reading + Antenna Factor - Pre-amp + Insert. Loss</p> <p>d) Negative signs (-) in Margin column signify levels below the limits.</p> <p>e) All other emissions not reported are below the equipment noise floor which is at least 10 dB below the limits.</p> <p>f) * Noise floor reading</p>
---------------	--

4.7 Radiated Emissions from Digital Section of Transceiver  
FCC Ref: 15.109

Procedure

Radiated emission measurements were performed from 30 MHz to 1000 MHz. Spectrum Analyzer Resolution Bandwidth is 100 kHz or greater. See also section 4.6 for the test procedure and field strength calculation.

Result

The result is presented on the following pages.  
The EUT passed by 0.7 dB.

Radiated Emissions FCC Part 15 Class B

Operator: Arkadi Kaplan  
 ITS Job Number: 3044904  
 10-Jul-03

Model: BSU with internal antenna  
 Company: Proxim Corp.

Frequency MHz	Pol.	Quasi- Pk FS dB(uV/m)	FS Limit@3m dB(uV/m)	Margin dB	RA dB(uV)	AG dB	CF dB	AF dB(1/m)	Atten dB
43.8	V	33.1	40.0	-6.9	53.0	32.4	0.6	8.9	3
58.4	V	26.7	40.0	-13.3	50.1	32.3	0.8	5.2	3
92.2	V	30.1	43.5	-13.4	51.0	32.3	0.9	7.6	3
94.9	V	40.4	43.5	-3.1	61.3	32.3	0.9	7.4	3
96.4	V	42.8	43.5	-0.7	63.9	32.3	0.9	7.4	3
101.0	V	40.5	43.5	-3.0	61.6	32.3	0.9	7.3	3

Test Mode: Tx/Rx

Temp: 22.5 C

Hum: 43.2 %

Radiated Emissions FCC Part 15 Class B

Operator: Arkadi Kaplan  
 ITS Job Number: 3044904  
 17-Jul-03

Model: BSU with external antenna  
 Company: Proxim Corp.

Frequency MHz	Pol	Quasi Pk FS dB(uV/m)	FS Limit@3m dB(uV/m)	Margin dB	RA dB(uV)	AG dB	CF dB	AF dB(1/m)	Atten dB
42.1	V	30.2	40	-9.8	51.3	32.4	0.6	7.7	3
57.4	V	37.3	40	-2.7	60.5	32.3	0.7	5.4	3
64.3	V	30.6	40	-9.4	54.2	32.3	0.8	4.9	3
124.4	H	27.8	43.5	-15.7	48.8	32.3	1.0	7.3	3
188.7	H	32.7	43.5	-10.8	51.1	32.3	1.3	9.6	3
268.3	H	36.4	46.0	-9.6	51.2	32.2	1.5	12.9	3
301.1	H	29.0	46.0	-17.0	42.6	32.2	1.6	14.0	3

Test Mode: Tx/Rx

Temp: 22.1 C

Hum: 42.9 %





4.8 Radiated Emissions from Receiver Section of Transceiver (L.O. Radiation)  
FCC Ref: 15.109, 15.111

Not required - EUT operation above 960 MHz only.

4.9 AC Line Conducted Emission  
FCC Rule 15.207:

AC line conducted emission test was performed according the ANSI C63.4 standard. The EUT was connected to AC Line through the LISNs.

For the test result, see attached plots.  
The EUT passed by 3.7 dB.

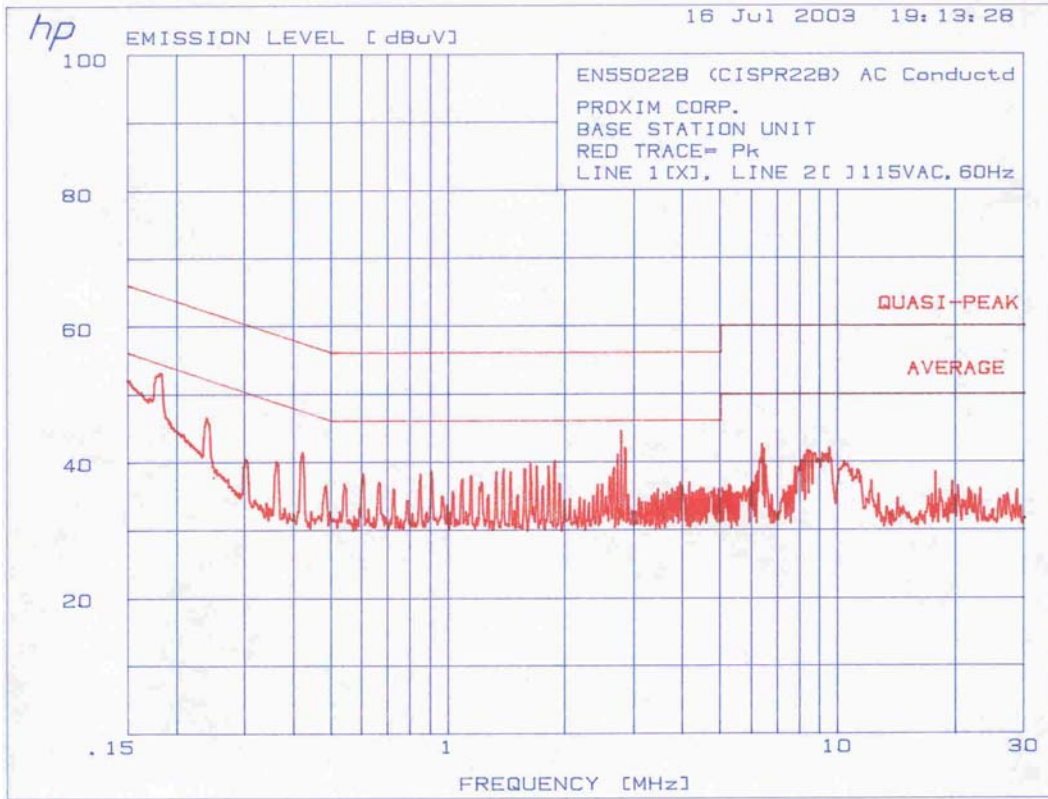

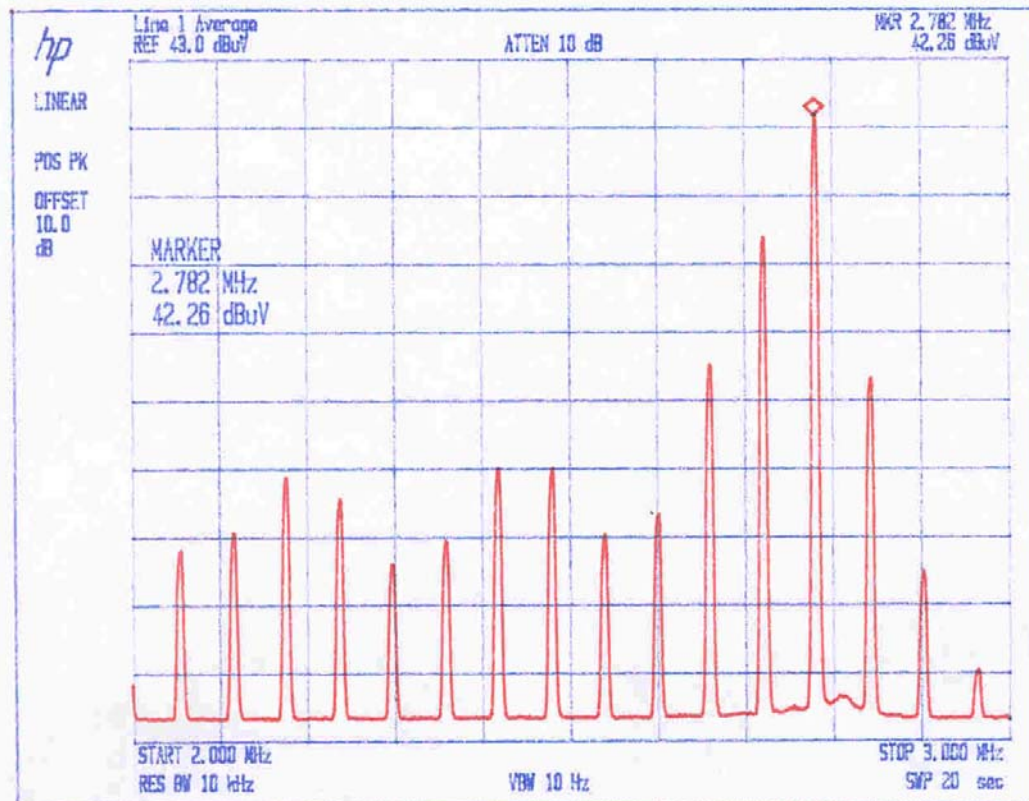
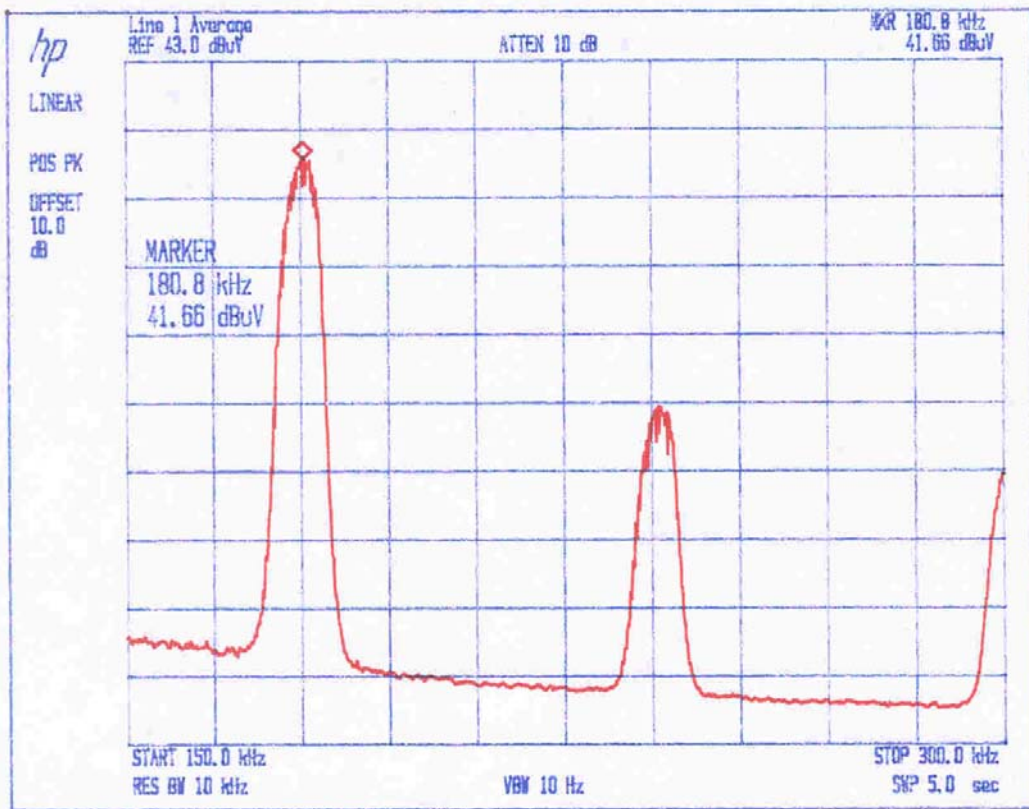

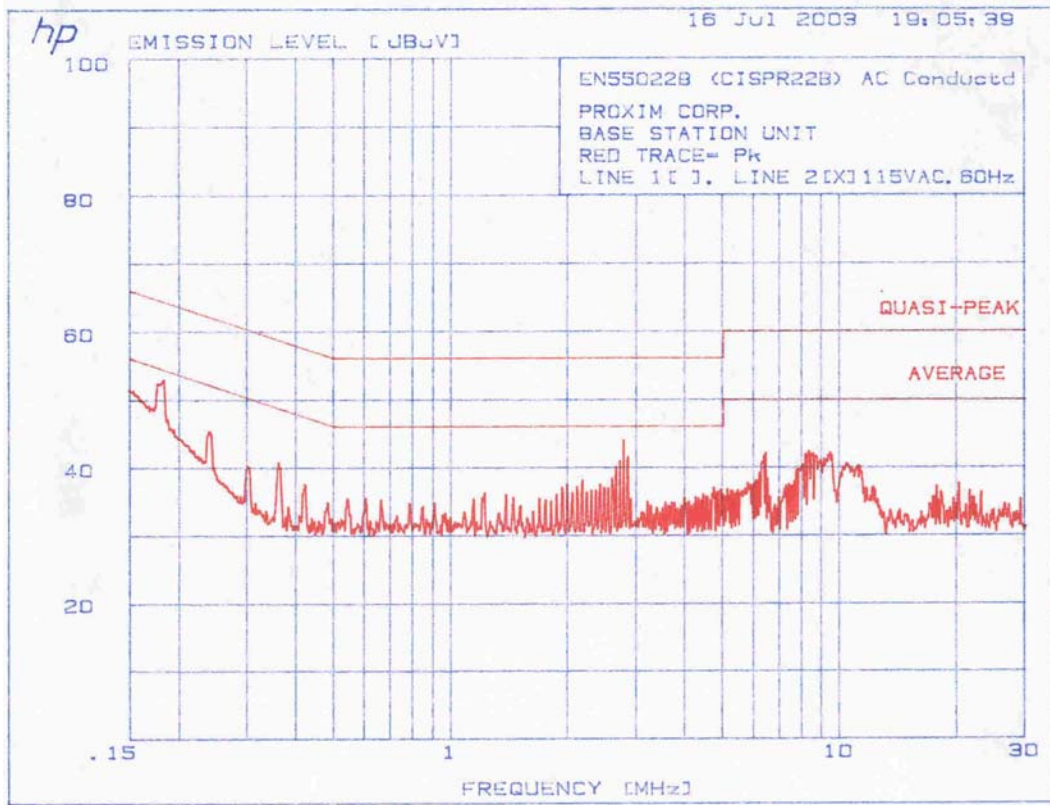

# Intertek ETL SEMKO

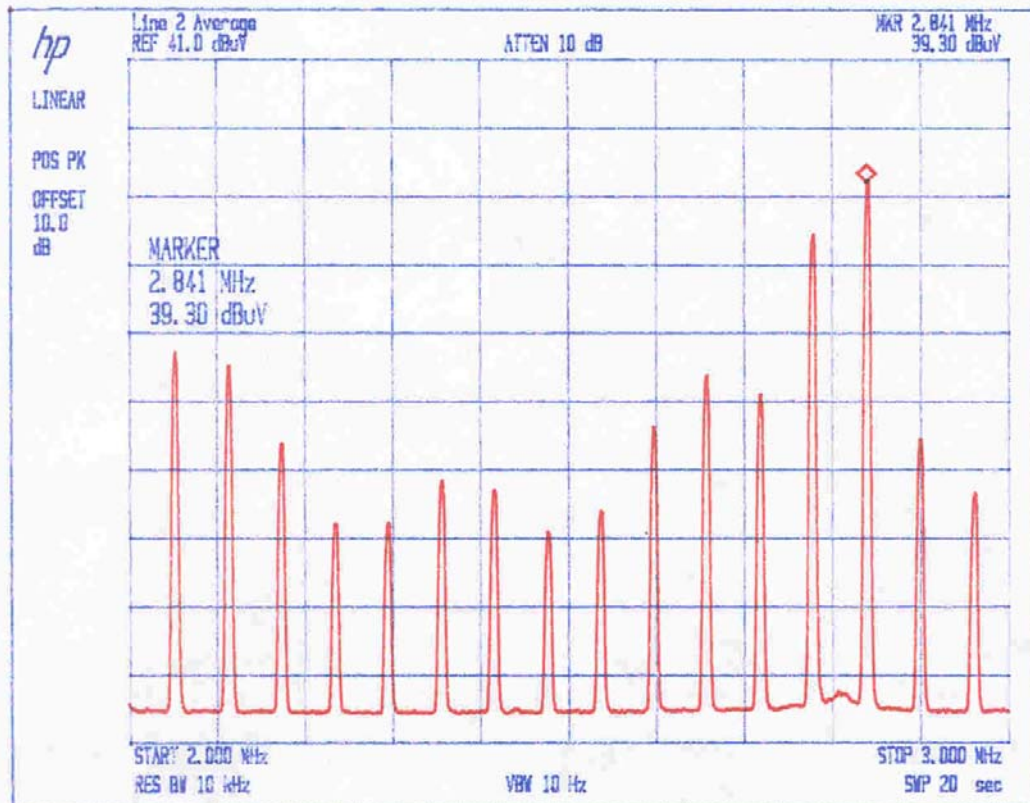
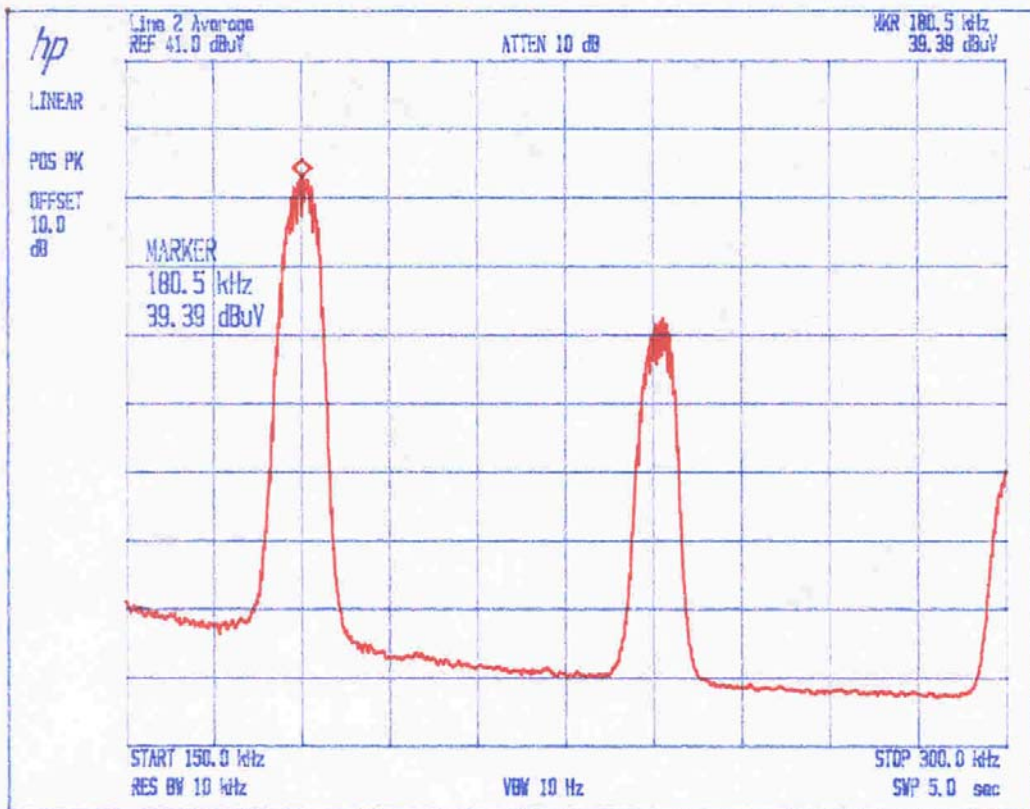

## 5.0 List of Test Equipment

Measurement equipment used for emission compliance testing utilized the equipment on the following list:

EQUIPMENT	MANUFACTURER	MODEL NUMBER	SERIAL NUMBER	CAL. INTERVAL	CAL. DUE
Spectrum Analyzer w/85650 QP Adapter	Hewlett Packard	8566B	2416A00317 2043A00251	12	10/29/03
Spectrum Analyzer w/8650 QP Adapter	Hewlett Packard	8568B	1912A0053 2521A01021	12	11/20/03
Spectrum Analyzer	Hewlett Packard	8565E	AE9674	12	5/27/04
BI-Log Antenna	EMCO	3143	9509-1160	12	9/19/03
Horn Antenna	EMCO	3115	8812-3049	12	4/08/04
Horn Antenna	EMCO	3160-09	Not Labeled	#	#
Horn Antenna	EMCO	3160-10	Not Labeled	#	#
Pre-Amplifier	Miteq	AMF-4D- 001180-24-10P	799159	12	4/06/04
Pre-Amplifier	Avantek	AFT-18855	8723H705	12	4/10/04
Pre-amplifier	CTT	ACO/400	47526	12	4/10/04
LISN	FCC	FCC-LISN-50- 50-M-H	2011	12	2/08/04

# No Calibration required

**6.0 Document History**

<b>Revision/ Job Number</b>	<b>Writer Initials</b>	<b>Date</b>	<b>Change</b>
1.0 / 3044904	DC	October 6, 2003	Original document



**Appendix A – Out-of-band conducted emissions plots**

Plot	Point of measurement	Modulation	Description
4.1a–4.1e	connectorized BSU antenna connector	QAM16	low channel, scan 30 MHz to 40 GHz
4.2a–4.2d	connectorized BSU antenna connector	QAM16	middle channel, scan 30 MHz to 40 GHz
4.3a–4.3d	connectorized BSU antenna connector	QAM16	high channel, scan 30 MHz to 40 GHz
4.4a–4.4b	connectorized BSU antenna connector	QPSK $\frac{3}{4}$	low channel, scan 4 GHz to 5.85 GHz
4.4c–4.4d	connectorized BSU antenna connector	QPSK $\frac{1}{2}$	low channel, scan 4 GHz to 5.85 GHz
4.5a–4.5b	connectorized BSU antenna connector	QPSK $\frac{3}{4}$	high channel, scan 5.725 GHz to 8 GHz
4.5c–4.5d	connectorized BSU antenna connector	QPSK $\frac{1}{2}$	high channel, scan 5.725 GHz to 8 GHz
4.6a–4.6b	integrated BSU RF output	QAM16	low channel, scan 5 GHz to 5.85 GHz
4.6c–4.6d	integrated BSU RF output	QPSK $\frac{3}{4}$	low channel, scan 5 GHz to 5.85 GHz
4.6e–4.6f	integrated BSU RF output	QPSK $\frac{1}{2}$	low channel, scan 5 GHz to 5.85 GHz
4.7a–4.7b	integrated BSU RF output	QAM16	high channel, scan 5.725 GHz to 10 GHz
4.7c–4.7d	integrated BSU RF output	QPSK $\frac{3}{4}$	high channel, scan 5.725 GHz to 10 GHz
4.7e–4.7f	integrated BSU RF output	QPSK $\frac{1}{2}$	high channel, scan 5.725 GHz to 10 GHz