

# ***Measurement Report***

Part 15 Subpart B & C (15.247)

***Product*** .....: ***Wireless USB Dongle Card***  
***Applicant*** .....: ***Proxim Corporation***  
***FCC ID*** .....: ***HZBB11FNFUSB***  
***Model*** .....: ***B11FNF-USB***  
***Report No.*** .....: ***MLT0304P15003***  
***Test Date*** .....: ***May 02.2003***

***Test By***

**Max Light Technology Co.,Ltd.**

*Room 5, 8F, No.125, Section 3 Roosevelt Road,  
Taipei, Taiwan., R.O.C.*

Tel: 886-2-2363-2447 Fax: 886-2-2363-2597

**The test report consists of 69 pages in total. It may be duplicated completely for legal use with the allowance of the applicant. It shall not be reproduced except in full, without the written approval of our laboratory.**



**Table of Contents :**

I. General .....	4.
II. Conducted Emissions Requirements .....	10.
III. Radiated Emissions Requirements .....	18.
IV. Maximum Conducted Output Power Requirements .....	32.
V. Minimum 6dB RF Bandwidth Requirements .....	37.
VI. Maximum Power Density Requirements .....	42.
VII. Out of Band Conducted Emissions Requirements .....	47.
VIII. Band Edges Requirements .....	64.
IX. Processing Gain Requirements .....	66.
X. Antenna Requirements .....	67.
Appendix I (EUT Test Setup) .....	68.



## CERTIFICATION

***We here by verify that :***

The test data, data evaluation, test procedures and equipment configurations shown in this report were made in accordance with the procedures given in ANSI C63.4-1992. All test were conducted by *MLT(Max Light Technology Co.,Ltd) Room 5, 8F, No.125, Section 3 Roosevelt Road, Taipei, Taiwan, R.O.C* Also, we attest to the accuracy of each.

We further submit that the energy emitted by the sample EUT tested as described in the report is in compliance with Class B radiated and conducted emission limit of FCC Rules Part 15 Subpart B & C (15.247).

EUT : Wireless USB Dongle Card

Applicant : Proxim Corporation  
935 Steward Drive, Sunnyvale, CA 94085, USA

Manufacturer : AMBIT MICROSYSTEMS CORPORATION.  
5F-1, 5 Hsin-An Road, Hsinchu  
Science-Based Industrial Park, Taiwan

Model No : B11FNF-USB

FCC ID : HZBB11FNFUSB

Prepared by :  Country Huang  
Approved by :  Roger Chen



## I. GENERAL

### 1.1 Introduction

The following measurement report is submitted on behalf of AMBIT Microsystems Corporation. . In support of a Class B Digital Device certification in accordance with Part2 Subpart J and Part 15 Subpart A And B&C of the Commission's and Regulations.

### 1.2 Description of EUT

EUT : Wireless USB Dongle Card

Applicant : Proxim Corporation  
935 Steward Drive, Sunnyvale, CA 94085, USA

Manufacturer : AMBIT MICROSYSTEMS CORPORATION.  
5F-1, 5 Hsin-An Road, Hsinchu  
Science-Based Industrial Park, Taiwan

Model No : B11FNF-USB

FCC ID : HZBB11FNFUSB

Power Type : Powered by PC

Frequency of Channel: See Next page

Type of Modulation : Direct Sequence Spread Spectrum

Type of Antenna : Printed Antenna

During testing the EUT was operated at Tx or Rx mode for each emission measured. This was done in order to ensure that maximum emission levels were attained.



# MAX LIGHT

## MEASUREMENT REPORT

### Frequency of Each Channel (Working Frequency)

Channel No.	Frequency (MHz)
01	2412
02	2417
03	2422
04	2427
05	2432
06	2437
07	2442
08	2447
09	2452
10	2457
11	2462



### 1.3 Summary Of Tests

47 CFR Part 15 Subpart C			
Reference	Test	Results	Note
15.107	AC Power Conducted Emission	PASS	
15.247(c)	Transmitter Radiated Emissions	PASS	
15.247(b)	Max. Output Power	PASS	
15.247(a)(2)	6dB RF Bandwidth	PASS	
15.247(d)	Max. Power Density	PASS	
15.247(c)	Out of Band Conducted Spurious Emission	PASS	
15.247(c)	Band Edge Measurement	PASS	
15.247(e)	Processing Gain of Direct Sequence	N/A	
15.203	Antenna Requirement	PASS	



#### 1.4 Description of Support Equipment

In order to construct the minimum system which required by the ANSI C63.4-1991, following equipments were used as the support units.

*Computer* : IBM  
Model No. : 16W  
Serial No. : BNC345M  
FCC ID : FCC DOC

*Keyboard* : IBM  
Model No. : KB-9930  
Serial No. : 09N5395  
FCC ID : FCC DOC

*Monitor* : IBM  
Model No. : 10L6145 030  
Serial No. : 23-092079  
FCC ID : FCC DOC

*Mouse* : IBM  
Model No. : 0180-05N  
Serial No. : 23-96142  
FCC ID : EMJMUSJJ

*Printer* : PANASONIC  
Model No. : KX-P1080I  
Serial No. : 7CKAKE98933  
FCC ID : ACJ5Z6KX-P10801  
FCC ID : FCC(DOC)

*Modem* : Askey (External Fax / Data Modem)  
Model No. : WS1414VE  
Serial No. : IAH-10811  
FCC ID : H8N1414VE

### 1.4 Configuration of System Under Test

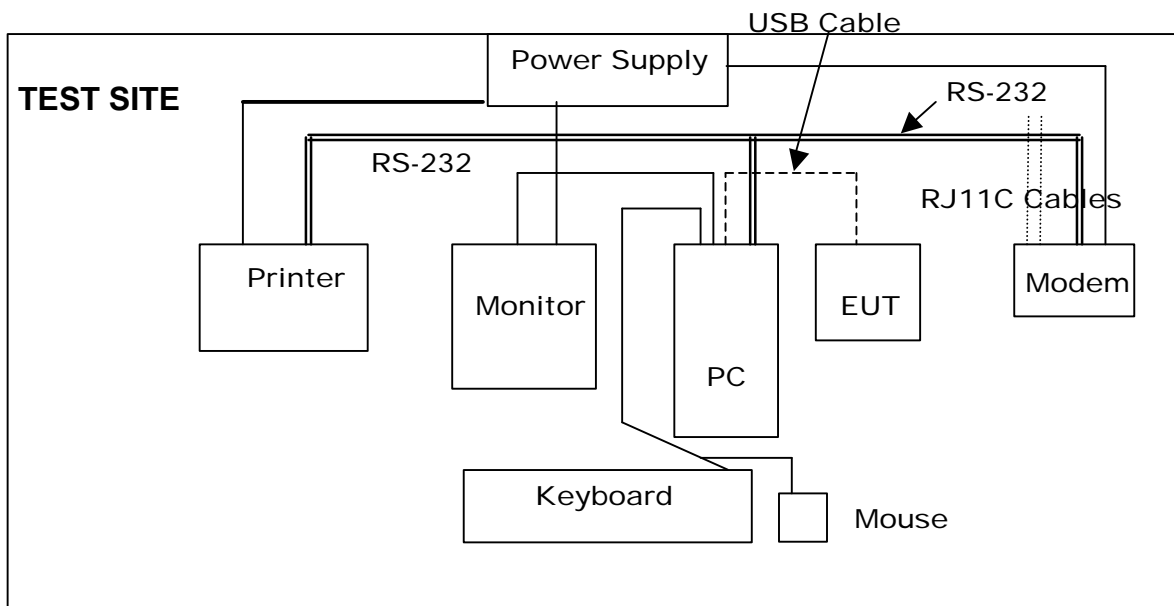

During testing the EUT(USB Wireless)'s USB port connected to the USB port of IBM computer. So there is No need for additional Ethernet card. A mouse was connected to the mouse port of IBM PC. and A keyboard was connected to the mouse port of IBM PC. And a printer was connected to the parallel port. A external modem connected the serial port and the external modem connected with two unterminated telephone cables on the line and phone jack.





## 1.5 Related Submittal / Grant

This submittal is intended for filing for FCC ID:HZBB11FNFUSB

## 1.7 Test Procedure

All measurements contained in this report were performed according to the techniques described in Measurement procedure ANSI C63.4-1992 "Measurement of unIntentional Radiators."

## 1.8 General Test Condition

The conditions under which the EUT operates were varied to determine their effect on the equipment's emission characteristics. The final configuration of the test system and the mode of operation used during these tests was chosen as that which produced the highest emission levels. However, only those conditions which the EUT was considered likely to encounter in normal use were investigated. The system's radiated and conducted emissions were investigated while the computer alternately transferred data to the EUT as well as to the monitor and printer. Using a test program which sent a continuous data and transferred data to and from the EUT was proven to worst case emissions. The system's physical layout and cabling was randomly arranged to ensure that maximum emission levels were attained.



## II. Conducted Emissions Requirements

### 2.1 General & Setup :

The power line conducted emission measurements were performed in a shielded enclosure. The EUT was assembled on a wooden table which is 80 centimeters high, was placed 40 centimeters from the backwall and at least 1 meter from the sidewall.

Power was fed to the EUT from the public utility power grid through a line filter and EMCO Model 3825/2 Line Impedance Stabilization Networks (LISN). The LISN housing, measuring instrumentation case, ground plane, etc., were electrically bonded together at the same RF potential. The Spectrum analyzer was connected to the AC line through an isolation transformer. The 50-ohm output of the LISN was connected to the spectrum analyzer directly. Conducted emission levels were in the CISPER quasi-peak detection mode. The analyzer's 6 dB bandwidth was set to 9 KHz. No post-detector video filter was used.

The spectrum was scanned from 150 KHz to 30 MHz. The physical arrangement of the test system and associated cabling was varied (within the scope of arrangements likely to be encountered in actual use) to determine the effect on the unit's emanations in amplitude and frequency. All spurious emission frequencies were observed. The highest emission amplitudes relative to the appropriate limit were measured and have been recorded in paragraph 2.6.

### 2.2 Test Equipment List:

- A. EMCO 3825/2 LISN (S/N:2654)
- B. EMCO 3825/2 LISN (S/N:2658)
- C. HP 8591EM 9KHZ-1.8GHz Spectrum Analyzer (S/N:73412A00110)
- D. Shielded Room (MLT-SR1)

### 2.3 Test Configuration:



Front View of The Test Configuration

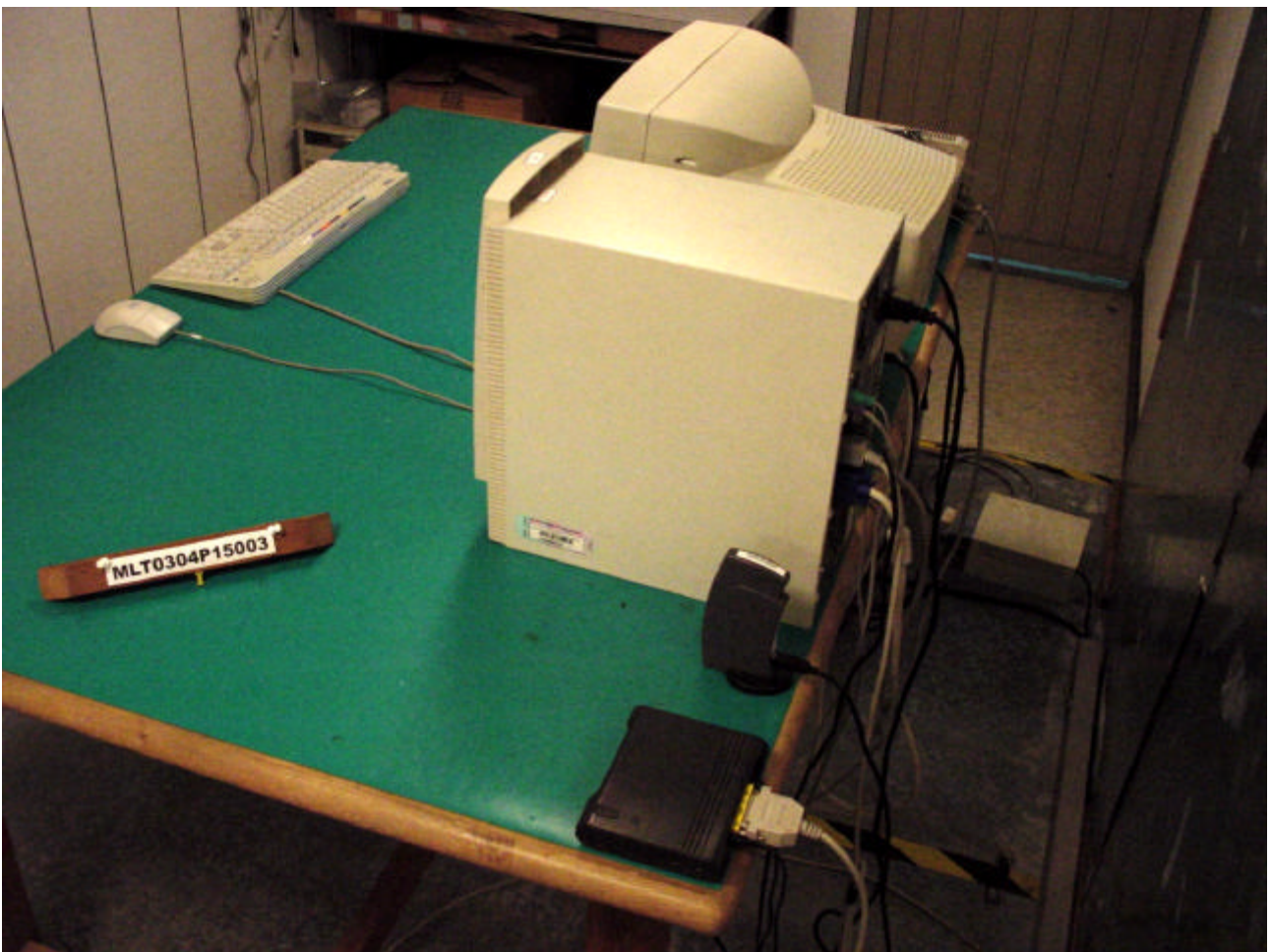

Rear View of The Test Configuration

## 2.4 Test condition:

EUT tested in accordance with the specifications given by the manufacturer , and exercised in the most unfavorable manner.

## 2.5 Conducted Emissions Limits:

<i>Frequency range (MHz)</i>	<i>Limits (dBuV)</i>	
	<i>Quasi-peak</i>	<i>Average</i>
0.15 to 0.50	66 to 56	56 to 46
0.50 to 5.0	56	46
5.0 to 30	60	50

### 2.6 Measurement Data Of Conducted Emissions:

#### 2.6.1 Conducted Emissions (Subpart B)

The following table show a summary of the highest emissions of power line conducted emissions to the HOT and NATURAL conductor of the EUT power.

*Manufacturer* : *AMBIT Microsystems Corporation.*  
*Model No* : *B11FNF-USB*  
*EUT* : *Wireless USB Dongle Card*  
*Test Mode* : *Run "Ping" Command*

Power Line Conducted Emissions (Class B)					
Conductor	Frequency (MHz)	Quasi-Peak (dBuV)	Limits	Average (dBuV)	Limits
L1	0.25	42.76	61	--	51
	0.56	41.54	56	--	46
	0.75	40.95	56	--	46
	0.88	43.98	56	--	46
	0.95	39.54	56	--	46
	0.56	41.54	56	--	46
	18.25	42.21	60	--	50
L2	0.24	41.43	61	--	51
	0.56	42.98	56	--	46
	0.75	42.37	56	--	46
	0.88	40.65	56	--	46
	1.42	40.68	56	--	46
	8.09	41.65	60	--	50
	18.25	42.32	60	--	50

*Notes :*  
 1.L1: One end & Ground L1: The other end & Ground  
 2.Height of table on which the EUT was placed : 0.8 m.  
 3.The Quasi-Peak Value have already met the Average Value Limit showed on above limits.  
 4.The above test results are obtained under the normal condition.

### 2.6.2 Conducted Emissions (Subpart C)

The following table show a summary of the highest emissions of power line conducted emissions to the HOT and NATURAL conductor of the EUT power.

Applicant : Proxim Corporation  
 Model No : B11FNF-USB  
 EUT : Wireless USB Dongle Card  
 Test Mode : Channel No. 1

Power Line Conducted Emissions (Class B)					
Conductor	Frequency (MHz)	Quasi-Peak (dBuV)	Limits	Average (dBuV)	Limits
L1	0.24	41.98	61	--	51
	0.54	40.29	56	--	46
	0.62	39.16	56	--	46
	0.87	42.87	56	--	46
	1.65	41.23	56	--	46
	8.62	39.32	60	--	50
	18.15	42.21	60	--	50
L2	0.24	42.56	61	--	51
	0.54	40.12	56	--	46
	0.62	39.87	56	--	46
	0.87	41.62	56	--	46
	1.65	40.27	56	--	46
	8.62	40.58	60	--	50
	18.15	43.56	60	--	50

- Notes :
- 1.L1: One end & Ground L1: The other end & Ground
  - 2.Height of table on which the EUT was placed : 0.8 m.
  - 3.The Quasi-Peak Value have already met the Average Value Limit showed on above limits.
  - 4.The above test results are obtained under the normal condition.

### 2.6.3 Conducted Emissions (Subpart C)

The following table show a summary of the highest emissions of power line conducted emissions to the HOT and NATURAL conductor of the EUT power.

Applicant : Proxim Corporation  
 Model No : B11FNF-USB  
 EUT : Wireless USB Dongle Card  
 Test Mode : Channel No. 6

Power Line Conducted Emissions (Class B)					
Conductor	Frequency (MHz)	Quasi-Peak (dBuV)	Limits	Average (dBuV)	Limits
L1	0.24	42.12	61	--	51
	0.55	41.30	56	--	46
	0.62	39.88	56	--	46
	0.56	41.85	56	--	46
	1.67	39.29	56	--	46
	8.65	40.88	56	--	46
	18.16	40.12	60	--	50
L2	0.24	42.65	61	--	51
	0.55	42.45	56	--	46
	0.56	42.32	56	--	46
	1.67	39.99	56	--	46
	3.54	37.87	56	--	46
	8.65	41.95	56	--	46
	18.16	39.65	60	--	50

- Notes :
- 1.L1: One end & Ground L1: The other end & Ground
  - 2.Height of table on which the EUT was placed : 0.8 m.
  - 3.The Quasi-Peak Value have already met the Average Value Limit showed on above limits.
  - 4.The above test results are obtained under the normal condition.



### 2.6.4 Conducted Emissions (Subpart C)

The following table show a summary of the highest emissions of power line conducted emissions to the HOT and NATURAL conductor of the EUT power.

*Applicant* : Proxim Corporation  
*Model No* : B11FNF-USB  
*EUT* : Wireless USB Dongle Card  
*Test Mode* : Channel No. 11

Power Line Conducted Emissions (Class B)					
Conductor	Frequency (MHz)	Quasi-Peak (dBuV)	Limits	Average (dBuV)	Limits
L1	0.24	41.58	61	--	51
	0.56	42.65	56	--	46
	0.62	39.86	56	--	46
	0.98	40.90	56	--	46
	1.65	41.24	56	--	46
	8.63	39.89	60	--	50
	14.67	42.26	60	--	50
L2	0.24	40.99	61	--	51
	0.56	41.94	56	--	46
	0.62	39.65	56	--	46
	0.98	40.87	56	--	46
	3.55	39.99	56	--	46
	8.63	39.76	60	--	50
	14.67	40.32	60	--	50

- Notes :
- 1.L1: One end & Ground L1: The other end & Ground
  - 2.Height of table on which the EUT was placed : 0.8 m.
  - 3.The Quasi-Peak Value have already met the Average Value Limit showed on above limits.
  - 4.The above test results are obtained under the normal condition.



### III. Radiated Emissions Requirements

#### 3.1 General Configuration:

Prior to open-field testing, the EUT was placed in a shielded enclosure and scanned at a close distance to determine its emission characteristics. The physical arrangement of the EUT was varied (within the scope of arrangements likely to be encountered in actual use) to determine the effect on the unit's emanations in amplitude, directivity, and frequency. The exact system configuration which produced the highest emissions was noted so it could be reproduced later during the open-field tests. This was done to ensure that the final measurements would demonstrate the worst-case interference potential of the EUT.

#### 3.2 General Configuration:

Final radiation measurements were made on a three-meter, open-field test site. The EUT system was placed on a nonconductive turntable which is 0.8 meters height, top surface 1.0 x 1.5 meter. The spectrum was examined from 250 MHz to 4 GHz in order to cover the whole spectrum below 10th harmonic which could generate from the EUT. During the test, EUT was set to transmit continuously.

A nonconductive material surrounded the EUT to supporting the EUT for standing on three orthogonal planes. At each condition, the EUT was rotated 360 degrees, and the antenna was raised and lowered from one to four meters to find the maximum emission levels. Measurements were taken using both horizontal and vertical antenna polarization.

The field strength below 1 GHz was measured by EMCO Biconilog Antenna (model 3142) at 3 Meter and the SCHWARZBECK Double Ridged Guide Antenna (model BBHA9120D&9170) was used in frequencies 1 - 40 GHz at a distance of 1 meter. All test results were extrapolated to equivalent signal at 3 meters utilizing an inverse linear distance extrapolation Factor (20dB/decade).



Appropriate preamplifiers were used for improving sensitivity and precautions were taken to avoid overloading or desensitizing the spectrum analyzer. No post - detector video filters were used in the test.

The spectrum analyzer's 6 dB bandwidth was set to 1 MHz, and the analyzer was operated in the peak detection mode, for frequencies both below and up 1 GHz. The average levels were obtained by subtracting the duty cycle correction factor from the peak readings.

The following procedures were used to convert the emission levels measured in decibels referenced to 1 microvolt (dBuV) into field intensity in microvolts per meter (uV/m).

The actual field intensity in decibels referenced to 1 microvolt in to field intensity in microvolts per meter (dBuV/m).

The actual field intensity in referenced to 1 microvolt per meter (dBuV/m) is determined by algebraically adding the measured reading in dBuV, the antenna factor (dB), and cable loss (dB) and Subtracting the gain of preamplifier (dB) is auto calculate in spectrum analyzer.

$$(1) \text{ Amplitude (dBuV/m)} = \text{FI(dBuV)} + \text{AF(dBuV)} + \text{CL(dBuV)} - \text{Gain(dB)}$$

FI= Reading of the field intensity.

AF= Antenna factor.

CL= Cable loss.

*P.S Amplitude is auto calculate in spectrum analyzer.*

$$(2) \text{ Actual Amplitude (dBuV/m)} = \text{Amplitude (dBuV)} - \text{Dis(dB)}$$

The FCC specified emission limits were calculated according the EUT operating frequency and by following linear interpolation equations:

(1) For fundamental frequency :

Transmitter Output < +30dBm

(2) For spurious frequency :

Spurious emission limits = fundamental emission limit /10



### 3.2 Test Equipment List:

- A. HP 8591EM 9KHz-1.8GHz Spectrum Analyzer (S/N:73412A00230)
- B. HP 8447D Pre Amplifier (S/N:2944A08954)
- C. Agilent E4407B 9KHz-26.5GHz Spectrum Analyzer (S/N:A872JS02291)
- D. HP 8449B Pre Amplifier (S/N:1982901A91)
- E. SCHWARZBECK BBHA 9120D Biconilog Antenna (S/N:141S3)
- F. SCHWARZBECK BBHA 9170 Biconilog Antenna (S/N:192S5)

### 3.3 Test Configuration:



Front View of The Test Configuration



Rear View of The Test Configuration



### 3.4 Test condition:

EUT tested in accordance with the specifications given by the manufacturer , and exercised in the most unfavorable manner.

### 3.5 Radiated Emissions Limits:

<i>Frequency range (MHz)</i>	<i>Peak(dBuV)</i>
30 to 88	40
88 to 216	43.5
216 to 960	46
Above 960	54



### 3.6 Measurement Data Of Radiated Emissions:

#### 3.6.1 Open Field Radiated Emissions (Subpart B)

The highest peak values of radiated emissions from the EUT at various antenna heights, antenna polarization, EUT orientation , etc. are recorded on the following

*Applicant* : Proxim Corporation  
*Model No* : B11FNF-USB  
*EUT* : Wireless USB Dongle Card  
*Test Mode* : Run "Ping" Command

Radiated Emissions (HORIZONTAL)					
Frequency (MHz)	Amplitude (dBuV/m)	Ant. (m)	Table (Degree)	Limits(Class B) (dBuV/m)	Margin (dB)
60.45	33.83	2	270	40	-6.17
108.72	30.23	2.5	310	43.5	-13.27
121.97	35.67	4	140	43.5	-7.83
176.38	33.23	2	20	43.5	-10.27
189.56	34.67	3	360	43.5	-8.83
197.78	33.45	3.5	290	43.5	-10.05
212.34	31.82	1	340	43.5	-11.68
302.62	34.56	2.5	170	46	-11.44
504.12	38.78	2	360	46	-7.22
594.41	35.56	1.5	320	46	-10.44
645.65	37.09	4	270	46	-8.91

- Notes :
- 1.Margin= Amplitude - Limits
  - 2.Distance of Measurement : 3 Meter (30-1000MHz)
  - 3.Height of table for EUT placed: 0.8 Meter.
  - 4.ANT= Antenna height.
  - 5.Amplitude= Reading Amplitude -Amplifier gain+Cable loss +Antenna factor  
(Auto calculate in spectrum analyzer)





3.6.2 Open Field Radiated Emissions (Subpart B)

The highest peak values of radiated emissions from the EUT at various antenna heights, antenna polarization, EUT orientation , etc. are recorded on the following.

Applicant : Proxim Corporation  
Model No : B11FNF-USB  
EUT : Wireless USB Dongle Card  
Test Mode : Run "Ping" Command

Radiated Emissions (VERTICAL)					
Frequency (MHz)	Amplitude (dBuV/m)	Ant. (m)	Table (Degree)	Limits(Class B) (dBuV/m)	Margin (dB)
60.45	36.89	1	260	40	-3.11
108.72	32.57	1.5	320	40	-7.43
121.97	34.09	2	250	43.5	-9.41
176.38	37.98	1.5	340	43.5	-5.52
189.56	32.45	1	120	43.5	-11.05
197.78	37.99	1.5	320	43.5	-5.51
212.34	34.56	1.5	360	43.5	-8.94
302.62	37.83	2	240	46	-8.17
504.12	39.43	1.5	290	46	-6.57
594.41	36.67	1.5	360	46	-9.33
645.65	39.92	1	120	46	-6.08

- Notes :
- 1.Margin= Amplitude - Limits
  - 2.Distance of Measurement : 3 Meter (30-1000MHz)
  - 3.Height of table for EUT placed: 0.8 Meter.
  - 4.ANT= Antenna height.
  - 5.Amplitude= Reading Amplitude -Amplifier gain+Cable loss +Antenna factor  
(Auto calculate in spectrum analyzer)



3.6.3 Open Field Radiated Emissions (Subpart C)

The highest peak values of radiated emissions from the EUT at various antenna heights, antenna polarization, EUT orientation , etc. are recorded on the following

*Applicant* : Proxim Corporation  
*Model No* : B11FNF-USB  
*EUT* : Wireless USB Dongle Card  
*Test Mode* : Channel No. 1

Radiated Emissions (HORIZONTAL)								
Frequency (MHz)	Amplitude (dBuV/m)	Ant. (m)	Table (Degree)	Duty (dB)	Dist (dB)	Actual Amp (dBuV/m)	Limit (dBuV/m)	Margin (dB)
1043.21	56.23	1	340	0	9.54	46.69	74.00	-27.31
4824.11	60.24	1	280	0	9.54	50.70	74.00	-23.30
4835.54	61.56	1	10	0	9.54	52.02	74.00	-21.98
7244.00	57.73	1	180	0	9.54	48.19	74.00	-25.81
9648.65	58.34	1	360	0	9.54	48.80	74.00	-25.20
12059.88	57.34	1	220	0	9.54	47.80	74.00	-26.20
14472.24	55.90	1	210	0	9.54	46.36	74.00	-27.64

- Notes :
- 1.Margin= Amplitude - Limits
  - 2.Distance of Measurement : 3 Meter (30-1000MHz)
  - 3.Height of table for EUT placed: 0.8 Meter.
  - 4.ANT= Antenna height.
  - 5.Duty= Duty cycle correction factor.
  - 6.Dis= Distance extrapolation factor.
  - 7.Amplitude= Reading Amplitude - Amplifier gain+Cable loss +Antenna factor  
(Auto calculate in spectrum analyzer)
  - 8.Actual Amp= Amplitude - Duty - Dis.



3.6.4 Open Field Radiated Emissions (Subpart C)

The highest peak values of radiated emissions from the EUT at various antenna heights, antenna polarization, EUT orientation , etc. are recorded on the following.

Applicant : Proxim Corporation  
Model No : B11FNF-USB  
EUT : Wireless USB Dongle Card  
Test Mode : Channel No. 1

Radiated Emissions (VERTICAL)								
Frequency (MHz)	Amplitude (dBuV/m)	Ant. (m)	Table (Degree)	Duty (dB)	Dist (dB)	Actual Amp (dBuV/m)	Limit (dBuV/m)	Margin (dB)
1043.21	55.45	1.1	210	0	9.54	45.91	74.00	-28.09
4824.11	58.34	1	360	0	9.54	48.80	74.00	-25.20
4835.54	59.24	1.1	210	0	9.54	49.70	74.00	-24.30
7244.00	56.23	1	290	0	9.54	46.69	74.00	-27.31
9648.65	56.67	1	190	0	9.54	47.13	74.00	-26.87
12059.88	55.47	1	360	0	9.54	45.93	74.00	-28.07
14472.24	56.88	1	290	0	9.54	47.34	74.00	-26.66

- Notes :
- 1. Margin= Amplitude - Limits
  - 2. Distance of Measurement : 3 Meter (30-1000MHz)
  - 3. Height of table for EUT placed: 0.8 Meter.
  - 4. ANT= Antenna height.
  - 5. Duty= Duty cycle correction factor.
  - 6. Dis= Distance extrapolation factor.
  - 7. Amplitude= Reading Amplitude - Amplifier gain+Cable loss +Antenna factor  
(Auto calculate in spectrum analyzer)
  - 8. Actual Amp= Amplitude - Duty - Dis.



3.6.5 Open Field Radiated Emissions (Subpart C)

The highest peak values of radiated emissions from the EUT at various antenna heights, antenna polarization, EUT orientation , etc. are recorded on the following

Applicant : Proxim Corporation  
Model No : B11FNF-USB  
EUT : Wireless USB Dongle Card  
Test Mode : Channel No. 6

Radiated Emissions (HORIZONTAL)								
Frequency (MHz)	Amplitude (dBuV/m)	Ant. (m)	Table (Degree)	Duty (dB)	Dist (dB)	Actual Amp (dBuV/m)	Limit (dBuV/m)	Margin (dB)
1092.03	54.21	1	210	0	9.54	44.67	74.00	-29.33
4832.34	60.88	1	320	0	9.54	51.34	74.00	-22.66
4874.35	62.56	1	360	0	9.54	53.02	74.00	-20.98
7244.79	59.73	1	190	0	9.54	50.19	74.00	-23.81
9748.51	58.21	1	210	0	9.54	48.67	74.00	-25.33
12186.23	57.98	1	330	0	9.54	48.44	74.00	-25.56
14620.79	55.85	1	290	0	9.54	46.31	74.00	-27.69

- Notes :
- 1.Margin= Amplitude - Limits
  - 2.Distance of Measurement : 3 Meter (30-1000MHz)
  - 3.Height of table for EUT placed: 0.8 Meter.
  - 4.ANT= Antenna height.
  - 5.Duty= Duty cycle correction factor.
  - 6.Dis= Distance extrapolation factor.
  - 7.Amplitude= Reading Amplitude - Amplifier gain+Cable loss +Antenna factor  
(Auto calculate in spectrum analyzer)
  - 8.Actual Amp= Amplitude - Duty - Dis.



3.6.6 Open Field Radiated Emissions (Subpart C)

The highest peak values of radiated emissions from the EUT at various antenna heights, antenna polarization, EUT orientation , etc. are recorded on the following.

Applicant : Proxim Corporation  
Model No : B11FNF-USB  
EUT : Wireless USB Dongle Card  
Test Mode : Channel No. 6

Radiated Emissions (VERTICAL)								
Frequency (MHz)	Amplitude (dBuV/m)	Ant. (m)	Table (Degree)	Duty (dB)	Dist (dB)	Actual Amp (dBuV/m)	Limit (dBuV/m)	Margin (dB)
1092.03	53.98	1	220	0	9.54	44.44	74.00	-29.56
4832.34	58.45	1.1	190	0	9.54	48.91	74.00	-25.09
4874.35	60.27	1	340	0	9.54	50.73	74.00	-23.27
7244.79	57.23	1	290	0	9.54	47.69	74.00	-26.31
9748.51	58.01	1	120	0	9.54	48.47	74.00	-25.53
12186.23	56.68	1	360	0	9.54	47.14	74.00	-26.86
14620.79	55.03	1	320	0	9.54	45.49	74.00	-28.51

- Notes :
- 1.Margin= Amplitude - Limits
  - 2.Distance of Measurement : 3 Meter (30-1000MHz)
  - 3.Height of table for EUT placed: 0.8 Meter.
  - 4.ANT= Antenna height.
  - 5.Duty= Duty cycle correction factor.
  - 6.Dis= Distance extrapolation factor.
  - 7.Amplitude= Reading Amplitude - Amplifier gain+Cable loss +Antenna factor  
(Auto calculate in spectrum analyzer)
  - 8.Actual Amp= Amplitude - Duty - Dis.



3.6.7 Open Field Radiated Emissions (Subpart C)

The highest peak values of radiated emissions from the EUT at various antenna heights, antenna polarization, EUT orientation , etc. are recorded on the following

*Applicant* : Proxim Corporation  
*Model No* : B11FNF-USB  
*EUT* : Wireless USB Dongle Card  
*Test Mode* : Channel No. 11

Radiated Emissions (HORIZONTAL)								
Frequency (MHz)	Amplitude (dBuV/m)	Ant. (m)	Table (Degree)	Duty (dB)	Dist (dB)	Actual Amp (dBuV/m)	Limit (dBuV/m)	Margin (dB)
1092.25	54.23	1.1	360	0	9.54	44.69	74.00	-29.31
4832.61	61.89	1	220	0	9.54	52.35	74.00	-21.65
4924.89	58.87	1	360	0	9.54	49.33	74.00	-24.67
7244.91	57.55	1	290	0	9.54	48.01	74.00	-25.99
9847.56	55.12	1	320	0	9.54	45.58	74.00	-28.42
12310.27	56.04	1	190	0	9.54	46.50	74.00	-27.50
14772.21	56.12	1	350	0	9.54	46.58	74.00	-27.42

- Notes :
- 1.Margin= Amplitude - Limits
  - 2.Distance of Measurement : 3 Meter (30-1000MHz)
  - 3.Height of table for EUT placed: 0.8 Meter.
  - 4.ANT= Antenna height.
  - 5.Duty= Duty cycle correction factor.
  - 6.Dis= Distance extrapolation factor.
  - 7.Amplitude= Reading Amplitude - Amplifier gain+Cable loss +Antenna factor  
(Auto calculate in spectrum analyzer)
  - 8.Actual Amp= Amplitude - Duty - Dis.



3.6.8 Open Field Radiated Emissions (Subpart C)

The highest peak values of radiated emissions from the EUT at various antenna heights, antenna polarization, EUT orientation , etc. are recorded on the following.

Applicant : Proxim Corporation  
Model No : B11FNF-USB  
EUT : Wireless USB Dongle Card  
Test Mode : Channel No. 11

Radiated Emissions (VERTICAL)								
Frequency (MHz)	Amplitude (dBuV/m)	Ant. (m)	Table (Degree)	Duty (dB)	Dist (dB)	Actual Amp (dBuV/m)	Limit (dBuV/m)	Margin (dB)
1092.25	53.56	1	250	0	9.54	44.02	74.00	-29.98
4832.61	60.76	1	360	0	9.54	51.22	74.00	-22.78
4924.89	57.43	1	80	0	9.54	47.89	74.00	-26.11
7244.91	56.12	1	180	0	9.54	46.58	74.00	-27.42
9847.56	55.09	1	340	0	9.54	45.55	74.00	-28.45
12310.27	55.56	1	290	0	9.54	46.02	74.00	-27.98
14772.21	58.23	1	300	0	9.54	48.69	74.00	-25.31

- Notes :
- 1.Margin= Amplitude - Limits
  - 2.Distance of Measurement : 3 Meter (30-1000MHz)
  - 3.Height of table for EUT placed: 0.8 Meter.
  - 4.ANT= Antenna height.
  - 5.Duty= Duty cycle correction factor.
  - 6.Dis= Distance extrapolation factor.
  - 7.Amplitude= Reading Amplitude - Amplifier gain+Cable loss +Antenna factor  
(Auto calculate in spectrum analyzer)
  - 8.Actual Amp= Amplitude - Duty - Dis.



## IV. Maximum Conducted Output Power Requirements

### 4.1 Test Condition & Setup :

The tests below are run with the EUT's transmitter set at high power in TDD mode. A RJ-45 port from a computer to the EUT is needed to force selection of output power level and channel number. While testing, EUT was set to transmit continuously. Remove the Subjective device's antenna and connect the RF output port to spectrum analyzer. The maximum peak output power shall not exceed 1 watt.

Use a direct connection between the antenna port of transmitter and the spectrum Analyzer, for prevent the spectrum analyzer input attenuation 40-50 dB. Set the RBW Bandwidth of the emission or use a channel power meter mode .

For antennas with gains of 6 dBi or less , maximum allowed transmitter output is 1 watt (+30 dBm). For antennas with gains greater than 6 dBi, transmitter output level must be decreased by an amount equal to  $(GAIN - 6)/3$  dBm.

The antenna port of the EUT was connected to the input of a power meter. Power was read directly and cable loss correction was added to the reading to obtain power at the EUT antenna terminals.



#### 4.2 Test Instruments Configuration:

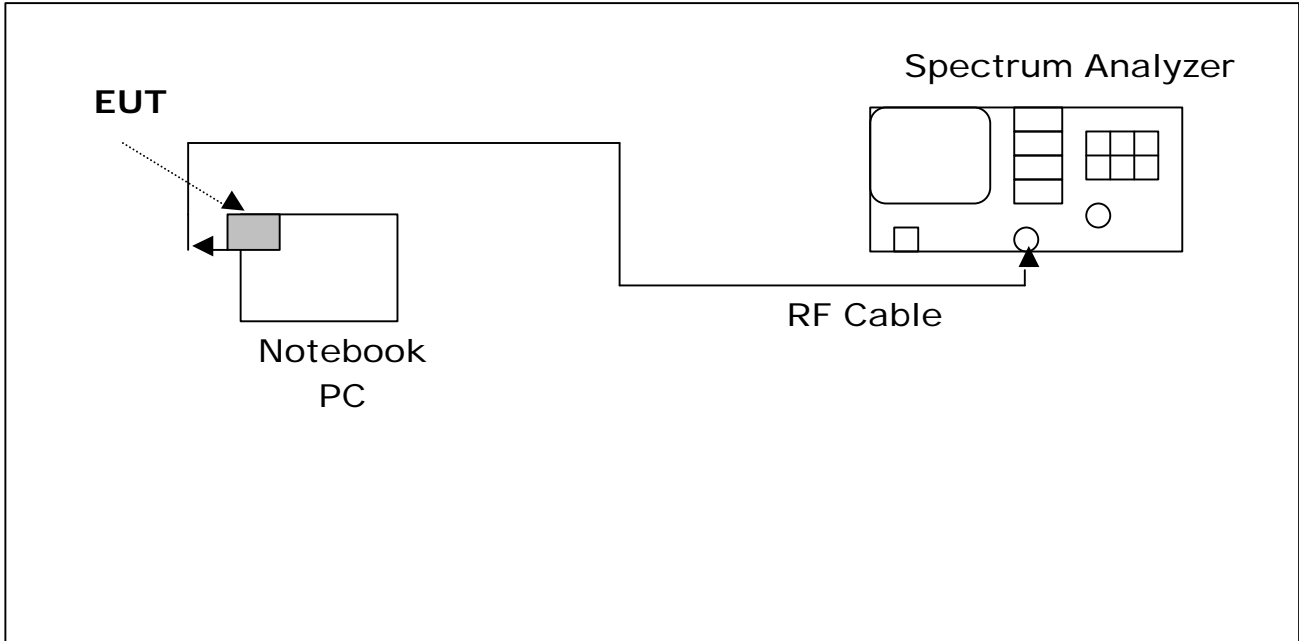

#### 4.3 Test Equipment List:

- A. Agilent E4407B 9KHz-26.5GHz Spectrum Analyzer (S/N:A872JS02291)
- B. HP 8449B Pre Amplifier (S/N:1982901A91)
- E. Shielded Room (MLT-SR1)

#### 4.4 Test Result:

Frequency (MHz)	Output(dBm)	Required Limit
2412	15.03	<30dBm
2437	16.03	<30dBm
2462	15.06	<30dBm

Note :Test Graphs See next page.

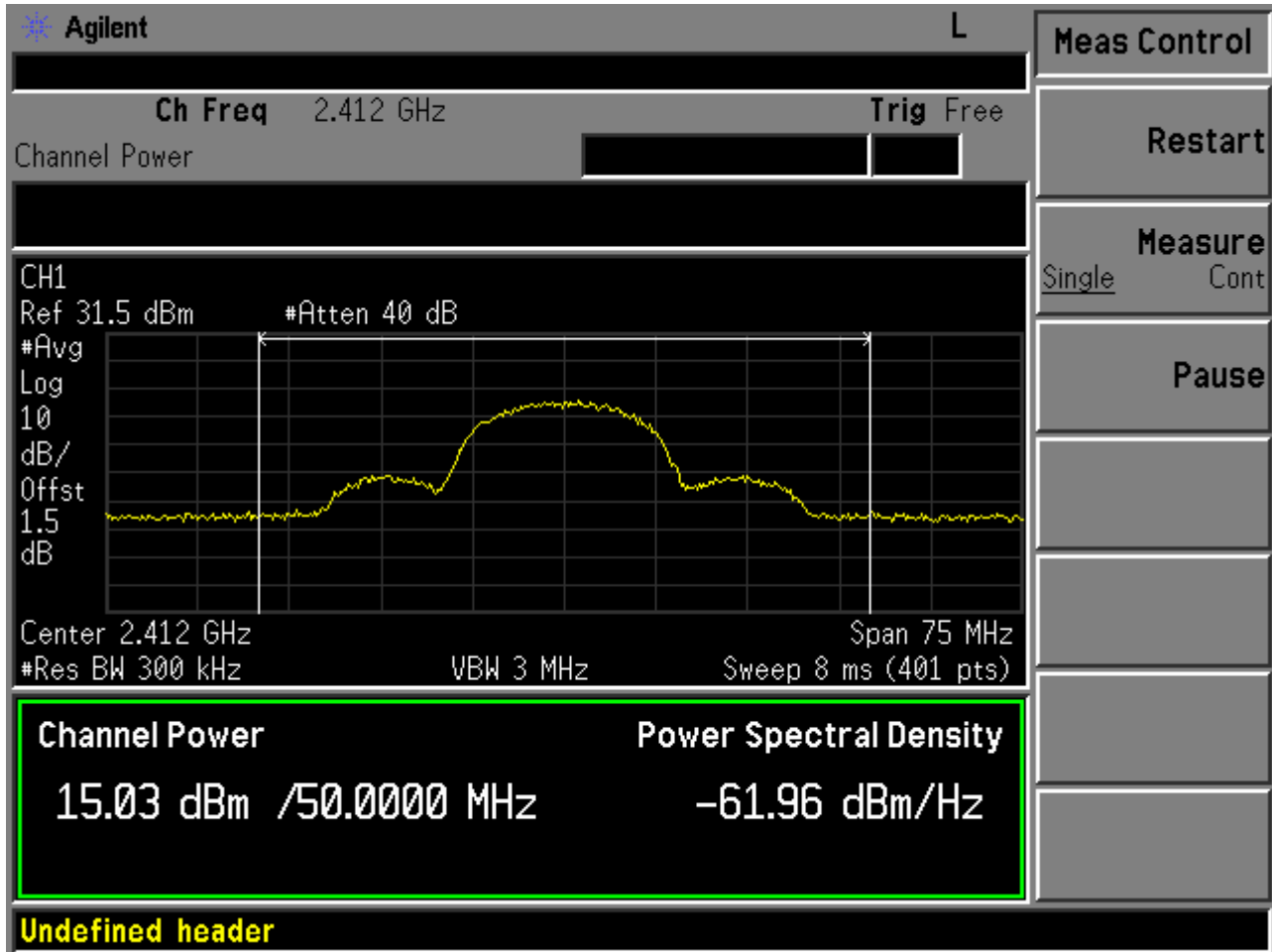

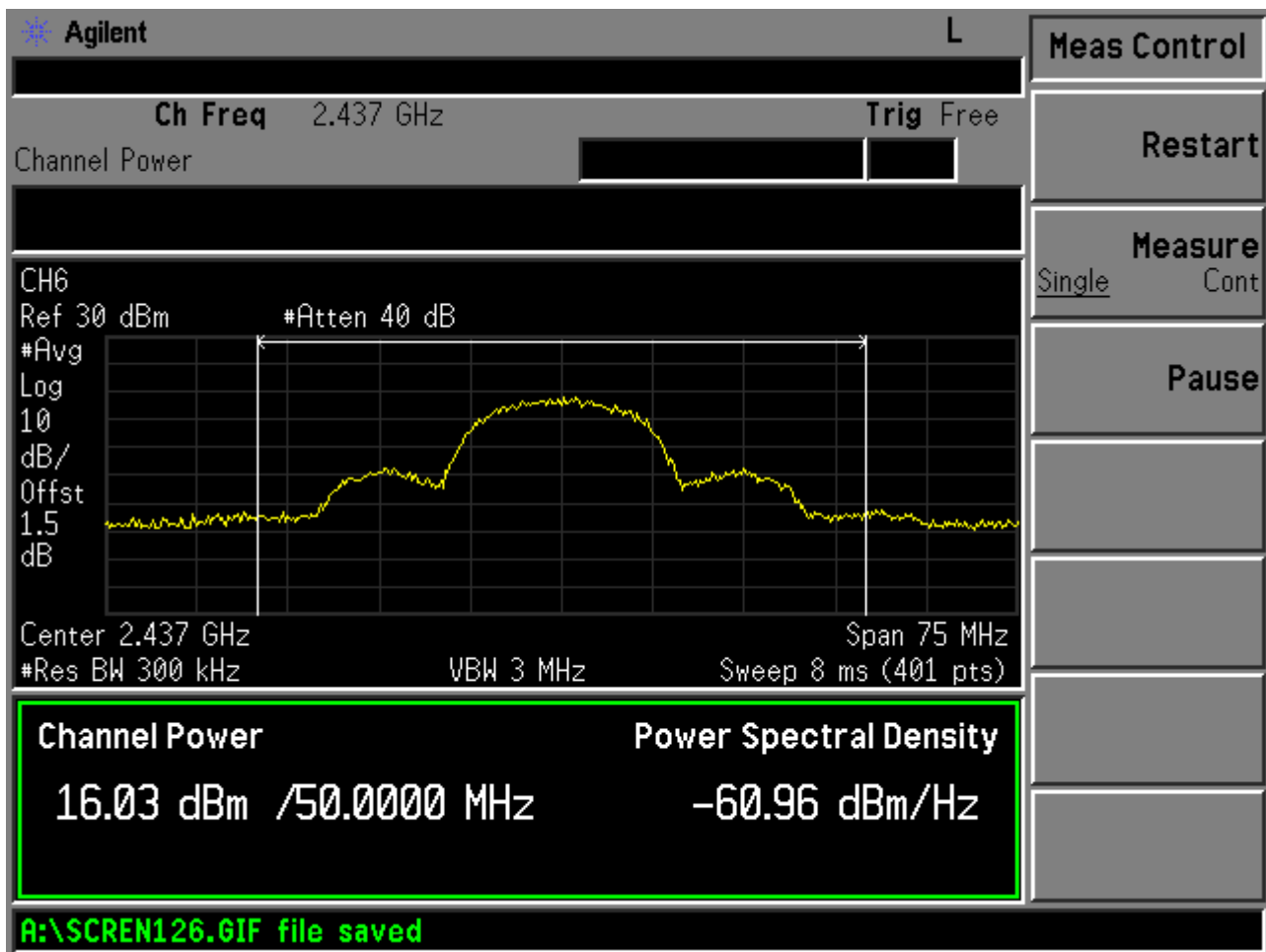

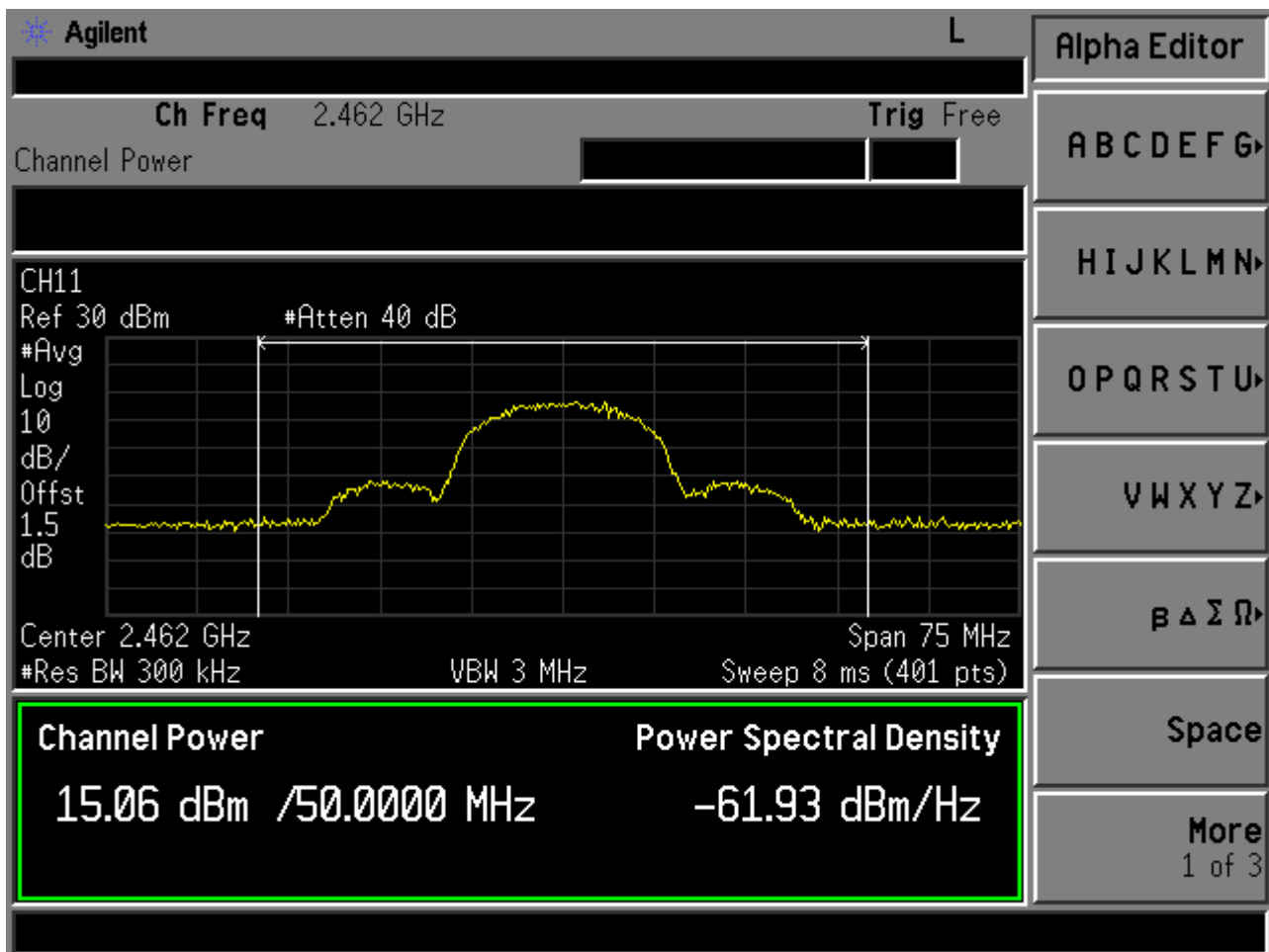

## V. Minimum 6dB RF Bandwidth Requirements

### 5.1 Test Condition & Setup :

The antenna port of the EUT was connected to the input of a spectrum analyzer. Analyzer RES BW was set to 100 kHz. For each RF output channel investigated, the spectrum analyzer center frequency was set to the channel carrier. A PEAK output reading was taken, a DISPLAY line was drawn 6 dB lower than PEAK level. The 6 dB bandwidth was determined from where the channel output spectrum intersected the display line.

The test was performed at 3 channels (Channel 1, 6,11)

### 5.2 Test Instruments Configuration:

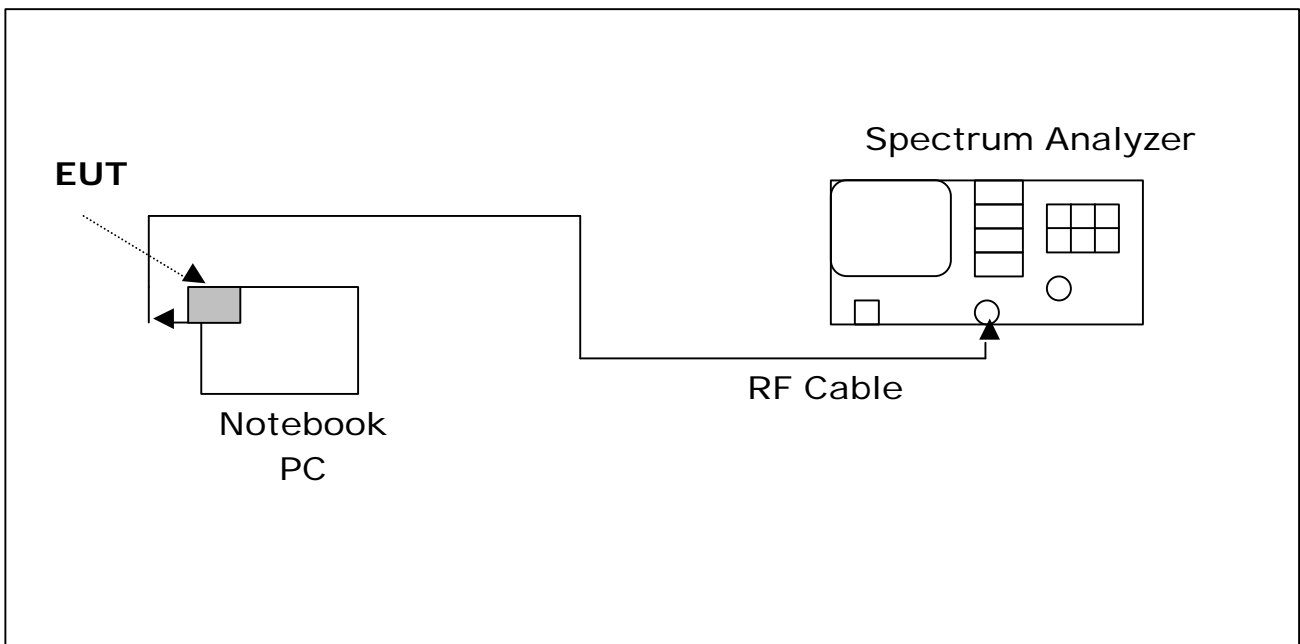



### 5.3 Test Equipment List:

- A. Agilent E4407B 9KHz-26.5GHz Spectrum Analyzer (S/N:A872JS02291)
- B. HP 8449B Pre Amplifier (S/N:1982901A91)
- E. Shielded Room (MLT-SR1)

### 5.4 Test Result:

Frequency (MHz)	Min. 6dB Bandwidth (MHz)	Required Limit
2412	11.20	>500KHz
2437	10.50	>500KHz
2462	11.70	>500KHz

*Note :Test Graphs See next page.*



# MAX LIGHT

MEASUREMENT REPORT

CH1 Apr 21 11:13:48  
REF 15.5 dBm \*ATT 40dB A\_max B\_view  
10dB/ Posi Posi

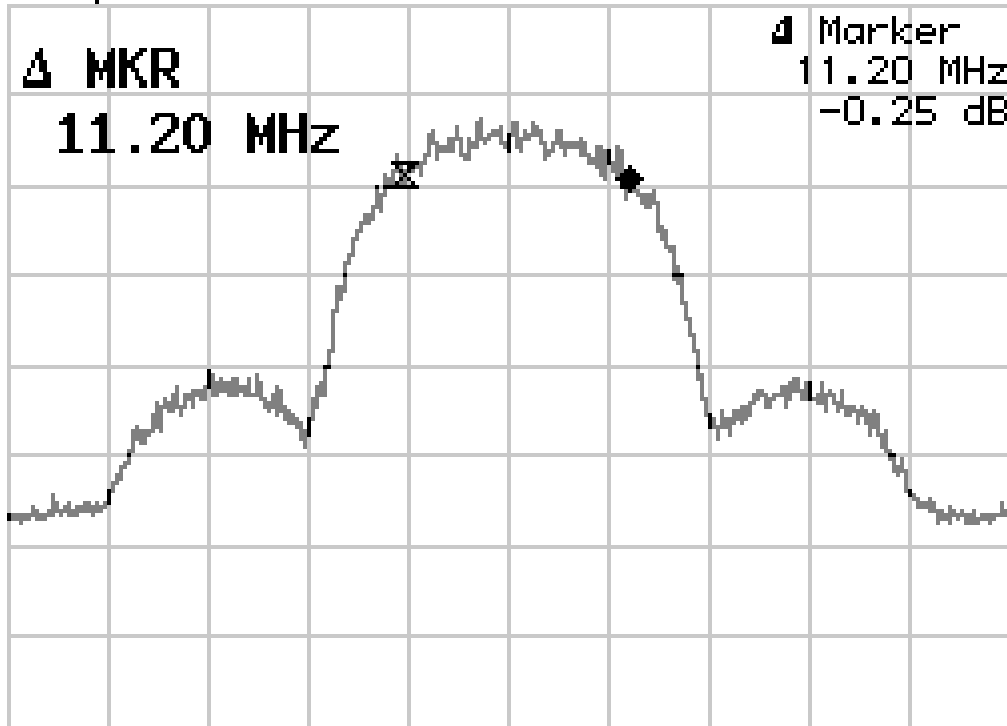

- Marker(1)

---

- Normal Marker

---

- Delta Marker

---

- Peak Menu ▶

---

- Sig Track ON /OFF

---

- Sound ▶

---

- Marker Off

---

CENTER 2.41200 GHz SPAN 50.0 MHz  
\*RBW 100 kHz \*VBW 100 kHz \*SWP 100 ms

1/2, more▶



# MAX LIGHT

## MEASUREMENT REPORT

CH6

Apr 21 11:19:32

REF 15.5 dBm  
10dB/

\*ATT 40dB A\_max B\_view  
Posi Posi

- Marker(1)

---

- Normal Marker

---

- Delta Marker

---

- Peak Menu ▶

---

- Sig Track ON /OFF

---

- Sound ▶

---

- Marker Off

---

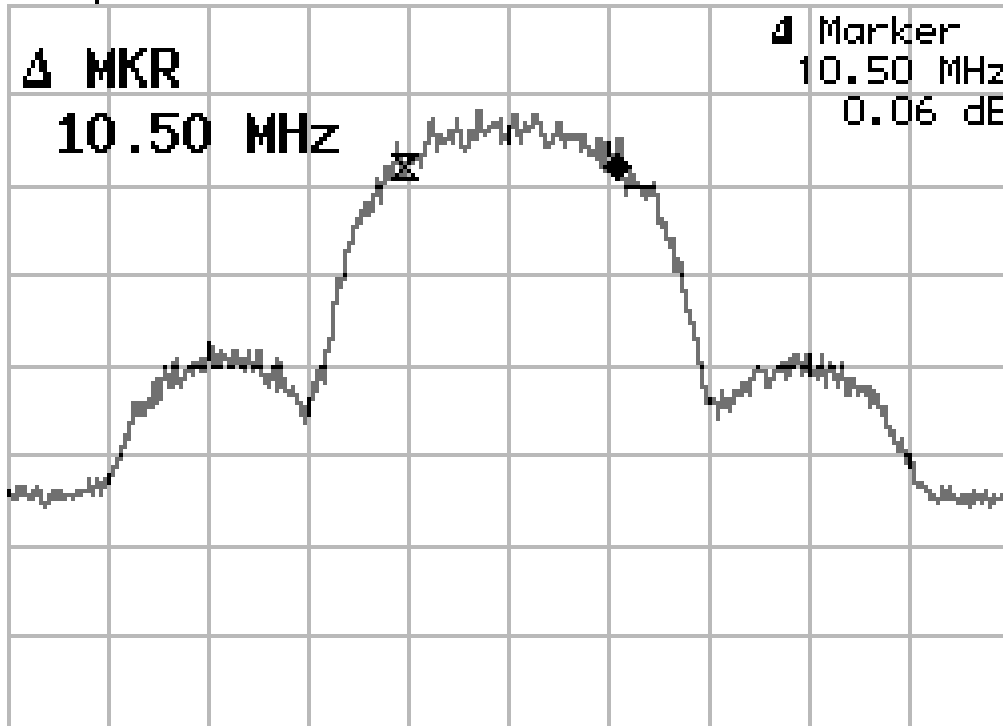
CENTER 2.43700 GHz SPAN 50.0 MHz  
\*RBW 100 kHz \*VBW 100 kHz \*SWP 100 ms

1/2, more ▶





# MAX LIGHT

MEASUREMENT REPORT

CH11

Apr 21 11:24:17

REF 15.5 dBm  
10dB/

\*ATT 40dB A\_max B\_view  
Posi Posi

Marker(1)

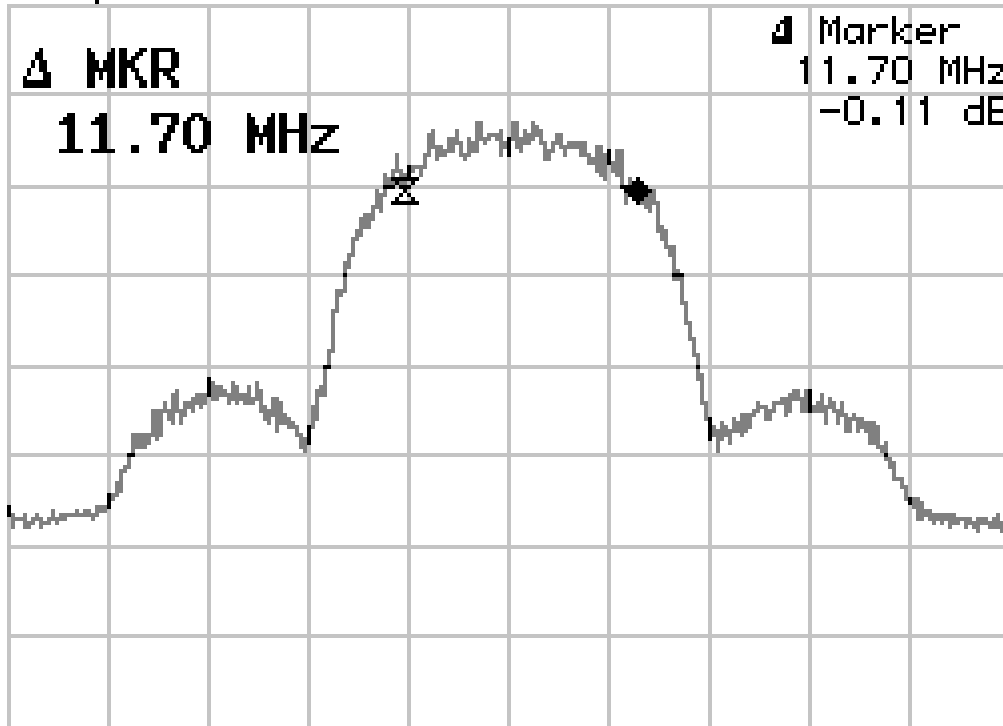

Normal  
Marker

Delta  
Marker

Peak  
Menu ▶

Sig Track  
ON /OFF

Sound ▶

Marker  
Off

CENTER 2.46200 GHz SPAN 50.0 MHz  
\*RBW 100 kHz \*VBW 100 kHz \*SWP 100 ms

1/2,more▶

## VI. Maximum Power Density Requirements

### 6.1 Test Condition & Setup :

The spectrum analyzer RES BW was set to 3 kHz. The START and STOP frequencies were set to the band edges of the maximum output passband. If there is no clear maximum amplitude in any given portion of the band, it may be necessary to make measurements at a number of bands defined by several START and STOP frequency pairs. The specification calls for a 1 second interval at each 3 kHz bandwidth; total SWEEP TIME is calculated as follows:

$$\text{SWEEP TIME (SEC)} = (\text{Fstop, kHz} - \text{Fstart, kHz}) / 3 \text{ kHz}$$

Antenna output of the EUT was coupled directly to spectrum analyzer; if an external attenuator and/or cable was used, these losses are compensated for with the analyzer OFFSET function.

### 6.2 Test Instruments Configuration:

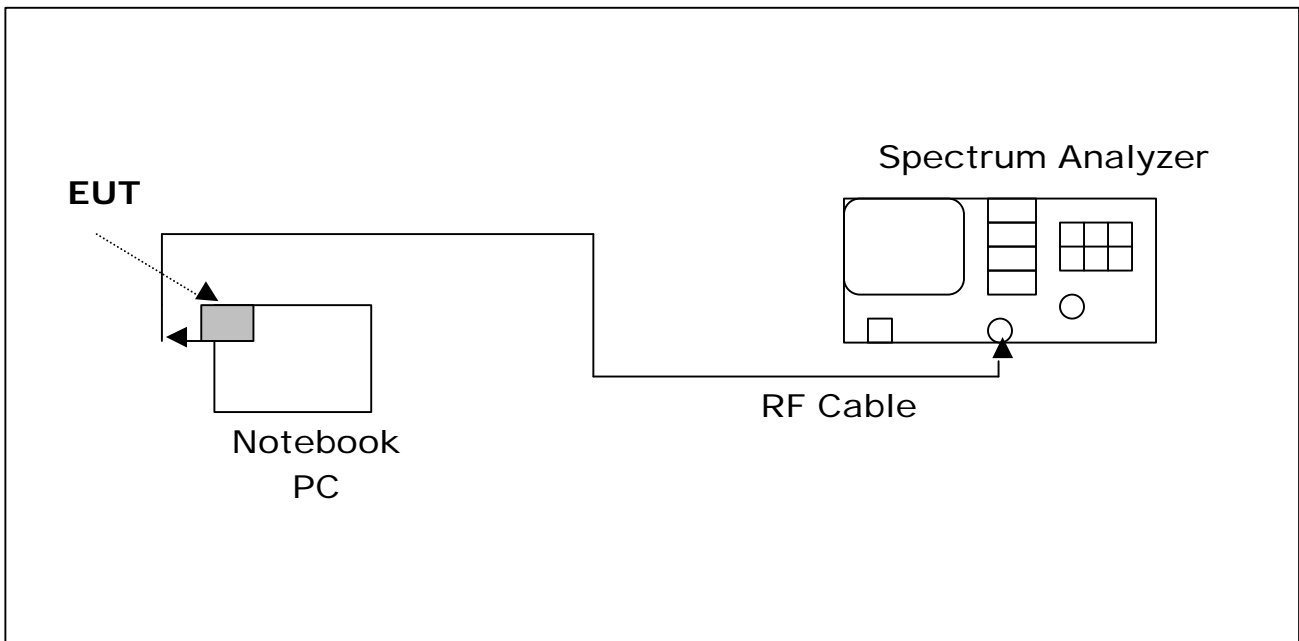



### 6.3 Test Equipment List:

- A. Agilent E4407B 9KHz-26.5GHz Spectrum Analyzer (S/N:A872JS02291)
- B. HP 8449B Pre Amplifier (S/N:1982901A91)
- E. Shielded Room (MLT-SR1)

### 6.4 Test Result:

Frequency (MHz)	Power Density (dBm)	Required Limit
2412	-9.19	<8dBm
2437	-9.64	<8dBm
2462	-9.17	<8dBm

Note :

1. Frequency Span= 600 kHz
2. Sweep Time = Frequency Span/3 kHz=200secs
3. Test Graphs See next page.



# MAX LIGHT

MEASUREMENT REPORT

CH1

Apr 21 12:25:43

REF 10.0 dBm  
10dB/

\*ATT 40dB A\_wrt B\_view  
Posi Posi

Sweep

SWP Time  
AUTO /MNL

SWEEP

Marker  
2.4104008 GHz  
-9.19 dBm

Auto All

200 s

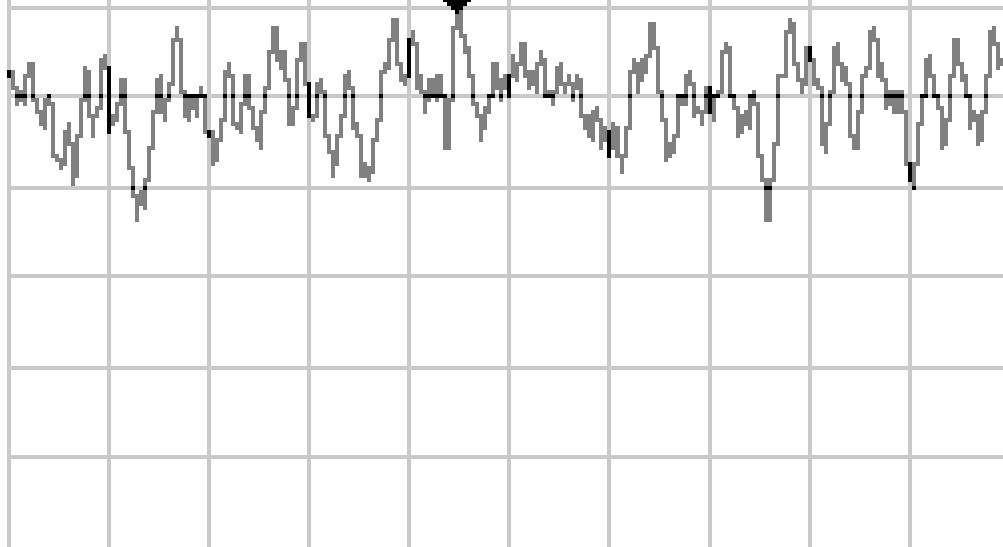

Gate Sig  
External  
ON /OFF

CENTER 2.4104320 GHz SPAN 600 kHz  
\*RBW 3 kHz \*VBW 10 kHz \*SWP 200 s



# MAX LIGHT

## MEASUREMENT REPORT

CH6

Apr 21 11:51:40

REF 10.0 dBm  
10dB/

\*ATT 40dB A\_wrt B\_view  
Posi Posi

Sweep

SWP Time

**SWEEP**

Marker  
2.4372448 GHz  
-9.64 dBm

AUTO /MNL

200 s

Auto All

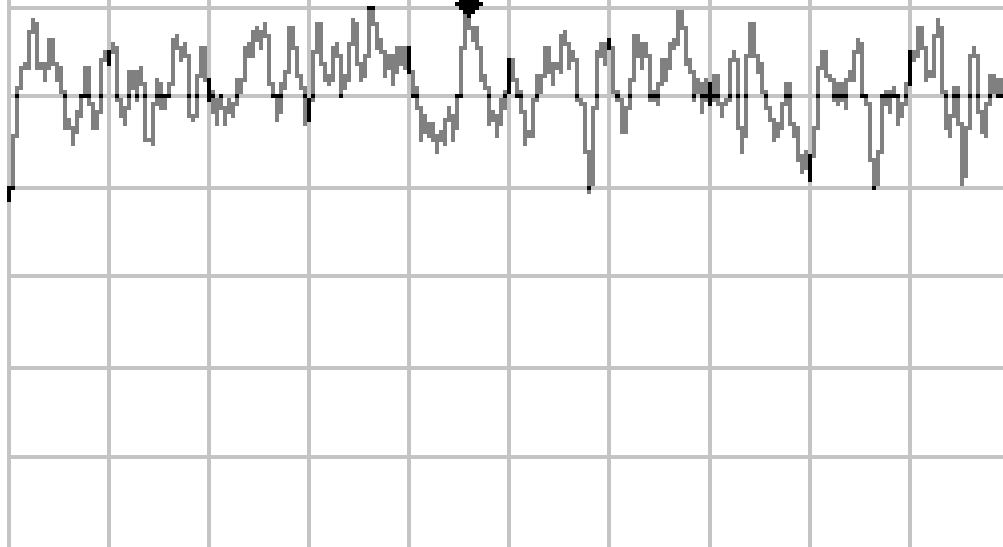

Gate Sig  
External  
ON /OFF

CENTER 2.4372700 GHz SPAN 600 kHz  
\*RBW 3 kHz \*VBW 10 kHz \*SWP 200 s



# MAX LIGHT

MEASUREMENT REPORT

CH11 Apr 21 12:38:35  
REF 10.0 dBm \*ATT 40dB A\_wrt B\_view  
10dB/ Posi Posi

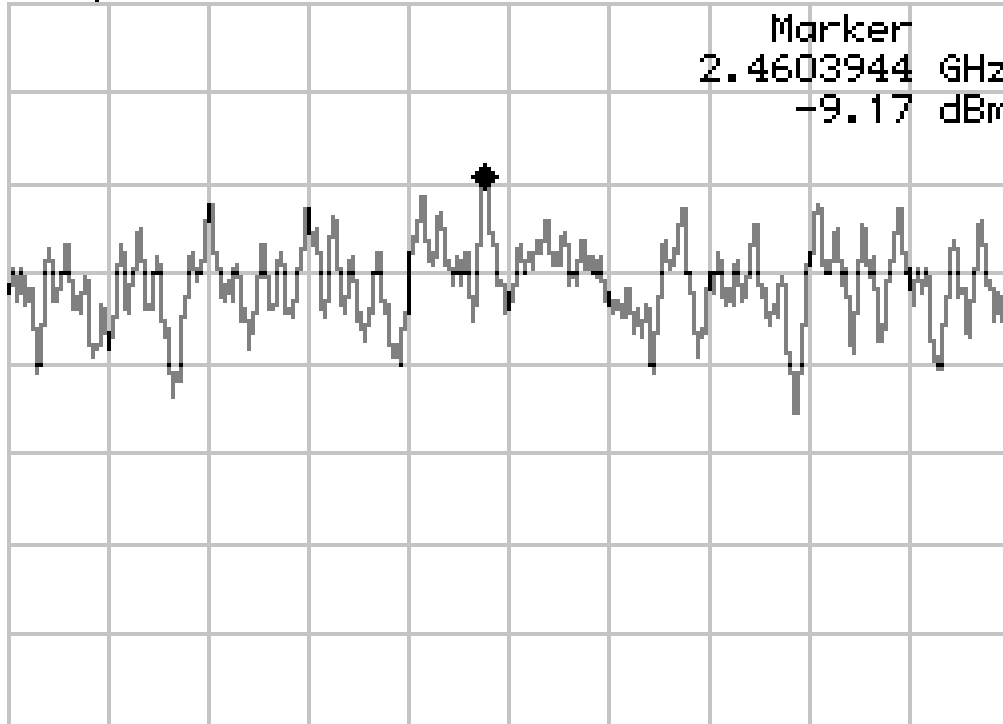

- Display
- Display Line ON /OFF
- Ref Line ON /OFF
- Meas Window ▶
- Change Title ▶
- Time/Date ON /OFF
- Tone GRAY/ B/W
- Inverse

CENTER 2.4604100 GHz SPAN 600 kHz  
\*RBW 3 kHz \*VBW 10 kHz \*SWP 200 s

## VII. Out of Band Conducted Emissions Requirements

### 7.1 Test Condition & Setup :

In any 100 kHz bandwidth outside the EUT passband, the RF power produced by the modulation products of the spreading sequence, the information sequence, and the carrier frequency shall be at least 20 dB below that of the maximum in-band 100 kHz emission, antenna output of the EUT was coupled directly to spectrum analyzer; if an external attenuator and/or cable was used, these losses are compensated for with the analyzer OFFSET function.

All other types of emissions from the EUT shall meet the general limits for radiated frequencies outside the passband. the test was performed at 3 channels (Channel 1, 6,11)

### 7.2 Test Instruments Configuration:

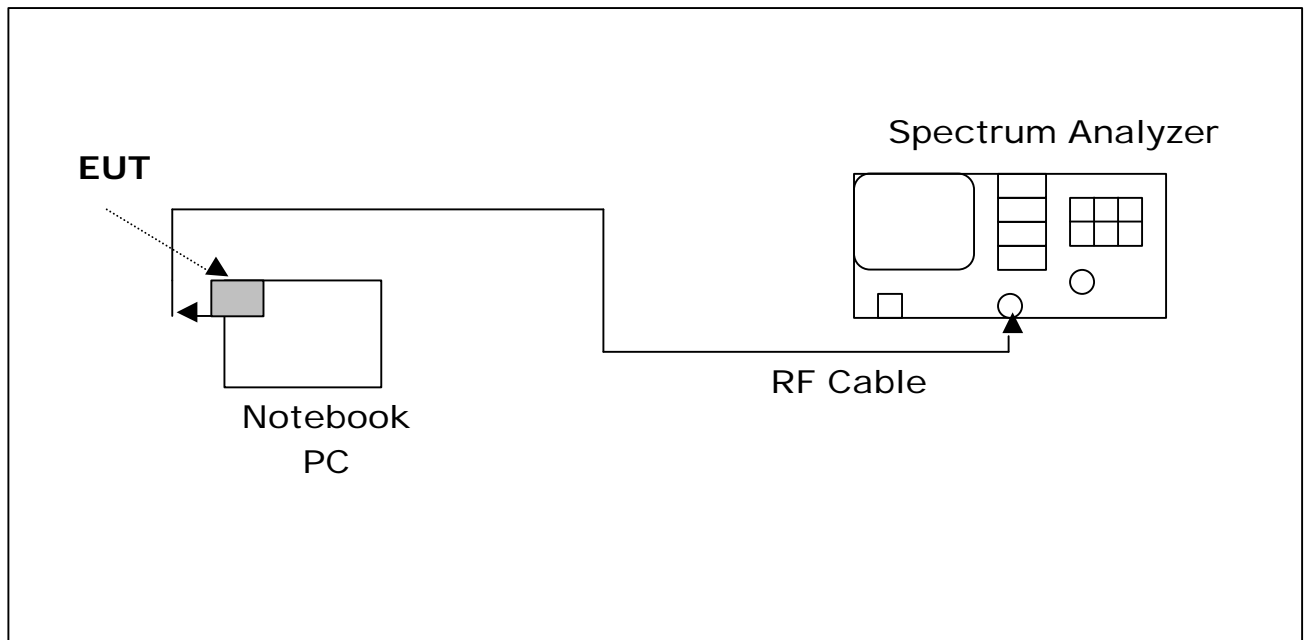



### 7.3 Test Equipment List:

- A. Agilent E4407B 9KHz-26.5GHz Spectrum Analyzer (S/N:A872JS02291)
- B. Shielded Room (MLT-SR1)

### 7.4 Test Result:

Refer to attached data sheets. Data shows out of band emissions are suppressed well below the -20 dBc minimum required by the Rules.

*Note : Test Graphs See next page.*



Channel 01 (1 of 5)

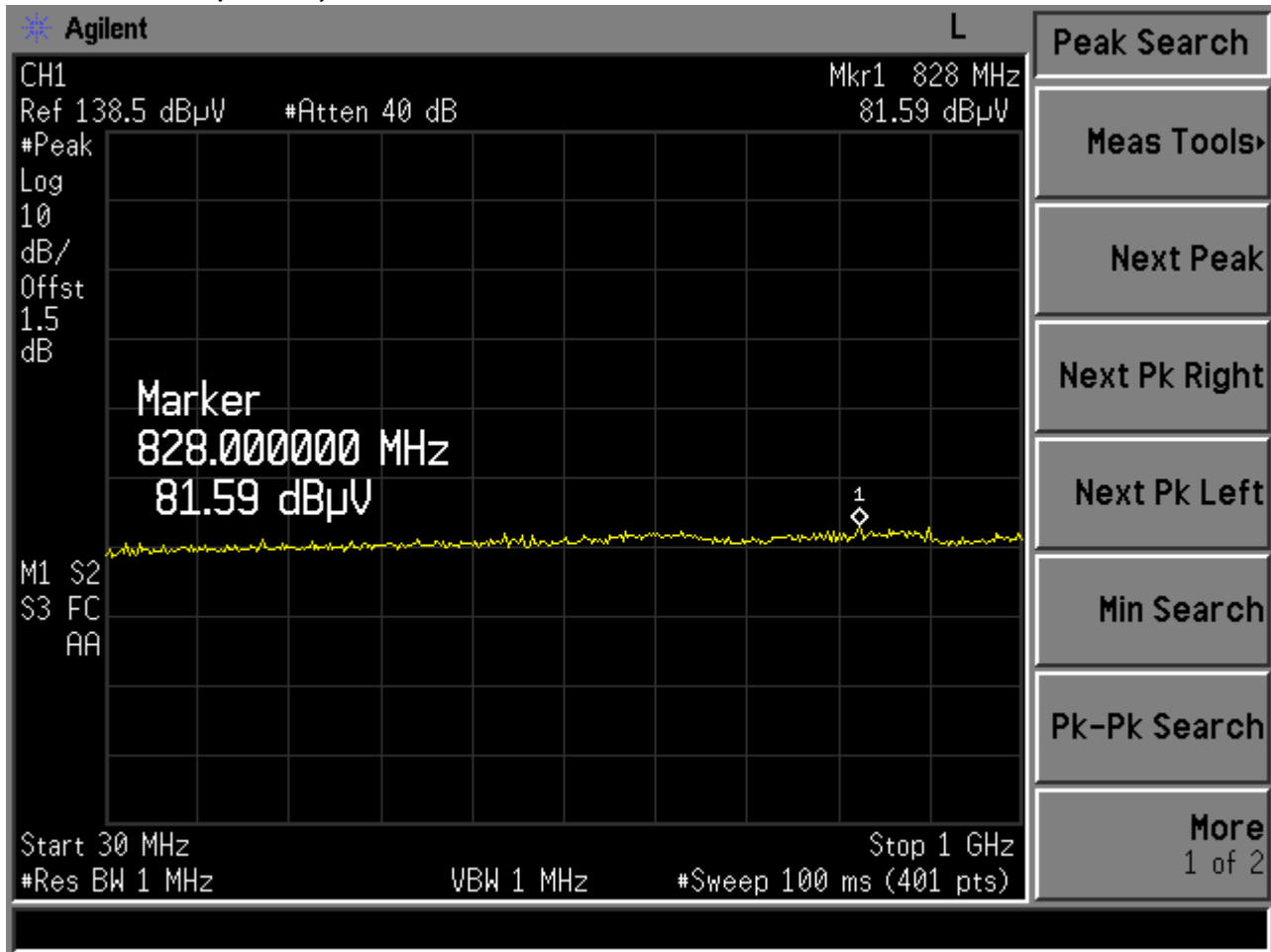

Channel 01 (2 of 5)

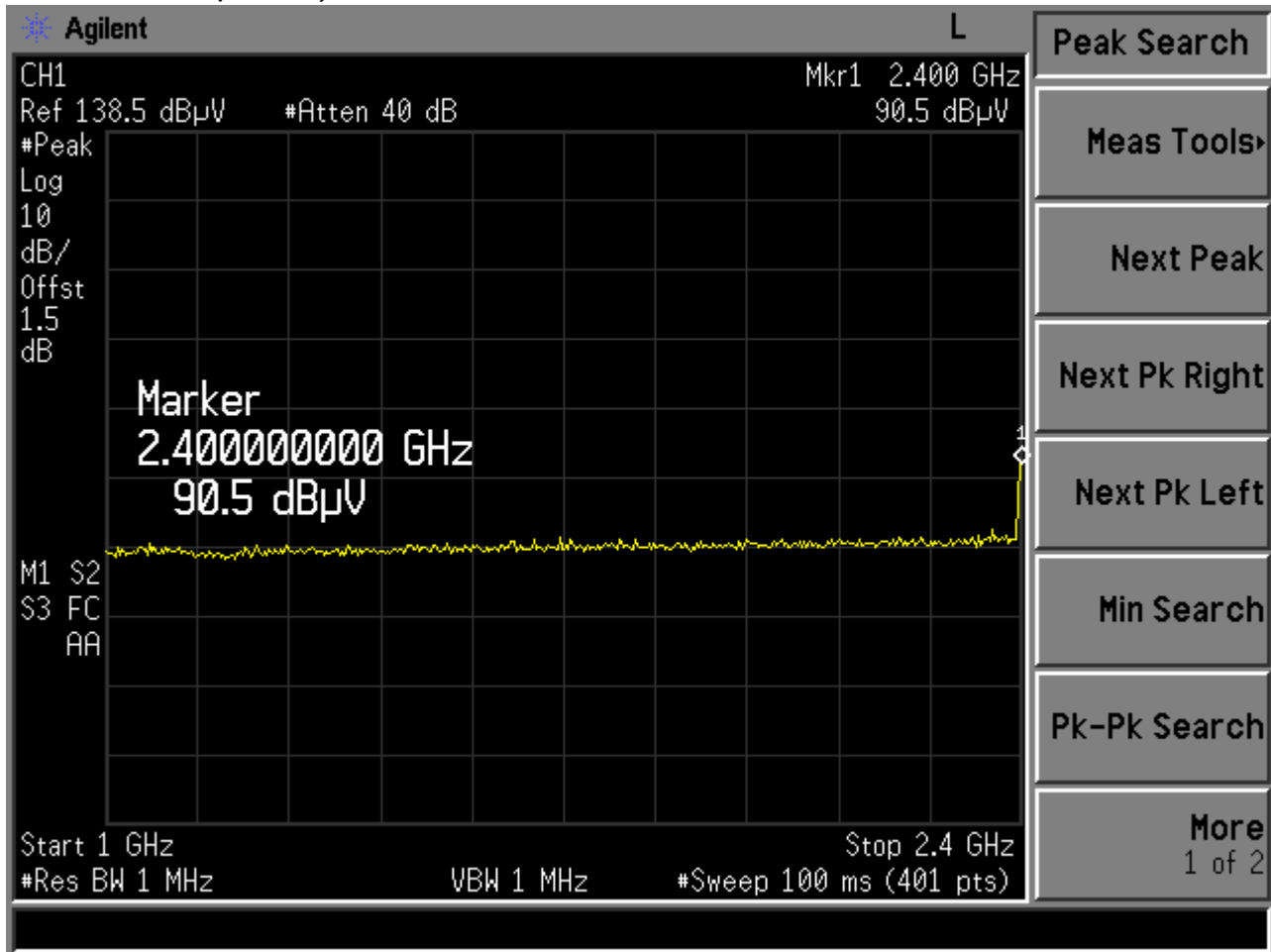

Channel 01 (3 of 5)

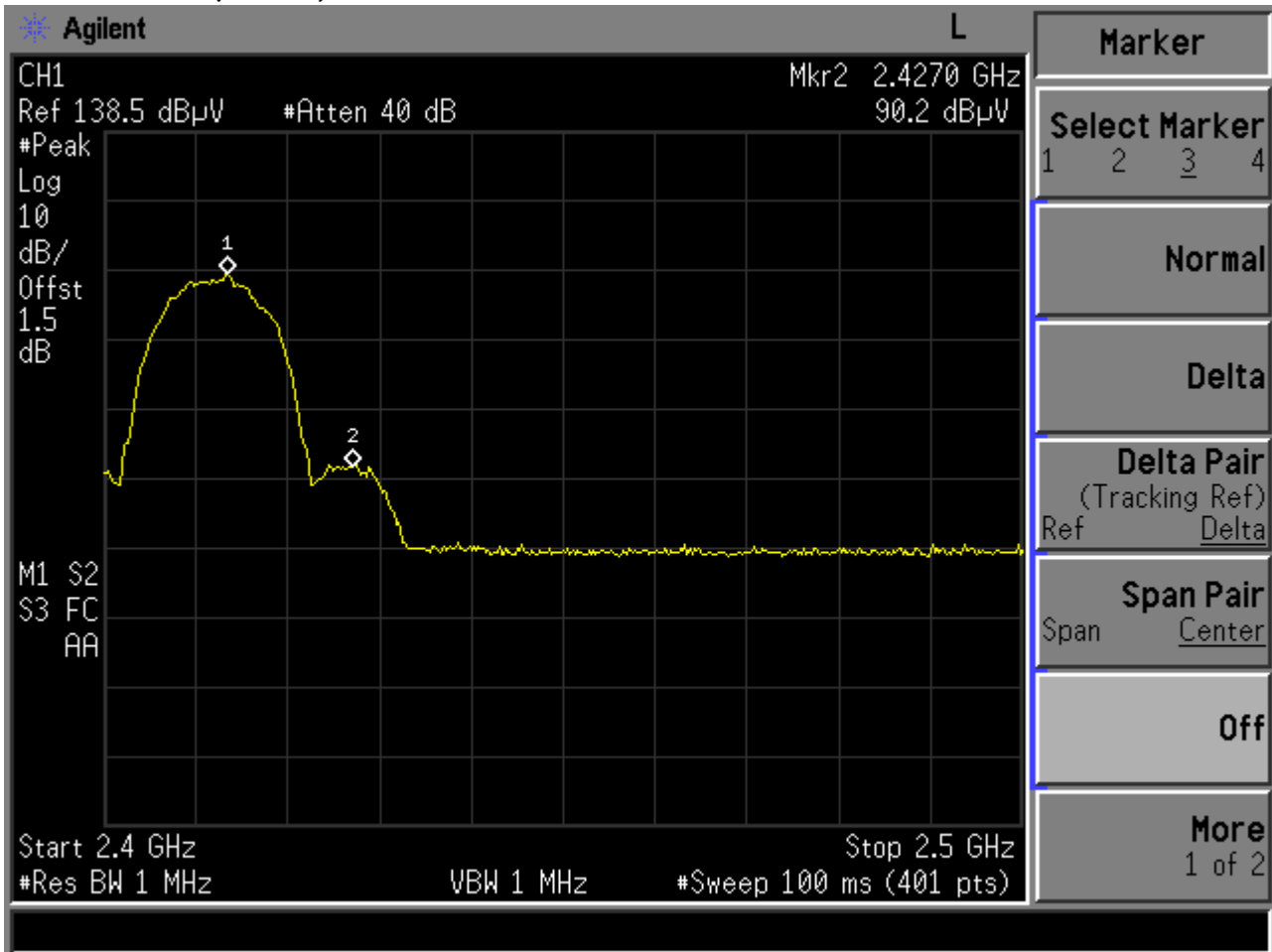

Channel 01 (4 of 5)

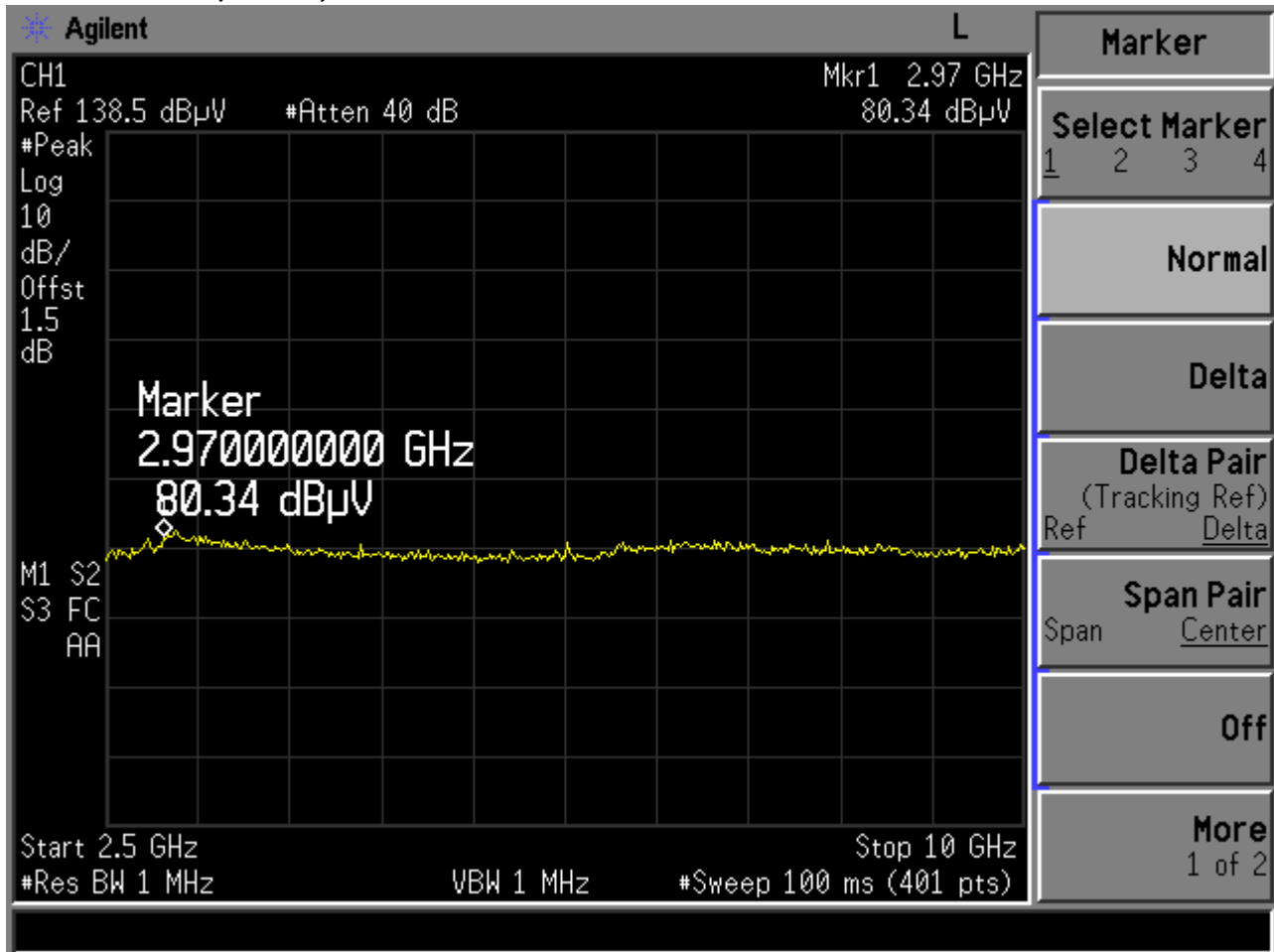

Channel 01 (5 of 5)

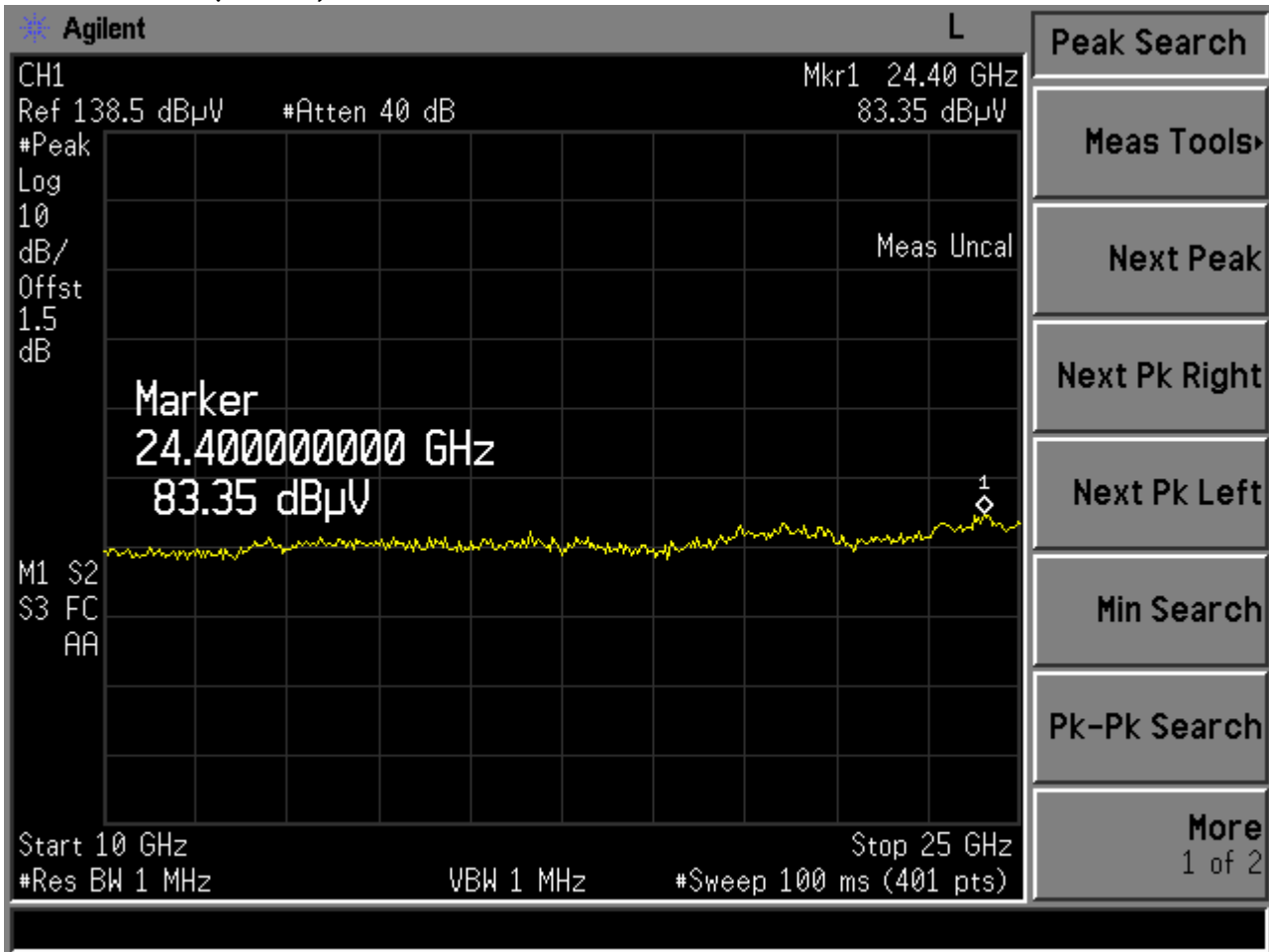

Channel 06 (1 of 5)

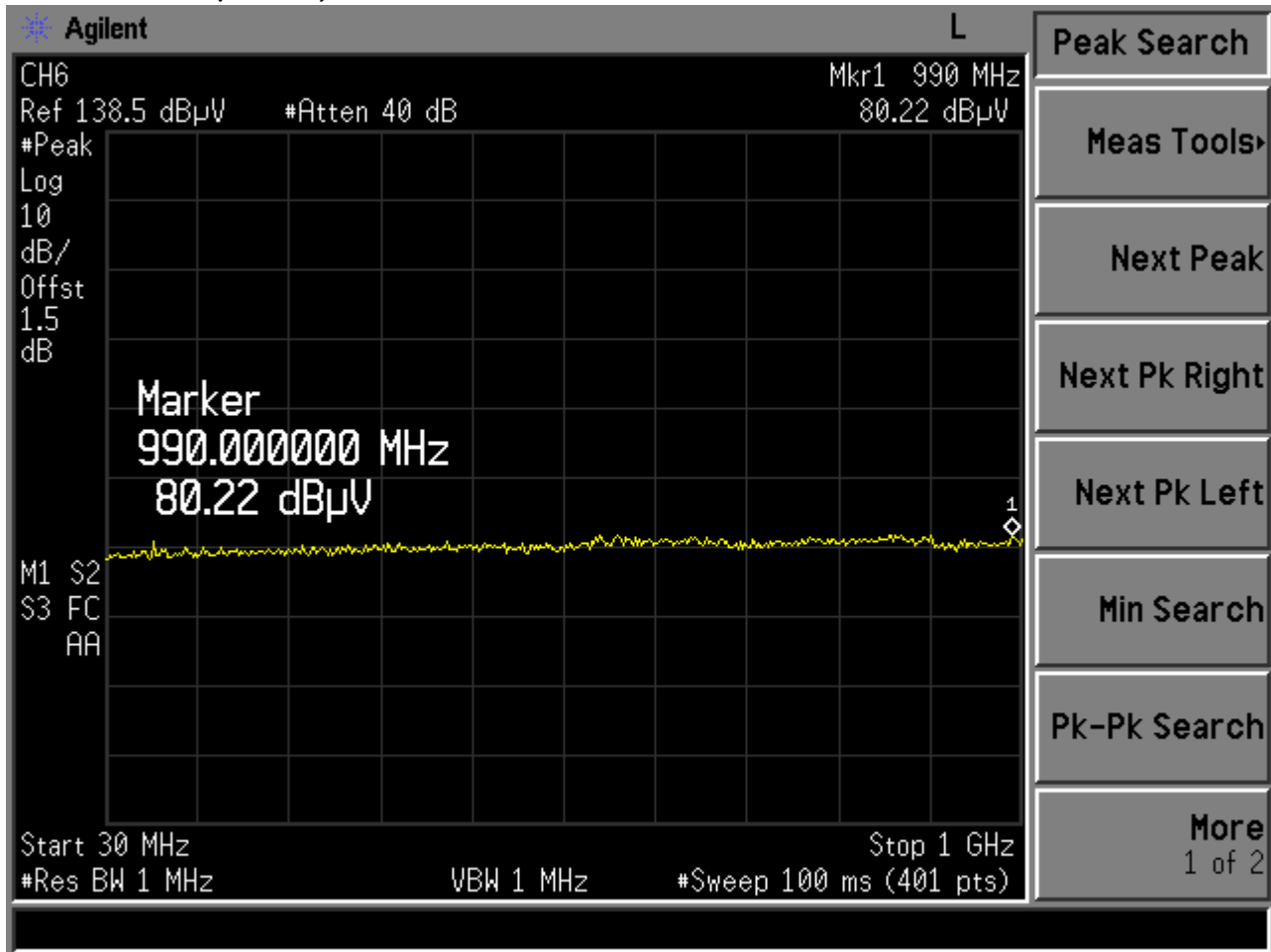

Channel 06 (2 of 5)

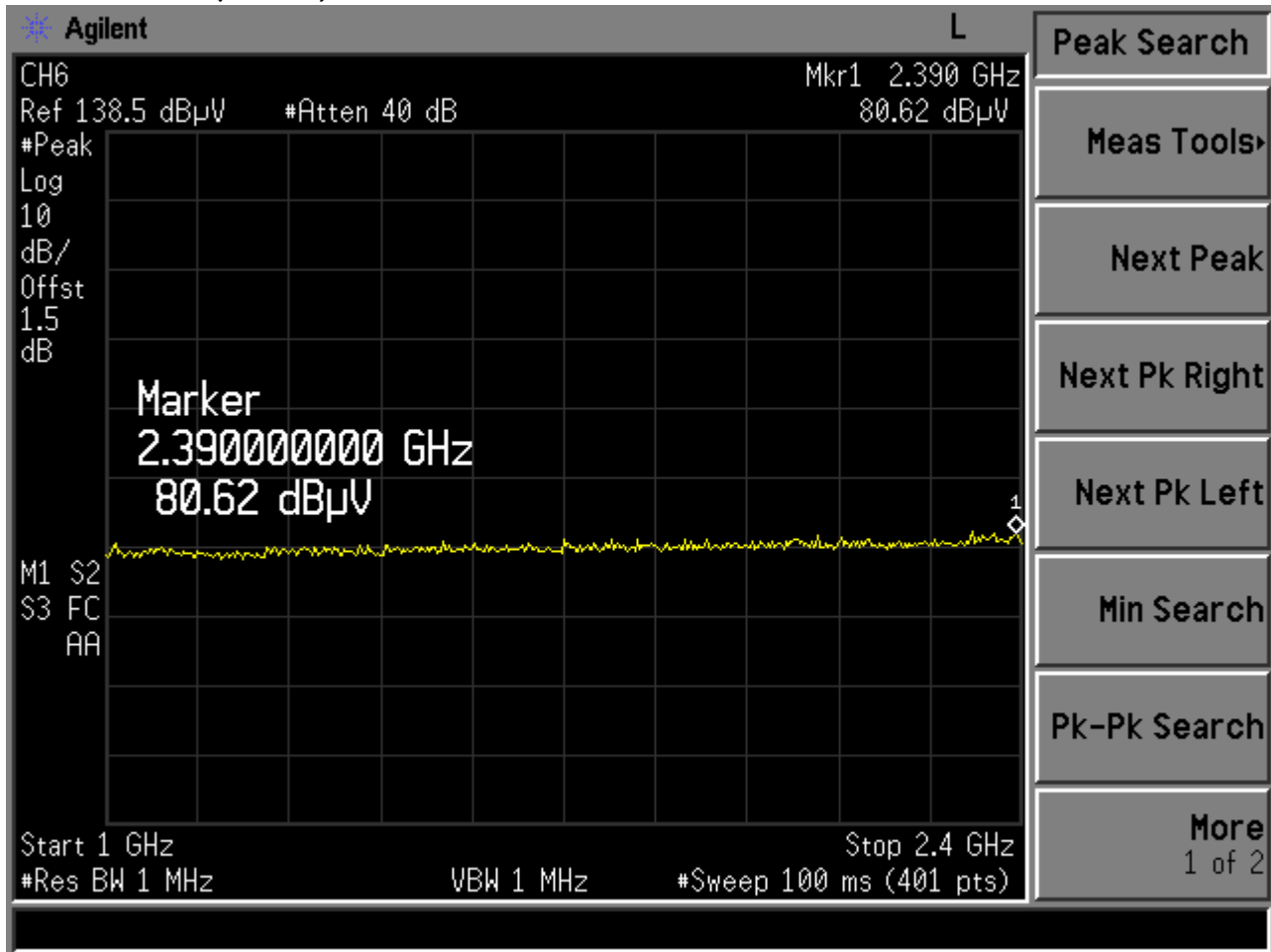

Channel 06 (3 of 5)

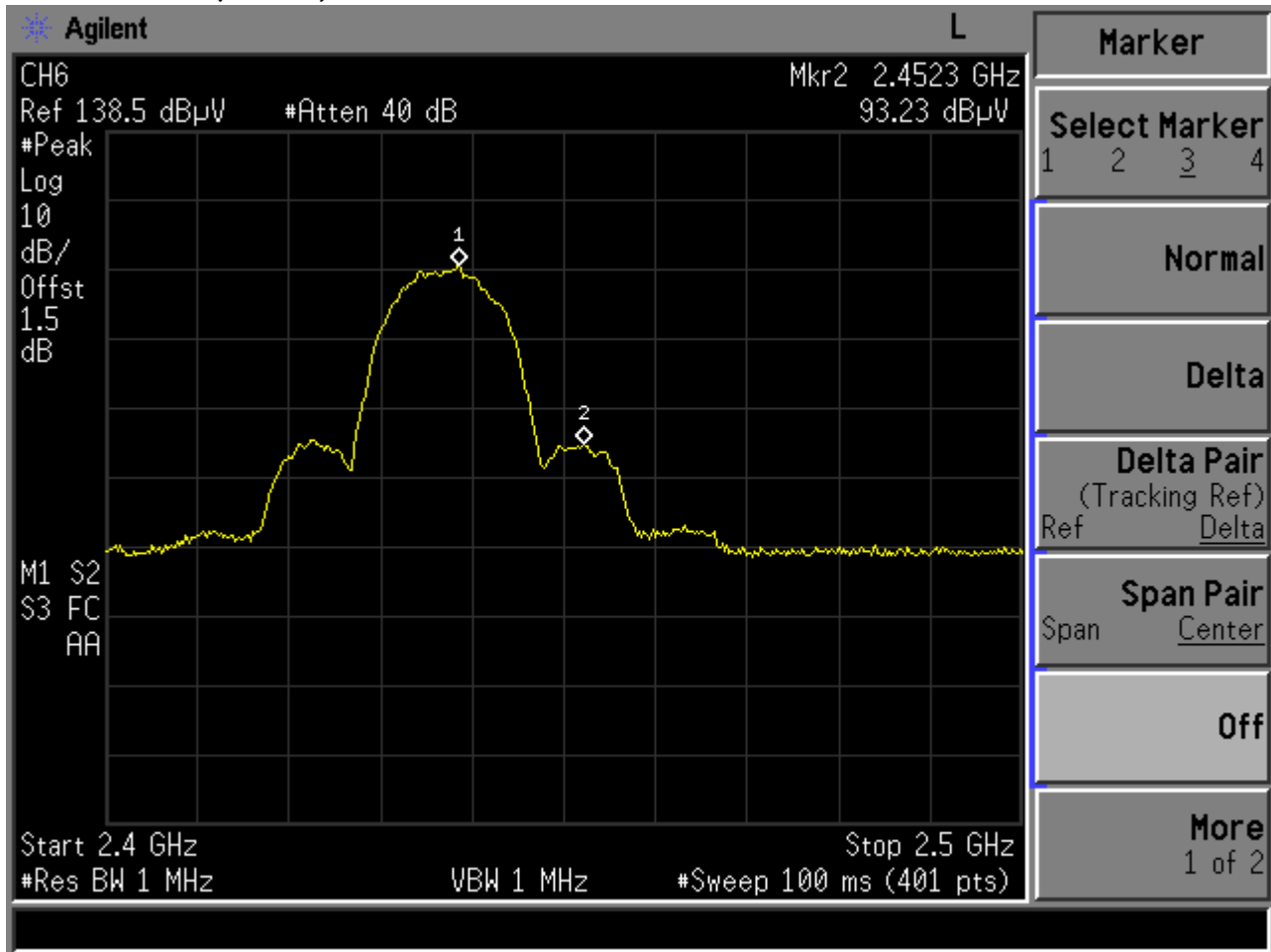



Channel 06 (4 of 5)

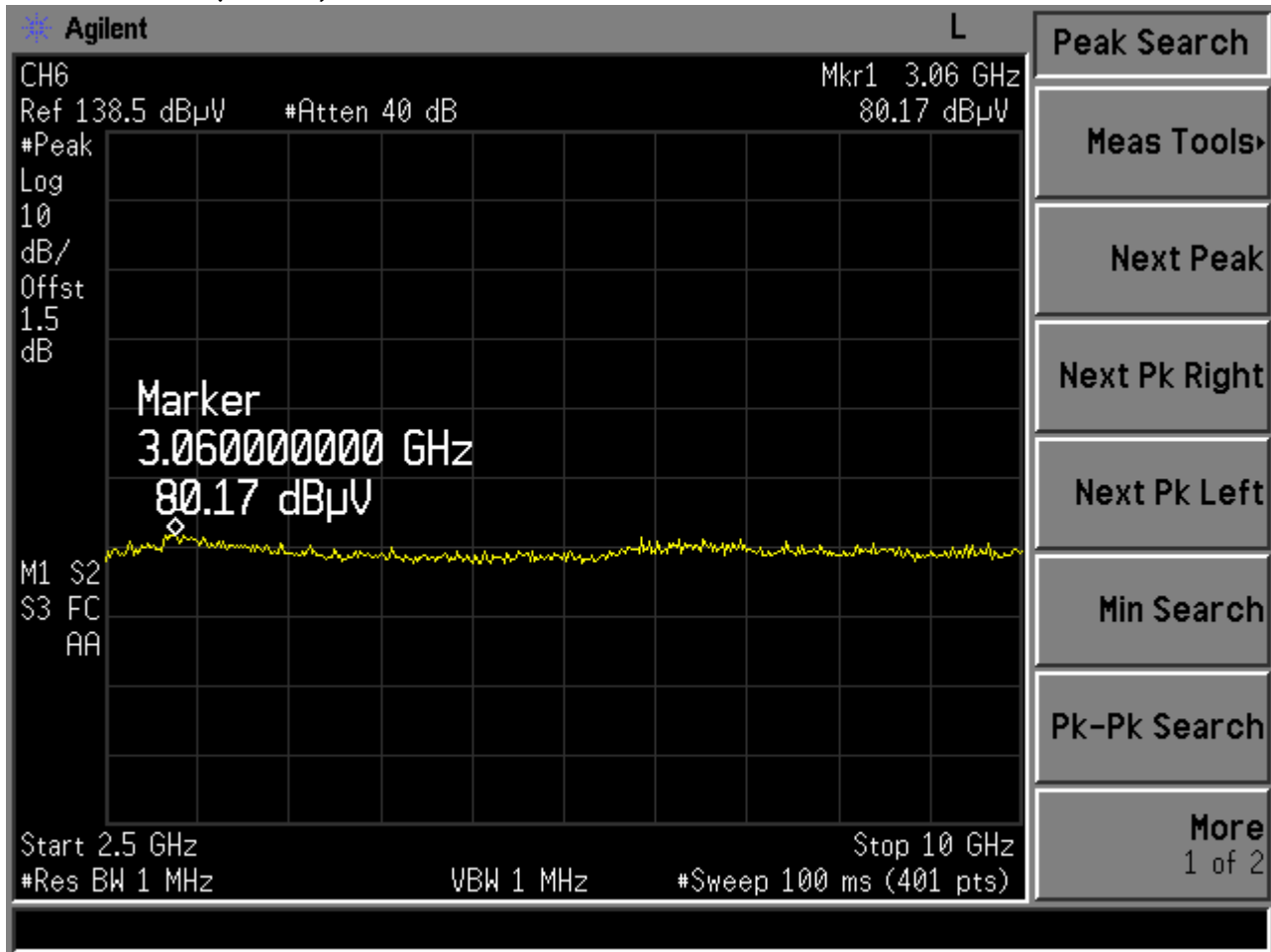

Channel 06 (5 of 5)

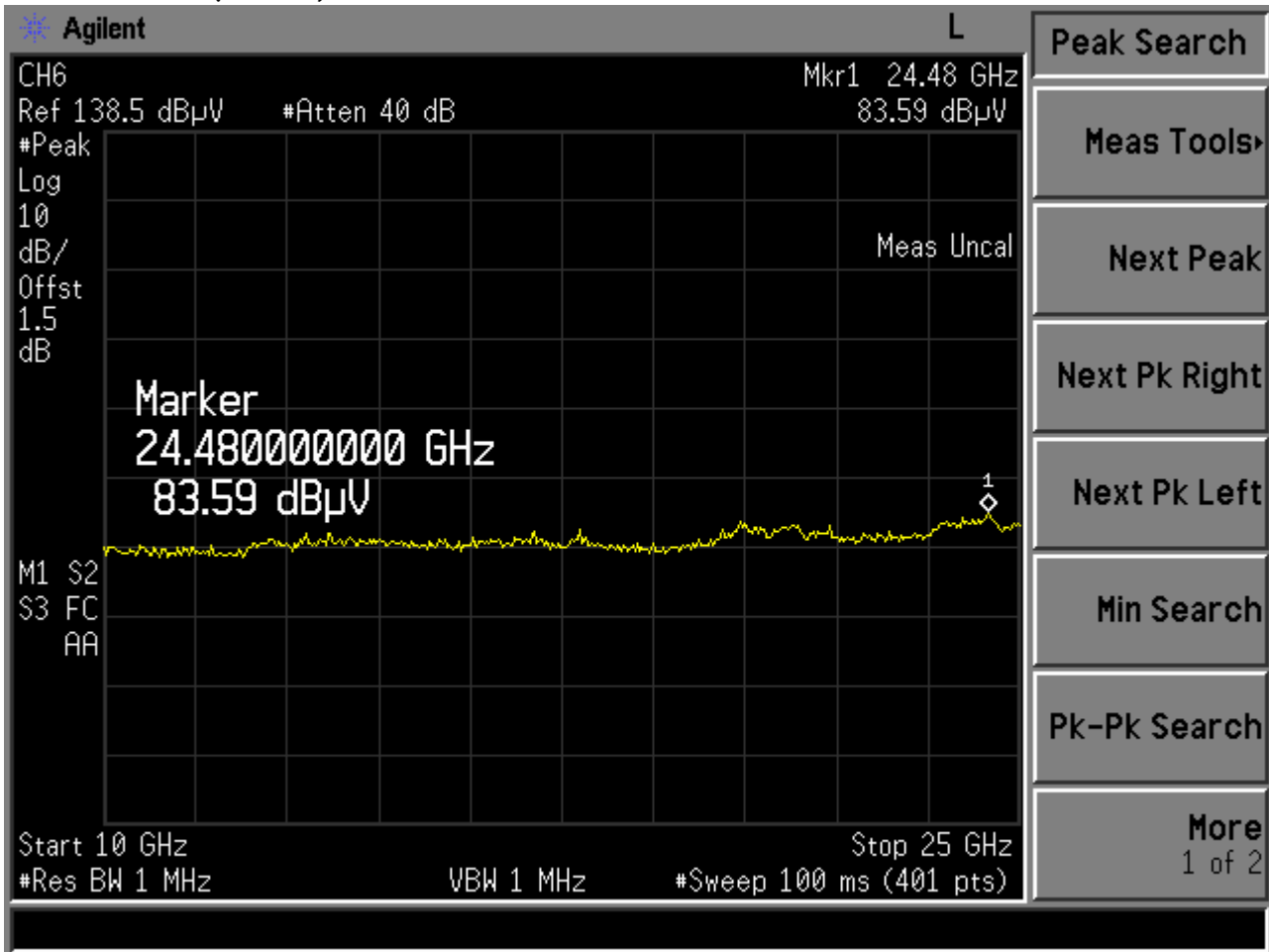

Channel 11 (1 of 5)

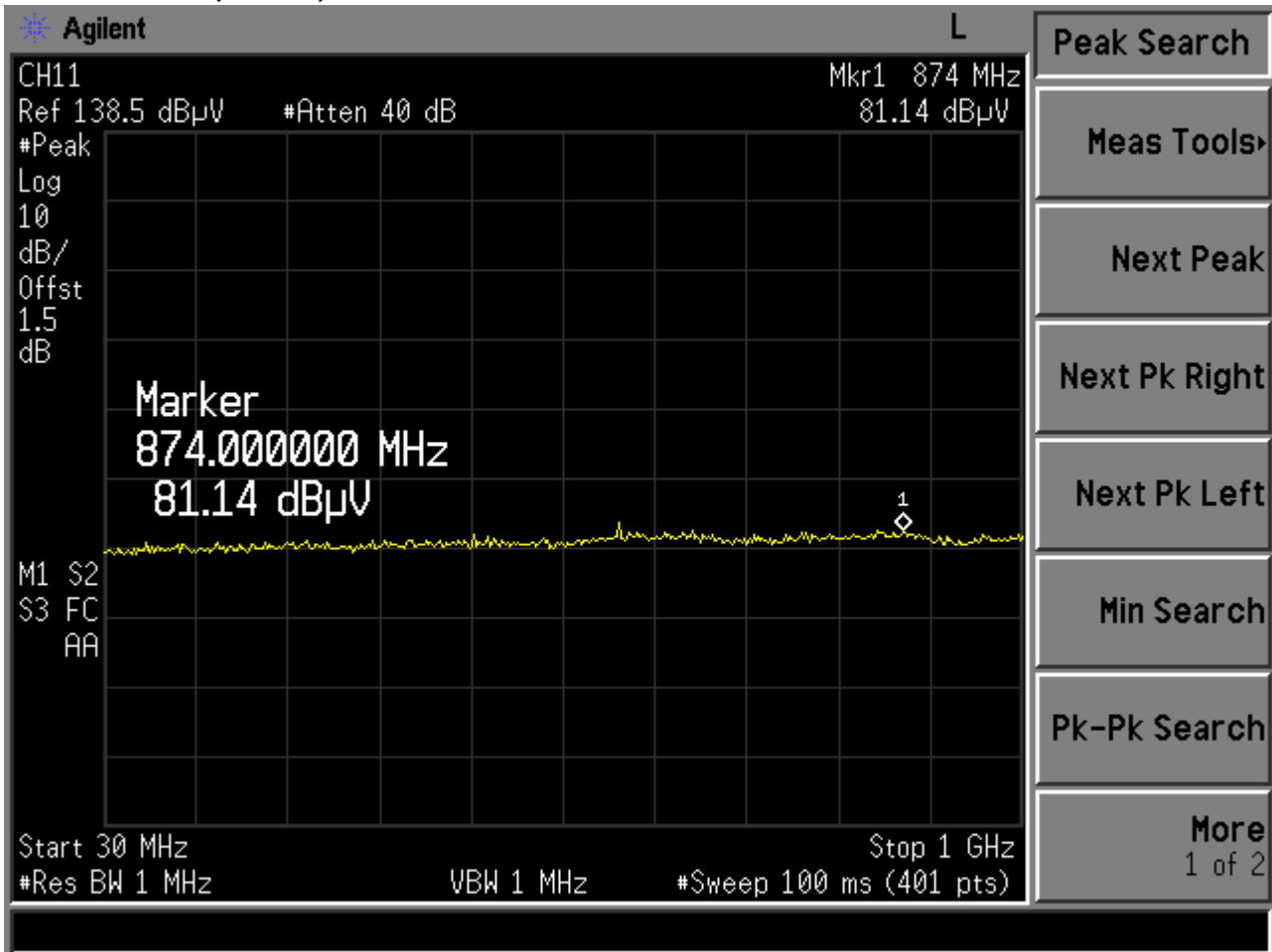

Channel 11 (2 of 5)

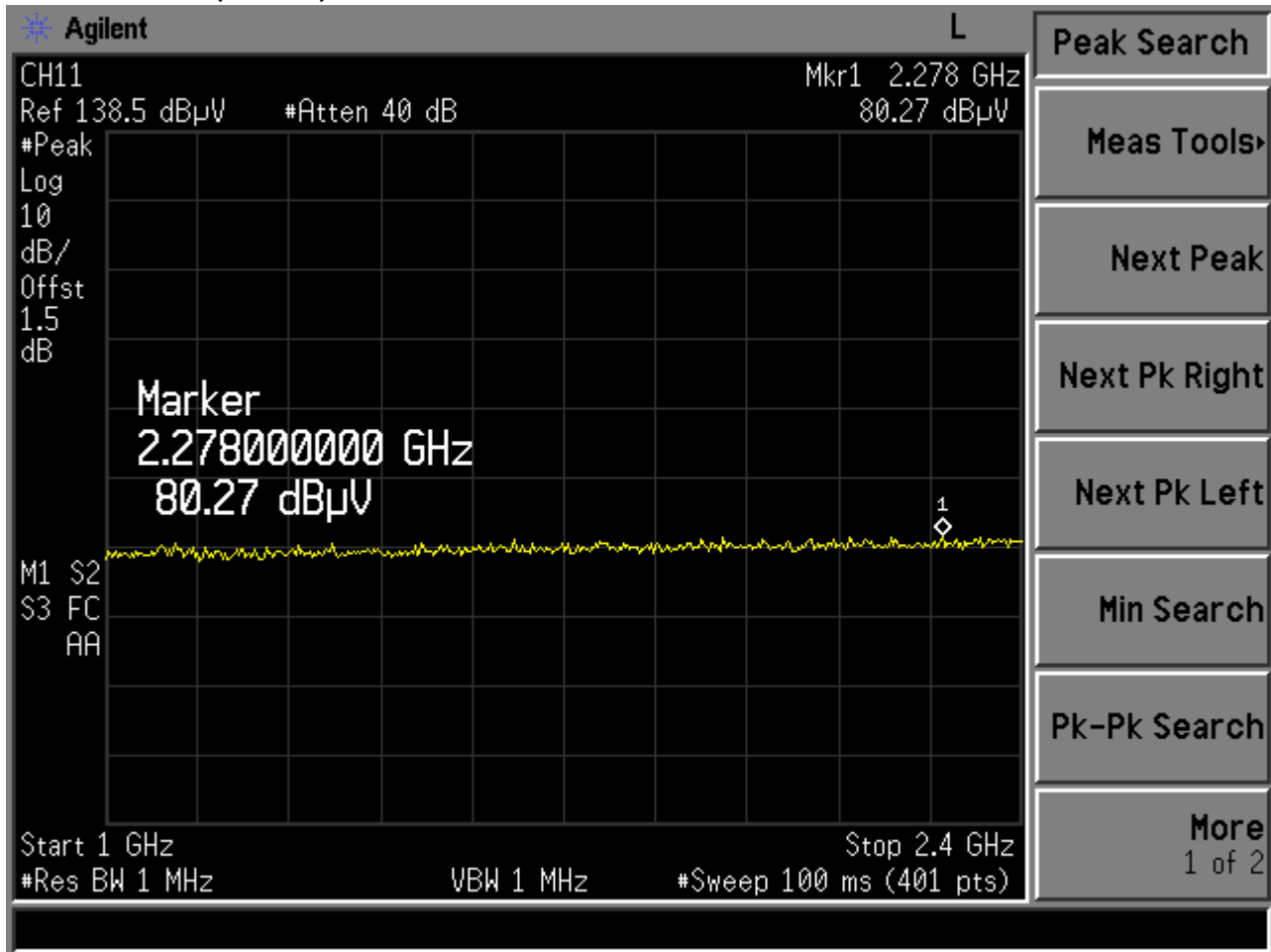

Channel 11 (3 of 5)

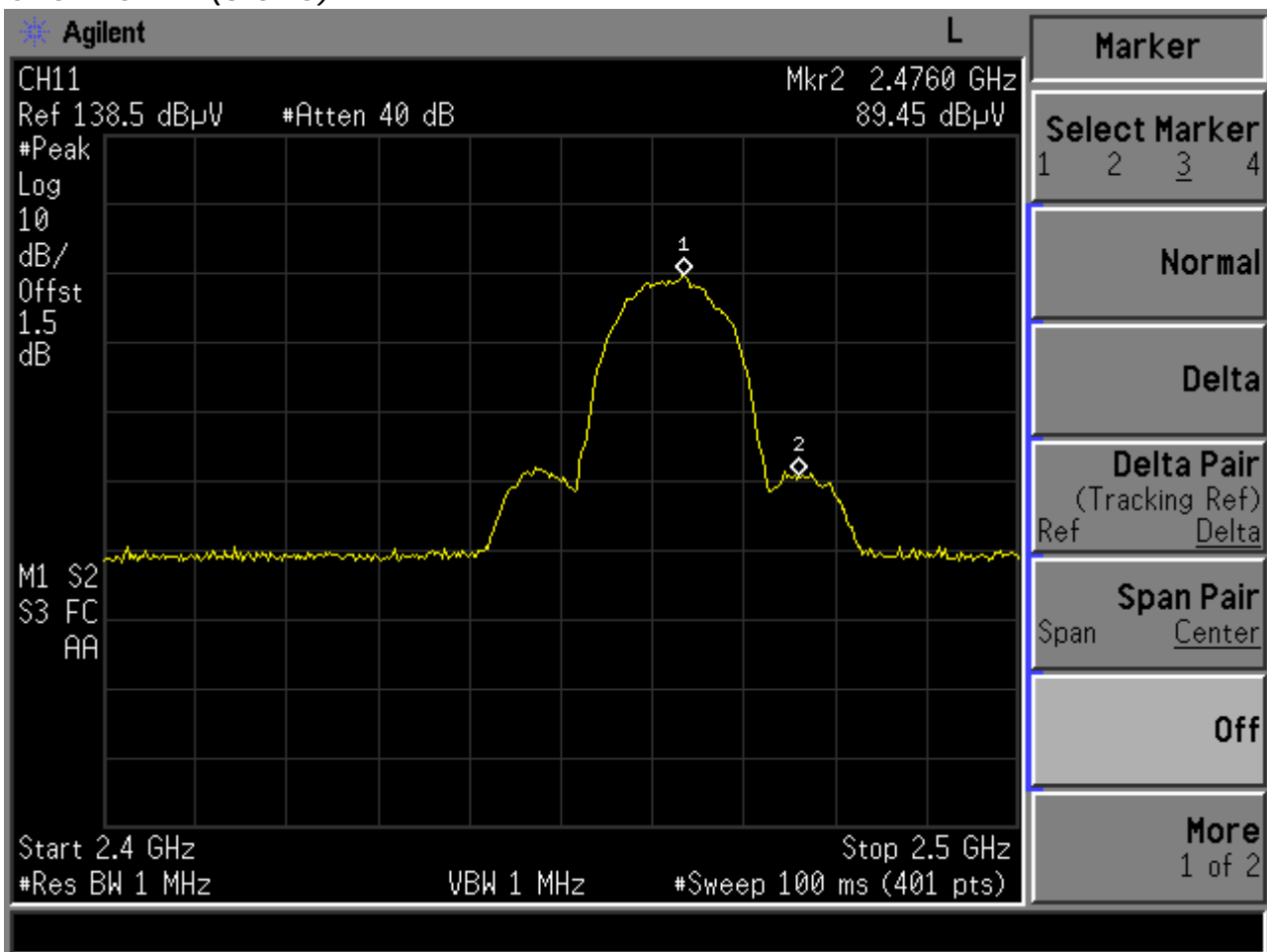

Channel 11 (4 of 5)

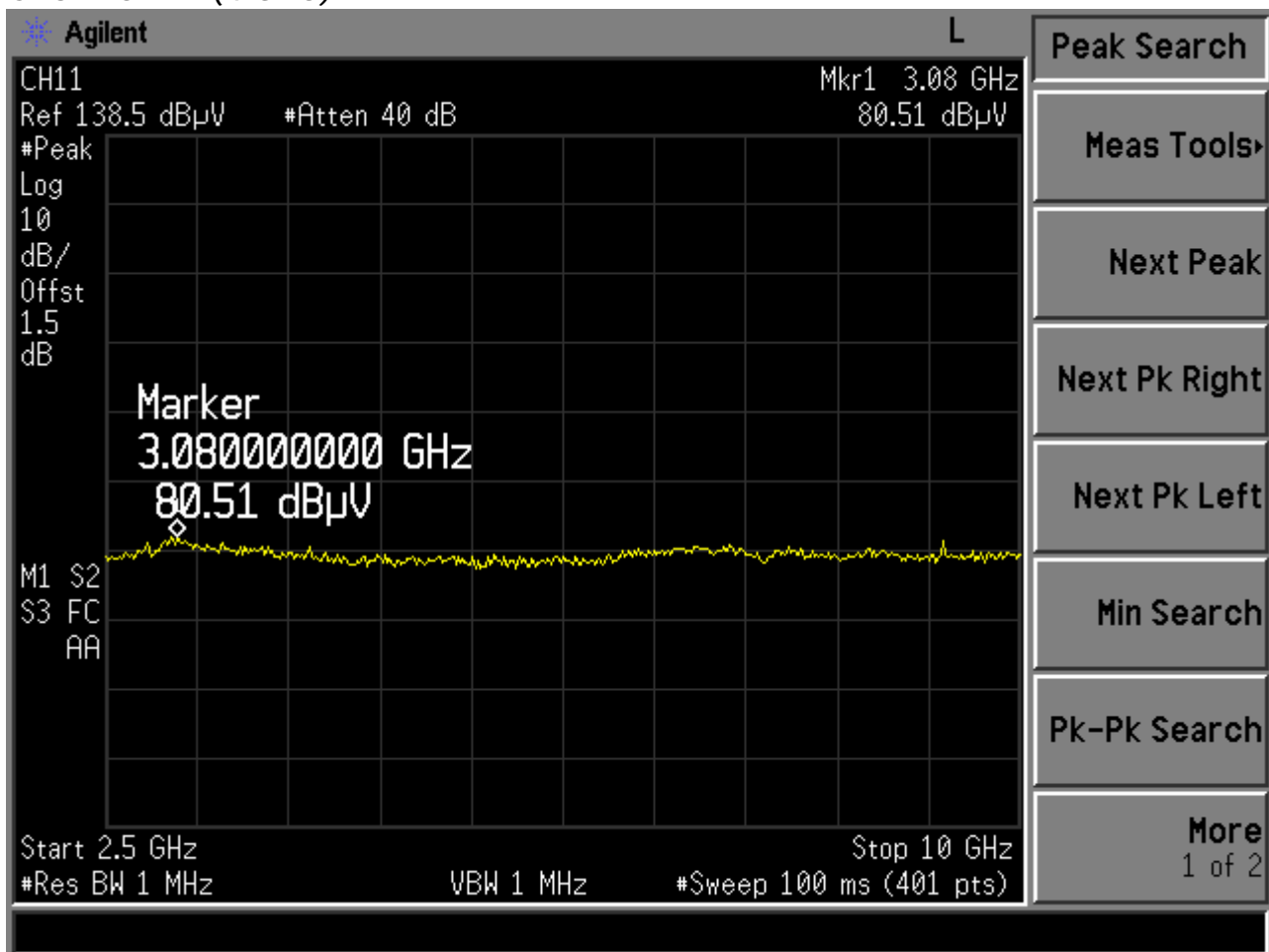

Channel 11 (5 of 5)

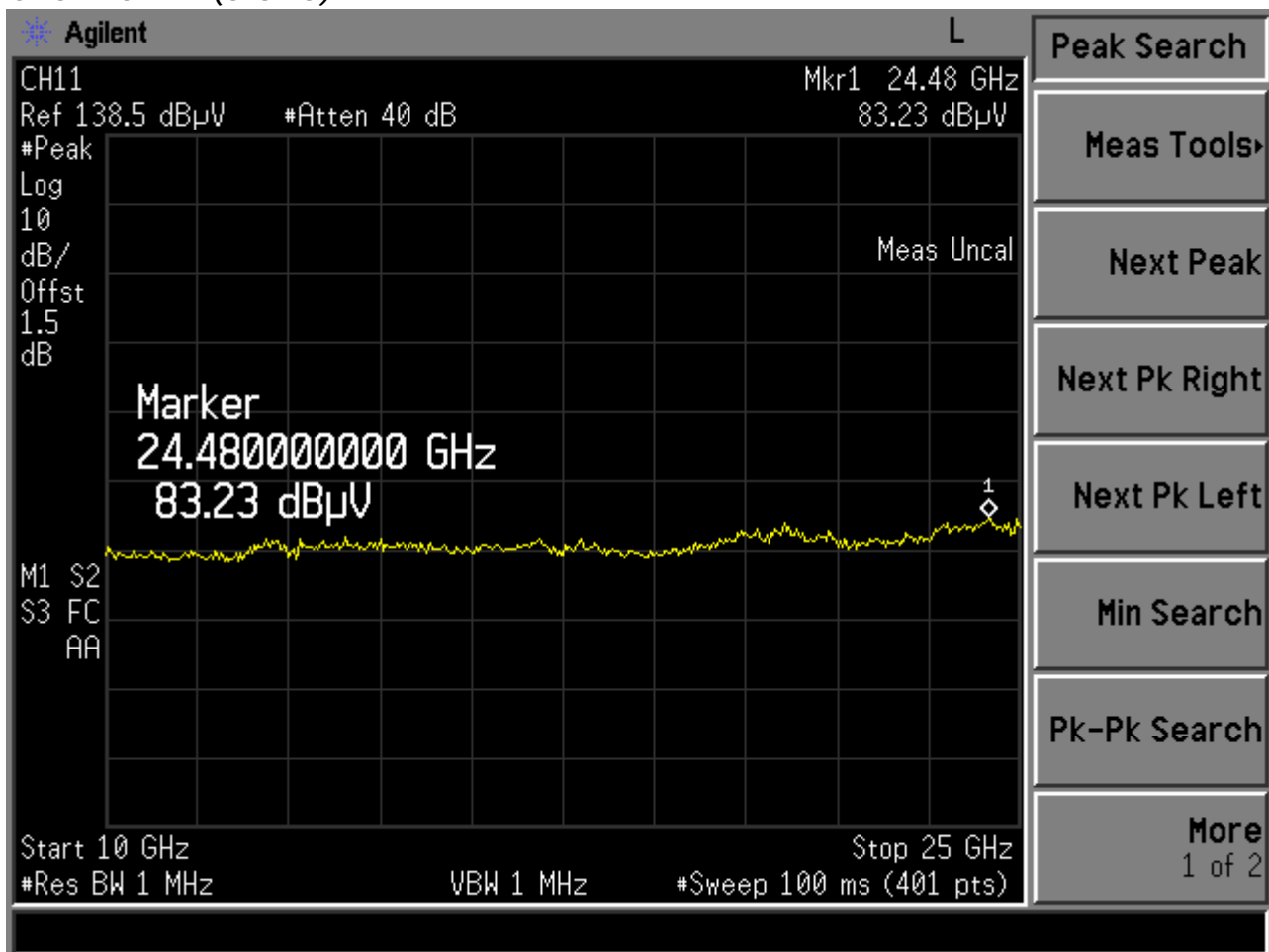

## VIII. Band Edges Requirements

### 8.1 Test Condition & Setup :

The emissions on the harmonics frequencies, the limits, and the margin of compliance are presented. These tests were made when the transmitter was in full radiated power. The additional test was performed to show compliance with the requirement at the band-edge frequency 2483.5 MHz and up to 2500 MHz and at 2390.0 MHz.

The transmitter was configured with the worst case antenna and setup to transmit at the highest channel. Then the field strength was measured at 2483.5 MHz.

The transmitter was then configured with the worst case antenna and setup to transmit at the lowest channel. Then the field strength was measured at 2390.0 MHz. These tests were performed at 4 different bit rates.

### 8.2 Test Instruments Configuration:

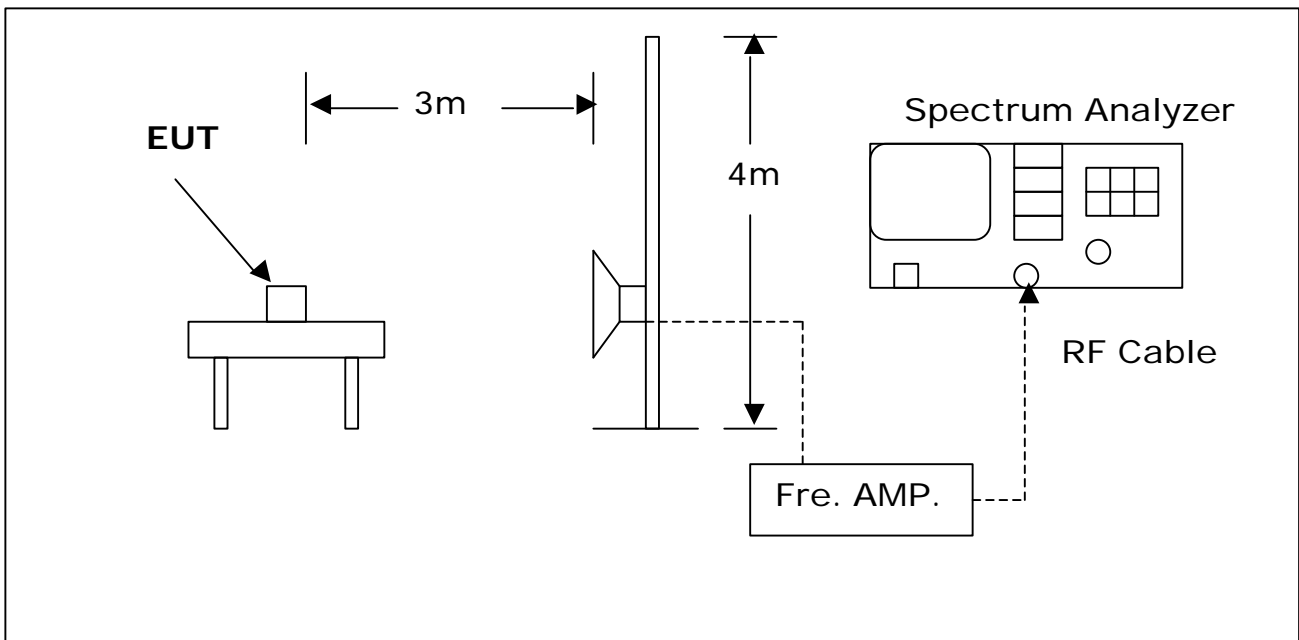



### 8.3 Test Equipment List:

- A. Agilent E4407B 9KHz-26.5GHz Spectrum Analyzer (S/N:A872JS02291)
- B. HP 8449B Pre Amplifier (S/N:1982901A91)
- C. SCHWARZBECK BBHA 9120D Biconilog Antenna (S/N:141S3)

### 8.4 Test Result:

Radiated Emissions (HORIZONTAL) CH1								
Frequency (MHz)	Amplitude (dBuV/m)	Ant. (m)	Table (Degree)	Duty (dB)	Dist (dB)	Actual Amp (dBuV/m)	Limit (dBuV/m)	Margin (dB)
2389.51	59.87	1	360	0	9.54	50.33	54.00	-3.67

Radiated Emissions (VERTICAL) CH1								
Frequency (MHz)	Amplitude (dBuV/m)	Ant. (m)	Table (Degree)	Duty (dB)	Dist (dB)	Actual Amp (dBuV/m)	Limit (dBuV/m)	Margin (dB)
2389.51	57.99	1	360	0	9.54	48.45	54.00	-5.55

Radiated Emissions (HORIZONTAL) CH11								
Frequency (MHz)	Amplitude (dBuV/m)	Ant. (m)	Table (Degree)	Duty (dB)	Dist (dB)	Actual Amp (dBuV/m)	Limit (dBuV/m)	Margin (dB)
2483.50	61.24	1	200	0	9.54	51.70	54.00	-2.30

Radiated Emissions (VERTICAL) CH11								
Frequency (MHz)	Amplitude (dBuV/m)	Ant. (m)	Table (Degree)	Duty (dB)	Dist (dB)	Actual Amp (dBuV/m)	Limit (dBuV/m)	Margin (dB)
2483.50	58.98	1	280	0	9.54	49.44	54.00	-4.56

- Notes :
- 1.Margin= Amplitude - Limits
  - 2.Height of table for EUT placed: 0.8 Meter.
  - 3.ANT= Antenna height.
  - 4.Duty= Duty cycle correction factor.
  - 5.Dis= Distance extrapolation factor.
  - 6.Amplitude= Reading Amplitude - Amplifier gain+Cable loss +Antenna factor  
(Auto calculate in spectrum analyzer)
  - 8.Actual Amp= Amplitude - Duty - Dis.



## IX. Processing Gain Requirements

### 9.1 Test Condition & Setup :

The processing gain shall be determined from the ratio in dB of the signal to noise ratio with the system spreading code turned OFF, to the signal to noise ratio with the system spreading code turned ON, as measured at the demodulated output of the receiver. The processing gain shall be at least 10 dB for a direct sequence spread spectrum system.

*Note : Not Requirement.*



## X. Antenna Requirements

### 10.1 Standard Applicable :

For intentional device, according to 15.203, an intentional radiator shall be designed to ensure that no antenna other than that furnished by the responsible party shall be used with the device.

And According to 15.247 (b), if transmitting antennas of directional gain greater than 6 dBi are used, the power shall be reduced by the amount in dB that the directional gain of the antenna exceeds 6dBi.

### 10.2 Antenna Connector Construction

The antenna used in this product is Printed antenna. No antenna connector is provided in this product. And the maximum Gain of this antenna is only 1.72dBi .

Appendix I- EUT Test SETUP

**MEASUREMENT OF POWER LINE CONDUCTED RFI VOLTAGE**

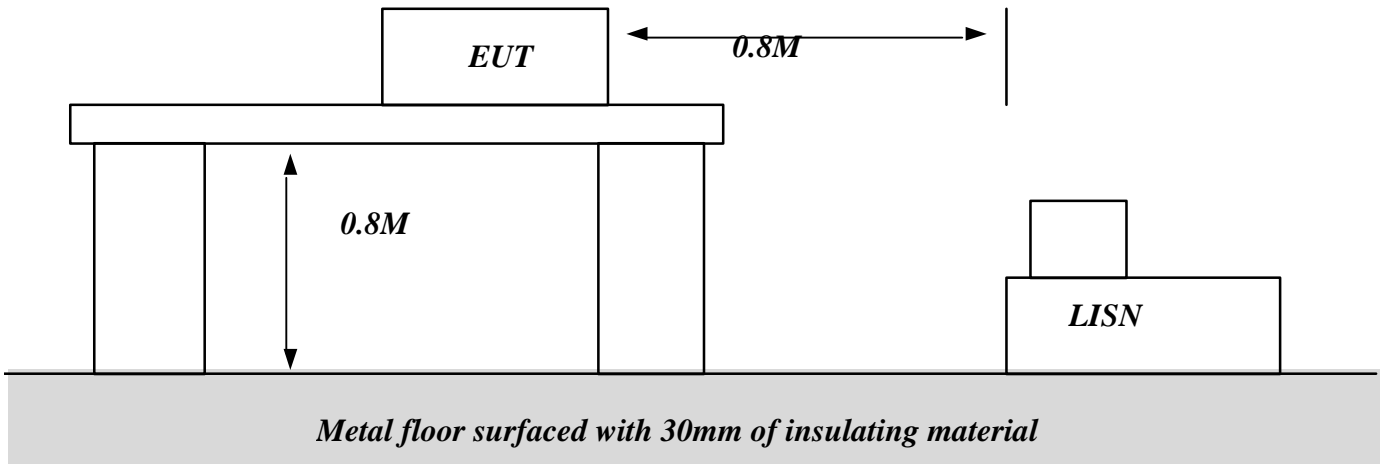

Appendix I- EUT Test SETUP

**MEASUREMENT OF RADIATED EMISSION**

