



A D T

# FCC TEST REPORT (15.407)

**REPORT NO.:** RF110721C33B-1

**MODEL NO.:** AP-8100

**FCC ID:** HZB-AP8100

**RECEIVED:** Jul. 21, 2011

**TESTED:** Oct. 27 ~ Nov. 29, 2011

**ISSUED:** Mar. 27, 2012

**APPLICANT:** Proxim Wireless Corporation

**ADDRESS:** 1561 Buckeye Drive, Milpitas, California, United States, 95035

**ISSUED BY:** Bureau Veritas Consumer Products Services (H.K.) Ltd., Taoyuan Branch

**LAB ADDRESS:** No. 47, 14th Ling, Chia Pau Vil., Lin Kou Dist., New Taipei City, Taiwan ( R.O.C )

**TEST LOCATION:** No. 19, Hwa Ya 2nd Rd., Wen Hwa Tsuen, Kwei Shan Hsiang, Taoyuan Hsien 333, Taiwan, R.O.C.

This test report consists of 56 pages in total. It may be duplicated completely for legal use with the approval of the applicant. It should not be reproduced except in full, without the written approval of our laboratory. The client should not use it to claim product, certification, approval or endorsement by TAF or any government agency. The test results in the report only apply to the tested sample.



## TABLE OF CONTENTS

RELEASE CONTROL RECORD .....	4
1. CERTIFICATION .....	5
2. SUMMARY OF TEST RESULTS .....	6
2.1 MEASUREMENT UNCERTAINTY .....	6
3. GENERAL INFORMATION .....	7
3.1 GENERAL DESCRIPTION OF EUT .....	7
3.2 DESCRIPTION OF TEST MODES .....	8
3.2.1 CONFIGURATION OF SYSTEM UNDER TEST .....	9
3.2.2 DESCRIPTION OF SUPPORT UNITS .....	10
3.2.3 TEST MODE APPLICABILITY AND TESTED CHANNEL DETAIL .....	11
3.3 GENERAL DESCRIPTION OF APPLIED STANDARDS .....	13
4. TEST TYPES AND RESULTS .....	14
4.1 RADIATED EMISSION MEASUREMENT .....	14
4.1.1 LIMITS OF RADIATED EMISSION MEASUREMENT .....	14
4.1.2 LIMITS OF UNWANTED EMISSION OUT OF THE RESTRICTED BANDS .....	14
4.1.3 TEST INSTRUMENTS .....	15
4.1.4 TEST PROCEDURES .....	16
4.1.5 DEVIATION FROM TEST STANDARD .....	16
4.1.6 TEST SETUP .....	17
4.1.7 EUT OPERATING CONDITION .....	17
4.1.8 TEST RESULTS .....	18
4.2 CONDUCTED EMISSION MEASUREMENT .....	28
4.2.1 LIMITS OF CONDUCTED EMISSION MEASUREMENT .....	28
4.2.2 TEST INSTRUMENTS .....	28
4.2.3 TEST PROCEDURES .....	29
4.2.4 DEVIATION FROM TEST STANDARD .....	29
4.2.5 TEST SETUP .....	30
4.2.6 EUT OPERATING CONDITIONS .....	30
4.2.7 TEST RESULTS .....	31
4.3 MAXIMUM CONDUCTED OUTPUT POWER MEASUREMENT .....	35
4.3.1 LIMITS OF MAXIMUM CONDUCTED OUTPUT POWER MEASUREMENT .....	35
4.3.2 TEST SETUP .....	35
4.3.3 TEST INSTRUMENTS .....	35
4.3.4 TEST PROCEDURE .....	35
4.3.5 DEVIATION FROM TEST STANDARD .....	35
4.3.6 EUT OPERATING CONDITIONS .....	35
4.3.7 TEST RESULTS .....	36
4.4 PEAK POWER EXCURSION MEASUREMENT .....	42
4.4.1 LIMITS OF PEAK POWER EXCURSION MEASUREMENT .....	42
4.4.2 TEST SETUP .....	42
4.4.3 TEST INSTRUMENTS .....	42
4.4.4 TEST PROCEDURE .....	42
4.4.5 DEVIATION FROM TEST STANDARD .....	42
4.4.6 EUT OPERATING CONDITIONS .....	42
4.4.7 TEST RESULTS .....	43
4.5 PEAK POWER SPECTRAL DENSITY MEASUREMENT .....	49
4.5.1 LIMITS OF PEAK POWER SPECTRAL DENSITY MEASUREMENT .....	49
4.5.2 TEST SETUP .....	49



A D T

4.5.3	TEST INSTRUMENTS.....	49
4.5.4	TEST PROCEDURES .....	49
4.5.5	DEVIATION FROM TEST STANDARD.....	49
4.5.6	EUT OPERATING CONDITIONS .....	49
4.5.7	TEST RESULTS .....	50
4.6	FREQUENCY STABILITY.....	51
4.6.1	LIMITS OF FREQUENCY STABILITY MEASUREMENT .....	51
4.6.2	TEST SETUP.....	51
4.6.3	TEST INSTRUMENTS.....	51
4.6.4	TEST PROCEDURE.....	52
4.6.5	DEVIATION FROM TEST STANDARD.....	52
4.6.6	EUT OPERATING CONDITION.....	52
4.6.7	TEST RESULTS .....	53
5.	PHOTOGRAPHS OF THE TEST CONFIGURATION.....	54
6.	INFORMATION ON THE TESTING LABORATORIES .....	55
7.	APPENDIX A - MODIFICATIONS RECORDERS FOR ENGINEERING CHANGES TO THE EUT BY THE LAB.....	56



## RELEASE CONTROL RECORD

ISSUE NO.	REASON FOR CHANGE	DATE ISSUED
RF110721C33B-1	Original release	Mar. 27, 2012



## 1. CERTIFICATION

**PRODUCT:** Wireless 802.11 abgn Router

**MODEL:** AP-8100

**BRAND:** Proxim

**APPLICANT:** Proxim Wireless Corporation

**TESTED:** Oct. 27 ~ Nov. 29, 2011

**TEST SAMPLE:** ENGINEERING SAMPLE

**STANDARDS:** **FCC Part 15, Subpart E (Section 15.407)**

ANSI C63.10-2009

The above equipment (Model: AP-8100) has been tested by **Bureau Veritas Consumer Products Services (H.K.) Ltd., Taoyuan Branch**, and found compliance with the requirement of the above standards. The test record, data evaluation & Equipment Under Test (EUT) configurations represented herein are true and accurate accounts of the measurements of the sample's EMC characteristics under the conditions specified in this report.

PREPARED BY : Andrea Hsia , DATE : Mar. 27, 2012  
Andrea Hsia / Specialist

APPROVED BY : Gary Chang , DATE : Mar. 27, 2012  
Gary Chang / Technical Manager

## 2. SUMMARY OF TEST RESULTS

The EUT has been tested according to the following specifications:

APPLIED STANDARD: FCC PART 15, SUBPART E (SECTION 15.407)			
STANDARD SECTION	TEST TYPE	RESULT	REMARK
15.407(b)(6)	AC Power Conducted Emission	PASS	Meet the requirement of limit. Minimum passing margin is -2.89dB at 0.388MHz.
15.407(b/1/2/3) (b)(6)	Spurious Emissions	PASS	Meet the requirement of limit. Minimum passing margin is -1.5dB at 45.45MHz.
15.407(a/1/2)	Peak Transmit Power	PASS	Meet the requirement of limit.
15.407(a)(6)	Peak Power Excursion	PASS	Meet the requirement of limit.
15.407(a/1/2)	Peak Power Spectral Density	PASS	Meet the requirement of limit.
15.407(g)	Frequency Stability	PASS	Meet the requirement of limit.
15.203	Antenna Requirement	PASS	Antenna connector is UFL not a standard connector.

### 2.1 MEASUREMENT UNCERTAINTY

Where relevant, the following measurement uncertainty levels have been estimated for tests performed on the EUT as specified in CISPR 16-4-2:

MEASUREMENT	FREQUENCY	UNCERTAINTY
Conducted emissions	9kHz~30MHz	2.44 dB
Radiated emissions	30MHz ~ 200MHz	3.34 dB
	200MHz ~1000MHz	3.35 dB
	1GHz ~ 18GHz	2.26 dB
	18GHz ~ 40GHz	1.94 dB

This uncertainty represents an expanded uncertainty expressed at approximately the 95% confidence level using a coverage factor of  $k = 2$ .

### 3. GENERAL INFORMATION

#### 3.1 GENERAL DESCRIPTION OF EUT

<b>EUT</b>	Wireless 802.11 abgn Router
<b>MODEL NO.</b>	AP-8100
<b>POWER SUPPLY</b>	48Vdc (POE) 12Vdc (Adapter)
<b>MODULATION TYPE</b>	64QAM, 16QAM, QPSK, BPSK
<b>MODULATION TECHNOLOGY</b>	OFDM
<b>TRANSFER RATE</b>	802.11a: 54.0/ 48.0/ 36.0/ 24.0/ 18.0/ 12.0/ 9.0/ 6.0Mbps 802.11n: up to 300.0Mbps
<b>OPERATING FREQUENCY</b>	5180.0 ~ 5240.0MHz
<b>NUMBER OF CHANNEL</b>	4 for 802.11a, 802.11n (20MHz) 2 for 802.11n (40MHz)
<b>OUTPUT POWER</b>	34.5mW
<b>ANTENNA TYPE</b>	Embedded antenna with 4dBi gain
<b>ANTENNA CONNECTOR</b>	UFL
<b>DATA CABLE</b>	NA
<b>I/O PORTS</b>	RJ45
<b>ACCESSORY DEVICES</b>	Adapter

**NOTE:**

1. The frequency bands used in this EUT are listed as follows:

Frequency Band (MHz)	2412~2462	5180~5240	5745~5825
802.11b	√		
802.11g	√		
802.11a		√	√
802.11n (20MHz)	√	√	√
802.11n (40MHz)	√	√	√

2. The EUT incorporates a MIMO function. Physically, the EUT provides 2 completed transmitters and 2 receivers.

MODULATION MODE	TX FUNCTION
802.11b	2TX
802.11g	2TX
802.11a	2TX
802.11n (20MHz)	2TX
802.11n (40MHz)	2TX

3. The EUT were powered by the following adapter and POE.

<b>ADAPTER</b>	
<b>BRAND:</b>	Powertron
<b>MODEL:</b>	PA1015-2I/PA1015-2I120125
<b>INPUT:</b>	100-240Vac~, 50-60Hz, 0.4A
<b>OUTPUT:</b>	12Vdc, 1.25A, 15W
<b>POWER LINE:</b>	1.5m non-shielded cable w/o core

<b>POE'S ADAPTER</b>	
<b>BRAND:</b>	Powertron
<b>MODEL:</b>	PA1024-4T1
<b>OUTPUT:</b>	48Vdc, 0.5A, 24W

<b>POE</b>	
<b>BRAND:</b>	EnGenius
<b>MODEL:</b>	EPE-48GR

\*\*POE & POE'S adapter as above are provided as support unit only.

4. The above EUT information is declared by manufacturer and for more detailed features description, please refer to the manufacturer's specifications or user's manual.

### 3.2 DESCRIPTION OF TEST MODES

4 channels are provided for 802.11a, 802.11n (20MHz):

<b>CHANNEL</b>	<b>FREQUENCY</b>	<b>CHANNEL</b>	<b>FREQUENCY</b>
36	5180MHz	44	5220MHz
40	5200MHz	48	5240MHz

2 channels are provided for 802.11n (40MHz):

<b>CHANNEL</b>	<b>FREQUENCY</b>	<b>CHANNEL</b>	<b>FREQUENCY</b>
38	5190MHz	46	5230MHz



### 3.2.1 CONFIGURATION OF SYSTEM UNDER TEST

#### TEST MODE A

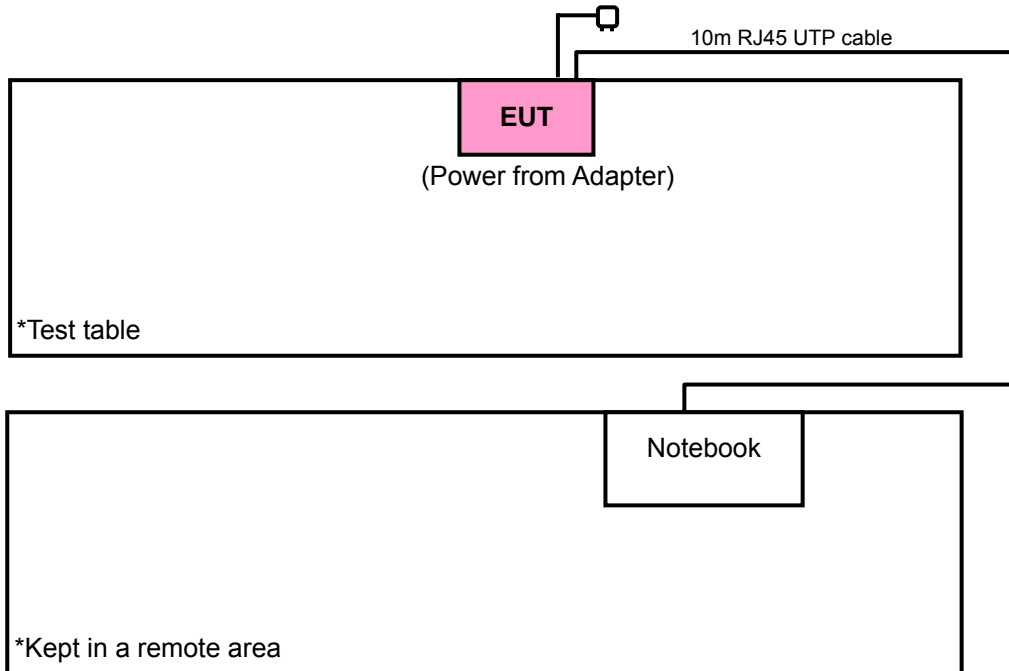

#### TEST MODE B

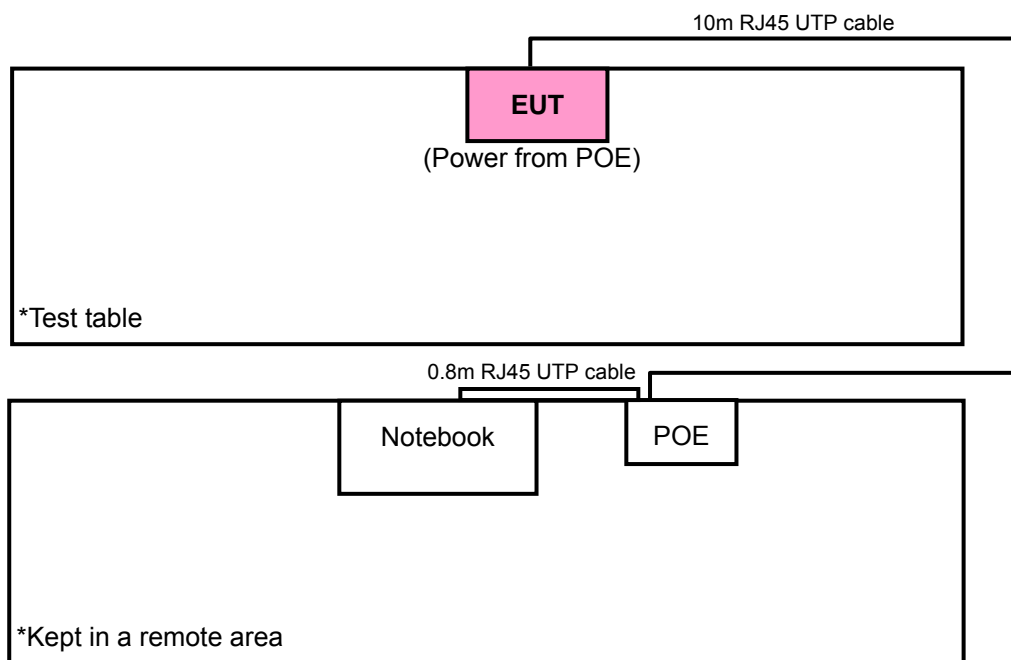

### 3.2.2 DESCRIPTION OF SUPPORT UNITS

The EUT has been tested as an independent unit together with other necessary accessories or support units. The following support units or accessories were used to form a representative test configuration during the tests.

NO.	PRODUCT	BRAND	MODEL NO.	SERIAL NO.	FCC ID
1	NOTEBOOK	DELL	D600	CN-0G5152-48643-487-0068	NA

NO.	SIGNAL CABLE DESCRIPTION OF THE ABOVE SUPPORT UNITS
1	10m RJ45 UTP cable.

**NOTE:**

1. All power cords of the above support units are non shielded (1.8m).
2. Items 1 acted as communication partners to transfer data.

### 3.2.3 TEST MODE APPLICABILITY AND TESTED CHANNEL DETAIL

EUT CONFIGURE MODE	APPLICABLE TO				DESCRIPTION
	RE $\geq$ 1G	RE $<$ 1G	PLC	APCM	
A	√	√	√	√	Power from AC Adapter
B	-	√	√	-	Power from POE

Where **RE $\geq$ 1G**: Radiated Emission above 1GHz      **RE $<$ 1G**: Radiated Emission below 1GHz  
**PLC**: Power Line Conducted Emission      **APCM**: Antenna Port Conducted Measurement  
**NOTE**: "-" means no effect.

#### RADIATED EMISSION TEST (ABOVE 1GHz):

- Pre-Scan has been conducted to determine the worst-case mode from all possible combinations between available modulations, data rates and antenna ports (if EUT with antenna diversity architecture).
- Following channel(s) was (were) selected for the final test as listed below.

EUT CONFIGURE MODE	MODE	AVAILABLE CHANNEL	TESTED CHANNEL	MODULATION TECHNOLOGY	MODULATION TYPE	DATA RATE (Mbps)
A	802.11a	36 to 48	36, 40, 48	OFDM	BPSK	6.0
A	802.11n (20MHz)	36 to 48	36, 40, 48	OFDM	BPSK	7.2
A	802.11n (40MHz)	38 to 46	38, 46	OFDM	BPSK	15.0

#### RADIATED EMISSION TEST (BELOW 1GHz):

- Pre-Scan has been conducted to determine the worst-case mode from all possible combinations between available modulations, data rates and antenna ports (if EUT with antenna diversity architecture).
- Following channel(s) was (were) selected for the final test as listed below.

EUT CONFIGURE MODE	MODE	AVAILABLE CHANNEL	TESTED CHANNEL	MODULATION TECHNOLOGY	MODULATION TYPE	DATA RATE (Mbps)
A & B	802.11n (20MHz)	36 to 48	48	OFDM	BPSK	7.2

#### POWER LINE CONDUCTED EMISSION TEST:

- Pre-Scan has been conducted to determine the worst-case mode from all possible combinations between available modulations, data rates and antenna ports (if EUT with antenna diversity architecture).
- Following channel(s) was (were) selected for the final test as listed below.

EUT CONFIGURE MODE	MODE	AVAILABLE CHANNEL	TESTED CHANNEL	MODULATION TECHNOLOGY	MODULATION TYPE	DATA RATE (Mbps)
A & B	802.11n (20MHz)	36 to 48	48	OFDM	BPSK	7.2

**BANDEDGE MEASUREMENT:**

- Pre-Scan has been conducted to determine the worst-case mode from all possible combinations between available modulations, data rates and antenna ports (if EUT with antenna diversity architecture).
- Following channel(s) was (were) selected for the final test as listed below.

EUT CONFIGURE MODE	MODE	AVAILABLE CHANNEL	TESTED CHANNEL	MODULATION TECHNOLOGY	MODULATION TYPE	DATA RATE (Mbps)
A	802.11a	36 to 48	36, 48	OFDM	BPSK	6.0
A	802.11n (20MHz)	36 to 48	36, 48	OFDM	BPSK	7.2
A	802.11n (40MHz)	38 to 46	38, 46	OFDM	BPSK	15.0

**ANTENNA PORT CONDUCTED MEASUREMENT:**

- This item includes all test value of each mode, but only includes spectrum plot of worst value of each mode.
- Pre-Scan has been conducted to determine the worst-case mode from all possible combinations between available modulations, data rates and antenna ports (if EUT with antenna diversity architecture).
- Following channel(s) was (were) selected for the final test as listed below.

EUT CONFIGURE MODE	MODE	AVAILABLE CHANNEL	TESTED CHANNEL	MODULATION TECHNOLOGY	MODULATION TYPE	DATA RATE (Mbps)
A	802.11a	36 to 48	36, 40, 48	OFDM	BPSK	6.0
A	802.11n (20MHz)	36 to 48	36, 40, 48	OFDM	BPSK	7.2
A	802.11n (40MHz)	38 to 46	38, 46	OFDM	BPSK	15.0

**TEST CONDITION:**

APPLICABLE TO	ENVIRONMENTAL CONDITIONS	INPUT POWER	TESTED BY
RE $\geq$ 1G	25deg. C, 65%RH	120Vac, 60Hz	Kay Wu
RE $<$ 1G	25deg. C, 65%RH	120Vac, 60Hz 48Vdc	Kay Wu
PLC	24deg. C, 65%RH	120Vac, 60Hz 48Vdc	Peter Lin
APCM	25deg. C, 65%RH	120Vac, 60Hz	Kay Wu

### **3.3 GENERAL DESCRIPTION OF APPLIED STANDARDS**

The EUT is a RF Product. According to the specifications of the manufacturer, it must comply with the requirements of the following standards:

**FCC Part 15, Subpart E (15.407)**

**ANSI C63.10-2009**

All test items have been performed and recorded as per the above standards.

**NOTE:** The EUT is also considered as a kind of computer peripheral, because the connection to computer is necessary for typical use. It has been verified to comply with the requirements of FCC Part 15, Subpart B, Class B (DoC). The test report has been issued separately.

## 4. TEST TYPES AND RESULTS

### 4.1 RADIATED EMISSION MEASUREMENT

#### 4.1.1 LIMITS OF RADIATED EMISSION MEASUREMENT

Radiated emissions which fall in the restricted bands must comply with the radiated emission limits specified as below table:

FREQUENCIES (MHz)	FIELD STRENGTH (microvolts/meter)	MEASUREMENT DISTANCE (meters)
0.009 ~ 0.490	2400/F(kHz)	300
0.490 ~ 1.705	24000/F(kHz)	30
1.705 ~ 30.0	30	30
30 ~ 88	100	3
88 ~ 216	150	3
216 ~ 960	200	3
Above 960	500	3

**NOTE:**

1. The lower limit shall apply at the transition frequencies.
2. Emission level (dBuV/m) = 20 log Emission level (uV/m).
3. For frequencies above 1000MHz, the field strength limits are based on average detector, however, the peak field strength of any emission shall not exceed the maximum permitted average limits, specified above by more than 20dB under any condition of modulation.

#### 4.1.2 LIMITS OF UNWANTED EMISSION OUT OF THE RESTRICTED BANDS

FREQUENCIES (MHz)	EIRP LIMIT (dBm)	EQUIVALENT FIELD STRENGTH AT 3m (dBµV/m) *NOTE 3
	PK	PK
5150 ~ 5250	-27	68.3

**NOTE:** The following formula is used to convert the equipment isotropic radiated power (eirp) to field strength:

$$E = \frac{1000000\sqrt{30P}}{3} \mu\text{V/m, where P is the eirp (Watts).}$$

#### 4.1.3 TEST INSTRUMENTS

DESCRIPTION & MANUFACTURER	MODEL NO.	SERIAL NO.	DATE OF CALIBRATION	DUE DATE OF CALIBRATION
Test Receiver ROHDE & SCHWARZ	ESIB7	100212	Aug. 02, 2011	Aug. 01, 2012
Spectrum Analyzer ROHDE & SCHWARZ	FSP 40	100041	Jul. 21, 2011	Jul. 20, 2012
BILOG Antenna SCHWARZBECK	VULB9168	9168-160	Apr. 13, 2011	Apr. 12, 2012
HORN Antenna SCHWARZBECK	9120D	209	Aug. 25, 2011	Aug. 24, 2012
HORN Antenna SCHWARZBECK	BBHA 9170	BBHA9170243	Dec. 27, 2010	Dec. 26, 2011
Preamplifier Agilent	8447D	2944A10633	Oct. 29, 2011	Oct. 28, 2012
Preamplifier Agilent	8449B	3008A01964	Oct. 29, 2011	Oct. 28, 2012
RF signal cable HUBER+SUHNNER	SUCOFLEX 104	295014/4	Aug. 19, 2011	Aug. 18, 2012
RF signal cable HUBER+SUHNNER	SUCOFLEX 104	12738/6	Aug. 19, 2011	Aug. 18, 2012
Software ADT.	ADT_Radiated_ V7.6.15.9.2	NA	NA	NA
Antenna Tower inn-co GmbH	MA 4000	013303	NA	NA
Antenna Tower Controller inn-co GmbH	CO2000	017303	NA	NA
Turn Table ADT.	TT100.	TT93021703	NA	NA
Turn Table Controller ADT.	SC100.	SC93021703	NA	NA
26GHz ~ 40GHz Amplifier	EM26400	815221	Oct. 29, 2011	Oct. 28, 2012
High Speed Peak Power Meter	ML2495A	0842014	Apr. 26, 2011	Apr. 25, 2012
Power Sensor	MA2411B	0738404	Apr. 26, 2011	Apr. 25, 2012

- NOTE:**
1. The calibration interval of the above test instruments is 12 months and the calibrations are traceable to NML/ROC and NIST/USA.
  2. The test was performed in HwaYa Chamber 3.
  3. The horn antenna and HP preamplifier (model: 8449B) are used only for the measurement of emission frequency above 1GHz if tested.
  4. The FCC Site Registration No. is 988962.
  5. The IC Site Registration No. is IC 7450F-3.

#### 4.1.4 TEST PROCEDURES

- a. The EUT was placed on the top of a rotating table 0.8 meters above the ground at a 3 meter semi-anechoic chamber. The table was rotated 360 degrees to determine the position of the highest radiation.
- b. The EUT was set 3 meters away from the interference-receiving antenna, which was mounted on the top of a variable-height antenna tower.
- c. The antenna is a broadband antenna, and its height is varied from one meter to four meters above the ground to determine the maximum value of the field strength. Both horizontal and vertical polarizations of the antenna are set to make the measurement.
- d. For each suspected emission, the EUT was arranged to its worst case and then the antenna was tuned to heights from 1 meter to 4 meters and the rotatable table was turned from 0 degrees to 360 degrees to find the maximum reading.
- e. The test-receiver system was set to Peak Detect Function and Specified Bandwidth with Maximum Hold Mode.
- f. If the emission level of the EUT in peak mode was 10dB lower than the limit specified, then testing could be stopped and the peak values of the EUT would be reported. Otherwise the emissions that did not have 10dB margin would be re-tested one by one using peak, quasi-peak or average method as specified and then reported in a data sheet.

**NOTE:**

1. The resolution bandwidth and video bandwidth of test receiver/spectrum analyzer is 120kHz for Peak detection (PK) and Quasi-peak detection (QP) at frequency below 1GHz.
2. The resolution bandwidth of test receiver/spectrum analyzer is 1MHz and video bandwidth is 3MHz for Peak detection at frequency above 1GHz.
3. The resolution bandwidth of test receiver/spectrum analyzer is 1MHz and the video bandwidth is 10Hz for Average detection (AV) at frequency above 1GHz.
4. All modes of operation were investigated and the worst-case emissions are reported.

#### 4.1.5 DEVIATION FROM TEST STANDARD

No deviation.



#### 4.1.6 TEST SETUP

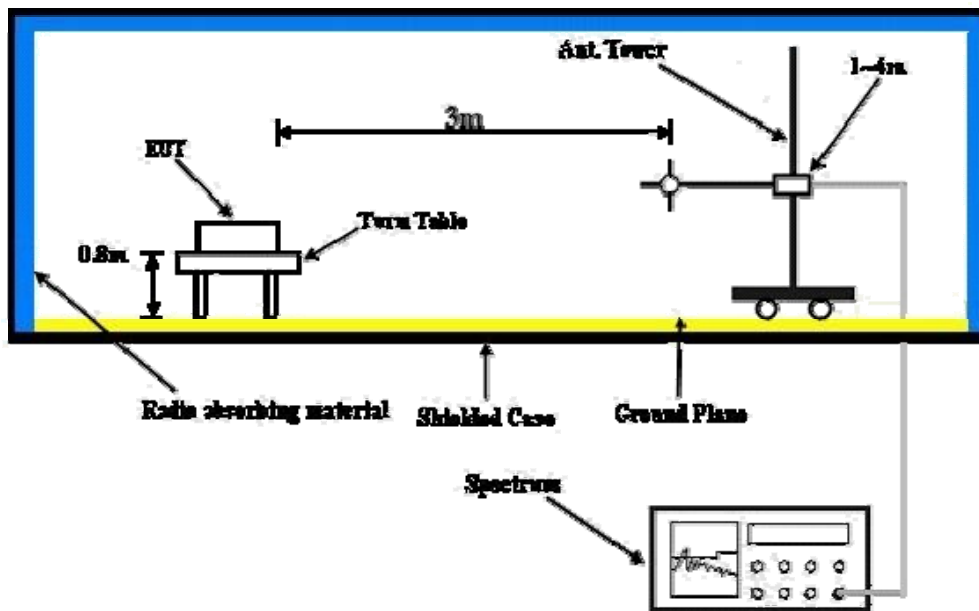

For the actual test configuration, please refer to the attached file (Test Setup Photo).

#### 4.1.7 EUT OPERATING CONDITION

- Placed the EUT on the testing table.
- Prepared notebook outside of testing area to act as communication partners.
- The communication partners connected with EUT via a RJ45 cable and run a test program (provided by manufacturer) to enable EUT under transmission condition continuously at specific channel frequency.
- The necessary accessories enable the system in full functions

#### 4.1.8 TEST RESULTS

##### ABOVE 1GHz: 802.11a

EUT TEST CONDITION		MEASUREMENT DETAIL	
CHANNEL	Channel 36	FREQUENCY RANGE	1 ~ 40GHz
INPUT POWER (SYSTEM)	120Vac, 60 Hz	DETECTOR FUNCTION	Peak (PK) Average (AV)
ENVIRONMENTAL CONDITIONS	25deg. C, 65%RH	TESTED BY	Kay Wu

ANTENNA POLARITY & TEST DISTANCE: HORIZONTAL AT 3 M								
NO.	FREQ. (MHz)	EMISSION LEVEL (dBuV/m)	LIMIT (dBuV/m)	MARGIN (dB)	ANTENNA HEIGHT (m)	TABLE ANGLE (Degree)	RAW VALUE (dBuV)	CORRECTION FACTOR (dB/m)
1	5104.00	52.9 PK	74.0	-21.1	1.04 H	185	15.50	37.40
2	5104.00	44.3 AV	54.0	-9.7	1.04 H	185	6.90	37.40
3	5150.00	48.4 PK	74.0	-25.6	1.04 H	185	10.90	37.50
4	5150.00	38.5 AV	54.0	-15.5	1.04 H	185	1.00	37.50
5	*5180.00	101.7 PK			1.01 H	188	64.20	37.50
6	*5180.00	90.7 AV			1.01 H	188	53.20	37.50
7	#10360.00	56.8 PK	68.3	-11.5	1.00 H	125	8.50	48.30
ANTENNA POLARITY & TEST DISTANCE: VERTICAL AT 3 M								
NO.	FREQ. (MHz)	EMISSION LEVEL (dBuV/m)	LIMIT (dBuV/m)	MARGIN (dB)	ANTENNA HEIGHT (m)	TABLE ANGLE (Degree)	RAW VALUE (dBuV)	CORRECTION FACTOR (dB/m)
1	5104.00	58.9 PK	74.0	-15.1	1.10 V	178	21.50	37.40
2	5104.00	50.7 AV	54.0	-3.3	1.10 V	178	13.30	37.40
3	5150.00	52.8 PK	74.0	-21.2	1.10 V	178	15.30	37.50
4	5150.00	43.2 AV	54.0	-10.8	1.10 V	178	5.70	37.50
5	*5180.00	105.4 PK			1.00 V	351	67.90	37.50
6	*5180.00	94.1 AV			1.00 V	351	56.60	37.50
7	#10360.00	56.3 PK	68.3	-12.0	1.00 V	360	8.00	48.30

- REMARKS:**
1. Emission level (dBuV/m) = Raw Value (dBuV) + Correction Factor (dB/m).
  2. Correction Factor (dB/m) = Antenna Factor (dB/m) + Cable Factor (dB).
  3. The other emission levels were very low against the limit.
  4. Margin value = Emission level – Limit value.
  5. “ \* “: Fundamental frequency.
  6. “#”:The radiated frequency is out the restricted band.

EUT TEST CONDITION		MEASUREMENT DETAIL	
CHANNEL	Channel 40	FREQUENCY RANGE	1 ~ 40GHz
INPUT POWER (SYSTEM)	120Vac, 60 Hz	DETECTOR FUNCTION	Peak (PK) Average (AV)
ENVIRONMENTAL CONDITIONS	25deg. C, 65%RH	TESTED BY	Kay Wu

ANTENNA POLARITY & TEST DISTANCE: HORIZONTAL AT 3 M								
NO.	FREQ. (MHz)	EMISSION LEVEL (dBuV/m)	LIMIT (dBuV/m)	MARGIN (dB)	ANTENNA HEIGHT (m)	TABLE ANGLE (Degree)	RAW VALUE (dBuV)	CORRECTION FACTOR (dB/m)
1	5104.00	53.4 PK	74.0	-20.6	1.12 H	360	16.00	37.40
2	5104.00	44.7 AV	54.0	-9.3	1.12 H	360	7.30	37.40
3	5150.00	49.6 PK	74.0	-24.4	1.00 H	347	12.10	37.50
4	5150.00	38.3 AV	54.0	-15.7	1.00 H	347	0.80	37.50
5	*5200.00	102.1 PK			1.05 H	214	64.60	37.50
6	*5200.00	91.0 AV			1.05 H	214	53.50	37.50
7	#10400.00	57.3 PK	68.3	-11.0	1.00 H	221	8.90	48.40
ANTENNA POLARITY & TEST DISTANCE: VERTICAL AT 3 M								
NO.	FREQ. (MHz)	EMISSION LEVEL (dBuV/m)	LIMIT (dBuV/m)	MARGIN (dB)	ANTENNA HEIGHT (m)	TABLE ANGLE (Degree)	RAW VALUE (dBuV)	CORRECTION FACTOR (dB/m)
1	5104.00	59.7 PK	74.0	-14.3	1.20 V	314	22.30	37.40
2	5104.00	51.3 AV	54.0	-2.7	1.20 V	314	13.90	37.40
3	5150.00	51.9 PK	74.0	-22.1	1.10 V	241	14.40	37.50
4	5150.00	45.3 AV	54.0	-8.7	1.10 V	241	7.80	37.50
5	*5200.00	105.3 PK			1.10 V	154	67.80	37.50
6	*5200.00	94.3 AV			1.10 V	154	56.80	37.50
7	#10400.00	59.0 PK	68.3	-9.3	1.00 V	164	10.60	48.40

- REMARKS:**
1. Emission level (dBuV/m) = Raw Value (dBuV) + Correction Factor (dB/m).
  2. Correction Factor (dB/m) = Antenna Factor (dB/m) + Cable Factor (dB).
  3. The other emission levels were very low against the limit.
  4. Margin value = Emission level – Limit value.
  5. “ \* “: Fundamental frequency.
  6. “#“: The radiated frequency is out the restricted band.



EUT TEST CONDITION		MEASUREMENT DETAIL	
CHANNEL	Channel 48	FREQUENCY RANGE	1 ~ 40GHz
INPUT POWER (SYSTEM)	120Vac, 60 Hz	DETECTOR FUNCTION	Peak (PK) Average (AV)
ENVIRONMENTAL CONDITIONS	25deg. C, 65%RH	TESTED BY	Kay Wu

ANTENNA POLARITY & TEST DISTANCE: HORIZONTAL AT 3 M								
NO.	FREQ. (MHz)	EMISSION LEVEL (dBuV/m)	LIMIT (dBuV/m)	MARGIN (dB)	ANTENNA HEIGHT (m)	TABLE ANGLE (Degree)	RAW VALUE (dBuV)	CORRECTION FACTOR (dB/m)
1	5104.00	52.1 PK	74.0	-21.9	1.00 H	220	14.70	37.40
2	5104.00	43.9 AV	54.0	-10.1	1.00 H	220	6.50	37.40
3	*5240.00	101.5 PK			1.00 H	213	63.90	37.60
4	*5240.00	90.5 AV			1.00 H	213	52.90	37.60
5	5350.00	45.0 PK	74.0	-29.0	1.00 H	168	7.20	37.80
6	5350.00	35.2 AV	54.0	-18.8	1.00 H	168	-2.60	37.80
7	#10480.00	58.1 PK	68.3	-10.2	1.00 H	157	9.60	48.50
ANTENNA POLARITY & TEST DISTANCE: VERTICAL AT 3 M								
NO.	FREQ. (MHz)	EMISSION LEVEL (dBuV/m)	LIMIT (dBuV/m)	MARGIN (dB)	ANTENNA HEIGHT (m)	TABLE ANGLE (Degree)	RAW VALUE (dBuV)	CORRECTION FACTOR (dB/m)
1	5104.00	53.6 PK	74.0	-20.4	1.00 V	114	16.20	37.40
2	5104.00	45.8 AV	54.0	-8.2	1.00 V	114	8.40	37.40
3	*5240.00	105.7 PK			1.00 V	312	68.10	37.60
4	*5240.00	94.6 AV			1.00 V	312	57.00	37.60
5	5350.00	47.2 PK	74.0	-26.8	1.00 V	232	9.40	37.80
6	5350.00	37.4 AV	54.0	-16.6	1.00 V	232	-0.40	37.80
7	#10480.00	58.9 PK	68.3	-9.4	1.00 V	225	10.40	48.50

- REMARKS:**
1. Emission level (dBuV/m) = Raw Value (dBuV) + Correction Factor (dB/m).
  2. Correction Factor (dB/m) = Antenna Factor (dB/m) + Cable Factor (dB).
  3. The other emission levels were very low against the limit.
  4. Margin value = Emission level – Limit value.
  5. “ \* “: Fundamental frequency.
  6. “#”: The radiated frequency is out the restricted band.



A D T

802.11n (20MHz)

EUT TEST CONDITION		MEASUREMENT DETAIL	
CHANNEL	Channel 36	FREQUENCY RANGE	1 ~ 40GHz
INPUT POWER (SYSTEM)	120Vac, 60 Hz	DETECTOR FUNCTION	Peak (PK) Average (AV)
ENVIRONMENTAL CONDITIONS	25deg. C, 65%RH	TESTED BY	Kay Wu

**ANTENNA POLARITY & TEST DISTANCE: HORIZONTAL AT 3 M**

NO.	FREQ. (MHz)	EMISSION LEVEL (dBuV/m)	LIMIT (dBuV/m)	MARGIN (dB)	ANTENNA HEIGHT (m)	TABLE ANGLE (Degree)	RAW VALUE (dBuV)	CORRECTION FACTOR (dB/m)
1	5104.00	51.4 PK	74.0	-22.6	1.00 H	131	14.00	37.40
2	5104.00	43.2 AV	54.0	-10.8	1.00 H	131	5.80	37.40
3	5150.00	48.0 PK	74.0	-26.0	1.00 H	124	10.50	37.50
4	5150.00	43.2 AV	54.0	-10.8	1.00 H	124	5.70	37.50
5	*5180.00	101.2 PK			1.00 H	143	63.70	37.50
6	*5180.00	90.3 AV			1.00 H	143	52.80	37.50
7	#10360.00	56.0 PK	68.3	-12.3	1.00 H	310	7.70	48.30

**ANTENNA POLARITY & TEST DISTANCE: VERTICAL AT 3 M**

NO.	FREQ. (MHz)	EMISSION LEVEL (dBuV/m)	LIMIT (dBuV/m)	MARGIN (dB)	ANTENNA HEIGHT (m)	TABLE ANGLE (Degree)	RAW VALUE (dBuV)	CORRECTION FACTOR (dB/m)
1	5104.00	57.2 PK	74.0	-16.8	1.00 V	197	19.80	37.40
2	5104.00	50.4 AV	54.0	-3.6	1.00 V	197	13.00	37.40
3	5150.00	53.2 PK	74.0	-20.8	1.00 V	165	15.70	37.50
4	5150.00	44.1 AV	54.0	-9.9	1.00 V	165	6.60	37.50
5	*5180.00	105.0 PK			1.10 V	210	67.50	37.50
6	*5180.00	93.7 AV			1.10 V	210	56.20	37.50
7	#10360.00	55.2 PK	68.3	-13.1	1.00 V	154	6.90	48.30

- REMARKS:**
1. Emission level (dBuV/m) = Raw Value (dBuV) + Correction Factor (dB/m).
  2. Correction Factor (dB/m) = Antenna Factor (dB/m) + Cable Factor (dB).
  3. The other emission levels were very low against the limit.
  4. Margin value = Emission level – Limit value.
  5. “ \* “: Fundamental frequency.
  6. "#":The radiated frequency is out the restricted band.



EUT TEST CONDITION		MEASUREMENT DETAIL	
CHANNEL	Channel 40	FREQUENCY RANGE	1 ~ 40GHz
INPUT POWER (SYSTEM)	120Vac, 60 Hz	DETECTOR FUNCTION	Peak (PK) Average (AV)
ENVIRONMENTAL CONDITIONS	25deg. C, 65%RH	TESTED BY	Kay Wu

ANTENNA POLARITY & TEST DISTANCE: HORIZONTAL AT 3 M								
NO.	FREQ. (MHz)	EMISSION LEVEL (dBuV/m)	LIMIT (dBuV/m)	MARGIN (dB)	ANTENNA HEIGHT (m)	TABLE ANGLE (Degree)	RAW VALUE (dBuV)	CORRECTION FACTOR (dB/m)
1	5104.00	52.1 PK	74.0	-21.9	1.10 H	214	14.70	37.40
2	5104.00	43.5 AV	54.0	-10.5	1.10 H	214	6.10	37.40
3	5150.00	48.7 PK	74.0	-25.3	1.12 H	231	11.20	37.50
4	5150.00	38.0 AV	54.0	-16.0	1.12 H	231	0.50	37.50
5	*5200.00	101.4 PK			1.10 H	175	63.90	37.50
6	*5200.00	90.1 AV			1.10 H	175	52.60	37.50
7	#10400.00	56.4 PK	68.3	-11.9	1.00 H	142	8.00	48.40
ANTENNA POLARITY & TEST DISTANCE: VERTICAL AT 3 M								
NO.	FREQ. (MHz)	EMISSION LEVEL (dBuV/m)	LIMIT (dBuV/m)	MARGIN (dB)	ANTENNA HEIGHT (m)	TABLE ANGLE (Degree)	RAW VALUE (dBuV)	CORRECTION FACTOR (dB/m)
1	5104.00	58.4 PK	74.0	-15.6	1.00 V	149	21.00	37.40
2	5104.00	50.7 AV	54.0	-3.3	1.00 V	149	13.30	37.40
3	5150.00	52.3 PK	74.0	-21.7	1.00 V	199	14.80	37.50
4	5150.00	46.7 AV	54.0	-7.3	1.00 V	199	9.20	37.50
5	*5200.00	105.1 PK			1.15 V	186	67.60	37.50
6	*5200.00	94.0 AV			1.15 V	186	56.50	37.50
7	#10400.00	58.4 PK	68.3	-9.9	1.10 V	221	10.00	48.40

- REMARKS:**
1. Emission level (dBuV/m) = Raw Value (dBuV) + Correction Factor (dB/m).
  2. Correction Factor (dB/m) = Antenna Factor (dB/m) + Cable Factor (dB).
  3. The other emission levels were very low against the limit.
  4. Margin value = Emission level – Limit value.
  5. “ \* “: Fundamental frequency.
  6. “#”: The radiated frequency is out the restricted band.

EUT TEST CONDITION		MEASUREMENT DETAIL	
CHANNEL	Channel 48	FREQUENCY RANGE	1 ~ 40GHz
INPUT POWER (SYSTEM)	120Vac, 60 Hz	DETECTOR FUNCTION	Peak (PK) Average (AV)
ENVIRONMENTAL CONDITIONS	25deg. C, 65%RH	TESTED BY	Kay Wu

ANTENNA POLARITY & TEST DISTANCE: HORIZONTAL AT 3 M								
NO.	FREQ. (MHz)	EMISSION LEVEL (dBuV/m)	LIMIT (dBuV/m)	MARGIN (dB)	ANTENNA HEIGHT (m)	TABLE ANGLE (Degree)	RAW VALUE (dBuV)	CORRECTION FACTOR (dB/m)
1	5104.00	51.3 PK	74.0	-22.7	1.00 H	142	13.90	37.40
2	5104.00	43.2 AV	54.0	-10.8	1.00 H	142	5.80	37.40
3	*5240.00	101.1 PK			1.00 H	323	63.50	37.60
4	*5240.00	90.0 AV			1.00 H	323	52.40	37.60
5	5350.00	44.1 PK	74.0	-29.9	1.10 H	221	6.30	37.80
6	5350.00	34.3 AV	54.0	-19.7	1.10 H	221	-3.50	37.80
7	#10480.00	57.2 PK	68.3	-11.1	1.10 H	223	8.70	48.50
ANTENNA POLARITY & TEST DISTANCE: VERTICAL AT 3 M								
NO.	FREQ. (MHz)	EMISSION LEVEL (dBuV/m)	LIMIT (dBuV/m)	MARGIN (dB)	ANTENNA HEIGHT (m)	TABLE ANGLE (Degree)	RAW VALUE (dBuV)	CORRECTION FACTOR (dB/m)
1	5104.00	54.7 PK	74.0	-19.3	1.10 V	224	17.30	37.40
2	5104.00	47.3 AV	54.0	-6.7	1.10 V	224	9.90	37.40
3	*5240.00	105.2 PK			1.00 V	269	67.60	37.60
4	*5240.00	94.1 AV			1.00 V	269	56.50	37.60
5	5350.00	46.3 PK	74.0	-27.7	1.00 V	214	8.50	37.80
6	5350.00	37.1 AV	54.0	-16.9	1.00 V	214	-0.70	37.80
7	#10480.00	57.3 PK	68.3	-11.0	1.00 V	245	8.80	48.50

- REMARKS:**
1. Emission level (dBuV/m) = Raw Value (dBuV) + Correction Factor (dB/m).
  2. Correction Factor (dB/m) = Antenna Factor (dB/m) + Cable Factor (dB).
  3. The other emission levels were very low against the limit.
  4. Margin value = Emission level – Limit value.
  5. “ \* “: Fundamental frequency.
  6. “#”: The radiated frequency is out the restricted band.

802.11n (40MHz)

EUT TEST CONDITION		MEASUREMENT DETAIL	
CHANNEL	Channel 38	FREQUENCY RANGE	1 ~ 40GHz
INPUT POWER (SYSTEM)	120Vac, 60 Hz	DETECTOR FUNCTION	Peak (PK) Average (AV)
ENVIRONMENTAL CONDITIONS	25deg. C, 65%RH	TESTED BY	Kay Wu

ANTENNA POLARITY & TEST DISTANCE: HORIZONTAL AT 3 M								
NO.	FREQ. (MHz)	EMISSION LEVEL (dBuV/m)	LIMIT (dBuV/m)	MARGIN (dB)	ANTENNA HEIGHT (m)	TABLE ANGLE (Degree)	RAW VALUE (dBuV)	CORRECTION FACTOR (dB/m)
1	5104.00	52.9 PK	74.0	-21.1	1.05 H	185	15.50	37.40
2	5104.00	44.4 AV	54.0	-9.6	1.05 H	185	7.00	37.40
3	5150.00	55.7 PK	74.0	-18.3	1.02 H	162	18.20	37.50
4	5150.00	42.7 AV	54.0	-11.3	1.02 H	162	5.20	37.50
5	*5190.00	101.5 PK			1.02 H	186	64.00	37.50
6	*5190.00	90.4 AV			1.02 H	186	52.90	37.50
7	5445.00	53.2 PK	74.0	-20.8	1.00 H	171	15.30	37.90
8	5445.00	42.1 AV	54.0	-11.9	1.00 H	171	4.20	37.90
9	#10380.00	57.0 PK	68.3	-11.3	1.00 H	125	8.70	48.30

ANTENNA POLARITY & TEST DISTANCE: VERTICAL AT 3 M								
NO.	FREQ. (MHz)	EMISSION LEVEL (dBuV/m)	LIMIT (dBuV/m)	MARGIN (dB)	ANTENNA HEIGHT (m)	TABLE ANGLE (Degree)	RAW VALUE (dBuV)	CORRECTION FACTOR (dB/m)
1	5104.00	59.4 PK	74.0	-14.6	1.09 V	182	22.00	37.40
2	5104.00	51.0 AV	54.0	-3.0	1.09 V	182	13.60	37.40
3	5150.00	58.5 PK	74.0	-15.5	1.21 V	187	21.00	37.50
4	5150.00	47.9 AV	54.0	-6.1	1.21 V	187	10.40	37.50
5	*5190.00	104.9 PK			1.46 V	349	67.40	37.50
6	*5190.00	94.0 AV			1.46 V	349	56.50	37.50
7	5445.00	59.7 PK	74.0	-14.3	1.01 V	186	21.80	37.90
8	5445.00	49.9 AV	54.0	-4.1	1.01 V	186	12.00	37.90
9	#10380.00	55.9 PK	68.3	-12.4	1.00 V	158	7.60	48.30

- REMARKS:**
1. Emission level (dBuV/m) = Raw Value (dBuV) + Correction Factor (dB/m).
  2. Correction Factor (dB/m) = Antenna Factor (dB/m) + Cable Factor (dB).
  3. The other emission levels were very low against the limit.
  4. Margin value = Emission level – Limit value.
  5. “ \* “: Fundamental frequency.
  6. “#”:The radiated frequency is out the restricted band.





EUT TEST CONDITION		MEASUREMENT DETAIL	
CHANNEL	Channel 46	FREQUENCY RANGE	1 ~ 40GHz
INPUT POWER (SYSTEM)	120Vac, 60 Hz	DETECTOR FUNCTION	Peak (PK) Average (AV)
ENVIRONMENTAL CONDITIONS	25deg. C, 65%RH	TESTED BY	Kay Wu

ANTENNA POLARITY & TEST DISTANCE: HORIZONTAL AT 3 M								
NO.	FREQ. (MHz)	EMISSION LEVEL (dBuV/m)	LIMIT (dBuV/m)	MARGIN (dB)	ANTENNA HEIGHT (m)	TABLE ANGLE (Degree)	RAW VALUE (dBuV)	CORRECTION FACTOR (dB/m)
1	5104.00	51.3 PK	74.0	-22.7	1.00 H	258	13.90	37.40
2	5104.00	43.1 AV	54.0	-10.9	1.00 H	258	5.70	37.40
3	*5190.00	101.2 PK			1.00 H	197	63.70	37.50
4	*5190.00	90.3 AV			1.00 H	197	52.80	37.50
5	5350.00	55.6 PK	74.0	-18.4	1.00 H	159	17.80	37.80
6	5350.00	45.7 AV	54.0	-8.3	1.00 H	159	7.90	37.80
7	#10460.00	56.7 PK	68.3	-11.6	1.00 H	196	8.20	48.50
ANTENNA POLARITY & TEST DISTANCE: VERTICAL AT 3 M								
NO.	FREQ. (MHz)	EMISSION LEVEL (dBuV/m)	LIMIT (dBuV/m)	MARGIN (dB)	ANTENNA HEIGHT (m)	TABLE ANGLE (Degree)	RAW VALUE (dBuV)	CORRECTION FACTOR (dB/m)
1	5104.00	55.7 PK	74.0	-18.3	1.40 V	171	18.30	37.40
2	5104.00	49.3 AV	54.0	-4.7	1.40 V	171	11.90	37.40
3	*5230.00	104.5 PK			1.45 V	348	66.90	37.60
4	*5230.00	93.9 AV			1.45 V	348	56.30	37.60
5	5350.00	58.7 PK	74.0	-15.3	1.41 V	174	20.90	37.80
6	5350.00	48.3 AV	54.0	-5.7	1.41 V	174	10.50	37.80
7	#10460.00	55.7 PK	68.3	-12.6	1.00 V	185	7.20	48.50

- REMARKS:**
1. Emission level (dBuV/m) = Raw Value (dBuV) + Correction Factor (dB/m).
  2. Correction Factor (dB/m) = Antenna Factor (dB/m) + Cable Factor (dB).
  3. The other emission levels were very low against the limit.
  4. Margin value = Emission level – Limit value.
  5. “ \* “: Fundamental frequency.
  6. “#”: The radiated frequency is out the restricted band.



**BELOW 1GHz WORST-CASE DATA : 802.11n (20MHz)**

EUT TEST CONDITION		MEASUREMENT DETAIL	
CHANNEL	Channel 48	FREQUENCY RANGE	Below 1000MHz
INPUT POWER (SYSTEM)	120Vac, 60 Hz	DETECTOR FUNCTION	Quasi-Peak
ENVIRONMENTAL CONDITIONS	25deg. C, 65%RH	TEST MODE	A
TESTED BY	Kay Wu		

ANTENNA POLARITY & TEST DISTANCE: HORIZONTAL AT 3 M								
NO.	FREQ. (MHz)	EMISSION LEVEL (dBuV/m)	LIMIT (dBuV/m)	MARGIN (dB)	ANTENNA HEIGHT (m)	TABLE ANGLE (Degree)	RAW VALUE (dBuV)	CORRECTION FACTOR (dB/m)
1	43.51	30.2 QP	40.0	-9.8	2.00 H	55	15.80	14.40
2	249.60	34.3 QP	46.0	-11.7	1.00 H	250	21.30	13.00
3	360.43	44.2 QP	46.0	-1.8	1.00 H	241	27.80	16.40
4	374.04	40.2 QP	46.0	-5.8	1.00 H	154	23.40	16.80
5	500.42	35.6 QP	46.0	-10.4	2.00 H	217	15.40	20.20
6	624.85	43.9 QP	46.0	-2.1	1.00 H	208	21.00	22.90
ANTENNA POLARITY & TEST DISTANCE: VERTICAL AT 3 M								
NO.	FREQ. (MHz)	EMISSION LEVEL (dBuV/m)	LIMIT (dBuV/m)	MARGIN (dB)	ANTENNA HEIGHT (m)	TABLE ANGLE (Degree)	RAW VALUE (dBuV)	CORRECTION FACTOR (dB/m)
1	45.45	38.5 QP	40.0	-1.5	1.00 V	142	24.10	14.40
2	249.60	29.7 QP	46.0	-16.3	1.00 V	139	16.70	13.00
3	360.43	42.4 QP	46.0	-3.6	1.00 V	184	26.00	16.40
4	374.04	41.5 QP	46.0	-4.5	1.00 V	166	24.70	16.80
5	500.42	32.0 QP	46.0	-14.0	2.00 V	193	11.80	20.20
6	624.85	43.4 QP	46.0	-2.6	1.00 V	88	20.50	22.90

- REMARKS:**
1. Emission level (dBuV/m) = Raw Value (dBuV) + Correction Factor (dB/m).
  2. Correction Factor (dB/m) = Antenna Factor (dB/m) + Cable Factor (dB).
  3. The other emission levels were very low against the limit.
  4. Margin value = Emission level – Limit value.



EUT TEST CONDITION		MEASUREMENT DETAIL	
CHANNEL	Channel 48	FREQUENCY RANGE	Below 1000MHz
INPUT POWER (SYSTEM)	120Vac, 60 Hz	DETECTOR FUNCTION	Quasi-Peak
ENVIRONMENTAL CONDITIONS	25deg. C, 65%RH	TEST MODE	B
TESTED BY	Kay Wu		

ANTENNA POLARITY & TEST DISTANCE: HORIZONTAL AT 3 M								
NO.	FREQ. (MHz)	EMISSION LEVEL (dBuV/m)	LIMIT (dBuV/m)	MARGIN (dB)	ANTENNA HEIGHT (m)	TABLE ANGLE (Degree)	RAW VALUE (dBuV)	CORRECTION FACTOR (dB/m)
1	138.78	29.1 QP	43.5	-14.4	2.00 H	115	15.10	14.00
2	350.71	30.5 QP	46.0	-15.5	1.00 H	157	14.30	16.20
3	360.43	42.5 QP	46.0	-3.5	1.00 H	148	26.10	16.40
4	374.04	29.2 QP	46.0	-16.8	1.00 H	139	12.40	16.80
5	599.58	31.7 QP	46.0	-14.3	3.00 H	106	9.30	22.40
6	720.12	36.7 QP	46.0	-9.3	2.00 H	139	12.40	24.30
ANTENNA POLARITY & TEST DISTANCE: VERTICAL AT 3 M								
NO.	FREQ. (MHz)	EMISSION LEVEL (dBuV/m)	LIMIT (dBuV/m)	MARGIN (dB)	ANTENNA HEIGHT (m)	TABLE ANGLE (Degree)	RAW VALUE (dBuV)	CORRECTION FACTOR (dB/m)
1	43.51	34.2 QP	40.0	-5.8	1.00 V	271	19.80	14.40
2	96.01	27.1 QP	43.5	-16.4	1.00 V	133	17.50	9.60
3	125.17	26.9 QP	43.5	-16.6	1.00 V	1	14.00	12.90
4	348.76	31.7 QP	46.0	-14.3	2.00 V	121	15.60	16.10
5	360.43	38.0 QP	46.0	-8.0	2.00 V	109	21.60	16.40
6	599.58	31.0 QP	46.0	-15.0	1.00 V	247	8.60	22.40

- REMARKS:**
1. Emission level (dBuV/m) = Raw Value (dBuV) + Correction Factor (dB/m).
  2. Correction Factor (dB/m) = Antenna Factor (dB/m) + Cable Factor (dB).
  3. The other emission levels were very low against the limit.
  4. Margin value = Emission level – Limit value.

## 4.2 CONDUCTED EMISSION MEASUREMENT

### 4.2.1 LIMITS OF CONDUCTED EMISSION MEASUREMENT

FREQUENCY OF EMISSION (MHz)	CONDUCTED LIMIT (dB $\mu$ V)	
	Quasi-peak	Average
0.15 ~ 0.5	66 to 56	56 to 46
0.5 ~ 5	56	46
5 ~ 30	60	50

- NOTE:** 1. The lower limit shall apply at the transition frequencies.  
 2. The limit decreases in line with the logarithm of the frequency in the range of 0.15 to 0.50MHz.  
 3. All emanations from a class A/B digital device or system, including any network of conductors and apparatus connected thereto, shall not exceed the level of field strengths specified above.

### 4.2.2 TEST INSTRUMENTS

DESCRIPTION & MANUFACTURER	MODEL NO.	SERIAL NO.	DATE OF CALIBRATION	DUE DATE OF CALIBRATION
Test Receiver ROHDE & SCHWARZ	ESCS30	100288	Oct. 04, 2011	Oct. 03, 2012
RF signal cable Woken	5D-FB	Cable-HYCO2-01	Dec. 30, 2010	Dec. 29, 2011
LISN ROHDE & SCHWARZ	ESH2-Z5	100100	Jan. 06, 2011	Jan. 05, 2012
LISN ROHDE & SCHWARZ	ESH3-Z5	100312	Jul. 07, 2011	Jul. 06, 2012
V-LISN SCHWARZBECK	NNBL 8226-2	8226-142	Jun. 30, 2011	Jun. 29, 2012
LISN ROHDE & SCHWARZ	ENV216	100072	Jun. 10, 2011	Jun. 09, 2012
Software ADT	ADT_Cond_ V7.3.7	NA	NA	NA

- NOTE:** 1. The calibration interval of the above test instruments is 12 months and the calibrations are traceable to NML/ROC and NIST/USA.  
 2. The test was performed in HwaYa Shielded Room 2.  
 3. The VCCI Site Registration No. is C-2047.

#### 4.2.3 TEST PROCEDURES

- a. The EUT was placed 0.4 meters from the conducting wall of the shielded room with EUT being connected to the power mains through a line impedance stabilization network (LISN). Other support units were connected to the power mains through another LISN. The two LISNs provide 50 ohm/ 50uH of coupling impedance for the measuring instrument.
- b. Both lines of the power mains connected to the EUT were checked for maximum conducted interference.
- c. The frequency range from 150kHz to 30MHz was searched. Emission levels under (Limit - 20dB) was not recorded.

**NOTE:** All modes of operation were investigated and the worst-case emissions are reported.

#### 4.2.4 DEVIATION FROM TEST STANDARD

No deviation.

#### 4.2.5 TEST SETUP

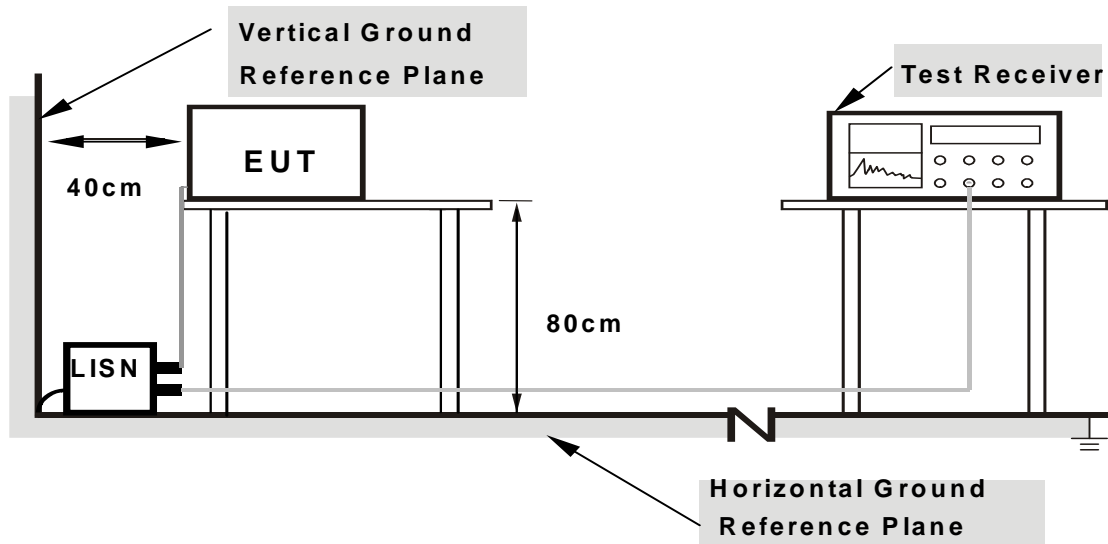

**Note: 1.Support units were connected to second LISN.**

**2.Both of LISNs (AMN) are 80 cm from EUT and at least 80 from other units and other metal planes**

For the actual test configuration, please refer to the attached file (Test Setup Photo).

#### 4.2.6 EUT OPERATING CONDITIONS

Same as 4.1.6.

## 4.2.7 TEST RESULTS

### CONDUCTED WORST-CASE DATA : 802.11a (20MHz)

PHASE	Line 1	6dB BANDWIDTH	9kHz
TEST MODE	A		

No	Freq. [MHz]	Corr. Factor (dB)	Reading Value [dB (uV)]		Emission Level [dB (uV)]		Limit [dB (uV)]		Margin (dB)	
			Q.P.	AV.	Q.P.	AV.	Q.P.	AV.	Q.P.	AV.
1	0.388	0.20	53.19	45.01	53.39	45.21	58.10	48.10	-4.71	-2.89
2	0.662	0.21	41.90	-	42.11	-	56.00	46.00	-13.89	-
3	0.955	0.23	42.07	-	42.30	-	56.00	46.00	-13.70	-
4	2.434	0.28	41.08	-	41.36	-	56.00	46.00	-14.64	-
5	2.637	0.30	41.30	-	41.60	-	56.00	46.00	-14.40	-
6	4.789	0.40	39.30	-	39.70	-	56.00	46.00	-16.30	-

- REMARKS:**
1. Q.P. and AV. are abbreviations of quasi-peak and average individually.
  2. "-": The Quasi-peak reading value also meets average limit and measurement with the average detector is unnecessary.
  3. The emission levels of other frequencies were very low against the limit.
  4. Margin value = Emission level - Limit value
  5. Correction factor = Insertion loss + Cable loss
  6. Emission Level = Correction Factor + Reading Value.

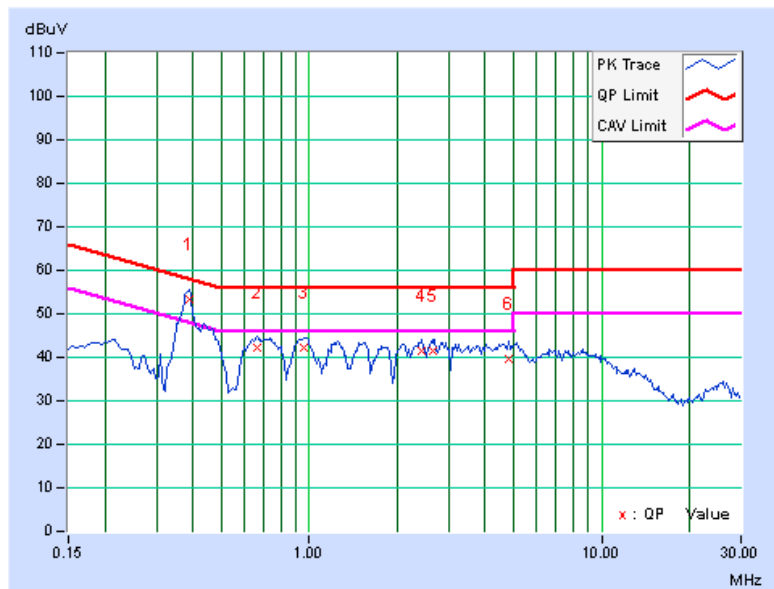

PHASE	Line 2	6dB BANDWIDTH	9kHz
TEST MODE	A		

No	Freq. [MHz]	Corr. Factor (dB)	Reading Value [dB (uV)]		Emission Level [dB (uV)]		Limit [dB (uV)]		Margin (dB)	
			Q.P.	AV.	Q.P.	AV.	Q.P.	AV.	Q.P.	AV.
1	0.383	0.21	47.30	-	47.51	-	58.21	48.21	-10.71	-
2	0.681	0.21	36.32	-	36.53	-	56.00	46.00	-19.47	-
3	0.955	0.21	36.61	-	36.82	-	56.00	46.00	-19.18	-
4	1.266	0.22	36.58	-	36.80	-	56.00	46.00	-19.20	-
5	2.125	0.25	34.87	-	35.12	-	56.00	46.00	-20.88	-
6	2.941	0.29	35.52	-	35.81	-	56.00	46.00	-20.19	-

- REMARKS:**
1. Q.P. and AV. are abbreviations of quasi-peak and average individually.
  2. "-": The Quasi-peak reading value also meets average limit and measurement with the average detector is unnecessary.
  3. The emission levels of other frequencies were very low against the limit.
  4. Margin value = Emission level - Limit value
  5. Correction factor = Insertion loss + Cable loss
  6. Emission Level = Correction Factor + Reading Value.

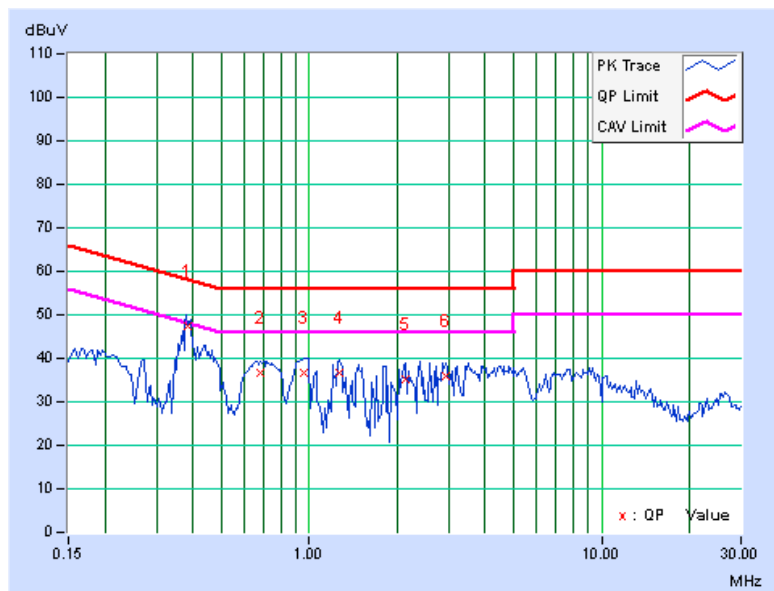



PHASE	Line 1	6dB BANDWIDTH	9kHz
TEST MODE	B		

No	Freq. [MHz]	Corr. Factor (dB)	Reading Value [dB (uV)]		Emission Level [dB (uV)]		Limit [dB (uV)]		Margin (dB)	
			Q.P.	AV.	Q.P.	AV.	Q.P.	AV.	Q.P.	AV.
1	0.170	0.17	57.68	44.98	57.85	45.15	64.98	54.98	-7.14	-9.84
2	0.209	0.17	52.87	-	53.04	-	63.26	53.26	-10.22	-
3	0.494	0.20	50.22	41.42	50.42	41.62	56.10	46.10	-5.68	-4.48
4	1.434	0.24	44.75	-	44.99	-	56.00	46.00	-11.01	-
5	2.191	0.27	44.65	-	44.92	-	56.00	46.00	-11.08	-
6	3.906	0.36	43.51	-	43.87	-	56.00	46.00	-12.13	-

- REMARKS:**
1. Q.P. and AV. are abbreviations of quasi-peak and average individually.
  2. "-": The Quasi-peak reading value also meets average limit and measurement with the average detector is unnecessary.
  3. The emission levels of other frequencies were very low against the limit.
  4. Margin value = Emission level - Limit value
  5. Correction factor = Insertion loss + Cable loss
  6. Emission Level = Correction Factor + Reading Value.

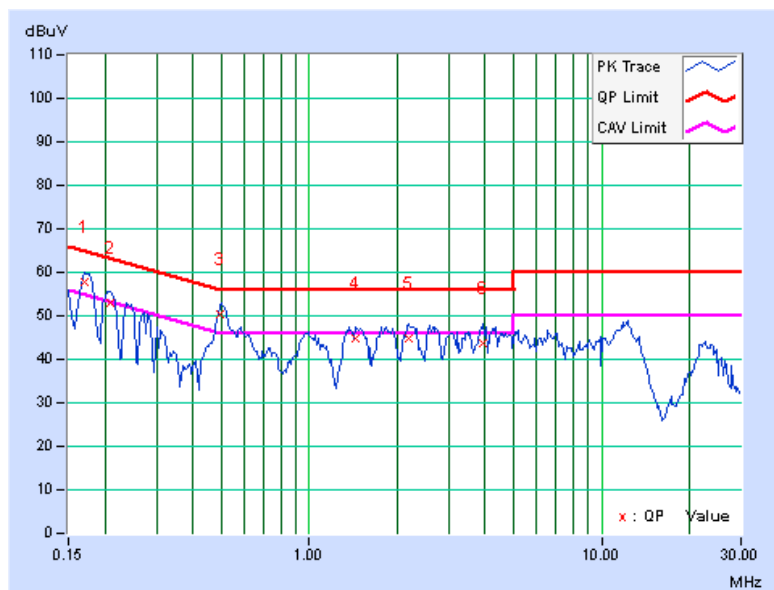

PHASE	Line 2	6dB BANDWIDTH	9kHz
TEST MODE	B		

No	Freq. [MHz]	Corr. Factor (dB)	Reading Value		Emission Level		Limit		Margin	
			[dB (uV)]		[dB (uV)]		[dB (uV)]		(dB)	
			Q.P.	AV.	Q.P.	AV.	Q.P.	AV.	Q.P.	AV.
1	0.170	0.19	57.56	44.29	57.75	44.48	64.98	54.98	-7.23	-10.50
2	0.502	0.21	49.04	39.04	49.25	39.25	56.00	46.00	-6.75	-6.75
3	2.234	0.25	46.45	39.75	46.70	40.00	56.00	46.00	-9.30	-6.00
4	2.633	0.27	46.02	39.56	46.29	39.83	56.00	46.00	-9.71	-6.17
5	4.238	0.36	44.33	-	44.69	-	56.00	46.00	-11.31	-
6	12.117	0.69	51.06	46.03	51.75	46.72	60.00	50.00	-8.25	-3.28

- REMARKS:**
1. Q.P. and AV. are abbreviations of quasi-peak and average individually.
  2. "-": The Quasi-peak reading value also meets average limit and measurement with the average detector is unnecessary.
  3. The emission levels of other frequencies were very low against the limit.
  4. Margin value = Emission level - Limit value
  5. Correction factor = Insertion loss + Cable loss
  6. Emission Level = Correction Factor + Reading Value.

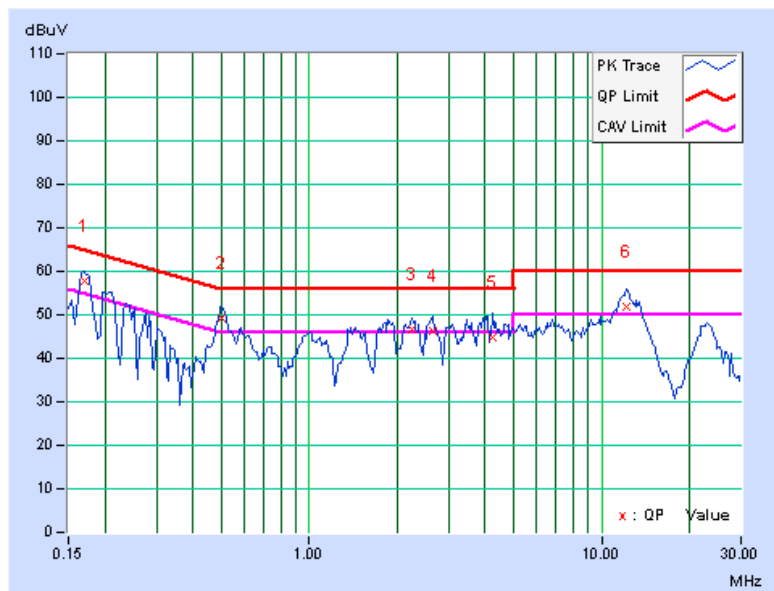

### 4.3 MAXIMUM CONDUCTED OUTPUT POWER MEASUREMENT

#### 4.3.1 LIMITS OF MAXIMUM CONDUCTED OUTPUT POWER MEASUREMENT

FREQUENCY BAND	LIMIT
5.15 ~ 5.25GHz	The lesser of 50mW (17dBm) or 4dBm + 10logB

**NOTE:** Where B is the 26dB emission bandwidth in MHz.

#### 4.3.2 TEST SETUP

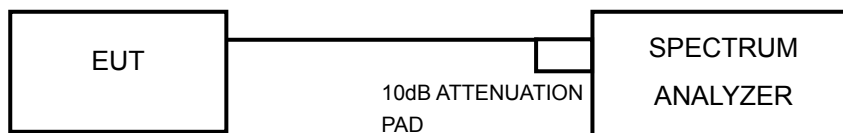

#### 4.3.3 TEST INSTRUMENTS

Refer to section 4.1.3 to get information of above instrument.

#### 4.3.4 TEST PROCEDURE

1. Set RBW = 1 MHz, VBW = 3 MHz.
2. Set sweep time = 26 S.
3. Set detector = RMS.
4. Perform a single sweep.
5. Compute power by integrating the spectrum across the 26 dB EBW of the signal

#### 4.3.5 DEVIATION FROM TEST STANDARD

No deviation.

#### 4.3.6 EUT OPERATING CONDITIONS

The software provided by client to enable the EUT under transmission condition continuously at specific channel frequencies individually.

### 4.3.7 TEST RESULTS

#### POWER OUTPUT: 802.11a

CHAN.	FREQUENCY (MHz)	PEAK POWER (dBm)		TOTAL POWER (mW)	TOTAL POWER (dBm)	LIMIT (dBm)	PASS / FAIL
		CHAIN 0	CHAIN 1				
36	5180	9.14	10.26	18.8	12.7	16	PASS
40	5200	9.31	11.23	21.8	13.4	16	PASS
48	5240	9.09	11.04	20.8	13.2	16	PASS

**NOTE:** Directional gain =  $4\text{dBi} + 10\log(2) = 7\text{dBi} > 6\text{dBi}$ , so the limit shall be reduced to  $17 - (7 - 6) = 16\text{dBm}$ .

#### CHAIN 1: CH 40

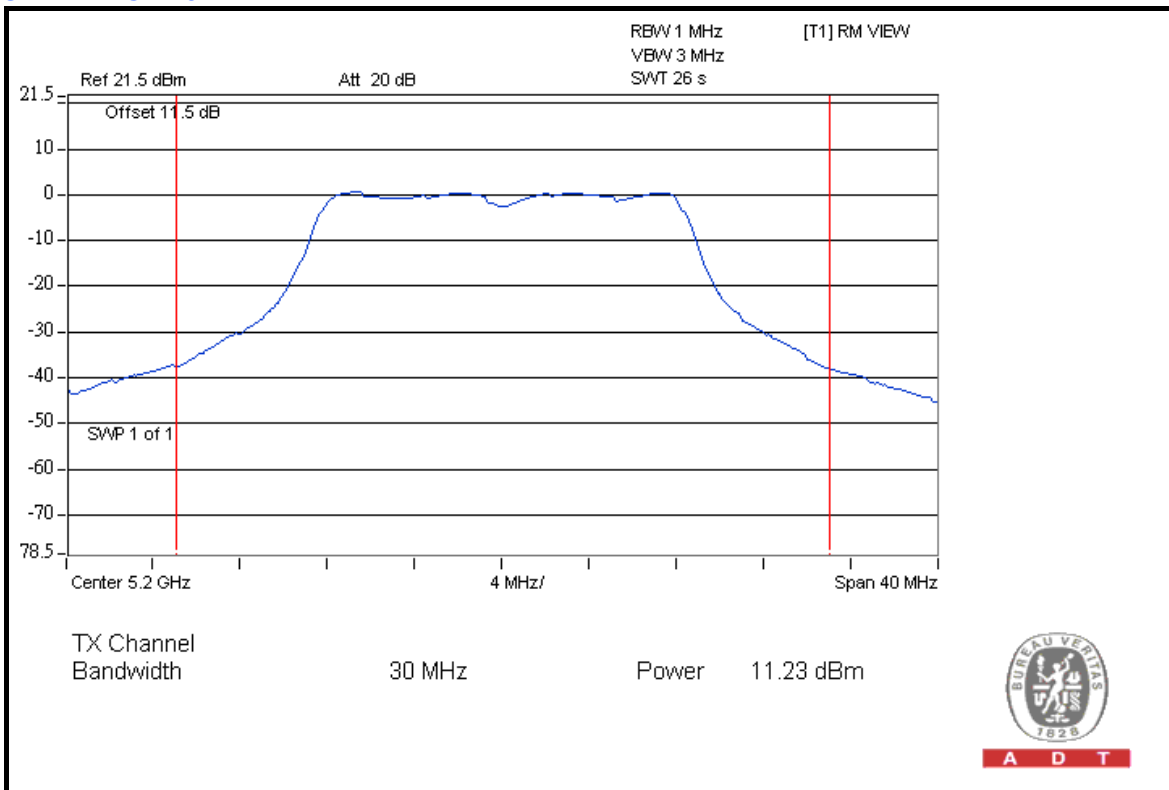



A D T

### 802.11n (20MHz)

CHAN.	FREQUENCY (MHz)	PEAK POWER (dBm)		TOTAL POWER (mW)	TOTAL POWER (dBm)	LIMIT (dBm)	PASS / FAIL
		CHAIN 0	CHAIN 1				
36	5180	8.78	11.14	20.6	13.1	17	PASS
40	5200	9.2	10.87	20.5	13.1	17	PASS
48	5240	9.42	11.50	22.9	13.6	17	PASS

### CHAIN 1: CH 48

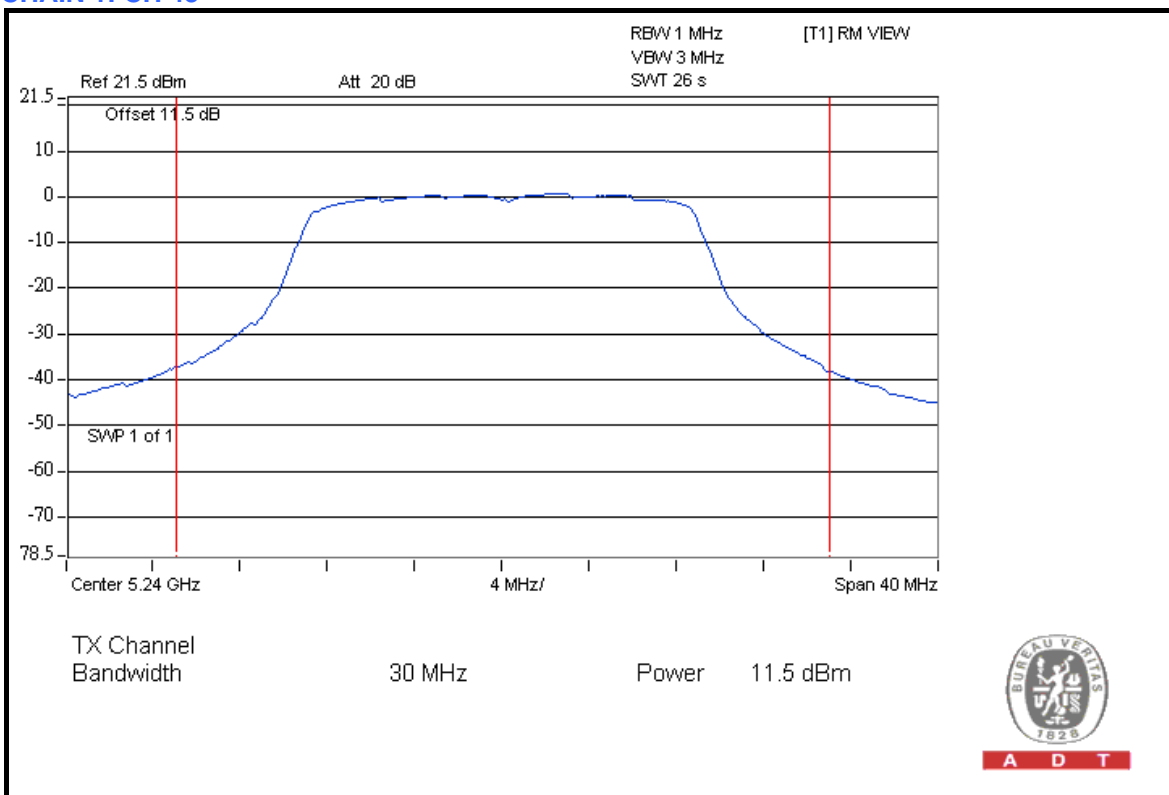



A D T

### 802.11n (40MHz)

CHAN.	FREQUENCY (MHz)	PEAK POWER (dBm)		TOTAL POWER (mW)	TOTAL POWER (dBm)	LIMIT (dBm)	PASS / FAIL
		CHAIN 0	CHAIN 1				
38	5190	11.43	13.14	34.5	15.4	17	PASS
46	5230	11.33	13.02	33.6	15.3	17	PASS

### CHAIN 1: CH 38

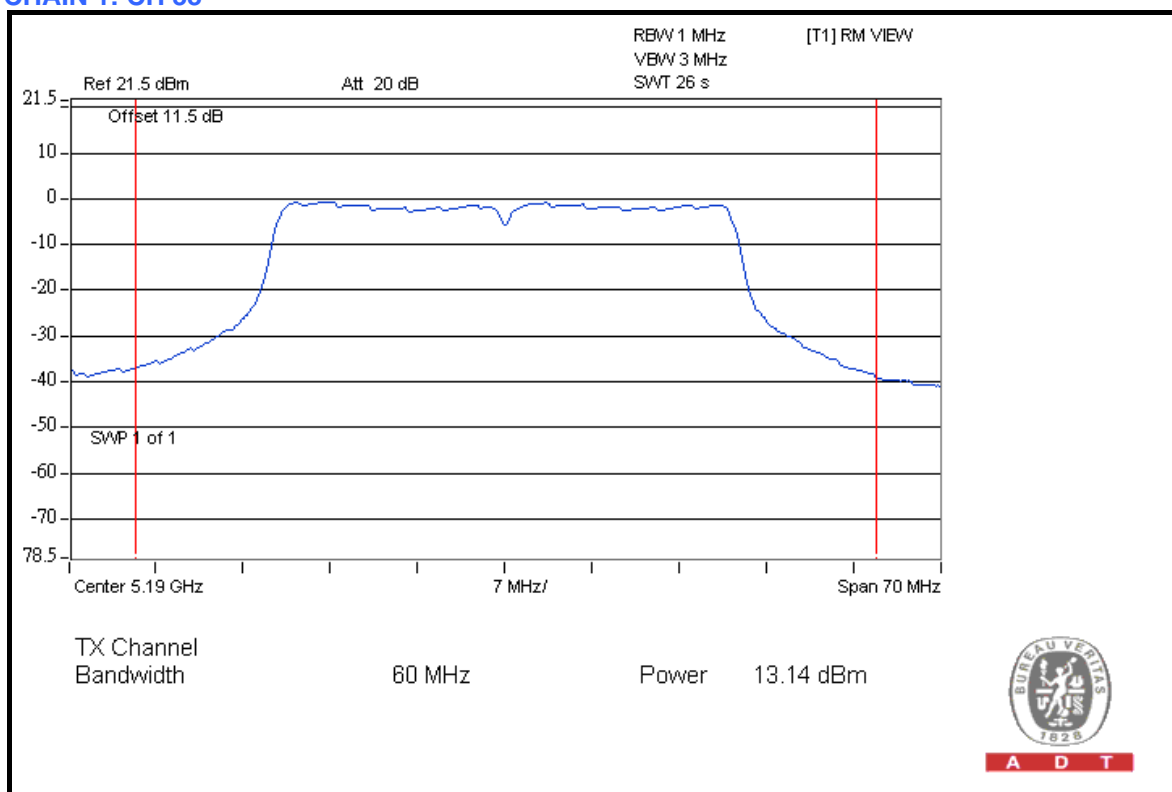

A D T



A D T

### 26dB BANDWIDTH: 802.11a

CHANNEL	CHANNEL FREQUENCY (MHz)	26dBc BANDWIDTH (MHz)		PASS / FAIL
		CHAIN 0	CHAIN 1	
36	5180	24.43	23.36	PASS
40	5200	24.41	23.66	PASS
48	5240	24.15	23.00	PASS

### CHAIN 0: CH 36

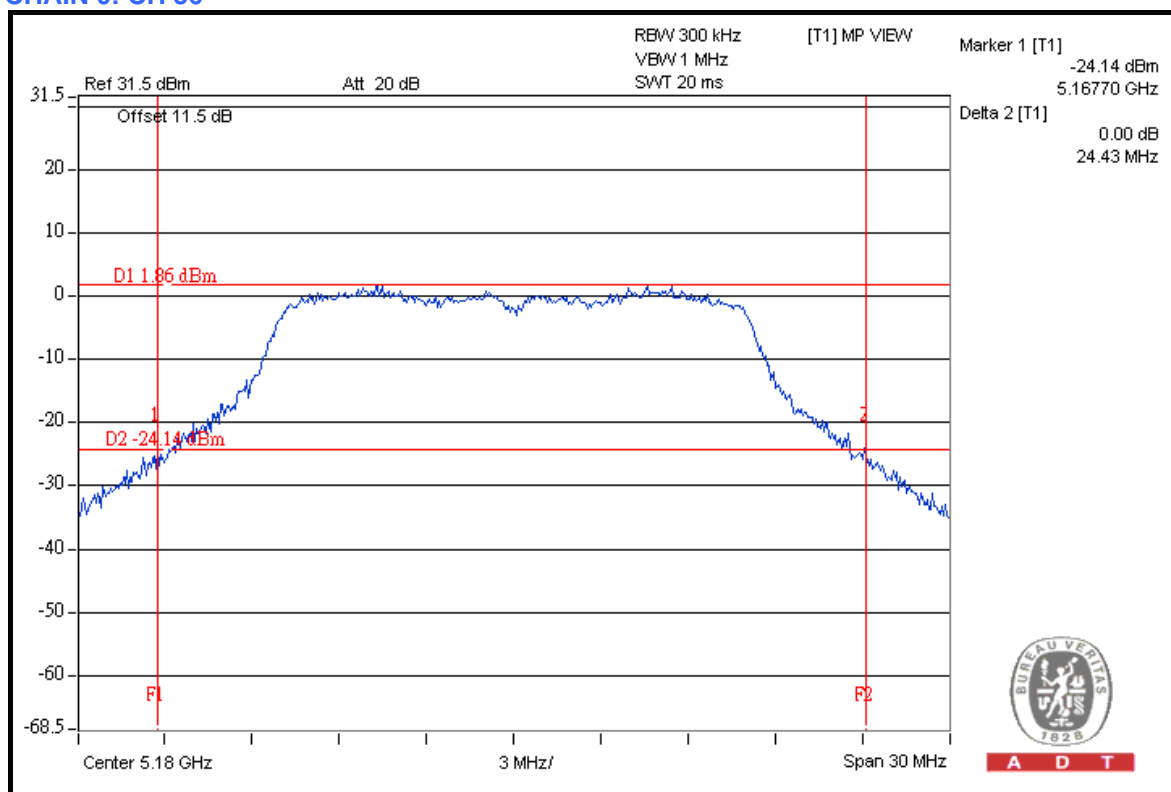

A D T



A D T

### 802.11n (20MHz)

CHANNEL	CHANNEL FREQUENCY (MHz)	26dBc BANDWIDTH (MHz)		PASS / FAIL
		CHAIN 0	CHAIN 1	
36	5180	24.59	24.54	PASS
40	5200	24.97	24.65	PASS
48	5240	25.10	23.96	PASS

### CHAIN 0: CH 48

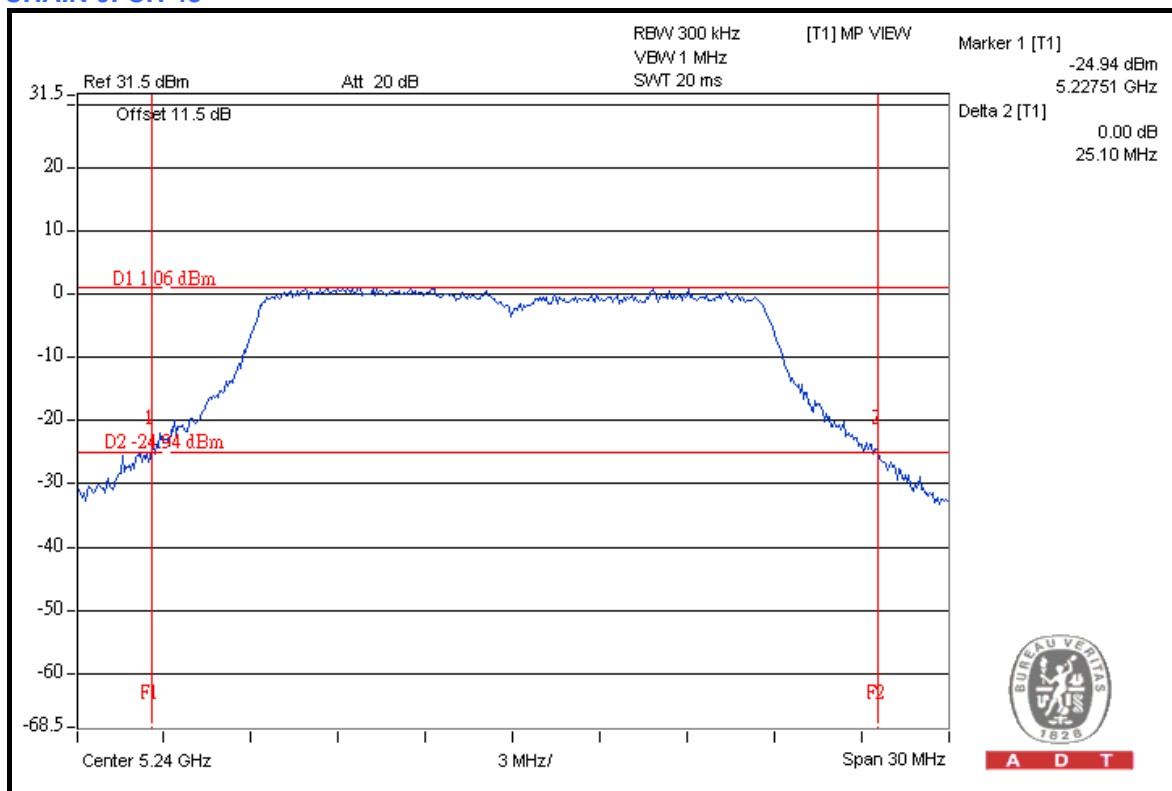

A D T





A D T

### 802.11n (40MHz)

CHANNEL	CHANNEL FREQUENCY (MHz)	26dBc BANDWIDTH (MHz)		PASS / FAIL
		CHAIN 0	CHAIN 1	
38	5190	53.66	51.61	PASS
46	5230	52.57	49.96	PASS

### CHAIN 0: CH 38

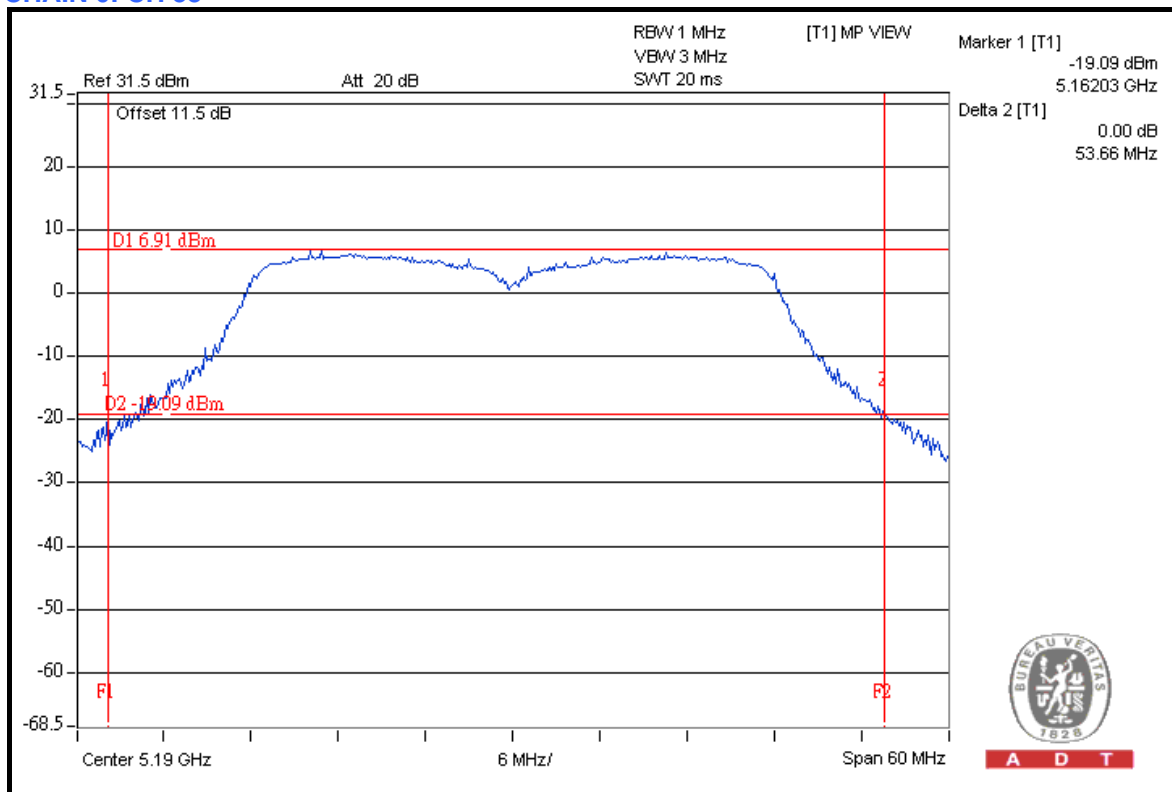

## 4.4 PEAK POWER EXCURSION MEASUREMENT

### 4.4.1 LIMITS OF PEAK POWER EXCURSION MEASUREMENT

Shall not exceed 13 dB

### 4.4.2 TEST SETUP



### 4.4.3 TEST INSTRUMENTS

Refer to section 4.1.3 to get information of above instrument.

### 4.4.4 TEST PROCEDURE

- 1) Set RBW = 1 MHz, VBW  $\leq$  3 MHz, Detector = peak.
- 2) Trace mode = max-hold. Allow the sweeps to continue until the trace stabilizes.
- 3) Use the peak search function to find the peak of the spectrum.
- 4) Measure the PPSD.
- 5) Compute the ratio of the maximum of the peak-max-hold spectrum to the PPSD.

### 4.4.5 DEVIATION FROM TEST STANDARD

No deviation.

### 4.4.6 EUT OPERATING CONDITIONS

Same as 4.2.6

#### 4.4.7 TEST RESULTS

##### 802.11a

TX chain	CHANNEL	CHANNEL FREQUENCY (MHz)	PEAK VALUE (dBm)	PPSD (dBm)	PEAK POWER EXCURSION (dB)	PEAK to AVERAGE EXCURSION LIMIT (dB)	PASS/FAIL
0	36	5180	7.40	-1.45	8.85	13	PASS
	40	5200	7.75	-1.57	9.32	13	PASS
	48	5240	7.63	-1.44	9.07	13	PASS
1	36	5180	11.52	0.94	10.58	13	PASS
	40	5200	11.18	0.46	10.72	13	PASS
	48	5240	11.35	0.79	10.56	13	PASS



A D T

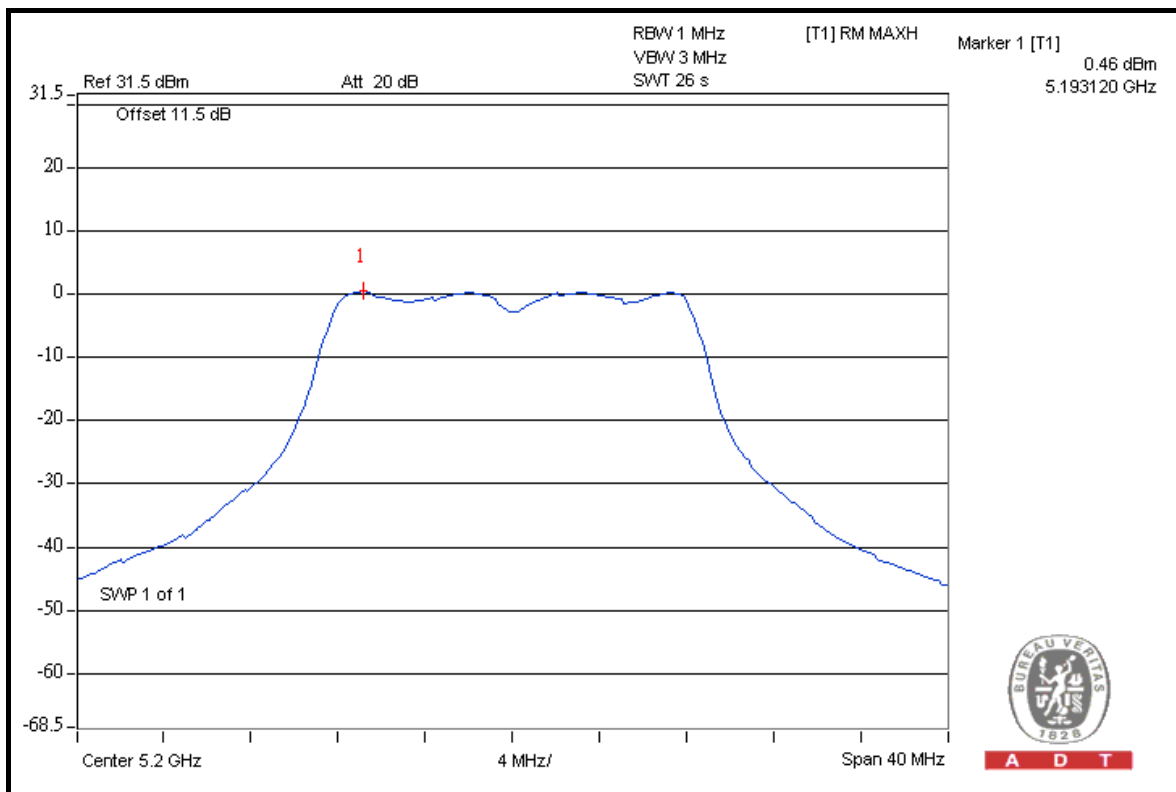
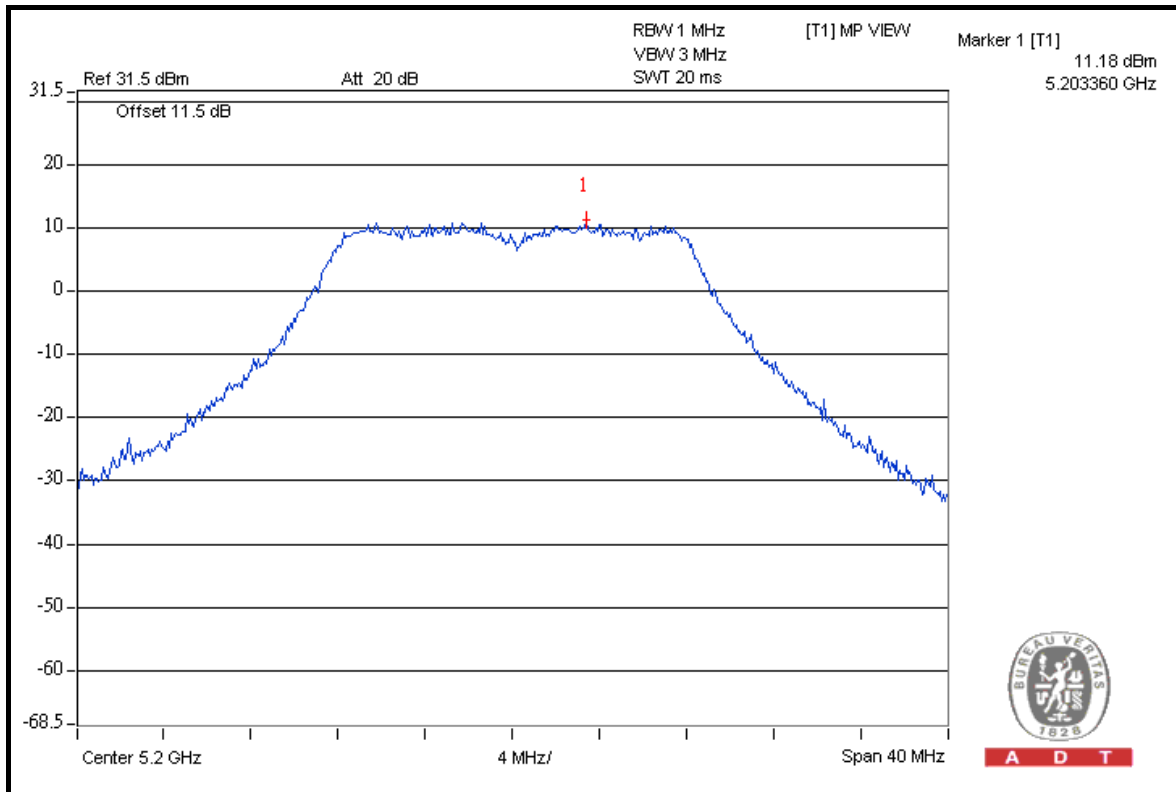



A D T

### 802.11n (20MHz)

TX chain	CHANNEL	CHANNEL FREQUENCY (MHz)	PEAK VALUE (dBm)	PPSD (dBm)	PEAK POWER EXCURSION (dB)	PEAK to AVERAGE EXCURSION LIMIT (dB)	PASS/FAIL
0	36	5180	7.03	-2.12	9.15	13	PASS
	40	5200	7.33	-1.83	9.16	13	PASS
	48	5240	7.64	-1.14	8.78	13	PASS
1	36	5180	10.47	0.71	9.76	13	PASS
	40	5200	10.50	0.20	10.30	13	PASS
	48	5240	10.64	0.73	9.91	13	PASS



A D T

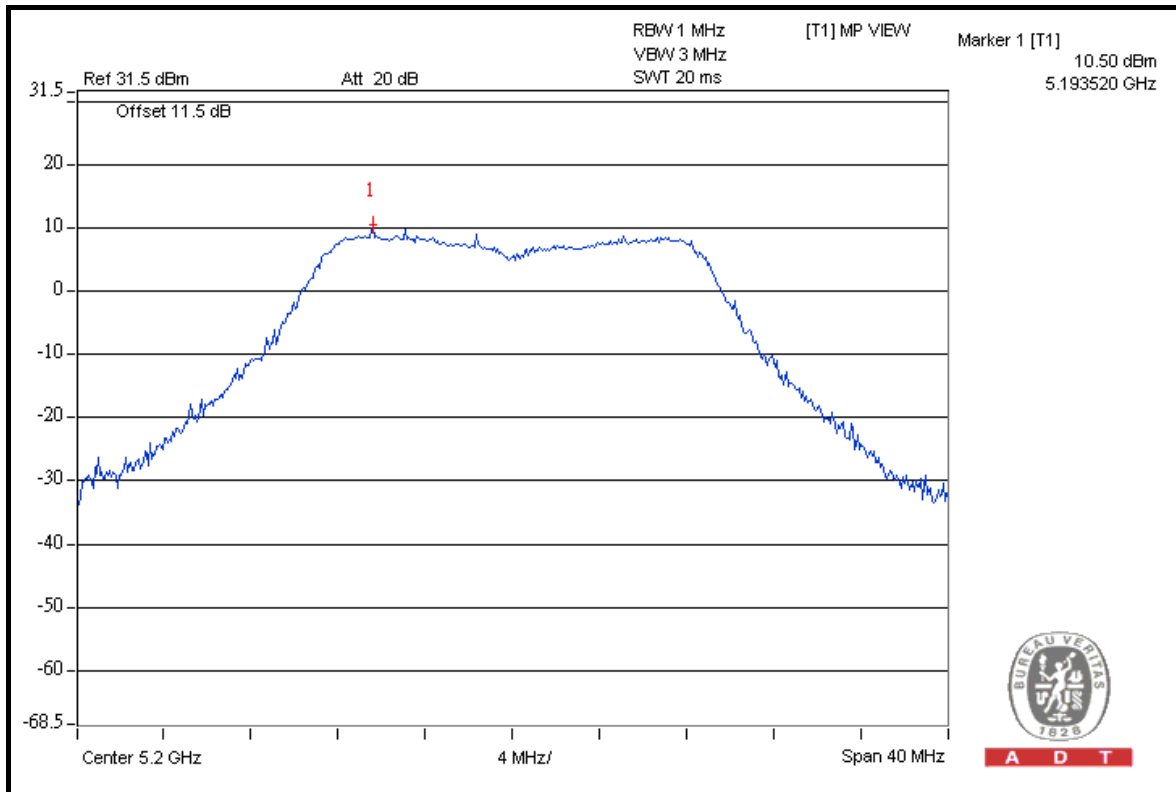

A D T

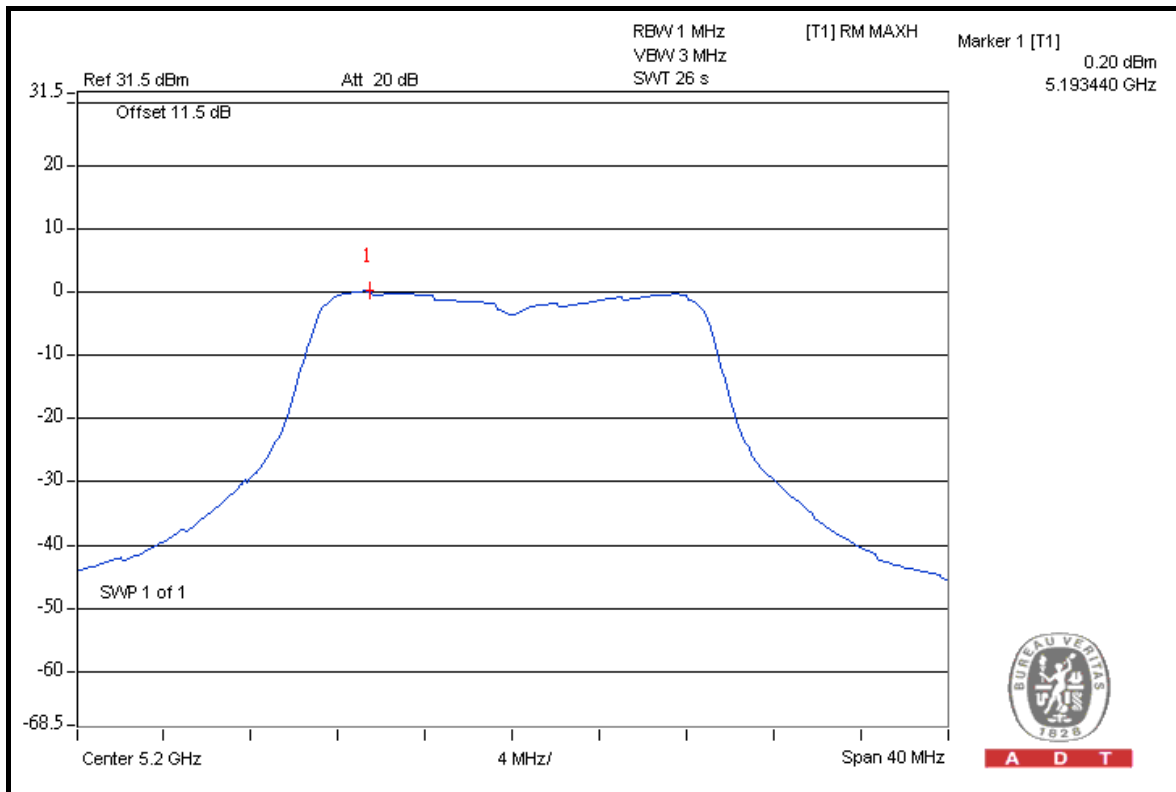

A D T



A D T

### 802.11n (40MHz)

TX chain	CHANNEL	CHANNEL FREQUENCY (MHz)	PEAK VALUE (dBm)	PPSD (dBm)	PEAK POWER EXCURSION (dB)	PEAK to AVERAGE EXCURSION LIMIT (dB)	PASS/FAIL
0	38	5190	6.82	-2.13	8.95	13	PASS
	46	5230	6.63	-2.08	8.71	13	PASS
1	38	5190	10.05	0.57	9.48	13	PASS
	46	5230	9.79	0.23	9.56	13	PASS



A D T

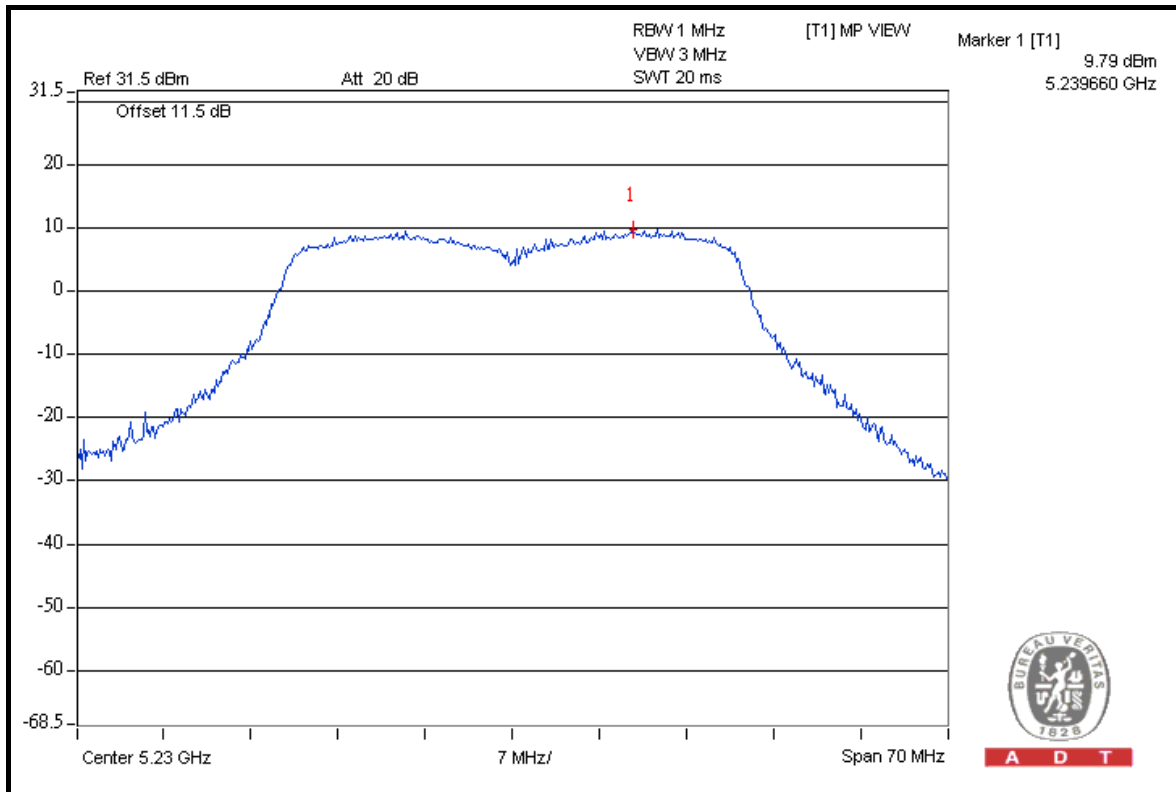

A D T

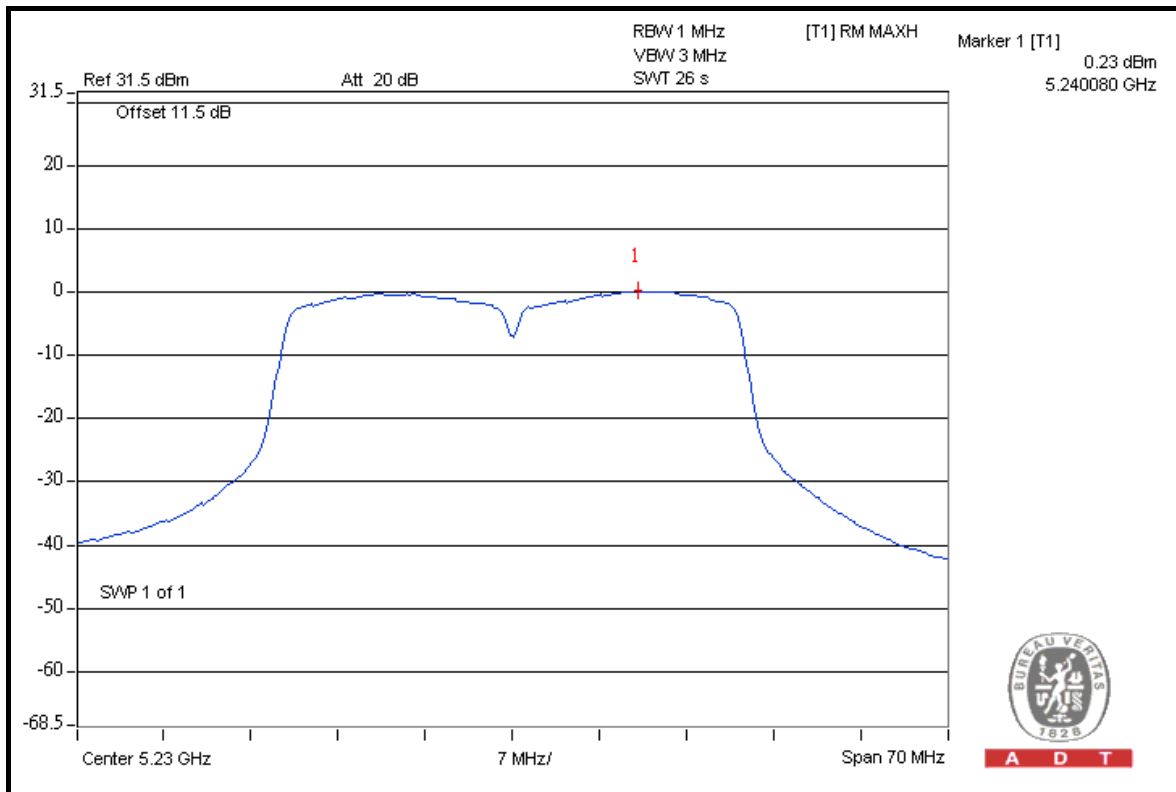

A D T



## 4.5 PEAK POWER SPECTRAL DENSITY MEASUREMENT

### 4.5.1 LIMITS OF PEAK POWER SPECTRAL DENSITY MEASUREMENT

FREQUENCY BAND	LIMIT(dBm)
5.15 ~ 5.25GHz	4
5.25 ~ 5.35GHz and 5.470 ~ 5.725GHz	11
5.725~5825GHz	17

### 4.5.2 TEST SETUP

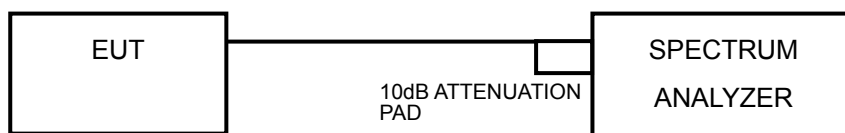

### 4.5.3 TEST INSTRUMENTS

Refer to section 4.1.3 to get information of above instrument.

### 4.5.4 TEST PROCEDURES

1. Set RBW = 1 MHz, VBW = 3 MHz.
2. Set sweep time =26 S.
3. Set detector = RMS.
4. Perform a single sweep.

### 4.5.5 DEVIATION FROM TEST STANDARD

No deviation.

### 4.5.6 EUT OPERATING CONDITIONS

Same as 4.3.6.

## 4.5.7 TEST RESULTS

### 802.11a

CHAN.	CHAN. FREQ. (MHz)	RF POWER LEVEL IN 1kHz BW (dBm)		TOTAL POWER DENSITY (dBm)	MAX. LIMIT (dBm)	PASS / FAIL
		CHAIN 0	CHAIN 1			
36	5180	-1.45	0.94	2.9	3	PASS
40	5200	-1.57	0.46	2.6	3	PASS
48	5240	-1.44	0.79	2.8	3	PASS

**NOTE:** 1. Directional gain =  $4\text{dBi} + 10\log(2) = 7\text{dBi} > 6\text{dBi}$ , so the limit shall be reduced to  $4 - (7 - 6) = 3\text{dBm}$ .

**NOTE:** 2. Method 1 of power density measurement of KDB 662911 is using for calculating total power density. Total power density is summing entire spectra across corresponding frequency bins on the various outputs by computer

### 802.11n (20MHz)

CHAN.	CHAN. FREQ. (MHz)	RF POWER LEVEL IN 1kHz BW (dBm)		TOTAL POWER DENSITY (dBm)	MAX. LIMIT (dBm)	PASS / FAIL
		CHAIN 0	CHAIN 1			
36	5180	-2.12	0.71	2.5	4	PASS
40	5200	-1.83	0.20	2.3	4	PASS
48	5240	-1.14	0.73	2.9	4	PASS

**NOTE:** Method 1 of power density measurement of KDB 662911 is using for calculating total power density. Total power density is summing entire spectra across corresponding frequency bins on the various outputs by computer

### 802.11n (40MHz)

CHAN.	CHAN. FREQ. (MHz)	RF POWER LEVEL IN 1kHz BW (dBm)		TOTAL POWER DENSITY (dBm)	MAX. LIMIT (dBm)	PASS / FAIL
		CHAIN 0	CHAIN 1			
38	5190	-2.13	0.57	2.4	4	PASS
46	5230	-2.08	0.23	2.2	4	PASS

**NOTE:** Method 1 of power density measurement of KDB 662911 is using for calculating total power density. Total power density is summing entire spectra across corresponding frequency bins on the various outputs by computer

## 4.6 FREQUENCY STABILITY

### 4.6.1 LIMITS OF FREQUENCY STABILITY MEASUREMENT

The frequency of the carrier signal shall be maintained within band of operation

### 4.6.2 TEST SETUP

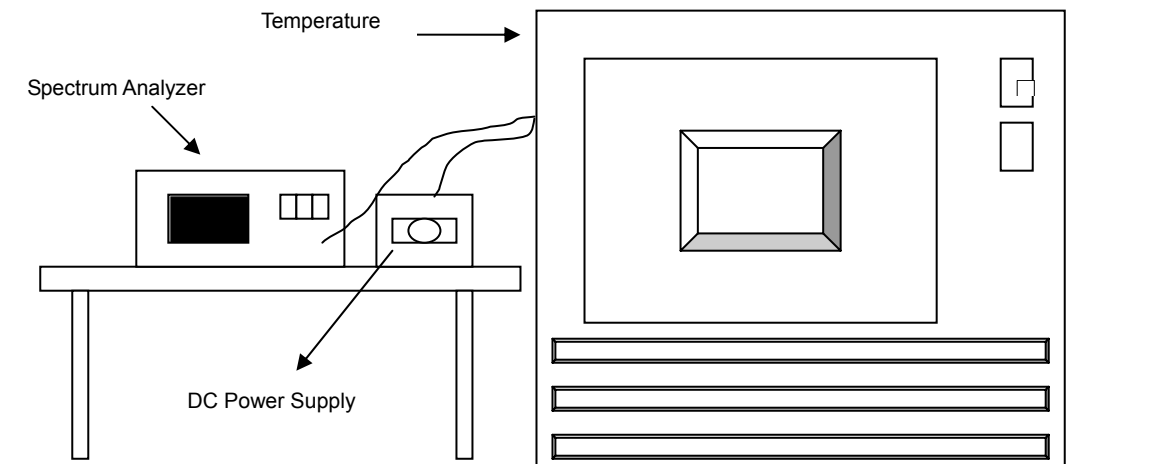

### 4.6.3 TEST INSTRUMENTS

Refer to section 4.1.3 to get information of above instrument.

#### 4.6.4 TEST PROCEDURE

- a. The EUT was placed inside the environmental test chamber and powered by nominal DC voltage.
- b. Turn the EUT on and couple its output to a spectrum analyzer.
- c. Turn the EUT off and set the chamber to the highest temperature specified.
- d. Allow sufficient time (approximately 30 min) for the temperature of the chamber to stabilize, turn the EUT on and measure the operating frequency after 2, 5, and 10 minutes.
- e. Repeat step 2 and 3 with the temperature chamber set to the lowest temperature.
- f. The test chamber was allowed to stabilize at +20 degree C for a minimum of 30 minutes. The supply voltage was then adjusted on the EUT from 85% to 115% and the frequency record.

#### 4.6.5 DEVIATION FROM TEST STANDARD

No deviation.

#### 4.6.6 EUT OPERATING CONDITION

Set the EUT transmit at un-modulation mode to test frequency stability.

#### 4.6.7 TEST RESULTS

FREQUENCY STABILITY VERSUS TEMP.									
OPERATING FREQUENCY: 5200MHz									
TEMP. (°C)	POWER SUPPLY (Vac)	0 MINUTE		2 MINUTE		5 MINUTE		10 MINUTE	
		Measured Frequency	Frequency Drift	Measured Frequency	Frequency Drift	Measured Frequency	Frequency Drift	Measured Frequency	Frequency Drift
		(MHz)	ppm	(MHz)	ppm	(MHz)	ppm	(MHz)	ppm
55	110.0	5199.987883	-2.330	5199.988088	-2.291	5199.988169	-2.275	5199.988274	-2.255
50	110.0	5199.988539	-2.204	5199.988714	-2.170	5199.988613	-2.190	5199.988443	-2.222
40	110.0	5199.989720	-1.977	5199.989914	-1.940	5199.989626	-1.995	5199.989569	-2.006
30	110.0	5199.991185	-1.695	5199.991427	-1.649	5199.991271	-1.679	5199.991586	-1.618
20	110.0	5199.992898	-1.366	5199.993325	-1.284	5199.993401	-1.269	5199.993491	-1.252
10	110.0	5199.991840	-1.569	5199.992184	-1.503	5199.991887	-1.560	5199.992349	-1.471
0	110.0	5199.989750	-1.971	5199.989772	-1.967	5199.989864	-1.949	5199.989823	-1.957
-10	110.0	5199.989411	-2.036	5199.989683	-1.984	5199.989412	-2.036	5199.989299	-2.058
-20	110.0	5199.988660	-2.181	5199.988821	-2.150	5199.988424	-2.226	5199.988905	-2.134
-30	110.0	5199.988548	-2.202	5199.988914	-2.132	5199.988785	-2.157	5199.988339	-2.242

FREQUENCY STABILITY VERSUS VOLTAGE									
OPERATING FREQUENCY: 5200MHz									
TEMP. (°C)	POWER SUPPLY (Vac)	0 MINUTE		2 MINUTE		5 MINUTE		10 MINUTE	
		Measured Frequency	Frequency Drift	Measured Frequency	Frequency Drift	Measured Frequency	Frequency Drift	Measured Frequency	Frequency Drift
		(MHz)	ppm	(MHz)	ppm	(MHz)	ppm	(MHz)	ppm
20	93.5	5199.991303	-1.672	5199.991226	-1.687	5199.991473	-1.640	5199.990924	-1.745
	110.0	5199.992898	-1.366	5199.993325	-1.284	5199.993401	-1.269	5199.993491	-1.252
	126.5	5199.992363	-1.469	5199.991966	-1.545	5199.991920	-1.554	5199.991807	-1.576

## 5. PHOTOGRAPHS OF THE TEST CONFIGURATION

Please refer to the attached file (Test Setup Photo).



## 6. INFORMATION ON THE TESTING LABORATORIES

We, Bureau Veritas Consumer Products Services (H.K.) Ltd., Taoyuan Branch, were founded in 1988 to provide our best service in EMC, Radio, Telecom and Safety consultation. Our laboratories are accredited and approved according to ISO/IEC 17025.

Copies of accreditation and authorization certificates of our laboratories obtained from approval agencies can be downloaded from our web site: [www.adt.com.tw/index.5.phtml](http://www.adt.com.tw/index.5.phtml). If you have any comments, please feel free to contact us at the following:

**Linko EMC/RF Lab:**

Tel: 886-2-26052180

Fax: 886-2-26051924

**Hsin Chu EMC/RF Lab:**

Tel: 886-3-5935343

Fax: 886-3-5935342

**Hwa Ya EMC/RF/Safety Telecom Lab:**

Tel: 886-3-3183232

Fax: 886-3-3185050

**Email:** [service.adt@tw.bureauveritas.com](mailto:service.adt@tw.bureauveritas.com)

**Web Site:** [www.adt.com.tw](http://www.adt.com.tw)

The address and road map of all our labs can be found in our web site also.

## **7. APPENDIX A - MODIFICATIONS RECORDERS FOR ENGINEERING CHANGES TO THE EUT BY THE LAB**

No any modifications are made to the EUT by the lab during the test.

**---END---**