



RADIO TEST REPORT

Test Report No. : 11163939H-A

Applicant : DENSO CORPORATION
Type of Equipment : Smart Phone Gateway
Model No. : S1NF0
FCC ID : HYQS1NF0
Test regulation : FCC Part 15 Subpart C: 2016
Test Result : Complied

1. This test report shall not be reproduced in full or partial, without the written approval of UL Japan, Inc.
2. The results in this report apply only to the sample tested.
3. This sample tested is in compliance with the above regulation.
4. The test results in this report are traceable to the national or international standards.
5. This test report must not be used by the customer to claim product certification, approval, or endorsement by NVLAP, NIST, or any agency of the Federal Government.
6. This test report covers Radio technical requirements. It does not cover administrative issues such as Manual or non-Radio test related Requirements. (if applicable)

Date of test: April 15 to 20, 2016

Representative test engineer:

Koji Yamamoto

Koji Yamamoto
Engineer
Consumer Technology Division

Approved by:

M. Imura

Motoya Imura
Engineer
Consumer Technology Division



NVLAP LAB CODE: 200572-0

This laboratory is accredited by the NVLAP LAB CODE 200572-0, U.S.A. The tests reported herein have been performed in accordance with its terms of accreditation. *As for the range of Accreditation in NVLAP, you may refer to the WEB address, http://japan.ul.com/resources/emc_accredited/

UL Japan, Inc.

Ise EMC Lab.

4383-326 Asama-cho, Ise-shi, Mie-ken 516-0021 JAPAN

Telephone : +81 596 24 8999

Facsimile : +81 596 24 8124

13-EM-F0429

CONTENTS	PAGE
SECTION 1: Customer information.....	4
SECTION 2: Equipment under test (E.U.T.).....	4
SECTION 3: Test specification, procedures & results.....	5
SECTION 4: Operation of E.U.T. during testing.....	8
SECTION 5: Radiated Spurious Emission	10
SECTION 6: Antenna Terminal Conducted Tests.....	13
APPENDIX 1: Test data	14
6dB Bandwidth	14
Maximum Peak Output Power	16
Average Output Power	17
Radiated Spurious Emission	19
Power Density	25
99% Occupied Bandwidth	27
APPENDIX 2: Test instruments	28
APPENDIX 3: Photographs of test setup	30
Radiated Spurious Emission	30
Worst Case Position (Horizontal: X-axis/ Vertical:Z-axis)	32

SECTION 1: Customer information

Company Name : DENSO CORPORATION
Address : 1-1 Showa-cho, Kariya-shi, Aichi-ken, 448-8661 Japan
Telephone Number : +81-566-61-5324
Facsimile Number : +81-566-25-4834
Contact Person : Akihiro Taguchi

SECTION 2: Equipment under test (E.U.T.)

2.1 Identification of E.U.T.

Type of Equipment : Smart Phone Gateway
Model No. : S1NF0
Serial No. : Refer to Section 4, Clause 4.2
Rating : DC 12.0 V
Receipt Date of Sample : April 15, 2016
Country of Mass-production : United States of America
Condition of EUT : Production prototype
(Not for Sale: This sample is equivalent to mass-produced items.)
Modification of EUT : No Modification by the test lab

2.2 Product Description

Model: S1NF0 (referred to as the EUT in this report) is a Smart Phone Gateway.

General Specification

Clock frequency(ies) in the system : 32 MHz (BLE IC) / 32.768 kHz (BLE IC) / 4 MHz (MCU)

Radio Specification

Radio Type : Transceiver
Frequency of Operation : 2402 MHz to 2480 MHz
Modulation : FHSS, GFSK
Operating voltage (inner) : DC 3.3 V
Antenna type : Inverted F Antenna
Antenna Gain : +3.3 dBi (max)
Number of channel : 39
Channel spacing : 2 MHz

SECTION 3: Test specification, procedures & results

3.1 Test Specification

Test Specification : FCC Part 15 Subpart C
FCC part 15 final revised on April 6, 2016.

Title : FCC 47CFR Part15 Radio Frequency Device Subpart C Intentional Radiators
Section 15.207 Conducted limits
Section 15.247 Operation within the bands 902-928MHz,
2400-2483.5MHz, and 5725-5850MHz

3.2 Procedures and results

Item	Test Procedure	Specification	Worst margin	Results	Remarks
Conducted Emission	FCC: ANSI C63.10-2013 6. Standard test methods ----- IC: RSS-Gen 8.8	FCC: Section 15.207 ----- IC: RSS-Gen 8.8	N/A	N/A *1)	-
6dB Bandwidth	FCC: KDB 558074 D01 DTS Meas Guidance v03r05 ----- IC: -	FCC: Section 15.247(a)(2) ----- IC: RSS-247 5.2(1)	See data.	Complied	Conducted
Maximum Peak Output Power	FCC: KDB 558074 D01 DTS Meas Guidance v03r05 ----- IC: RSS-Gen 6.12	FCC: Section 15.247(b)(3) ----- IC: RSS-247 5.4(4)		Complied	Conducted
Power Density	FCC: KDB 558074 D01 DTS Meas Guidance v03r05 ----- IC: -	FCC: Section 15.247(e) ----- IC: RSS-247 5.2(2)		Complied	Conducted
Spurious Emission Restricted Band Edges	FCC: KDB 558074 D01 DTS Meas Guidance v03r05 ----- IC: RSS-Gen 6.13	FCC: Section15.247(d) ----- IC: RSS-247 5.5 RSS-Gen 8.9 RSS-Gen 8.10	3.9 dB 2483.500 MHz, AV, Horizontal	Complied	Radiated (above 30 MHz) *2)

Note: UL Japan, Inc.'s EMI Work Procedures No. 13-EM-W0420 and 13-EM-W0422.

*1) The test is not applicable since the EUT is not the device that is designed to be connected to the public utility (AC) power line.

*2) Radiated test was selected over 30 MHz based on section 15.247(d) and KDB 558074 D01 DTS Meas Guidance v03r05 12.2.7.

* In case any questions arise about test procedure, ANSI C63.10: 2013 is also referred.

FCC Part 15.31 (e)

This EUT provides stable voltage (DC 3.3 V) constantly to RF Module regardless of input voltage. Therefore, this EUT complies with the requirement.

FCC Part 15.203 Antenna requirement

It is impossible for end users to replace the antenna, because the antenna is mounted inside of the EUT. Therefore, the equipment complies with the antenna requirement of Section 15.203.

UL Japan, Inc.

Ise EMC Lab.

4383-326 Asama-cho, Ise-shi, Mie-ken 516-0021 JAPAN

Telephone : +81 596 24 8999

Facsimile : +81 596 24 8124

3.3 Addition to standard

Item	Test Procedure	Specification	Worst margin	Results	Remarks
99% Occupied Bandwidth	IC: RSS-Gen 6.6	IC: -	N/A	-	Conducted

Other than above, no addition, exclusion nor deviation has been made from the standard.

3.4 Uncertainty

EMI

The following uncertainties have been calculated to provide a confidence level of 95 % using a coverage factor $k = 2$.
Ise EMC Lab.

Antenna terminal test Uncertainty (+/-)							
Power meter		Conducted emission and Power density			Conducted emission		Channel power
Below 1 GHz	Above 1 GHz	Below 1 GHz	1 GHz - 3 GHz	3 GHz - 18 GHz	18 GHz - 26.5 GHz	26.5 GHz - 40 GHz	
0.9 dB	1.0 dB	1.4 dB	1.7 dB	2.8 dB	2.8 dB	2.9 dB	

Test distance	Radiated emission (+dB) 9 kHz - 30 MHz
3m	3.8 dB
10m	3.7 dB

Polarity	Radiated emission (Below 1GHz)			
	(3 m*)(+dB)		(10 m*)(+dB)	
	30 - 200 MHz	200 - 1000MHz	30 - 200 MHz	200 - 1000MHz
Horizontal	4.9 dB	5.2 dB	4.9 dB	5.0 dB
Vertical	4.6 dB	5.9 dB	5.0 dB	5.0 dB

Radiated emission				
(3 m*)(+dB)		(1 m*)(+dB)	(0.5 m*)(+dB)	(10 m*)(+dB)
1 - 6GHz	6 - 18GHz	10 - 26.5 GHz	26.5 - 40GHz	1 - 18 GHz
5.1 dB	5.3 dB	5.1 dB	5.1 dB	5.3 dB

*Measurement distance

Radiated emission test

The data listed in this report meets the limits unless the uncertainty is taken into consideration.

3.5 Test Location

UL Japan, Inc. Ise EMC Lab. *NVLAP Lab. code: 200572-0
4383-326 Asama-cho, Ise-shi, Mie-ken 516-0021 JAPAN
Telephone: +81 596 24 8999, Facsimile: +81 596 24 8124

Test site	IC Registration Number	Width x Depth x Height (m)	Size of reference ground plane (m) / horizontal conducting plane	Other rooms	Maximum measurement distance
No.1 semi-anechoic chamber	2973C-1	19.2 x 11.2 x 7.7	7.0 x 6.0	No.1 Power source room	10 m
No.2 semi-anechoic chamber	2973C-2	7.5 x 5.8 x 5.2	4.0 x 4.0	-	3 m
No.3 semi-anechoic chamber	2973C-3	12.0 x 8.5 x 5.9	6.8 x 5.75	No.3 Preparation room	3 m
No.3 shielded room	-	4.0 x 6.0 x 2.7	N/A	-	-
No.4 semi-anechoic chamber	2973C-4	12.0 x 8.5 x 5.9	6.8 x 5.75	No.4 Preparation room	3 m
No.4 shielded room	-	4.0 x 6.0 x 2.7	N/A	-	-
No.5 semi-anechoic chamber	-	6.0 x 6.0 x 3.9	6.0 x 6.0	-	-
No.6 shielded room	-	4.0 x 4.5 x 2.7	4.0 x 4.5	-	-
No.6 measurement room	-	4.75 x 5.4 x 3.0	4.75 x 4.15	-	-
No.7 shielded room	-	4.7 x 7.5 x 2.7	4.7 x 7.5	-	-
No.8 measurement room	-	3.1 x 5.0 x 2.7	N/A	-	-
No.9 measurement room	-	8.8 x 4.6 x 2.8	2.4 x 2.4	-	-
No.11 measurement room	-	6.2 x 4.7 x 3.0	4.8 x 4.6	-	-

3.6 Test data, Test instruments, and Test set up

Refer to APPENDIX.

SECTION 4: Operation of E.U.T. during testing

4.1 Operating Mode(s)

Mode	Tested Frequency
Transmitting mode (Tx mode)	2402 MHz 2440 MHz 2480 MHz
*Power of the EUT was set by the software as follows; Power settings: 0dBm Software: Smart RF Studio7 (Version: 2.3.1) *This setting of software is the worst case. Any conditions under the normal use do not exceed the condition of setting. In addition, end users cannot change the settings of the output power of the product.	

4.2 Configuration and peripherals

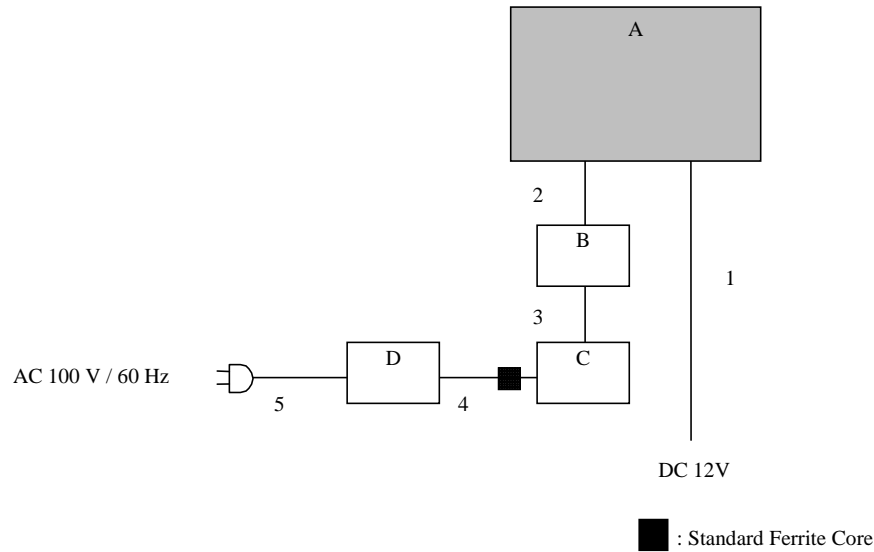

* Cabling and setup(s) were taken into consideration and test data was taken under worse case conditions.

Description of EUT

No.	Item	Model number	Serial number	Manufacturer	Remarks
A	Smart Phone Gateway	S1NF0	KF *1) D1 *2)	DENSO CORPORATION	EUT
B	CC Debugger	None (only ordering code used by TI is CC-DEBUGGER v1.0.0)	45692168	TEXAS INSTRUMENTS	*3)
C	Laptop PC	CF-N8HWC DPS	0CKSA09265	Panasonic	*3)
D	AC Adapter	CF-AA6372B	6372BM610X10953E	Psnasonic	*3)

*1) Used for Conducted Emission and Radiated Emission tests only

*2) Used for Antenna Terminal conducted test

*3) Used for Conducted Emission and Radiated Emission tests (above 1GHz) only.

List of cables used

No.	Name	Length (m)	Shield		Remarks
			Cable	Connector	
1	DC Cable	2.30 *1) 1.00 *2)	Unshielded	Unshielded	-
2	Signal Cable	0.12	Unshielded	Unshielded	*3)
3	USB Cable	1.50	Shielded	Shielded	*3)
4	DC Cable	1.10	Unshielded	Unshielded	*3)
5	AC Cable	0.90	Unshielded	Unshielded	*3)

*1) Used for Conducted Emission and Radiated Emission tests only

*2) Used for Antenna Terminal conducted test

*3) Used for Conducted Emission and Radiated Emission tests (above 1GHz) only.

UL Japan, Inc.

Ise EMC Lab.

4383-326 Asama-cho, Ise-shi, Mie-ken 516-0021 JAPAN

Telephone : +81 596 24 8999

Facsimile : +81 596 24 8124

SECTION 5: Radiated Spurious Emission

Test Procedure

It was measured based on "11.0 Emissions in non-restricted frequency bands" of "558074 D01 DTS Meas Guidance v03r05".

[For below 1 GHz]

EUT was placed on a urethane platform of nominal size, 0.5 m by 1.0 m, raised 0.8 m above the conducting ground plane. The Radiated Electric Field Strength has been measured in a Semi Anechoic Chamber with a ground plane.

[For above 1 GHz]

EUT was placed on a urethane platform of nominal size, 0.5 m by 0.5 m, raised 1.5 m above the conducting ground plane.

The Radiated Electric Field Strength has been measured in a Semi Anechoic Chamber with absorbent materials lined on a ground plane.

The height of the measuring antenna varied between 1 and 4 m and EUT was rotated a full revolution in order to obtain the maximum value of the electric field strength.

The measurements were performed for both vertical and horizontal antenna polarization with the Test Receiver, or the Spectrum Analyzer.

The measurements were made with the following detector function of the test receiver and the Spectrum analyzer (in linear mode).

The test was made with the detector (RBW/VBW) in the following table.

When using Spectrum analyzer, the test was made with adjusting span to zero by using peak hold.

Test Antennas are used as below;

Frequency	Below 30 MHz	30 MHz to 200 MHz	200 MHz to 1 GHz	Above 1 GHz
Antenna Type	Loop	Biconical	Logperiodic	Horn

Frequency: From 9 kHz to 30 MHz at distance 3 m

The EUT was rotated a full revolution in order to obtain the maximum value of the electric field strength.

The measurements were performed for vertical polarization (antenna angle: 0 deg.).

*Refer to Figure 1 about Direction of the Loop Antenna.

These tests were performed in semi anechoic chamber. Therefore the measured level of emissions may be higher than if measurements were made without a ground plane. However test results were confirmed to pass against standard limit.

Side View (Vertical)

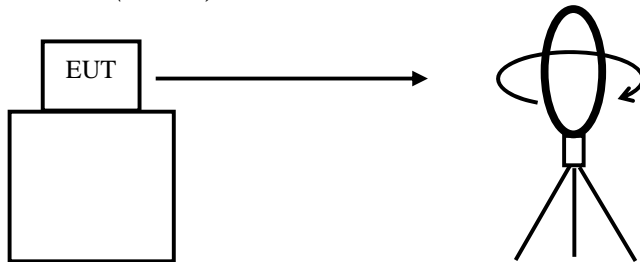

Top View (Vertical)

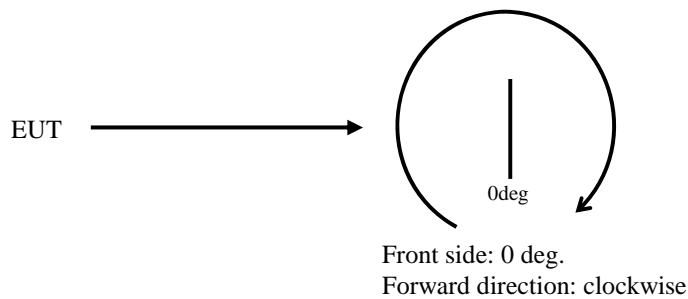

In any 100 kHz bandwidth outside the restricted band in which the spread spectrum intentional radiator is operating, the radio frequency power that is produced by the intentional radiator confirmed 20 dB below that in the 100 kHz bandwidth within the band that contains the highest level of the desired power, based on a radiated measurement.

20 dBc was applied to the frequency over the limit of FCC 15.209 / Table 4 of RSS-Gen 8.9(IC) and outside the restricted band of FCC15.205 / Table 6 of RSS-Gen 8.10 (IC).

Frequency	From 9 kHz to 90 kHz and From 110 kHz to 150 kHz	From 90 kHz to 110 kHz	From 150 kHz to 490 kHz	From 490 kHz to 30 MHz	From 30 MHz to 1 GHz
Instrument used	Test Receiver				
Detector	PK / AV	QP	PK / AV	QP	QP
IF Bandwidth	BW 200 Hz	BW 200 Hz	BW 9 kHz	BW 9 kHz	BW 120 kHz
Test Distance	3 m *1)	3 m *1)	3 m *1)	3 m *2)	3 m

Frequency	Above 1 GHz		20 dBc
Instrument used	Spectrum Analyzer		Spectrum Analyzer
Detector	PK	AV *5)	PK
IF Bandwidth	RBW: 1 MHz VBW: 3 MHz	Average Power Method: <u>12.2.5.1</u> RBW: 1 MHz VBW: 3 MHz Detector: Power Averaging (RMS) Trace: 100 traces	RBW: 100 kHz VBW: 300kHz
Test Distance	3 m (below 1 GHz), 3 m *3) (1 GHz – 10 GHz), 1 m *4) (10 GHz – 26.5 GHz)		3 m (below 1 GHz), 3 m *3) (1 GHz – 10 GHz), 1 m *4) (10 GHz – 26.5 GHz)

*1) Distance Factor: $40 \times \log(3 \text{ m} / 300 \text{ m}) = -80 \text{ dB}$

*2) Distance Factor: $40 \times \log(3 \text{ m} / 30 \text{ m}) = -40 \text{ dB}$

*3) Distance Factor: $20 \times \log(4.5 \text{ m} / 3.0 \text{ m}) = 3.5 \text{ dB}$

*4) Distance Factor: $20 \times \log(1.0 \text{ m} / 3.0 \text{ m}) = -9.5 \text{ dB}$

*5) Average Power Measurement was performed based on 6.0 & 12.2.5 of "KDB 558074 D01 DTS Meas Guidance v03r05"

- The carrier level and noise levels were confirmed at each position of X, Y and Z axes of EUT to see the position of maximum noise, and the test was made at the position that has the maximum noise.

The test results and limit are rounded off to one decimal place, so some differences might be observed.

Measurement range : 9 kHz - 26.5 GHz
Test data : APPENDIX
Test result : Pass

UL Japan, Inc.

Ise EMC Lab.

4383-326 Asama-cho, Ise-shi, Mie-ken 516-0021 JAPAN

Telephone : +81 596 24 8999

Facsimile : +81 596 24 8124

SECTION 6: Antenna Terminal Conducted Tests

Test Procedure

The tests were made with below setting connected to the antenna port.

Test	Span	RBW	VBW	Sweep time	Detector	Trace	Instrument used
6dB Bandwidth	10 MHz	100 kHz	300 kHz	Auto	Peak	Max Hold	Spectrum Analyzer
99% Occupied Bandwidth *1)	Enough width to display emission skirts	1 to 5 % of OBW	Three times of RBW	Auto	Peak	Max Hold	Spectrum Analyzer
Maximum Peak Output Power	-	-	-	Auto	Peak/ Average *2)	-	Power Meter (Sensor: 50 MHz BW)
Peak Power Density	1.5 times the 6dB Bandwidth	3 kHz	9.1 kHz	Auto	Peak	Max Hold	Spectrum Analyzer *3)

*1) Peak hold was applied as Worst-case measurement.

*2) Reference data

*3) Section 10.2 Method PKPSD (peak PSD) of "KDB 558074 D01 DTS Meas Guidance v03r05".

The test results and limit are rounded off to two decimals place, so some differences might be observed.

Test data : APPENDIX

Test result : Pass

APPENDIX 1: Test data

6dB Bandwidth

Test place Ise EMC Lab. No.3 Measurement Room
Report No. 11163939H
Date April 20, 2016
Temperature / Humidity 23 deg. C / 45 % RH
Engineer Koji Yamamoto
Mode Tx BT LE

Frequency [MHz]	6dB Bandwidth [MHz]	Limit [kHz]
2402	0.730	> 500
2440	0.720	> 500
2480	0.741	> 500

6dB Bandwidth

BT LE

2402 MHz

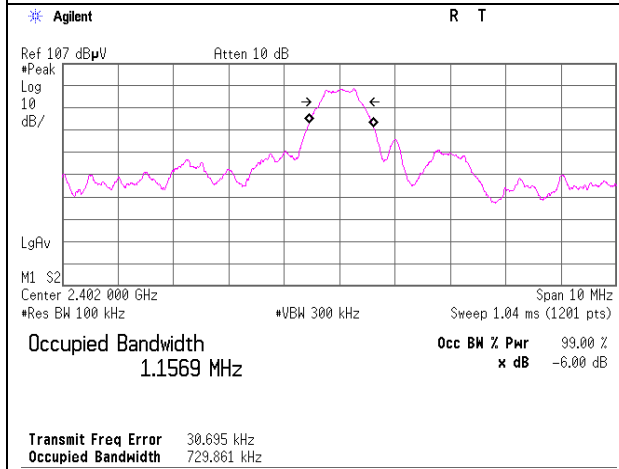

2440 MHz

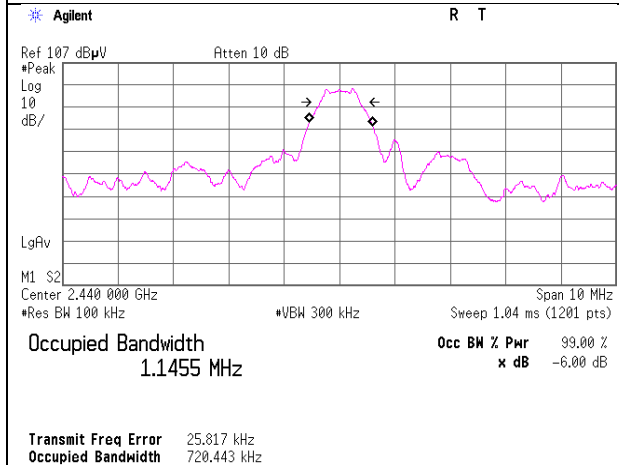

2480 MHz

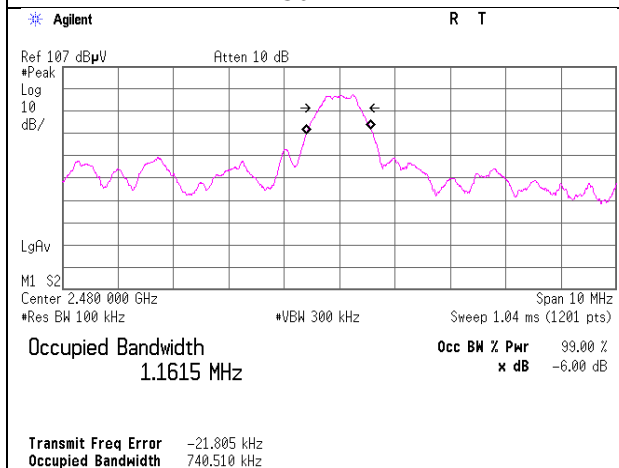

UL Japan, Inc.

Ise EMC Lab.

4383-326 Asama-cho, Ise-shi, Mie-ken 516-0021 JAPAN

Telephone : +81 596 24 8999

Facsimile : +81 596 24 8124

Maximum Peak Output Power

Test place Ise EMC Lab. No.3 Measurement Room
Report No. 11163939H
Date April 20, 2016
Temperature / Humidity 23 deg. C / 45 % RH
Engineer Koji Yamamoto
Mode Tx BT LE

Freq. [MHz]	Reading [dBm]	Cable Loss [dB]	Atten. Loss [dB]	Result		Limit		Margin [dB]
				[dBm]	[mW]	[dBm]	[mW]	
2402	-8.90	0.00	9.81	0.91	1.23	30.00	1000	29.09
2440	-9.55	0.00	9.82	0.27	1.06	30.00	1000	29.73
2480	-10.00	0.00	9.82	-0.18	0.96	30.00	1000	30.18

Sample Calculation:

Result = Reading + Attenuator Loss

*The equipment and cables were not used for factor 0 dB of the data sheets.

Average Output Power
(Reference data for RF Exposure)

Test place : Ise EMC Lab. No.3 Measurement Room
Report No. : 11163939H
Date : April 20, 2016
Temperature / Humidity : 23 deg. C / 45 % RH
Engineer : Koji Yamamoto
Mode : Tx BT LE

Freq. [MHz]	Reading [dBm]	Cable Loss [dB]	Atten. Loss [dB]	Result (Time average)		Duty factor [dB]	Result Burst power average	
				[dBm]	[mW]		[dBm]	[mW]
2402	-10.33	0.00	9.81	-0.52	0.89	0.00	-0.52	0.89
2440	-10.99	0.00	9.82	-1.17	0.76	0.00	-1.17	0.76
2480	-11.66	0.00	9.82	-1.84	0.65	0.00	-1.84	0.65

Sample Calculation:

Result (Time average) = Reading + Attenuator

Result (Burst power average) = Time average + Duty factor

*The equipment and cables were not used for factor 0 dB of the data sheets.

Burst rate confirmation

Test place Ise EMC Lab. No.1 Semi Anechoic Chamber
Report No. 11163939H
Date April 15, 2016
Temperature / Humidity 23 deg. C / 40 % RH
Engineer Hiroyuki Furutaka
Mode Tx BT LE

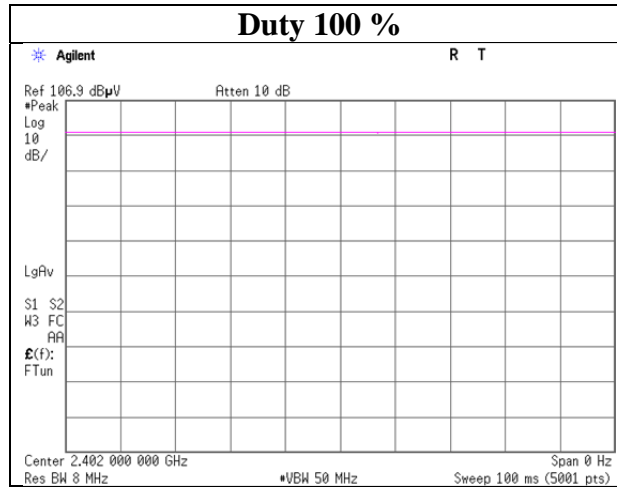

Radiated Spurious Emission

Test place Ise EMC Lab. No.3 Semi Anechoic Chamber
Report No. 11163939H
Date April 20, 2016 April 20, 2016 April 20, 2016
Temperature / Humidity 23 deg. C / 35 % RH 22 deg. C / 42 % RH 22 deg. C / 42 % RH
Engineer Ken Fujita Shinichi Miyazono Shinichi Miyazono
(30 MHz – 1000 MHz) (Above 1 GHz) (Below 30 MHz)
Mode Tx BT LE 2402 MHz

Below 30MHz

QP

Ant Deg [deg] or Polarity [Hori/Vert]	Frequency [MHz]	Detector	Reading [dBuV]	Ant Factor [dB/m]	Loss [dB]	Gain [dB]	Duty Factor [dB]	Result [dBuV/m]	Limit [dBuV/m]	Margin [dB]	Remark
0	5.99600	QP	30.0	19.4	-33.6	32.3	-	-16.5	29.5	46.0	Floor Noise

Result = Reading + Ant Factor + Loss (Cable + Attenuator + Filter + D.Factor) - Gain(Amplifier)

Above 30MHz

Polarity	Frequency [MHz]	Detector	Reading [dBuV]	Ant.Fac. [dB/m]	Loss [dB]	Gain [dB]	Result [dBuV/m]	Limit [dBuV/m]	Margin [dB]	Remark
Hori	37.495	QP	23.3	14.8	7.1	32.2	13.0	40.0	27.0	
Hori	68.497	QP	24.3	5.9	7.6	32.2	5.6	40.0	34.4	
Hori	132.886	QP	22.8	13.6	8.4	32.1	12.7	43.5	30.8	
Hori	257.716	QP	26.2	12.7	9.5	32.0	16.4	46.0	29.6	
Hori	488.578	QP	23.0	17.4	11.1	31.9	19.6	46.0	26.4	
Hori	953.509	QP	22.1	22.3	13.7	30.6	27.5	46.0	18.5	
Hori	2389.463	PK	49.3	26.9	6.8	32.7	50.3	73.9	23.6	
Hori	2390.000	PK	48.7	26.9	6.8	32.7	49.7	73.9	24.2	
Hori	4804.000	PK	43.5	31.8	9.0	31.8	52.5	73.9	21.4	
Hori	7206.000	PK	42.5	36.0	10.2	32.6	56.1	73.9	17.8	Floor Noise
Hori	9608.000	PK	42.3	38.2	9.6	33.2	56.9	73.9	17.0	Floor Noise
Hori	2389.463	AV	41.7	26.9	6.8	32.7	42.7	53.9	11.2	
Hori	2390.000	AV	41.0	26.9	6.8	32.7	42.0	53.9	11.9	
Hori	4804.000	AV	36.6	31.8	9.0	31.8	45.6	53.9	8.3	
Hori	7206.000	AV	33.9	36.0	10.2	32.6	47.5	53.9	6.4	Floor Noise
Hori	9608.000	AV	33.1	38.2	9.6	33.2	47.7	53.9	6.2	Floor Noise
Vert	36.814	QP	26.7	15.0	7.1	32.2	16.6	40.0	23.4	
Vert	68.838	QP	25.2	5.9	7.6	32.2	6.5	40.0	33.5	
Vert	132.546	QP	24.1	13.6	8.4	32.1	14.0	43.5	29.5	
Vert	257.716	QP	26.8	12.7	9.5	32.0	17.0	46.0	29.0	
Vert	490.181	QP	22.3	17.4	11.1	31.9	18.9	46.0	27.1	
Vert	953.509	QP	22.1	22.3	13.7	30.6	27.5	46.0	18.5	
Vert	2389.463	PK	48.1	26.9	6.8	32.7	49.1	73.9	24.8	
Vert	2390.000	PK	47.4	26.9	6.8	32.7	48.4	73.9	25.5	
Vert	4804.000	PK	44.3	31.8	9.0	31.8	53.3	73.9	20.6	
Vert	7206.000	PK	42.6	36.0	10.2	32.6	56.2	73.9	17.7	Floor Noise
Vert	9608.000	PK	42.4	38.2	9.6	33.2	57.0	73.9	16.9	Floor Noise
Vert	2389.463	AV	39.8	26.9	6.8	32.7	40.8	53.9	13.1	
Vert	2390.000	AV	39.4	26.9	6.8	32.7	40.4	53.9	13.5	
Vert	4804.000	AV	38.5	31.8	9.0	31.8	47.5	53.9	6.4	
Vert	7206.000	AV	34.0	36.0	10.2	32.6	47.6	53.9	6.3	Floor Noise
Vert	9608.000	AV	33.2	38.2	9.6	33.2	47.8	53.9	6.1	Floor Noise

Result = Reading + Ant Factor + Loss (Cable+Attenuator+Filter+Distance factor(above 1 GHz)) - Gain(Amplifier)

*Other frequency noises omitted in this report were not seen or had enough margin (more than 20 dB).

Distance factor: 1 GHz - 10 GHz $20\log(4.5\text{ m} / 3.0\text{ m}) = 3.5\text{ dB}$
10 GHz - 26.5 GHz $20\log(1.0\text{ m} / 3.0\text{ m}) = -9.5\text{ dB}$

20dBc Data Sheet

Polarity	Frequency [MHz]	Detector	Reading [dBuV]	Ant Factor [dB/m]	Loss [dB]	Gain [dB]	Result [dBuV/m]	Limit [dBuV/m]	Margin [dB]	Remark
Hori	2402.000	PK	99.0	26.9	6.8	32.7	100.0	-	-	Carrier
Hori	2400.000	PK	56.0	26.9	6.8	32.7	57.0	80.0	23.0	
Vert	2402.000	PK	95.7	26.9	6.8	32.7	96.7	-	-	Carrier
Vert	2400.000	PK	53.1	26.9	6.8	32.7	54.1	76.7	22.6	

Result = Reading + Ant Factor + Loss (Cable+Attenuator+Filter+Distance factor(above 1 GHz)) - Gain(Amplifier)

UL Japan, Inc.

Ise EMC Lab.

4383-326 Asama-cho, Ise-shi, Mie-ken 516-0021 JAPAN

Telephone : +81 596 24 8999

Facsimile : +81 596 24 8124

Radiated Spurious Emission (Reference Plot for band-edge)

Test place	Ise EMC Lab. No.3 Semi Anechoic Chamber
Report No.	11163939H
Date	April 20, 2016
Temperature / Humidity	22 deg. C / 42 % RH
Engineer	Shinichi Miyazono (1 GHz – 10 GHz)
Mode	Tx BT LE 2402 MHz

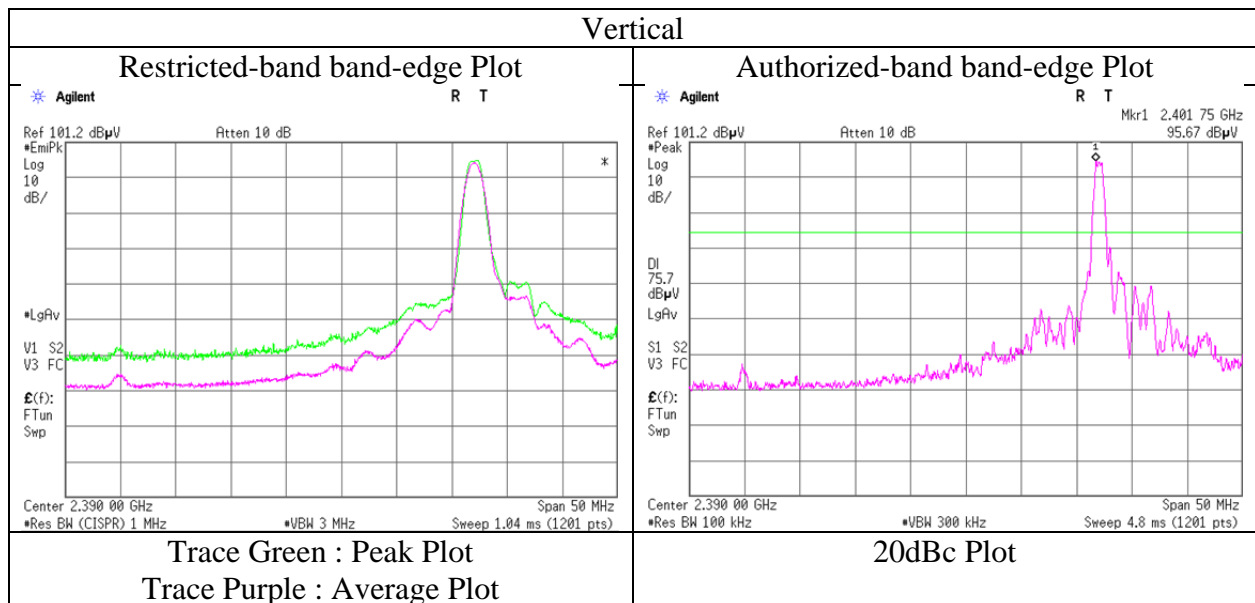
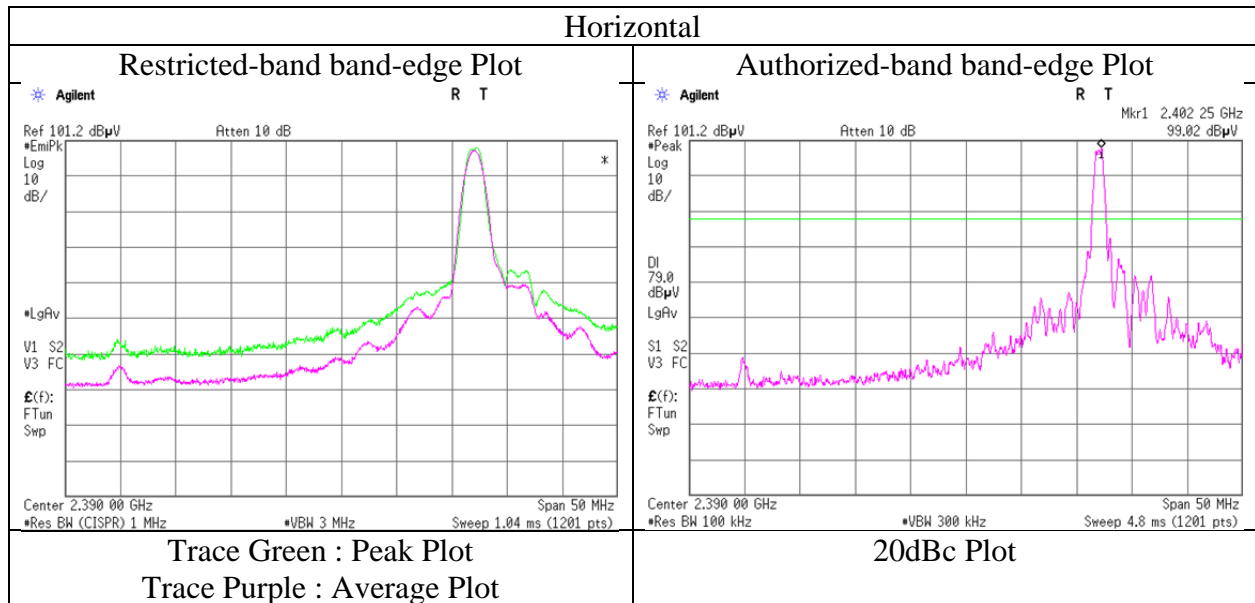

* Final result of restricted band edge was shown in tabular data.

Radiated Spurious Emission

Test place Ise EMC Lab. No.3 Semi Anechoic Chamber
Report No. 11163939H
Date April 20, 2016 April 20, 2016 April 20, 2016
Temperature / Humidity 23 deg. C / 35 % RH 22 deg. C / 42 % RH 22 deg. C / 42 % RH
Engineer Ken Fujita Shinichi Miyazono Shinichi Miyazono
(30 MHz – 1000 MHz) (Above 1 GHz) (Below 30 MHz)
Mode Tx BT LE 2440 MHz

Below 30MHz

QP

Ant Deg [deg] or Polarity [Hori/Vert]	Frequency [MHz]	Detector	Reading [dBuV]	Ant Factor [dB/m]	Loss [dB]	Gain [dB]	Duty Factor [dB]	Result [dBuV/m]	Limit [dBuV/m]	Margin [dB]	Remark
0	6.02000	QP	29.9	19.4	-33.6	32.3	-	-16.6	29.5	46.1	Floor Noise

Result = Reading + Ant Factor + Loss (Cable + Attenuator + Filter + D.Factor) - Gain(Amplifier)

Above 30MHz

Polarity	Frequency [MHz]	Detector	Reading [dBuV]	Ant.Fac. [dB/m]	Loss [dB]	Gain [dB]	Result [dBuV/m]	Limit [dBuV/m]	Margin [dB]	Remark
Hori	37.432	QP	23.5	14.8	7.1	32.2	13.2	40.0	26.8	
Hori	68.465	QP	24.5	5.9	7.6	32.2	5.8	40.0	34.2	
Hori	132.698	QP	22.9	13.6	8.4	32.1	12.8	43.5	30.7	
Hori	257.711	QP	26.4	12.7	9.5	32.0	16.6	46.0	29.4	
Hori	488.446	QP	23.3	17.4	11.1	31.9	19.9	46.0	26.1	
Hori	953.418	QP	22.3	22.3	13.7	30.6	27.7	46.0	18.3	
Hori	4880.000	PK	42.5	31.9	9.0	31.7	51.7	73.9	22.2	
Hori	7320.000	PK	42.6	36.0	10.3	32.6	56.3	73.9	17.6	Floor Noise
Hori	9760.000	PK	41.0	38.2	9.6	33.3	55.5	73.9	18.4	Floor Noise
Hori	4880.000	AV	34.9	31.9	9.0	31.7	44.1	53.9	9.8	
Hori	7320.000	AV	33.8	36.0	10.3	32.6	47.5	53.9	6.4	Floor Noise
Hori	9760.000	AV	32.6	38.2	9.6	33.3	47.1	53.9	6.8	Floor Noise
Vert	36.332	QP	26.4	15.2	7.1	32.2	16.5	40.0	23.5	
Vert	68.668	QP	25.4	5.9	7.6	32.2	6.7	40.0	33.3	
Vert	132.512	QP	24.3	13.5	8.4	32.1	14.1	43.5	29.4	
Vert	257.724	QP	26.5	12.7	9.5	32.0	16.7	46.0	29.3	
Vert	490.167	QP	22.4	17.4	11.1	31.9	19.0	46.0	27.0	
Vert	953.424	QP	22.4	22.3	13.7	30.6	27.8	46.0	18.2	
Vert	4880.000	PK	43.7	31.9	9.0	31.7	52.9	73.9	21.0	
Vert	7320.000	PK	42.7	36.0	10.3	32.6	56.4	73.9	17.5	Floor Noise
Vert	9760.000	PK	41.1	38.2	9.6	33.3	55.6	73.9	18.3	Floor Noise
Vert	4880.000	AV	37.2	31.9	9.0	31.7	46.4	53.9	7.5	
Vert	7320.000	AV	33.9	36.0	10.3	32.6	47.6	53.9	6.3	Floor Noise
Vert	9760.000	AV	32.7	38.2	9.6	33.3	47.2	53.9	6.7	Floor Noise

Result = Reading + Ant Factor + Loss (Cable+Attenuator+Filter+Distance factor(above 1 GHz)) - Gain(Amplifier)

*Other frequency noises omitted in this report were not seen or had enough margin (more than 20 dB).

Distance factor: 1 GHz - 10 GHz $20\log(4.5\text{ m} / 3.0\text{ m}) = 3.5\text{ dB}$
10 GHz - 26.5 GHz $20\log(1.0\text{ m} / 3.0\text{ m}) = -9.5\text{ dB}$

Radiated Spurious Emission

Test place Ise EMC Lab. No.3 Semi Anechoic Chamber
Report No. 11163939H
Date April 20, 2016 April 20, 2016 April 20, 2016
Temperature / Humidity 23 deg. C / 35 % RH 22 deg. C / 42 % RH 22 deg. C / 42 % RH
Engineer Ken Fujita Shinichi Miyazono Shinichi Miyazono
(30 MHz – 1000 MHz) (Above 1 GHz) (Below 30 MHz)
Mode Tx BT LE 2480 MHz

Below 30MHz

QP

Ant Deg [deg] or Polarity [Hori/Vert]	Frequency [MHz]	Detector	Reading [dBuV]	Ant Factor [dB/m]	Loss [dB]	Gain [dB]	Duty Factor [dB]	Result [dBuV/m]	Limit [dBuV/m]	Margin [dB]	Remark
0	5.00100	QP	29.9	19.5	-33.7	32.3	-	-16.6	29.5	46.1	Floor Noise

Result = Reading + Ant Factor + Loss (Cable + Attenuator + Filter + D.Factor) - Gain(Amplifier)

Above 30MHz

Polarity	Frequency [MHz]	Detector	Reading [dBuV]	Ant.Fac. [dB/m]	Loss [dB]	Gain [dB]	Result [dBuV/m]	Limit [dBuV/m]	Margin [dB]	Remark
Hori	37.482	QP	23.8	14.8	7.1	32.2	13.5	40.0	26.5	
Hori	68.487	QP	24.8	5.9	7.6	32.2	6.1	40.0	33.9	
Hori	132.812	QP	22.4	13.6	8.4	32.1	12.3	43.5	31.2	
Hori	257.722	QP	26.7	12.7	9.5	32.0	16.9	46.0	29.1	
Hori	488.598	QP	23.3	17.4	11.1	31.9	19.9	46.0	26.1	
Hori	953.512	QP	22.2	22.3	13.7	30.6	27.6	46.0	18.4	
Hori	2483.500	PK	55.1	26.9	6.8	32.6	56.2	73.9	17.7	
Hori	4960.000	PK	41.5	32.1	8.9	31.7	50.8	73.9	23.1	
Hori	7440.000	PK	44.2	36.0	10.2	32.7	57.7	73.9	16.2	Floor Noise
Hori	9920.000	PK	41.5	38.2	9.6	33.4	55.9	73.9	18.0	Floor Noise
Hori	2483.500	AV	48.9	26.9	6.8	32.6	50.0	53.9	3.9	
Hori	4960.000	AV	32.6	32.1	8.9	31.7	41.9	53.9	12.0	
Hori	7440.000	AV	32.7	36.0	10.2	32.7	46.2	53.9	7.7	Floor Noise
Hori	9920.000	AV	30.7	38.2	9.6	33.4	45.1	53.9	8.8	Floor Noise
Vert	36.822	QP	26.9	15.0	7.1	32.2	16.8	40.0	23.2	
Vert	68.838	QP	25.4	5.9	7.6	32.2	6.7	40.0	33.3	
Vert	132.368	QP	24.3	13.5	8.4	32.1	14.1	43.5	29.4	
Vert	257.718	QP	26.3	12.7	9.5	32.0	16.5	46.0	29.5	
Vert	490.178	QP	22.5	17.4	11.1	31.9	19.1	46.0	26.9	
Vert	953.513	QP	22.3	22.3	13.7	30.6	27.7	46.0	18.3	
Vert	2483.500	PK	52.6	26.9	6.8	32.6	53.7	73.9	20.2	
Vert	4960.000	PK	42.9	32.1	8.9	31.7	52.2	73.9	21.7	
Vert	7440.000	PK	44.3	36.0	10.2	32.7	57.8	73.9	16.1	Floor Noise
Vert	9920.000	PK	41.6	38.2	9.6	33.4	56.0	73.9	17.9	Floor Noise
Vert	2483.500	AV	47.2	26.9	6.8	32.6	48.3	53.9	5.6	
Vert	4960.000	AV	34.0	32.1	8.9	31.7	43.3	53.9	10.6	
Vert	7440.000	AV	32.8	36.0	10.2	32.7	46.3	53.9	7.6	Floor Noise
Vert	9920.000	AV	30.8	38.2	9.6	33.4	45.2	53.9	8.7	Floor Noise

Result = Reading + Ant Factor + Loss (Cable+Attenuator+Filter+Distance factor(above 1 GHz)) - Gain(Amplifier)

*Other frequency noises omitted in this report were not seen or had enough margin (more than 20 dB).

Distance factor: 1 GHz - 10 GHz $20\log(4.5\text{ m} / 3.0\text{ m}) = 3.5\text{ dB}$
10 GHz - 26.5 GHz $20\log(1.0\text{ m} / 3.0\text{ m}) = -9.5\text{ dB}$

Radiated Spurious Emission
(Reference Plot for band-edge)

Test place	Ise EMC Lab. No.3 Semi Anechoic Chamber
Report No.	11163939H
Date	April 20, 2016
Temperature / Humidity	22 deg. C / 42 % RH
Engineer	Shinichi Miyazono (1 GHz – 10 GHz)
Mode	Tx BT LE 2480 MHz

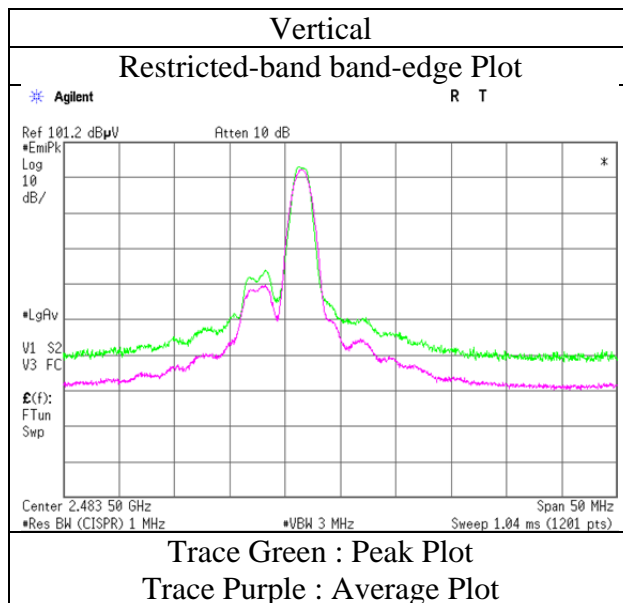
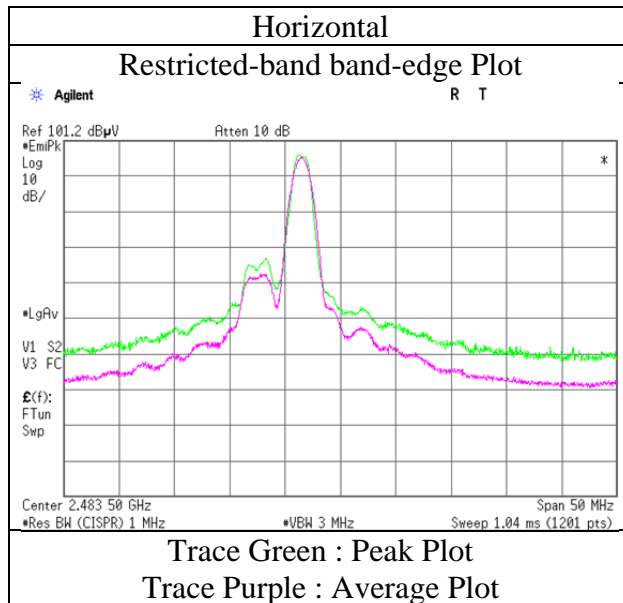

* Final result of restricted band edge was shown in tabular data.

Radiated Spurious Emission (Plot data, Worst case)

Test place	Ise EMC Lab. No.3 Semi Anechoic Chamber		
Report No.	11163939H		
Date	April 20, 2016	April 20, 2016	April 20, 2016
Temperature / Humidity	23 deg. C / 35 % RH	22 deg. C / 42 % RH	22 deg. C / 42 % RH
Engineer	Ken Fujita (30MHz - 1000MHz)	Shinichi Miyazono (Above 1GHz)	Shinichi Miyazono (Below 30MHz)
Mode	Tx BT LE 2402 MHz		

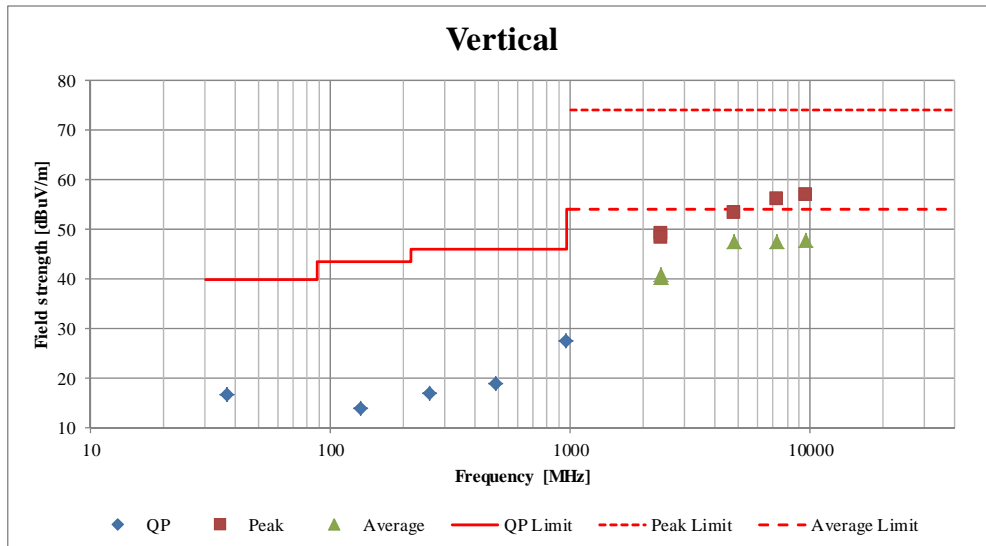
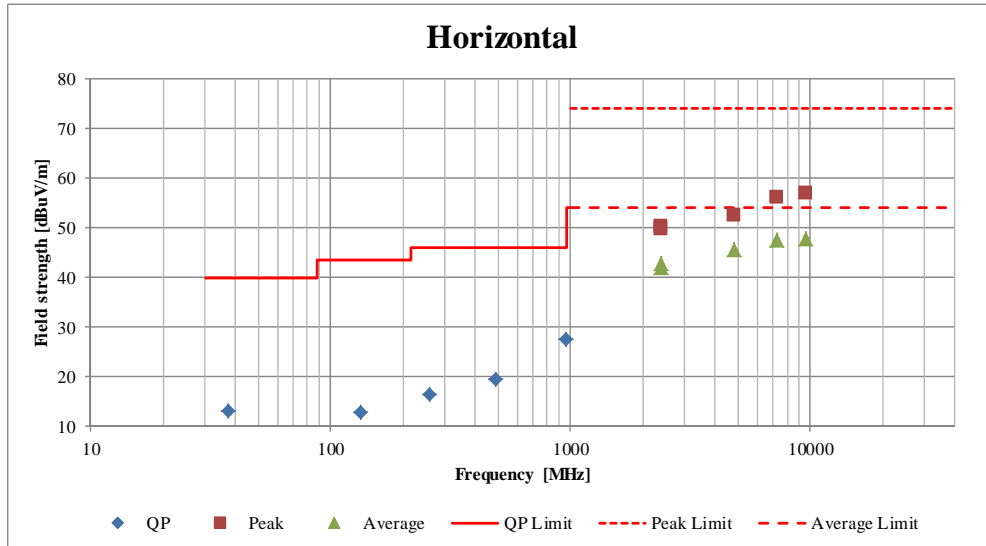

*These plots data contains sufficient number to show the trend of characteristic features for EUT.

Power Density

Test place Ise EMC Lab. No.3 Measurement Room
Report No. 11163939H
Date April 20, 2016
Temperature / Humidity 23 deg. C / 45 % RH
Engineer Koji Yamamoto
Mode Tx

BT LE

Freq. [MHz]	Reading [dBm]	Cable Loss [dB]	Atten. Loss [dB]	Result [dBm]	Limit [dBm]	Margin [dB]
2402	-23.77	0.31	9.81	-13.65	8.00	21.65
2440	-23.33	0.31	9.82	-13.20	8.00	21.20
2480	-23.89	0.32	9.81	-13.76	8.00	21.76

Sample Calculation:

Result = Reading + Cable Loss + Attenuator

Power Density

BT LE

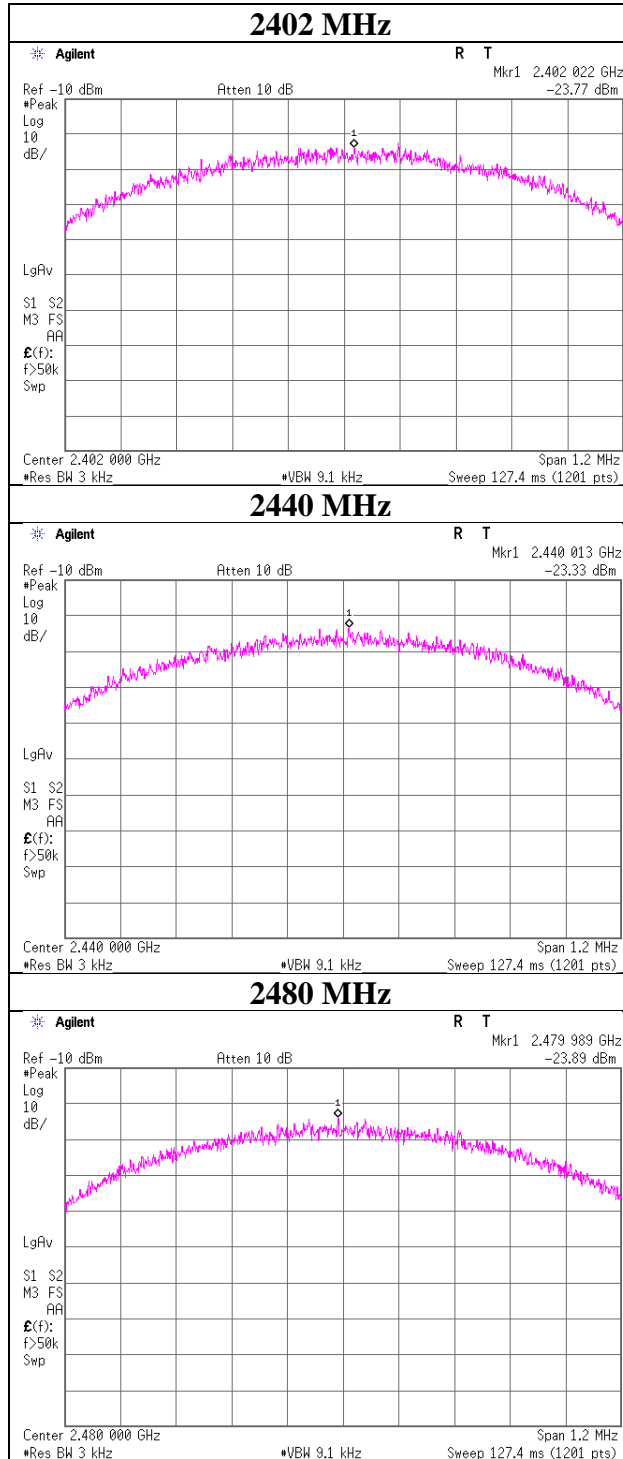

99%Occupied Bandwidth

Test place	Ise EMC Lab. No.3 Measurement Room
Report No.	11163939H
Date	April 20, 2016
Temperature / Humidity	23 deg. C / 45 % RH
Engineer	Koji Yamamoto
Mode	Tx

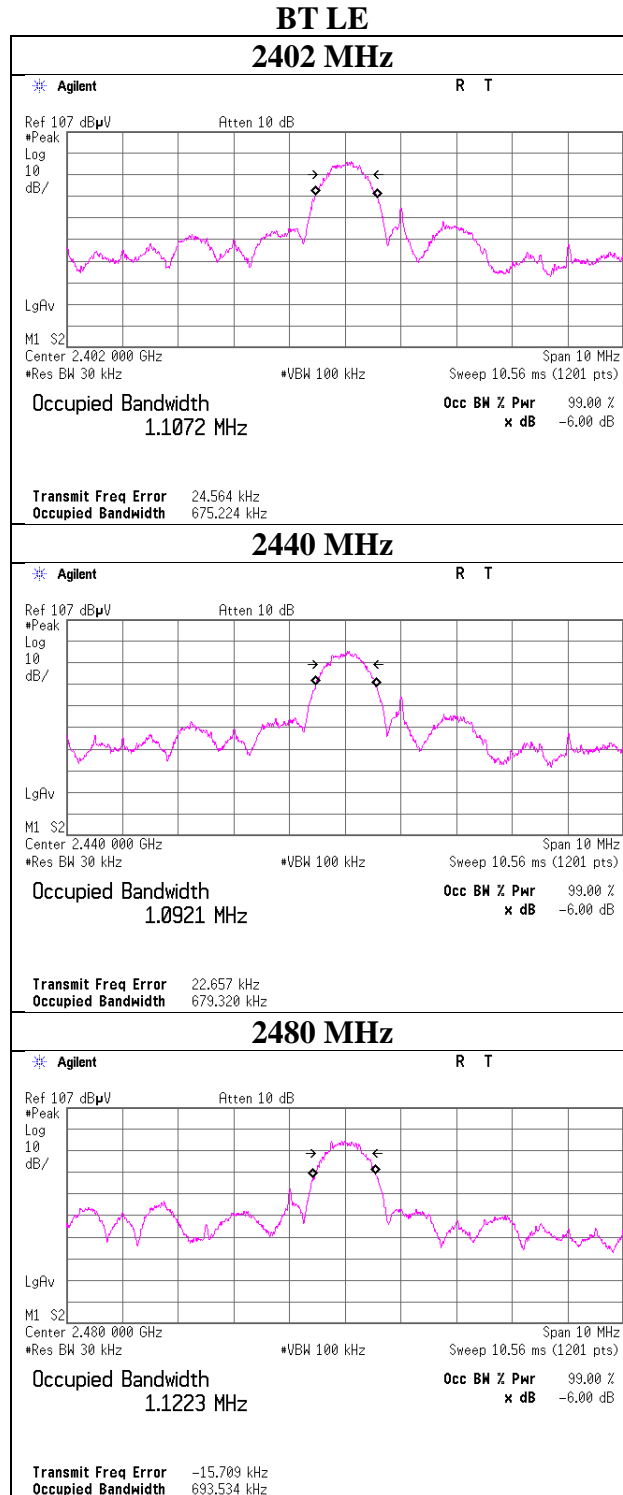

UL Japan, Inc.

Ise EMC Lab.

4383-326 Asama-cho, Ise-shi, Mie-ken 516-0021 JAPAN

Telephone : +81 596 24 8999

Facsimile : +81 596 24 8124

APPENDIX 2: Test instruments

Test equipment

Control No.	Instrument	Manufacturer	Model No	Serial No	Test Item	Calibration Date * Interval(month)
MAEC-04	Semi Anechoic Chamber(NSA)	TDK	Semi Anechoic Chamber 3m	DA-10005	RE	2015/10/02 * 12
MJM-26	Measure	KOMELON	KMC-36	-	RE	-
COTS-MEMI	EMI measurement program	TSJ	TEPTO-DV	-	RE	-
MTR-01	Test Receiver	Rohde & Schwarz	ESI40	100084	RE	2015/11/28 * 12
MBA-05	Biconical Antenna	Schwarzbeck	BBA9106	1302	RE	2015/11/02 * 12
MLA-23	Logperiodic Antenna(200-1000MHz)	Schwarzbeck	VUSLP9111B	911B-192	RE	2016/01/30 * 12
MCC-50	Coaxial Cable	UL Japan	-	-	RE	2015/06/19 * 12
MAT-68	Attenuator	Anritsu	MP721B	6200961025	RE	2015/11/12 * 12
MPA-14	Pre Amplifier	SONOMA INSTRUMENT	310	260833	RE	2016/03/18 * 12
MAEC-03	Semi Anechoic Chamber(NSA)	TDK	Semi Anechoic Chamber 3m	DA-10005	RE	2015/10/01 * 12
MOS-13	Thermo-Hygrometer	Custom	CTH-180	1301	RE	2016/01/21 * 12
MJM-16	Measure	KOMELON	KMC-36	-	RE	-
MHA-20	Horn Antenna 1-18GHz	Schwarzbeck	BBHA9120D	258	RE	2015/05/18 * 12
MCC-167	Microwave Cable	Junkosha	MWX221	1404S374(1m) / 1405S074(5m)	RE	2015/05/21 * 12
MPA-11	MicroWave System Amplifier	Agilent	83017A	MY39500779	RE	2016/03/24 * 12
MHA-16	Horn Antenna 15-40GHz	Schwarzbeck	BBHA9170	BBHA9170306	RE	2015/05/19 * 12
MMM-08	DIGITAL HiTESTER	Hioki	3805	051201197	RE	2016/01/13 * 12
MTR-08	Test Receiver	Rohde & Schwarz	ESCI	100767	RE	2015/09/02 * 12
MLPA-01	Loop Antenna	Rohde & Schwarz	HFH2-Z2	100017	RE	2015/10/24 * 12
MCC-112	Coaxial cable	Fujikura/Suhner/TSJ	5D-2W(10m)/ SFM141(3m)/ sucoform141-PE(1m)/ 421-010(1.5m)/ RFM-E321(Switcher)	-/00640	RE	2015/07/02 * 12
MCC-143	Coaxial Cable	UL Japan	-	-	RE	2015/06/24 * 12
MPA-13	Pre Amplifier	SONOMA INSTRUMENT	310	260834	RE	2016/03/24 * 12
MAT-70	Attenuator(6dB)	Agilent	8491A-006	MY52460153	RE	2016/04/05 * 12
MOS-15	Thermo-Hygrometer	Custom	CTH-180	1501	RE/AT	2016/01/21 * 12
MMM-10	DIGITAL HiTESTER	Hioki	3805	051201148	RE/AT	2016/01/18 * 12
MSA-10	Spectrum Analyzer	Agilent	E4448A	MY46180655	RE/AT	2016/02/24 * 12
MPM-13	Power Meter	Anritsu	ML2495A	0824014	AT	2015/11/11 * 12
MPSE-18	Power sensor	Anritsu	MA2411B	0738174	AT	2015/11/11 * 12
MCC-177	Microwave Cable	Junkosha	MMX221-00500DMS DMS	1502S304	AT	2016/03/10 * 12
MCC-64	Coaxial Cable	UL Japan	-	-	AT	2016/03/10 * 12
MAT-92	Attenuator	Weinschel Associates	WA56-10	56100308	AT	2015/06/01 * 12
MAT-10	Attenuator(10dB)	Weinschel Corp	2	BL1173	AT	2015/11/10 * 12

UL Japan, Inc.

Ise EMC Lab.

4383-326 Asama-cho, Ise-shi, Mie-ken 516-0021 JAPAN
Telephone : +81 596 24 8999
Facsimile : +81 596 24 8124

The expiration date of the calibration is the end of the expired month.

All equipment is calibrated with valid calibrations. Each measurement data is traceable to the national or international standards.

As for some calibrations performed after the tested dates, those test equipment have been controlled by means of an unbroken chains of calibrations.

**Test Item: RE: Radiated Emission test
AT: Antenna Terminal Conducted test**