



# RADIO TEST REPORT

**Test Report No. : 13692701S-B-R1**

**Applicant** : DENSO CORPORATION  
**Type of EUT** : Cockpit Control Unit  
**Model Number of EUT** : DNNS122  
**FCC ID** : HYQDNNS122  
**Test regulation** : FCC Part 15 Subpart C: 2021  
\*WLAN (2.4 GHz) part  
**Test Result** : Complied (Refer to SECTION 3)

1. This test report shall not be reproduced in full or partial, without the written approval of UL Japan, Inc.
2. The results in this report apply only to the sample tested.
3. This sample tested is in compliance with the limits of the above regulation.
4. The test results in this test report are traceable to the national or international standards.
5. This test report must not be used by the customer to claim product certification, approval, or endorsement by the A2LA accreditation body.
6. This test report covers Radio technical requirements.  
It does not cover administrative issues such as Manual or non-Radio test related Requirements. (if applicable)
7. The all test items in this test report are conducted by UL Japan, Inc. Shonan EMC Lab.
8. The opinions and the interpretations to the result of the description in this report are outside scopes where UL Japan has been accredited.
9. The information provided from the customer for this report is identified in SECTION 1.
10. This report is a revised version of 13692701S-B. 13692701S-B is replaced with this report.

**Date of test:** January 30 to March 12, 2021

**Representative test engineer:** *Y. Murakami*  
Yosuke Murakami  
Engineer

**Approved by:** *K. Takeyama*  
Kazutaka Takeyama  
Leader



CERTIFICATE 1266.03







- The testing in which "Non-accreditation" is displayed is outside the accreditation scopes in UL Japan.  
 There is no testing item of "Non-accreditation".

**UL Japan, Inc.**  
**Shonan EMC Lab.**

1-22-3 Megumigaoka, Hiratsuka-shi, Kanagawa-ken, 259-1220 JAPAN  
Telephone : +81 463 50 6400  
Facsimile : +81 463 50 6401

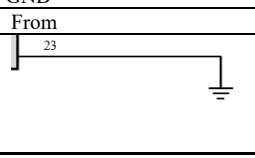
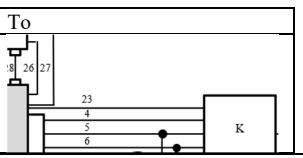
# REVISION HISTORY

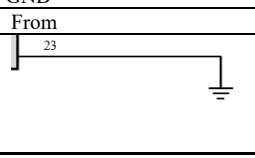
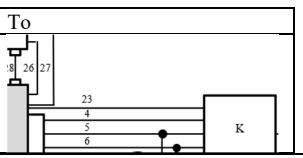
## Original Test Report No.: 13692701S-B

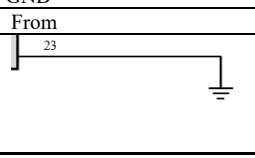
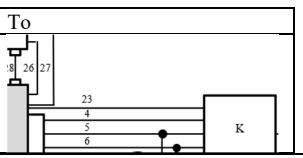
Revision	Test report No.	Date	Page revised	Contents								
- (Original)	13692701S-B	March 26, 2021	-	-								
1	13692701S-B-R1	June 25, 2021	1	Modification of remarks: From “*WLAN and Bluetooth Low Energy part” To “*WLAN (2.4 GHz) part” Change of approver: Kazuya Noda → Kazutaka Takeyama Removal of the division name “Consumer Technology Division”								
			6	Correction of clock frequency: 2 GHz → 40 MHz								
			7	Update of Test Specification: From “FCC Part 15 final revised on January 12, 2021 and effective February 11, 2021” To “FCC Part 15 final revised on May 3, 2021 and effective July 2, 2021” *The revision does not affect the test result conducted before its effective date.”								
			8	Update of the result in Section 3.2: Due to the modification of the worst margin at the Radiated Spurious Emission. Update of remarks to the FCC Part 15.31 (e): From “This EUT provides the stable voltage constantly to RF Part regardless of input voltage. Therefore, this EUT complies with the requirement.” To “The EUT provides stable voltage constantly to the wireless transmitter regardless of input voltage. Instead of a new battery, DC power supply was used for the test. Therefore, this EUT complies with the requirement.”								
			11 24-26 28-30 55-59	The description for chain 1 has been fixed because SISO is chain 0 only.								
			12	Modification of 4.2 Configuration and peripherals: <table border="1" style="width: 100%; border-collapse: collapse;"> <tr> <th style="width: 50%;">From</th> <th style="width: 50%;">To</th> </tr> <tr> <td style="text-align: center;"></td> <td style="text-align: center;"></td> </tr> </table> Correction of 4.2 Configuration and peripherals: Cable No.23 “GND” <table border="1" style="width: 100%; border-collapse: collapse;"> <tr> <th style="width: 50%;">From</th> <th style="width: 50%;">To</th> </tr> <tr> <td style="text-align: center;"></td> <td style="text-align: center;"></td> </tr> </table>	From	To			From	To		
			From	To								
												
			From	To								
												
			12-15	A block diagram for antenna terminal conducted tests was added to separate the radiated tests and the block diagram. Corrected the model name and added "No" before the serial number.								
			31	Fixed the description of rate from MCS 0 to MCS 8.								
33-51	Removal of the Radiated Spurious Emission data of AE.											
53	Removal of the Radiated Spurious Emission data of AE (Plot data, Worst case).											
57,59,61	Modification of Unit of measure: From “dBm” to “dBm/3 kHz”											

## Reference: Abbreviations (Including words undescribed in this report)

A2LA	The American Association for Laboratory Accreditation	MCS	Modulation and Coding Scheme
AC	Alternating Current	MRA	Mutual Recognition Arrangement
AFH	Adaptive Frequency Hopping	N/A	Not Applicable
AM	Amplitude Modulation	NIST	National Institute of Standards and Technology
Amp, AMP	Amplifier	NS	No signal detect.
ANSI	American National Standards Institute	NSA	Normalized Site Attenuation
Ant, ANT	Antenna	NVLAP	National Voluntary Laboratory Accreditation Program
AP	Access Point	OBW	Occupied Band Width
ASK	Amplitude Shift Keying	OFDM	Orthogonal Frequency Division Multiplexing
Atten., ATT	Attenuator	P/M	Power meter
AV	Average	PCB	Printed Circuit Board
BPSK	Binary Phase-Shift Keying	PER	Packet Error Rate
BR	Bluetooth Basic Rate	PHY	Physical Layer
BT	Bluetooth	PK	Peak
BT LE	Bluetooth Low Energy	PN	Pseudo random Noise
BW	BandWidth	PRBS	Pseudo-Random Bit Sequence
Cal Int	Calibration Interval	PSD	Power Spectral Density
CCK	Complementary Code Keying	QAM	Quadrature Amplitude Modulation
Ch., CH	Channel	QP	Quasi-Peak
CISPR	Comite International Special des Perturbations Radioelectriques	QPSK	Quadri-Phase Shift Keying
CW	Continuous Wave	RBW	Resolution Band Width
DBPSK	Differential BPSK	RDS	Radio Data System
DC	Direct Current	RE	Radio Equipment
D-factor	Distance factor	RF	Radio Frequency
DFS	Dynamic Frequency Selection	RMS	Root Mean Square
DQPSK	Differential QPSK	RSS	Radio Standards Specifications
DSSS	Direct Sequence Spread Spectrum	Rx	Receiving
EDR	Enhanced Data Rate	SA, S/A	Spectrum Analyzer
EIRP, e.i.r.p.	Equivalent Isotropically Radiated Power	SG	Signal Generator
EMC	ElectroMagnetic Compatibility	SVSWR	Site-Voltage Standing Wave Ratio
EMI	ElectroMagnetic Interference	TR	Test Receiver
EN	European Norm	Tx	Transmitting
ERP, e.r.p.	Effective Radiated Power	VBW	Video BandWidth
EU	European Union	Vert.	Vertical
EUT	Equipment Under Test	WLAN	Wireless LAN
Fac.	Factor		
FCC	Federal Communications Commission		
FHSS	Frequency Hopping Spread Spectrum		
FM	Frequency Modulation		
Freq.	Frequency		
FSK	Frequency Shift Keying		
GFSK	Gaussian Frequency-Shift Keying		
GNSS	Global Navigation Satellite System		
GPS	Global Positioning System		
Hori.	Horizontal		
ICES	Interference-Causing Equipment Standard		
IEC	International Electrotechnical Commission		
IEEE	Institute of Electrical and Electronics Engineers		
IF	Intermediate Frequency		
ILAC	International Laboratory Accreditation Conference		
ISED	Innovation, Science and Economic Development Canada		
ISO	International Organization for Standardization		
JAB	Japan Accreditation Board		
LAN	Local Area Network		
LIMS	Laboratory Information Management System		

**UL Japan, Inc.**

**Shonan EMC Lab.**

1-22-3 Megumigaoka, Hiratsuka-shi, Kanagawa-ken, 259-1220 JAPAN

Telephone : +81 463 50 6400

Facsimile : +81 463 50 6401

<b>CONTENTS</b>	<b>PAGE</b>
<b>SECTION 1: Customer information.....</b>	<b>5</b>
<b>SECTION 2: Equipment under test (EUT).....</b>	<b>5</b>
<b>SECTION 3: Test specification, procedures &amp; results.....</b>	<b>7</b>
<b>SECTION 4: Operation of EUT during testing.....</b>	<b>11</b>
<b>SECTION 5: Radiated Spurious Emission .....</b>	<b>16</b>
<b>SECTION 6: Antenna Terminal Conducted Tests.....</b>	<b>18</b>
<b>APPENDIX 1: Test data .....</b>	<b>19</b>
6 dB Bandwidth and 99 % Occupied Bandwidth.....	19
Maximum Peak Output Power .....	24
Average Output Power .....	28
Radiated Spurious Emission .....	33
Conducted Spurious Emission .....	54
Power Density .....	55
<b>APPENDIX 2: Test instruments .....</b>	<b>63</b>
<b>APPENDIX 3: Photographs of test setup .....</b>	<b>65</b>
Radiated Spurious Emission .....	65
Antenna Terminal Conducted Tests.....	66

## **SECTION 1: Customer information**

Company Name : DENSO CORPORATION  
Address : 1-1 Showa-cho, Kariya-shi, Aichi ken, 448-8661 Japan  
Telephone Number : +81-566-20-3304  
Facsimile Number : +81-566-25-4920  
Contact Person : Naoto Makino

The information provided from the customer is as follows;

- Applicant, Type of EUT, Model Number of EUT, FCC ID on the cover and other relevant pages
  - Operating/Test Mode(s) (Mode(s)) on all the relevant pages
  - SECTION 1: Customer information
  - SECTION 2: Equipment under test (EUT) other than the Receipt Date
  - SECTION 4: Operation of EUT during testing
- \* The laboratory is exempted from liability of any test results affected from the above information in SECTION 2 and 4.

## **SECTION 2: Equipment under test (EUT)**

### **2.1 Identification of EUT**

Type : Cockpit Control Unit  
Model Number : DNNS122  
Serial Number : Refer to SECTION 4.2  
Rating : DC 13.2 V  
Receipt Date : January 29, 2021  
Country of Mass-production : USA, JAPAN  
Condition : Production prototype  
(Not for Sale: This sample is equivalent to mass-produced items.)  
Modification : No Modification by the test lab.

## 2.2 Product Description

Model: DNNS122 (referred to as the EUT in this report) is a Cockpit Control Unit.

### Radio Specification

Clock frequency(Maximum) : 40 MHz

Bluetooth (BR/EDR)	
Frequency of operation	2402 MHz - 2480 MHz
Channel spacing	1 MHz
Modulation	FHSS (GFSK, $\pi/4$ -DQPSK, 8DPSK)
Antenna type	External Antenna
Antenna Gain	2.55 dBi (Max)

	IEEE802.11b	IEEE802.11g	IEEE802.11n (20 MHz band)	IEEE802.11n (40 MHz band)
Frequency of operation	2412 MHz - 2462 MHz	2412 MHz - 2462 MHz	2412 MHz - 2462 MHz 5180 MHz - 5240 MHz 5745 MHz - 5825 MHz	5190 MHz - 5230 MHz 5755 MHz - 5795 MHz
Channel spacing	5 MHz		2.4 GHz band 5 MHz 5 GHz band 20 MHz	5 GHz band 40 MHz
Modulation	DSSS: DBPSK, DQPSK, CCK	OFDM: BPSK, QPSK, 16QAM, 64QAM		
	IEEE802.11a	IEEE802.11ac (20 MHz band)	IEEE802.11ac (40 MHz band)	IEEE802.11ac (80 MHz band)
Frequency of operation	5180 MHz - 5240 MHz 5745 MHz - 5825 MHz	5180 MHz - 5240 MHz 5745 MHz - 5825 MHz	5190 MHz - 5230 MHz 5755 MHz - 5795 MHz	5210 MHz 5775 MHz
Channel spacing	20 MHz		40 MHz	80 MHz
Modulation	OFDM BPSK, QPSK, 16QAM, 64QAM, 256QAM (*256QAM is only for IEEE802.11ac 80 MHz band)			
Antenna type	External Antenna			
Antenna Gain	Main Antenna: Chain0 : 2.55 dBi (2.4 GHz), 0.02 dBi (5 GHz) Sub Antenna: Chain1 : -2.10 dBi (2.4 GHz), -5.26 dBi (5 GHz)			

### [AM/FM (incl.RBDS)/XM Radio]

	AM	FM (incl. RBDS)	XM
Equipment type	Receiver		
Frequency of operation	530 kHz to 1710 kHz	87.75 MHz to 107.9 MHz	2333.465 MHz to 2344.045 MHz

FM tuner specification

Intermediate frequency: 220 kHz

**UL Japan, Inc.**

**Shonan EMC Lab.**

1-22-3 Megumigaoka, Hiratsuka-shi, Kanagawa-ken, 259-1220 JAPAN

Telephone : +81 463 50 6400

Facsimile : +81 463 50 6401

### **SECTION 3: Test specification, procedures & results**

#### **3.1 Test Specification**

Test Specification : FCC Part 15 Subpart C  
FCC Part 15 final revised on May 3, 2021 and effective July 2, 2021  
\*The revision does not affect the test result conducted before its effective date.

Title : FCC 47 CFR Part 15 Radio Frequency Device Subpart C Intentional Radiators  
Section 15.207 Conducted limits  
Section 15.247 Operation within the bands 902-928 MHz, 2400-2483.5 MHz,  
and 5725-5850 MHz

### 3.2 Procedures and results

Item	Test Procedure	Specification	Worst margin	Results	Remarks
Conducted Emission	FCC: ANSI C63.10-2013 6. Standard test methods ISED: RSS-Gen 8.8	FCC: Section 15.207 ----- ISED: RSS-Gen 8.8	-	N/A	*1)
6 dB Bandwidth	FCC: KDB 558074 D01 15.247 Meas Guidance v05r02 ISED: -	FCC: Section 15.247(a)(2) ----- ISED: RSS-247 5.2(a)	See data.	Complied a)	Conducted
Maximum Peak Output Power	FCC: KDB 558074 D01 15.247 Meas Guidance v05r02 ISED: RSS-Gen 6.12	FCC: Section 15.247(b)(3) ----- ISED: RSS-247 5.4(d)		Complied b)	Conducted
Power Density	FCC: KDB 558074 D01 15.247 Meas Guidance v05r02 ISED: -	FCC: Section 15.247(e) ----- ISED: RSS-247 5.2(b)		Complied c)	Conducted
Spurious Emission Restricted Band Edges	FCC: KDB 558074 D01 15.247 Meas Guidance v05r02 ISED: RSS-Gen 6.13	FCC: Section 15.247(d) ----- ISED: RSS-247 5.5 RSS-Gen 8.9 RSS-Gen 8.10	4.1 dB 9848.000 MHz, AV, Vert. Tx 11n-20 MIMO 2462 MHz	Complied# d), e)	Conducted (below 30 MHz)/ Radiated (above 30 MHz) *2)
<p>Note: UL Japan, Inc.'s EMI Work Procedures No. 13-EM-W0420 and 13-EM-W0422.  *1) The test was not applicable since the EUT does not have AC mains.  *2) Radiated test was selected over 30 MHz based on section 15.247(d) and KDB 558074 D01 15.247 Meas Guidance v05r02 8.5 and 8.6.  a) Refer to APPENDIX 1 (data of 6 dB Bandwidth and 99 % Occupied Bandwidth)  b) Refer to APPENDIX 1 (data of Maximum Peak Output Power)  c) Refer to APPENDIX 1 (data of Power Density)  d) Refer to APPENDIX 1 (data of Conducted Spurious Emission)  e) Refer to APPENDIX 1 (data of Radiated Spurious Emission)</p> <p>Symbols:  Complied                The data of this test item has enough margin, more than the measurement uncertainty.  Complied#              The data of this test item meets the limits unless the measurement uncertainty is taken into consideration.</p>					

\* In case any questions arise about test procedure, ANSI C63.10: 2013 is also referred.

#### **FCC Part 15.31 (e)**

The EUT provides stable voltage constantly to the wireless transmitter regardless of input voltage. Instead of a new battery, DC power supply was used for the test. Therefore, this EUT complies with the requirement.

#### **FCC Part 15.203 Antenna requirement**

It is impossible for end users to replace the antenna, because the antenna is mounted inside of the vehicle. Therefore, the equipment complies with the antenna requirement of Section 15.203.

**UL Japan, Inc.**

**Shonan EMC Lab.**

1-22-3 Megumigaoka, Hiratsuka-shi, Kanagawa-ken, 259-1220 JAPAN

Telephone : +81 463 50 6400

Facsimile : +81 463 50 6401



### 3.3 Addition to standard

Item	Test Procedure	Specification	Worst margin	Results	Remarks
99 % Occupied Bandwidth	ISED: RSS-Gen 6.7	ISED: -	N/A	- a)	Conducted
a) Refer to APPENDIX 1 (data of 6 dB Bandwidth, 99 % Occupied Bandwidth and Carrier Frequency Separation)					

Other than above, no addition, exclusion nor deviation has been made from the standard.

### 3.4 Uncertainty

There is no applicable rule of uncertainty in this applied standard. Therefore, the results are derived depending on whether or not laboratory uncertainty is applied.

The following uncertainties have been calculated to provide a confidence level of 95 % using a coverage factor  $k=2$ .

Shonan EMC Lab.

Item	Frequency range	Uncertainty (+/-)			
		No. 1 SAC / SR	No. 2 SAC / SR	No. 3 SAC / SR	No. 4,5,6,8 SR
Conducted emission (AC Mains) LISN	150 kHz-30 MHz	2.6 dB	2.6 dB	2.56dB	2.9 dB
Radiated emission (Measurement distance: 3 m)	9 kHz-30 MHz	3.0 dB	2.7 dB	2.7 dB	-
	30 MHz-200 MHz	4.6 dB	4.6 dB	4.6 dB	-
	200 MHz-1 GHz	6.0 dB	6.0 dB	6.0 dB	-
	1 GHz-6 GHz	4.8 dB	4.8 dB	4.8 dB	-
	6 GHz-18 GHz	5.4 dB	5.4 dB	5.4 dB	-
	18 GHz-40 GHz	5.3 dB	5.3 dB	5.3 dB	-
Radiated emission (Measurement distance: 1 m)	1 GHz-18 GHz	5.7 dB	5.7 dB	5.7 dB	-
	18 GHz-40 GHz	5.6 dB	5.6 dB	5.6 dB	-

SAC=Semi-Anechoic Chamber

SR= Shielded Room is applied besides radiated emission

Antenna terminal test	Uncertainty (+/-)
Power Measurement above 1 GHz (Average Detector)_SPM-06	1.4 dB
Power Measurement above 1 GHz (Peak Detector)_SPM-06	1.6 dB
Power Measurement above 1 GHz (Average Detector)_SPM-07	0.89 dB
Power Measurement above 1 GHz (Peak Detector)_SPM-07	1.2 dB
Power Measurement above 1 GHz (Average Detector)_SPM-13	0.91 dB
Power Measurement above 1 GHz (Peak Detector)_SPM-13	1.2 dB
Spurious emission (Conducted) below 1GHz	0.87 dB
Spurious emission (Conducted) 1 GHz-3 GHz	0.96 dB
Spurious emission (Conducted) 3 GHz-18 GHz	3.0 dB
Spurious emission (Conducted) 18 GHz-26.5 GHz	2.6 dB
Spurious emission (Conducted) 26.5 GHz-40 GHz	2.2 dB
Bandwidth Measurement	0.012 %
Duty cycle and Time Measurement	0.27 %
Temperature_SCH-01	0.87 deg.C.
Humidity_SCH-01	4.3 %
Temperature_SCH-02	2.0 deg.C.
Humidity_SCH-02	6.6 %
Voltage	0.86 %

**UL Japan, Inc.**

**Shonan EMC Lab.**

1-22-3 Megumigaoka, Hiratsuka-shi, Kanagawa-ken, 259-1220 JAPAN

Telephone : +81 463 50 6400

Facsimile : +81 463 50 6401

### 3.5 Test Location

UL Japan, Inc. Shonan EMC Lab.

1-22-3, Megumigaoka, Hiratsuka-shi, Kanagawa-ken 259-1220 JAPAN

Telephone: +81 463 50 6400, Facsimile: +81 463 50 6401

A2LA Certificate Number: 1266.03

(FCC test firm registration number: 626366, ISED lab company number: 2973D / CAB identifier: JP0001)

Test site	IC Registration Number	Width x Depth x Height (m)	Size of reference ground plane (m) / horizontal conducting plane	Maximum measurement distance
No.1 Semi-anechoic chamber	2973D-1	20.6 x 11.3 x 7.65	20.6 x 11.3	10 m
No.2 Semi-anechoic chamber	2973D-2	20.6 x 11.3 x 7.65	20.6 x 11.3	10 m
No.3 Semi-anechoic chamber	2973D-3	12.7 x 7.7 x 5.35	12.7 x 7.7	5 m
No.4 Semi-anechoic chamber	-	8.1 x 5.1 x 3.55	8.1 x 5.1	-
No.1 Shielded room	-	6.8 x 4.1 x 2.7	6.8 x 4.1	-
No.2 Shielded room	-	6.8 x 4.1 x 2.7	6.8 x 4.1	-
No.3 Shielded room	-	6.3 x 4.7 x 2.7	6.3 x 4.7	-
No.4 Shielded room	-	4.4 x 4.7 x 2.7	4.4 x 4.7	-
No.5 Shielded room	-	7.8 x 6.4 x 2.7	7.8 x 6.4	-
No.6 Shielded room	-	7.8 x 6.4 x 2.7	7.8 x 6.4	-
No.8 Shielded room	-	3.45 x 5.5 x 2.4	3.45 x 5.5	-
No.1 Measurement room	-	2.55 x 4.1 x 2.5	-	-

### 3.6 Test data, Test instruments, and Test set up

Refer to APPENDIX.

## **SECTION 4: Operation of EUT during testing**

### **4.1 Operating Mode(s)**

Test operating mode was determined as follows according to “Section 1 of 6 802.11 a/b/g/n testing - Managing Complex Regulatory Approvals - ” of TCB Council Workshop October 2009.

<b>Mode</b>	<b>Remarks*</b>
IEEE 802.11b (11b)	11 Mbps, PN9
IEEE 802.11g (11g)	24 Mbps, PN9
IEEE 802.11n SISO 20 MHz BW (11n-20 SISO)	MCS 6, PN9
IEEE 802.11n MIMO 20 MHz BW (11n-20 MIMO)	MCS 14, PN9
*Power of the EUT was set by the software as follows; Power settings *1): 11b:14 dBm,11g/11n20 SISO/11n-20 MIMO:11 dBm Software: MSoC Ver.F61WHM010-708(Date:2020.Nov-12th) (Storage location: EUT memory)	
*This setting of software is the worst case. Any conditions under the normal use do not exceed the condition of setting. In addition, end users cannot change the settings of the output power of the product.	
*1) The power setting values on this table are testing software's settings, therefore it does not represents actual power output level of the product.	

\*The details of Operating mode(s)

<b>Test Item</b>	<b>Operating Mode</b>	<b>Tested Antenna</b>	<b>Tested frequency</b>
Radiated Spurious Emission (Below 1 GHz)	11n-20 MIMO Tx	Chain 0 + Chain 1	2412 MHz
Radiated Spurious Emission (Above 1 GHz)	11b Tx 11g Tx 11n-20 SISO Tx	Chain 0	2412 MHz 2437 MHz 2462 MHz
	11n-20 MIMO Tx	Chain 0 + Chain 1	2412 MHz 2437 MHz 2462 MHz
Conducted Spurious Emission	11n-20 MIMO Tx	Chain 0	2412 MHz
6 dB Bandwidth 99 % Occupied Bandwidth	11b Tx 11g Tx 11n-20 SISO Tx 11n-20 MIMO Tx	Chain 0	2412 MHz 2437 MHz 2462 MHz
	11b Tx 11g Tx 11n-20 SISO Tx	Chain 0	2412 MHz 2437 MHz 2462 MHz
Maximum Peak Output Power Power Density	11n-20 MIMO Tx	Chain 0 + Chain 1	2412 MHz 2437 MHz 2462 MHz

4.2 Configuration and peripherals

<Radiated Emission test>

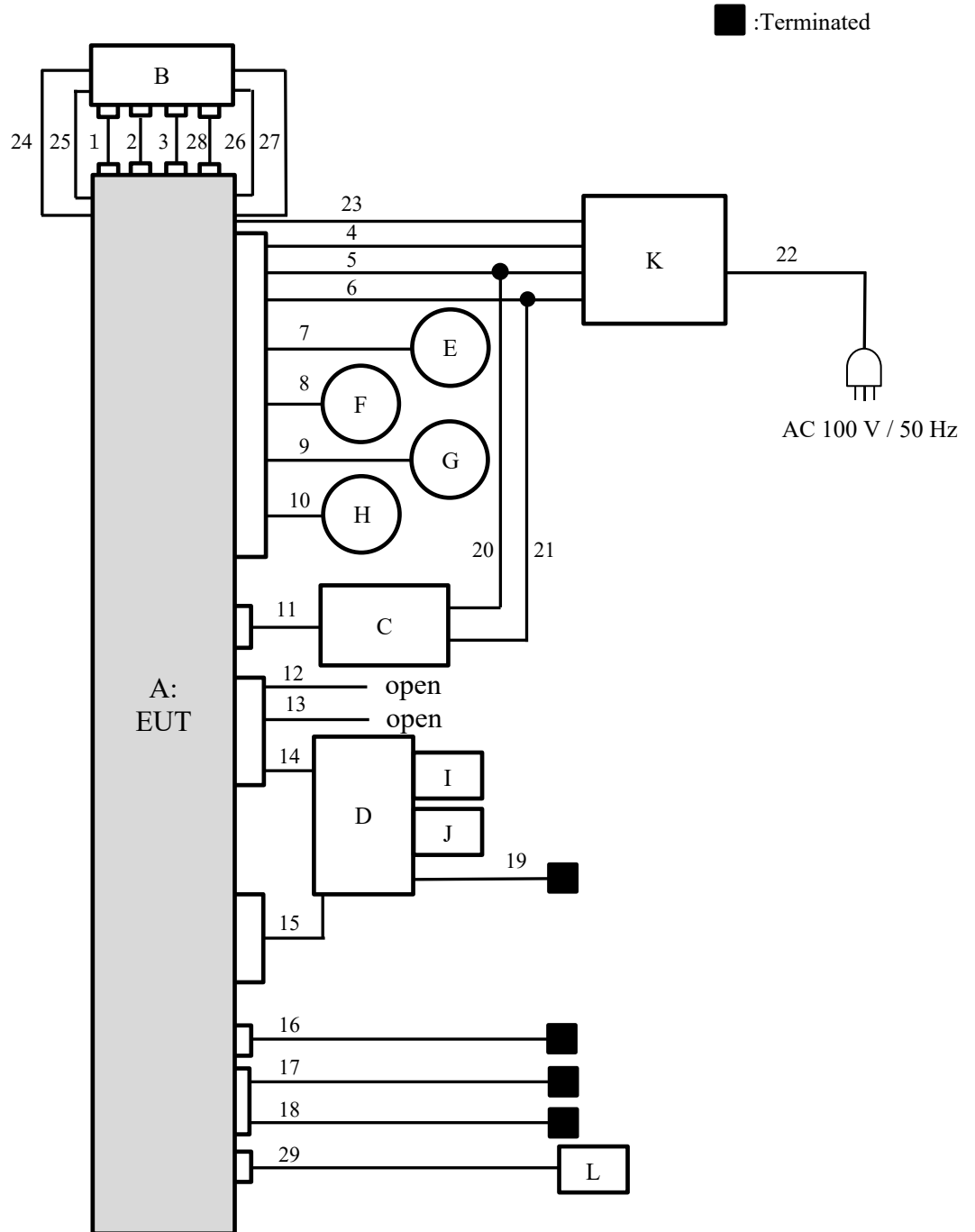

\* Cabling and setup(s) were taken into consideration and test data was taken under worse case conditions.

**Description of EUT and Support equipment**

No.	Item	Model number	Serial number	Manufacturer	Remarks
A	Cockpit Control Unit	DNNS122	CP1.5-K3-GZ1-US-High-064	DENSO CORPORATION	EUT
B	Center Information Display	DNNS132	GZ1-SD-HM LHD-077	DENSO CORPORATION	-
C	Meter	85002AN02A	-	DENSO CORPORATION	-
D	AUX-BOX	86257 AN00A	No.5	HOSIDEN	-
E	Speaker L	20FHI-SPRE-03	-	DENSO CORPORATION	-
F	Speaker R	20FHI-SPRE-03	-	DENSO CORPORATION	-
G	Speaker Rear L	20FHI-SPRE-03	-	DENSO CORPORATION	-
H	Speaker Rear R	20FHI-SPRE-03	-	DENSO CORPORATION	-
I	USB Memory	USM4GL-W	-	SONY	-
J	USB Memory	USM4GU	-	SONY	-
K	DC Power supply	PAN60-10A	NL002383	KIKUSUI	-
L	GPS Antenna	86277AL150	03590033	SUBARU	-

**List of cables used**

No.	Name	Length (m)	Shield		Remarks
			Cable	Connector	
1	CCU-CID-POW	0.2	Unshielded	Unshielded	-
2	CCU-CID-LVDS	0.2	Unshielded	Unshielded	-
3	CCU-CID-BT	0.2	Unshielded	Unshielded	-
4	DC power(+B)	1.8	Unshielded	Unshielded	-
5	DC power(+IG)	1.8	Unshielded	Unshielded	-
6	DC power(GND)	1.8	Unshielded	Unshielded	-
7	Speaker L	1.8	Unshielded	Unshielded	-
8	Speaker R	1.8	Unshielded	Unshielded	-
9	Speaker Rear L	1.8	Unshielded	Unshielded	-
10	Speaker Rear R	1.8	Unshielded	Unshielded	-
11	Meter	1.8	Unshielded	Unshielded	-
12	USB(Blue)	1.5	Shielded	Shielded	-
13	USB(Brown)	0.15	Shielded	Shielded	-
14	USB(Green)	0.5	Shielded	Shielded	-
15	Power Supply	1.0	Unshielded	Unshielded	-
16	XM	1.0	Shielded	Shielded	-
17	AM/FM	2.0	Shielded	Shielded	-
18	AM/FM	2.0	Shielded	Shielded	-
19	Mini Jack	2.0	Unshielded	Unshielded	-
20	DC power(+IG)	1.2	Unshielded	Unshielded	-
21	DC power(GND)	1.2	Unshielded	Unshielded	-
22	AC	3.0	Unshielded	Unshielded	-
23	GND	2.4	Unshielded	Unshielded	-
24	GND	0.2	Unshielded	Unshielded	-
25	GND	0.2	Unshielded	Unshielded	-
26	GND	0.2	Unshielded	Unshielded	-
27	GND	0.2	Unshielded	Unshielded	-
28	CCU-CID-Wifi	0.2	Unshielded	Unshielded	-
29	GPS	0.8	Shielded	Shielded	-

**UL Japan, Inc.**

**Shonan EMC Lab.**

1-22-3 Megumigaoka, Hiratsuka-shi, Kanagawa-ken, 259-1220 JAPAN

Telephone : +81 463 50 6400

Facsimile : +81 463 50 6401

<Antenna Terminal Conducted test>

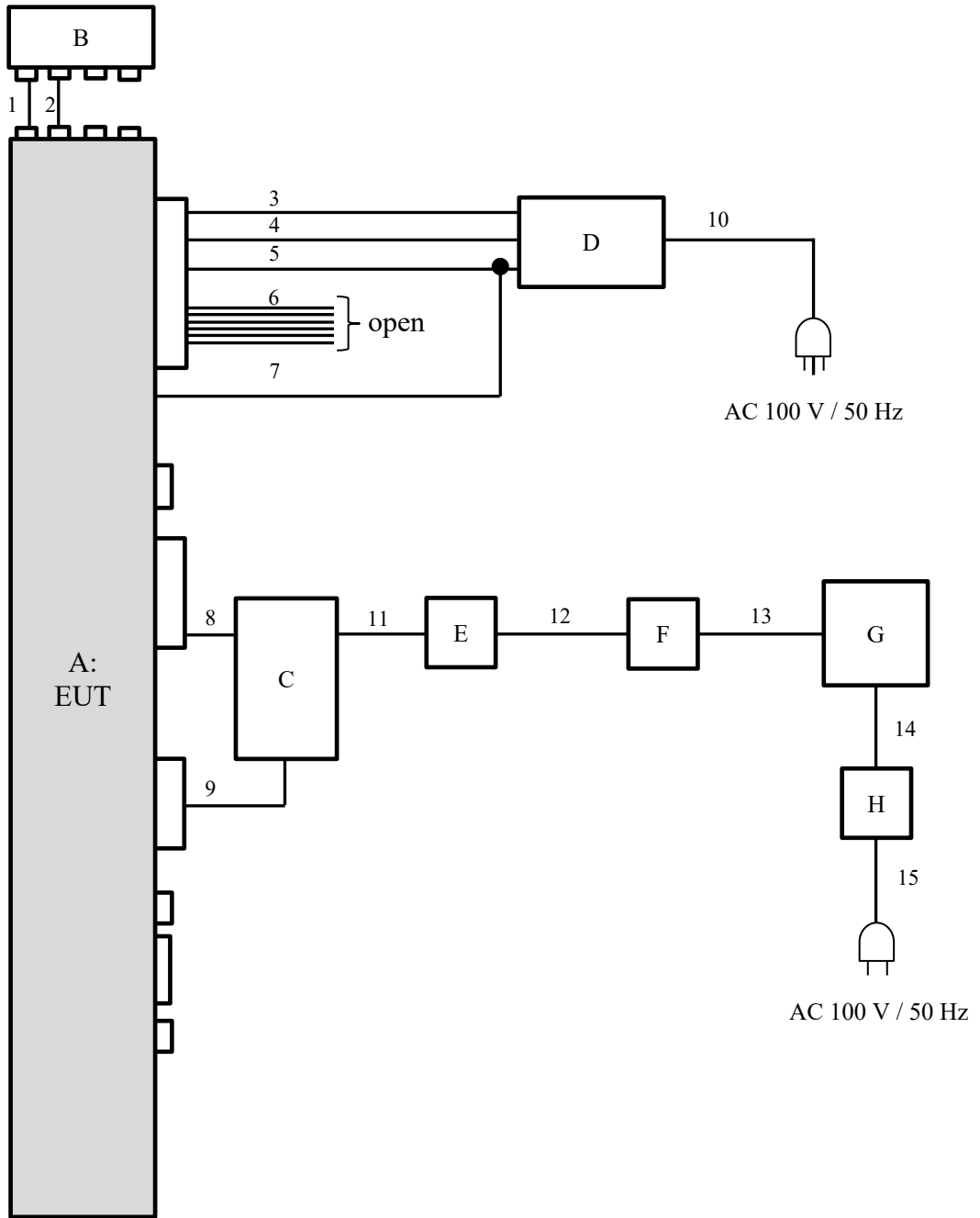

**Description of EUT and Support equipment**

No.	Item	Model number	Serial number	Manufacturer	Remarks
A	Cockpit Control Unit	DNNS122	CP1.5-K3-GZ1-US-High-065	DENSO CORPORATION	EUT
B	Center Information Display	DNNS132	GZ1-SD-HM LHD-077	DENSO CORPORATION	-
C	AUX-BOX	86257 AN00A	No.2	HOSIDEN	-
D	DC Power supply	PAN35-10A	ML002085	KIKUSUI	-
E	USB-LAN Converter	LUA3-U2-ATX	26495680102812	Buffalo	-
F	USB-LAN Converter	LUA3-U2-ATX	26495680815712	Buffalo	-
G	Laptop PC	ThinkPad L580	PF-1PLZHX 19/05	Lenovo	-
H	AC Adaptor	ADLX45YCC2A	8SSA10E75844C1SG94BG7T0	Lenovo	-

**List of cables used**

No.	Name	Length (m)	Shield		Remarks
			Cable	Connector	
1	CCU-CID-POW	1.0	Unshielded	Unshielded	-
2	CCU-CID-LVDS	2.0	Unshielded	Unshielded	-
3	DC power(+B)	1.8	Unshielded	Unshielded	-
4	DC power(+IG)	1.8	Unshielded	Unshielded	-
5	DC power(GND)	1.8	Unshielded	Unshielded	-
6	Signal	1.0	Unshielded	Unshielded	-
7	GND	2.4	Unshielded	Unshielded	-
8	USB(Green)	0.5	Shielded	Shielded	-
9	Power Supply	1.0	Unshielded	Unshielded	-
10	AC	3.0	Unshielded	Unshielded	-
11	USB	0.4	Shielded	Shielded	-
12	LAN	2.0	Shielded	Shielded	-
13	USB	0.4	Shielded	Shielded	-
14	DC	1.0	Unshielded	Unshielded	-
15	AC	1.8	Unshielded	Unshielded	-

**UL Japan, Inc.**

**Shonan EMC Lab.**

1-22-3 Megumigaoka, Hiratsuka-shi, Kanagawa-ken, 259-1220 JAPAN

Telephone : +81 463 50 6400

Facsimile : +81 463 50 6401

## **SECTION 5: Radiated Spurious Emission**

### **Test Procedure**

It was measured based on "8.5 and 8.6 of KDB 558074 D01 15.247 Meas Guidance v05r02".

[For below 1 GHz]

EUT was placed on a urethane platform of nominal size, 1.0 m by 1.5 m, raised 0.8 m above the conducting ground plane. The Radiated Electric Field Strength has been measured in a Semi Anechoic Chamber with a ground plane.

[For above 1 GHz]

EUT was placed on a urethane platform of nominal size, 0.5 m by 0.5 m, raised 1.5 m above the conducting ground plane. The Radiated Electric Field Strength has been measured in a Semi Anechoic Chamber with absorbent materials lined on a ground plane.

The height of the measuring antenna varied between 1 m and 4 m and EUT was rotated a full revolution in order to obtain the maximum value of the electric field strength.

Test antenna was aimed at the EUT for receiving the maximum signal and always kept within the illumination area of the 3 dB beamwidth of the antenna.

The measurements were performed for both vertical and horizontal antenna polarization with the Test Receiver, or the Spectrum Analyzer.

The measurements were made with the following detector function of the test receiver and the Spectrum analyzer (in linear mode).

The test was made with the detector (RBW/VBW) in the following table.

When using Spectrum analyzer, the test was made with adjusting span to zero by using peak hold.

### **Test Antennas are used as below;**

Frequency	30 MHz to 200 MHz	200 MHz to 1 GHz	Above 1 GHz
Antenna Type	Biconical	Logperiodic	Horn

In any 100 kHz bandwidth outside the restricted band in which the spread spectrum intentional radiator is operating, the radio frequency power that is produced by the intentional radiator confirmed 20 dB below that in the 100 kHz bandwidth within the band that contains the highest level of the desired power, based on a radiated measurement.

### **20 dBc was applied to the frequency over the limit of FCC 15.209 / Table 4 of RSS-Gen 8.9(ISED) and outside the restricted band of FCC15.205 / Table 6 of RSS-Gen 8.10 (ISED).**

Frequency	Below 1 GHz	Above 1 GHz		20 dBc
Instrument used	Test Receiver	Spectrum Analyzer		Spectrum Analyzer
Detector	QP	PK	AV *1)	PK
IF Bandwidth	BW 120 kHz	RBW: 1 MHz VBW: 3 MHz	11.12.2.5.3 RBW: 1 MHz VBW: 1/T (T: burst length, refer to Burst rate confirmation sheet) Detector: Peak	RBW: 100 kHz VBW: 300 kHz

\*1) Average Power Measurement was performed based on ANSI C63.10-2013.

**UL Japan, Inc.**

**Shonan EMC Lab.**

1-22-3 Megumigaoka, Hiratsuka-shi, Kanagawa-ken, 259-1220 JAPAN

Telephone : +81 463 50 6400

Facsimile : +81 463 50 6401



**Figure 2: Test Setup**

Below 1 GHz

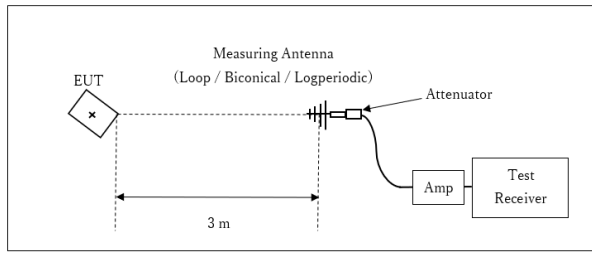

× : Center of turn table

Test Distance: 3 m

1 GHz - 10 GHz

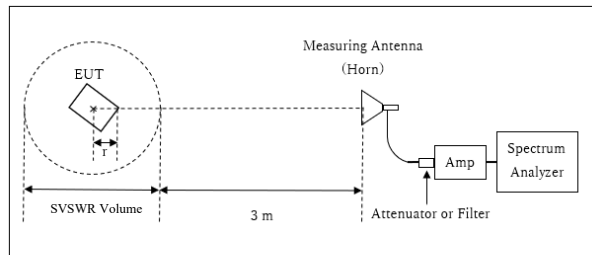

r : Radius of an outer periphery of EUT  
 × : Center of turn table

Distance Factor:  $20 \times \log(3.80 \text{ m} / 3.0 \text{ m}) = 2.06 \text{ dB}$   
 \* Test Distance:  $(3 + \text{SVSWR Volume} / 2) - r = 3.80 \text{ m}$

SVSWR Volume : 2.0 m  
 (SVSWR Volume has been calibrated based on CISPR 16-1-4.)  
 $r = 0.20 \text{ m}$

10 GHz - 26.5 GHz

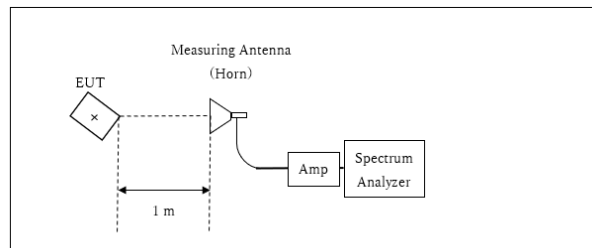

× : Center of turn table

Distance Factor:  $20 \times \log(1.0 \text{ m} / 3.0 \text{ m}) = -9.54 \text{ dB}$   
 \*Test Distance: 1 m

The test was made on EUT at the normal use position.

The test results and limit are rounded off to one decimal place, so some differences might be observed.

**Measurement range** : 30 MHz - 26.5 GHz  
**Test data** : APPENDIX  
**Test result** : Pass

## **SECTION 6: Antenna Terminal Conducted Tests**

### **Test Procedure**

The tests were made with below setting connected to the antenna port.

Test	Span	RBW	VBW	Sweep time	Detector	Trace	Instrument used
6 dB Bandwidth	50 MHz	100 kHz	300 kHz	Auto	Peak	Max Hold	Spectrum Analyzer
99 % Occupied Bandwidth *1)	Enough width to display emission skirts	1 to 5 % of OBW	Three times of RBW	Auto	Peak	Max Hold	Spectrum Analyzer
Maximum Peak Output Power	-	-	-	Auto	Peak/Average *2)	-	Power Meter (Sensor: 160 MHz BW)
Peak Power Density	1.5 times the 6 dB Bandwidth	3 kHz	9.1 kHz	Auto	Peak	Max Hold	Spectrum Analyzer *3)
Conducted Spurious Emission *4) *5)	9 kHz to 150 kHz	200 Hz	620 Hz	Auto	Peak	Max Hold	Spectrum Analyzer
	150 kHz to 30 MHz	10 kHz	30 kHz				

\*1) Peak hold was applied as Worst-case measurement.  
\*2) Reference data  
\*3) Section 11.10.2 Method PKPSD (peak PSD) of "ANSI C63.10-2013".  
\*4) In the frequency range below 30MHz, RBW was narrowed to separate the noise contents.  
Then, wide-band noise near the limit was checked separately, however the noise was not detected as shown in the chart.  
(9 kHz - 150 kHz: RBW = 200 Hz, 150 kHz - 30 MHz: RBW = 10 kHz)  
\*5) The limits in CFR 47, Part 15, Subpart C, paragraph 15.209(a), are identical to those in RSS-Gen section 8.9, Table 6, since the measurements are performed in terms of magnetic field strength and converted to electric field strength levels (as reported in the table) using the free space impedance of 377 Ohms. For example, the measurement at frequency 9 kHz resulted in a level of 45.5 dBuV/m, which is equivalent to  $45.5 - 51.5 = -6.0$  dBuA/m, which has the same margin, 3 dB, to the corresponding RSS-Gen Table 6 limit as it has to 15.209(a) limit.

The test results and limit are rounded off to two decimals place, so some differences might be observed.  
The equipment and cables were not used for factor 0 dB of the data sheets.

**Test data** : APPENDIX  
**Test result** : Pass

**UL Japan, Inc.**

**Shonan EMC Lab.**

1-22-3 Megumigaoka, Hiratsuka-shi, Kanagawa-ken, 259-1220 JAPAN

Telephone : +81 463 50 6400

Facsimile : +81 463 50 6401

**APPENDIX 1: Test data**

**6 dB Bandwidth and 99 % Occupied Bandwidth**

Report No.	13692701S-B-R1	
Test place	Shonan EMC Lab. No.5 Shielded Room	
Date	February 2, 2021	February 10, 2021
Temperature / Humidity	25 deg. C / 47 % RH	22 deg. C / 31 % RH
Engineer	Yosuke Murakami	Yosuke Murakami
Mode	Tx	

Mode	Frequency [MHz]	99% Occupied Bandwidth [kHz]	6dB Bandwidth [MHz]	Limit for 6dB Bandwidth [MHz]
11b	2412	12875.9	7.679	> 0.5000
	2437	12865.7	7.676	> 0.5000
	2462	12880.7	7.674	> 0.5000
11g	2412	16744.7	16.522	> 0.5000
	2437	16713.5	16.516	> 0.5000
	2462	16738.3	16.520	> 0.5000
11n-20 SISO	2412	17981.2	17.725	> 0.5000
	2437	17978.8	17.732	> 0.5000
	2462	17995.9	17.702	> 0.5000
11n-20 MIMO	2412	18025.4	17.768	> 0.5000
	2437	18037.3	17.700	> 0.5000
	2462	18031.3	17.714	> 0.5000

**99 % Occupied Bandwidth**

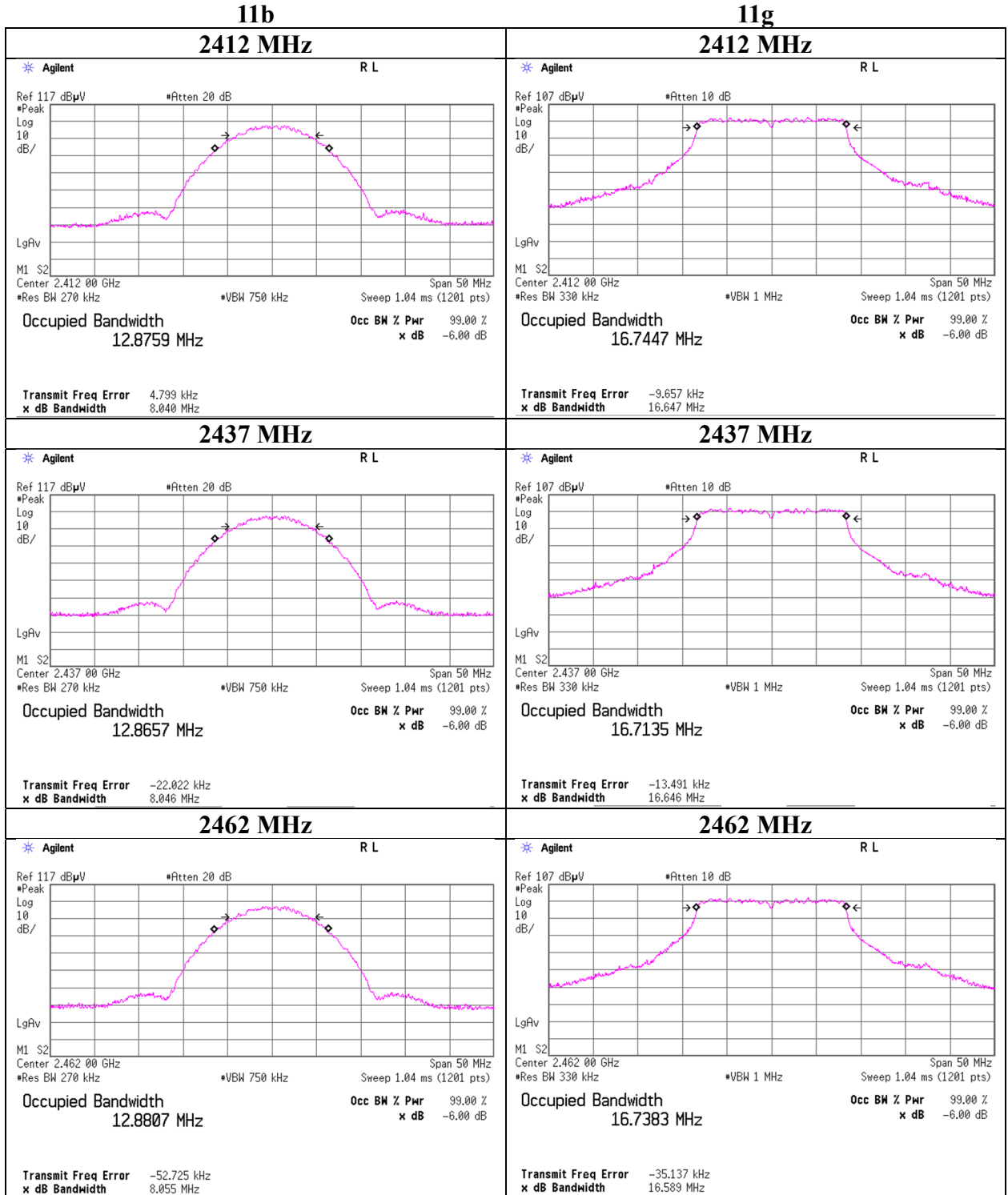

**99 % Occupied Bandwidth**

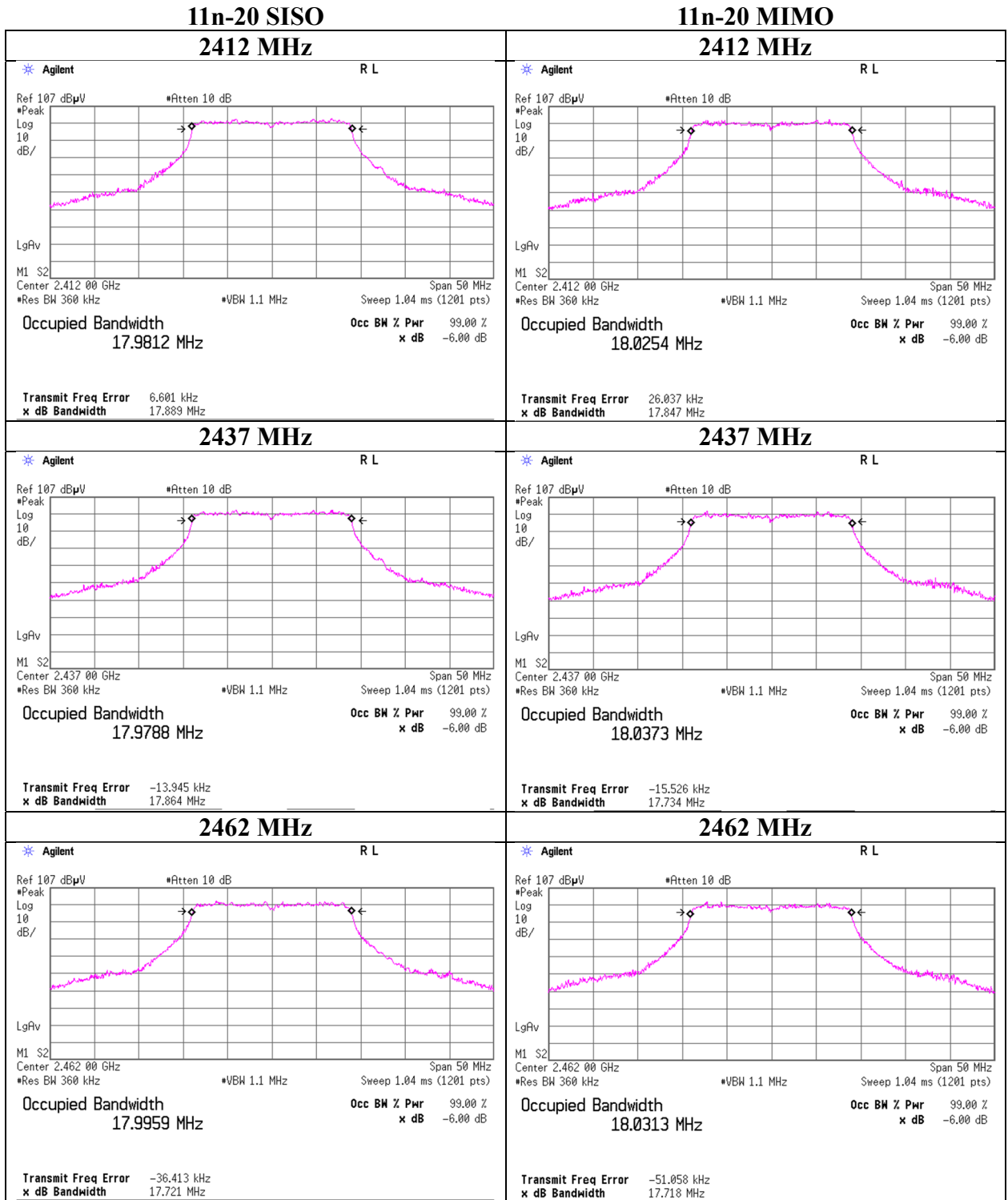

**6 dB Bandwidth**

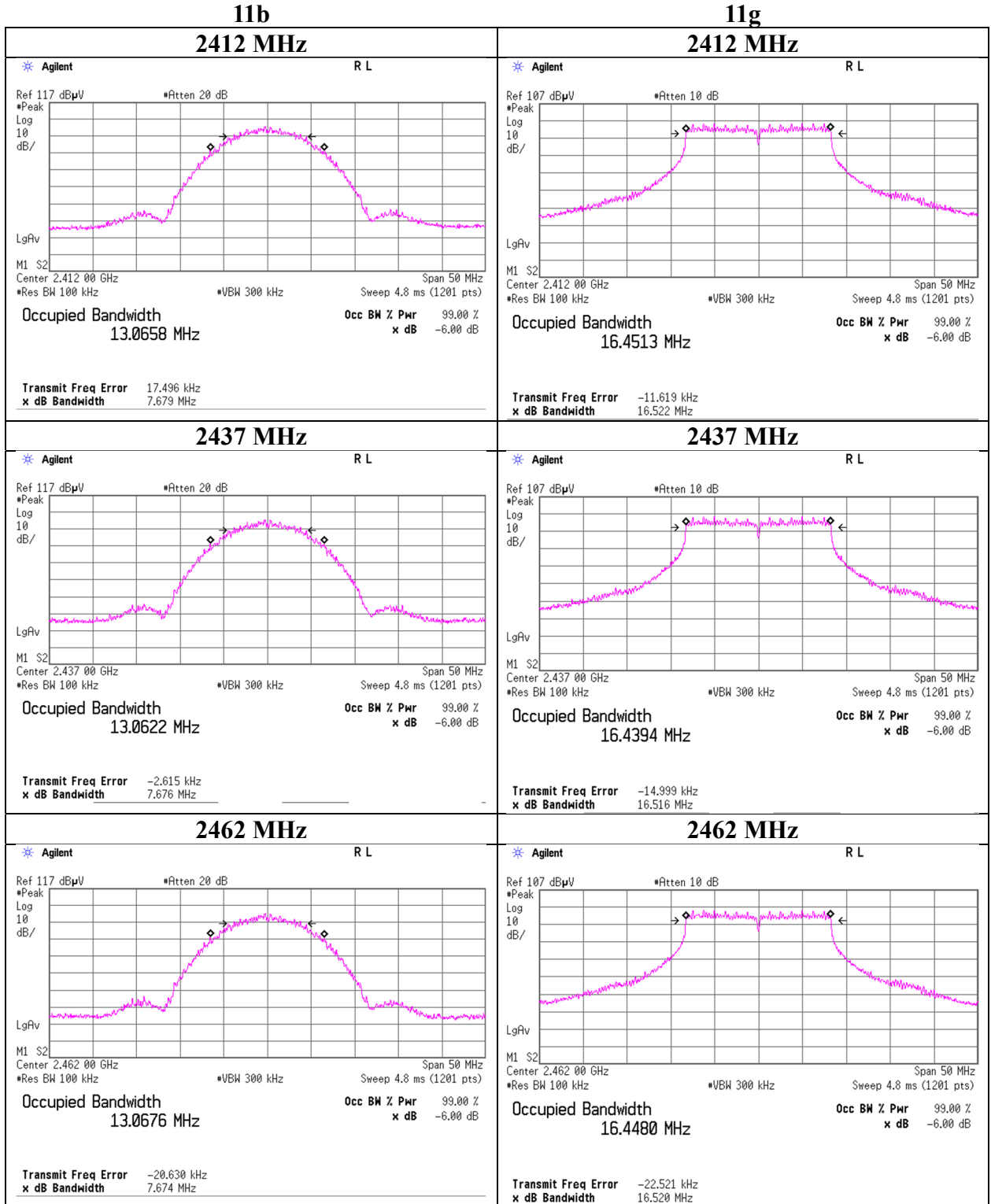

**6 dB Bandwidth**

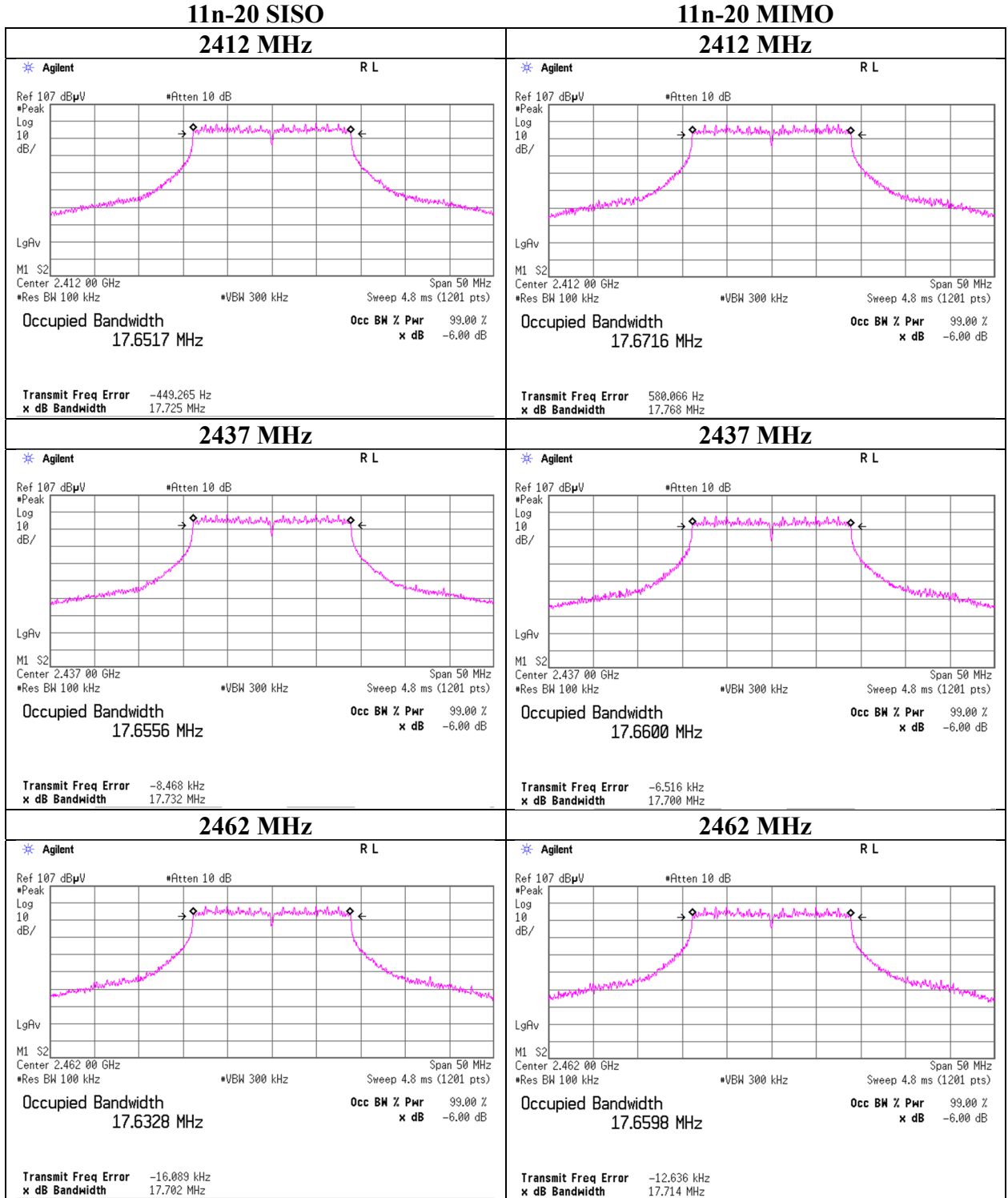

## Maximum Peak Output Power

Report No. 13692701S-B-R1  
Test place Shonan EMC Lab. No.5 Shielded Room  
Date January 30, 2021 February 2, 2021  
Temperature / Humidity 22 deg. C / 37 % RH 25 deg. C / 47 % RH  
Engineer Yosuke Murakami Yosuke Murakami  
Mode Tx 11b

Chain 0				Conducted Power					e.i.r.p. for RSS-247					
Freq. [MHz]	Reading [dBm]	Cable Loss [dB]	Atten. Loss [dB]	Result		Limit		Margin [dB]	Antenna Gain [dBi]	Result		Limit		Margin [dB]
				[dBm]	[mW]	[dBm]	[mW]			[dBm]	[mW]	[dBm]	[mW]	
2412	6.62	1.52	9.87	18.01	63.24	30.00	1000	11.99	2.55	20.56	113.76	36.02	4000	15.46
2437	5.51	1.52	9.87	16.90	48.98	30.00	1000	13.10	2.55	19.45	88.10	36.02	4000	16.57
2462	5.16	1.52	9.87	16.55	45.19	30.00	1000	13.45	2.55	19.10	81.28	36.02	4000	16.92

Sample Calculation:

Result = Reading + Cable Loss (including the cable(s) customer supplied) + Attenuator Loss

e.i.r.p. Result = Conducted Power Result + Antenna Gain

\*The equipment and cables were not used for factor 0 dB of the data sheets.

Chain 0, 2437MHz

Rate	Reading	Remark
[Mbps]	[dBm]	
1	5.11	-
2	5.18	-
5.5	5.17	-
11	5.51	*

\*: Worst Rate

All comparison were carried out on same frequency and measurement factors.



## Maximum Peak Output Power

Report No. 13692701S-B-R1  
Test place Shonan EMC Lab. No.5 Shielded Room  
Date January 30, 2021 February 2, 2021  
Temperature / Humidity 22 deg. C / 37 % RH 25 deg. C / 47 % RH  
Engineer Yosuke Murakami Yosuke Murakami  
Mode Tx 11g

Chain 0				Conducted Power					e.i.r.p. for RSS-247					
Freq. [MHz]	Reading [dBm]	Cable Loss [dB]	Atten. Loss [dB]	Result		Limit		Margin [dB]	Antenna Gain [dBi]	Result		Limit		Margin [dB]
				[dBm]	[mW]	[dBm]	[mW]			[dBm]	[mW]	[dBm]	[mW]	
2412	9.32	1.52	9.87	20.71	117.76	30.00	1000	9.29	2.55	23.26	211.84	36.02	4000	12.76
2437	9.03	1.52	9.87	20.42	110.15	30.00	1000	9.58	2.55	22.97	198.15	36.02	4000	13.05
2462	8.80	1.52	9.87	20.19	104.47	30.00	1000	9.81	2.55	22.74	187.93	36.02	4000	13.28

Sample Calculation:

Result = Reading + Cable Loss (including the cable(s) customer supplied) + Attenuator Loss

e.i.r.p. Result = Conducted Power Result + Antenna Gain

\*The equipment and cables were not used for factor 0 dB of the data sheets.

Chain 0, 2437 MHz

Rate	Reading	Remark
[Mbps]	[dBm]	
6	5.88	-
9	6.26	-
12	6.36	-
18	6.09	-
24	9.03	*
36	8.99	-
48	8.88	-
54	8.91	-

\*: Worst Rate

All comparison were carried out on same frequency and measurement factors.

## Maximum Peak Output Power

Report No. 13692701S-B-R1  
Test place Shonan EMC Lab. No.5 Shielded Room  
Date January 30, 2021 February 2, 2021  
Temperature / Humidity 22 deg. C / 37 % RH 25 deg. C / 47 % RH  
Engineer Yosuke Murakami Yosuke Murakami  
Mode Tx 11n-20 SISO

Chain 0				Conducted Power					e.i.r.p. for RSS-247					
Freq. [MHz]	Reading [dBm]	Cable Loss [dB]	Atten. Loss [dB]	Result		Limit		Margin [dB]	Antenna Gain [dBi]	Result		Limit		Margin [dB]
				[dBm]	[mW]	[dBm]	[mW]			[dBm]	[mW]	[dBm]	[mW]	
2412	9.62	1.52	9.87	21.01	126.18	30.00	1000	8.99	2.55	23.56	226.99	36.02	4000	12.46
2437	9.49	1.52	9.87	20.88	122.46	30.00	1000	9.12	2.55	23.43	220.29	36.02	4000	12.59
2462	8.02	1.52	9.87	19.41	87.30	30.00	1000	10.59	2.55	21.96	157.04	36.02	4000	14.06

Sample Calculation:

Result = Reading + Cable Loss (including the cable(s) customer supplied) + Attenuator Loss

e.i.r.p. Result = Conducted Power Result + Antenna Gain

\*The equipment and cables were not used for factor 0 dB of the data sheets.

Chain 0, 2437 MHz

Rate	Reading	Remark
[MCS]	[dBm]	
0	6.13	-
1	6.33	-
2	6.37	-
3	8.34	-
4	8.76	-
5	8.41	-
6	9.49	*
7	8.35	-

\*: Worst Rate

All comparison were carried out on same frequency and measurement factors.

## Maximum Peak Output Power

Report No.	13692701S-B-R1		
Test place	Shonan EMC Lab. No.5 Shielded Room		
Date	January 30, 2021	February 2, 2021	February 5, 2021
Temperature / Humidity	22 deg. C / 37 % RH	25 deg. C / 47 % RH	26 deg. C / 52 % RH
Engineer	Yosuke Murakami	Yosuke Murakami	Hirosasa Sato
Mode	Tx 11n-20 MIMO		

Chain 0 + Chain 1

Freq. [MHz]	Conducted Power					e.i.r.p.				
	Result		Limit		Margin [dB]	Result		Limit		Margin [dB]
	[dBm]	[mW]	[dBm]	[mW]		[dBm]	[mW]	[dBm]	[mW]	
2412	22.88	193.87	30.00	1000	7.12	23.95	248.58	36.02	4000	12.07
2437	22.82	191.52	30.00	1000	7.18	23.71	234.70	36.02	4000	12.32
2462	22.91	195.45	30.00	1000	7.09	23.72	235.52	36.02	4000	12.30

Sample Calculation:

Result = Chain 0 Result + Chain 1 Result

e.i.r.p. Result = Chain 0 Result (e.i.r.p.) + Chain 1 Result (e.i.r.p.)

Chain 0

Freq. [MHz]	Reading [dBm]	Cable Loss [dB]	Atten. Loss [dB]	Result		Antenna Gain [dBi]	Result (e.i.r.p.)	
				[dBm]	[mW]		[dBm]	[mW]
				2412	8.99		1.52	9.87
2437	8.55	1.52	9.87	19.94	98.63	2.55	22.49	177.42
2462	8.49	1.52	9.87	19.88	97.27	2.55	22.43	174.98

Chain 1

Freq. [MHz]	Reading [dBm]	Cable Loss [dB]	Atten. Loss [dB]	Result		Antenna Gain [dBi]	Result (e.i.r.p.)	
				[dBm]	[mW]		[dBm]	[mW]
				2412	7.88		1.52	9.88
2437	8.28	1.52	9.88	19.68	92.90	-2.10	17.58	57.28
2462	8.54	1.52	9.86	19.92	98.17	-2.10	17.82	60.53

Sample Calculation:

Result = Reading + Cable Loss (including the cable(s) customer supplied) + Attenuator Loss

Result(e.i.r.p.) = Result + Antenna Gain

Worst MCS Check of Conducted Power (2437 MHz)

MCS Number	Chain 0					Chain 1					Total Result Power		Remark
	Reading [dBm]	Cable Loss [dB]	Atten. Loss [dB]	Result		Reading [dBm]	Cable Loss [dB]	Atten. Loss [dB]	Result		[dBm]	[mW]	
				[dBm]	[mW]				[dBm]	[mW]			
8	5.60	1.52	9.87	16.99	50.00	5.92	1.52	9.88	17.32	53.95	20.17	103.95	-
9	5.76	1.52	9.87	17.15	51.88	5.84	1.52	9.88	17.24	52.97	20.21	104.85	-
10	6.11	1.52	9.87	17.50	56.23	5.87	1.52	9.88	17.27	53.33	20.40	109.57	-
11	8.06	1.52	9.87	19.45	88.10	8.44	1.52	9.88	19.84	96.38	22.66	184.49	-
12	8.03	1.52	9.87	19.42	87.50	8.58	1.52	9.88	19.98	99.54	22.72	187.04	-
13	8.11	1.52	9.87	19.50	89.13	8.33	1.52	9.88	19.73	93.97	22.63	183.10	-
14	8.55	1.52	9.87	19.94	98.63	8.28	1.52	9.88	19.68	92.90	22.82	191.52	*
15	8.28	1.52	9.87	19.67	92.68	8.39	1.52	9.88	19.79	95.28	22.74	187.96	-

\*Worst MCS

Sample Calculation:

Each port Result = Reading + Cable Loss (including the cable(s) customer supplied) + Attenuator Loss

Total Result = Chain 0 Result + Chain 1 Result

Worst MCS Check of e.i.r.p. (2437 MHz)

MCS Number	Chain 0					Chain 1					Total Result Power		Remark		
	Reading [dBm]	Cable Loss [dB]	Atten. Loss [dB]	Antenna Gain [dBi]	Result (e.i.r.p.)		Reading [dBm]	Cable Loss [dB]	Atten. Loss [dB]	Antenna Gain [dBi]	Result (e.i.r.p.)			Result Power (e.i.r.p.)	
					[dBm]	[mW]					[dBm]	[mW]		[dBm]	[mW]
8	5.60	1.52	9.87	2.55	19.54	89.95	5.92	1.52	9.88	-2.10	15.22	33.27	20.91	123.22	-
9	5.76	1.52	9.87	2.55	19.70	93.33	5.84	1.52	9.88	-2.10	15.14	32.66	21.00	125.98	-
10	6.11	1.52	9.87	2.55	20.05	101.16	5.87	1.52	9.88	-2.10	15.17	32.89	21.27	134.04	-
11	8.06	1.52	9.87	2.55	22.00	158.49	8.44	1.52	9.88	-2.10	17.74	59.43	23.38	217.92	-
12	8.03	1.52	9.87	2.55	21.97	157.40	8.58	1.52	9.88	-2.10	17.88	61.38	23.40	218.77	-
13	8.11	1.52	9.87	2.55	22.05	160.32	8.33	1.52	9.88	-2.10	17.63	57.94	23.39	218.27	-
14	8.55	1.52	9.87	2.55	22.49	177.42	8.28	1.52	9.88	-2.10	17.58	57.28	23.71	234.70	*
15	8.28	1.52	9.87	2.55	22.22	166.72	8.39	1.52	9.88	-2.10	17.69	58.75	23.53	225.47	-

\*Worst MCS

Sample Calculation:

Each port Result (e.i.r.p.) = Reading + Cable Loss (including the cable(s) customer supplied) + Attenuator Loss + Antenna Gain

Total Result (e.i.r.p.) = Chain 0 Result + Chain 1 Result

**UL Japan, Inc.**

**Shonan EMC Lab.**

1-22-3 Megumigaoka, Hiratsuka-shi, Kanagawa-ken, 259-1220 JAPAN

Telephone : +81 463 50 6400

Facsimile : +81 463 50 6401

**Average Output Power**  
**(Reference data for RF Exposure)**

Report No. 13692701S-B-R1  
Test place Shonan EMC Lab. No.5 Shielded Room  
Date January 30, 2021 February 2, 2021  
Temperature / Humidity 22 deg. C / 37 % RH 25 deg. C / 47 % RH  
Engineer Yosuke Murakami Yosuke Murakami  
Mode Tx 11b

Chain 0 **1 Mbps**

Freq. [MHz]	Reading [dBm]	Cable Loss [dB]	Atten. Loss [dB]	Result (Time average)		Duty factor *1) [dB]	Result (Burst power average)	
				[dBm]	[mW]		[dBm]	[mW]
2412	3.04	1.52	9.87	14.43	27.73	0.00	14.43	27.73
2437	2.57	1.52	9.87	13.96	24.89	0.00	13.96	24.89
2462	2.58	1.52	9.87	13.97	24.95	0.00	13.97	24.95

Sample Calculation:

Result (Time average) = Reading + Cable Loss (including the cable(s) customer supplied) + Attenuator Loss

Result (Burst power average) = Time average + Duty factor

\*1) Power was measured with using the gate function of power meter.

It was means that the intervals during which the transmitter is off or is transmitting at reduced power level is not included in the average. Therefore, there is no need to add duty cycle correction to the result.

**The average output power was measured with the lowest order modulation and lowest data rate configuration in each IEEE 802.11 mode based on KDB 248227 D01.**

**Average Output Power**  
**(Reference data for RF Exposure)**

Report No. 13692701S-B-R1  
Test place Shonan EMC Lab. No.5 Shielded Room  
Date January 30, 2021 February 2, 2021  
Temperature / Humidity 22 deg. C / 37 % RH 25 deg. C / 47 % RH  
Engineer Yosuke Murakami Yosuke Murakami  
Mode Tx 11g

Chain 0 **6 Mbps**

Freq. [MHz]	Reading [dBm]	Cable Loss [dB]	Atten. Loss [dB]	Result (Time average)		Duty factor *1) [dB]	Result (Burst power average)	
				[dBm]	[mW]		[dBm]	[mW]
2412	-0.21	1.52	9.87	11.18	13.12	0.00	11.18	13.12
2437	-0.54	1.52	9.87	10.85	12.16	0.00	10.85	12.16
2462	-0.52	1.52	9.87	10.87	12.22	0.00	10.87	12.22

Sample Calculation:

Result (Time average) = Reading + Cable Loss (including the cable(s) customer supplied) + Attenuator Loss  
Result (Burst power average) = Time average + Duty factor

\*1) Power was measured with using the gate function of power meter.

It was means that the intervals during which the transmitter is off or is transmitting at reduced power level is not included in the average. Therefore, there is no need to add duty cycle correction to the result.

**The average output power was measured with the lowest order modulation and lowest data rate configuration in each IEEE 802.11 mode based on KDB 248227 D01.**

**Average Output Power**  
**(Reference data for RF Exposure)**

Report No. 13692701S-B-R1  
Test place Shonan EMC Lab. No.5 Shielded Room  
Date January 30, 2021 February 2, 2021  
Temperature / Humidity 22 deg. C / 37 % RH 25 deg. C / 47 % RH  
Engineer Yosuke Murakami Yosuke Murakami  
Mode Tx 11n-20 SISO

Chain 0 **MCS 0**

Freq.	Reading	Cable Loss	Atten. Loss	Result (Time average)		Duty factor *1)	Result (Burst power average)	
				[dBm]	[mW]		[dBm]	[mW]
[MHz]	[dBm]	[dB]	[dB]	[dBm]	[mW]	[dB]	[dBm]	[mW]
2412	-0.46	1.52	9.87	10.93	12.39	0.00	10.93	12.39
2437	-0.73	1.52	9.87	10.66	11.64	0.00	10.66	11.64
2462	-0.82	1.52	9.87	10.57	11.40	0.00	10.57	11.40

Sample Calculation:

Result (Time average) = Reading + Cable Loss (including the cable(s) customer supplied) + Attenuator Loss  
Result (Burst power average) = Time average + Duty factor

\*1) Power was measured with using the gate function of power meter.

It was means that the intervals during which the transmitter is off or is transmitting at reduced power level is not included in the average. Therefore, there is no need to add duty cycle correction to the result.

**The average output power was measured with the lowest order modulation and lowest data rate configuration in each IEEE 802.11 mode based on KDB 248227 D01.**

**Average Output Power**  
**(Reference data for RF Exposure)**

Report No. 13692701S-B-R1  
Test place Shonan EMC Lab. No.5 Shielded Room  
Date January 30, 2021 February 2, 2021 February 5, 2021  
Temperature / Humidity 22 deg. C / 37 % RH 25 deg. C / 47 % RH 26 deg. C / 52 % RH  
Engineer Yosuke Murakami Yosuke Murakami Hiromasa Sato  
Mode Tx 11n-20 MIMO

Chain 0 + Chain 1

Freq. [MHz]	Chain 0 Result [mW]	Chain 1 Result [mW]	Result (Burst Power Average)	
			[dBm]	[mW]
2412	11.91	10.40	13.49	22.31
2437	10.67	11.64	13.48	22.31
2462	10.72	12.22	13.60	22.93

Sample Calculation:

Result = Chain 0 + Chain 1

Chain 0 MCS 8

Freq. [MHz]	Reading [dBm]	Cable Loss [dB]	Atten. Loss [dB]	Result (Time average)		Duty factor *1) [dB]	Result (Burst power average)	
				[dBm]	[mW]		[dBm]	[mW]
2412	-0.63	1.52	9.87	10.76	11.91	0.00	10.76	11.91
2437	-1.11	1.52	9.87	10.28	10.67	0.00	10.28	10.67
2462	-1.09	1.52	9.87	10.30	10.72	0.00	10.30	10.72

Chain 1 MCS 8

Freq. [MHz]	Reading [dBm]	Cable Loss [dB]	Atten. Loss [dB]	Result (Time average)		Duty factor *1) [dB]	Result (Burst power average)	
				[dBm]	[mW]		[dBm]	[mW]
2412	-1.23	1.52	9.88	10.17	10.40	0.00	10.17	10.40
2437	-0.74	1.52	9.88	10.66	11.64	0.00	10.66	11.64
2462	-0.51	1.52	9.86	10.87	12.22	0.00	10.87	12.22

Sample Calculation:

Result (Time average) = Reading + Cable Loss (including the cable(s) customer supplied) + Attenuator Loss

Result (Burst power average) = Time average + Duty factor

\*1) Power was measured with using the gate function of power meter.

It was means that the intervals during which the transmitter is off or is transmitting at reduced power level is not included in the average. Therefore, there is no need to add duty cycle correction to the result.

**The average output power was measured with the lowest order modulation and lowest data rate configuration in each IEEE 802.11 mode based on KDB 248227 D01.**

**UL Japan, Inc.**

**Shonan EMC Lab.**

1-22-3 Megumigaoka, Hiratsuka-shi, Kanagawa-ken, 259-1220 JAPAN

Telephone : +81 463 50 6400

Facsimile : +81 463 50 6401

## Burst rate confirmation

Report No.	13692701S-B-R1
Test place	Shonan EMC Lab. No.5 Shielded Room
Date	January 30, 2021
Temperature / Humidity	22 deg. C / 37 % RH
Engineer	Yosuke Murakami
Mode	Tx

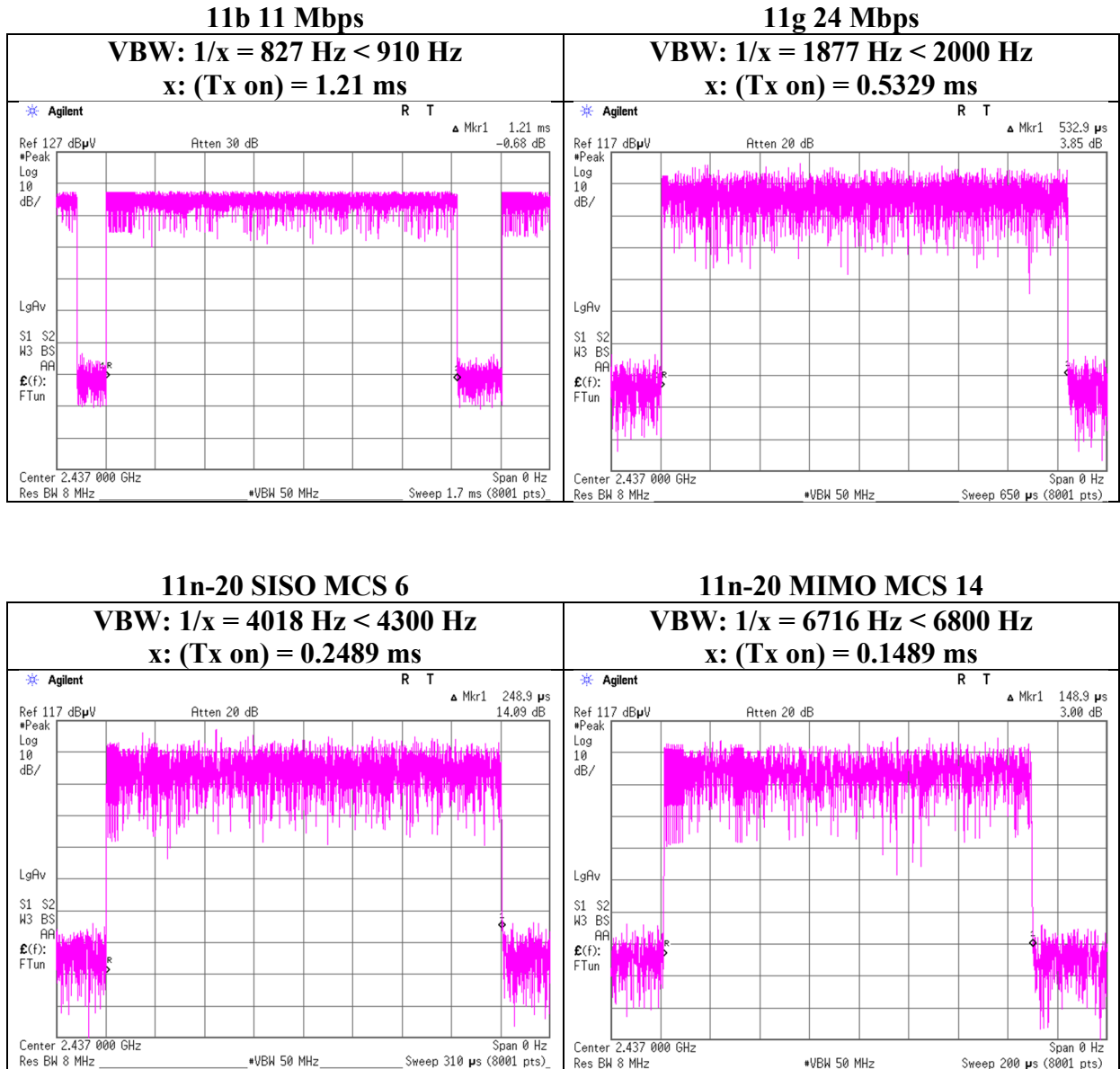

\* Since the burst rate is not different between the channels, the data has been obtained on the representative channel.



## Radiated Spurious Emission

Report No. 13692701S-B-R1  
Test place Shonan EMC Lab.  
Semi Anechoic Chamber 2  
Date February 3, 2021 February 5, 2021  
Temperature / Humidity 22 deg.C, 38 %RH 24 deg.C, 33 %RH  
Engineer Takahiro Suzuki Hiromasa Sato  
( 1 GHz -10 GHz ) ( 10 GHz -26.5 GHz )  
Mode Tx 11b 2412 MHz

(\* PK: Peak, AV: Average, QP: Quasi-Peak)

Polarity	Frequency [MHz]	Detector	Reading [dBuV]	Ant.Fac. [dB/m]	Loss [dB]	Gain [dB]	Distance Factor [dB]	Result [dBuV/m]	Limit [dBuV/m]	Margin [dB]	Height [cm]	Angle [deg]	Remark
Hori.	2390.000	PK	48.39	28.56	14.13	38.68	2.06	54.46	73.9	19.4	187	58	-
Hori.	4824.000	PK	46.35	31.60	6.59	38.54	2.06	48.06	73.9	25.8	150	0	floor noise
Hori.	7236.000	PK	46.81	37.65	8.02	39.17	2.06	55.37	73.9	18.5	150	0	floor noise
Hori.	9648.000	PK	47.59	38.83	9.25	39.67	2.06	58.06	73.9	15.8	143	153	-
Hori.	2390.000	AV	35.12	28.56	14.13	38.68	2.06	41.19	53.9	12.7	187	58	VBW:910 Hz
Hori.	4824.000	AV	35.03	31.60	6.59	38.54	2.06	36.74	53.9	17.1	150	0	VBW:910 Hz, floor noise
Hori.	7236.000	AV	36.00	37.65	8.02	39.17	2.06	44.56	53.9	9.3	150	0	VBW:910 Hz, floor noise
Hori.	9648.000	AV	36.31	38.83	9.25	39.67	2.06	46.78	53.9	7.1	143	153	VBW:910 Hz
Vert.	2390.000	PK	48.62	28.56	14.13	38.68	2.06	54.69	73.9	19.2	140	277	-
Vert.	4824.000	PK	46.23	31.60	6.59	38.54	2.06	47.94	73.9	25.9	150	0	floor noise
Vert.	7236.000	PK	47.35	37.65	8.02	39.17	2.06	55.91	73.9	17.9	150	0	floor noise
Vert.	9648.000	PK	47.65	38.83	9.25	39.67	2.06	58.12	73.9	15.7	100	143	-
Vert.	2390.000	AV	34.70	28.56	14.13	38.68	2.06	40.77	53.9	13.1	140	277	VBW:910 Hz
Vert.	4824.000	AV	34.82	31.60	6.59	38.54	2.06	36.53	53.9	17.3	150	0	VBW:910 Hz, floor noise
Vert.	7236.000	AV	35.77	37.65	8.02	39.17	2.06	44.33	53.9	9.5	150	0	VBW:910 Hz, floor noise
Vert.	9648.000	AV	35.66	38.83	9.25	39.67	2.06	46.13	53.9	7.7	100	143	VBW:910 Hz

Result = Reading + Ant.Fac. + Loss (Cable+(Attenuator or Filter)(below 18 GHz)) - Gain(Amplifier) + Distance factor

Distance factor : 1 GHz - 10 GHz : 20log(3.80 m / 3.0 m) = 2.06 dB

10 GHz - 40 GHz : 20log(1.0 m / 3.0 m) = -9.54 dB

### 20 dBc Data Sheet (RBW 100 kHz, VBW 300 kHz)

Polarity	Frequency [MHz]	Detector	Reading [dBuV]	Ant.Fac. [dB/m]	Loss [dB]	Gain [dB]	Distance Factor [dB]	Result [dBuV/m]	Limit [dBuV/m]	Margin [dB]	Remark
Hori.	2412.000	PK	92.29	28.52	14.15	38.66	2.06	98.36	-	-	Carrier
Hori.	2400.000	PK	38.95	28.54	14.15	38.67	2.06	45.03	78.3	33.2	-
Vert.	2412.000	PK	90.74	28.52	14.15	38.66	2.06	96.81	-	-	Carrier
Vert.	2400.000	PK	38.04	28.54	14.15	38.67	2.06	44.12	76.8	32.6	-

Result = Reading + Ant.Fac. + Loss (Cable+(Attenuator or Filter)(below 18 GHz)) - Gain(Amplifier) + Distance factor

Distance factor : 1 GHz - 10 GHz : 20log(3.80 m / 3.0 m) = 2.06 dB

10 GHz - 40 GHz : 20log(1.0 m / 3.0 m) = -9.54 dB

**Radiated Spurious Emission  
(Reference Plot for band-edge)**

Report No. 13692701S-B-R1  
Test place Shonan EMC Lab.  
Semi Anechoic Chamber 2  
Date February 3, 2021  
Temperature / Humidity 22 deg.C, 38 %RH  
Engineer Takahiro Suzuki  
Mode Tx 11b 2412 MHz

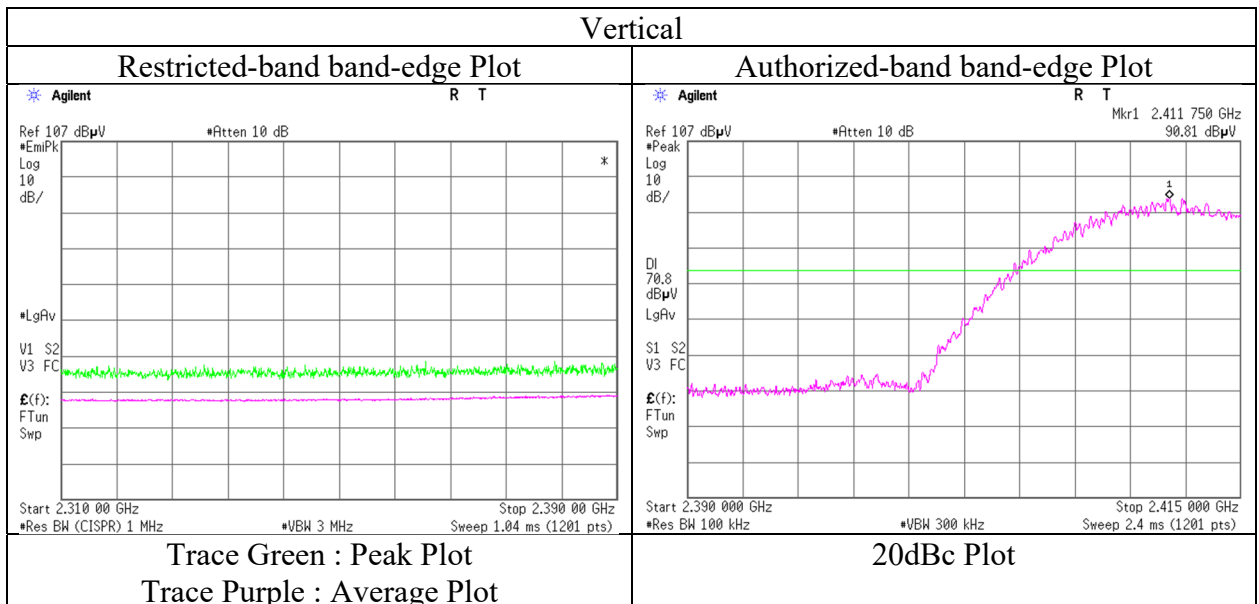
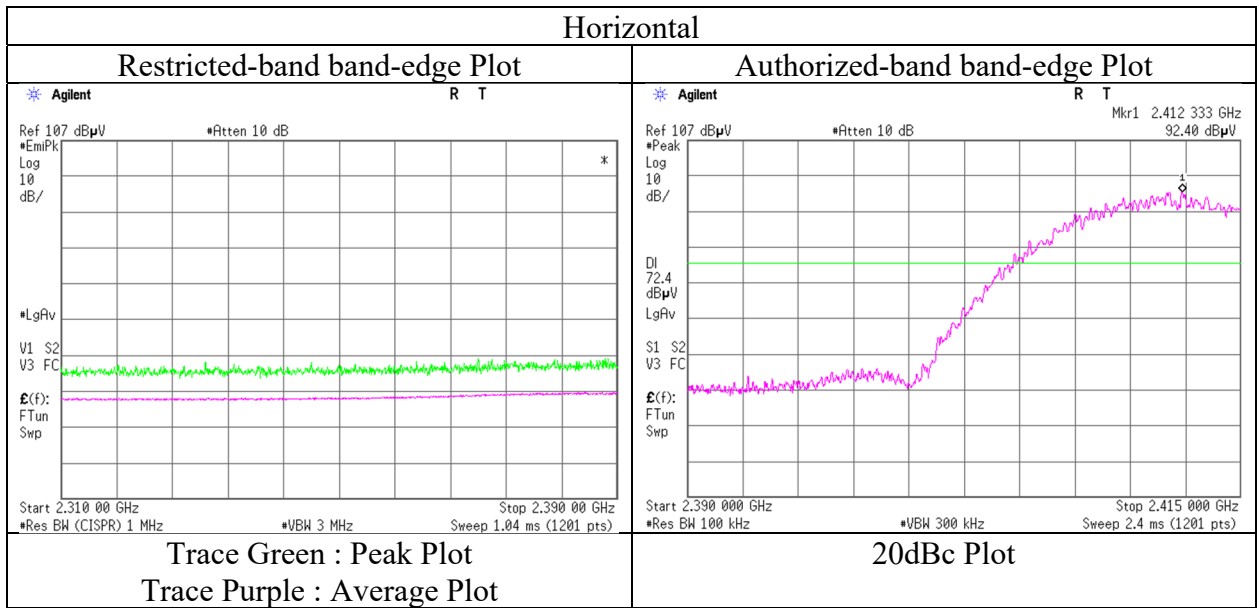

\* The measurement was conducted for a sufficiently long enough time to detect any possible spurious emissions. Final result of restricted band edge was shown in tabular data.

## Radiated Spurious Emission

Report No. 13692701S-B-R1  
Test place Shonan EMC Lab.  
Semi Anechoic Chamber 2 2 2  
Date February 3, 2021 February 4, 2021 February 5, 2021  
Temperature / Humidity 22 deg.C, 38 %RH 21 deg.C, 36 %RH 24 deg.C, 33 %RH  
Engineer Takahiro Suzuki Takahiro Suzuki Hiromasa Sato  
( 1 GHz -2.8 GHz ) ( 2.8 GHz -10 GHz ) ( 10 GHz -26.5 GHz )  
Mode Tx 11b 2437 MHz

(\* PK: Peak, AV: Average, QP: Quasi-Peak)

Polarity	Frequency [MHz]	Detector	Reading [dBuV]	Ant.Fac. [dB/m]	Loss [dB]	Gain [dB]	Distance Factor [dB]	Result [dBuV/m]	Limit [dBuV/m]	Margin [dB]	Height [cm]	Angle [deg]	Remark
Hori.	4874.000	PK	45.40	31.58	6.61	38.54	2.06	47.11	73.9	26.7	150	0	floor noise
Hori.	7311.000	PK	46.42	37.71	8.04	39.27	2.06	54.96	73.9	18.9	150	0	floor noise
Hori.	9748.000	PK	49.24	39.09	9.29	39.62	2.06	60.06	73.9	13.8	100	142	-
Hori.	4874.000	AV	33.67	31.58	6.61	38.54	2.06	35.38	53.9	18.5	150	0	VBW:910 Hz, floor noise
Hori.	7311.000	AV	34.36	37.71	8.04	39.27	2.06	42.90	53.9	11.0	150	0	VBW:910 Hz, floor noise
Hori.	9748.000	AV	36.74	39.09	9.29	39.62	2.06	47.56	53.9	6.3	100	142	VBW:910 Hz
Vert.	4874.000	PK	45.15	31.58	6.61	38.54	2.06	46.86	73.9	27.0	150	0	floor noise
Vert.	7311.000	PK	46.54	37.71	8.04	39.27	2.06	55.08	73.9	18.8	150	0	floor noise
Vert.	9748.000	PK	48.75	39.09	9.29	39.62	2.06	59.57	73.9	14.3	126	146	-
Vert.	4874.000	AV	33.28	31.58	6.61	38.54	2.06	34.99	53.9	18.9	150	0	VBW:910 Hz, floor noise
Vert.	7311.000	AV	34.38	37.71	8.04	39.27	2.06	42.92	53.9	10.9	150	0	VBW:910 Hz, floor noise
Vert.	9748.000	AV	36.02	39.09	9.29	39.62	2.06	46.84	53.9	7.0	126	146	VBW:910 Hz

Result = Reading + Ant.Fac. + Loss (Cable+(Attenuator or Filter)(below 18 GHz)) - Gain(Amplifier) + Distance factor

Distance factor : 1 GHz - 10 GHz :  $20\log(3.80\text{ m} / 3.0\text{ m}) = 2.06\text{ dB}$

10 GHz - 40 GHz :  $20\log(1.0\text{ m} / 3.0\text{ m}) = -9.54\text{ dB}$

**UL Japan, Inc.**

**Shonan EMC Lab.**

1-22-3 Megumigaoka, Hiratsuka-shi, Kanagawa-ken, 259-1220 JAPAN

Telephone : +81 463 50 6400

Facsimile : +81 463 50 6401

## Radiated Spurious Emission

Report No.	13692701S-B-R1		
Test place	Shonan EMC Lab.		
Semi Anechoic Chamber	2	2	2
Date	February 3, 2021	February 4, 2021	February 5, 2021
Temperature / Humidity	22 deg.C, 38 %RH	21 deg.C, 36 %RH	24 deg.C, 33 %RH
Engineer	Takahiro Suzuki	Takahiro Suzuki	Hiromasa Sato
	( 1 GHz -2.8 GHz )	( 2.8 GHz -10 GHz )	( 10 GHz -26.5 GHz )
Mode	Tx 11b 2462 MHz		

(\* PK: Peak, AV: Average, QP: Quasi-Peak)

Polarity	Frequency [MHz]	Detector	Reading [dBuV]	Ant.Fac. [dB/m]	Loss [dB]	Gain [dB]	Distance Factor [dB]	Result [dBuV/m]	Limit [dBuV/m]	Margin [dB]	Height [cm]	Angle [deg]	Remark
Hori.	2483.500	PK	48.18	28.40	14.23	38.62	2.06	54.25	73.9	19.6	136	258	-
Hori.	4924.000	PK	45.91	31.63	6.65	38.54	2.06	47.71	73.9	26.1	150	0	floor noise
Hori.	7386.000	PK	46.23	37.79	8.10	39.36	2.06	54.82	73.9	19.0	150	0	floor noise
Hori.	9848.000	PK	48.97	39.24	9.33	39.56	2.06	60.04	73.9	13.8	110	152	-
Hori.	2483.500	AV	35.30	28.40	14.23	38.62	2.06	41.37	53.9	12.5	136	258	VBW:910 Hz
Hori.	4924.000	AV	33.07	31.63	6.65	38.54	2.06	34.87	53.9	19.0	150	0	VBW:910 Hz floor noise
Hori.	7386.000	AV	33.75	37.79	8.10	39.36	2.06	42.34	53.9	11.5	150	0	VBW:910 Hz floor noise
Hori.	9848.000	AV	36.16	39.24	9.33	39.56	2.06	47.23	53.9	6.6	110	152	VBW:910 Hz
Vert.	2483.500	PK	47.50	28.40	14.23	38.62	2.06	53.57	73.9	20.3	138	24	-
Vert.	4924.000	PK	46.94	31.63	6.65	38.54	2.06	48.74	73.9	25.1	150	0	floor noise
Vert.	7386.000	PK	47.35	37.79	8.10	39.36	2.06	55.94	73.9	17.9	150	0	floor noise
Vert.	9848.000	PK	46.25	39.24	9.33	39.56	2.06	57.32	73.9	16.5	111	142	-
Vert.	2483.500	AV	33.76	28.40	14.23	38.62	2.06	39.83	53.9	14.0	138	24	VBW:910 Hz
Vert.	4924.000	AV	33.47	31.63	6.65	38.54	2.06	35.27	53.9	18.6	150	0	VBW:910 Hz floor noise
Vert.	7386.000	AV	34.19	37.79	8.10	39.36	2.06	42.78	53.9	11.1	150	0	VBW:910 Hz floor noise
Vert.	9848.000	AV	35.25	39.24	9.33	39.56	2.06	46.32	53.9	7.5	111	142	VBW:910 Hz

Result = Reading + Ant.Fac. + Loss (Cable+(Attenuator or Filter)(below 18 GHz)) - Gain(Amplifier) + Distance factor

Distance factor : 1 GHz - 10 GHz : 20log(3.80 m / 3.0 m) = 2.06 dB

10 GHz - 40 GHz : 20log(1.0 m / 3.0 m) = -9.54 dB

**UL Japan, Inc.**

**Shonan EMC Lab.**

1-22-3 Megumigaoka, Hiratsuka-shi, Kanagawa-ken, 259-1220 JAPAN

Telephone : +81 463 50 6400

Facsimile : +81 463 50 6401

**Radiated Spurious Emission**  
**(Reference Plot for band-edge)**

Report No. 13692701S-B-R1  
Test place Shonan EMC Lab.  
Semi Anechoic Chamber 2  
Date February 3, 2021  
Temperature / Humidity 22 deg.C, 38 %RH  
Engineer Takahiro Suzuki  
Mode Tx 11b 2462 MHz

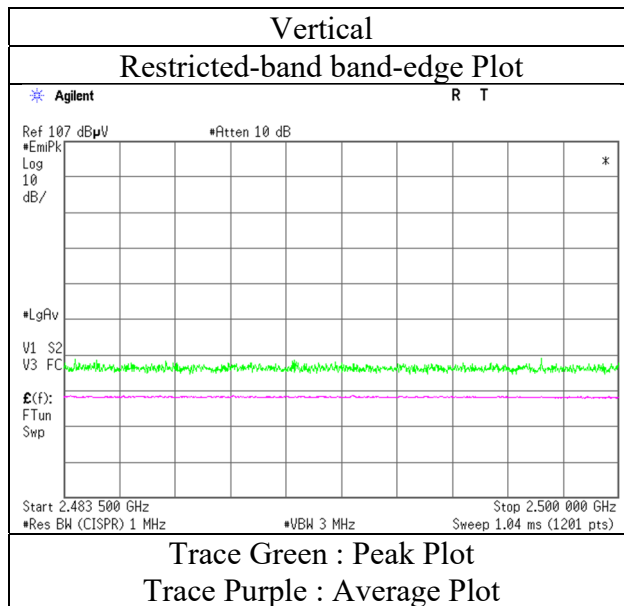
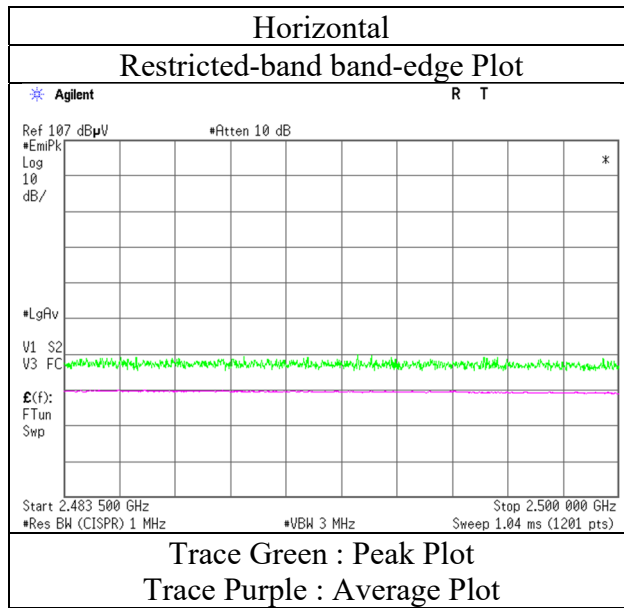

\* The measurement was conducted for a sufficiently long enough time to detect any possible spurious emissions. Final result of restricted band edge was shown in tabular data.

## Radiated Spurious Emission

Report No. 13692701S-B-R1  
Test place Shonan EMC Lab.  
Semi Anechoic Chamber 2 2 2  
Date February 3, 2021 February 4, 2021 February 5, 2021  
Temperature / Humidity 22 deg.C, 38 %RH 21 deg.C, 36 %RH 24 deg.C, 33 %RH  
Engineer Takahiro Suzuki Takahiro Suzuki Hiromasa Sato  
( 1 GHz -2.8 GHz ) ( 2.8 GHz -10 GHz ) ( 10 GHz -26.5 GHz )  
Mode Tx 11g 2412 MHz

(\* PK: Peak, AV: Average, QP: Quasi-Peak)

Polarity	Frequency [MHz]	Detector	Reading [dBuV]	Ant.Fac. [dB/m]	Loss [dB]	Gain [dB]	Distance Factor [dB]	Result [dBuV/m]	Limit [dBuV/m]	Margin [dB]	Height [cm]	Angle [deg]	Remark
Hori.	2390.000	PK	49.30	28.56	14.13	38.68	2.06	55.37	73.9	18.5	173	95	-
Hori.	4824.000	PK	46.40	31.60	6.59	38.54	2.06	48.11	73.9	25.7	150	0	floor noise
Hori.	7236.000	PK	46.69	37.65	8.02	39.17	2.06	55.25	73.9	18.6	150	0	floor noise
Hori.	9648.000	PK	48.91	38.83	9.25	39.67	2.06	59.38	73.9	14.5	140	166	-
Hori.	2390.000	AV	36.36	28.56	14.13	38.68	2.06	42.43	53.9	11.4	173	95	VBW:2 kHz
Hori.	4824.000	AV	34.33	31.60	6.59	38.54	2.06	36.04	53.9	17.8	150	0	VBW:2 kHz, floor noise
Hori.	7236.000	AV	34.84	37.65	8.02	39.17	2.06	43.40	53.9	10.5	150	0	VBW:2 kHz, floor noise
Hori.	9648.000	AV	36.45	38.83	9.25	39.67	2.06	46.92	53.9	6.9	140	166	VBW:2 kHz
Vert.	2390.000	PK	48.26	28.56	14.13	38.68	2.06	54.33	73.9	19.5	137	276	-
Vert.	4824.000	PK	46.19	31.60	6.59	38.54	2.06	47.90	73.9	26.0	150	0	floor noise
Vert.	7236.000	PK	47.21	37.65	8.02	39.17	2.06	55.77	73.9	18.1	150	0	floor noise
Vert.	9648.000	PK	48.43	38.83	9.25	39.67	2.06	58.90	73.9	15.0	189	157	-
Vert.	2390.000	AV	35.51	28.56	14.13	38.68	2.06	41.58	53.9	12.3	137	276	VBW:2 kHz
Vert.	4824.000	AV	34.35	31.60	6.59	38.54	2.06	36.06	53.9	17.8	150	0	VBW:2 kHz, floor noise
Vert.	7236.000	AV	34.96	37.65	8.02	39.17	2.06	43.52	53.9	10.3	150	0	VBW:2 kHz, floor noise
Vert.	9648.000	AV	36.63	38.83	9.25	39.67	2.06	47.10	53.9	6.8	189	157	VBW:2 kHz

Result = Reading + Ant.Fac. + Loss (Cable+(Attenuator or Filter)(below 18 GHz)) - Gain(Amplifier) + Distance factor

Distance factor : 1 GHz - 10 GHz : 20log(3.80 m / 3.0 m) = 2.06 dB  
10 GHz - 40 GHz : 20log(1.0 m / 3.0 m) = -9.54 dB

### 20 dBc Data Sheet (RBW 100 kHz, VBW 300 kHz)

Polarity	Frequency [MHz]	Detector	Reading [dBuV]	Ant.Fac. [dB/m]	Loss [dB]	Gain [dB]	Distance Factor [dB]	Result [dBuV/m]	Limit [dBuV/m]	Margin [dB]	Remark
Hori.	2412.000	PK	85.34	28.52	14.15	38.66	2.06	91.41	-	-	Carrier
Hori.	2400.000	PK	50.63	28.54	14.15	38.67	2.06	56.71	71.4	14.6	-
Vert.	2412.000	PK	83.09	28.52	14.15	38.66	2.06	89.16	-	-	Carrier
Vert.	2400.000	PK	47.66	28.54	14.15	38.67	2.06	53.74	69.1	15.3	-

Result = Reading + Ant.Fac. + Loss (Cable+(Attenuator or Filter)(below 18 GHz)) - Gain(Amplifier) + Distance factor

Distance factor : 1 GHz - 10 GHz : 20log(3.80 m / 3.0 m) = 2.06 dB  
10 GHz - 40 GHz : 20log(1.0 m / 3.0 m) = -9.54 dB

**UL Japan, Inc.**

**Shonan EMC Lab.**

1-22-3 Megumigaoka, Hiratsuka-shi, Kanagawa-ken, 259-1220 JAPAN

Telephone : +81 463 50 6400

Facsimile : +81 463 50 6401

## Radiated Spurious Emission (Reference Plot for band-edge)

Report No.	13692701S-B-R1
Test place	Shonan EMC Lab.
Semi Anechoic Chamber	2
Date	February 3, 2021
Temperature / Humidity	22 deg.C, 38 %RH
Engineer	Takahiro Suzuki
Mode	Tx 11g 2412 MHz

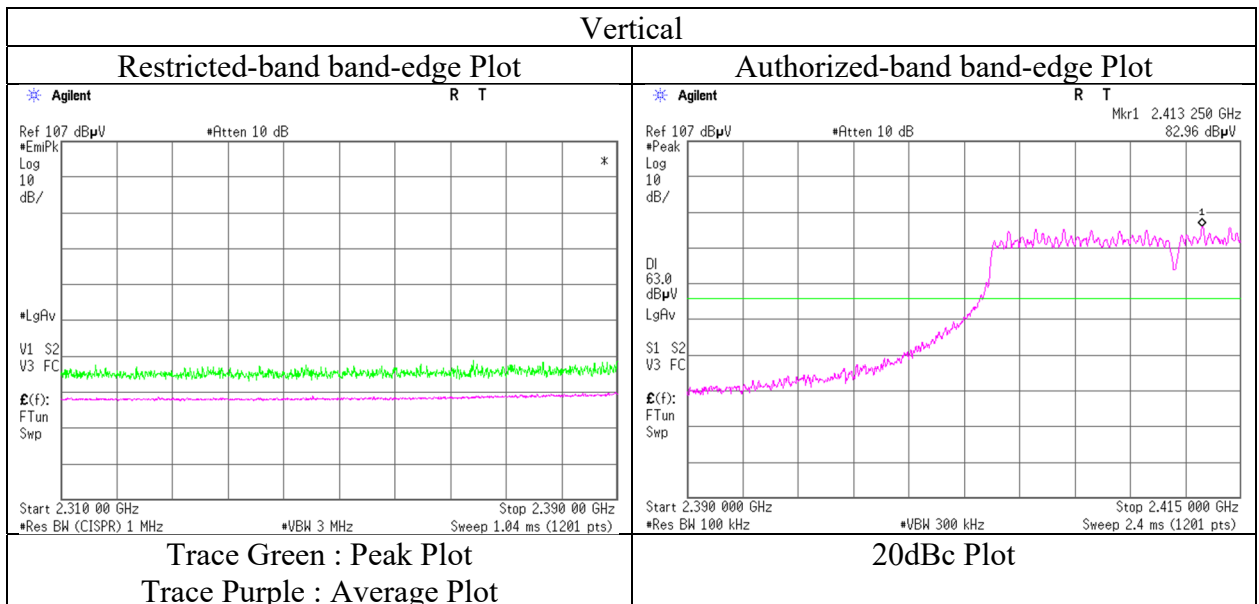
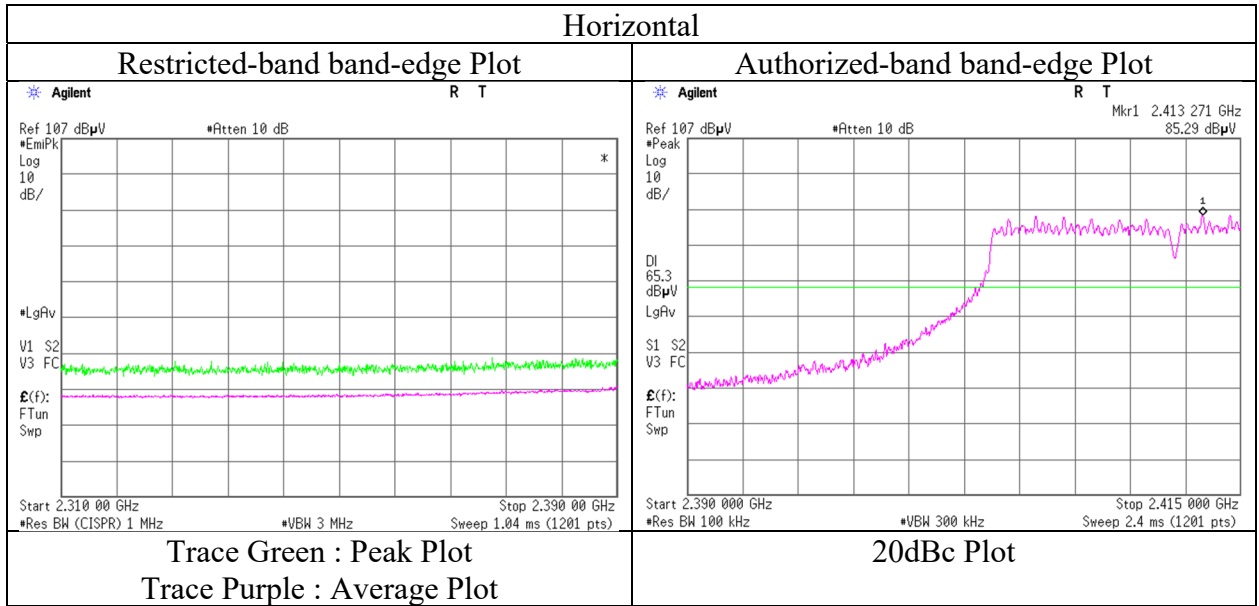

\* The measurement was conducted for a sufficiently long enough time to detect any possible spurious emissions. Final result of restricted band edge was shown in tabular data.

## Radiated Spurious Emission

Report No.	13692701S-B-R1		
Test place	Shonan EMC Lab.		
Semi Anechoic Chamber	2	2	2
Date	February 3, 2021	February 4, 2021	February 5, 2021
Temperature / Humidity	22 deg.C, 38 %RH	21 deg.C, 36 %RH	24 deg.C, 33 %RH
Engineer	Takahiro Suzuki	Takahiro Suzuki	Hiromasa Sato
	( 1 GHz -2.8 GHz )	( 2.8 GHz -10 GHz )	( 10 GHz -26.5 GHz )
Mode	Tx 11g 2437 MHz		

(\* PK: Peak, AV: Average, QP: Quasi-Peak)

Polarity	Frequency [MHz]	Detector	Reading [dBuV]	Ant.Fac. [dB/m]	Loss [dB]	Gain [dB]	Distance Factor [dB]	Result [dBuV/m]	Limit [dBuV/m]	Margin [dB]	Height [cm]	Angle [deg]	Remark
Hori.	4874.000	PK	45.09	31.58	6.61	38.54	2.06	46.80	73.9	27.1	150	0	floor noise
Hori.	7311.000	PK	46.67	37.71	8.04	39.27	2.06	55.21	73.9	18.6	150	0	floor noise
Hori.	9748.000	PK	49.11	39.09	9.29	39.62	2.06	59.93	73.9	13.9	128	156	-
Hori.	4874.000	AV	33.87	31.58	6.61	38.54	2.06	35.58	53.9	18.3	150	0	VBW:2 kHz, floor noise
Hori.	7311.000	AV	34.59	37.71	8.04	39.27	2.06	43.13	53.9	10.7	150	0	VBW:2 kHz, floor noise
Hori.	9748.000	AV	36.63	39.09	9.29	39.62	2.06	47.45	53.9	6.4	128	156	VBW:2 kHz
Vert.	4874.000	PK	45.22	31.58	6.61	38.54	2.06	46.93	73.9	26.9	150	0	floor noise
Vert.	7311.000	PK	46.39	37.71	8.04	39.27	2.06	54.93	73.9	18.9	150	0	floor noise
Vert.	9748.000	PK	48.17	39.09	9.29	39.62	2.06	58.99	73.9	14.9	148	156	-
Vert.	4874.000	AV	33.91	31.58	6.61	38.54	2.06	35.62	53.9	18.2	150	0	VBW:2 kHz, floor noise
Vert.	7311.000	AV	34.58	37.71	8.04	39.27	2.06	43.12	53.9	10.7	150	0	VBW:2 kHz, floor noise
Vert.	9748.000	AV	36.14	39.09	9.29	39.62	2.06	46.96	53.9	6.9	148	156	VBW:2 kHz

Result = Reading + Ant.Fac. + Loss (Cable+(Attenuator or Filter)(below 18 GHz)) - Gain(Amplifier) + Distance factor

Distance factor : 1 GHz - 10 GHz :  $20\log(3.80\text{ m} / 3.0\text{ m}) = 2.06\text{ dB}$

10 GHz - 40 GHz :  $20\log(1.0\text{ m} / 3.0\text{ m}) = -9.54\text{ dB}$



## Radiated Spurious Emission

Report No.	13692701S-B-R1		
Test place	Shonan EMC Lab.		
Semi Anechoic Chamber	2	2	2
Date	February 3, 2021	February 4, 2021	February 5, 2021
Temperature / Humidity	22 deg.C, 38 %RH	21 deg.C, 36 %RH	24 deg.C, 33 %RH
Engineer	Takahiro Suzuki	Takahiro Suzuki	Hiromasa Sato
	( 1 GHz -2.8 GHz )	( 2.8 GHz -10 GHz )	( 10 GHz -26.5 GHz )
Mode	Tx 11g 2462 MHz		

(\* PK: Peak, AV: Average, QP: Quasi-Peak)

Polarity	Frequency [MHz]	Detector	Reading [dBuV]	Ant.Fac. [dB/m]	Loss [dB]	Gain [dB]	Distance Factor [dB]	Result [dBuV/m]	Limit [dBuV/m]	Margin [dB]	Height [cm]	Angle [deg]	Remark
Hori.	2483.500	PK	55.08	28.40	14.23	38.62	2.06	61.15	73.9	12.7	100	264	-
Hori.	4924.000	PK	46.88	31.63	6.65	38.54	2.06	48.68	73.9	25.2	150	0	floor noise
Hori.	7386.000	PK	47.39	37.79	8.10	39.36	2.06	55.98	73.9	17.9	150	0	floor noise
Hori.	9848.000	PK	49.07	39.24	9.33	39.56	2.06	60.14	73.9	13.7	139	153	-
Hori.	2483.500	AV	38.48	28.40	14.23	38.62	2.06	44.55	53.9	9.3	100	264	VBW:2 kHz
Hori.	4924.000	AV	34.08	31.63	6.65	38.54	2.06	35.88	53.9	18.0	150	0	VBW:2 kHz, floor noise
Hori.	7386.000	AV	34.92	37.79	8.10	39.36	2.06	43.51	53.9	10.3	150	0	VBW:2 kHz, floor noise
Hori.	9848.000	AV	37.07	39.24	9.33	39.56	2.06	48.14	53.9	5.7	139	153	VBW:2 kHz
Vert.	2483.500	PK	50.17	28.40	14.23	38.62	2.06	56.24	73.9	17.6	100	339	-
Vert.	4924.000	PK	47.00	31.63	6.65	38.54	2.06	48.80	73.9	25.1	150	0	floor noise
Vert.	7386.000	PK	47.27	37.79	8.10	39.36	2.06	55.86	73.9	18.0	150	0	floor noise
Vert.	9848.000	PK	48.53	39.24	9.33	39.56	2.06	59.60	73.9	14.3	117	155	-
Vert.	2483.500	AV	36.01	28.40	14.23	38.62	2.06	42.08	53.9	11.8	100	339	VBW:2 kHz
Vert.	4924.000	AV	34.03	31.63	6.65	38.54	2.06	35.83	53.9	18.0	150	0	VBW:2 kHz, floor noise
Vert.	7386.000	AV	34.57	37.79	8.10	39.36	2.06	43.16	53.9	10.7	150	0	VBW:2 kHz, floor noise
Vert.	9848.000	AV	36.22	39.24	9.33	39.56	2.06	47.29	53.9	6.6	117	155	VBW:2 kHz

Result = Reading + Ant.Fac. + Loss (Cable+(Attenuator or Filter)(below 18 GHz)) - Gain(Amplifier) + Distance factor

Distance factor : 1 GHz - 10 GHz : 20log(3.80 m / 3.0 m) = 2.06 dB

10 GHz - 40 GHz : 20log(1.0 m / 3.0 m) = -9.54 dB

**UL Japan, Inc.**

**Shonan EMC Lab.**

1-22-3 Megumigaoka, Hiratsuka-shi, Kanagawa-ken, 259-1220 JAPAN

Telephone : +81 463 50 6400

Facsimile : +81 463 50 6401

**Radiated Spurious Emission**  
**(Reference Plot for band-edge)**

Report No. 13692701S-B-R1  
Test place Shonan EMC Lab.  
Semi Anechoic Chamber 2  
Date February 3, 2021  
Temperature / Humidity 22 deg.C, 38 %RH  
Engineer Takahiro Suzuki  
Mode Tx 11g 2462 MHz

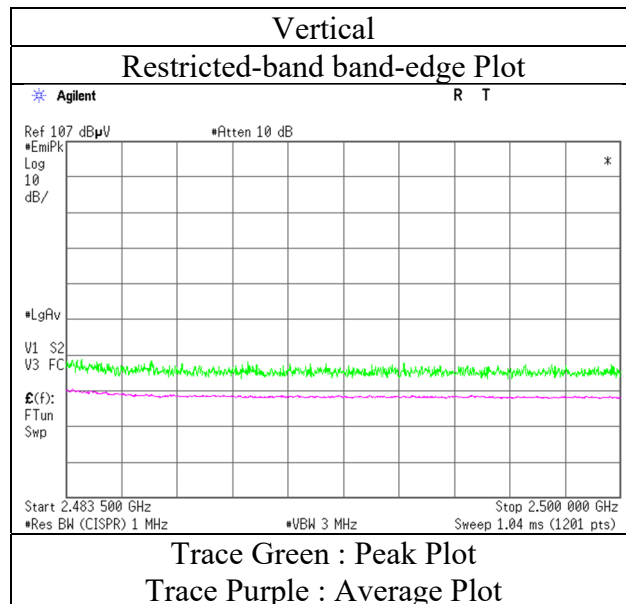
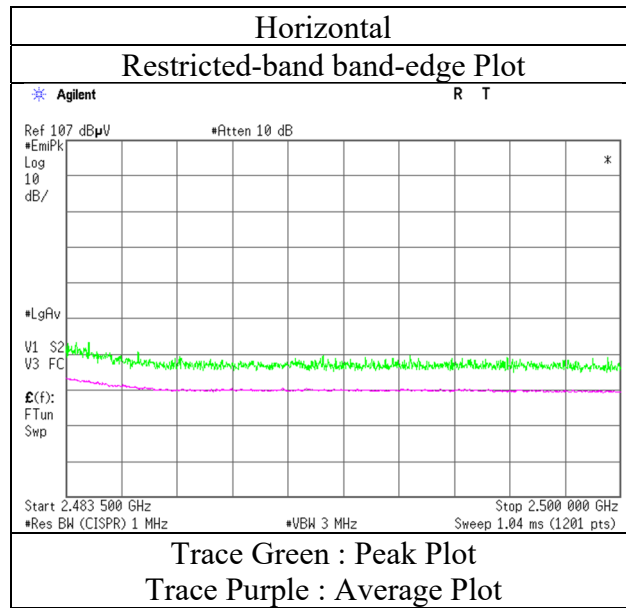

\* The measurement was conducted for a sufficiently long enough time to detect any possible spurious emissions. Final result of restricted band edge was shown in tabular data.

## Radiated Spurious Emission

Report No. 13692701S-B-R1  
Test place Shonan EMC Lab.  
Semi Anechoic Chamber 2 2 2  
Date February 3, 2021 February 4, 2021 February 5, 2021  
Temperature / Humidity 22 deg.C, 38 %RH 21 deg.C, 36 %RH 24 deg.C, 33 %RH  
Engineer Takahiro Suzuki Takahiro Suzuki Hiromasa Sato  
( 1 GHz -2.8 GHz ) ( 2.8 GHz -10 GHz ) ( 10 GHz -26.5 GHz )  
Mode Tx 11n-20 SISO 2412 MHz

(\* PK: Peak, AV: Average, QP: Quasi-Peak)

Polarity	Frequency [MHz]	Detector	Reading [dBuV]	Ant. Fac. [dB/m]	Loss [dB]	Gain [dB]	Distance Factor [dB]	Result [dBuV/m]	Limit [dBuV/m]	Margin [dB]	Height [cm]	Angle [deg]	Remark
Hori.	2390.000	PK	51.20	28.56	14.13	38.68	2.06	57.27	73.9	16.6	100	266	-
Hori.	4824.000	PK	46.53	31.60	6.59	38.54	2.06	48.24	73.9	25.6	150	0	floor noise
Hori.	7236.000	PK	46.73	37.65	8.02	39.17	2.06	55.29	73.9	18.6	150	0	floor noise
Hori.	9648.000	PK	47.82	38.83	9.25	39.67	2.06	58.29	73.9	15.6	142	155	-
Hori.	2390.000	AV	36.94	28.56	14.13	38.68	2.06	43.01	53.9	10.8	100	266	VBW:4.3 kHz
Hori.	4824.000	AV	34.97	31.60	6.59	38.54	2.06	36.68	53.9	17.2	150	0	VBW:4.3 kHz, floor noise
Hori.	7236.000	AV	35.77	37.65	8.02	39.17	2.06	44.33	53.9	9.5	150	0	VBW:4.3 kHz, floor noise
Hori.	9648.000	AV	36.26	38.83	9.25	39.67	2.06	46.73	53.9	7.1	142	155	VBW:4.3 kHz
Vert.	2390.000	PK	50.45	28.56	14.13	38.68	2.06	56.52	73.9	17.3	100	341	-
Vert.	4824.000	PK	46.18	31.60	6.59	38.54	2.06	47.89	73.9	26.0	150	0	floor noise
Vert.	7236.000	PK	47.19	37.65	8.02	39.17	2.06	55.75	73.9	18.1	150	0	floor noise
Vert.	9648.000	PK	48.08	38.83	9.25	39.67	2.06	58.55	73.9	15.3	100	130	-
Vert.	2390.000	AV	37.33	28.56	14.13	38.68	2.06	43.40	53.9	10.5	100	341	VBW:4.3 kHz
Vert.	4824.000	AV	35.04	31.60	6.59	38.54	2.06	36.75	53.9	17.1	150	0	VBW:4.3 kHz, floor noise
Vert.	7236.000	AV	35.62	37.65	8.02	39.17	2.06	44.18	53.9	9.7	150	0	VBW:4.3 kHz, floor noise
Vert.	9648.000	AV	37.28	38.83	9.25	39.67	2.06	47.75	53.9	6.1	100	130	VBW:4.3 kHz

Result = Reading + Ant. Fac. + Loss (Cable+(Attenuator or Filter)(below 18 GHz)) - Gain(Amplifier) + Distance factor

Distance factor : 1 GHz - 10 GHz : 20log(3.80 m / 3.0 m) = 2.06 dB

10 GHz - 40 GHz : 20log(1.0 m / 3.0 m) = -9.54 dB

### 20 dBc Data Sheet (RBW 100 kHz, VBW 300 kHz)

Polarity	Frequency [MHz]	Detector	Reading [dBuV]	Ant. Fac. [dB/m]	Loss [dB]	Gain [dB]	Distance Factor [dB]	Result [dBuV/m]	Limit [dBuV/m]	Margin [dB]	Remark
Hori.	2412.000	PK	86.87	28.52	14.15	38.66	2.06	92.94	-	-	Carrier
Hori.	2400.000	PK	50.48	28.54	14.15	38.67	2.06	56.56	72.9	16.3	-
Vert.	2412.000	PK	83.72	28.52	14.15	38.66	2.06	89.79	-	-	Carrier
Vert.	2400.000	PK	49.77	28.54	14.15	38.67	2.06	55.85	69.7	13.8	-

Result = Reading + Ant. Fac. + Loss (Cable+(Attenuator or Filter)(below 18 GHz)) - Gain(Amplifier) + Distance factor

Distance factor : 1 GHz - 10 GHz : 20log(3.80 m / 3.0 m) = 2.06 dB

10 GHz - 40 GHz : 20log(1.0 m / 3.0 m) = -9.54 dB

**UL Japan, Inc.**

**Shonan EMC Lab.**

1-22-3 Megumigaoka, Hiratsuka-shi, Kanagawa-ken, 259-1220 JAPAN

Telephone : +81 463 50 6400

Facsimile : +81 463 50 6401

## Radiated Spurious Emission (Reference Plot for band-edge)

Report No.	13692701S-B-R1
Test place	Shonan EMC Lab.
Semi Anechoic Chamber	2
Date	February 3, 2021
Temperature / Humidity	22 deg.C, 38 %RH
Engineer	Takahiro Suzuki
Mode	Tx 11n-20 SISO 2412 MHz

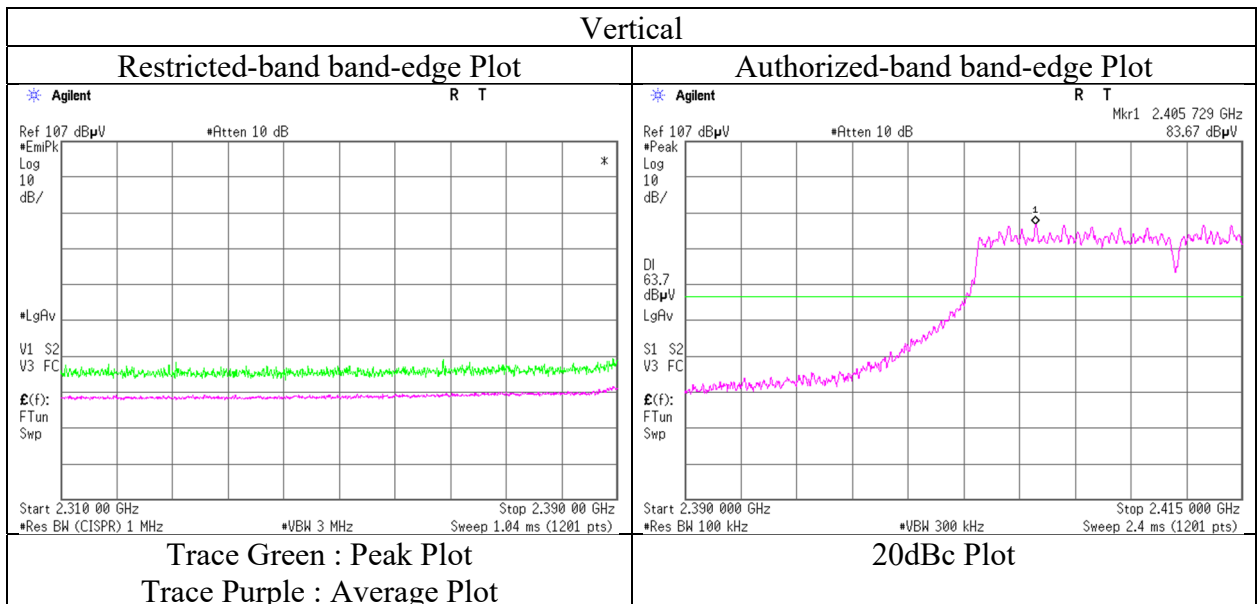
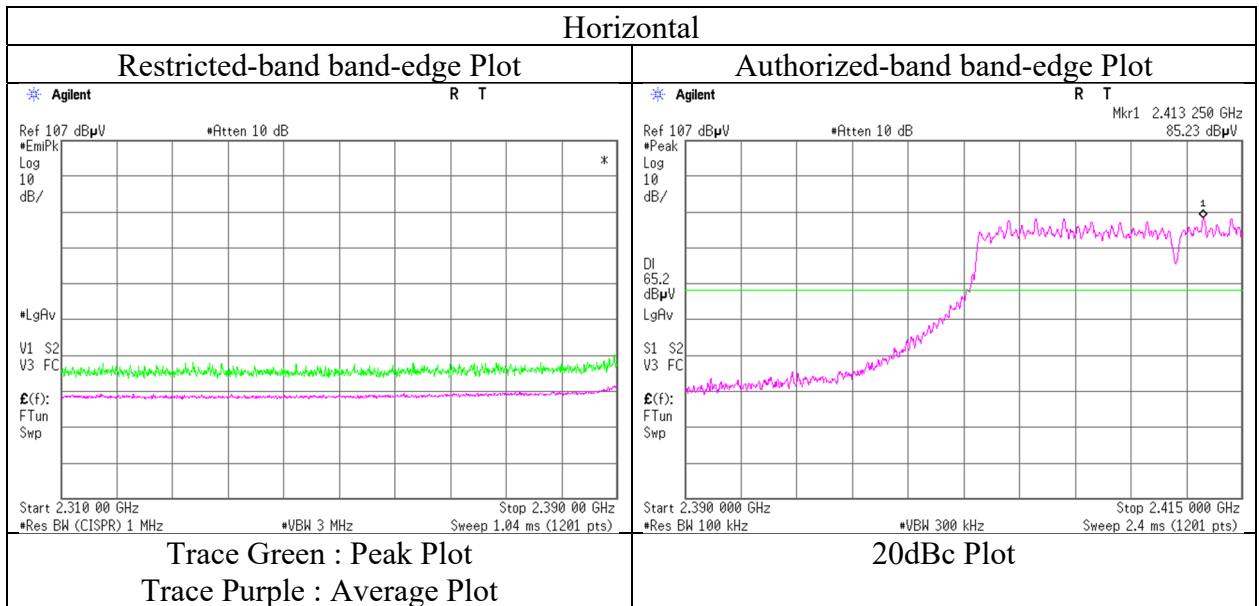

\* The measurement was conducted for a sufficiently long enough time to detect any possible spurious emissions. Final result of restricted band edge was shown in tabular data.

## Radiated Spurious Emission

Report No. 13692701S-B-R1  
Test place Shonan EMC Lab.  
Semi Anechoic Chamber 2 2 2  
Date February 3, 2021 February 4, 2021 February 5, 2021  
Temperature / Humidity 22 deg.C, 38 %RH 21 deg.C, 36 %RH 24 deg.C, 33 %RH  
Engineer Takahiro Suzuki Takahiro Suzuki Hiromasa Sato  
( 1 GHz -2.8 GHz ) ( 2.8 GHz -10 GHz ) ( 10 GHz -26.5 GHz )  
Mode Tx 11n-20 SISO 2437 MHz

(\* PK: Peak, AV: Average, QP: Quasi-Peak)

Polarity	Frequency [MHz]	Detector	Reading [dBuV]	Ant.Fac. [dB/m]	Loss [dB]	Gain [dB]	Distance Factor [dB]	Result [dBuV/m]	Limit [dBuV/m]	Margin [dB]	Height [cm]	Angle [deg]	Remark
Hori.	4874.000	PK	45.22	31.58	6.61	38.54	2.06	46.93	73.9	26.9	150	0	floor noise
Hori.	7311.000	PK	46.49	37.71	8.04	39.27	2.06	55.03	73.9	18.8	150	0	floor noise
Hori.	9748.000	PK	48.63	39.09	9.29	39.62	2.06	59.45	73.9	14.4	124	143	-
Hori.	4874.000	AV	34.40	31.58	6.61	38.54	2.06	36.11	53.9	17.7	150	0	VBW:4.3 kHz floor noise
Hori.	7311.000	AV	35.43	37.71	8.04	39.27	2.06	43.97	53.9	9.9	150	0	VBW:4.3 kHz floor noise
Hori.	9748.000	AV	37.98	39.09	9.29	39.62	2.06	48.80	53.9	5.1	124	143	VBW:4.3 kHz
Vert.	4874.000	PK	45.31	31.58	6.61	38.54	2.06	47.02	73.9	26.8	150	0	floor noise
Vert.	7311.000	PK	46.00	37.71	8.04	39.27	2.06	54.54	73.9	19.3	150	0	floor noise
Vert.	9748.000	PK	48.46	39.09	9.29	39.62	2.06	59.28	73.9	14.6	161	160	-
Vert.	4874.000	AV	34.67	31.58	6.61	38.54	2.06	36.38	53.9	17.5	150	0	VBW:4.3 kHz floor noise
Vert.	7311.000	AV	35.09	37.71	8.04	39.27	2.06	43.63	53.9	10.2	150	0	VBW:4.3 kHz floor noise
Vert.	9748.000	AV	37.71	39.09	9.29	39.62	2.06	48.53	53.9	5.3	161	160	VBW:4.3 kHz

Result = Reading + Ant.Fac. + Loss (Cable+(Attenuator or Filter)(below 18 GHz)) - Gain(Amplifier) + Distance factor  
Distance factor : 1 GHz - 10 GHz : 20log(3.80 m / 3.0 m) = 2.06 dB  
10 GHz - 40 GHz : 20log(1.0 m / 3.0 m) = -9.54 dB

## Radiated Spurious Emission

Report No.	13692701S-B-R1		
Test place	Shonan EMC Lab.		
Semi Anechoic Chamber	2	2	2
Date	February 3, 2021	February 4, 2021	February 5, 2021
Temperature / Humidity	22 deg.C, 38 %RH	21 deg.C, 36 %RH	24 deg.C, 33 %RH
Engineer	Takahiro Suzuki	Takahiro Suzuki	Hiromasa Sato
	( 1 GHz -2.8 GHz )	( 2.8 GHz -10 GHz )	( 10 GHz -26.5 GHz )
Mode	Tx 11n-20 SISO 2462 MHz		

(\* PK: Peak, AV: Average, QP: Quasi-Peak)

Polarity	Frequency [MHz]	Detector	Reading [dBuV]	Ant.Fac. [dB/m]	Loss [dB]	Gain [dB]	Distance Factor [dB]	Result [dBuV/m]	Limit [dBuV/m]	Margin [dB]	Height [cm]	Angle [deg]	Remark
Hori.	2483.500	PK	57.96	28.40	14.23	38.62	2.06	64.03	73.9	9.8	100	266	-
Hori.	4924.000	PK	45.75	31.63	6.65	38.54	2.06	47.55	73.9	26.3	150	0	floor noise
Hori.	7386.000	PK	46.34	37.79	8.10	39.36	2.06	54.93	73.9	18.9	150	0	floor noise
Hori.	9848.000	PK	49.14	39.24	9.33	39.56	2.06	60.21	73.9	13.6	100	150	-
Hori.	2483.500	AV	40.44	28.40	14.23	38.62	2.06	46.51	53.9	7.3	100	266	VBW:4.3 kHz
Hori.	4924.000	AV	34.75	31.63	6.65	38.54	2.06	36.55	53.9	17.3	150	0	VBW:4.3 kHz, floor noise
Hori.	7386.000	AV	35.42	37.79	8.10	39.36	2.06	44.01	53.9	9.8	150	0	VBW:4.3 kHz, floor noise
Hori.	9848.000	AV	36.72	39.24	9.33	39.56	2.06	47.79	53.9	6.1	100	150	VBW:4.3 kHz
Vert.	2483.500	PK	53.32	28.40	14.23	38.62	2.06	59.39	73.9	14.5	100	74	-
Vert.	4924.000	PK	46.78	31.63	6.65	38.54	2.06	48.58	73.9	25.3	150	0	floor noise
Vert.	7386.000	PK	47.19	37.79	8.10	39.36	2.06	55.78	73.9	18.1	150	0	floor noise
Vert.	9848.000	PK	48.94	39.24	9.33	39.56	2.06	60.01	73.9	13.8	168	165	-
Vert.	2483.500	AV	38.78	28.40	14.23	38.62	2.06	44.85	53.9	9.0	100	74	VBW:4.3 kHz
Vert.	4924.000	AV	34.73	31.63	6.65	38.54	2.06	36.53	53.9	17.3	150	0	VBW:4.3 kHz, floor noise
Vert.	7386.000	AV	35.31	37.79	8.10	39.36	2.06	43.90	53.9	10.0	150	0	VBW:4.3 kHz, floor noise
Vert.	9848.000	AV	37.31	39.24	9.33	39.56	2.06	48.38	53.9	5.5	168	165	VBW:4.3 kHz

Result = Reading + Ant.Fac. + Loss (Cable+(Attenuator or Filter)(below 18 GHz)) - Gain(Amplifier) + Distance factor

Distance factor : 1 GHz - 10 GHz : 20log(3.80 m / 3.0 m) = 2.06 dB

10 GHz - 40 GHz : 20log(1.0 m / 3.0 m) = -9.54 dB

**Radiated Spurious Emission**  
**(Reference Plot for band-edge)**

Report No. 13692701S-B-R1  
Test place Shonan EMC Lab.  
Semi Anechoic Chamber 2  
Date February 3, 2021  
Temperature / Humidity 22 deg.C, 38 %RH  
Engineer Takahiro Suzuki  
Mode Tx 11n-20 SISO 2462 MHz

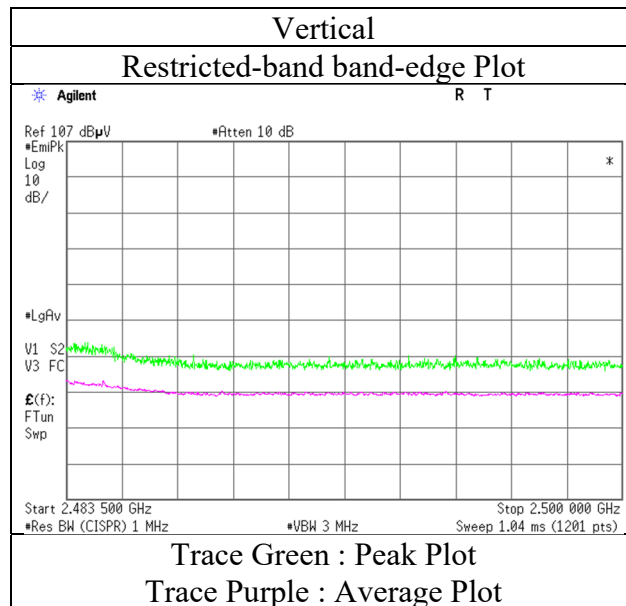
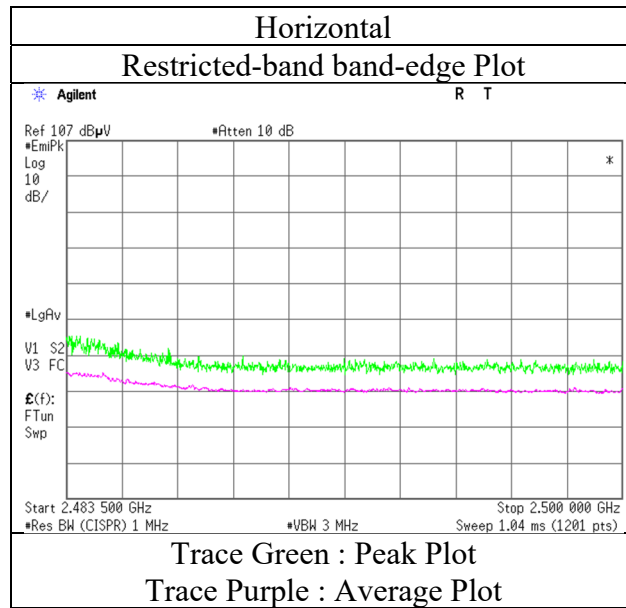

\* The measurement was conducted for a sufficiently long enough time to detect any possible spurious emissions. Final result of restricted band edge was shown in tabular data.

## Radiated Spurious Emission

Report No.	13692701S-B-R1			
Test place	Shonan EMC Lab.			
Semi Anechoic Chamber	2	2	2	2
Date	March 12, 2021	February 3, 2021	February 4, 2021	February 5, 2021
Temperature / Humidity	24 deg.C, 30 %RH	22 deg.C, 38 %RH	21 deg.C, 36 %RH	24 deg.C, 33 %RH
Engineer	Toshinori Yamada	Takahiro Suzuki	Takahiro Suzuki	Hhiromasa Sato
	( 30 MHz -1 GHz )	( 1 GHz -2.8 GHz )	( 2.8 GHz -10 GHz )	( 10 GHz -26.5 GHz )
Mode	Tx 11n-20 MIMO 2412 MHz			

(\* PK: Peak, AV: Average, QP: Quasi-Peak)

Polarity	Frequency [MHz]	Detector	Reading [dBuV]	Ant.Fac. [dB/m]	Loss [dB]	Gain [dB]	Distance Factor [dB]	Result [dBuV/m]	Limit [dBuV/m]	Margin [dB]	Height [cm]	Angle [deg]	Remark
Hori.	138.384	QP	32.50	14.37	8.35	31.83	0.00	23.39	43.5	20.1	231	190	-
Hori.	326.197	QP	38.50	14.38	6.58	31.66	0.00	27.80	46.0	18.2	147	88	-
Hori.	371.905	QP	37.00	15.11	6.86	31.63	0.00	27.34	46.0	18.6	100	182	-
Hori.	480.001	QP	43.20	17.27	7.50	31.62	0.00	36.35	46.0	9.6	100	82	-
Hori.	511.094	QP	34.20	17.71	7.64	31.62	0.00	27.93	46.0	18.0	100	142	-
Hori.	959.700	QP	34.20	22.10	9.72	30.42	0.00	35.60	46.0	10.4	100	182	-
Hori.	2390.000	PK	51.38	28.56	14.13	38.68	2.06	57.45	73.9	16.4	100	267	-
Hori.	4824.000	PK	46.32	31.60	6.59	38.54	2.06	48.03	73.9	25.8	150	0	floor noise
Hori.	7236.000	PK	47.19	37.65	8.02	39.17	2.06	55.75	73.9	18.1	150	0	floor noise
Hori.	9648.000	PK	48.54	38.83	9.25	39.67	2.06	59.01	73.9	14.8	107	152	-
Hori.	2390.000	AV	38.50	28.56	14.13	38.68	2.06	44.57	53.9	9.3	100	267	VBW:6.8 kHz
Hori.	4824.000	AV	35.51	31.60	6.59	38.54	2.06	37.22	53.9	16.6	150	0	VBW:6.8 kHz, floor noise
Hori.	7236.000	AV	36.10	37.65	8.02	39.17	2.06	44.66	53.9	9.2	150	0	VBW:6.8 kHz, floor noise
Hori.	9648.000	AV	38.22	38.83	9.25	39.67	2.06	48.69	53.9	5.2	107	152	VBW:6.8 kHz
Vert.	44.595	QP	36.10	13.17	7.17	31.91	0.00	24.53	40.0	15.4	100	188	-
Vert.	47.869	QP	37.30	11.98	7.21	31.90	0.00	24.59	40.0	15.4	100	182	-
Vert.	52.783	QP	39.10	10.26	7.23	31.90	0.00	24.69	40.0	15.3	100	212	-
Vert.	138.918	QP	34.80	14.39	8.37	31.83	0.00	25.73	43.5	17.7	100	219	-
Vert.	144.118	QP	36.20	14.69	8.49	31.83	0.00	27.55	43.5	15.9	100	264	-
Vert.	322.358	QP	39.10	14.22	6.55	31.66	0.00	28.21	46.0	17.7	100	224	-
Vert.	2390.000	PK	51.70	28.56	14.13	38.68	2.06	57.77	73.9	16.1	100	340	-
Vert.	4824.000	PK	46.31	31.60	6.59	38.54	2.06	48.02	73.9	25.8	150	0	floor noise
Vert.	7236.000	PK	47.50	37.65	8.02	39.17	2.06	56.06	73.9	17.8	150	0	floor noise
Vert.	9648.000	PK	48.82	38.83	9.25	39.67	2.06	59.29	73.9	14.6	100	129	-
Vert.	2390.000	AV	37.82	28.56	14.13	38.68	2.06	43.89	53.9	10.0	100	340	VBW:6.8 kHz
Vert.	4824.000	AV	35.40	31.60	6.59	38.54	2.06	37.11	53.9	16.7	150	0	VBW:6.8 kHz, floor noise
Vert.	7236.000	AV	36.03	37.65	8.02	39.17	2.06	44.59	53.9	9.3	150	0	VBW:6.8 kHz, floor noise
Vert.	9648.000	AV	39.01	38.83	9.25	39.67	2.06	49.48	53.9	4.4	100	129	VBW:6.8 kHz

Result = Reading + Ant.Fac. + Loss (Cable+(Attenuator or Filter)(below 18 GHz)) - Gain(Amplifier) + Distance factor

Distance factor : 1 GHz - 10 GHz : 20log(3.80 m / 3.0 m) = 2.06 dB  
10 GHz - 40 GHz : 20log(1.0 m / 3.0 m) = -9.54 dB

### 20 dBc Data Sheet (RBW 100 kHz, VBW 300 kHz)

Polarity	Frequency [MHz]	Detector	Reading [dBuV]	Ant.Fac. [dB/m]	Loss [dB]	Gain [dB]	Distance Factor [dB]	Result [dBuV/m]	Limit [dBuV/m]	Margin [dB]	Remark
Hori.	2412.000	PK	88.99	28.52	14.15	38.66	2.06	95.06	-	-	Carrier
Hori.	2400.000	PK	50.35	28.54	14.15	38.67	2.06	56.43	75.0	18.5	-
Vert.	2412.000	PK	86.88	28.52	14.15	38.66	2.06	92.95	-	-	Carrier
Vert.	2400.000	PK	49.13	28.54	14.15	38.67	2.06	55.21	72.9	17.6	-

Result = Reading + Ant.Fac. + Loss (Cable+(Attenuator or Filter)(below 18 GHz)) - Gain(Amplifier) + Distance factor

Distance factor : 1 GHz - 10 GHz : 20log(3.80 m / 3.0 m) = 2.06 dB  
10 GHz - 40 GHz : 20log(1.0 m / 3.0 m) = -9.54 dB

**UL Japan, Inc.**

**Shonan EMC Lab.**

1-22-3 Megumigaoka, Hiratsuka-shi, Kanagawa-ken, 259-1220 JAPAN

Telephone : +81 463 50 6400

Facsimile : +81 463 50 6401



## Radiated Spurious Emission (Reference Plot for band-edge)

Report No.	13692701S-B-R1
Test place	Shonan EMC Lab.
Semi Anechoic Chamber	2
Date	February 3, 2021
Temperature / Humidity	22 deg.C, 38 %RH
Engineer	Takahiro Suzuki
Mode	Tx 11n-20 MIMO 2412 MHz

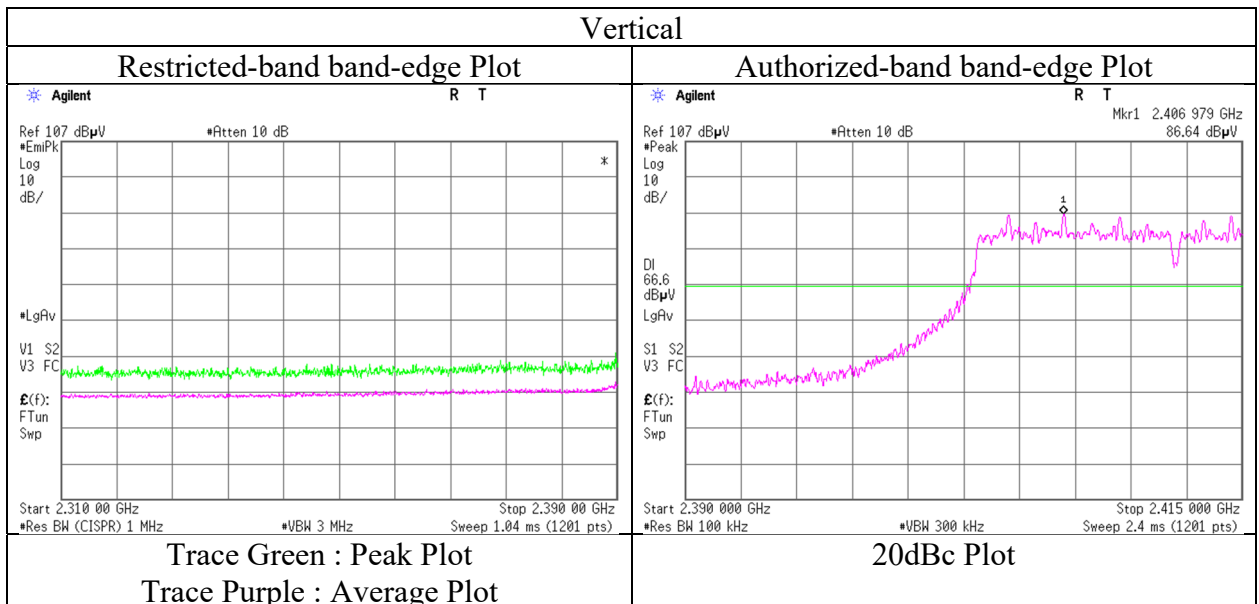
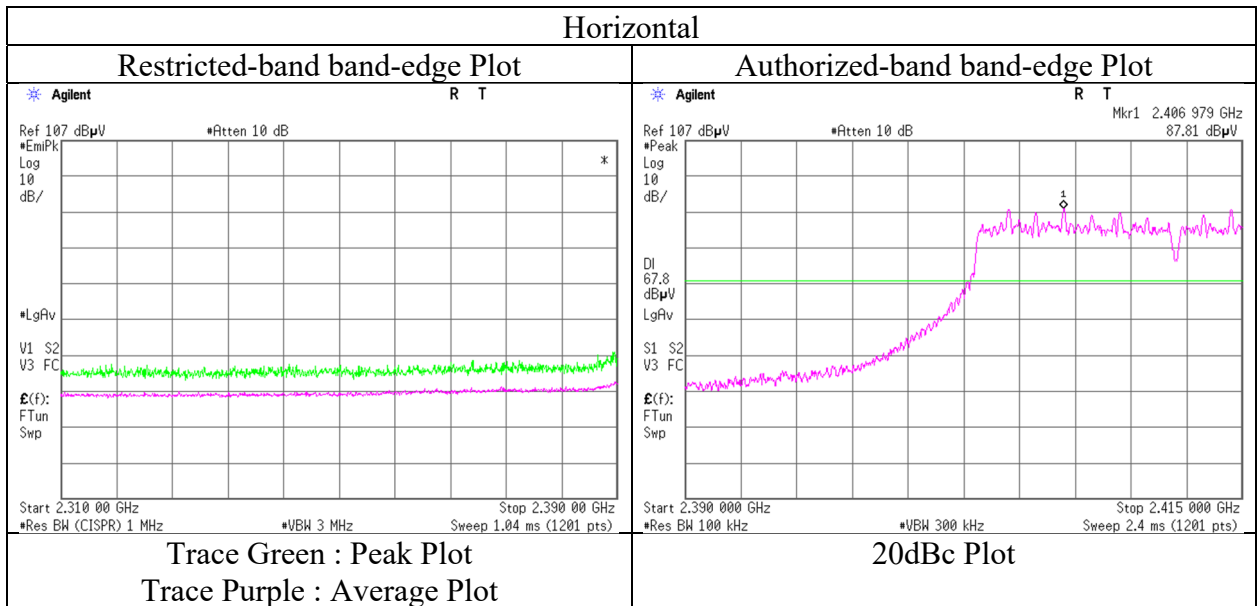

\* The measurement was conducted for a sufficiently long enough time to detect any possible spurious emissions. Final result of restricted band edge was shown in tabular data.

## Radiated Spurious Emission

Report No. 13692701S-B-R1  
Test place Shonan EMC Lab.  
Semi Anechoic Chamber 2 2 2  
Date February 3, 2021 February 4, 2021 February 5, 2021  
Temperature / Humidity 22 deg.C, 38 %RH 21 deg.C, 36 %RH 24 deg.C, 33 %RH  
Engineer Takahiro Suzuki Takahiro Suzuki Hiromasa Sato  
( 1 GHz -2.8 GHz ) ( 2.8 GHz -10 GHz ) ( 10 GHz -26.5 GHz )  
Mode Tx 11n-20 MIMO 2437 MHz

(\* PK: Peak, AV: Average, QP: Quasi-Peak)

Polarity	Frequency [MHz]	Detector	Reading [dBuV]	Ant.Fac. [dB/m]	Loss [dB]	Gain [dB]	Distance Factor [dB]	Result [dBuV/m]	Limit [dBuV/m]	Margin [dB]	Height [cm]	Angle [deg]	Remark
Hori.	4874.000	PK	45.56	31.58	6.61	38.54	2.06	47.27	73.9	26.6	150	0	floor noise
Hori.	7311.000	PK	46.78	37.71	8.04	39.27	2.06	55.32	73.9	18.5	150	0	floor noise
Hori.	9748.000	PK	49.92	39.09	9.29	39.62	2.06	60.74	73.9	13.1	139	154	-
Hori.	4874.000	AV	33.67	31.58	6.61	38.54	2.06	35.38	53.9	18.5	150	0	VBW:6.8 kHz, floor noise
Hori.	7311.000	AV	34.63	37.71	8.04	39.27	2.06	43.17	53.9	10.7	150	0	VBW:6.8 kHz, floor noise
Hori.	9748.000	AV	38.76	39.09	9.29	39.62	2.06	49.58	53.9	4.3	139	154	VBW:6.8 kHz
Vert.	4874.000	PK	45.27	31.58	6.61	38.54	2.06	46.98	73.9	26.9	150	0	floor noise
Vert.	7311.000	PK	46.66	37.71	8.04	39.27	2.06	55.20	73.9	18.7	150	0	floor noise
Vert.	9748.000	PK	49.79	39.09	9.29	39.62	2.06	60.61	73.9	13.2	109	131	-
Vert.	4874.000	AV	35.35	31.58	6.61	38.54	2.06	37.06	53.9	16.8	150	0	VBW:6.8 kHz, floor noise
Vert.	7311.000	AV	35.91	37.71	8.04	39.27	2.06	44.45	53.9	9.4	150	0	VBW:6.8 kHz, floor noise
Vert.	9748.000	AV	38.92	39.09	9.29	39.62	2.06	49.74	53.9	4.1	109	131	VBW:6.8 kHz

Result = Reading + Ant.Fac. + Loss (Cable+(Attenuator or Filter)(below 18 GHz)) - Gain(Amplifier) + Distance factor

Distance factor : 1 GHz - 10 GHz : 20log (3.80 m / 3.0 m) = 2.06 dB

10 GHz - 40 GHz : 20log (1.0 m / 3.0 m) = -9.54 dB

**UL Japan, Inc.**

**Shonan EMC Lab.**

1-22-3 Megumigaoka, Hiratsuka-shi, Kanagawa-ken, 259-1220 JAPAN

Telephone : +81 463 50 6400

Facsimile : +81 463 50 6401

## Radiated Spurious Emission

Report No. 13692701S-B-R1  
Test place Shonan EMC Lab.  
Semi Anechoic Chamber 2 2 2  
Date February 3, 2021 February 4, 2021 February 5, 2021  
Temperature / Humidity 22 deg.C, 38 %RH 21 deg.C, 36 %RH 24 deg.C, 33 %RH  
Engineer Takahiro Suzuki Takahiro Suzuki Hiromasa Sato  
( 1 GHz -2.8 GHz ) ( 2.8 GHz -10 GHz ) ( 10 GHz -26.5 GHz )  
Mode Tx 11n-20 MIMO 2462 MHz

(\* PK: Peak, AV: Average, QP: Quasi-Peak)

Polarity	Frequency [MHz]	Detector	Reading [dBuV]	Ant.Fac. [dB/m]	Loss [dB]	Gain [dB]	Distance Factor [dB]	Result [dBuV/m]	Limit [dBuV/m]	Margin [dB]	Height [cm]	Angle [deg]	Remark
Hori.	2483.500	PK	56.98	28.40	14.23	38.62	2.06	63.05	73.9	10.8	100	262	-
Hori.	4924.000	PK	46.00	31.63	6.65	38.54	2.06	47.80	73.9	26.1	150	0	floor noise
Hori.	7386.000	PK	46.14	37.79	8.10	39.36	2.06	54.73	73.9	19.1	150	0	floor noise
Hori.	9848.000	PK	48.86	39.24	9.33	39.56	2.06	59.93	73.9	13.9	146	158	-
Hori.	2483.500	AV	41.44	28.40	14.23	38.62	2.06	47.51	53.9	6.3	100	262	VBW:6.8 kHz
Hori.	4924.000	AV	34.96	31.63	6.65	38.54	2.06	36.76	53.9	17.1	150	0	VBW:6.8 kHz, floor noise
Hori.	7386.000	AV	35.76	37.79	8.10	39.36	2.06	44.35	53.9	9.5	150	0	VBW:6.8 kHz, floor noise
Hori.	9848.000	AV	38.22	39.24	9.33	39.56	2.06	49.29	53.9	4.6	146	158	VBW:6.8 kHz
Vert.	2483.500	PK	54.70	28.40	14.23	38.62	2.06	60.77	73.9	13.1	100	338	-
Vert.	4924.000	PK	47.00	31.63	6.65	38.54	2.06	48.80	73.9	25.1	150	0	floor noise
Vert.	7386.000	PK	47.23	37.79	8.10	39.36	2.06	55.82	73.9	18.0	150	0	floor noise
Vert.	9848.000	PK	48.83	39.24	9.33	39.56	2.06	59.90	73.9	14.0	172	160	-
Vert.	2483.500	AV	38.86	28.40	14.23	38.62	2.06	44.93	53.9	8.9	100	338	VBW:6.8 kHz
Vert.	4924.000	AV	35.26	31.63	6.65	38.54	2.06	37.06	53.9	16.8	150	0	VBW:6.8 kHz, floor noise
Vert.	7386.000	AV	35.96	37.79	8.10	39.36	2.06	44.55	53.9	9.3	150	0	VBW:6.8 kHz, floor noise
Vert.	9848.000	AV	38.71	39.24	9.33	39.56	2.06	49.78	53.9	4.1	172	160	VBW:6.8 kHz

Result = Reading + Ant.Fac. + Loss (Cable+(Attenuator or Filter)(below 18 GHz)) - Gain(Amplifier) + Distance factor

Distance factor : 1 GHz - 10 GHz : 20log(3.80 m / 3.0 m) = 2.06 dB

10 GHz - 40 GHz : 20log(1.0 m / 3.0 m) = -9.54 dB

**UL Japan, Inc.**

**Shonan EMC Lab.**

1-22-3 Megumigaoka, Hiratsuka-shi, Kanagawa-ken, 259-1220 JAPAN

Telephone : +81 463 50 6400

Facsimile : +81 463 50 6401

**Radiated Spurious Emission**  
**(Reference Plot for band-edge)**

Report No. 13692701S-B-R1  
Test place Shonan EMC Lab.  
Semi Anechoic Chamber 2  
Date February 3, 2021  
Temperature / Humidity 22 deg.C, 38 %RH  
Engineer Takahiro Suzuki  
Mode Tx 11n-20 MIMO 2462 MHz

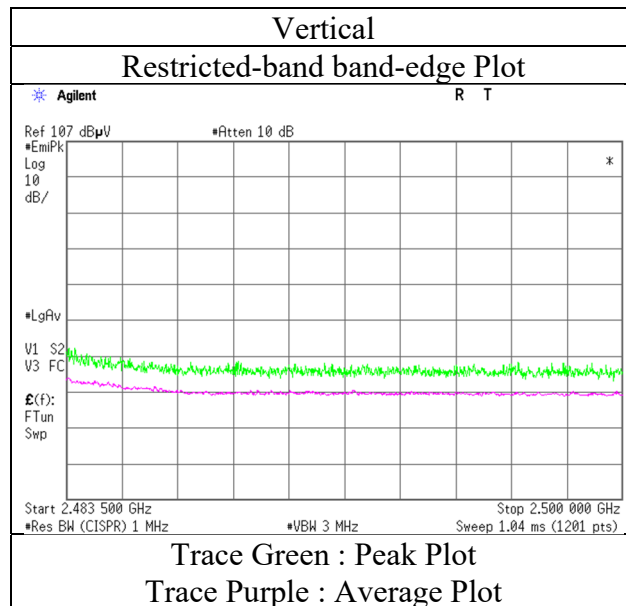
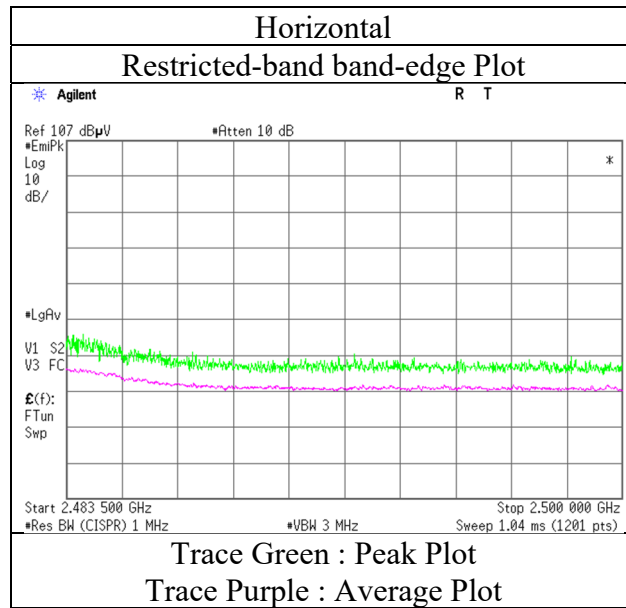

\* The measurement was conducted for a sufficiently long enough time to detect any possible spurious emissions. Final result of restricted band edge was shown in tabular data.

**Radiated Spurious Emission**  
**(Plot data, Worst case)**

Report No.	13692701S-B-R1			
Test place	Shonan EMC Lab.			
Semi Anechoic Chamber	2	2	2	2
Date	March 12, 2021	February 3, 2021	February 4, 2021	February 5, 2021
Temperature / Humidity	24 deg.C, 30 %RH	22 deg.C, 38 %RH	21 deg.C, 36 %RH	24 deg.C, 33 %RH
Engineer	Toshinori Yamada	Takahiro Suzuki	Takahiro Suzuki	Hiromasa Sato
	( 30 MHz -1 GHz )	( 1 GHz -2.8 GHz )	( 2.8 GHz -10 GHz )	( 10 GHz -26.5 GHz )
Mode	Tx 11n-20 MIMO 2412 MHz			

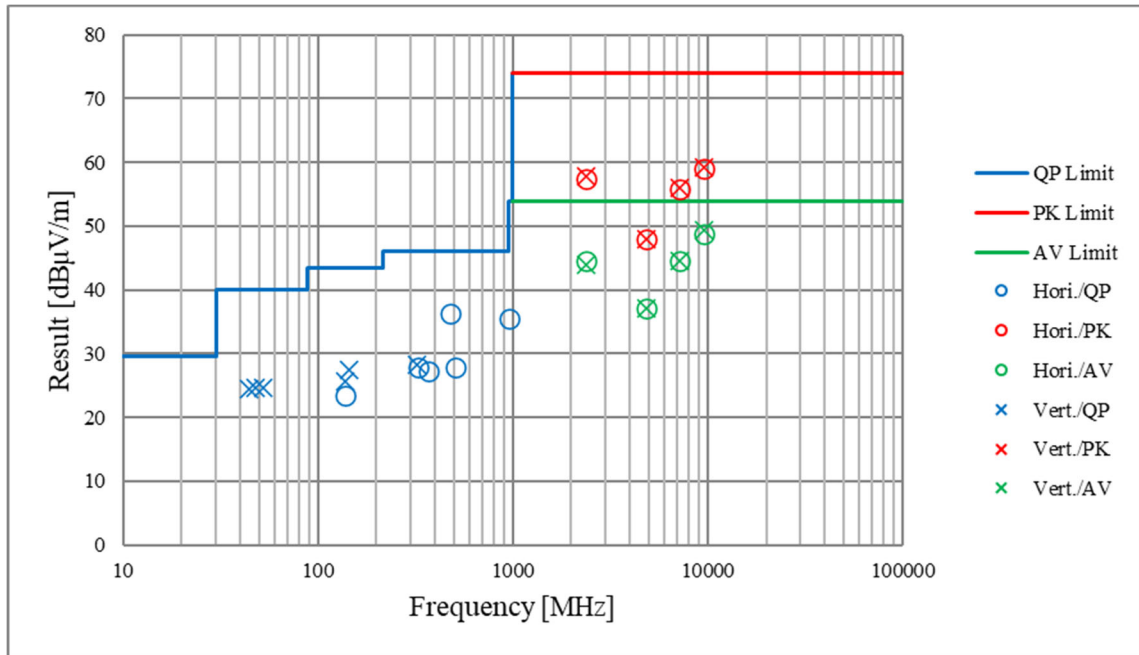

\*These plots data contains sufficient number to show the trend of characteristic features for EUT.