

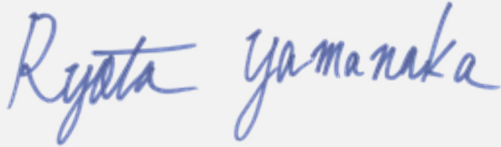

# RADIO TEST REPORT

## Test Report No. 15243568H-A-R1

<b>Customer</b>	DENSO CORPORATION
<b>Description of EUT</b>	Millimeter Wave Radar Sensor
<b>Model Number of EUT</b>	DNMWR018
<b>FCC ID</b>	HYQDNMWR018
<b>Test Regulation</b>	FCC Part 95 Subpart M
<b>Test Result</b>	Complied
<b>Issue Date</b>	July 4, 2024
<b>Remarks</b>	-

<b>Representative test engineer</b>	<b>Approved by</b>
	
Junki Nagatomi Engineer	Ryota Yamanaka Engineer
 	
CERTIFICATE 5107.02	
<input type="checkbox"/> The testing in which "Non-accreditation" is displayed is outside the accreditation scopes in UL Japan, Inc.	
<input checked="" type="checkbox"/> There is no testing item of "Non-accreditation".	

Report Cover Page - Form-ULID-003532 (DCS:13-EM-F0429) Issue# 23.0

## ANNOUNCEMENT

- This test report shall not be reproduced in full or partial, without the written approval of UL Japan, Inc.
- The results in this report apply only to the sample tested. (Laboratory was not involved in sampling.)
- This sample tested is in compliance with the limits of the above regulation.
- The test results in this test report are traceable to the national or international standards.
- This test report must not be used by the customer to claim product certification, approval, or endorsement by the A2LA accreditation body.
- This test report covers Radio technical requirements.  
It does not cover administrative issues such as Manual or non-Radio test related Requirements. (if applicable)
- The all test items in this test report are conducted by UL Japan, Inc. Ise EMC Lab.
- The opinions and the interpretations to the result of the description in this report are outside scopes where UL Japan, Inc. has been accredited.
- The information provided by the customer for this report is identified in SECTION 1.
- The laboratory is not responsible for information provided by the customer which can impact the validity of the results.
- For test report(s) referred in this report, the latest version (including any revisions) is always referred.

## REVISION HISTORY

### Original Test Report No.: 15243568H-A

This report is a revised version of 15243568H-A. 15243568H-A is replaced with this report.

Revision	Test Report No.	Date	Page Revised Contents
- (Original)	15243568H-A	June 18, 2024	-
1	15243568H-A-R1	July 4, 2024	Addition of the Tx BIST description to Clause 4.1.
1	15243568H-A-R1	July 4, 2024	Deletion of the note under the Occupied bandwidth (Tx BIST) data. (*Tx BIST ~ Mode 2.)
1	15243568H-A-R1	July 4, 2024	Correction of the note under the data for Radiated Power (Tx Mode 1, 2).
1	15243568H-A-R1	July 4, 2024	Correction of the FCM1 duty factor for Radiated Power (Tx Mode 2) data; from 5.16 to 5.02.
1	15243568H-A-R1	July 4, 2024	Correction of the following contents in Radiated Power (Tx BIST) data. - Change the Marker 2 for Remarks; from *2 to *1. - Correction of the note *1.
1	15243568H-A-R1	July 4, 2024	Correction of the CW section total time of Tx on time for Modulation characteristics (Tx (Mode 1) FCM 2); from 522.605 to 522.604.
1	15243568H-A-R1	July 4, 2024	Correction of the Tx On + Tx Off time for Modulation characteristics (Tx BIST); from 50.003 to 50.000
1	15243568H-A-R1	July 4, 2024	Correction of the following value in Modulation characteristics (Tx (Mode 2) FCM 1 Low) data. - FCM1 section: from 15.236 to 15.235 - Total: from 15.235 to 15.728 - Duty factor: from 5.16 to 5.02
1	15243568H-A-R1	July 4, 2024	Correction of the Remarks for Frequency Stability data; from "minimum / maximum voltage" to "rated voltage"

**Reference: Abbreviations (Including words undescribed in this report)**

A2LA	The American Association for Laboratory Accreditation	ICES	Interference-Causing Equipment Standard
AC	Alternating Current	IEC	International Electrotechnical Commission
AFH	Adaptive Frequency Hopping	IEEE	Institute of Electrical and Electronics Engineers
AM	Amplitude Modulation	IF	Intermediate Frequency
Amp, AMP	Amplifier	ILAC	International Laboratory Accreditation Conference
ANSI	American National Standards Institute	ISED	Innovation, Science and Economic Development Canada
Ant, ANT	Antenna	ISO	International Organization for Standardization
AP	Access Point	JAB	Japan Accreditation Board
ASK	Amplitude Shift Keying	LAN	Local Area Network
Atten., ATT	Attenuator	LIMS	Laboratory Information Management System
AV	Average	MCS	Modulation and Coding Scheme
BPSK	Binary Phase-Shift Keying	MRA	Mutual Recognition Arrangement
BR	Bluetooth Basic Rate	N/A	Not Applicable
BT	Bluetooth	NIST	National Institute of Standards and Technology
BT LE	Bluetooth Low Energy	NS	No signal detect.
BW	BandWidth	NSA	Normalized Site Attenuation
Cal Int	Calibration Interval	NVLAP	National Voluntary Laboratory Accreditation Program
CCK	Complementary Code Keying	OBW	Occupied Band Width
Ch., CH	Channel	OFDM	Orthogonal Frequency Division Multiplexing
CISPR	Comite International Special des Perturbations Radioelectriques	P/M	Power meter
CW	Continuous Wave	PCB	Printed Circuit Board
DBPSK	Differential BPSK	PER	Packet Error Rate
DC	Direct Current	PHY	Physical Layer
D-factor	Distance factor	PK	Peak
DFS	Dynamic Frequency Selection	PN	Pseudo random Noise
DQPSK	Differential QPSK	PRBS	Pseudo-Random Bit Sequence
DSSS	Direct Sequence Spread Spectrum	PSD	Power Spectral Density
EDR	Enhanced Data Rate	QAM	Quadrature Amplitude Modulation
EIRP, e.i.r.p.	Equivalent Isotropically Radiated Power	QP	Quasi-Peak
EMC	ElectroMagnetic Compatibility	QPSK	Quadri-Phase Shift Keying
EMI	ElectroMagnetic Interference	RBW	Resolution Band Width
EN	European Norm	RDS	Radio Data System
ERP, e.r.p.	Effective Radiated Power	RE	Radio Equipment
EU	European Union	RF	Radio Frequency
EUT	Equipment Under Test	RMS	Root Mean Square
Fac.	Factor	RSS	Radio Standards Specifications
FCC	Federal Communications Commission	Rx	Receiving
FHSS	Frequency Hopping Spread Spectrum	SA, S/A	Spectrum Analyzer
FM	Frequency Modulation	SG	Signal Generator
Freq.	Frequency	SVSWR	Site-Voltage Standing Wave Ratio
FSK	Frequency Shift Keying	TR	Test Receiver
GFSK	Gaussian Frequency-Shift Keying	Tx	Transmitting
GNSS	Global Navigation Satellite System	VBW	Video BandWidth
GPS	Global Positioning System	Vert.	Vertical
Hori.	Horizontal	WLAN	Wireless LAN

---

<b>CONTENTS</b>	<b>PAGE</b>
<b>SECTION 1: Customer Information .....</b>	<b>5</b>
<b>SECTION 2: Equipment Under Test (EUT).....</b>	<b>5</b>
<b>SECTION 3: Test specification, procedures &amp; results .....</b>	<b>6</b>
<b>SECTION 4: Operation of EUT during testing .....</b>	<b>9</b>
<b>SECTION 5: Radiated Spurious Emission.....</b>	<b>11</b>
<b>SECTION 6: Frequency Stability .....</b>	<b>17</b>
<b>APPENDIX 1: Test data .....</b>	<b>18</b>
Occupied bandwidth .....	18
Radiated Power .....	21
Modulation characteristics .....	29
Field strength of spurious radiation.....	38
Frequency Stability .....	46
<b>APPENDIX 2: Test instruments .....</b>	<b>48</b>
<b>APPENDIX 3: Photographs of test setup.....</b>	<b>50</b>
Radiated Power .....	50
Field strength of spurious radiation.....	51
Worst Case Position .....	54
Frequency Stability .....	55

## **SECTION 1: Customer Information**

Company Name	DENSO CORPORATION
Address	1-1, Showa-cho, Kariya-shi, Aichi-ken, 448-8661, Japan
Telephone Number	+81-566-56-0312
Contact Person	Hideshi Izuhara

The information provided by the customer is as follows;

- Customer, Description of EUT, Model Number of EUT, FCC ID on the cover and other relevant pages
- Operating/Test Mode(s) (Mode(s)) on all the relevant pages
- SECTION 1: Customer Information
- SECTION 2: Equipment Under Test (EUT) other than the Receipt Date and Test Date
- SECTION 4: Operation of EUT during testing

## **SECTION 2: Equipment Under Test (EUT)**

### **2.1 Identification of EUT**

Description	Millimeter Wave Radar Sensor
Model Number	DNMWR018
Serial Number	Refer to SECTION 4.2
Condition	Pre-production (Not for Sale: This sample is equivalent to production version.)
Modification	No Modification by the test lab
Receipt Date	April 7, 2024
Test Date	April 10 to May 11, 2024

### **2.2 Product Description**

#### **General Specification**

Rating	DC 12 V (Car battery), DC 5.8 V to 16 V (Operating range)
Operating temperature	-40 deg. C to +85 deg. C

#### **Radio Specification**

Equipment Type	Transceiver
Frequency of Operation	76 GHz to 77 GHz (FCM 1: 76.3 GHz, 76.5 GHz, 76.7 GHz / FCM 2: 76.5 GHz / Tx BIST: 76.5 GHz)
Bandwidth	FCM 1: 500 MHz (Max) / FCM 2: 980 MHz (Max) / Tx_BIST: 300 MHz (Max)
Type of Modulation	Fast chirp modulation (FCM)
Emission Classification	QXN
Antenna Gain	FCM 1: 16.91 dBi (typ) / FCM 2: 16.87 dBi (typ) / Tx_BIST: 15.04 dBi (typ)
Steerable Antenna	Fixed beam
Usage location	Vehicle-mounted

## **SECTION 3: Test specification, procedures & results**

### **3.1 Test Specification**

Test Specification	FCC Part 95 Subpart M The latest version on the first day of the testing period
Title	FCC 47CFR Part95 – PERSONAL RADIO SERVICES Subpart M – The 76-81 GHz Band Radar Service

### **3.2 Procedures and results**

Item	Test Procedure	Specification	Worst margin	Results	Remarks
Conducted emission	<b>FCC:</b> N/A	<b>FCC:</b> N/A	N/A	N/A	*1)
Occupied bandwidth	<b>FCC:</b> ANSI C63.26-2015 5.4 Occupied bandwidth	<b>FCC:</b> Section 2.1049	See data.	Complied	Radiated
Radiated Power	<b>FCC:</b> ANSI C63.26-2015 5.5 Radiated emissions testing	<b>FCC:</b> Section 95.3367 Section 2.1046 Section 2.1047		Complied	Radiated
Modulation characteristics	ANSI C63.10-2013 6. Standard test methods 9. Procedures for testing millimeter-wave systems				
Field strength of spurious radiation	<b>FCC:</b> ANSI C63.26-2015 5.5 Radiated emissions testing	<b>FCC:</b> Section 95.3379 (a) Section 2.1053 Section 2.1057	20.1 dB 132.0 MHz, Vertical, QP	Complied	Radiated
Frequency stability	<b>FCC:</b> ANSI C63.26-2015 5.6 Frequency stability testing	<b>FCC:</b> Section 95.3379 (b) Section 2.1055	See data.	Complied	Radiated

Note: UL Japan, Inc.'s EMI Work Procedures: Work Instructions-ULID-003591 and Work Instructions-ULID-003593.  
\* In case any questions arise about test procedure, ANSI C63.10-2013, ANSI C63.26-2015 and KDB653005 are also referred.

\*1) The test is not applicable since the EUT is not the device that is designed to be connected to the public utility (AC) power line.

#### **Supplied Voltage Information**

This EUT provides stable voltage constantly to RF Module regardless of input voltage.

#### **Antenna Information**

The antenna is not removable from the EUT.

### **3.3 Addition to standard**

No addition, exclusion nor deviation has been made from the standard.

### 3.4 Uncertainty

Measurement uncertainty is not taken into account when stating conformity with a specified requirement.  
Note: When margins obtained from test results are less than the measurement uncertainty, the test results may exceed the limit.

The following uncertainties have been calculated to provide a confidence level of 95 % using a coverage factor  $k = 2$ .

#### Radiated emission

Measurement distance	Frequency range	Unit	Calculated Uncertainty (+/-)
3 m	9 kHz to 30 MHz	dB	3.3
10 m		dB	3.1
3 m	30 MHz to 200 MHz	Horizontal	4.7
		Vertical	4.7
	200 MHz to 1000 MHz	Horizontal	4.8
		Vertical	6.0
10 m	30 MHz to 200 MHz	Horizontal	5.2
		Vertical	5.1
	200 MHz to 1000 MHz	Horizontal	5.2
		Vertical	5.2
3 m	1 GHz to 6 GHz	dB	5.0
	6 GHz to 18 GHz	dB	5.2
1 m	10 GHz to 18 GHz	dB	5.3
	18 GHz to 26.5 GHz	dB	5.2
	26.5 GHz to 40 GHz	dB	4.7
0.5 m	26.5 GHz to 40 GHz	dB	4.8
≥ 0.5 m	40 GHz to 50 GHz	dB	4.3
	50 GHz to 75 GHz	dB	5.9
	75 GHz to 110 GHz	dB	5.7
≥ 3.8 cm	110 GHz to 170 GHz	dB	5.8*
≥ 2.5 cm	170 GHz to 260 GHz	dB	5.2*

\*under consideration about Uncertainty for testing at 1 cm distance.

#### Radiated emission (with Block downconverter)

Measurement distance	Frequency range	Uncertainty (+/-)
≥ 0.5 m	75 GHz to 83 GHz	3.4 dB*

\* This value was used for 75 GHz to 83 GHz in this report.

### 3.5 Test Location

UL Japan, Inc. Ise EMC Lab.

4383-326 Asama-cho, Ise-shi, Mie-ken 516-0021 Japan

Telephone: +81-596-24-8999

A2LA Certificate Number: 5107.02 / FCC Test Firm Registration Number: 884919

ISED Lab Company Number: 2973C / CAB identifier: JP0002

Test site	Width x Depth x Height (m)	Size of reference ground plane (m) / horizontal conducting plane	Other rooms	Maximum measurement distance
No.1 semi-anechoic chamber	19.2 x 11.2 x 7.7	7.0 x 6.0	No.1 Power source room	10 m
No.2 semi-anechoic chamber	7.5 x 5.8 x 5.2	4.0 x 4.0	-	3 m
No.3 semi-anechoic chamber	12.0 x 8.5 x 5.9	6.8 x 5.75	No.3 Preparation room	3 m
No.3 shielded room	4.0 x 6.0 x 2.7	N/A	-	-
No.4 semi-anechoic chamber	12.0 x 8.5 x 5.9	6.8 x 5.75	No.4 Preparation room	3 m
No.4 shielded room	4.0 x 6.0 x 2.7	N/A	-	-
No.5 semi-anechoic chamber	6.0 x 6.0 x 3.9	6.0 x 6.0	-	-
No.5 measurement room	6.4 x 6.4 x 3.0	6.4 x 6.4	-	-
No.6 shielded room	4.0 x 4.5 x 2.7	4.0 x 4.5	-	-
No.6 measurement room	4.75 x 5.4 x 3.0	4.75 x 4.15	-	-
No.7 shielded room	4.7 x 7.5 x 2.7	4.7 x 7.5	-	-
No.8 measurement room	3.1 x 5.0 x 2.7	3.1 x 5.0	-	-
No.9 measurement room	8.8 x 4.6 x 2.8	2.4 x 2.4	-	-
No.10 shielded room	3.8 x 2.8 x 2.8	3.8 x 2.8	-	-
No.11 measurement room	4.0 x 3.4 x 2.5	N/A	-	-
No.12 measurement room	2.6 x 3.4 x 2.5	N/A	-	-
Large Chamber	16.9 x 22.1 x 10.17	16.9 x 22.1	-	10 m
Small Chamber	5.3 x 6.69 x 3.59	5.3 x 6.69	-	-

### 3.6 Test data, Test instruments, and Test set up

Refer to APPENDIX.



## SECTION 4: Operation of EUT during testing

### 4.1 Operating Mode(s)

Mode	Test Item
Transmitting mode (Tx) - Mode 1 <ul style="list-style-type: none"> <li>• FCM 1 Low (76.3 GHz)</li> <li>• FCM 1 Mid (76.5 GHz)</li> <li>• FCM 1 High (76.7 GHz)</li> <li>• FCM 2</li> </ul>	- Occupied bandwidth - Radiated Power
Transmitting mode (Tx) - Mode 1 <ul style="list-style-type: none"> <li>• FCM 1 Low (76.3 GHz)</li> <li>• FCM 2</li> </ul>	- Modulation characteristics
Transmitting mode (Tx) - Mode 2 <ul style="list-style-type: none"> <li>• FCM 1 Low (76.3 GHz)</li> <li>• FCM 1 Mid (76.5 GHz)</li> <li>• FCM 1 High (76.7 GHz)</li> <li>• FCM 2</li> </ul>	- Occupied bandwidth - Radiated Power
Transmitting mode (Tx) - Mode 2 <ul style="list-style-type: none"> <li>• FCM 1 Low (76.3 GHz)</li> <li>• FCM 2</li> </ul>	- Modulation characteristics
Transmitting mode (Tx) <sup>*1), *2)</sup> <ul style="list-style-type: none"> <li>• Tx_BIST1</li> <li>• Tx_BIST2</li> <li>• Tx_BIST3</li> </ul>	- Occupied bandwidth - Radiated Power - Modulation characteristics
Normal operating mode - Mode 1 - Mode 2	- Field strength of spurious radiation - Frequency Stability
<ul style="list-style-type: none"> <li>- In actual operation, there are FCM1, FCM2 and Tx_BIST modulation parts in sequence within one transmission burst.</li> <li>- First, the EUT transmits FCM1 modulation. (FCM1 is switched the transmission frequency band for each period at random.)</li> <li>- After that, FCM2 is transmitted immediately.</li> <li>- After FCM2 transmission, Tx BIST is transmitted immediately. (Tx_BIST is repeated in the order to Tx_BIST 1, Tx_BIST 2, and Tx_BIST 3 at every cycle.)</li> <li>- *1) Tx_BIST is common to Mode1 and Mode2.</li> <li>- *2) Tx_BIST transmits simultaneously in the following combinations:               <ul style="list-style-type: none"> <li>• Tx_BIST1: ch 1 &amp; ch 2</li> <li>• Tx_BIST2: ch 2 &amp; ch 3</li> <li>• Tx_BIST3: ch 3 &amp; ch 4</li> </ul> </li> </ul>	
*Power of the EUT was set by the software as follows; Power Setting: Mode 1: 29.61 dBm (EIRP) Mode 2: 23.21 dBm (EIRP) Software: mwr_gen7_0076_t8630_FRD_Bs_BCP_withDF (Date: 2024.04.10, Storage location: EUT memory)	
*This setting of software is the worst case. Any conditions under the normal use do not exceed the condition of setting. In addition, end users cannot change the settings of the output power of the product.	

## 4.2 Configuration and peripherals

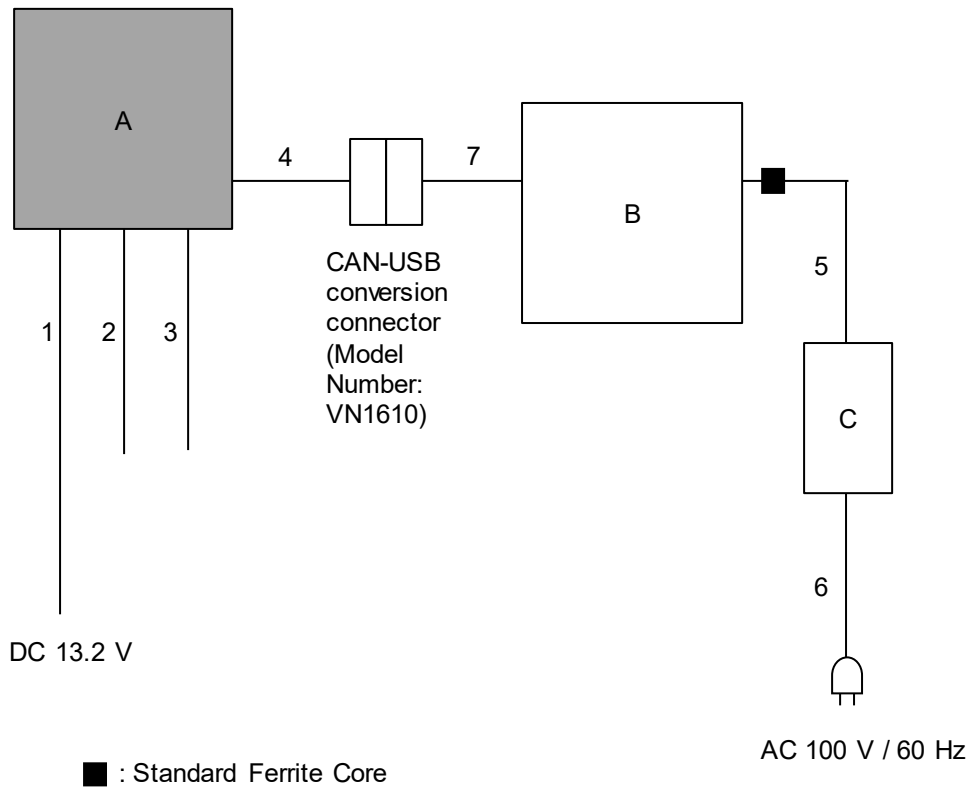

\* Cabling and setup(s) were taken into consideration and test data was taken under worse case conditions.  
\* The test voltage was referred to KDB653005 5.1(e) (FCC), and the test was performed with DC 13.2 V (1.1 times of nominal voltage DC 12 V).

### Description of EUT and Support equipment

No.	Item	Model number	Serial number	Manufacturer	Remarks
A	Millimeter Wave Radar Sensor	DNMWR018	B1T_2.1W1395	DENSO CORPORATION	EUT
B	Laptop PC	8265NGW	5CD922CPF	HP	-
C	AC Adapter	HSTNN-CA41	-	HP	-

### List of cables used

No.	Name	Length (m)	Shield		Remarks
			Cable	Connector	
1	DC Cable	5.0	Unshielded	Unshielded	-
2	Signal Cable	5.0	Unshielded	Unshielded	-
3	USB Cable	0.9	Shielded	Shielded	-
4	Can Cable	5.5	Unshielded	Unshielded	-
5	DC Cable	1.8	Unshielded	Unshielded	-
6	AC Cable	1.0	Unshielded	Unshielded	-
7	USB Cable	1.0	Shielded	Shielded	-

## **SECTION 5: Radiated Spurious Emission**

### **Test Procedure**

#### **[For below 30 MHz]**

The EUT was placed on a urethane platform of nominal size, 1.0 m by 1.5 m, raised 0.8 m above the conducting ground plane.

The Radiated Electric Field Strength has been measured in a Semi Anechoic Chamber with absorbent materials lined on a ground plane.

The loop antenna was fixed height at 1.0 m.

The EUT was rotated a full revolution in order to obtain the maximum value of the electric field intensity.

The measurements were performed for vertical polarization (antenna angle: 0 deg., 45 deg., 90 deg., 135 deg., and 180 deg.) and horizontal polarization.

\*Refer to Figure 1 about Direction of the Loop Antenna.

#### **[For above 30 MHz, up to 1 GHz]**

The EUT was placed on a urethane platform of nominal size, 1.0 m by 1.5 m, raised 0.8 m above the conducting ground plane. The Radiated Electric Field Strength has been measured in a Semi Anechoic Chamber with a ground plane.

The height of the measuring antenna varied between 1 m and 4 m and EUT was rotated a full revolution in order to obtain the maximum value of the electric field strength.

#### **[For above 1 GHz, up to 40 GHz]**

The EUT was placed on a urethane platform of nominal size, 1.0 m by 1.5 m, raised 1.5 m above the conducting ground plane.

The Radiated Electric Field Strength has been measured in a Semi Anechoic Chamber with absorbent materials lined on a ground plane.

The height of the measuring antenna varied between 1 m and 4 m and EUT was rotated a full revolution in order to obtain the maximum value of the electric field strength.

Test antenna was aimed at the EUT for receiving the maximum signal and always kept within the illumination area of the 3 dB beamwidth of the antenna.

The measurements were performed for both vertical and horizontal antenna polarization with the Test Receiver, or the Spectrum Analyzer.

The measurements were made with the following detector function of the test receiver and the Spectrum analyzer.

The test was made with the detector (RBW/VBW) in the following table.

#### **Test Antennas are used as below;**

Frequency	Below 30 MHz	30 MHz to 200 MHz	200 MHz to 1 GHz	Above 1 GHz
Antenna Type	Loop	Biconical	Logperiodic	Horn

Frequency	9 kHz to 150 kHz	150 kHz to 30 MHz	30 MHz to 1 GHz	1 GHz to 40 GHz
Instrument used	Test Receiver			Spectrum Analyzer
Detector	CISPR QP, Average	CISPR QP, Average	CISPR QP	Average *1)
IF Bandwidth	200 Hz	9 kHz	120 kHz	RBW: 1 MHz VBW: 3 MHz

\*1) A RMS average mode was applied according to KDB653005 4 (b) and 5.4 (f).

[Test setup]  
 Below 1 GHz

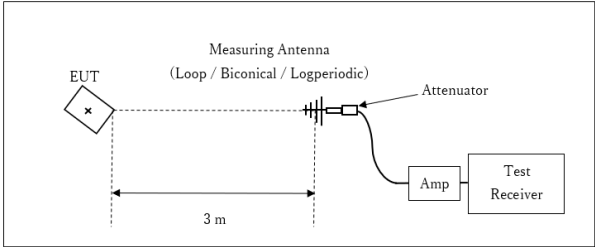

× : Center of turn table

Test Distance: 3 m

1 GHz to 10 GHz

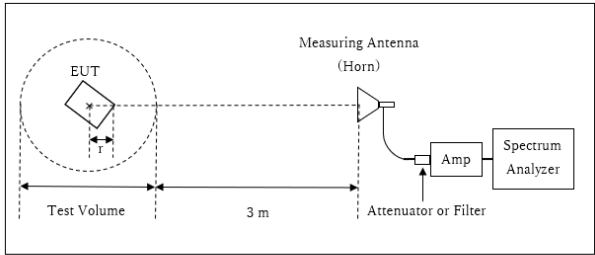

r : Radius of an outer periphery of EUT  
 × : Center of turn table

Distance Factor:  $20 \times \log(4.0 \text{ m}^*/3.0 \text{ m}) = 2.5 \text{ dB}$   
 \* Test Distance:  $(3 + \text{Test Volume} / 2) - r = 4.0 \text{ m}$

Test Volume: 2 m  
 (Test Volume has been calibrated based on CISPR 16-1-4.)  
 r = 0.0 m

\* The test was performed with r = 0.0 m since that yielded the worst emission levels from the EUT.

10 GHz to 40 GHz

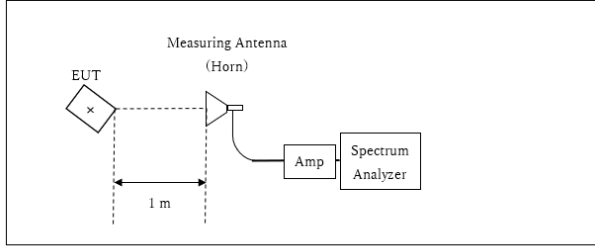

× : Center of turn table

Distance Factor:  $20 \times \log(1.0 \text{ m}^* / 3.0 \text{ m}) = -9.5 \text{ dB}$   
 \*Test Distance: 1 m

Figure 1: Direction of the Loop Antenna

Side View (Vertical)

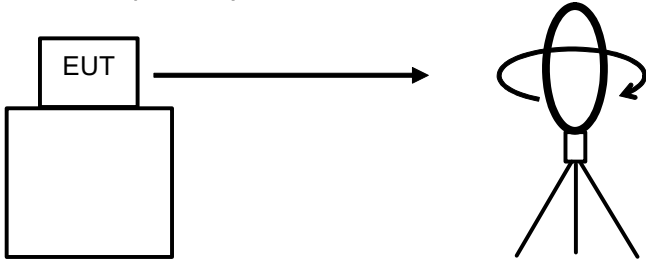

Top View (Horizontal)

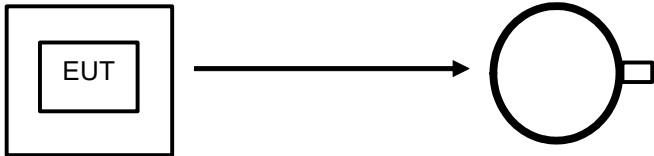

Antenna was not rotated.

Top View (Vertical)

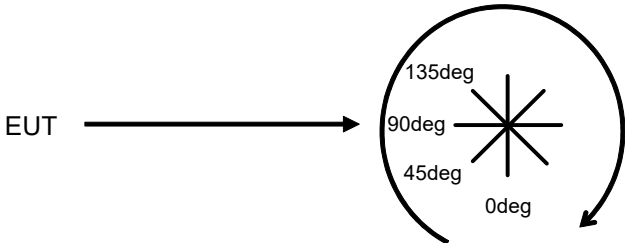

Front side: 0 deg.  
Forward direction: clockwise

**[Above 40 GHz (Expext for fundamental measurement)]**

The test was performed based on “Procedures for testing millimeter-wave systems” of ANSI C63.10-2013.

The EUT was placed on a urethane platform, raised 1.5 m above the conducting ground plane. The measurements were performed on handheld method.

Set spectrum analyzer RBW, VBW, span, etc., to the proper values. Note these values. Enable two traces—one set to “clear write,” and the other set to “max hold.” Begin hand-held measurements with the test antenna (horn) at a distance of 1 m from the EUT in a horizontally polarized position. Slowly adjust its position, entirely covering the plane 1 m from the EUT. Observation of the two active traces on the spectrum analyzer will allow refined horn positioning at the point(s) of maximum field intensity. Repeat with the horn in a vertically polarized position. If the emission cannot be detected at 1 m, reduce the RBW to increase system sensitivity. Note the value. If the emission still cannot be detected, move the horn closer to the EUT, noting the distance at which a measurement is made.

Note the maximum level indicated on the spectrum analyzer. Adjust this level, if necessary, by the antenna gain, filter loss, conversion loss of the external mixer and gain of LNA used, at the frequency under investigation. Calculate the field strength of the emission at the measurement distance from the Friis’ transmission equation.

The final test was performed with a 1 MHz RMS detctor at the following distances;

**[Test setup]**

40 GHz to 50 GHz

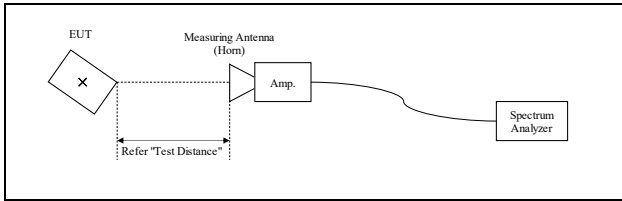

\*Test Distance: 1.0 m

Above 50 GHz

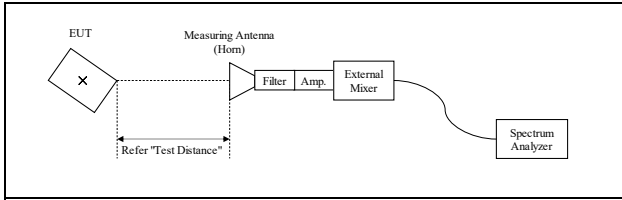

\*Test Distance:

50 GHz to 75 GHz	0.75 m
75 GHz to 110 GHz	0.50 m
110 GHz to 231 GHz	0.01 m

The test results and limit are rounded off to one decimal place, so some differences might be observed.

The noise levels were confirmed at each position of X, Y and Z axes of EUT to see the position of maximum noise, and the test was made at the position that has the maximum noise.

**[About fundamental measurement]**

The test was performed based on “Procedures for testing millimeter-wave systems” of ANSI C63.10-2013.

The EUT was placed on a urethane platform, raised 1.5 m above the conducting ground plane. The measurements were performed on handheld method.

The carrier levels were confirmed at maximum direction of transmission. The maximum direction was searched under carefully since beam-widths are extremely narrow.

The carrier levels were measured in the far field. The distance of the far field was calculated from follow equation.

$$r = \frac{2D^2}{\lambda}$$

where

*r* is the distance from the radiating element of the EUT to the edge of the far field, in m  
*D* is the largest dimension of both the radiating element and the test antenna (horn), in m  
 (The antenna aperture size of test antenna was used for this calculation.)  
*Lambda* is the wavelength of the emission under investigation [300/f (MHz)], in m

Frequency [GHz]	Wavelength <i>Lambda</i> [mm]	Maximum Dimension			Far Field Boundary <i>r</i> [m]	Tested Distance [m]
		EUT [m]	Test Antenna [m]	Maximum <i>D</i> [m]		
77	3.9	0.018560	0.026162	0.026162	0.352	0.5

In order to maximize the carrier level, the EUT, which has a horizontally polarized antenna, and the polarization plane of the measurement antenna were aligned for the test.

The Peak Power results was applied to the desensitization correction factor by KDB653005 4 (c) and 5.4 (d).

The derivation of the FMCW Desensitization Factor is given in Keysight Application Note 5952 1039 Appendix B.

Desensitization factor was calculated from follow equation;

$$\alpha = \frac{1}{\sqrt[4]{1 + \left(\frac{2\ln(2)}{\pi}\right)^2 \left(\frac{F_s}{T_s B^2}\right)^2}}$$

and

$$\text{FMCW Desensitization factor} = 20 \text{ Log } (\alpha)$$

Where

*F<sub>s</sub>* is FMCW Sweep Width or Chirp Width, is used the actual measurement value.

*T<sub>s</sub>* is FMCW Sweep Time, is referred to the values in the specifications.

*B* is -3dB Bandwidth of Gaussian RBW Filter, is used the actual measurement value.

Mode		$F_s$ [MHz]	$T_s$ [us]	$B$ [MHz]	$\alpha$	FMCW Desensitization factor [dB]
Mode 1	FCM 1 Low	375.6932	59.0	1.0	0.579	-4.75
	FCM 1 Mid	375.6517	59.0	1.0	0.579	-4.75
	FCM 1 High	374.3500	59.0	1.0	0.580	-4.73
	FCM 2	896.2804	38.0	1.0	0.309	-10.19
Mode 2	FCM 1 Low	375.5595	59.0	1.0	0.579	-4.74
	FCM 1 Mid	375.8317	59.0	1.0	0.579	-4.75
	FCM 1 High	375.0634	59.0	1.0	0.579	-4.74
	FCM 2	895.9744	38.0	1.0	0.309	-10.19

The test results and limit are rounded off to one decimal place, so some differences might be observed.

**Measurement range** : 9 kHz to 231 GHz  
**Test data** : APPENDIX  
**Test result** : Pass



## **SECTION 6: Frequency Stability**

### **Test Procedure**

The block downconverter was placed in side of the temperature chamber's drain hole.

The power supply was set to nominal operating voltage (110 %), and the spectrum mask was measured at 20 deg. C. After that, EUT power supply was varied between 85 % and 115 % of nominal voltage and the frequency excursion of the EUT emission mask was recorded.

The EUT operating temperature was raised to 50 deg. C, and the frequency excursion of the EUT emission mask was recorded. Measurements were repeated at each 10 deg. C decrement down to -20 deg. C.

Both lower and upper frequencies of the -20 dB Bandwidth were recorded.

**Test data** : APPENDIX  
**Test result** : Pass

**APPENDIX 1: Test data**

**Occupied bandwidth**

Test place	Ise EMC Lab.
Semi Anechoic Chamber	No. 3
Date	April 10, 2024
Temperature / Humidity	20 deg. C / 42 % RH
Engineer	Junki Nagatomi
Mode	Tx (Mode 1)

Mode	Frequency [GHz]	99 % Occupied bandwidth [MHz]
FCM 1 Low	76.3	375.6932
FCM 1 Mid	76.5	375.6517
FCM 1 High	76.7	374.3500
FCM 2	76.5	896.2804

**[Data]**

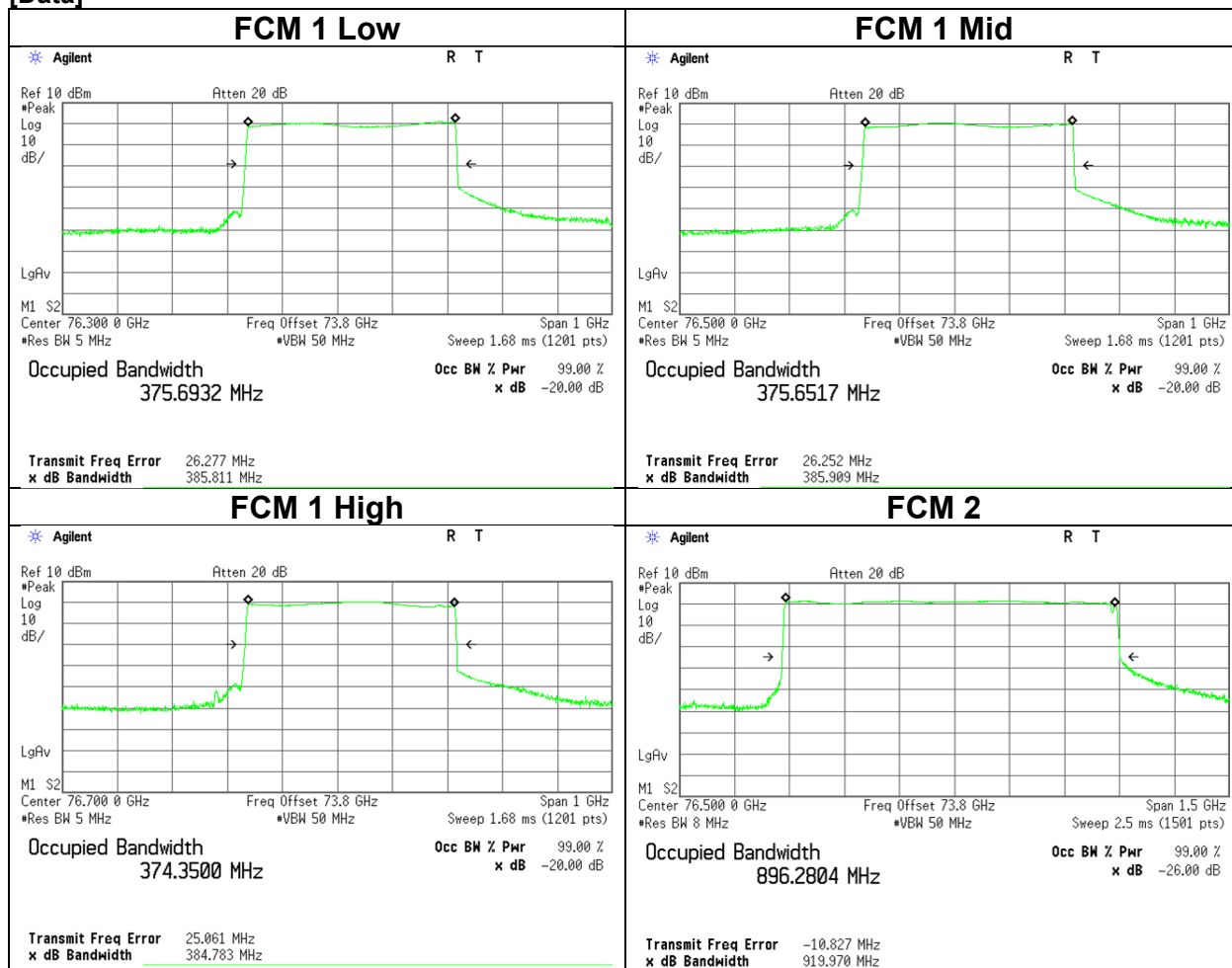

The measurement was performed with Peak detector and Max Hold since the duty cycle was not 100 %.

### Occupied bandwidth

Test place	Ise EMC Lab.
Semi Anechoic Chamber	No. 3
Date	April 10, 2024
Temperature / Humidity	20 deg. C / 42 % RH
Engineer	Junki Nagatomi
Mode	Tx (Mode 2)

Mode	Frequency [GHz]	99 % Occupied bandwidth [MHz]
FCM 1 Low	76.3	375.5595
FCM 1 Mid	76.5	375.8317
FCM 1 High	76.7	375.0634
FCM 2	76.5	895.9744

**[Data]**

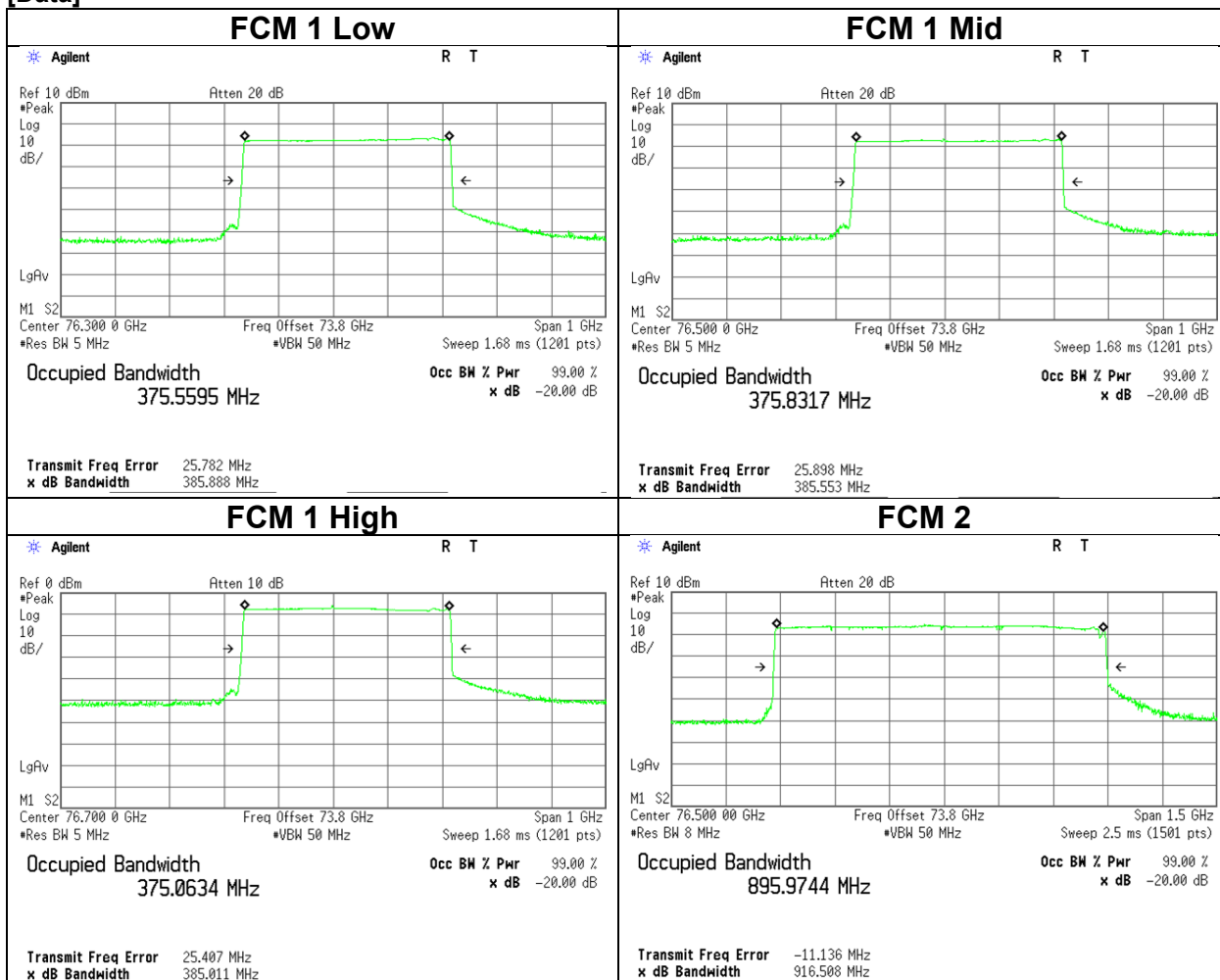

The measurement was performed with Peak detector and Max Hold since the duty cycle was not 100 %.

### Occupied bandwidth

Test place	Ise EMC Lab.
Semi Anechoic Chamber	No.4
Date	April 16, 2024
Temperature / Humidity	20 deg. C / 45 % RH
Engineer	Junki Nagatomi
Mode	Tx_BIST

Mode	Frequency [GHz]	99 % Occupied bandwidth [MHz]
Tx_BIST1	76.5	87.1314
Tx_BIST2	76.5	84.4732
Tx_BIST3	76.5	85.5746

**[Data]**

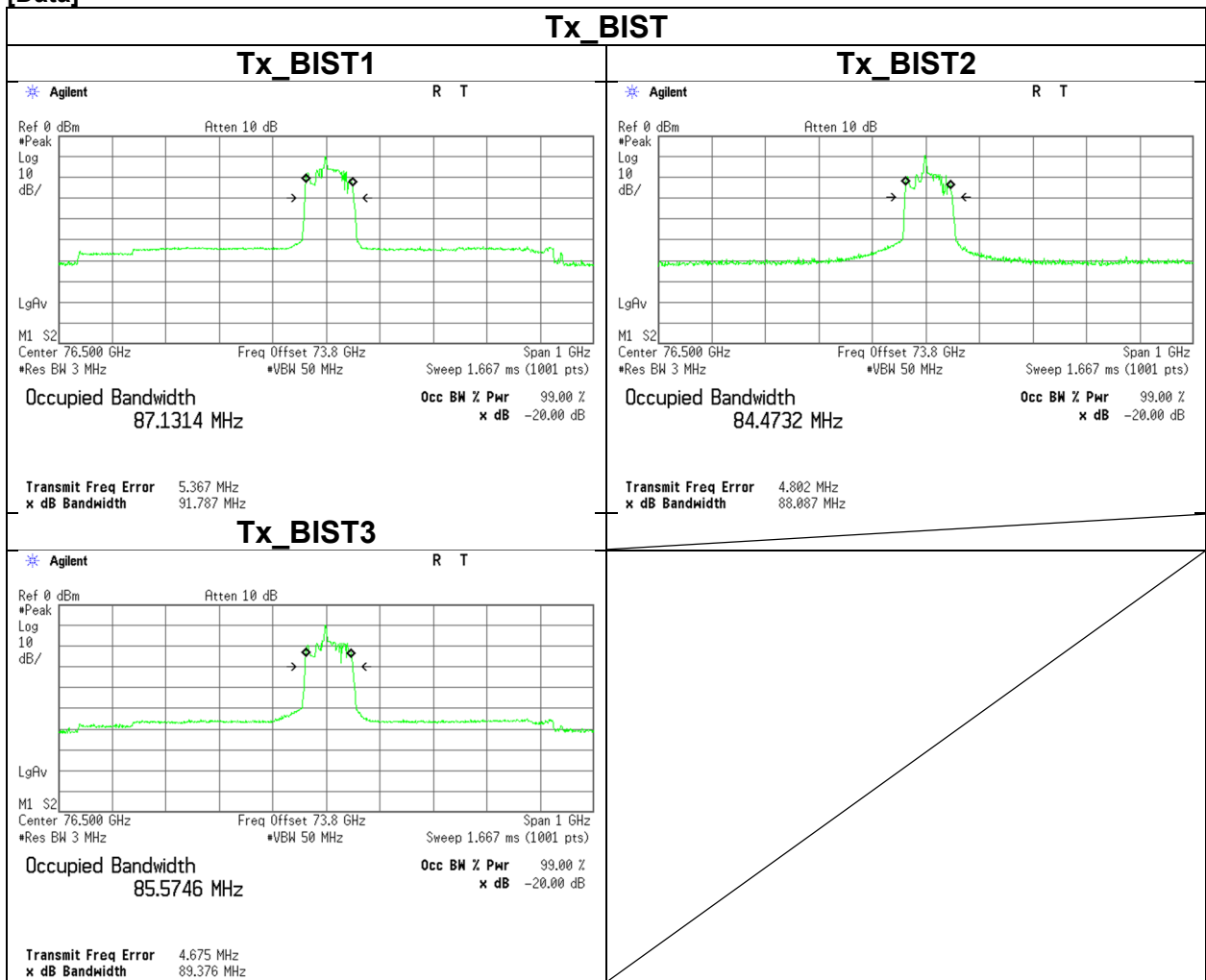

The measurement was performed with Peak detector and Max Hold since the duty cycle was not 100 %.

## Radiated Power

Test place	Ise EMC Lab.	
Semi Anechoic Chamber	No. 4	No. 4
Date	April 15, 2024	April 16, 2024
Temperature / Humidity	20 deg. C / 40 % RH	22 deg. C / 57 % RH
Engineer	Junki Nagatomi	Nachi Konegawa
Mode	Tx (Mode 1)	

Mode	Power	Freq.	Measured Power	Rx Ant. Gain	Down Converter Gain	IF Cable Loss	Tested Distance	FSL	Duty Factor	FMCW desensitization Factor	EIRP		Lmit	Margin	Remarks
		[GHz]	[dBm]	[dBi]	[dB]	[dB]	[m]	[dB]	[dB]	[dB]	[dBm]	[mW]	[dBm]	[dB]	
FCM 1 Low	Average	76.300	-8.73	23.05	15.04	1.66	0.5	64.07	5.01	-	23.92	246.60	50	26.08	
	Peak	76.299	-0.06	23.05	15.05	1.66	0.5	64.07	-	0.00	27.57	571.48	55	27.43	Marker 1 *1
	Peak	76.475	-1.46	23.05	15.01	1.65	0.5	64.09	-	0.00	26.22	418.79	55	28.78	Marker 2 *1
	Peak	76.511	-4.52	23.06	15.07	1.70	0.5	64.10	-	-4.75	27.89	615.18	55	27.11	Marker 3 *2
FCM 1 Mid	Peak	76.272	-5.02	23.05	15.09	1.65	0.5	64.07	-	-4.75	27.30	537.03	55	27.70	Marker 4 *2
	Average	76.500	-8.95	23.06	15.06	1.70	0.5	64.09	5.01	-	23.73	236.05	50	26.27	
	Peak	76.499	-0.29	23.06	15.05	1.70	0.5	64.09	-	0.00	27.39	548.28	55	27.61	Marker 1 *1
	Peak	76.675	-2.36	23.06	15.27	1.73	0.5	64.11	-	0.00	25.15	327.34	55	29.85	Marker 2 *1
FCM 1 High	Peak	76.713	-5.96	23.06	15.29	1.74	0.5	64.12	-	-4.75	26.29	425.60	55	28.71	Marker 3 *2
	Peak	76.488	-6.20	23.05	15.03	1.70	0.5	64.09	-	-4.75	26.26	422.67	55	28.74	Marker 4 *2
	Average	76.700	-9.03	23.06	15.29	1.73	0.5	64.12	5.01	-	23.48	222.84	50	26.52	
	Peak	76.699	-0.24	23.06	15.28	1.73	0.5	64.12	-	0.00	27.27	533.33	55	27.73	Marker 1 *1
FCM 2	Peak	76.875	-2.51	23.06	15.05	1.78	0.5	64.14	-	0.00	25.30	338.84	55	29.70	Marker 2 *1
	Peak	76.911	-5.63	23.06	14.91	1.80	0.5	64.14	-	-4.73	27.07	509.33	55	27.93	Marker 3 *2
	Peak	76.679	-5.49	23.06	15.27	1.73	0.5	64.11	-	-4.73	26.76	474.24	55	28.24	Marker 4 *2
	Average	76.500	-16.86	23.06	15.06	1.70	0.5	64.09	12.50	-	23.31	214.29	50	26.69	
FCM 2	Peak	76.449	-1.10	23.05	14.97	1.69	0.5	64.09	-	0.00	26.66	463.45	55	28.34	Marker 1 *1
	Peak	76.917	-1.61	23.06	14.89	1.80	0.5	64.14	-	0.00	26.38	434.51	55	28.62	Marker 2 *1
	Peak	76.938	-12.24	23.06	14.81	1.81	0.5	64.14	-	-10.19	26.04	401.79	55	28.96	Marker 3 *2
	Peak	76.040	-10.45	23.05	14.70	1.57	0.5	64.04	-	-10.19	27.61	576.77	55	27.39	Marker 4 *2

Calculating formula:

$$FSL \text{ (Free Space path Loss)} = 10 * \log_{10}((4 * \pi * \text{Tested Distance} / \text{Lambda})^2)$$

$$\text{Average EIRP} = \text{Measured Power} - \text{Rx Ant. Gain} - \text{Down Converter Gain} + \text{IF Cable Loss} + \text{FSL} + \text{Duty Factor}$$

$$\text{Peak EIRP} = \text{Measured Power} - \text{Rx Ant. Gain} - \text{Down Converter Gain} + \text{IF Cable Loss} + \text{FSL} - \text{FMCW desensitization factor}$$

\*1 For markers 1 and 2, the sensitivity correction coefficient was not applied based on the transmission pattern (duty in the “Operational Description-Duty Cycle”).

\*2 For markers 3 and 4, the sensitivity correction coefficient was applied based on the transmission pattern (duty in the “Operational Description-Duty Cycle”).

The test method referred to KDB653005 4 and 5.4.

The derivation of the Duty Factor is given in Duty data page.

The derivation of the FMCW Desensitization Factor is given in Keysight Application Note 5952 1039 Appendix B. (Refer Section 5)

### Radiated Power

[Data]

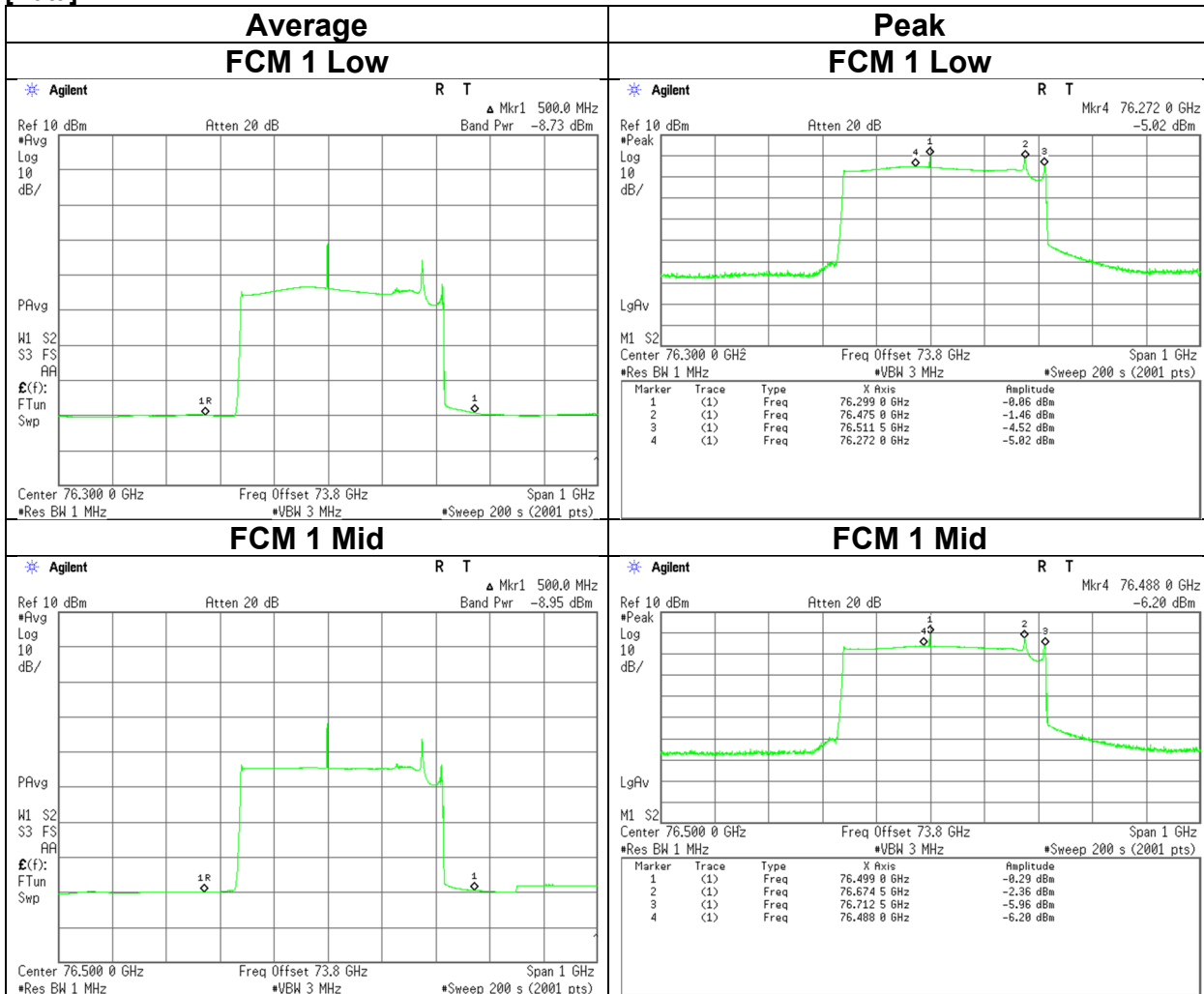

**Radiated Power**

[Data]

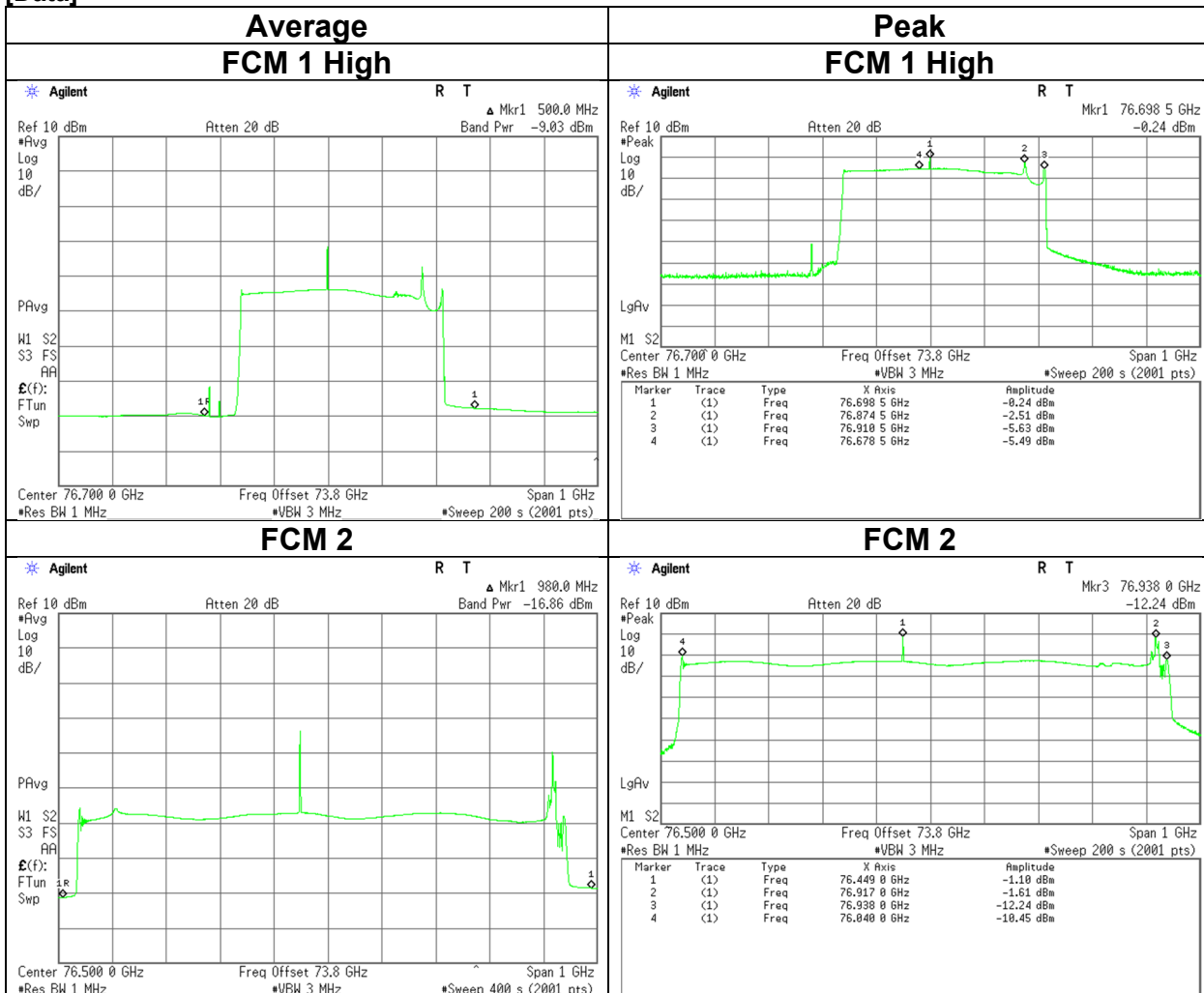

## Radiated Power

Test place	Ise EMC Lab.	
Semi Anechoic Chamber	No. 4	No. 4
Date	April 15, 2024	April 16, 2024
Temperature / Humidity	20 deg. C / 40 % RH	22 deg. C / 57 % RH
Engineer	Junki Nagatomi	Nachi Konegawa
Mode	Tx (Mode 2)	

Mode	Power	Freq.	Measured Power	Rx Ant. Gain	Down Converter Gain	IF Cable Loss	Tested Distance	FSL	Duty Factor	FMCW desensitization Factor	EIRP		Lmit	Margin	Remarks
		[GHz]	[dBm]	[dBi]	[dB]	[dB]	[m]	[dB]	[dB]	[dB]	[dBm]	[mW]	[dBm]	[dB]	
FCM 1 Low	Average	76.300	-15.97	23.05	15.04	1.66	0.5	64.07	5.02	-	16.69	46.67	50	33.31	
	Peak	76.299	-5.57	23.05	15.05	1.66	0.5	64.07	-	0.00	22.06	160.69	55	32.94	Marker 1 *1
	Peak	76.475	-8.03	23.05	15.01	1.69	0.5	64.09	-	0.00	19.69	93.11	55	35.31	Marker 2 *1
	Peak	76.511	-11.41	23.06	15.07	1.70	0.5	64.10	-	-4.74	21.00	125.89	55	34.00	Marker 3 *2
FCM 1 Mid	Peak	76.259	-11.83	23.05	15.11	1.65	0.5	64.07	-	-4.74	20.47	111.43	55	34.53	Marker 4 *2
	Average	76.500	-16.08	23.06	15.06	1.70	0.5	64.09	5.02	-	16.61	45.81	50	33.39	
	Peak	76.499	-5.66	23.06	15.05	1.70	0.5	64.09	-	0.00	22.02	159.22	55	32.98	Marker 1 *1
	Peak	76.675	-9.48	23.06	15.27	1.73	0.5	64.11	-	0.00	18.03	63.53	55	36.97	Marker 2 *1
FCM 1 High	Peak	76.710	-13.14	23.06	15.29	1.73	0.5	64.12	-	-4.75	19.11	81.47	55	35.89	Marker 3 *2
	Peak	76.481	-13.22	23.05	15.02	1.69	0.5	64.09	-	-4.75	19.24	83.95	55	35.76	Marker 4 *2
	Average	76.700	-16.16	23.06	15.29	1.73	0.5	64.12	5.02	-	16.36	43.25	50	33.64	
	Peak	76.699	-5.49	23.06	15.28	1.73	0.5	64.12	-	0.00	22.02	159.22	55	32.98	Marker 1 *1
FCM 2	Peak	76.875	-9.41	23.06	15.05	1.78	0.5	64.14	-	0.00	18.40	69.18	55	36.60	Marker 2 *1
	Peak	76.913	-12.56	23.06	14.91	1.80	0.5	64.14	-	-4.74	20.15	103.51	55	34.85	Marker 3 *2
	Peak	76.540	-12.77	23.06	15.13	1.71	0.5	64.10	-	-4.74	19.59	90.99	55	35.41	Marker 4 *2
	Average	76.500	-23.76	23.06	15.06	1.70	0.5	64.09	12.61	-	16.52	44.87	50	33.48	
FCM 2	Peak	76.449	-5.77	23.05	14.97	1.69	0.5	64.09	-	0.00	21.99	158.12	55	33.01	Marker 1 *1
	Peak	76.917	-8.79	23.06	14.89	1.80	0.5	64.14	-	0.00	19.20	83.18	55	35.80	Marker 2 *1
	Peak	76.938	-19.36	23.06	14.81	1.81	0.5	64.14	-	-10.19	18.92	77.98	55	36.08	Marker 3 *2
	Peak	76.040	-17.46	23.05	14.70	1.57	0.5	64.04	-	-10.19	20.59	114.55	55	34.41	Marker 4 *2

Calculating formula:

FSL (Free Space path Loss) =  $10 * \log_{10}((4 * \pi * \text{Tested Distance} / \text{Lambda})^2)$   
 Average EIRP = Measured Power - Rx Ant. Gain - Down Converter Gain + IF Cable Loss + FSL + Duty Factor  
 Peak EIRP = Measured Power - Rx Ant. Gain - Down Converter Gain + IF Cable Loss + FSL - FMCW desensitization factor

\*1 For markers 1 and 2, the sensitivity correction coefficient was not applied based on the transmission pattern (duty in the “Operational Description-Duty Cycle”).

\*2 For markers 3 and 4, a sensitivity correction coefficient was applied based on the transmission pattern (duty in the “Operational Description-Duty Cycle”).

The test method referred to KDB653005 4 and 5.4.

The derivation of the Duty Factor is given in Duty data page.

The derivation of the FMCW Desensitization Factor is given in Keysight Application Note 5952 1039 Appendix B. (Refer Section 5)



**Radiated Power**

[Data]

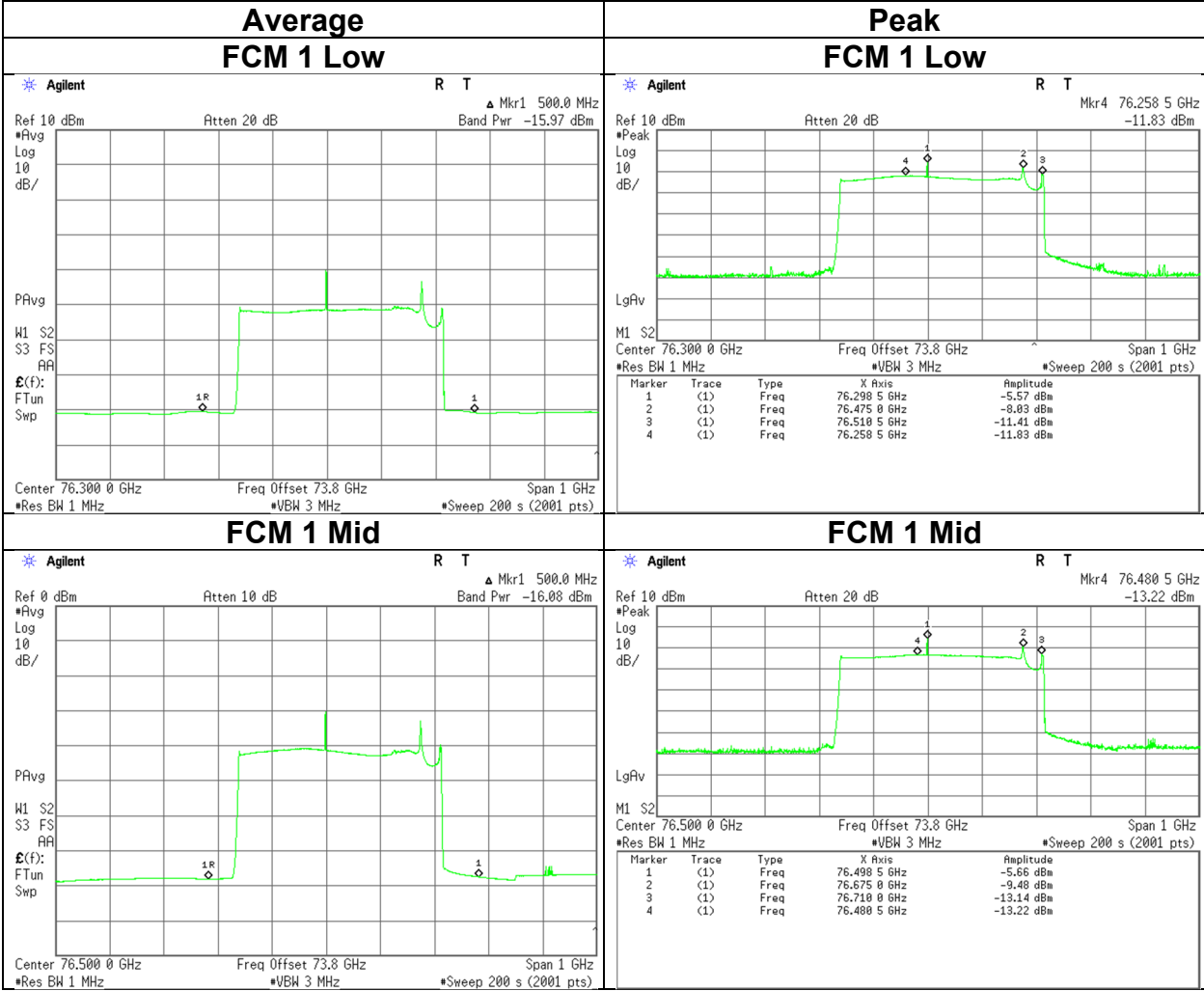

### Radiated Power

[Data]

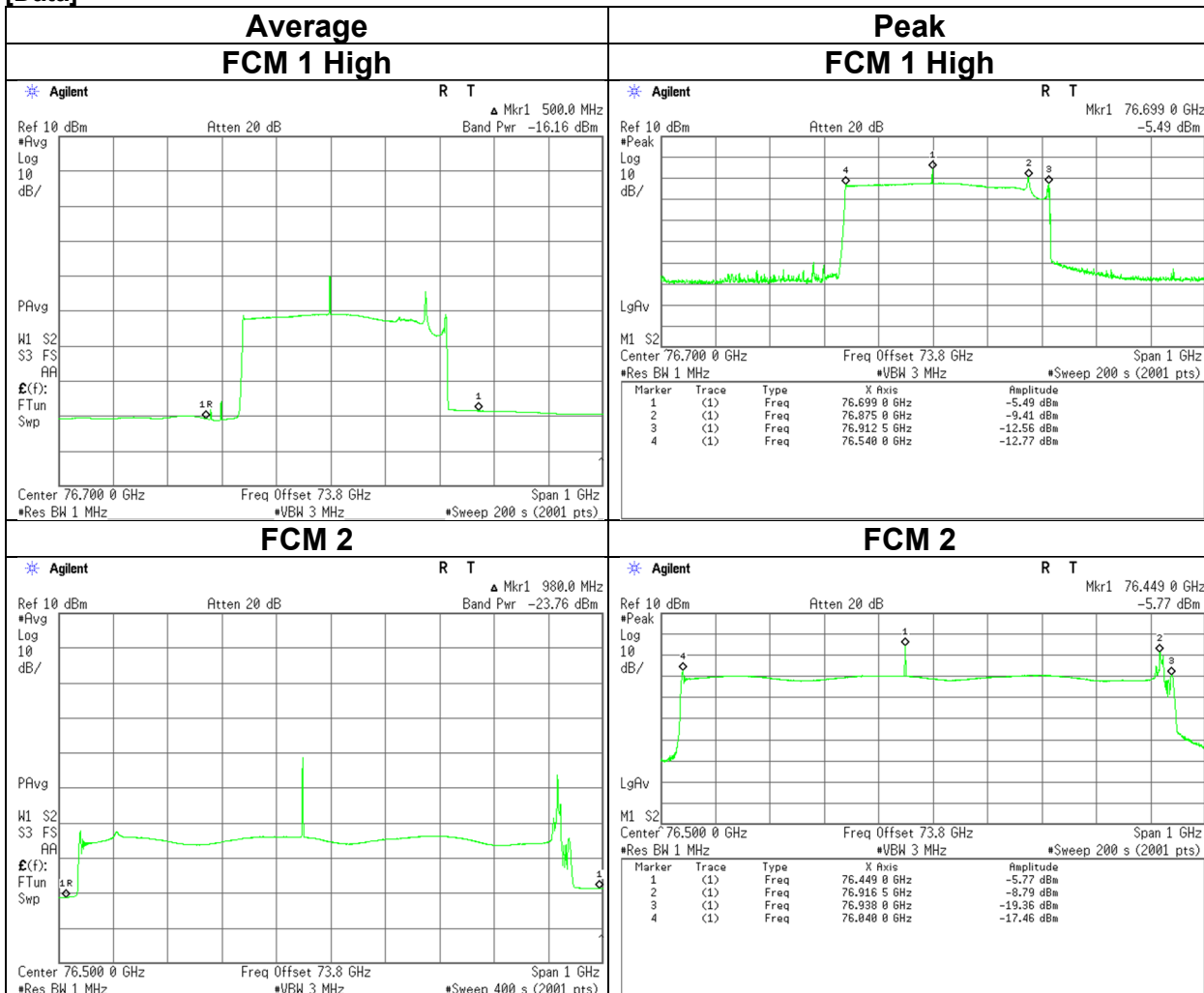

## Radiated Power

Test place	Ise EMC Lab.
Semi Anechoic Chamber	No.4
Date	April 16, 2024
Temperature / Humidity	20 deg. C / 45 % RH
Engineer	Junki Nagatomi
Mode	Tx_BIST

Mode	Power	Freq. [GHz]	Measured Power [dBm]	Rx Ant. Gain [dBi]	Down Converter Gain [dB]	IF Cable Loss [dB]	Tested Distance [m]	FSL [dB]	Duty Factor [dB]	FMCW desensitization Factor [dB]	ERP		Limit [dBm]	Margin [dB]	Remarks
											[dBm]	[mW]			
Tx_BIST1	Average	76.500	-36.58	23.06	15.06	1.70	0.5	64.09	20.93	-	12.02	15.92	50	37.98	
	Peak	76.499	-9.05	23.06	15.05	1.70	0.5	64.09	-	-	18.63	72.95	55	36.37	Marker 1 *1
	Peak	76.506	-21.96	23.06	15.07	1.70	0.5	64.10	-	-	5.71	3.72	55	49.29	Marker 2 *1
Tx_BIST2	Average	76.500	-37.89	23.06	15.06	1.70	0.5	64.09	20.93	-	10.71	11.78	50	39.29	
	Peak	76.499	-8.86	23.06	15.05	1.70	0.5	64.09	-	-	18.82	76.21	55	36.18	Marker 1 *1
	Peak	76.710	-34.95	23.06	15.29	1.73	0.5	64.12	-	-	-7.45	0.18	55	62.45	Marker 2 *1
Tx_BIST3	Average	76.500	-35.17	23.06	15.06	1.70	0.5	64.09	20.93	-	13.43	22.03	50	36.57	
	Peak	76.499	-9.03	23.06	15.05	1.70	0.5	64.09	-	-	18.65	73.28	55	36.35	Marker 1 *1
	Peak	76.513	-22.48	23.06	15.08	1.70	0.5	64.10	-	-	5.18	3.30	55	49.82	Marker 2 *1

Calculating formula:

FSL (Free Space path Loss) =  $10 * \log_{10}((4 * \pi * \text{Tested Distance} / \text{Lambda})^2)$   
Average ERP = Measured Power - Rx Ant. Gain - Down Converter Gain + IF Cable Loss + FSL + Duty Factor  
Peak ERP = Measured Power - Rx Ant. Gain - Down Converter Gain + IF Cable Loss + FSL - FMCW desensitization factor

\*1 For markers 1 and 2, the sensitivity correction coefficient was not applied based on the transmission pattern (duty in the “Operational Description-Duty Cycle”).

The test method referred to KDB653005 4 and 5.4.

The derivation of the Duty Factor is given in Duty data page.

The derivation of the FMCW Desensitization Factor is given in Keysight Application Note 5952 1039 Appendix B. (Refer Section 5)

### Radiated Power

[Data]

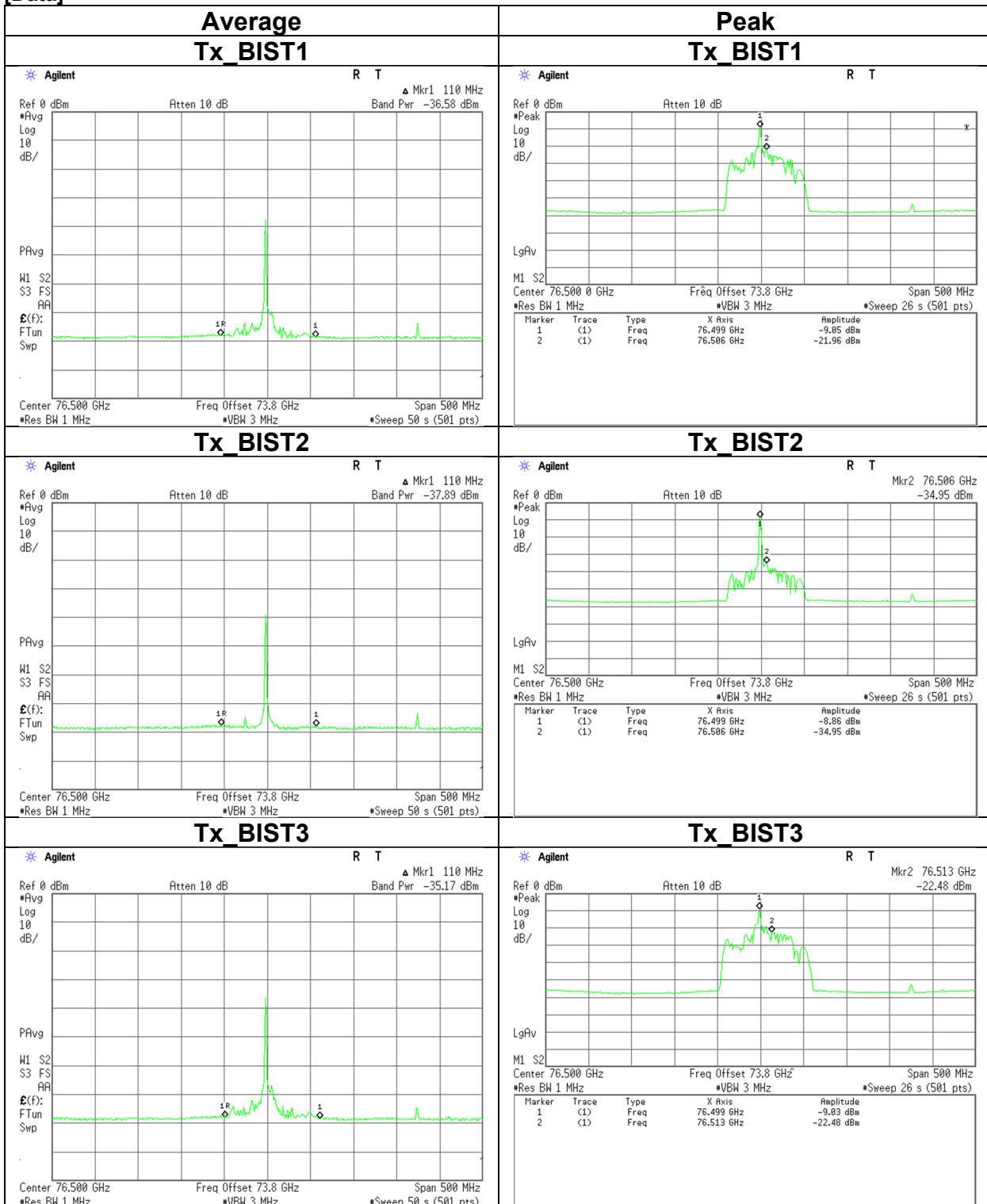

**Modulation characteristics**

Test place                    Ise EMC Lab.  
Semi Anechoic Chamber    No. 4  
Date                            May 11, 2024  
Temperature / Humidity    22 deg. C / 40 % RH  
Engineer                     Yuichiro Yamazaki  
Mode                          Tx (Mode 1) FCM 1 Low

Measured

Tx On time							FCM 1 section [ms]	Total [ms]	Tx On + Tx Off time [ms]	Duty [%]	Duty Factor [dB]
CW section											
(1 of 6) [us]	(2 of 6) [us]	(3 of 6) [us]	(4 of 6) [us]	(5 of 6) [us]	(6 of 6) [us]	(Total) [us]					
17.040	28.327	240.230	16.996	28.319	199.446	530.359	15.236	15.767	50.000	31.5	5.01

Calculating formula:

Tx On time CW section (Total) = Tx On time CW section (1 of 6) + Tx On time CW section (2 of 6) + Tx On time CW section (3 of 6) + Tx On time CW section (4 of 6) + Tx On time CW section (5 of 6) + Tx On time CW section (6 of 6)

Tx On time Total = Tx On time CW section (Total) + Tx On time FCM 1 section

Duty = (Tx On time Total / Tx On + Tx Off time) \* 100

Duty factor = 10 \* log (Tx On + Tx Off time / Tx On time Total)

[Data]

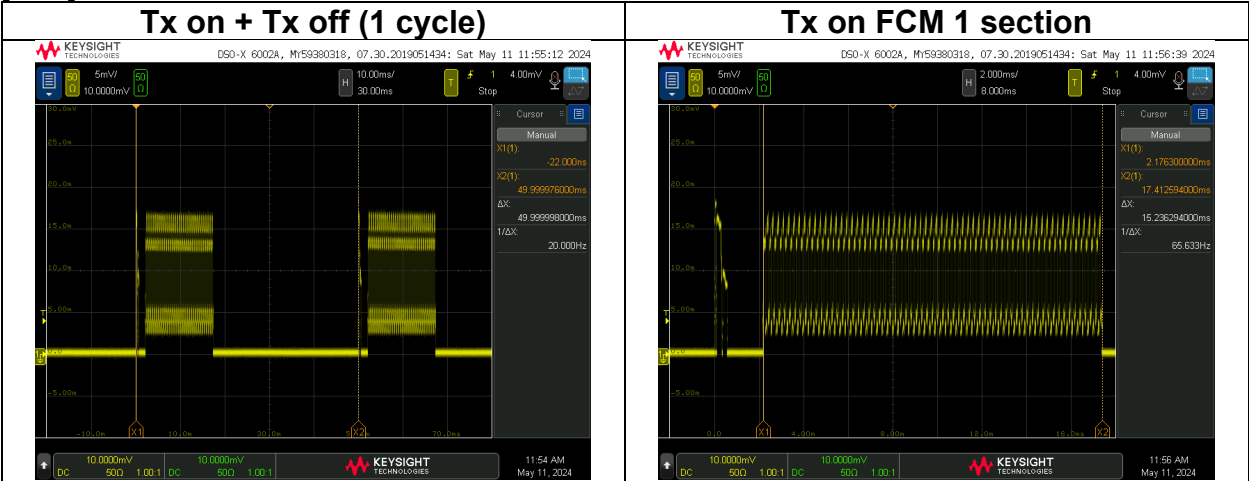

**Modulation characteristics**

[Data]

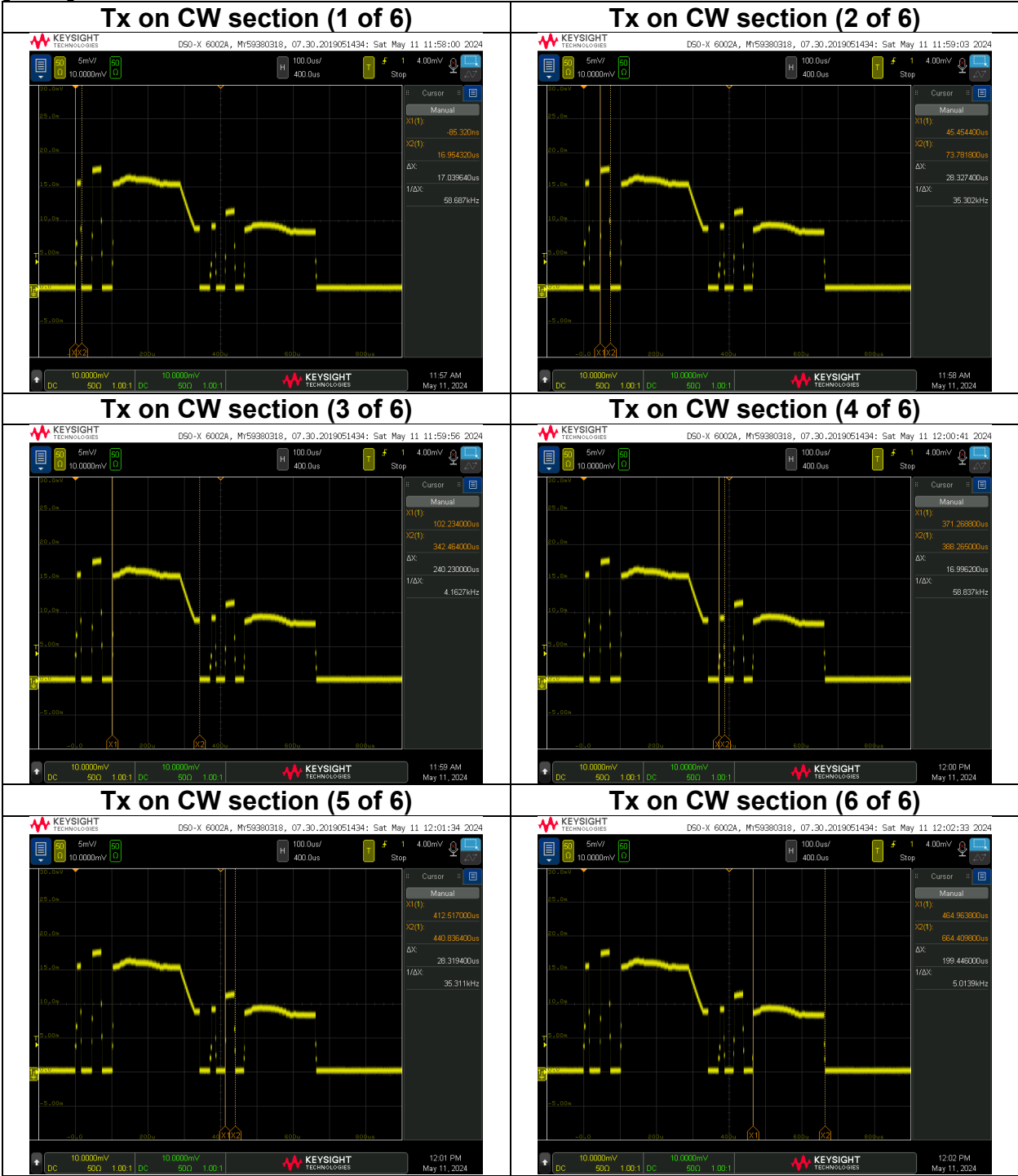

### Modulation characteristics

Test place                                    Ise EMC Lab.  
Semi Anechoic Chamber                No. 4  
Date    May 11, 2024  
Temperature / Humidity                22 deg. C / 40 % RH  
Engineer                                    Yuichiro Yamazaki  
Mode    Tx (Mode 1) FCM 2

Measured

Tx On time							FCM 2 section [ms]	Total [ms]	Tx On + Tx Off time [ms]	Duty [%]	Duty Factor [dB]
CW section											
(1 of 6) [us]	(2 of 6) [us]	(3 of 6) [us]	(4 of 6) [us]	(5 of 6) [us]	(6 of 6) [us]	(Total) [us]					
17.044	28.398	219.414	16.959	28.348	212.441	522.604	2.289	2.811	50.003	5.6	12.50

Calculating formula:

Tx On time CW section (Total) = Tx On time CW section (1 of 6) + Tx On time CW section (2 of 6) + Tx On time CW section (3 of 6) + Tx On time CW section (4 of 6) + Tx On time CW section (5 of 6) + Tx On time CW section (6 of 6)

Tx On time Total = Tx On time CW section (Total) + Tx On time FCM 2 section

Duty = (Tx On time Total / Tx On + Tx Off time) \* 100

Duty factor = 10 \* log (Tx On + Tx Off time / Tx On time Total)

[Data]

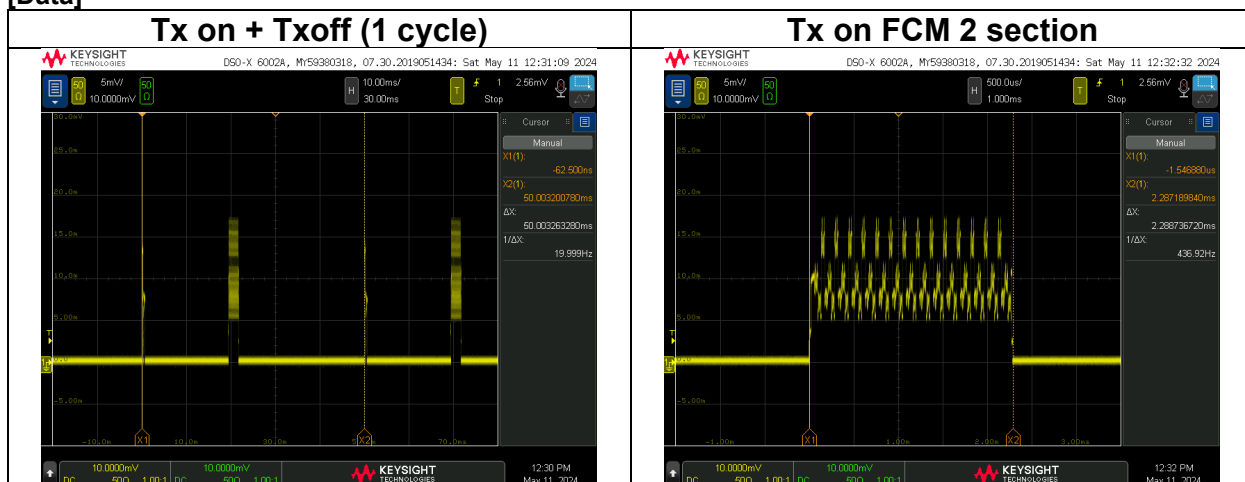

**Modulation characteristics**

[Data]

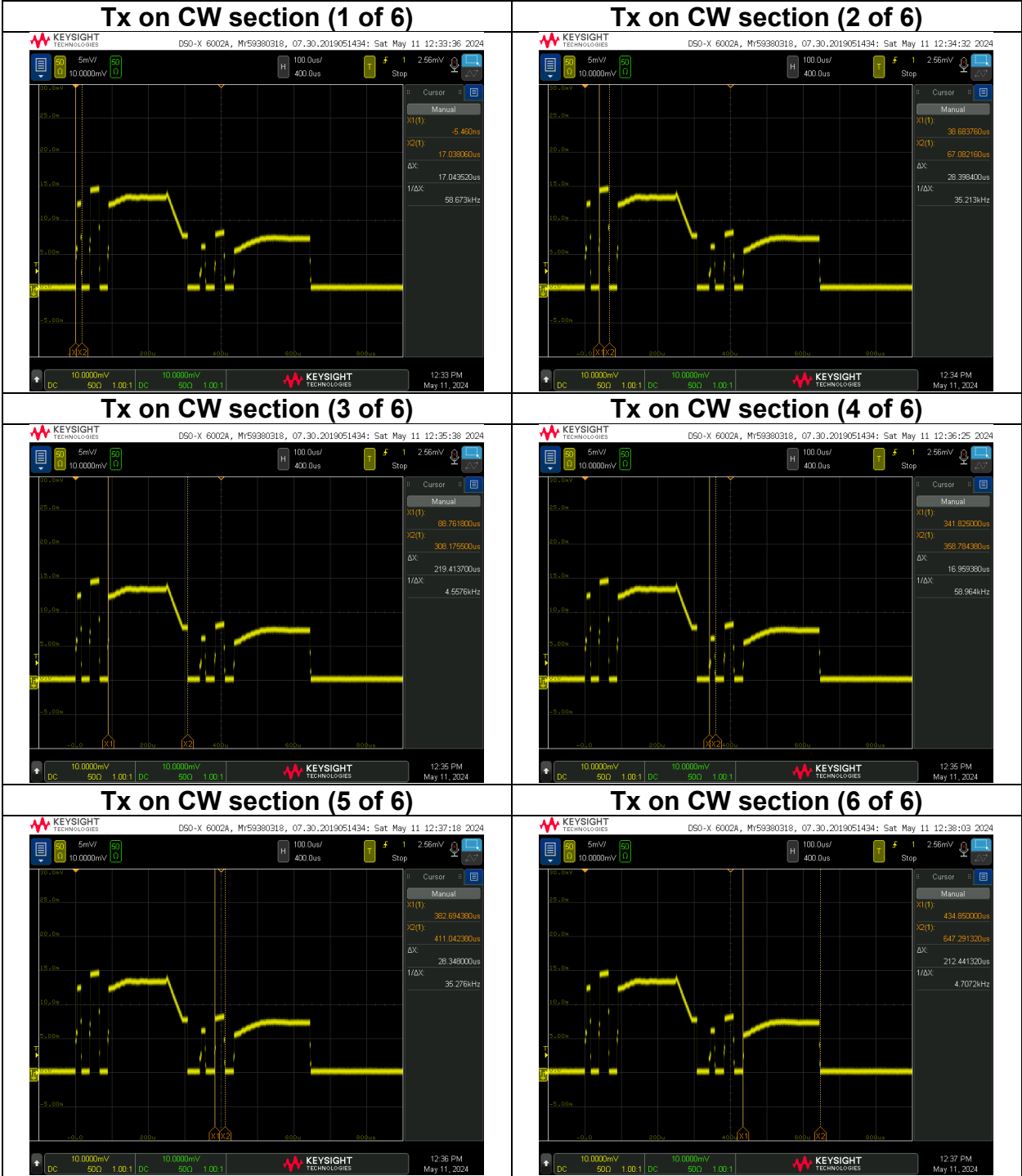



**Modulation characteristics**

Test place                                    Ise EMC Lab.  
 Semi Anechoic Chamber                No. 4  
 Date    May 11, 2024  
 Temperature / Humidity                22 deg. C / 40 % RH  
 Engineer                                    Yuichiro Yamazaki  
 Mode    Tx\_BIST

Measured

Tx On time		Total	Tx On + Tx Off time	Duty	Duty Factor
Tx_BIST1 Cal	Tx_BIST1				
[us]	[us]	[ms]	[ms]	[%]	[dB]
124.839	278.803	0.404	50.000	0.8	20.93

Calculating formula:  
 Tx On time Total = Tx On time Tx\_BIST1 Cal + Tx On time Tx\_BIST1  
 Duty = (Tx On time Total / Tx On + Tx Off time) \* 100  
 Duty factor = 10 \* log (Tx On + Tx Off time / Tx On time Total)

[Data]

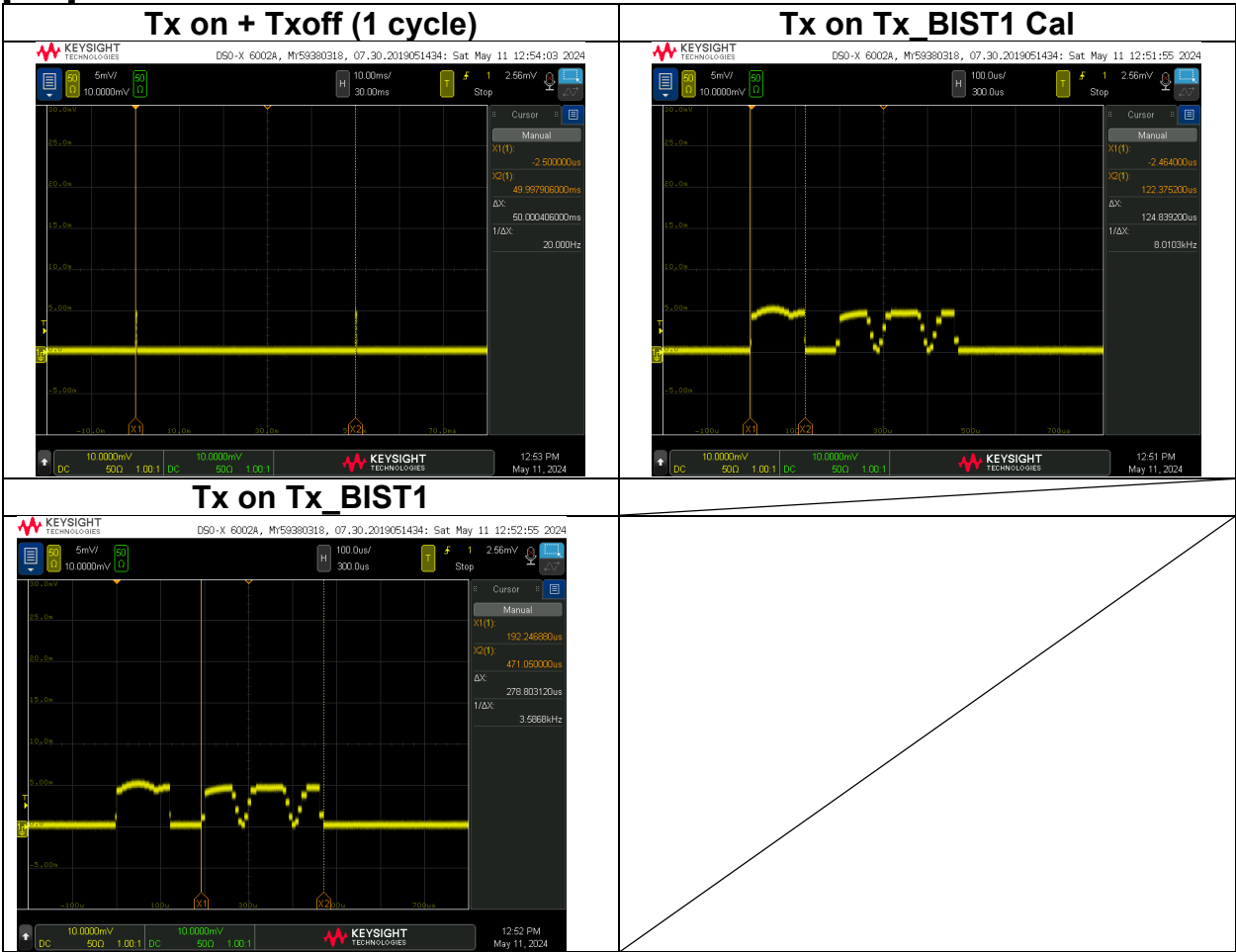

\* Since all Tx\_BIST transmission patterns are the same, the test was performed with Tx\_BIST1 as a representative.

**Modulation characteristics**

Test place                                    Ise EMC Lab.  
 Semi Anechoic Chamber                No. 4  
 Date    May 11, 2024  
 Temperature / Humidity                22 deg. C / 40 % RH  
 Engineer                                    Yuichiro Yamazaki  
 Mode    Tx (Mode 2) FCM 1 Low

Measured

Tx On time							FCM 1 section [ms]	Total [ms]	Tx On + Tx Off time [ms]	Duty [%]	Duty Factor [dB]
(1 of 6) [us]	(2 of 6) [us]	(3 of 6) [us]	(4 of 6) [us]	(5 of 6) [us]	(6 of 6) [us]	(Total) [us]					
17.042	28.313	251.422	16.876	28.272	151.160	493.085	15.235	15.728	50.001	31.5	5.02

Calculating formula:

Tx On time CW section (Total) = Tx On time CW section (1 of 6) + Tx On time CW section (2 of 6) + Tx On time CW section (3 of 6) + Tx On time CW section (4 of 6) + Tx On time CW section (5 of 6) + Tx On time CW section (6 of 6)  
 Tx On time Total = Tx On time CW section (Total) + Tx On time FCM 1 section  
 Duty = (Tx On time Total / Tx On + Tx Off time) \* 100  
 Duty factor = 10 \* log (Tx On + Tx Off time / Tx On time Total)

[Data]

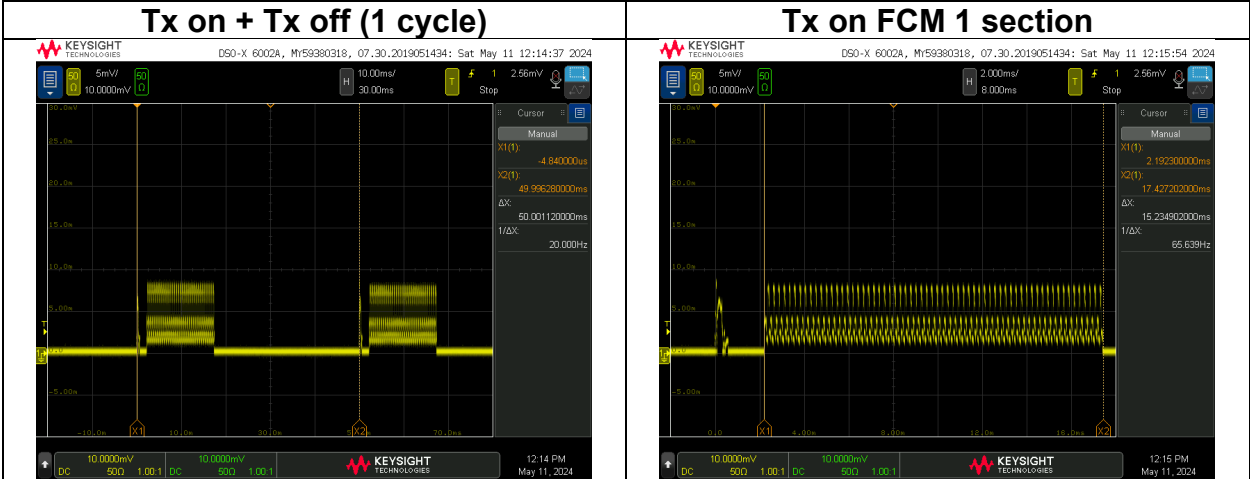

**Modulation characteristics**

[Data]

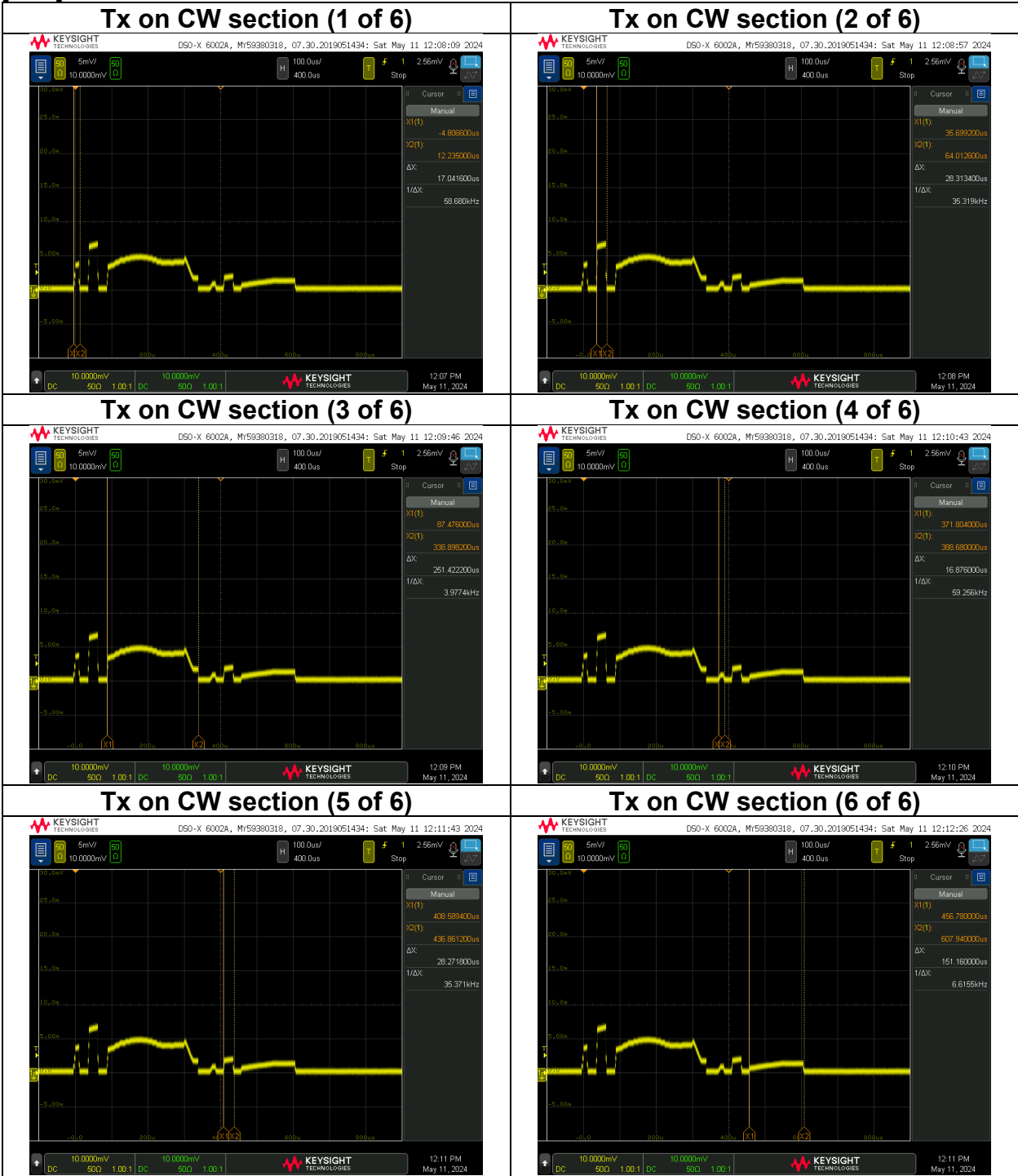

**Modulation characteristics**

Test place                    Ise EMC Lab.  
 Semi Anechoic Chamber    No. 4  
 Date                            May 11, 2024  
 Temperature / Humidity    22 deg. C / 40 % RH  
 Engineer                      Yuichiro Yamazaki  
 Mode                            Tx (Mode 2) FCM 2

Measured

Tx On time							FCM 2 section [ms]	Total [ms]	Tx On + Tx Off time [ms]	Duty [%]	Duty Factor [dB]
CW section											
(1 of 6) [us]	(2 of 6) [us]	(3 of 6) [us]	(4 of 6) [us]	(5 of 6) [us]	(6 of 6) [us]	(Total) [us]					
17.067	28.339	247.774	17.034	28.325	118.500	457.040	2.287	2.744	49.999	5.5	12.61

Calculating formula:

Tx On time CW section (Total) = Tx On time CW section (1 of 6) + Tx On time CW section (2 of 6) + Tx On time CW section (3 of 6) + Tx On time CW section (4 of 6) + Tx On time CW section (5 of 6) + Tx On time CW section (6 of 6)

Tx On time Total = Tx On time CW section (Total) + Tx On time FCM 2 section

Duty = (Tx On time Total / Tx On + Tx Off time) \* 100

Duty factor = 10 \* log (Tx On + Tx Off time / Tx On time Total)

[Data]

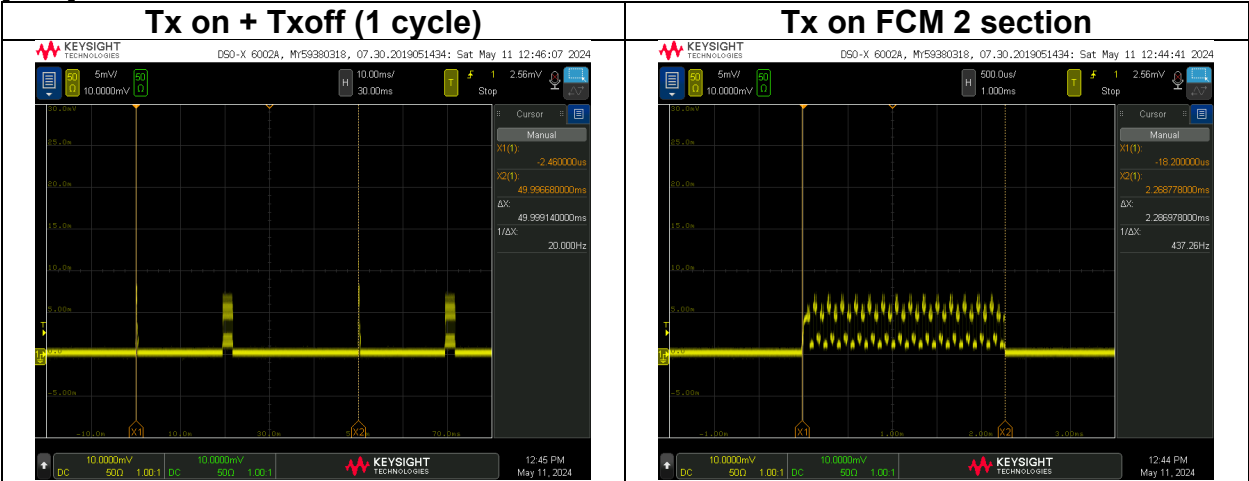

**Modulation characteristics**

[Data]

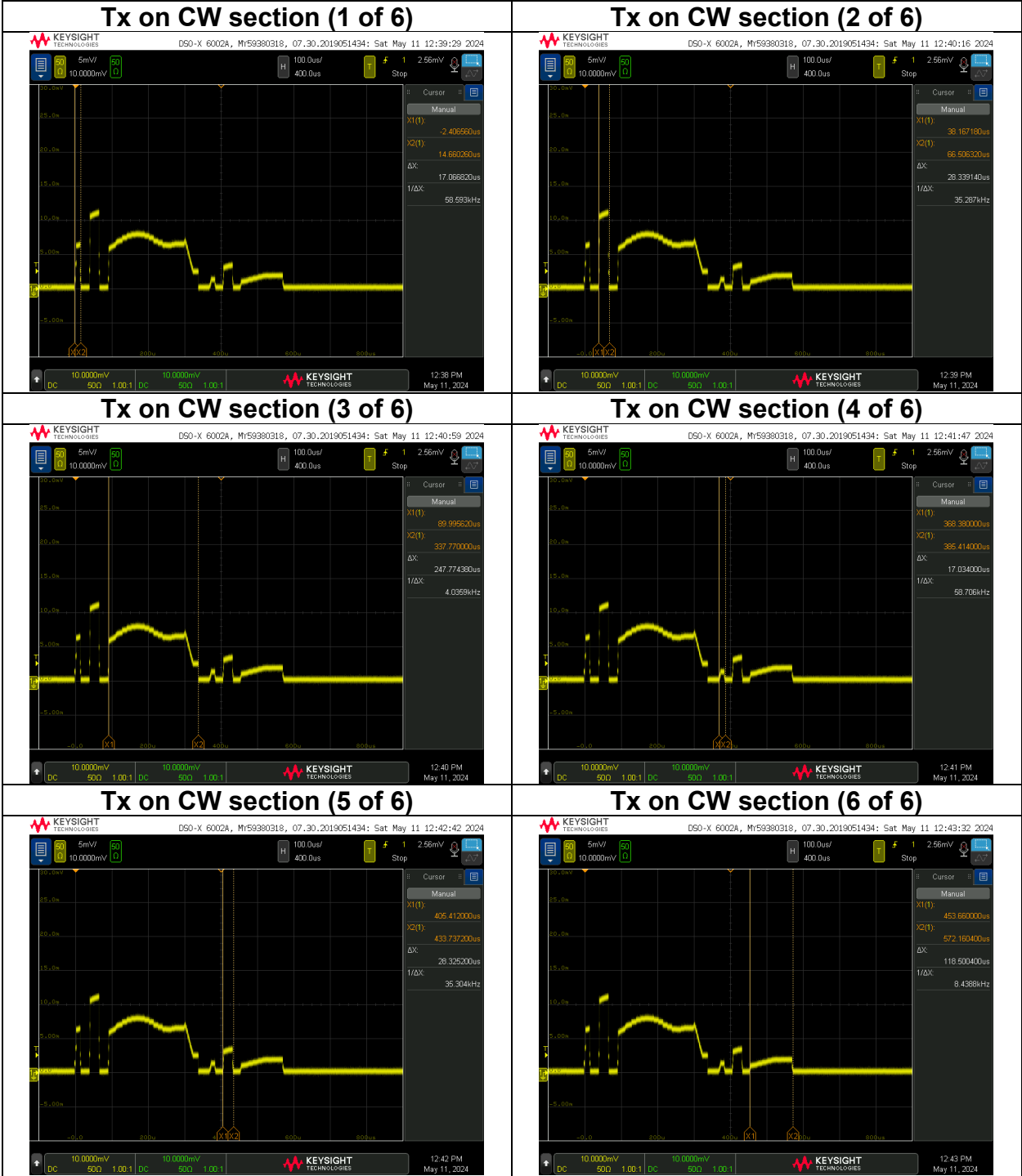

**Field strength of spurious radiation  
(Below 40 GHz)**

Test place	Ise EMC Lab.			
Semi Anechoic Chamber	No. 4	No. 4	No. 4	No. 4
Date	April 18, 2024	April 21, 2024	April 28, 2024	May 8, 2024
Temperature / Humidity	21 deg. C / 48 % RH	21 deg. C / 46 % RH	21 deg. C / 62 % RH	21 deg. C / 48 % RH
Engineer	Yuichiro Yamazaki	Yuichiro Yamazaki	Junki Nagatomi	Junki Nagatomi
	(9 kHz to 30 MHz)	(30 MHz to 1000 MHz)	(1 GHz to 18 GHz)	(18 GHz to 40 GHz)
Mode	Normal operating mode (Mode 1)			

Polarity	Frequency	Reading (QP / PK)	Reading (AV)	Ant. Factor	Loss	Gain	Result (QP / PK)	Result (AV)	Limit (QP / PK)	Limit (AV)	Margin (QP / PK)	Margin (AV)	Remark
[Hori/Vert]	[MHz]	[dBuV]	[dBuV]	[dB/m]	[dB]	[dB]	[dBuV/m]	[dBuV/m]	[dBuV/m]	[dBuV/m]	[dB]	[dB]	
Hori.	39.3	26.1	-	15.1	7.2	32.1	16.3	-	40.0	-	23.7	-	
Hori.	49.2	25.5	-	11.5	7.3	32.1	12.2	-	40.0	-	27.8	-	
Hori.	60.0	22.0	-	7.8	7.4	32.1	5.2	-	40.0	-	34.8	-	
Hori.	133.3	21.0	-	14.1	8.2	32.0	11.2	-	43.5	-	32.3	-	
Hori.	199.9	20.8	-	16.6	8.7	32.0	14.1	-	43.5	-	29.4	-	
Hori.	266.7	25.4	-	12.6	9.3	32.0	15.3	-	46.0	-	30.7	-	
Vert.	39.3	25.9	-	15.1	7.2	32.1	16.1	-	40.0	-	23.9	-	
Vert.	49.2	25.0	-	11.5	7.3	32.1	11.7	-	40.0	-	28.3	-	
Vert.	60.0	27.5	-	7.8	7.4	32.1	10.7	-	40.0	-	29.3	-	
Vert.	132.0	33.3	-	14.0	8.1	32.0	23.4	-	43.5	-	20.1	-	
Vert.	133.3	26.3	-	14.1	8.2	32.0	16.5	-	43.5	-	27.0	-	
Vert.	266.7	34.0	-	12.6	9.3	32.0	23.9	-	46.0	-	22.1	-	

Result = Reading + Ant Factor + Loss (Cable+Attenuator+Filter+Distance factor(above 1 GHz)) - Gain(Amplifier)

\*Other frequency noises omitted in this report were not seen or had enough margin (more than 20 dB).  
\*QP detector was used up to 1GHz.

Distance factor: 1 GHz - 10 GHz      20log (4.0 m / 3.0 m) = 2.5 dB  
10 GHz - 40 GHz      20log (1.0 m / 3.0 m) = -9.5 dB

**Field strength of spurious radiation**  
**(Below 40 GHz)**  
**(Plot data, Worst case)**

Test place	Ise EMC Lab.			
Semi Anechoic Chamber	No. 4	No. 4	No. 4	No. 4
Date	April 18, 2024	April 21, 2024	April 28, 2024	May 8, 2024
Temperature / Humidity	21 deg. C / 48 % RH	21 deg. C / 46 % RH	21 deg. C / 62 % RH	21 deg. C / 48 % RH
Engineer	Yuichiro Yamazaki (9 kHz to 30 MHz)	Yuichiro Yamazaki (30 MHz to 1000 MHz)	Junki Nagatomi (1 GHz to 18 GHz)	Junki Nagatomi (18 GHz to 40 GHz)
Mode	Normal operating mode (Mode 1)			

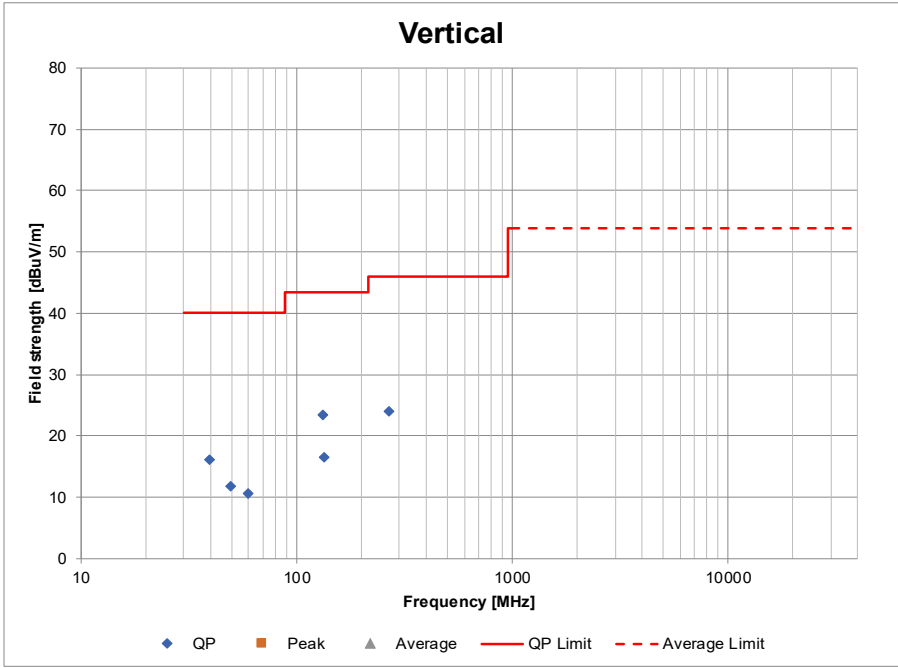
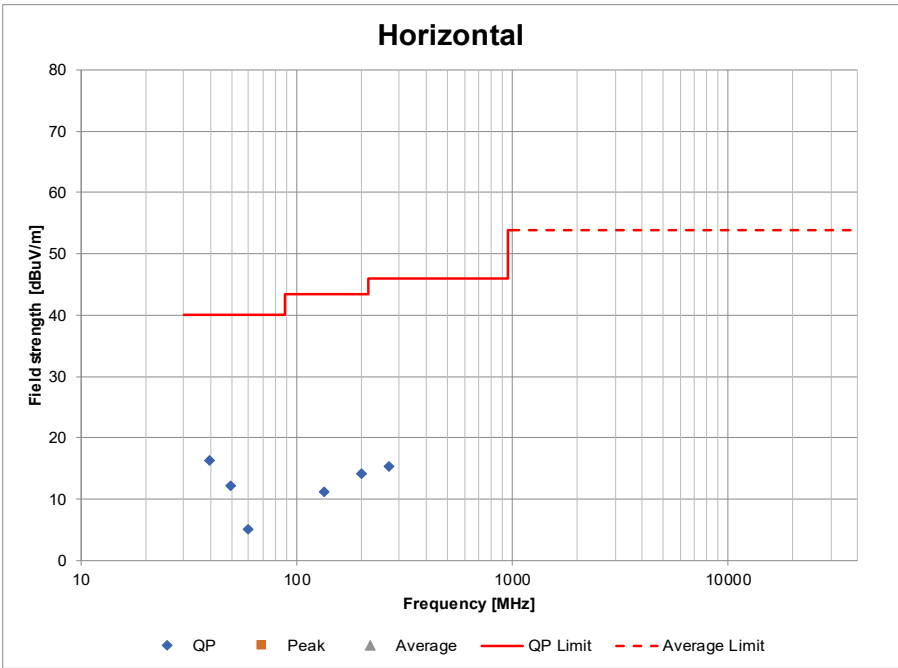

\*These plots data contains sufficient number to show the trend of characteristic features for EUT.

### Field strength of spurious radiation (Above 40 GHz)

Test place	Ise EMC Lab.	No. 4
Semi Anechoic Chamber	No. 4	April 24, 2024
Date	April 23, 2024	20 deg. C / 48 % RH
Temperature / Humidity	21 deg. C / 63 % RH	Junki Nagatomi
Engineer	Yuichiro Yamazaki	(Below 75 GHz, Above 170 GHz)
Mode	(75 GHz to 83 GHz, 110 GHz to 170 GHz)	Normal operating mode (Mode 1)

Frequency [GHz]	Reading [dBm]	Rx Ant. gain [dBi]	Filter loss [dB]	LNA gain [dB]	Mixer conversion loss [dB]	IF Amp. gain [dB]	IF Cable loss [dB]	Meas. range D [m]	FSL [dB]	EIRP		Power density at 3 m			Remarks
										[dBm]	[mW]	Result [pW/cm <sup>2</sup> ]	Limit [pW/cm <sup>2</sup> ]	Margin [dB]	
47.952	-58.62	22.21	0.00	32.80	0.00	0.00	8.67	1.00	66.06	-38.90	0.00013	0.11	600	37.22	NS
50.219	-74.73	22.88	0.37	26.10	48.25	32.04	0.10	0.75	63.96	-43.07	0.00005	0.04	600	41.38	NS
58.119	-74.70	23.59	0.26	25.79	45.85	32.04	0.10	0.75	65.23	-44.68	0.00003	0.03	600	43.00	NS
65.041	-80.00	24.09	0.30	23.33	47.58	32.04	0.10	0.75	66.21	-45.27	0.00003	0.03	600	43.59	NS
71.148	-76.14	24.39	0.49	20.73	49.19	32.04	0.10	0.75	66.99	-36.53	0.00022	0.20	600	34.85	NS
74.072	-75.73	24.47	1.12	20.88	49.96	32.04	0.10	0.75	67.34	-34.60	0.00035	0.31	600	32.92	NS
75.819	-75.38	23.03	0.00	0.00	-15.01	0.00	1.48	0.50	64.02	-47.92	0.00002	0.01	600	46.24	Average detected
81.701	-76.59	23.46	0.00	0.00	-12.58	0.00	2.91	0.50	64.67	-45.05	0.00003	0.03	600	43.37	NS
87.657	-57.90	23.85	0.71	32.33	0.00	0.00	0.00	0.50	65.28	-48.09	0.00002	0.01	600	46.41	NS
98.767	-48.33	24.38	0.46	34.52	0.00	0.00	0.00	0.50	66.31	-40.45	0.00009	0.08	600	38.77	NS
104.095	-48.53	24.66	0.42	30.62	0.00	0.00	0.00	0.50	66.77	-36.62	0.00022	0.19	600	34.94	NS
117.498	-87.51	22.55	0.00	18.24	53.96	0.00	0.00	0.01	33.84	-40.50	0.00009	0.08	600	38.82	NS
120.184	-87.55	22.65	0.00	18.61	50.37	0.00	0.00	0.01	34.04	-44.40	0.00004	0.03	600	42.72	NS
128.273	-87.75	22.90	0.00	20.50	50.40	0.00	0.00	0.01	34.60	-46.15	0.00002	0.02	600	44.47	NS
138.431	-89.52	23.15	0.00	19.20	51.51	0.00	0.00	0.01	35.27	-45.09	0.00003	0.03	600	43.41	NS
142.127	-90.19	23.22	0.00	18.71	52.87	0.00	0.00	0.01	35.50	-43.75	0.00004	0.04	600	42.07	NS
151.737	-91.40	23.34	0.00	17.46	55.24	0.00	0.00	0.01	36.06	-40.90	0.00008	0.07	600	39.22	NS
157.226	-92.31	23.38	0.00	17.34	57.12	0.00	0.00	0.01	36.37	-39.54	0.00011	0.10	600	37.86	NS
162.155	-92.81	23.40	0.00	15.46	57.73	0.00	0.00	0.01	36.64	-37.30	0.00019	0.16	600	35.62	NS
175.642	-89.48	22.53	0.00	0.00	58.29	0.00	0.00	0.01	37.33	-16.38	0.02301	20.34	600	14.70	NS
178.442	-90.52	22.60	0.00	0.00	57.07	0.00	0.00	0.01	37.47	-18.58	0.01387	12.27	600	16.89	NS
192.380	-90.72	22.89	0.00	0.00	56.46	0.00	0.00	0.01	38.12	-19.03	0.01251	11.06	600	17.34	NS
197.184	-92.68	22.97	0.00	0.00	57.20	0.00	0.00	0.01	38.34	-20.11	0.00974	8.61	600	18.43	NS
202.704	-91.82	23.06	0.00	0.00	56.58	0.00	0.00	0.01	38.58	-19.72	0.01066	9.43	1000	20.26	NS
208.023	-92.84	23.14	0.00	0.00	55.71	0.00	0.00	0.01	38.80	-21.47	0.00713	6.31	1000	22.00	NS
222.155	-93.79	23.29	0.00	0.00	62.22	0.00	0.00	0.01	39.37	-15.48	0.02831	25.03	1000	16.01	NS
227.649	-94.24	23.33	0.00	0.00	61.81	0.00	0.00	0.01	39.59	-16.18	0.02412	21.32	1000	16.71	NS

Calculation:

FSL (Free Space path Loss) =  $10 * \log ((4 * \text{Pi} * D / \lambda)^2)$

EIRP = Reading - Rx Ant. gain + Filter loss - LNA gain + Mixer conversion loss - IF Amp. gain + IF Cable loss + FSL

Power density Result at 3 m =  $\text{EIRP} / (4 * \text{Pi} * 300^2)$

These calculation results are same as results which were calculated with formulas described in the Section 9 of ANSI C63.10-2013.

- The equipment were not used for factor 0 dB of the data sheets.
- The Mixer conversion loss and IF Cable Loss are automatically corrected in the mixer, so the factor of data sheet were 0 dB.
- The IF Cable loss is included in Mixer loss, so the factor of data sheet were 0 dB.

NS: No signal detected.

#### Plot data, Worst case

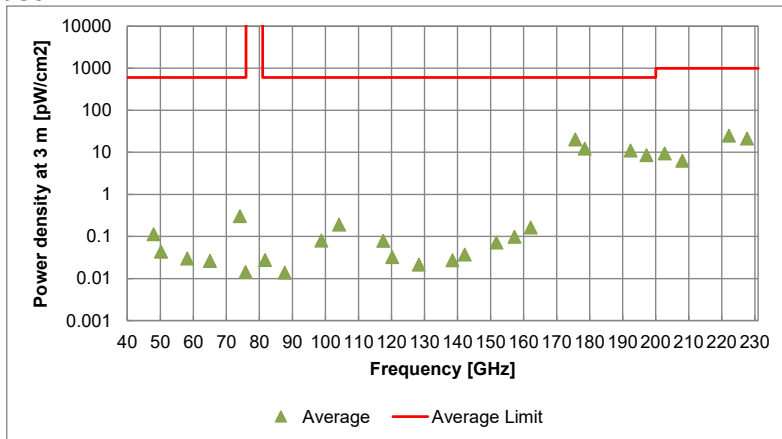

\*These plots data contains sufficient number to show the trend of characteristic features for EUT.



**Field strength of spurious radiation**  
**(Above 40 GHz)**  
(Data only for detected frequency)

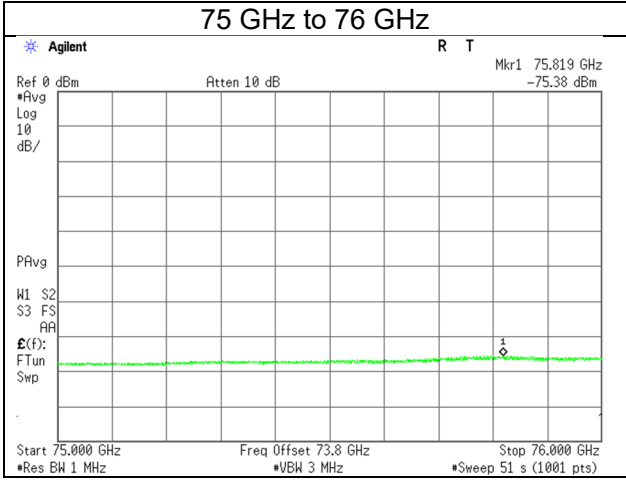

**Field strength of spurious radiation  
(Below 40 GHz)**

Test place	Ise EMC Lab.			
Semi Anechoic Chamber	No. 4	No. 4	No. 4	No. 4
Date	April 18, 2024	April 21, 2024	April 28, 2024	May 8, 2024
Temperature / Humidity	21 deg. C / 48 % RH	21 deg. C / 46 % RH	21 deg. C / 62 % RH	21 deg. C / 48 % RH
Engineer	Yuichiro Yamazaki	Yuichiro Yamazaki	Junki Nagatomi	Junki Nagatomi
	(9 kHz to 30 MHz)	(30 MHz to 1000 MHz)	(1 GHz to 18 GHz)	(18 GHz to 40 GHz)
Mode	Normal operating mode (Mode 2)			

Polarity	Frequency	Reading (QP / PK)	Reading (AV)	Ant. Factor	Loss	Gain	Result (QP / PK)	Result (AV)	Limit (QP / PK)	Limit (AV)	Margin (QP / PK)	Margin (AV)	Remark
[Hori/Vert]	[MHz]	[dBuV]	[dBuV]	[dB/m]	[dB]	[dB]	[dBuV/m]	[dBuV/m]	[dBuV/m]	[dBuV/m]	[dB]	[dB]	
Hori.	39.3	25.9	-	15.1	7.2	32.1	16.1	-	40.0	-	23.9	-	
Hori.	49.2	25.3	-	11.5	7.3	32.1	12.0	-	40.0	-	28.0	-	
Hori.	60.0	21.8	-	7.8	7.4	32.1	5.0	-	40.0	-	35.0	-	
Hori.	133.3	21.1	-	14.1	8.2	32.0	11.3	-	43.5	-	32.2	-	
Hori.	199.9	20.8	-	16.6	8.7	32.0	14.1	-	43.5	-	29.4	-	
Hori.	266.7	23.2	-	12.6	9.3	32.0	13.1	-	46.0	-	32.9	-	
Vert.	39.3	25.9	-	15.1	7.2	32.1	16.1	-	40.0	-	23.9	-	
Vert.	49.2	24.9	-	11.5	7.3	32.1	11.6	-	40.0	-	28.4	-	
Vert.	60.0	27.0	-	7.8	7.4	32.1	10.2	-	40.0	-	29.8	-	
Vert.	132.0	32.4	-	14.0	8.1	32.0	22.5	-	43.5	-	21.0	-	
Vert.	133.3	24.0	-	14.1	8.2	32.0	14.2	-	43.5	-	29.3	-	
Vert.	266.7	29.1	-	12.6	9.3	32.0	19.0	-	46.0	-	27.0	-	

Result = Reading + Ant Factor + Loss (Cable+Attenuator+Filter+Distance factor(above 1 GHz)) - Gain(Amplifier)

\*Other frequency noises omitted in this report were not seen or had enough margin (more than 20 dB).

\*QP detector was used up to 1GHz.

Distance factor:	1 GHz - 10 GHz	20log (4.0 m / 3.0 m) = 2.5 dB
	10 GHz - 40 GHz	20log (1.0 m / 3.0 m) = -9.5 dB

**Field strength of spurious radiation**  
**(Below 40 GHz)**  
**(Plot data, Worst case)**

Test place	Ise EMC Lab.			
Semi Anechoic Chamber	No. 4	No. 4	No. 4	No. 4
Date	April 18, 2024	April 21, 2024	April 28, 2024	May 8, 2024
Temperature / Humidity	21 deg. C / 48 % RH	21 deg. C / 46 % RH	21 deg. C / 62 % RH	21 deg. C / 48 % RH
Engineer	Yuichiro Yamazaki (9 kHz to 30 MHz)	Yuichiro Yamazaki (30 MHz to 1000 MHz)	Junki Nagatomi (1 GHz to 18 GHz)	Junki Nagatomi (18 GHz to 40 GHz)
Mode	Normal operating mode (Mode 2)			

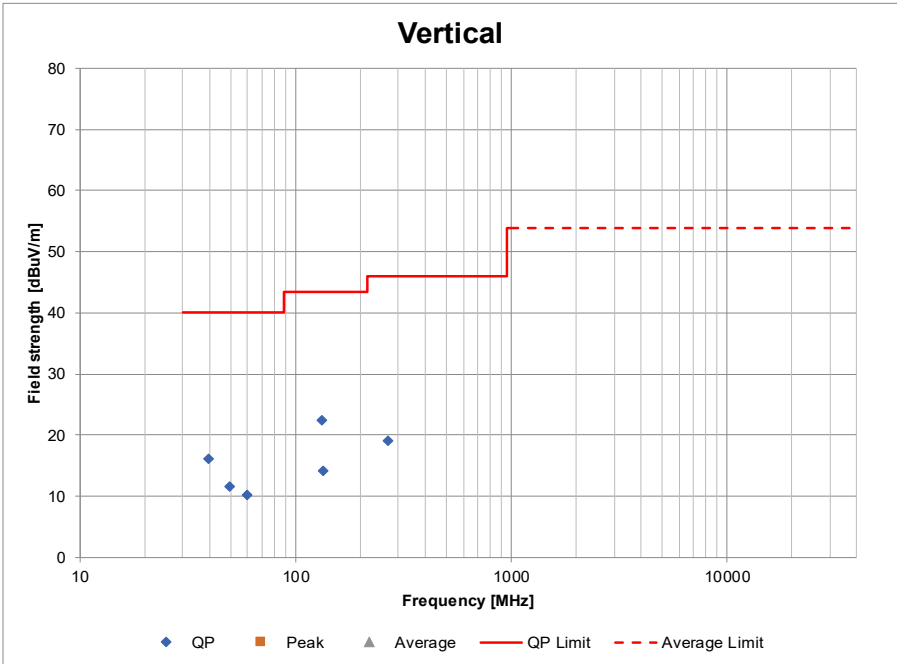
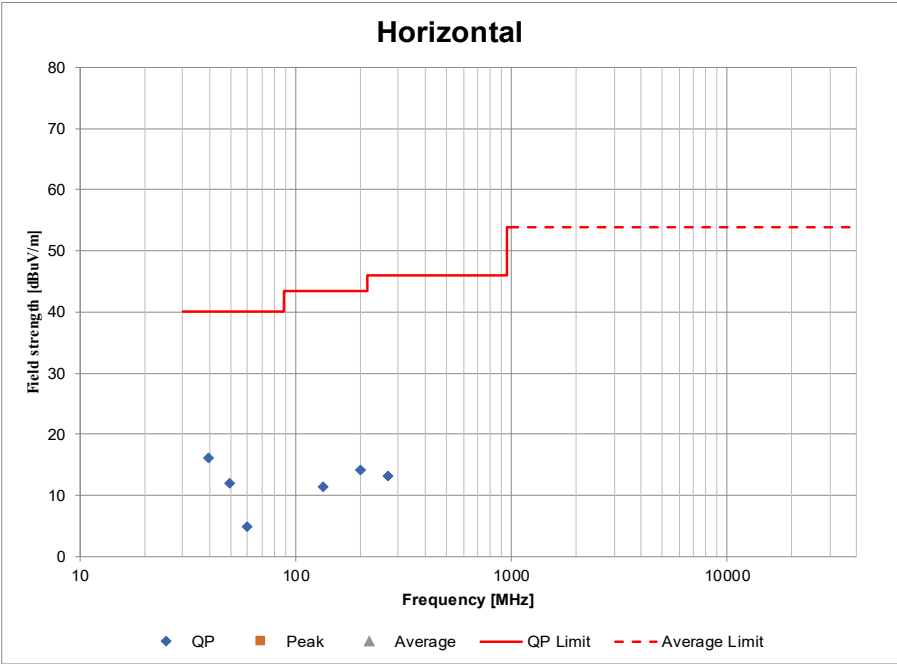

\*These plots data contains sufficient number to show the trend of characteristic features for EUT.

### Field strength of spurious radiation (Above 40 GHz)

Test place	Ise EMC Lab.	No. 4
Semi Anechoic Chamber	No. 4	April 24, 2024
Date	April 23, 2024	20 deg. C / 48 % RH
Temperature / Humidity	21 deg. C / 63 % RH	Junki Nagatomi
Engineer	Yuichiro Yamazaki	(Below 75 GHz, Above 170 GHz)
	(75 GHz to 83 GHz, 110 GHz to 170 GHz)	
Mode	Normal operating mode (Mode 2)	

Frequency [GHz]	Reading [dBm]	Rx Ant. gain [dBi]	Filter loss [dB]	LNA gain [dB]	Mixer conversion loss [dB]	IF Amp. gain [dB]	IF Cable loss [dB]	Meas. range D [m]	FSL [dB]	EIRP		Power density at 3 m			Remarks
										[dBm]	[mW]	Result [pW/cm <sup>2</sup> ]	Limit [pW/cm <sup>2</sup> ]	Margin [dB]	
48.733	-58.89	22.18	0.00	32.37	0.00	0.00	8.70	1.00	66.20	-38.54	0.00014	0.12	600	36.86	NS
50.538	-74.75	22.85	0.32	26.05	47.78	32.04	0.10	0.75	64.02	-43.47	0.00004	0.04	600	41.79	NS
61.250	-74.99	23.80	0.35	24.66	45.98	32.04	0.10	0.75	65.69	-43.38	0.00005	0.04	600	41.69	NS
67.013	-75.15	24.22	0.47	23.16	47.89	32.04	0.10	0.75	66.47	-39.64	0.00011	0.10	600	37.96	NS
71.680	-75.92	24.35	0.63	20.74	49.06	32.04	0.10	0.75	67.05	-36.20	0.00024	0.21	600	34.52	NS
74.148	-75.56	24.47	1.10	20.90	50.03	32.04	0.10	0.75	67.34	-34.39	0.00036	0.32	600	32.71	NS
75.834	-78.19	23.03	0.00	0.00	-14.98	0.00	1.48	0.50	64.02	-50.70	0.00001	0.01	600	49.02	Average detected
81.701	-76.61	23.46	0.00	0.00	-12.58	0.00	2.91	0.50	64.67	-45.08	0.00003	0.03	600	43.39	NS
84.852	-53.89	23.68	2.39	31.63	0.00	0.00	0.00	0.50	64.99	-41.81	0.00007	0.06	600	40.13	NS
99.419	-47.78	24.43	0.46	33.83	0.00	0.00	0.00	0.50	66.37	-39.21	0.00012	0.11	600	37.53	NS
102.030	-49.39	24.49	0.36	32.69	0.00	0.00	0.00	0.50	66.60	-39.62	0.00011	0.10	600	37.93	NS
116.597	-87.61	22.52	0.00	17.40	54.47	0.00	0.00	0.01	33.78	-39.29	0.00012	0.10	600	37.60	NS
118.097	-87.56	22.57	0.00	18.62	54.10	0.00	0.00	0.01	33.89	-40.77	0.00008	0.07	600	39.08	NS
128.025	-87.96	22.89	0.00	20.66	49.74	0.00	0.00	0.01	34.59	-47.19	0.00002	0.02	600	45.50	NS
138.515	-89.66	23.16	0.00	19.21	51.48	0.00	0.00	0.01	35.27	-45.28	0.00003	0.03	600	43.59	NS
142.360	-90.13	23.23	0.00	18.74	53.20	0.00	0.00	0.01	35.51	-43.39	0.00005	0.04	600	41.71	NS
153.547	-91.13	23.36	0.00	17.12	56.36	0.00	0.00	0.01	36.17	-39.08	0.00012	0.11	600	37.40	NS
154.524	-92.28	23.36	0.00	17.26	56.38	0.00	0.00	0.01	36.22	-40.30	0.00009	0.08	600	38.62	NS
162.121	-92.27	23.40	0.00	15.46	57.68	0.00	0.00	0.01	36.64	-36.81	0.00021	0.18	600	35.13	NS
172.539	-89.75	22.45	0.00	0.00	57.45	0.00	0.00	0.01	37.18	-17.57	0.01751	15.48	600	15.88	NS
184.724	-90.52	22.73	0.00	0.00	57.06	0.00	0.00	0.01	37.77	-18.42	0.01440	12.73	600	16.73	NS
192.133	-90.97	22.88	0.00	0.00	56.35	0.00	0.00	0.01	38.11	-19.39	0.01152	10.19	600	17.70	NS
194.971	-92.43	22.93	0.00	0.00	58.67	0.00	0.00	0.01	38.24	-18.45	0.01430	12.64	600	16.76	NS
202.810	-91.90	23.06	0.00	0.00	56.63	0.00	0.00	0.01	38.58	-19.74	0.01061	9.38	1000	20.28	NS
208.128	-92.43	23.14	0.00	0.00	56.00	0.00	0.00	0.01	38.81	-20.76	0.00839	7.42	1000	21.30	NS
223.340	-93.65	23.30	0.00	0.00	63.60	0.00	0.00	0.01	39.42	-13.92	0.04051	35.82	1000	14.46	NS
228.259	-94.55	23.33	0.00	0.00	61.15	0.00	0.00	0.01	39.61	-17.11	0.01943	17.18	1000	17.65	NS

Calculation:

FSL (Free Space path Loss) =  $10 * \log ((4 * \pi * D / \lambda)^2)$

EIRP = Reading - Rx Ant. gain + Filter loss - LNA gain + Mixer conversion loss - IF Amp. gain + IF Cable loss + FSL

Power density Result at 3 m =  $EIRP / (4 * \pi * 300^2)$

These calculation results are same as results which were calculated with formulas described in the Section 9 of ANSI C63.10-2013.

- The equipment were not used for factor 0 dB of the data sheets.
- The Mixer conversion loss and IF Cable Loss are automatically corrected in the mixer, so the factor of data sheet were 0 dB.
- The IF Cable loss is included in Mixer loss, so the factor of data sheet were 0 dB.

NS: No signal detected.

#### Plot data, Worst case

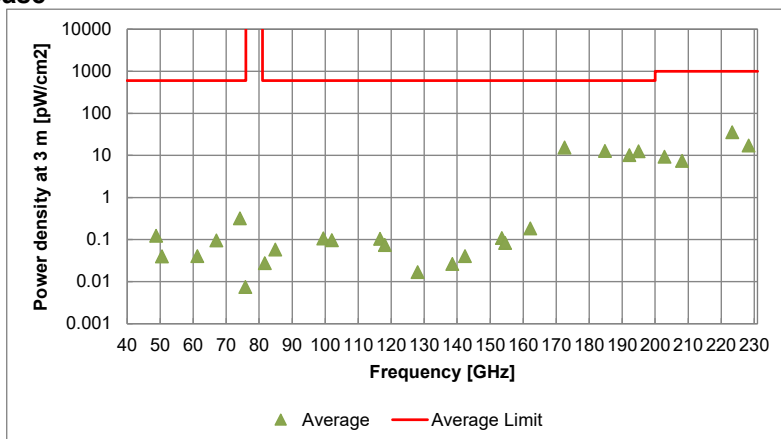

\*These plots data contains sufficient number to show the trend of characteristic features for EUT.

**Field strength of spurious radiation**  
**(Above 40 GHz)**  
(Data only for detected frequency)

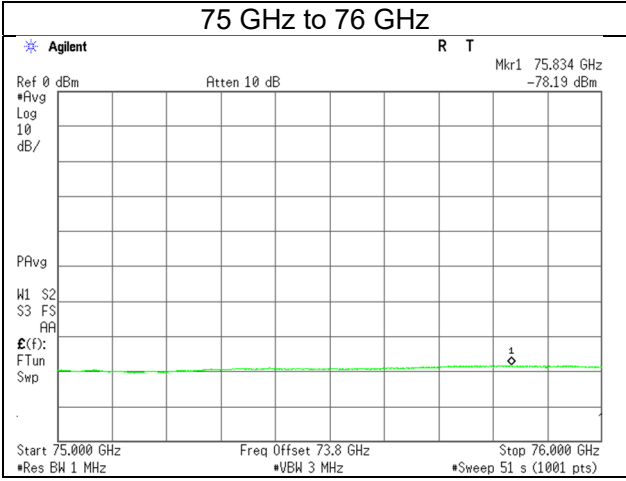

## Frequency Stability

Test place                           Ise EMC Lab.  
Measurement Room                No. 6  
Date                                    April 18, 2024  
Temperature / Humidity            22 deg. C / 42 % RH  
Engineer                             Junki Nagatomi  
Mode                                  Normal operating mode (Mode 1)

Test Condition		20 dB Bandwidth		Remarks
Temperature [deg. C]	Power Supply [V]	The lower frequency [GHz]	The Upper frequency [GHz]	
50	13.2	76.031	76.950	
40	13.2	76.031	76.950	
30	13.2	76.032	76.950	
20	13.2	76.031	76.950	
20	10.2	76.031	76.950	85 % of the rated voltage, DC 12 V * 0.85
20	13.8	76.031	76.950	115 % of the rated voltage, DC 12 V * 1.15
10	13.2	76.032	76.951	
0	13.2	76.032	76.951	
-10	13.2	76.032	76.951	
-20	13.2	76.033	76.952	

Fundamental emissions were contained within the frequency band 76 GHz to 81 GHz during all conditions of operation.

## Frequency Stability

Test place                            Ise EMC Lab.  
Measurement Room                No. 6  
Date                                    April 18, 2024  
Temperature / Humidity            22 deg. C / 42 % RH  
Engineer                             Junki Nagatomi  
Mode                                  Normal operating mode (Mode 2)

Test Condition		20 dB Bandwidth		Remarks
Temperature [deg. C]	Power Supply [V]	The lower frequency [GHz]	The Upper frequency [GHz]	
50	13.2	76.030	76.950	
40	13.2	76.031	76.950	
30	13.2	76.031	76.949	
20	13.2	76.031	76.050	
20	10.2	76.031	76.951	85 % of the rated voltage, DC 12 V* 0.85
20	13.8	76.031	76.950	115 % of the rated voltage, DC 12 V* 1.15
10	13.2	76.032	76.951	
0	13.2	76.032	76.951	
-10	13.2	76.032	76.951	
-20	13.2	76.033	76.952	

Fundamental emissions were contained within the frequency band 76 GHz to 81 GHz during all conditions of operation.

## APPENDIX 2: Test instruments

### Test equipment

Test Item	LIMS ID	Description	Manufacturer	Model	Serial	Last Calibration Date	Cal Int
RE	141217	Coaxial cable	Fujikura/Suhner/TSJ	5D-2W/SFM141/ 421-010/ suoform141-PE/ RFM-E121(SW)	-/04178	06/27/2023	12
RE	141267	Log periodic Antenna (200-1000MHz)	Schwarzbeck Mess-Elektronik OHG	VUSLP9111B	9111B-192	09/21/2023	12
RE	141328	Microwave Cable 1G-40GHz	Suhner	SUCOFLEX102	28636/2	04/01/2024	12
RE	141331	Attenuator(6dB)	TME	UFA-01	-	02/17/2024	12
RE	141397	Coaxial Cable	UL Japan	-	-	11/22/2023	12
RE	141425	Biconical Antenna	Schwarzbeck Mess-Elektronik OHG	VHA9103+ BBA9106	VHA 91031302	08/10/2023	12
RE	141508	Horn Antenna 1-18GHz	Schwarzbeck Mess-Elektronik OHG	BBHA9120D	557	05/17/2023	12
RE	141545	DIGITAL HiTESTER	HIOKI E.E. CORPORATION	3805	51201148	02/01/2024	12
RE	141581	Microwave System Amplifier	Keysight Technologies Inc	83017A	00650	10/05/2023	12
RE	141583	Pre Amplifier	SONOMA INSTRUMENT	310	260833	04/04/2024	12
RE	141885	Spectrum Analyzer	Keysight Technologies Inc	E4448A	US44300523	11/29/2023	12
RE	141951	EMI Test Receiver	Rohde & Schwarz	ESR26	101408	04/10/2023 *1)	12
RE	142011	AC4_Semi Anechoic Chamber (NSA)	TDK	Semi Anechoic Chamber 3m	DA-10005	12/13/2023	24
RE	142017	AC4_Semi Anechoic Chamber (SVSWR)	TDK	Semi Anechoic Chamber 3m	DA-10005	10/11/2023	12
RE	142026	Diplexer	OML INC.	DPL26	-	-	-
RE	142032	Microwave Cable	Huber+Suhner	SUCOFLEX102	37511/2	-	-
RE	142036	Horn Antenna	Custom Microwave Inc.	HO6R	-	09/05/2023	12
RE	142049	Harmonic Mixer	OML INC.	M06HWD	D100709-1	12/04/2023	12
RE	142050	Block Downconverter	Keysight Technologies Inc	PS-X30-W10117A	13715	03/21/2024	12
RE	142152	Loop Antenna	Rohde & Schwarz	HFH2-Z2	836553/009	10/17/2023	12
RE	142230	Measure, Tape, Steel	KOMELON	KMC-36	-	-	-
RE	142529	Detector	HEROTEK, INC.	DT1840P	484823	-	-
RE	159670	Coaxial Cable	UL Japan	-	-	11/21/2023	12
RE	176027	D-Band Low Noise Amplifier	SAGE Millimeter, Inc.	SBL-1141741860- 0606-EI	15235-01	07/11/2023	12
RE	178648	EMI measurement program	TSJ (Techno Science Japan)	TEPTO-DV	-	-	-
RE	180544	Horn Antenna	SAGE Millimeter, Inc.	SAZ-2410-10-S1	17343-01	06/21/2023	12
RE	211944	Digital Storage Oscilloscope	Keysight Technologies Inc	DSOX6002A	MY59380318	12/16/2023	12
RE	234602	Microwave Cable	Huber+Suhner	SF126E/ 11PC35/11PC35/ 1000M,5000M	537063/126E / 537074/126E	03/08/2024	12
RE	244710	Thermo-Hygrometer	HIOKI E.E. CORPORATION	LR5001	231202104	01/25/2024	12
RE	245788	Double Ridge Horn Antenna	Schwarzbeck Mess-Elektronik OHG	BBHA 9120 C	690	03/06/2024	12
RE	141279	Microwave Cable	Junkosha	MMX221- 00500DMSDMS	1502S303	03/04/2024	12
RE	142047	Preselected Millimeter Mixer	Keysight Technologies Inc	11974V-E01	3001A00412	04/04/2024	12
RE	142055	Power Amplifier	SAGE Millimeter, Inc.	SBP-5037532015- 1515-N1	11599-01	03/15/2024	12
RE	180634	Horn Antenna	SAGE Millimeter, Inc.	SAZ-2410-15-S1	17343-01	06/20/2023	12
RE	246778	Microwave Cable	Huber+Suhner	SF126E/11PC35/ 11PC35/2000MM	SN 537000/ 126E	-	-



\*Hyphens for Last Calibration Date and Cal Int (month) are instruments that Calibration is not required (e.g. software), or instruments checked in advance before use.

The expiration date of the calibration is the end of the expired month.  
As for some calibrations performed after the tested dates, those test equipment have been controlled by means of an unbroken chains of calibrations.

The expiration\*1) This test equipment was used for the tests before the expiration date of the calibration.

All equipment is calibrated with valid calibrations. Each measurement data is traceable to the national or international standards.

Test Item: RE: Radiated Emission