



EMI TEST REPORT

Test Report No. : 32IE0311-HO-01-A-R1

Applicant : DENSO CORPORATION
Type of Equipment : Remote Keyless Entry System and TPMS (Receiver)
Model No. : 23AAH
FCC ID : HYQ23AAH
Test standard : FCC Part 15 Subpart B: 2012
Test Result : Complied

1. This test report shall not be reproduced in full or partial, without the written approval of UL Japan, Inc.
2. The results in this report apply only to the sample tested.
3. This sample tested is in compliance with the above regulation.
4. The test results in this report are traceable to the national or international standards.
5. This test report must not be used by the customer to claim product certification, approval, or endorsement by NVLAP, NIST, or any agency of the Federal Government.
6. This report is a revised version of 32IE0311-HO-01-A. 32IE0311-HO-01-A is replaced with this report.

Date of test: May 17 and 18, 2012

Representative test engineer:

Takayuki Shimada
Engineer of WiSE Japan,
UL Verification Service

Approved by:

Shinya Watanabe
Leader of WiSE Japan,
UL Verification Service



NVLAP LAB CODE: 200572-0

This laboratory is accredited by the NVLAP LAB CODE 200572-0, U.S.A. The tests reported herein have been performed in accordance with its terms of accreditation. *As for the range of Accreditation in NVLAP, you may refer to the WEB address, <http://www.ul.com/japan/jpn/pages/services/emc/about/mark1/index.jsp#nvlap>

UL Japan, Inc.

Head Office EMC Lab.

4383-326 Asama-cho, Ise-shi, Mie-ken 516-0021 JAPAN

Telephone : +81 596 24 8116

Facsimile : +81 596 24 8124

CONTENTS	PAGE
SECTION 1: Customer information	3
SECTION 2: Equipment under test (E.U.T.)	3
SECTION 3: Test specification, procedures & results	5
SECTION 4: Operation of E.U.T. during testing	7
SECTION 5: Radiated Emission	8
APPENDIX 1: Data of EMI test	9
Radiated Emission	9
APPENDIX 2: Test instruments	17
APPENDIX 3: Photographs of test setup.....	18
Radiated Emission	18
Worst Case Position (Horizontal: X-axis/ Vertical:X-axis)	19

SECTION 1: Customer information

Company Name : DENSO CORPORATION
Address : 1-1 Showa-cho, Kariya-shi, Aichi-ken, 448-8661 Japan
Telephone Number : +81-566-61-7086
Facsimile Number : +81-566-25-4792
Contact Person : Nobuya Watabe

SECTION 2: Equipment under test (E.U.T.)

2.1 Identification of E.U.T.

Type of Equipment : Remote Keyless Entry System and TPMS (Receiver)
Model No. : 23AAH
Serial No. : Refer to Section 4, Clause 4.2
Receipt Date of Sample : April 26, 2012
Country of Mass-production : Japan
Condition of EUT : Engineering prototype
(Not for Sale: This sample is not mass-produced items.)
Modification of EUT : No Modification by the test lab

UL Japan, Inc.

Head Office EMC Lab.

4383-326 Asama-cho, Ise-shi, Mie-ken 516-0021 JAPAN

Telephone : +81 596 24 8116

Facsimile : +81 596 24 8124

2.2 Product Description

Model No: 23AAH (referred to as the EUT in this report) is the Remote Keyless Entry System and TPMS (Receiver). 23AAH has 6 variations. For details of variations, see "Technical document for Type Approval".

Feature of EUT	:	<RKES mode> RKE system is mainly used for locking or unlocking the doors of the vehicle. The transmitter sends a radio wave signal while the button is pushed. The receiver becomes active in response to the signal from the transmitter. <TPMS mode> Tire Pressure Monitoring System is used for monitoring and indicating information of air pressure in vehicle's tires. Transmitter sends receiver the data that are information of air pressure in vehicle's tire. The data also include temperature, battery voltage and identity code of transmitter. The receiver judges the data. If the data of air pressure and others are not normal condition, the receiver sends signal to a warning lamp. Then, the warning lamp warns drivers.
Frequency of Operation	:	RKES(CH1): 314.35MHz RKES(CH2): 312.10MHz TPMS: 314.98MHz
Oscillator Frequency	:	21.948717MHz (Crystal)
Type of modulation	:	RKES: FSK (F1D) TPMS: FSK (F1D)
Type of receiver	:	Super-heterodyne
Intermediate frequency	:	10.7MHz
Operating voltage (inner)	:	DC 12.0V
Antenna type	:	Internal Antenna (Inverse F Antenna / Inverse L Antenna)

<Note>

RKES: Remote Keyless Entry System

TPMS: Tire Pressure Monitoring System

Hereinafter, "RKES" and "TPMS" are used in this document.

FCC15.111(b)

The receiving antenna (of this EUT) is installed inside the EUT and cannot be removed (permanently attached). Therefore, Radiated emission test was performed.

UL Japan, Inc.

Head Office EMC Lab.

4383-326 Asama-cho, Ise-shi, Mie-ken 516-0021 JAPAN

Telephone : +81 596 24 8116

Facsimile : +81 596 24 8124

SECTION 3: Test specification, procedures & results

3.1 Test specification

Test Specification : FCC Part 15 Subpart B: 2012, final revised on March 30, 2012 and effective April 30, 2012

Title : FCC 47CFR Part15 Radio Frequency Device
Subpart B Unintentional Radiators

3.2 Procedures and results

Item	Test Procedure	Limits	Deviation	Worst margin	Result
Conducted emission	FCC: ANSI C63.4: 2003 7. AC powerline conducted emission measurements	FCC:Part 15 Subpart B 15.107(a)	N/A *1)	N/A	N/A
	IC: RSS-Gen 7.2.4	IC: RSS-Gen 7.2.4			
Radiated emission	FCC: ANSI C63.4: 2003 8. Radiated emission measurements	FCC: Part 15 Subpart B 15.109(a)	N/A	24.8dB 650.100MHz Horizontal, QP Vertical, QP 651.360MHz Horizontal, QP	Complied
	IC: RSS-Gen 4.10	IC: RSS-Gen 6.1			

*Note: UL Japan, Inc's EMI Work Procedure 13-EM-W0420.

*1) The test is not applicable since the EUT is not the device that is designed to be connected to the public utility (AC) power line.

3.3 Addition to standard

No addition, exclusion nor deviation has been made from the standard.

3.4 Uncertainty

EMI

The following uncertainties have been calculated to provide a confidence level of 95% using a coverage factor k=2.

Test room (semi- anechoic chamber)	Radiated emission						
	(3m*)(+dB)				(1m*)(+dB)		(0.5m*)(+dB)
	9kHz -30MHz	30MHz -300MHz	300MHz -1GHz	1GHz -10GHz	10GHz -18GHz	18GHz -26.5GHz	26.5GHz -40GHz
No.1	4.2dB	5.0dB	5.1dB	4.7dB	5.7dB	4.4dB	4.3dB
No.2	4.1dB	5.2dB	5.1dB	4.8dB	5.6dB	4.3dB	4.2dB
No.3	4.5dB	5.0dB	5.2dB	4.8dB	5.6dB	4.5dB	4.2dB
No.4	4.7dB	5.2dB	5.2dB	4.8dB	5.6dB	5.1dB	4.2dB

*3m/1m/0.5m = Measurement distance

Radiated emission test(3m)

The data listed in this test report has enough margin, more than the site margin.

UL Japan, Inc.

Head Office EMC Lab.

4383-326 Asama-cho, Ise-shi, Mie-ken 516-0021 JAPAN

Telephone : +81 596 24 8116

Facsimile : +81 596 24 8124

3.5 Test Location

UL Japan, Inc. Head Office EMC Lab. *NVLAP Lab. code: 200572-0
4383-326 Asama-cho, Ise-shi, Mie-ken 516-0021 JAPAN
Telephone : +81 596 24 8116 Facsimile : +81 596 24 8124

	FCC Registration Number	IC Registration Number	Width x Depth x Height (m)	Size of reference ground plane (m) / horizontal conducting plane	Other rooms
No.1 semi-anechoic chamber	313583	2973C-1	19.2 x 11.2 x 7.7m	7.0 x 6.0m	No.1 Power source room
No.2 semi-anechoic chamber	655103	2973C-2	7.5 x 5.8 x 5.2m	4.0 x 4.0m	-
No.3 semi-anechoic chamber	148738	2973C-3	12.0 x 8.5 x 5.9m	6.8 x 5.75m	No.3 Preparation room
No.3 shielded room	-	-	4.0 x 6.0 x 2.7m	N/A	-
No.4 semi-anechoic chamber	134570	2973C-4	12.0 x 8.5 x 5.9m	6.8 x 5.75m	No.4 Preparation room
No.4 shielded room	-	-	4.0 x 6.0 x 2.7m	N/A	-
No.5 semi-anechoic chamber	-	-	6.0 x 6.0 x 3.9m	6.0 x 6.0m	-
No.6 shielded room	-	-	4.0 x 4.5 x 2.7m	4.75 x 5.4 m	-
No.6 measurement room	-	-	4.75 x 5.4 x 3.0m	4.75 x 4.15 m	-
No.7 shielded room	-	-	4.7 x 7.5 x 2.7m	4.7 x 7.5m	-
No.8 measurement room	-	-	3.1 x 5.0 x 2.7m	N/A	-
No.9 measurement room	-	-	8.0 x 4.5 x 2.8m	2.0 x 2.0m	-
No.10 measurement room	-	-	2.6 x 2.8 x 2.5m	2.4 x 2.4m	-
No.11 measurement room	-	-	3.1 x 3.4 x 3.0m	2.4 x 3.4m	-

* Size of vertical conducting plane (for Conducted Emission test) : 2.0 x 2.0m for No.1, No.2, No.3, and No.4 semi-anechoic chambers and No.3 and No.4 shielded rooms.

3.6 Test set up, Data of EMI, and Test instruments

Refer to APPENDIX.

SECTION 4: Operation of E.U.T. during testing

4.1 Operating modes

The mode used:

1. RKES Receiving mode (314.35MHz, 312.10MHz) *a)

*a) The EUT receives 314.35MHz and 312.10MHz by time sharing.

*a) Electronic Key was operated manually by a test engineer and the test was performed with the EUT receiving 314.35MHz and 312.10MHz and tuning was confirmed to be locked by checking that LED of checker bench was lighted.

2. TPMS Receiving mode (314.98MHz) *b)

*b) Tuning was confirmed to be locked on each mode by checking local oscillator frequency to be stable.

4.2 Configuration and peripherals

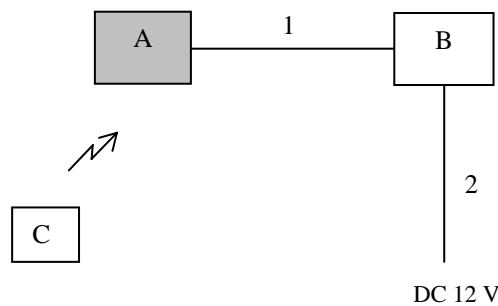

*Cabling and setup were taken into consideration and test data was taken under worse case conditions.

Description of EUT and Support equipment

No.	Item	Model number	Serial number	Manufacturer	Remark
A	Remote Keyless Entry System and TPMS (Receiver)	23AAH	001 (for Variation No.1) 004 (for Variation No.5) Reference data	DENSO CORPORATION	EUT (*Variation No.1 only)
B	Checker Bench	-	-	DENSO CORPORATION	-
C	Electronic Key	-	-	DENSO CORPORATION	-

List of cables used

No.	Name	Length (m)	Shield		Remark
			Cable	Connector	
1	Signal Cable	1.2	Unshielded	Unshielded	-
2	DC Cable	2.0	Unshielded	Unshielded	-

<Note>

* "Variation number" shows the number of the Sample Variations List in the application materials.

UL Japan, Inc.

Head Office EMC Lab.

4383-326 Asama-cho, Ise-shi, Mie-ken 516-0021 JAPAN

Telephone : +81 596 24 8116

Facsimile : +81 596 24 8124

SECTION 5: Radiated Emission

5.1 Operating environment

Test place : No. 3 semi anechoic chamber
Temperature : See data
Humidity : See data

5.2 Test configuration

EUT was placed on a urethane platform of nominal size, 0.5m by 1.0m, raised 0.8m above the conducting ground plane. The EUT was set on the edge of the tabletop. Test was made with the antenna positioned in both the horizontal and vertical planes of polarization. The measurement antenna was varied in height above the conducting ground plane to obtain the maximum signal strength. Photographs of the set up are shown in Appendix 1.

5.3 Test conditions

Frequency range : 30MHz-300MHz (Biconical antenna) / 300MHz-1000MHz (Logperiodic antenna)
1000MHz-2000MHz (Horn antenna)
Test distance : 3m
EUT position : Table top
EUT operation mode : See Clause 4.1

5.4 Test procedure

The height of the measuring antenna varied between 1 and 4m and EUT was rotated a full revolution in order to obtain the maximum value of the electric field intensity. The measurements were performed for both vertical and horizontal antenna polarization with the Test Receiver, or the Spectrum Analyzer. The radiated emission measurements were made with the following detector function of the test receiver and the Spectrum analyzer.

Frequency	Below 1GHz	Above 1GHz
Instrument used	Test Receiver	Spectrum Analyzer
IF Bandwidth	QP: BW 120kHz	PK: RBW:1MHz/VBW: 3MHz AV *1): RBW:1MHz/VBW:10Hz

*1) When using Spectrum analyzer, the test was made with adjusting span to zero by using peak hold.

The noise levels were confirmed at each position of X, Y and Z axes of EUT to see the position of maximum noise, and the test was made at representative X-axis since no difference was found among each position.

5.5 Test result

Summary of the test results: Pass

Date: May 17 and 18, 2012

Test engineer: Takayuki Shimada

UL Japan, Inc.

Head Office EMC Lab.

4383-326 Asama-cho, Ise-shi, Mie-ken 516-0021 JAPAN

Telephone : +81 596 24 8116

Facsimile : +81 596 24 8124

APPENDIX 1: Data of EMI test

Radiated Emission
(RKES: Below 1GHz / Variation No. 1)

DATA OF RADIATED EMISSION TEST

UL Japan, Inc. Head Office EMC Lab. No.3 Semi Anechoic Chamber
Date : 2012/05/17

Report No. : 32IE0311-H0-01
Temp./Humi. : 23deg. C / 51% RH
Engineer : Takayuki Shimada

Mode / Remarks : RKE Receiving mode(314.35MHz, 312.10MHz), Worst-axis(Hor:X, Ver:X)

LIMIT : FCC15.109(a) 3m, below 1GHz:QP, above 1GHz:PK
All other spurious emissions were less than 20dB for the limit.

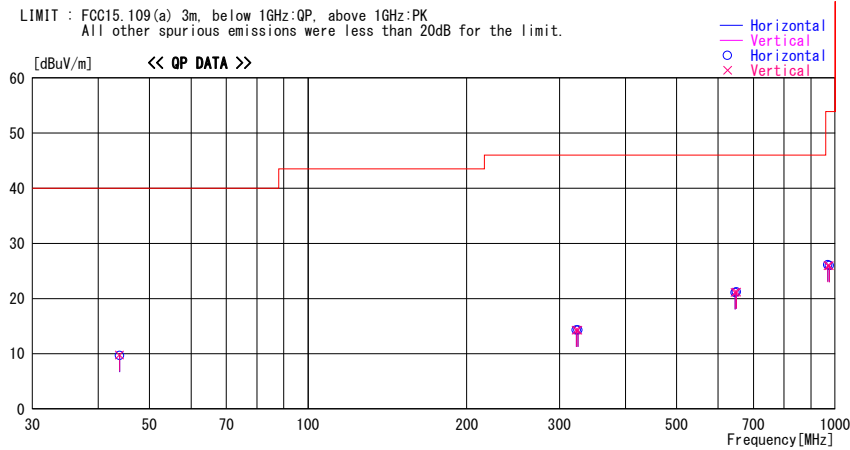

Frequency [MHz]	Reading [dBuV]	DET	Antenna		Level [dBuV/m]	Angle [Deg]	Height [cm]	Polar.	Limit [dBuV/m]	Margin [dB]	Comment
			Factor [dB/m]	Loss& Gain [dB]							
43.897	21.2	QP	13.3	-24.8	9.7	0	300	Hori.	40.0	30.3	
43.897	21.3	QP	13.3	-24.8	9.8	0	100	Vert.	40.0	30.2	
322.800	21.1	QP	15.2	-22.0	14.3	0	100	Vert.	46.0	31.7	
322.800	21.1	QP	15.2	-22.0	14.3	0	100	Hori.	46.0	31.7	
325.050	21.1	QP	15.2	-22.0	14.3	0	100	Vert.	46.0	31.7	
325.050	21.1	QP	15.2	-22.0	14.3	0	100	Hori.	46.0	31.7	
645.600	21.1	QP	19.9	-19.9	21.1	0	100	Vert.	46.0	24.9	
645.600	21.1	QP	19.9	-19.9	21.1	0	100	Hori.	46.0	24.9	
650.100	21.1	QP	20.0	-19.9	21.2	0	100	Vert.	46.0	24.8	
650.100	21.1	QP	20.0	-19.9	21.2	0	100	Hori.	46.0	24.8	
968.400	19.8	QP	23.1	-16.9	26.0	0	100	Vert.	53.9	27.9	
968.400	19.9	QP	23.1	-16.9	26.1	0	100	Hori.	53.9	27.8	
975.150	19.7	QP	23.1	-16.8	26.0	0	100	Vert.	53.9	27.9	
975.150	19.7	QP	23.1	-16.8	26.0	0	100	Hori.	53.9	27.9	

CHART:WITH FACTOR ANT TYPE: -30MHz:LOOP, 30-300MHz:BICONICAL, 300MHz-1000MHz:LOGPERIODIC, 1000MHz-:HORN
CALCULATION:RESULT = READING + ANT FACTOR + LOSS(CABLE+ATTEN.) - GAIN(AMP) + D.FACTOR

*The limit is rounded down to one decimal place.
*The test result is rounded off to one or two decimal places, so some differences might be observed.

Radiated Emission
(RKES: Abohe 1GHz / Variation No. 1)

DATA OF RADIATED EMISSION TEST

UL Japan, Inc. Head Office EMC Lab. No.3 Semi Anechoic Chamber
Date : 2012/05/18

Report No. : 32IE0311-HO-01

Temp./Humi. : 23deg.C / 51% RH
Engineer : Takayuki Shimada

Mode / Remarks : RKE Receiving mode(314.35MHz, 312.10MHz), Worst-axis(Hor:X, Ver:X)

LIMIT : FCC15.109(a) 3m, below 1GHz:QP, above 1GHz:PK
FCC15.109(a) 3m, below 1GHz:QP, above 1GHz:AV

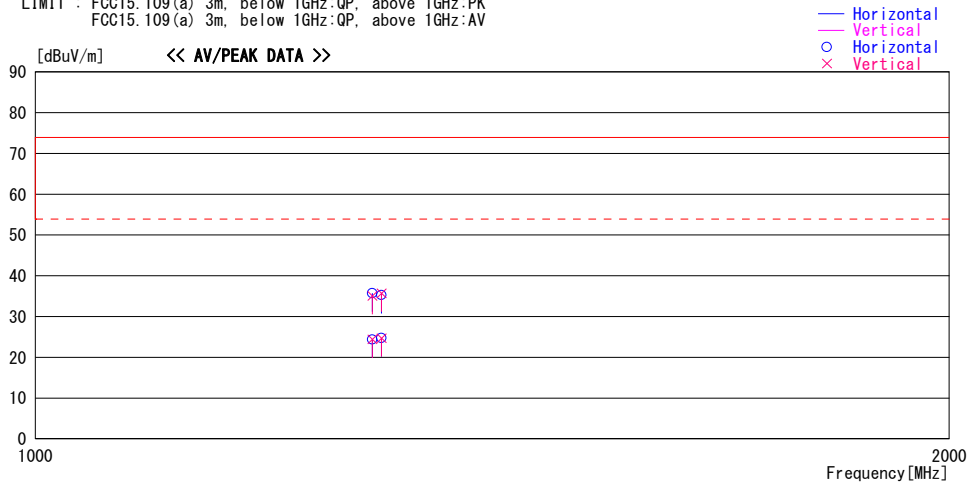

Frequency [MHz]	Reading [dBuV]	DET	Antenna		Level [dBuV/m]	Angle [Deg]	Height [cm]	Polar.	Limit [dBuV/m]	Margin [dB]	Comment
			Factor [dB/m]	Loss& Gain [dB]							
1291.200	43.4	PK	24.8	-32.5	35.7	0	100	Hori.	73.9	38.2	
1291.200	42.8	PK	24.8	-32.5	35.1	0	100	Vert.	73.9	38.8	
1291.200	32.1	AV	24.8	-32.5	24.4	0	100	Hori.	53.9	29.5	
1291.200	32.1	AV	24.8	-32.5	24.4	0	100	Vert.	53.9	29.5	
1300.200	42.9	PK	24.9	-32.5	35.3	0	100	Hori.	73.9	38.6	
1300.200	43.3	PK	24.9	-32.5	35.7	0	100	Vert.	73.9	38.2	
1300.200	32.3	AV	24.9	-32.5	24.7	0	100	Hori.	53.9	29.2	
1300.200	32.3	AV	24.9	-32.5	24.7	0	100	Vert.	53.9	29.2	

CHART:WITH FACTOR ANT TYPE: -30MHz:LOOP, 30-300MHz:BICONICAL, 300MHz-1000MHz:LOGPERIODIC, 1000MHz--:HORN
CALCULATION:RESULT = READING + ANT FACTOR + LOSS(CABLE+ATTEN.) - GAIN(AMP) + D. FACTOR

*The limit is rounded down to one decimal place.

*The test result is rounded off to one or two decimal places, so some differences might be observed.

Radiated Emission
(TPMS: Below 1GHz / Variation No. 1)

DATA OF RADIATED EMISSION TEST

UL Japan, Inc. Head Office EMC Lab. No.3 Semi Anechoic Chamber
Date : 2012/05/18

Report No. : 32IE0311-HO-01
Temp./Humi. : 23deg. C / 51% RH
Engineer : Takayuki Shimada

Mode / Remarks : TPMS Receiving mode(314.98MHz), Worst-axis(Hor:X, Ver:X)

LIMIT : FCC15.109(a) 3m, below 1GHz:QP, above 1GHz:PK
All other spurious emissions were less than 20dB for the limit.

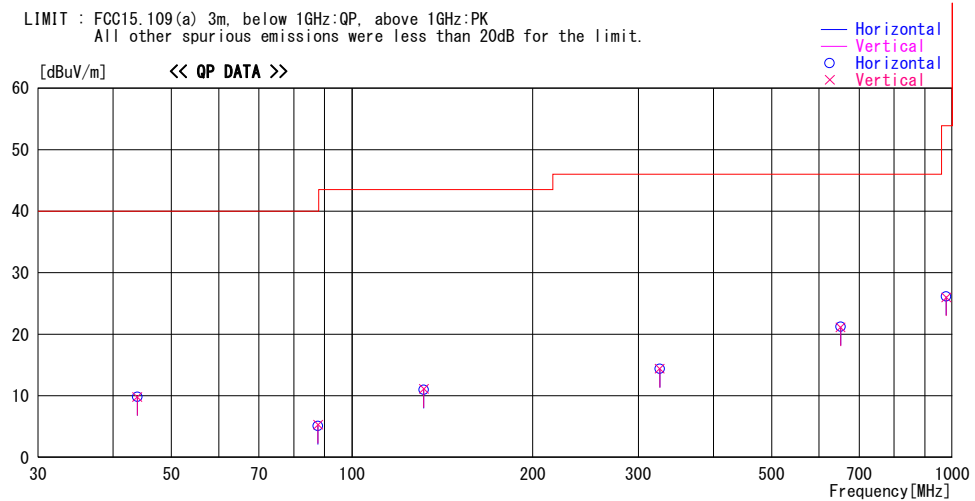

Frequency [MHz]	Reading [dBuV]	DET	Antenna	Loss&	Level [dBuV/m]	Angle [Deg]	Height [cm]	Polar.	Limit [dBuV/m]	Margin [dB]	Comment
			Factor [dB/m]	Gain [dB]							
43.897	21.3	QP	13.3	-24.8	9.8	0	300	Hori.	40.0	30.2	
43.897	21.3	QP	13.3	-24.8	9.8	0	100	Vert.	40.0	30.2	
87.794	21.3	QP	8.0	-24.2	5.1	0	300	Hori.	40.0	34.9	
87.794	21.5	QP	8.0	-24.2	5.3	0	100	Vert.	40.0	34.7	
131.691	21.1	QP	13.8	-23.8	11.1	0	100	Vert.	43.5	32.4	
131.691	21.0	QP	13.8	-23.8	11.0	0	300	Hori.	43.5	32.5	
325.680	21.1	QP	15.3	-22.0	14.4	0	100	Vert.	46.0	31.6	
325.680	21.1	QP	15.3	-22.0	14.4	0	100	Hori.	46.0	31.6	
651.360	21.1	QP	20.0	-19.9	21.2	0	100	Hori.	46.0	24.8	
651.360	21.0	QP	20.0	-19.9	21.1	0	100	Vert.	46.0	24.9	
977.040	19.7	QP	23.2	-16.8	26.1	0	100	Hori.	53.9	27.8	
977.040	19.6	QP	23.2	-16.8	26.0	0	100	Vert.	53.9	27.9	

CHART: WITH FACTOR ANT TYPE: -30MHz: LOOP, 30-300MHz: BICONICAL, 300MHz-1000MHz: LOGPERIODIC, 1000MHz-: HORN
CALCULATION: RESULT = READING + ANT FACTOR + LOSS (CABLE+ATTEN.) - GAIN (AMP) + D. FACTOR

*The limit is rounded down to one decimal place.

*The test result is rounded off to one or two decimal places, so some differences might be observed.

Radiated Emission
(TPMS: Above 1GHz / Variation No. 1)

DATA OF RADIATED EMISSION TEST

UL Japan, Inc. Head Office EMC Lab. No.3 Semi Anechoic Chamber
Date : 2012/05/18

Report No. : 32IE0311-HO-01

Temp./Humi. : 23deg.C / 51% RH
Engineer : Takayuki Shimada

Mode / Remarks : TPMS Receiving mode(314.98MHz), Worst-axis(Hor:X, Ver:X)

LIMIT : FCC15.109(a) 3m, below 1GHz:QP, above 1GHz:PK
FCC15.109(a) 3m, below 1GHz:QP, above 1GHz:AV

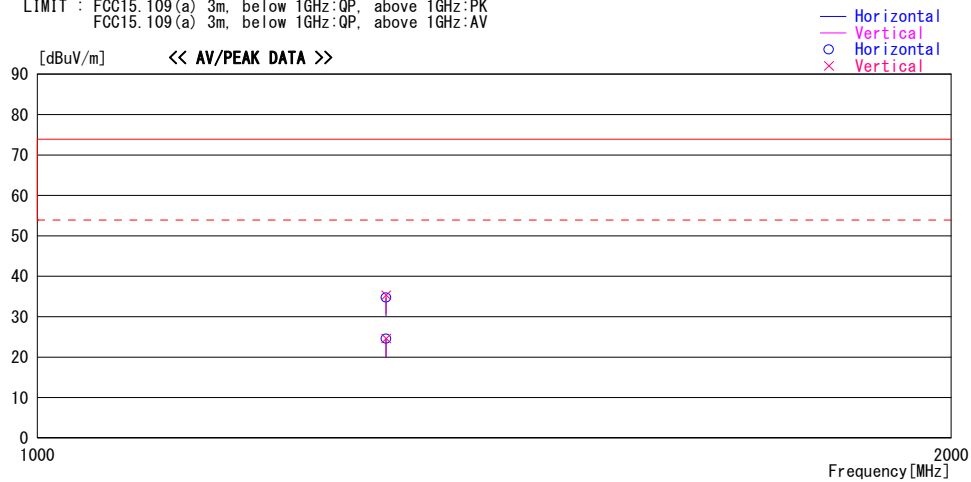

Frequency [MHz]	Reading [dBuV]	DET	Antenna		Level [dBuV/m]	Angle [Deg]	Height [cm]	Polar.	Limit		Comment
			Factor [dB/m]	Loss& Gain [dB]					[dBuV/m]	[dB]	
1302.720	42.9	PK	24.9	-32.5	35.3	0	100	Vert.	73.9	38.6	
1302.720	42.3	PK	24.9	-32.5	34.7	0	100	Hori.	73.9	39.2	
1302.720	32.2	AV	24.9	-32.5	24.6	0	100	Vert.	53.9	29.3	
1302.720	32.2	AV	24.9	-32.5	24.6	0	100	Hori.	53.9	29.3	

CHART:WITH FACTOR ANT TYPE: -30MHz:LOOP, 30-300MHz:BICONICAL, 300MHz-1000MHz:LOGPERIODIC, 1000MHz--:HORN
CALCULATION:RESULT = READING + ANT FACTOR + LOSS(CABLE+ATTEN.) - GAIN(AMP) + D.FACTOR

*The limit is rounded down to one decimal place.
*The test result is rounded off to one or two decimal places, so some differences might be observed.

Radiated Emission
(RKES: Below 1GHz / Variation No. 5: Reference data)

DATA OF RADIATED EMISSION TEST

UL Japan, Inc. Head Office EMC Lab. No. 3 Semi Anechoic Chamber
Date : 2012/05/18

Report No. : 32IE0311-HO-01

Temp./Humi. : 23deg. C / 51% RH
Engineer : Takayuki Shimada

Mode / Remarks : RKES Receiving mode(314.35MHz, 312.10MHz), Worst-axis(Hor:X, Ver:X)

LIMIT : FCC15.109(a) 3m, below 1GHz:QP, above 1GHz:PK
All other spurious emissions were less than 20dB for the limit.

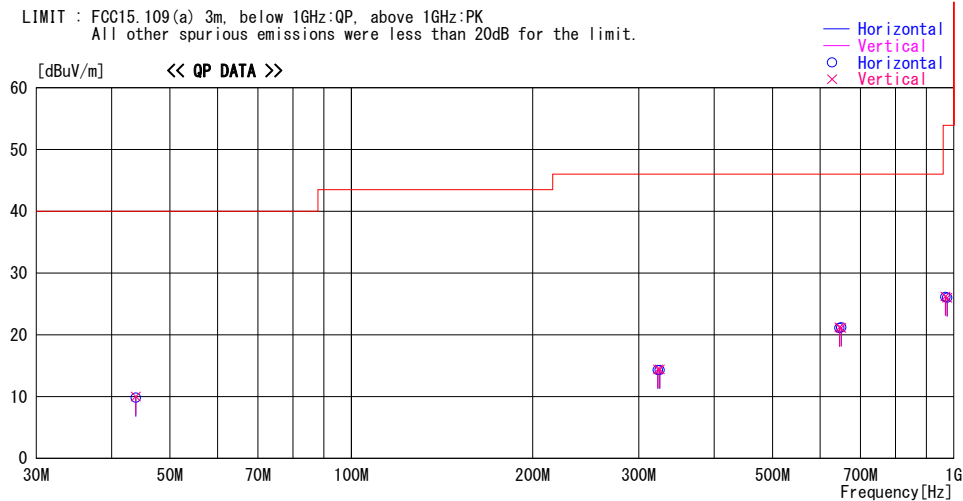

Frequency [MHz]	Reading [dBuV]	DET	Antenna	Loss&	Level [dBuV/m]	Angle [Deg]	Height [cm]	Polar.	Limit	Margin	Comment
			Factor [dB/m]	Gain [dB]					[dBuV/m]	[dB]	
43.897	21.3	QP	13.3	-24.8	9.8	0	300	Hori.	40.0	30.2	
43.897	21.5	QP	13.3	-24.8	10.0	0	100	Vert.	40.0	30.0	
322.800	21.1	QP	15.2	-22.0	14.3	0	100	Hori.	46.0	31.7	
322.800	21.2	QP	15.2	-22.0	14.4	0	100	Vert.	46.0	31.6	
325.050	21.1	QP	15.2	-22.0	14.3	0	100	Hori.	46.0	31.7	
325.050	21.2	QP	15.2	-22.0	14.4	0	100	Vert.	46.0	31.6	
645.600	21.2	QP	19.9	-19.9	21.2	0	100	Vert.	46.0	24.8	
645.600	21.1	QP	19.9	-19.9	21.1	0	100	Hori.	46.0	24.9	
650.100	21.1	QP	20.0	-19.9	21.2	0	100	Hori.	46.0	24.8	
650.100	21.0	QP	20.0	-19.9	21.1	0	100	Vert.	46.0	24.9	
968.400	20.0	QP	23.1	-16.9	26.2	0	100	Vert.	53.9	27.7	
968.400	19.9	QP	23.1	-16.9	26.1	0	100	Hori.	53.9	27.8	
975.150	19.7	QP	23.1	-16.8	26.0	0	100	Hori.	53.9	27.9	
975.150	19.7	QP	23.1	-16.8	26.0	0	100	Vert.	53.9	27.9	

CHART:WITH FACTOR ANT TYPE: -30MHz:LOOP, 30-300MHz:BICONICAL, 300MHz-1000MHz:LOGPERIODIC, 1000MHz--:HORN
CALCULATION:RESULT = READING + ANT FACTOR + LOSS(CABLE+ATTEN.) - GAIN(AMP) + D. FACTOR

*The limit is rounded down to one decimal place.

*The test result is rounded off to one or two decimal places, so some differences might be observed.

Radiated Emission
(RKES: Above 1GHz / Variation No. 5: Reference data)

DATA OF RADIATED EMISSION TEST

UL Japan, Inc. Head Office EMC Lab. No. 3 Semi Anechoic Chamber
Date : 2012/05/18

Report No. : 32IE0311-HO-01
Temp./Humi. : 23deg. C / 51% RH
Engineer : Takayuki Shimada

Mode / Remarks : RKES Receiving mode(314.35MHz, 312.10MHz), Worst-axis(Hor:X, Ver:X)

LIMIT : FCC15.109(a) 3m, below 1GHz:QP, above 1GHz:PK
FCC15.109(a) 3m, below 1GHz:QP, above 1GHz:AV

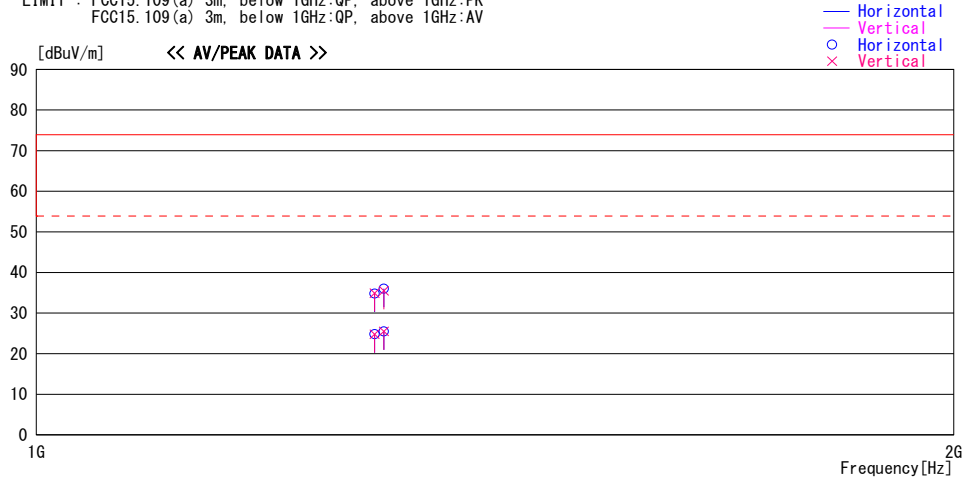

Frequency [MHz]	Reading [dBuV]	DET	Antenna		Level [dBuV/m]	Angle [Deg]	Height [cm]	Polar.	Limit		Margin [dB]	Comment
			Factor [dB/m]	Loss& Gain [dB]					[dBuV/m]	[dB]		
1291.200	42.5	PK	24.8	-32.5	34.8	0	100	Hori.	73.9	39.1		
1291.200	42.6	PK	24.8	-32.5	34.9	0	100	Vert.	73.9	39.0		
1291.200	32.5	AV	24.8	-32.5	24.8	0	100	Hori.	53.9	29.1		
1291.200	32.5	AV	24.8	-32.5	24.8	0	100	Vert.	53.9	29.1		
1300.200	43.6	PK	24.9	-32.5	36.0	0	100	Hori.	73.9	37.9		
1300.200	43.1	PK	24.9	-32.5	35.5	0	100	Vert.	73.9	38.4		
1300.200	33.1	AV	24.9	-32.5	25.5	0	100	Hori.	53.9	28.4		
1300.200	33.1	AV	24.9	-32.5	25.5	0	100	Vert.	53.9	28.4		

CHART: WITH FACTOR ANT TYPE: -30MHz: LOOP, 30-300MHz: BICONICAL, 300MHz-1000MHz: LOGPERIODIC, 1000MHz-: HORN
CALCULATION: RESULT = READING + ANT FACTOR + LOSS (CABLE+ATTEN.) - GAIN (AMP) + D. FACTOR

*The limit is rounded down to one decimal place.
*The test result is rounded off to one or two decimal places, so some differences might be observed.

Radiated Emission
(TPMS: Below 1GHz / Variation No. 5: Reference data)

DATA OF RADIATED EMISSION TEST

UL Japan, Inc. Head Office EMC Lab. No.3 Semi Anechoic Chamber
Date : 2012/05/18

Report No. : 32IE0311-HO-01
Temp./Humi. : 23deg. C / 51% RH
Engineer : Takayuki Shimada

Mode / Remarks : TPMS Receiving mode(314.98MHz), Worst-axis(Hor:X, Ver:X)

LIMIT : FCC15.109(a) 3m, below 1GHz:QP, above 1GHz:PK
All other spurious emissions were less than 20dB for the limit.

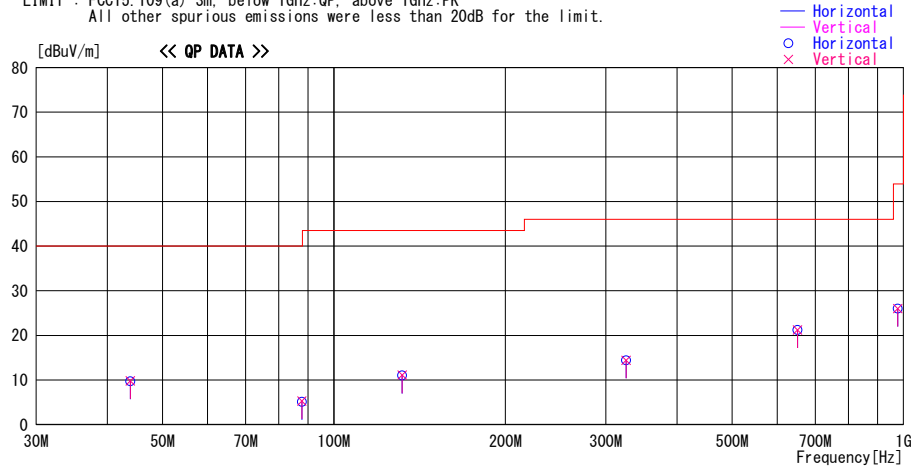

Frequency [MHz]	Reading [dBuV]	DET	Antenna	Loss&	Level	Angle	Height	Polar.	Limit	Margin	Comment
			Factor	Gain							
			[dB/m]	[dB]	[dBuV/m]	[Deg]	[cm]		[dBuV/m]	[dB]	
43.897	21.2	QP	13.3	-24.8	9.7	0	300	Hori.	40.0	30.3	
43.897	21.3	QP	13.3	-24.8	9.8	0	100	Vert.	40.0	30.2	
87.794	21.5	QP	8.0	-24.2	5.3	0	100	Vert.	40.0	34.7	
87.794	21.3	QP	8.0	-24.2	5.1	0	300	Hori.	40.0	34.9	
131.691	21.0	QP	13.8	-23.8	11.0	0	300	Hori.	43.5	32.5	
131.691	21.1	QP	13.8	-23.8	11.1	0	100	Vert.	43.5	32.4	
325.680	21.1	QP	15.3	-22.0	14.4	0	100	Vert.	46.0	31.6	
325.680	21.1	QP	15.3	-22.0	14.4	0	100	Hori.	46.0	31.6	
651.360	21.1	QP	20.0	-19.9	21.2	0	100	Hori.	46.0	24.8	
651.360	21.1	QP	20.0	-19.9	21.2	0	100	Vert.	46.0	24.8	
977.040	19.6	QP	23.2	-16.8	26.0	0	100	Hori.	53.9	27.9	
977.040	19.6	QP	23.2	-16.8	26.0	0	100	Vert.	53.9	27.9	

CHART: WITH FACTOR ANT TYPE: -30MHz: LOOP, 30-300MHz: BICONICAL, 300MHz-1000MHz: LOGPERIODIC, 1000MHz--: HORN
CALCULATION: RESULT = READING + ANT FACTOR + LOSS (CABLE+ATTEN.) - GAIN (AMP) + D. FACTOR

*The limit is rounded down to one decimal place.
*The test result is rounded off to one or two decimal places, so some differences might be observed.

Radiated Emission
(TPMS: Above 1GHz / Variation No. 5: Reference data)

DATA OF RADIATED EMISSION TEST

UL Japan, Inc. Head Office EMC Lab. No. 3 Semi Anechoic Chamber
Date : 2012/05/18

Report No. : 32IE0311-HO-01
Temp./Humi. : 23deg. C / 51% RH
Engineer : Takayuki Shimada

Mode / Remarks : TPMS Receiving mode(314.98MHz), Worst-axis(Hor:X, Ver:X)

LIMIT : FCC15.109(a) 3m, below 1GHz:QP, above 1GHz:PK
FCC15.109(a) 3m, below 1GHz:QP, above 1GHz:AV

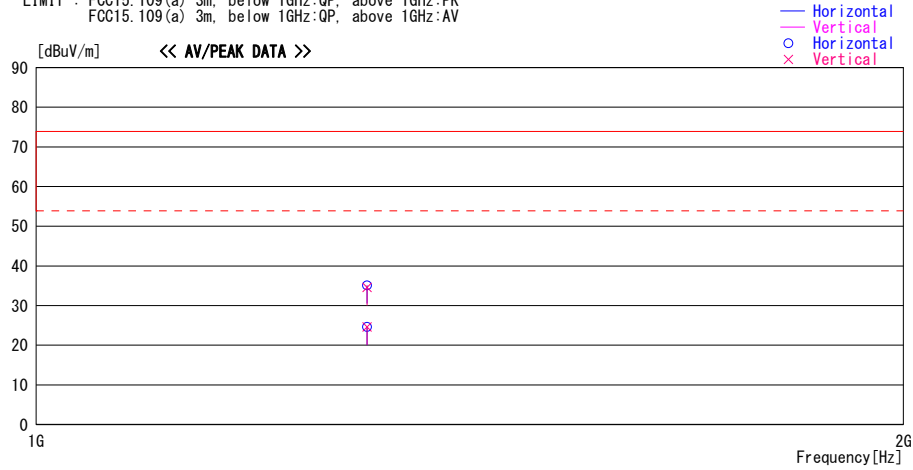

Frequency [MHz]	Reading [dBuV]	DET	Antenna	Loss&	Level [dBuV/m]	Angle [Deg]	Height [cm]	Polar.	Limit	Margin	Comment
			Factor [dB/m]	Gain [dB]					[dBuV/m]	[dB]	
1302.720	42.2	PK	24.9	-32.5	34.6	0	100	Vert.	73.9	39.3	
1302.720	42.7	PK	24.9	-32.5	35.1	0	100	Hori.	73.9	38.8	
1302.720	32.2	AV	24.9	-32.5	24.6	0	100	Vert.	53.9	29.3	
1302.720	32.2	AV	24.9	-32.5	24.6	0	100	Hori.	53.9	29.3	

CHART: WITH FACTOR ANT TYPE: -30MHz: LOOP, 30-300MHz: BICONICAL, 300MHz-1000MHz: LOGPERIODIC, 1000MHz-: HORN
CALCULATION: RESULT = READING + ANT FACTOR + LOSS (CABLE+ATTEN.) - GAIN (AMP) + D. FACTOR

*The limit is rounded down to one decimal place.
*The test result is rounded off to one or two decimal places, so some differences might be observed.

APPENDIX 2: Test instruments

EMI test equipment

Control No.	Instrument	Manufacturer	Model No	Serial No	Test Item	Calibration Date * Interval(month)
MAEC-03	Semi Anechoic Chamber(NSA)	TDK	Semi Anechoic Chamber 3m	DA-10005	RE	2012/02/24 * 12
MOS-15	Thermo-Hygrometer	Custom	CTH-180	-	RE	2012/02/06 * 12
MJM-06	Measure	PROMART	SEN1955	-	RE	-
COTS-MEMI	EMI measurement program	TSJ	TEPTO-DV	-	RE	-
MSA-03	Spectrum Analyzer	Agilent	E4448A	MY44020357	RE	2011/11/23 * 12
APRCV05	Test Receiver	Rohde & Schwarz	ESS	840456/008	RE	2012/01/16 * 12
MBA-03	Biconical Antenna	Schwarzbeck	BBA9106	1915	RE	2011/10/15 * 12
MLA-03	Logperiodic Antenna	Schwarzbeck	USLP9143	174	RE	2011/10/15 * 12
MCC-51	Coaxial cable	UL Japan	-	-	RE	2011/07/15 * 12
MAT-09	Attenuator(6dB)	Weinschel Corp	2	BK7973	RE	2011/11/02 * 12
MPA-13	Pre Amplifier	SONOMA INSTRUMENT	310	260834	RE	2012/03/16 * 12
MHA-20	Horn Antenna 1-18GHz	Schwarzbeck	BBHA9120D	258	RE	2011/05/23 * 12
MCC-133	Microwave Cable	HUBER+SUHNER	SUCOFLEX104	336164/4(1m) / 340640(5m)	RE	2011/09/07 * 12
MPA-11	MicroWave System Amplifier	Agilent	83017A	MY39500779	RE	2012/03/29 * 12
MSA-05	Spectrum Analyzer	Advantest	R3273	160400285	RE	2011/11/23 * 12

The expiration date of the calibration is the end of the expired month.

All equipment is calibrated with valid calibrations. Each measurement data is traceable to the national or international standards.

As for some calibrations performed after the tested dates, those test equipment have been controlled by means of an unbroken chains of calibrations.

Test Item:

RE: Radiated emission

UL Japan, Inc.

Head Office EMC Lab.

4383-326 Asama-cho, Ise-shi, Mie-ken 516-0021 JAPAN

Telephone : +81 596 24 8116

Facsimile : +81 596 24 8124