

TEST RESULT SUMMARY

FCC PART 15 SUBPART C

Section 15.231

MANUFACTURER'S NAME	Denso Corp
NAME OF EQUIPMENT	Transmitter for Keyless Entry System
MODEL NUMBER	12BBD
MANUFACTURER'S ADDRESS	1-1 Showa-cho, Kariya-shi Aichi-ken, 448-8661 Japan
TEST REPORT NUMBER	W9555
TEST DATE	05 November 1999

According to testing performed at TÜV Product Service Inc, the above-mentioned unit is in compliance with the electromagnetic compatibility requirements defined in FCC Part 15.

It is the manufacturer's responsibility to assure that additional production units of this model are manufactured with identical electrical and mechanical characteristics. Any modifications necessary for compliance made during testing on the above mentioned date(s) must be implemented in all production units for compliance to be maintained.

TÜV Product Service Inc, as an independent testing laboratory, declares that the equipment tested as specified above conforms to the requirements of FCC Part 15.

Date: 10 November 1999



G. S. Jakubowski
Test Engineer

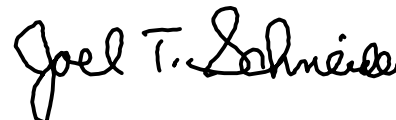

J. T. Schneider
Lead Engineer

Location: Taylors Falls MN
USA

Not Transferable

EMC EMISSION - TEST REPORT

Test Report File No. : **WC1H955501** Date of issue: 10 November 1999

Model / Serial No. : **12BBD /**

Product Type : Transmitter for Remote Keyless Entry System

Applicant : Denso Corp

Manufacturer : Denso Corp

License holder : Denso Corp

Address : 1-1 Showa-cho, Kariya-shi

: Aichi-ken, 448-8661 Japan

Test Result : **Positive** **Negative**

Test Project Number Reference(s) : **W9555**

Total pages including Appendices : **24**

TÜV Product Service Inc is a subcontractor to TÜV Product Service, GmbH according to the principles outlined in ISO/IEC Guide 25 and EN 45001.

TÜV Product Service Inc reports apply only to the specific samples tested under stated test conditions. It is the manufacturer's responsibility to assure that additional production units of this model are manufactured with identical electrical and mechanical components. TÜV Product Service Inc shall have no liability for any deductions, inferences or generalizations drawn by the client or others from TÜV Product Service Inc issued reports.

This report is the confidential property of the client. As a mutual protection to our clients, the public and ourselves, extracts from the test report shall not be reproduced except in full without our written approval. This report shall not be used by the client to claim product endorsement by NVLAP or any agency of the US government.

TÜV Product Service Inc and its professional staff hold government and professional organization certifications and are members of AAMI, ACIL, AEA, ANSI, IEEE, NVLAP, and VCCI

D I R E C T O R Y - E M I S S I O N S

		Page(s)
A)	Documentation	
	Test report	<u>1 - 10</u>
	Directory	<u>2</u>
	Test Regulations	<u>3</u>
	Deviation from standard / Summary	<u>10</u>
	Test-setups (Photos)	<u>11 - 12</u>
	Test-setup (drawing)	<u>Appendix A</u>
B)	Test data	
	Conducted emissions 10/150 kHz - 30 MHz	<u>5, 9</u>
	Radiated emissions 10 kHz - 30 MHz	<u>5, 9</u>
	Radiated emissions 30 MHz - 1000 MHz	<u>6, 9</u>
	Interference power 30 MHz - 300 MHz	<u>6, 9</u>
	Equivalent Radiated emissions 1 GHz - 18 GHz	<u>7, 9</u>
C)	Appendix A	
	Test Data Sheets and Test Setup Drawing(s)	<u>A2 - A7</u>
D)	Appendix B	
	Constructional Data Form	<u>B2</u>
	Product Information Form(s)	<u>B3</u>
E)	Appendix C	
	Measurement Protocol	<u>C1 - C2</u>

EMISSIONS TEST REGULATIONS :

The emissions tests were performed according to following regulations:

- | | | |
|--|---|------------------------------------|
| <input type="checkbox"/> - EN 50081-1 / 1991 | <input type="checkbox"/> - Group 1 | <input type="checkbox"/> - Group 2 |
| <input type="checkbox"/> - EN 55011 / 1991 | <input type="checkbox"/> - Class A | <input type="checkbox"/> - Class B |
| <input type="checkbox"/> - EN 55013 / 1990 | <input type="checkbox"/> - Household appliances and similar | |
| <input type="checkbox"/> - EN 55014 / 1987 | <input type="checkbox"/> - Portable tools | |
| | <input type="checkbox"/> - Semiconductor devices | |
| <input type="checkbox"/> - EN 55014 / A2:1990 | <input type="checkbox"/> - Household appliances and similar | |
| <input type="checkbox"/> - EN 55014 / 1993 | <input type="checkbox"/> - Portable tools | |
| | <input type="checkbox"/> - Semiconductor devices | |
| <input type="checkbox"/> - EN 55015 / 1987 | | |
| <input type="checkbox"/> - EN 55015 / A1:1990 | | |
| <input type="checkbox"/> - EN 55015 / 1993 | | |
| <input type="checkbox"/> - EN 55022 / 1987 | <input type="checkbox"/> - Class A | <input type="checkbox"/> - Class B |
| <input type="checkbox"/> - EN 55022 / 1994 | <input type="checkbox"/> - Class A | <input type="checkbox"/> - Class B |
| <input type="checkbox"/> - BS | | |
| <input type="checkbox"/> - VCCI | <input type="checkbox"/> - Class A | <input type="checkbox"/> - Class B |
| <input checked="" type="checkbox"/> - FCC Part 15 Subpart C Section 15.231 | | |
| <input type="checkbox"/> - AS 3548 (1992) | <input type="checkbox"/> - Class A | <input type="checkbox"/> - Class B |
| <input type="checkbox"/> - CISPR 11 (1990) | <input type="checkbox"/> - Group 1 | <input type="checkbox"/> - Group 2 |
| | <input type="checkbox"/> - Class A | <input type="checkbox"/> - Class B |
| <input type="checkbox"/> - CISPR 22 (1993) | <input type="checkbox"/> - Class A | <input type="checkbox"/> - Class B |

Environmental conditions in the lab:

	<u>Actual</u>
Temperature	: 22 °C
Relative Humidity	: 35 %
Atmospheric pressure	: 98.8 kPa
Power supply system	: 3 VDC

Sign Explanations:

- not applicable
- applicable



Emissions Test Conditions: CONDUCTED EMISSIONS (Interference Voltage)

The *CONDUCTED EMISSIONS (INTERFERENCE VOLTAGE)* measurements were performed at the following test location:

- Test not applicable

- Wild River Lab Large Test Site (Open Area Test Site)
- Wild River Lab Small Test Site (Open Area Test Site)
- Oakwood Lab (Open Area Test Site)
- Wild River Lab Screen Room
- New Brighton Lab Shielded Room

Test equipment used :

Model Number	Manufacturer	Description	Serial Number	Cal Date
--------------	--------------	-------------	---------------	----------

Use of the calibrated equipment on this list ensures traceability to national and international standards.

Emissions Test Conditions: RADIATED EMISSIONS (Magnetic Field)

The *RADIATED EMISSIONS (MAGNETIC FIELD)* measurements were performed at the following test location:

- Wild River Lab Large Test Site (Open Area Test Site)
- Wild River Lab Small Test Site (Open Area Test Site)
- Oakwood Lab (Open Area Test Site)

at a test distance of :

- 3 meters
- 30 meters

- Test not applicable

Test equipment used :

Model Number	Manufacturer	Description	Serial Number	Cal Date
--------------	--------------	-------------	---------------	----------

Emissions Test Conditions: RADIATED EMISSIONS (Electric Field)

The *RADIATED EMISSIONS (ELECTRIC FIELD)* measurements, in the frequency range of 30 MHz-1000 MHz, were tested in a horizontal and vertical polarization at the following test location :

- Test not applicable

- Wild River Lab Large Test Site (Open Area Test Site)
- Wild River Lab Small Test Site (Open Area Test Site)
- Oakwood Lab (Open Area Test Site)

at a test distance of :

- 3 meters
- 10 meters
- 30 meters

Test equipment used :

Model Number	Manufacturer	Description	Serial Number	Cal Date
■ - EM-6917B	Electro-Metrics	Biconicalog Antenna	101	9-99
■ - 8566B	Hewlett-Packard	Spectrum Analyzer	2221A01596	4-99
■ - 85662A	Hewlett-Packard	Analyzer Display	2152A03640	4-99
■ - 85650A	Hewlett-Packard	Quasi-Peak Adapter	2811A01127	4-99
■ - ZHL-1042J	Mini-Circuits	Preamplifier	H072294-11	3-99

Use of the calibrated equipment on this list ensures traceability to national and international standards.

Emissions Test Conditions: INTERFERENCE POWER

The *INTERFERENCE POWER* measurements were performed by using the absorbing clamp on the mains and interface cables in the frequency range 30 MHz - 300 MHz at the following test location :

- Test not applicable

- Wild River Lab Large Test Site (Open Area Test Site)
- Wild River Lab Small Test Site (Open Area Test Site)
- Oakwood Lab (Open Area Test Site)
- Wild River Lab Screen Room
- New Brighton Lab Shielded Room

Test equipment used :

Model Number	Manufacturer	Description	Serial Number	Cal Date
--------------	--------------	-------------	---------------	----------

Emissions Test Conditions: RADIATED EMISSIONS (Electric Field)

The *EQUIVALENT RADIATED EMISSIONS* measurements in the frequency range 1 GHz - 3.2 GHz were performed in a horizontal and vertical polarization at the following test location :

- Wild River Lab Large Test Site (Open Area Test Site)
- Wild River Lab Small Test Site (Open Area Test Site)
- Oakwood Lab (Open Area Test Site)
- Wild River Lab Screen Room

at a test distance of:

- 1 meters
- 3 meters
- 10 meters

- Test not applicable

Test equipment used :

Model Number	Manufacturer	Description	Serial Number	Cal Date
■ - EM-6917B	Electro-Metrics	Biconicalog Antenna	101	9-99
■ - 8566B	Hewlett-Packard	Spectrum Analyzer	2221A01596	4-99
■ - 85662A	Hewlett-Packard	Analyzer Display	2152A03640	4-99
■ - 85650A	Hewlett-Packard	Quasi-Peak Adapter	2811A01127	4-99
■ - ZHL-1042J	Mini-Circuits	Preamplifier	H072294-11	3-99

Use of the calibrated equipment on this list ensures traceability to national and international standards.

Equipment Under Test (EUT) Test Operation Mode - Emission tests :

The device under test was operated under the following conditions during emissions testing:

- Standby
- Test program (H - Pattern)
- Test program (color bar)
- Test program (customer specific)
- Practice operation
- Normal Operating Mode
- Transmitter on.

Configuration of the device under test:

- See Constructional Data Form in Appendix B - Page B2
- See Product Information Form in Appendix B - beginning on Page B3

The following peripheral devices and interface cables were connected during the measurement:

- | | |
|----------------------------------|--------------|
| <input type="checkbox"/> - _____ | Type : _____ |
| <input type="checkbox"/> - _____ | Type : _____ |
| <input type="checkbox"/> - _____ | Type : _____ |
| <input type="checkbox"/> - _____ | Type : _____ |
| <input type="checkbox"/> - _____ | Type : _____ |
| <input type="checkbox"/> - _____ | Type : _____ |
| <input type="checkbox"/> - _____ | Type : _____ |
| <input type="checkbox"/> - _____ | Type : _____ |

- unshielded power cable
- unshielded cables
- shielded cables
- customer specific cables

MPS.No.: _____

- _____
- _____

Emission Test Results:

Conducted emissions 10/150 kHz - 30 MHz

The requirements are - MET - NOT MET

Minimum limit margin _____ dB at _____ MHz

Maximum limit exceeding _____ dB at _____ MHz

Remarks: _____

Radiated emissions (magnetic field) 10 kHz - 30 MHz

The requirements are - MET - NOT MET

Minimum limit margin _____ dB at _____ MHz

Maximum limit exceeding _____ dB at _____ MHz

Remarks: _____

Radiated emissions (electric field) 30 MHz - 1000 MHz

The requirements are - MET - NOT MET

Minimum limit margin for fundamental _____ 2 dB at _____ 314.3 MHz

Minimum limit margin for spurious _____ 17 dB at _____ 628.7 MHz

Remarks: The fundamental was measured to be 79.5 dBuV/m in peak mode, minus 6 dB (based on 46.7% duty cycle) to get average measurement, or 73.5 dBuV/m (4731 uV/m) compared to a limit of 75.5 dBuV/m (6014 uV/m). The second harmonic was measured to be 43.6 dBuV/m in peak mode, minus 6 dB (based on 46.7% duty cycle) to get average measurement, or 37.6 dBuV/m (75.8 uV/m) compared to an average limit of 55.5 dBuV/m (595.6 uV/m).

Interference Power at the mains and interface cables 30 MHz - 300 MHz

The requirements are - MET - NOT MET

Minimum limit margin _____ dB at _____ MHz

Maximum limit exceeding _____ dB at _____ MHz

Remarks: _____

Equivalent Radiated emissions 1 GHz - 3.14 GHz

The requirements are - MET - NOT MET

Minimum limit margin _____ 7 dB at _____ 2515.0 MHz

Maximum limit exceeding _____ dB at _____ MHz

Remarks: Peak analyzer reading of 54.1 dBuV/m, minus 6 dB (based on 46.7% duty cycle) to get average measurement, or 48.1 dBuV/m (254 uV/m), compared to an average limit of 55.5 dBuV/m (595.6 uV/m).

DEVIATIONS FROM STANDARD:

None.

GENERAL REMARKS:

The bandwidth of the fundamental must be less than 0.25% of the center frequency, or 785 kHz. Page A5 of A7 shows the bandwidth to be less than 70 kHz. The transmitter is on for 46.7 msec/100 msec, so a duty cycle relaxation factor of $20 \log 46.7/100$, or 6 dB is used to convert peak readings to average readings. Pages A6 and A7 of A7 show the on/off times - over a 100 msec span, there were 11 pulses of 1.5 msec width and 42 pulses of 0.72 msec width.

SUMMARY:

The requirements according to the technical regulations are

- met
- **not** met.

The device under test does

- fulfill the general approval requirements mentioned on page 3.
- **not** fulfill the general approval requirements mentioned on page 3.

Testing Start Date: 05 November 1999

Testing End Date: 05 November 1999

- TÜV PRODUCT SERVICE INC -

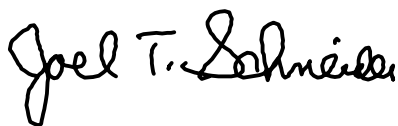

J. T. Schneider
Lead Engineer



Tested By:
G. S. Jakubowski

Test-setup photo(s):
Conducted emission 10/150 kHz - 30 MHz

Not Applicable

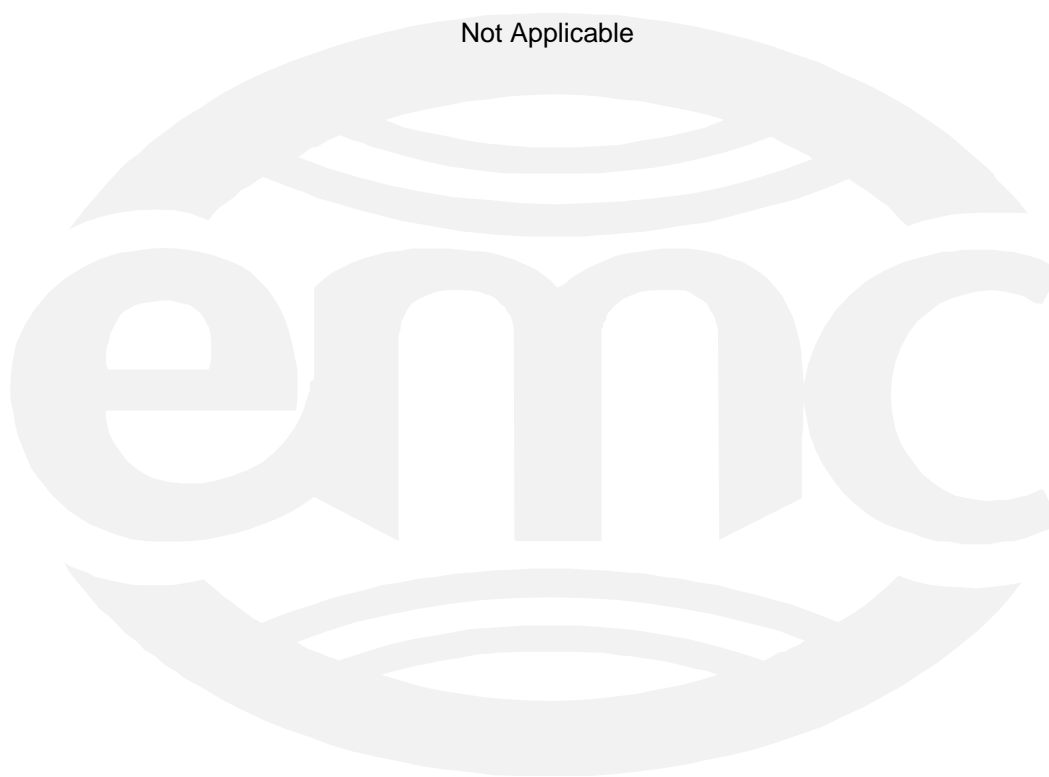

Test-setup photo(s):
Radiated emission 30 MHz - 3.14 GHz



Appendix A

Test Data Sheets
and
Test Setup Drawing(s)



TEST SETUP FOR EMISSIONS TESTING

WILD RIVER LAB Large Test Site

Notes:

1. Items shown in dotted lines are located on the floor below the test area. It is 5 meters vertically from the ground floor to the test area.
2. 50 Hz, 60 Hz, and 400 Hz are power panels for alternating current.
3. The antenna may be positioned horizontally 3, 10 or 30 meters from the center of the turntable.
4. The circle is a 6.7 meter diameter turntable.
5. A ground plane is in the plane of this sheet.
6. The test sample is shown in the azimuthal position representing zero degrees.

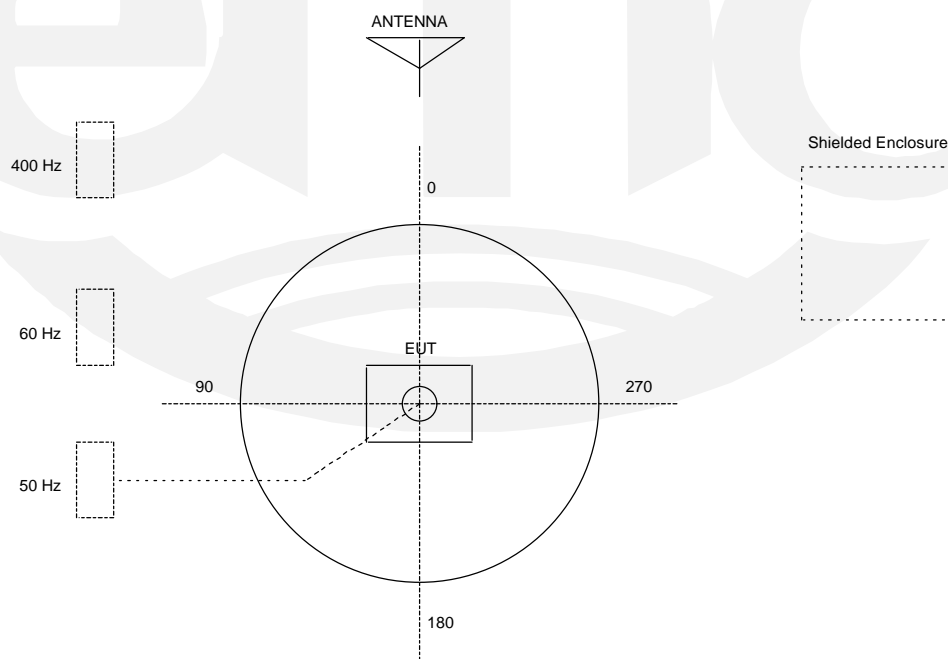

T U V P R O D U C T S E R V I C E

RADIATED EMISSIONS

Large Test Site
 3 Meter Antenna Distance
 Equipment Under Test:
 DENSO
 12BBD TRANSMITTER

Report W9555 Run 1
 Date 11-05-99 Page 1
 Engineer _____
 Tech: GSJ _____
 Requester _____

Notes:

Frequency MHz	Level dBuV	Factor dB	Cable dB	Peak dBuV/m	Ave dBuV/m	Polar\ Height	15.231 dBuV/m	Limit
EUT STANDING UPRIGHT								
0 DEGREES = FRONT								
FUNDAMENTAL MAXED AT 90 DEGREES, VERTICAL ANTENNA, 1.74 METER HIGH (6 DB PEAK-AVERAGE DUTY CYCLE CORRECTION)								
314.37	60.2	13.7	1.6	75.6	69.6	V --	75.5	
EUT ON RIGHT SIDE								
MAXED AT 0 DEG, HORIZ, 1.3 M								
314.37	59.68	13.7	1.6	75.1	69.1	H --	75.5	
EUT ON ITS BACK, 0 DEGREES = BOTTOM								
MAXED AT 118 DEG, HORIZ, 1 M								
314.37	64.08	13.7	1.6	79.5	73.5	H --	75.5	
WORST CASE AXIS								
2ND HARMONIC MAXED AT 310 DEG, HORIZ, 1.2 M								
628.76	21.6	19.6	2.4	43.6	37.6	H --	55.5	
3RD MAXED AT 130 DEG, HORIZ, 1 M								
943.14	18.34	22	3	43.4	37.4	H --	55.5	
4TH MAXED AT 135 DEG, HORIZ, 1.22 M								
1257.5	18.06	24.5	3.6	46.1	40.1	H --	55.5	
5TH MAXED AT 240 DEG, HORIZ, 1.45 M								
1571.9	7.4	27.6	4.1	39	33	H --	54	
6TH MAXED AT 270 DEG, HORIZ, 1.5 M								
1886.2	16.04	28.2	4.5	48.7	42.7	H --	55.5	
7TH MAXED AT 57 DEG, HORIZ, 1 M								
2200.6	11.42	29.7	4.9	46	40	H --	54	
8TH MAXED AT 55 DEG, HORIZ, 1 M								
2515.0	17.48	31.3	5.3	54.1	48.1	H --	55.5	
9TH MAXED AT 93 DEG, VERT, 1 M								
2829.4	8.38	31.2	5.7	45.3	39.3	V --	54	
3143.8	.22	32.9	6	39.2	33.2	V --	55.5	

T U V P R O D U C T S E R V I C E

RADIATED EMISSIONS

Large Test Site
 3 Meter Antenna Distance
 Equipment Under Test:
 DENSO
 12BBD TRANSMITTER
 Notes:

Figure_____

Report W9555 Run 1
 Date 11-05-99 Page 2
 Engineer _____
 Tech: GSJ _____
 Requester _____

Measurement Summary

Frequency MHz	----- Final dBuV/m	----- uV/m	Azimuth deg	Polar\ Height	Delta 15.231	Delta
314.37	73.5	4731.5	--	H --	-2	
628.76	37.6	75.857	--	H --	-17.9	
943.14	37.4	74.131	--	H --	-18.1	
1257.5	40.1	101.15	--	H --	-15.4	
1571.9	33	44.668	--	H --	-21	
1886.2	42.7	136.45	--	H --	-12.8	
2200.6	40	100.00	--	H --	-14	
2515.0	48.1	254.09	--	H --	-7.4	
2829.4	39.3	92.257	--	V --	-14.7	
3143.8	33.2	45.708	--	V --	-22.3	

File W9555 Run 1

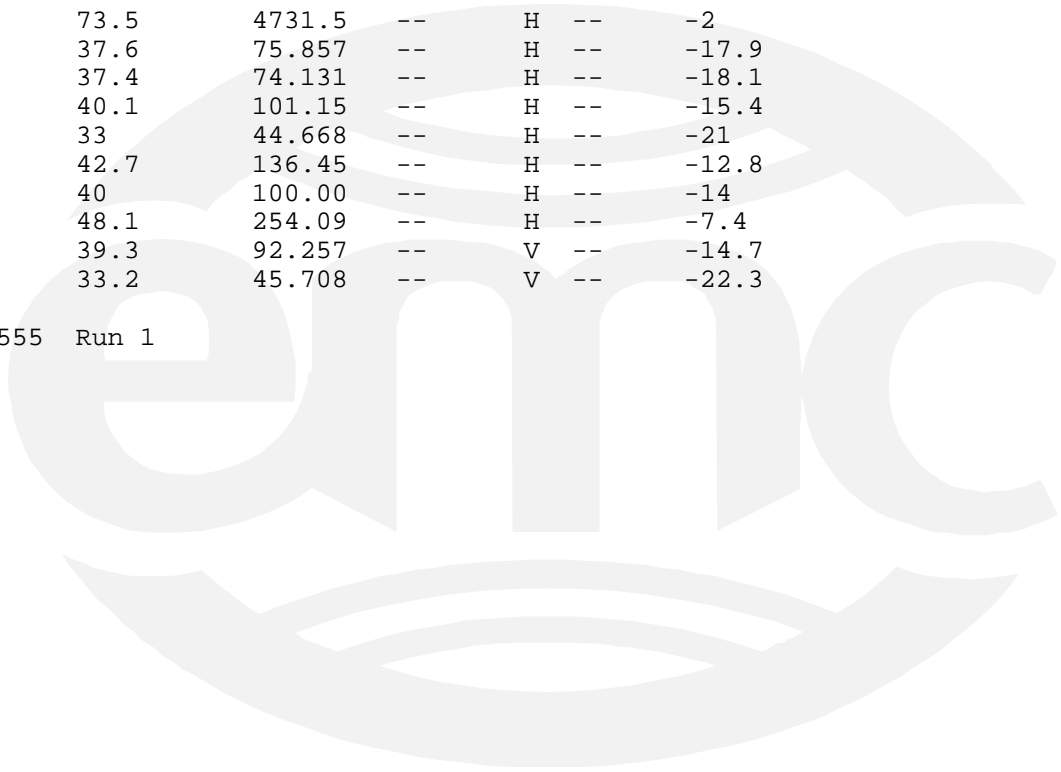

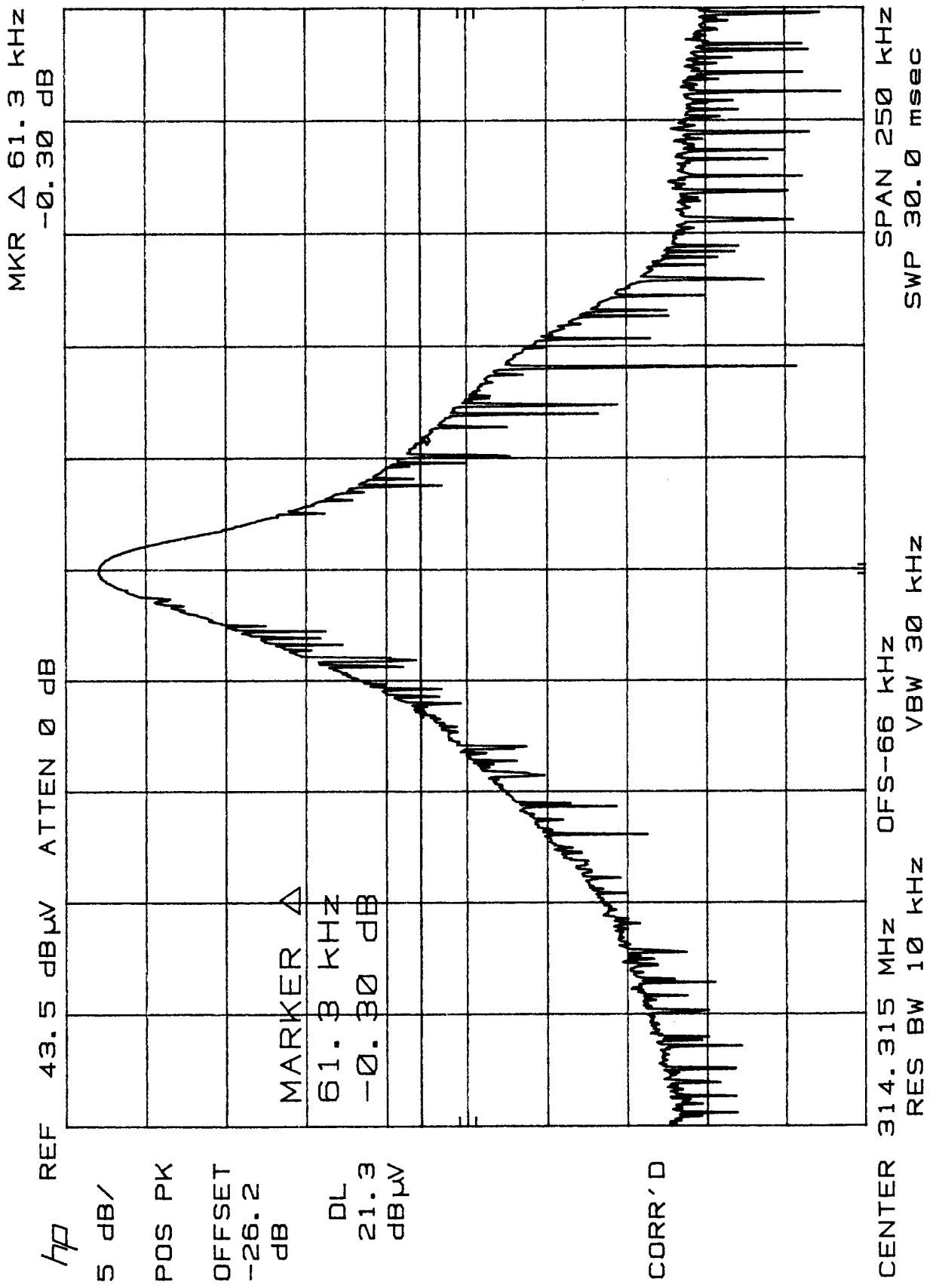

hp REF 62.8 dBμV ATTEN 0 dB

10 dB/

POS PK

OFFSET

-26.2

dB

SWEEP TIME

100 msec

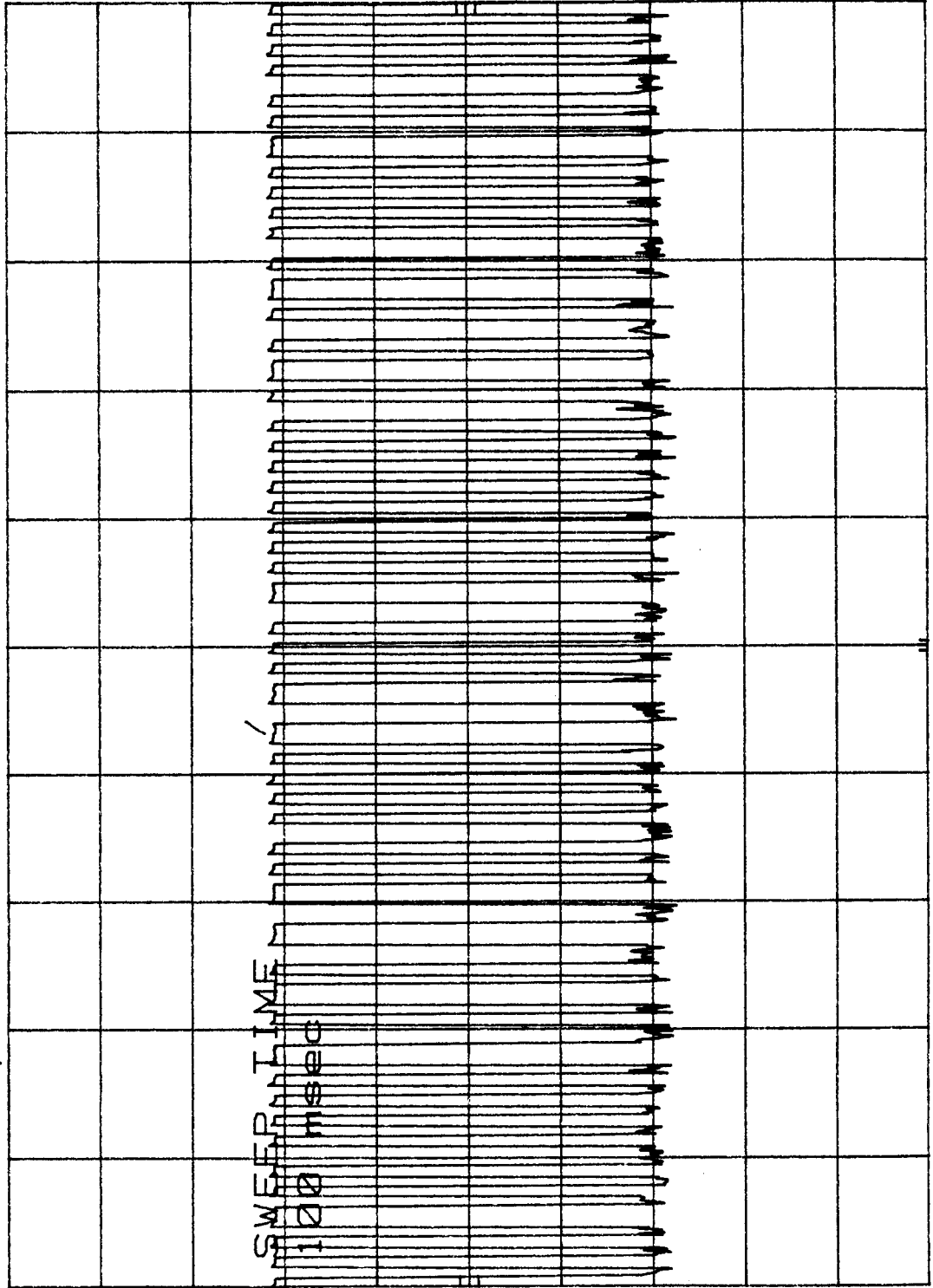

CORR'D

CENTER 314.448 588 MHz DFS--66.000 kHz

RES BW 3 MHz

VBW 30 kHz

SPAN 0 Hz

SWP 100 msec

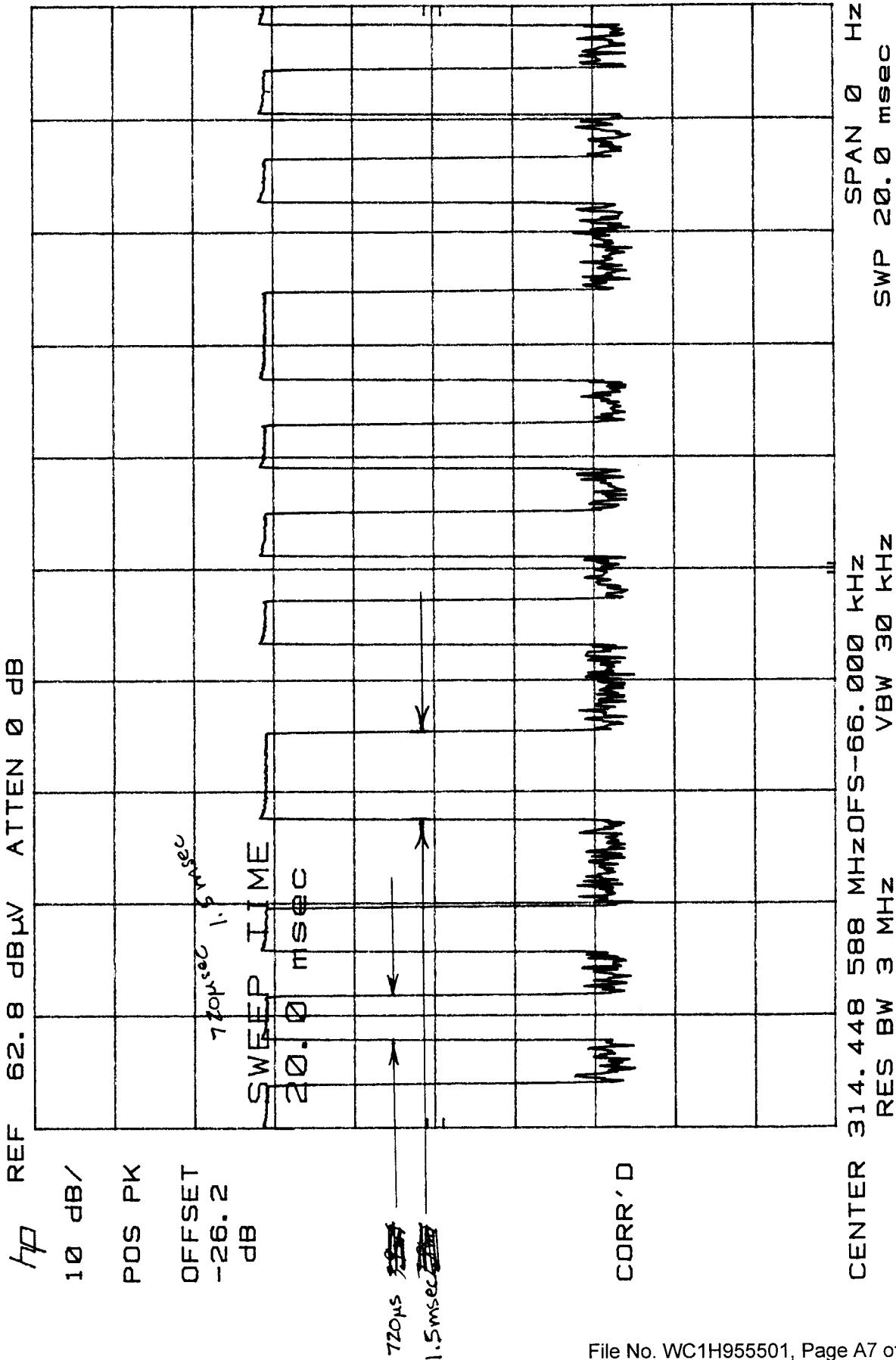

Appendix B

Constructional Data Form
and
Product Information Form(s)



Constructional Data Form

Not Applicable



Technical Description of the systemType number

- Transmitter :12BBD

Specifications of receiver

- Nominal frequency :314.35 MHz
- Local oscillator frequency :314.35 MHz SAW resonator circuit

- Radio frequency output power :75.6 dBuV/m or less
- Type of modulation :A1D
- Power supply
 - Nominal supply voltage :3 VDC
 - Type of battery :One lithium battery
- Antenna :Built-in type (fixed)

Description of the system operation

This system is mainly used for locking or unlocking the doors of the vehicle. The transmitter sends a radio wave signal while the button is pushed. The receiver becomes active in response to the signal from the transmitter.

Installation in vehicle

The receiver is installed inside the vehicle.

Appendix C

MEASUREMENT PROTOCOL

GENERAL INFORMATION

Measurement Uncertainty

The test system for conducted emissions is defined as the LISN, tuned receiver or spectrum analyzer, and coaxial cable. The test system for radiated emissions is defined as the antenna, the pre-amplifier, the spectrum analyzer and the coaxial cable. These test systems have a measurement uncertainty of ± 4.5 dB. The equipment comprising the test systems are calibrated on an annual basis.

Justification

The Equipment Under Test (EUT) is configured in a typical user arrangement in accordance with the manufacturer's instructions. A cable is connected to each available port and either terminated with a peripheral into its characteristic impedance or left unterminated. When appropriate, the cables are manually manipulated with respect to each other to obtain maximum emissions from the unit.

CONDUCTED EMISSIONS

The final level, expressed in dB μ V, is arrived at by taking the reading directly from the EMI receiver. This level is compared directly to the FCC limit.

To convert between dB μ V and μ V, the following conversions apply:

$$\text{dB}\mu\text{V} = 20(\log \mu\text{V})$$

$$\mu\text{V} = \text{Inverse log}(\text{dB}\mu\text{V}/20)$$

RADIATED EMISSIONS

The final level, expressed in dB μ V/m, is arrived at by taking the reading from the spectrum analyzer (Level dB μ V) and adding the antenna correction factor and cable loss factor (Factor dB) to it. This result then has the FCC limit subtracted from it to provide the Delta which gives the tabular data as shown in the data sheets in Attachment B. The amplifier gain is automatically accounted for by using an analyzer offset.

Example:

Frequency (MHz)	Level (dB μ V)	+	Factor & Cable (dB)	=	Final (dB μ V/m)	-	FCC B Limit (dB μ V/m)	=	Delta FCC B (dB)
32.21	13.9	+	16.3	=	30.2	-	40.0	=	-9.8

DETAILS OF TEST PROCEDURES

General Standard Information

The test methods used comply with ANSI C63.4-1992 - "Methods of Measurement of Radio-Noise Emissions from Low-Voltage Electrical and Electronic Equipment in the Range of 9 kHz to 40 GHz."

Conducted Emissions

Conducted emissions on the 60 Hz power interface of the EUT are measured in the frequency range of 450 kHz to 30 MHz. The measurements are performed using a receiver, which has CISPR characteristic bandwidth and quasi-peak detection, and a Line Impedance Stabilization Network (LISN), with 50 Ω /50 μ H (CISPR 16) characteristics. Table top equipment is placed on a non-conducting table 80 centimeters above the floor and is positioned 40 centimeters from the vertical ground plane (wall) of the screen room. In some cases, a pre-scan using a spectrum analyzer is initially performed on the units comprising the system under test to locate the highest emissions. If the minimum passing margin appears to be less than 20 dB with a peak mode measurement, the emissions are re-measured using a tuned receiver or spectrum analyzer with quasi-peak and average detection and recorded on the data sheets.

Radiated Emissions

Radiated emissions from the EUT are measured in the frequency range of 30 to 1000 MHz using a spectrum analyzer and appropriate broadband linearly polarized antennas. Measurements between 30 MHz and 1000 MHz are made with 120 kHz/6 dB bandwidth and quasi-peak detection and measurements above 1000 MHz are made with a 1 MHz/6 dB bandwidth and peak detection. Table top equipment is placed on a 1.0 X 1.5 meter non-conducting table 80 centimeters above the ground plane. Floor standing equipment is placed directly on the turntable/ground plane. Interface cables that are closer than 40 centimeters to the ground plane are bundled in the center in a serpentine fashion so they are at least 40 centimeters from the ground plane. Cables to simulators/testers (if used in this test) are routed through the center of the table and to a screen room located outside the test area. The antenna is positioned 3 meters horizontally from the EUT. To locate maximum emissions from the test sample the antenna is varied in height from 1 to 4 meters, measurement scans are made with both horizontal and vertical antenna polarizations and the EUT are rotated 360 degrees. Intentional radiators are rotated through three orthogonal axes to determine the attitude that maximizes the emissions.