

ISS	ECO NO.	DATE	CHG. BY	DESCRIPTION (LO: OD->ND)	APPROVED	VENDOR	SCALE	TOLERANCE	ORG DATA	2003/01/20	 鴻友科技股份有限公司			
						1	UNITS	X. ±	ORG BY	Sam. Chen	TITLE: PCBA, MAIN BOARD, 802.11B CardBUS			
						2	MATERIAL	.X ±	CHK BY		WH. USED: RTL8180+PHILIPS			
						3	FINISH	.XX ±	CONCURRED		DWG NO	59-131-01020	ISS	
REVISIONS									APPROVED		P/N	59-131-01020	P 2 of 6	X2
LO:LOCATION, OD:OLD DATA, ND:NEW DATA						FILE NAME:			FINAL APPR					

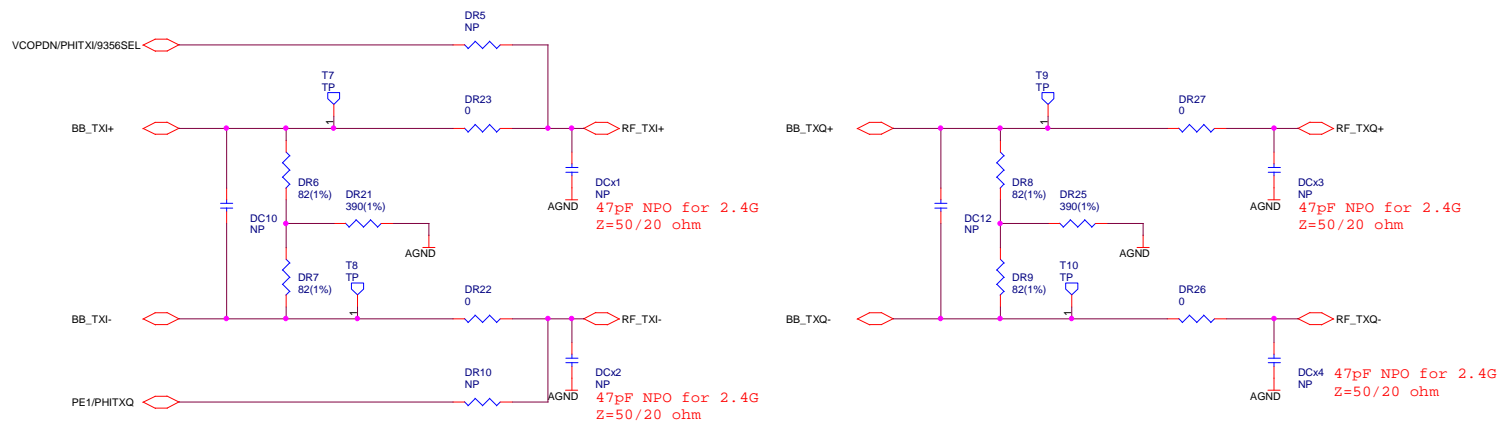

1. For analog TXIQ interface, DR6, DR7, DR8, DR9, DR21, DR22, DR23, DR25, DR26 and DR27 must be mounted, discard DR5 and DR10 . And Setting the EEPROM, DigitalPHY=0. Analog interface is the default selection.
2. For digital TXIQ interface, DR5 and DR10 must be mounted, discard DR6, DR7, DR8, DR9, DR21, DR22, DR23, DR25, DR26 and DR27. And setting the EEPROM, DigitalPHY=1.

Title		
PCBA,MAIN BOARD,802.11B CardBUS (BB2RF)		
Size	Document Number	Rev
	59-131-01020	X2
Date:	Thursday, April 24, 2003	Sheet 3 of 6

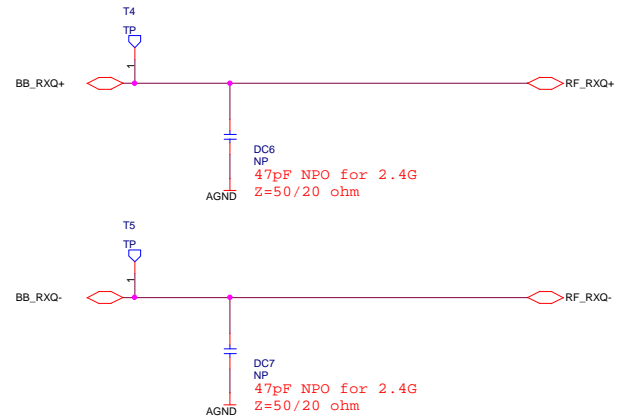
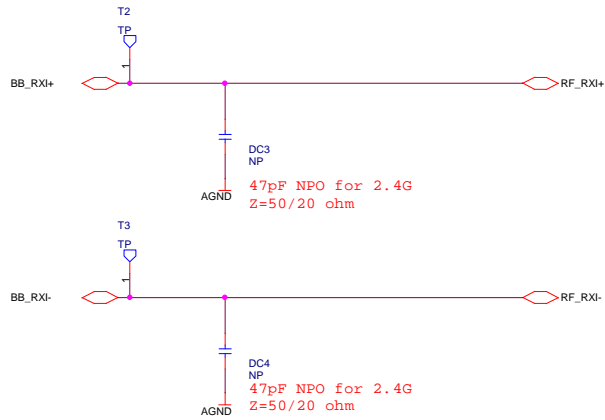