



Test Report

Product Name : BT-DH
Model No. : MBT-D120
FCC ID. : HWF-MBTD120

Applicant : Mustek Systems Inc.
Address : No.25, R&D Road II, Science-Based Industrial
Park, Hsin-Chu, Taiwan, R.O.C.

Date of Receipt : 2005/02/18
Issued Date : 2005/03/03
Report No. : 052H040-F-R02-T

The test results relate only to the samples tested.
The test report shall not be reproduced except in full without the written approval of QuieTek Corporation.

Test Report Certification

Issued Date : 2005/03/03

Report No. : 052H040-F-R02-T



Product Name : BT-DH
Applicant : Mustek Systems Inc.
Address : No.25, R&D Road II, Science-Based Industrial Park,
Hsin-Chu, Taiwan, R.O.C.
Manufacturer : Mustek Systems Inc.
Model No. : MBT-D120
FCC ID. : HWF-MBTD120
Rated Voltage : AC 120 V / 60 Hz
EUT Voltage : DC 5V
Trade Name : Mustek
Applicable Standard : FCC CFR Title 47 Part 15 Subpart C Section 15.247: 2003
Test Result : Complied

The test results relate only to the samples tested.

The test report shall not be reproduced except in full without the written approval of Quietek Corporation.

Documented By : Carol Tsai

(Carol Tsai)

Tested By : Louis Hsu

(Louis Hsu)

Approved By : James Chang

(James Chang)

TABLE OF CONTENTS

Description	Page
1. General Information	5
1.1. EUT Description	5
1.2. Operational Description	7
1.3. Test Mode	8
1.4. Tested System Details	9
1.5. Configuration of tested System	10
1.6. EUT Exercise Software	11
1.7. Test Facility	12
2. Conducted Emission	14
2.1. Test Equipment	14
2.2. Test Setup	14
2.3. Limits	15
2.4. Test Procedure	15
2.5. Test Specification	15
2.6. Test Result	16
2.7. Test Photo	18
3. Peak Power Output	19
3.1. Test Equipment	19
3.2. Test Setup	19
3.3. Limits	19
3.4. Test Specification	19
3.5. Test Result	20
4. Radiated Emission	21
4.1. Test Equipment	21
4.2. Test Setup	21
4.3. Limits	22
4.4. Test Procedure	22
4.5. Test Specification	22
4.6. Test Result	23
4.7. Test Photo	35
5. Band Edge	37
5.1. Test Equipment	37
5.2. Test Setup	38
5.3. Limits	38
5.4. Test Procedure	39
5.5. Test Specification	39
5.6. Test Result	40
6. Channel of Number	44
6.1. Test Equipment	44
6.2. Test Setup	44
6.3. Limits	44
6.4. Test Specification	44
6.5. Test Result	45
7. Channel Separation	46

7.1.	Test Equipment.....	46
7.2.	Test Setup	46
7.3.	Limits	46
7.4.	Test Specification.....	46
7.5.	Test Result.....	47
8.	Occupied Bandwidth.....	48
8.1.	Test Equipment.....	48
8.2.	Test Setup	48
8.3.	Limits	48
8.4.	Test Specification.....	48
8.5.	Test Result.....	49
9.	Dwell Time.....	50
9.1.	Test Equipment.....	50
9.2.	Test Setup	50
9.3.	Limits	50
9.4.	Test Specification.....	50
9.5.	Test Result.....	51
Attachement.....		54
	EUT Photograph.....	54

1. General Information

1.1. EUT Description

Product Name	BT-DH
Trade Name	Mustek
Model No.	MBT-D120
FCC ID	HWF-MBTD120
Frequency Range	2402~2480MHz
Channel Number	79
Type of Modulation	Frequency Hopping Spread Spectrum
Antenna Gain	-2dBi
Channel Control	Auto
Antenna Type	Soldered on PCB

Working Frequency of Each Channel							
Channel	Frequency	Channel	Frequency	Channel	Frequency	Channel	Frequency
Channel 00	2402 MHz	Channel 20	2422 MHz	Channel 40	2442 MHz	Channel 60	2462 MHz
Channel 01	2403 MHz	Channel 21	2423 MHz	Channel 41	2443 MHz	Channel 61	2463 MHz
Channel 02	2404 MHz	Channel 22	2424 MHz	Channel 42	2444 MHz	Channel 62	2464 MHz
Channel 03	2405 MHz	Channel 23	2425 MHz	Channel 43	2445 MHz	Channel 63	2465 MHz
Channel 04	2406 MHz	Channel 24	2426 MHz	Channel 44	2446 MHz	Channel 64	2466 MHz
Channel 05	2407 MHz	Channel 25	2427 MHz	Channel 45	2447 MHz	Channel 65	2467 MHz
Channel 06	2408 MHz	Channel 26	2428 MHz	Channel 46	2448 MHz	Channel 66	2468 MHz
Channel 07	2409 MHz	Channel 27	2429 MHz	Channel 47	2449 MHz	Channel 67	2469 MHz
Channel 08	2410 MHz	Channel 28	2430 MHz	Channel 48	2450 MHz	Channel 68	2470 MHz
Channel 09	2411 MHz	Channel 29	2431 MHz	Channel 49	2451 MHz	Channel 69	2471 MHz
Channel 10	2412 MHz	Channel 30	2432 MHz	Channel 50	2452 MHz	Channel 70	2472 MHz
Channel 11	2413 MHz	Channel 31	2433 MHz	Channel 51	2453 MHz	Channel 71	2473 MHz
Channel 12	2414 MHz	Channel 32	2434 MHz	Channel 52	2454 MHz	Channel 72	2474 MHz
Channel 13	2415 MHz	Channel 33	2435 MHz	Channel 53	2455 MHz	Channel 73	2475 MHz
Channel 14	2416 MHz	Channel 34	2436 MHz	Channel 54	2456 MHz	Channel 74	2476 MHz
Channel 15	2417 MHz	Channel 35	2437 MHz	Channel 55	2457 MHz	Channel 75	2477 MHz
Channel 16	2418 MHz	Channel 36	2438 MHz	Channel 56	2458 MHz	Channel 76	2478 MHz
Channel 17	2419 MHz	Channel 37	2439 MHz	Channel 57	2459 MHz	Channel 77	2479 MHz
Channel 18	2420 MHz	Channel 38	2440 MHz	Channel 58	2460 MHz	Channel 78	2480 MHz
Channel 19	2421 MHz	Channel 39	2441 MHz	Channel 59	2461 MHz		

The system receivers have input bandwidths that match the hopping channel bandwidths of their corresponding transmitters and shift frequencies in synchronization with the transmitted signals. Frequency hopping spread spectrum systems are not required to employ all available hopping channels during each transmission. The transmitter is presented with a continuous data stream. In addition, a system employing short transmission bursts must comply with the definition of a frequency hopping system and must distribute its 79 channels and over the minimum number of hopping channels (75 channels).

The incorporation of intelligence within a frequency hopping spread spectrum system that permits the system to recognize other users within the spectrum band so that it individually and independently chooses and adapts its hopsets to avoid hopping on occupied channels is permitted. The coordination of frequency hopping systems in any other manner for the express purpose of avoiding the simultaneous occupancy of individual hopping frequencies by multiple transmitters is not permitted.

Note:

1. This device is a BT-DH included a 2.4GHz receiving function, and 2.4GHz transmitting function.
2. These tests were conducted on a sample of the equipment for the purpose of demonstrating compliance with Part 15 Subpart C Paragraph 15.247 for spread spectrum devices.
3. Regards to the frequency band operation; the lowest , middle and highest frequency of channel were selected to perform the test, and then shown on this report.
4. This device is a composite device in accordance with Part 15 regulations. The function receiving was measured and made a test report that the report number is 052H040-F-R01-R under Declaration of Conformity.

1.2. Operational Description

The EUT is an USB interface BT-DH with 79 channels.

This device provides wireless technology that revolutionizes personal connectivity. It is the solution for the seamless integration of Bluetooth technology into personal computer enabling short-range wireless connections between desktop/laptop computers, Bluetooth-enabled peripherals (printers, faxes,....), portable handheld devices, and connectivity to the Internet.

1.3. Test Mode

QuieTek has verified the construction and function in typical operation. All the test modes were carried out with the EUT in normal operation, which was shown in this test report and defined as:

Pre-Test Mode	
EMI	Mode 1: Transmit
Final Test Mode	
TX	Mode 1: Transmit

1.4. Tested System Details

The types for all equipments, plus descriptions of all cables used in the tested system (including inserted cards) are:

	Product	Manufacturer	Model No.	Serial No.	FCC ID	Power Cord
1	PC	COMPAQ	PD1100	SG30801014	DoC	Non-Shielded, 1.8m
2	Monitor	SAMPO	KM-522	S5110119ET00953	DoC	Non-Shielded, 1.8m
3	Keyboard	HP	SK-2502	M971237059	DoC	--
4	Mouse	IBM	M-SAU-IBM6	23-029334	DoC	--
5	BT-DH	Mustek	MBT-H120	N/A	HWF-MBTH120	--
6	Printer	HP	C2642A	MY75N1D2Y1	DoC	Non-Shielded, 0.7m
7	Modem	ACEEX	DM-1414	980033034	DoC	Non-Shielded, 1.6m
8	External Storage Enclosure	MACPOWER	Laureate Super 800	N/A	DoC	--
9	2.5" HDD Portable Enclosure	Terabit	TB-25U2	N/A	DoC	--
10	Portable Hard DISK	Top Disk Enterprise	Me-910	220948	DoC	--
11	Portable Hard DISK	Top Disk Enterprise	Me-910	220949	DoC	--
12	Portable Hard DISK	Top Disk Enterprise	Me-910	220951	DoC	--
13	Walkman	AIWA	US-J202	HSA20201	DoC	--
14	Microphone & Earphone	TOKTO	SX-MI	N/A	DoC	--
15	Microphone & Earphone	TOKTO	SX-MI	N/A	DoC	--

1.5. Configuration of tested System

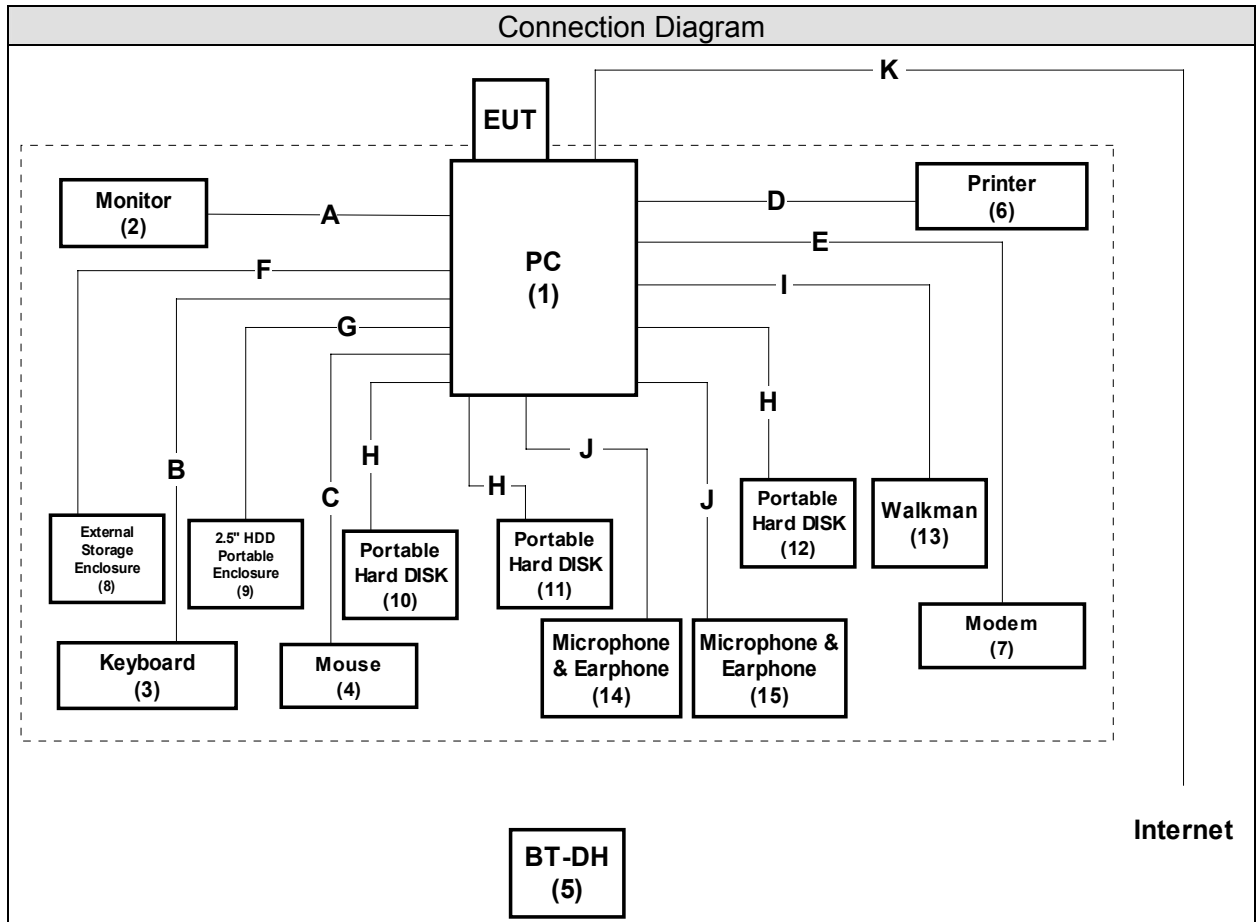

Signal Cable Type		Signal cable Description
A	VGA Cable	Shielded, 1.6m, one ferrite core bonded
B	Keyboard Cable	Shielded, 1.8m
C	Mouse Cable	Shielded, 1.8m
D	Printer Cable	Shielded, 1.2m
E	Modem Cable	Shielded, 1.5m
F	USB2.0 External Storage Enclosure Cable	Shielded, 1.8m
G	USB2.0 2.5" HDD Portable Enclosure Cable	Shielded, 1.6m
H	USB2.0 Portable Hard DISK Cable	Shielded, 1.6m, 3 Pcs
I	Walkman Cable	Non-Shielded, 1.6m
J	Microphone & Earphone Cable	Non-Shielded, 1.2m, 2 Pcs
K	LAN Cable	Non-Shielded, 10m

1.6. EUT Exercise Software

1	Setup the EUT and simulators as shown on 1.5.
2	Turn on the power of all equipment.
3	Boot the PC from Hard Disk.
4	Data will be communicated between computer and EUT.
5	All the peripheral will be retrieved during the test.
6	Repeat the above procedure (4) to (5).

1.7. Test Facility

Ambient conditions in the laboratory:

Items	Test Item	Required (IEC 68-1)	Actual
Temperature (°C)	FCC PART 15 C 15.207 Conducted Emission	15 - 35	22
Humidity (%RH)		25 - 75	55
Barometric pressure (mbar)		860 - 1060	950-1000
Temperature (°C)	FCC PART 15 C 15.247 Band Edge (FHSS)	15 - 35	22
Humidity (%RH)		25 - 75	55
Barometric pressure (mbar)		860 - 1060	950-1000
Temperature (°C)	FCC PART 15 C 15.247 Channel Of Number (FHSS)	15 - 35	22
Humidity (%RH)		25 - 75	55
Barometric pressure (mbar)		860 - 1060	950-1000
Temperature (°C)	FCC PART 15 C 15.247 Channel Separation (FHSS)	15 - 35	20
Humidity (%RH)		25 - 75	55
Barometric pressure (mbar)		860 - 1060	950-1000
Temperature (°C)	FCC PART 15 C 15.247 Dwell Time (FHSS)	15 - 35	20
Humidity (%RH)		25 - 75	55
Barometric pressure (mbar)		860 - 1060	950-1000
Temperature (°C)	FCC PART 15 C 15.247 Peak Power Output (FHSS)	15 - 35	2
Humidity (%RH)		25 - 75	50
Barometric pressure (mbar)		860 - 1060	950-1000
Temperature (°C)	FCC PART 15 C 15.247 Radiated Emission (FHSS)	15 - 35	22
Humidity (%RH)		25 - 75	55
Barometric pressure (mbar)		860 - 1060	950-1000

Site Description:

January 24, 2005 File on
Federal Communications Commission
Laboratory Division
7435 Oakland Mills Road
Columbia, MD 21046
Registration Number: 365520



1313

ILAC MRA

Accredited by CNLA
Accreditation Number: 1313
Effective through: September 27 , 2007

Accredited by NVLAP
NVLAP Lab Code: 200347-0
Effective through: September 30, 2005



Site Name: Quietek Corporation

Site Address: No.75-1, Wang-Yeh Valley, Yung-Hsing,
Chiung-Lin, Hsin-Chu County,
Taiwan, R.O.C.
TEL : 886-3-592-8858 / FAX : 886-3-592-8859
E-Mail : service@quietek.com

2. Conducted Emission

2.1. Test Equipment

The following test equipment are used during the test:

Item	Equipment	Manufacturer	Model No. / Serial No.	Last Cal.	Remark
1	Test Receiver	R & S	ESCS 30/825442/018	Sep., 2004	
2	Artificial Mains Network	R & S	ENV4200/848411/10	Feb., 2005	Peripheral
3	LISN	R & S	ESH3-Z5/825562/002	Feb., 2005	EUT
4	Pulse Limiter	R & S	ESH3-Z2/357.8810.52	Feb., 2005	
5	No.2 Shielded Room			N/A	

Note: All equipment upon which need to calibrated are with calibration period of 1 year.

2.2. Test Setup

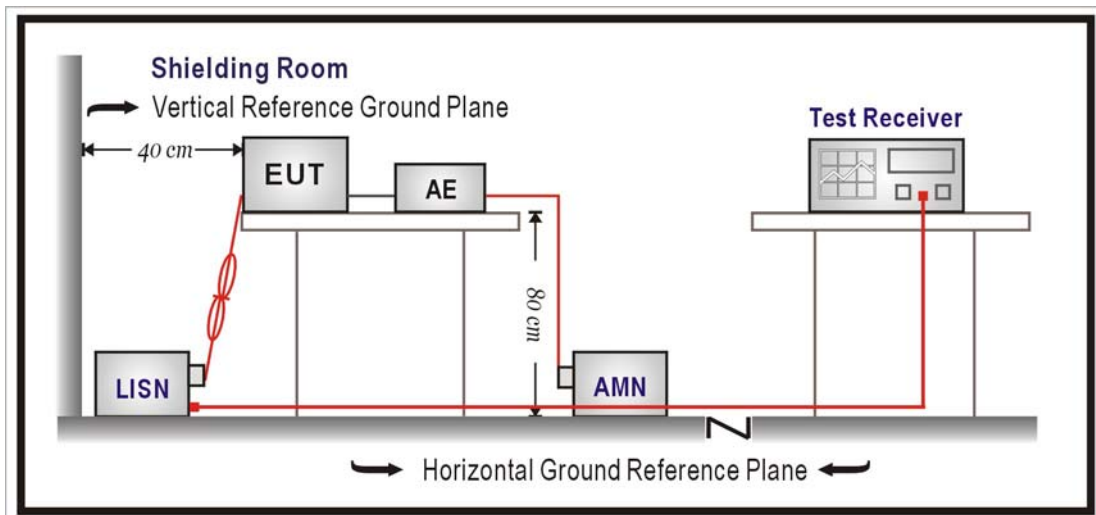

2.3. Limits

FCC Part 15 Subpart C Paragraph 15.207 Limits (dBuV)		
Frequency MHz	QP	AV
0.15 - 0.50	66-56	56-46
0.50-5.0	56	46
5.0 - 30	60	50

Remarks : In the above table, the tighter limit applies at the band edges.

2.4. Test Procedure

The EUT and simulators are connected to the main power through a line impedance stabilization network (L.I.S.N.). This provides a 50 ohm /50uH coupling impedance for the measuring equipment. The peripheral devices are also connected to the main power through a LISN that provides a 50ohm/50uH coupling impedance with 50ohm termination. (Please refers to the block diagram of the test setup and photographs.)

Both sides of A.C. line are checked for maximum conducted interference. In order to find the maximum emission, the relative positions of equipment and all of the interface cables must be changed according to ANSI C63.4: 2003 on conducted measurement.

Conducted emissions were invested over the frequency range from 0.15MHz to 30MHz using a receiver bandwidth of 9kHz.

2.5. Test Specification

According to FCC Part 15 Subpart C Paragraph 15.207: 2003

2.6. Test Result

Product	BT-DH		
Test Item	Conducted Emission		
Test Mode	Mode 1: Transmit		
Date of Test	2005/03/03	Test Site	No.2 Shielded Room

Frequency MHz	Cable Loss dB	LISN Factor dB	Reading Level dBuV	Emission Level dBuV	Limits dBuV
=====					
LINE 1					
Quasi-Peak					
* 0.234	0.10	0.10	41.82	42.02	62.32
0.352	0.10	0.10	31.66	31.86	58.90
0.944	0.11	0.10	21.74	21.95	56.00
2.244	0.13	0.12	23.26	23.51	56.00
7.204	0.19	0.33	26.69	27.21	60.00
15.592	0.31	0.71	28.67	29.69	60.00
Average					
* 0.234	0.10	0.10	36.50	36.70	52.31
0.352	0.10	0.10	27.30	27.50	48.92
0.944	0.11	0.10	21.50	21.71	46.00
2.244	0.13	0.12	22.20	22.45	46.00
7.204	0.19	0.33	23.70	24.22	50.00
15.592	0.31	0.71	26.70	27.72	50.00

Note:

1. All Reading Levels are Quasi-Peak and Average value.
2. " * ", means this data is the worst emission level.
3. Emission Level = Reading Level + LISN Factor + Cable Loss.

Product	BT-DH		
Test Item	Conducted Emission		
Test Mode	Mode 1: Transmit		
Date of Test	2005/03/03	Test Site	No.2 Shielded Room

Frequency	Cable Loss	LISN Factor	Reading Level	Emission Level	Limits
MHz	dB	dB	dBuV	dBuV	dBuV
=====					
LINE 2					
Quasi-Peak					
* 0.236	0.10	0.10	44.21	44.41	62.23
0.353	0.10	0.10	31.86	32.06	58.89
0.943	0.11	0.10	23.31	23.52	56.00
1.415	0.12	0.10	25.34	25.56	56.00
7.911	0.20	0.27	27.56	28.04	60.00
14.998	0.30	0.50	30.39	31.18	60.00
Average					
* 0.236	0.10	0.10	36.60	36.80	52.24
0.353	0.10	0.10	24.80	25.00	48.89
0.943	0.11	0.10	22.70	22.91	46.00
1.415	0.12	0.10	21.00	21.22	46.00
7.911	0.20	0.27	24.00	24.48	50.00
14.998	0.30	0.50	28.60	29.39	50.00

Note:

1. All Reading Levels are Quasi-Peak and Average value.
2. " * ", means this data is the worst emission level.
3. Emission Level = Reading Level + LISN Factor + Cable Loss.

3. Peak Power Output

3.1. Test Equipment

The following test equipment are used during the test:

Item	Equipment	Manufacturer	Model No. / Serial No.	Last Cal.
1	Power Meter	Agilent	E4416A / GB41291630	May, 2004
2	Power Sensor	Agilent	E9323A / US40411166	Apr., 2004
3	No.1 OATS			Sep., 2004

Note: All equipment upon which need to calibrated are with calibration period of 1 year.

3.2. Test Setup

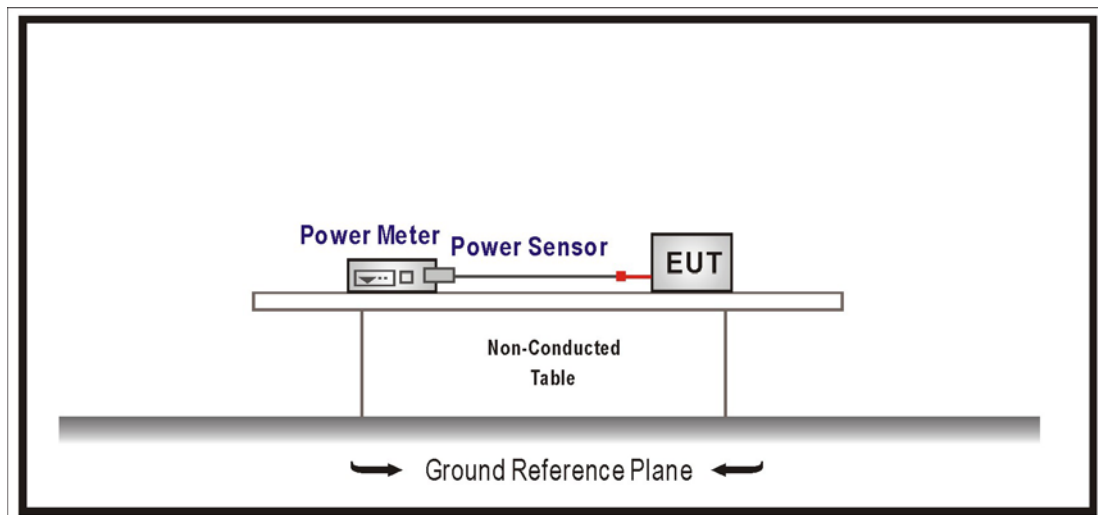

3.3. Limits

For frequency hopping systems operating in the 902-928 MHz band: 1 Watt for systems employing at least 50 hopping channels; and, 0.25 Watts for systems employing less than 50 hopping channels.

For frequency hopping systems in the 2400-2483.5 MHz band employing at least 75 hopping channels, and all frequency hopping systems in the 5725-5850 MHz band: 1Watt. For all other frequency hopping systems in the 2400-2483.5 MHz band: 0.125 Watt.

3.4. Test Specification

According to FCC Part 15 Subpart C Paragraph 15.247: 2003

3.5. Test Result

Product	BT-DH		
Test Item	Peak Power Output		
Test Mode	Mode 1: Transmit		
Date of Test	2005/03/03	Test Site	No.1 OATS

Channel No.	Frequency (MHz)	Measure Level (dBm)	Limit (dBm)	Result
00	2402.00	-4.10	1Watt = 30 dBm	Pass
39	2441.00	-3.35	1Watt= 30 dBm	Pass
78	2480.00	-3.20	1Watt= 30 dBm	Pass

4. Radiated Emission

4.1. Test Equipment

The following test equipment are used during the test:

Item		Equipment	Manufacturer	Model No. / Serial No.	Last Cal.
1	X	Test Receiver	R & S	ESCS 30 / 825442/017	Jan., 2005
2	X	Spectrum Analyzer	Advantest	R3261C / 81720266	N/A
3	X	Pre-Amplifier	HP	8447D / 2944A09276	N/A
4	X	Bilog Antenna	Chase	CBL6112B / 2455	Sep., 2004
5	X	Spectrum Analyzer	R & S	FSP40 / 100005	Aug., 2004
6	X	Pre-Amplifier	HP	8449B / 3008A01123	Feb., 2005
7	X	Horn Antenna	Schwarzbeck	BBHA 9120D / BBHA9120D312	Jul., 2004
8		No.1 OATS			Sep., 2004

- Note: 1. All equipments that need to calibrate are with calibration period of 1 year.
 2. Mark "X" test instruments are used to measure the final test results.

4.2. Test Setup

Under 1GHz Test Setup:

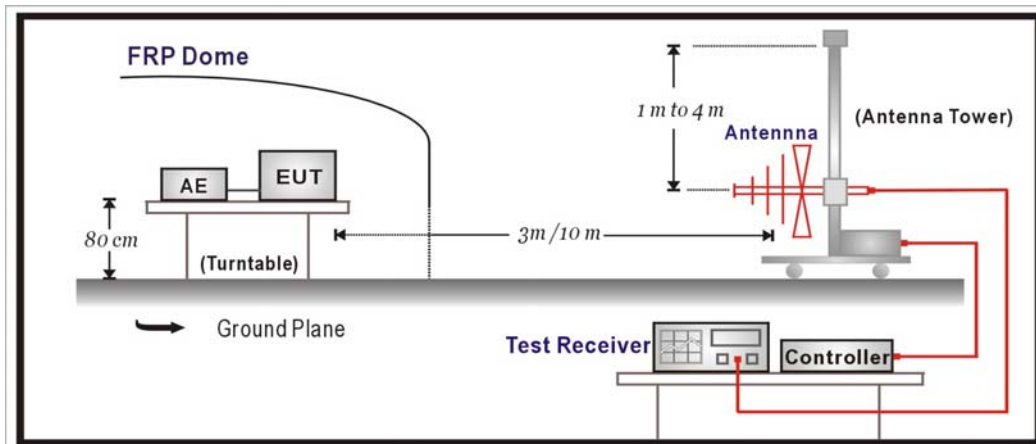

Above 1GHz Test Setup:

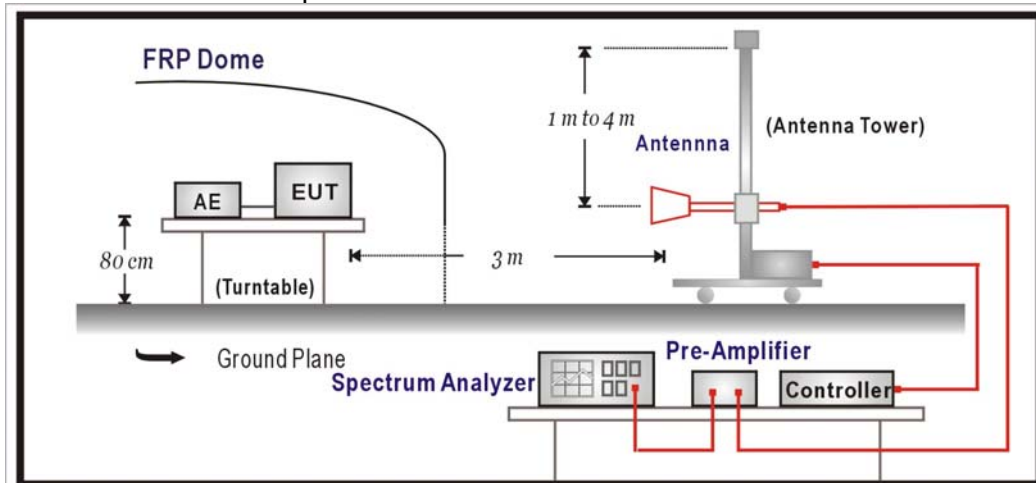

4.3. Limits

Emissions radiated outside of the specified frequency bands, except for harmonics, shall be attenuated by at least 20dB below the level of the fundamental or to the general radiated emission limits in paragraph 15.209, whichever is the lesser attenuation.

FCC Part 15 Subpart C Paragraph 15.209 Limits		
Frequency MHz	uV/m	dBuV/m
30-88	100	40
88-216	150	43.5
216-960	200	46
Above 960	500	54

- Remarks :
1. RF Voltage (dBuV) = 20 log RF Voltage (uV)
 2. In the Above Table, the tighter limit applies at the band edges.
 3. Distance refers to the distance in meters between the measuring instrument antenna and the closed point of any part of the device or system.

4.4. Test Procedure

The EUT and its simulators are placed on a turn table which is 0.8 meter above ground. The turn table can rotate 360 degrees to determine the position of the maximum emission level. The antenna can move up and down between 1 meter and 4 meters to find out the maximum emission level.

Both horizontal and vertical polarization of the antenna are set on measurement. In order to find the maximum emission, all of the interface cables must be manipulated according to ANSI C63.4:2003 on radiated measurement.

On any frequency or frequencies below or equal to 1000 MHz, the limits shown are based on measuring equipment employing a quasi-peak detector function and on any frequency or frequencies above 1000 MHz the radiated limits shown are based upon the use of measurement instrumentation employing an average detector function. When average radiated emission measurement are included emission measurement below 1000 MHz, there also is a limit on the radio frequency emissions, as measured using instrumentation with a peak detector function, corresponding to 20 dB above the maximum permitted average limit. The bandwidth below 1GHz setting on the field strength meter is 120 kHz and above 1GHz is 1MHz.

4.5. Test Specification

According to FCC Part 15 Subpart C Paragraph 15.247: 2003

4.6. Test Result

Product	BT-DH		
Test Item	Radiated Emission		
Test Mode	Mode 1: Transmit		
Date of Test	2005/03/03	Test Site	No.1 OATS

Channel 00

Frequency	Cable Loss	Probe Factor	PreAMP	Reading Level	Emission Level	Margin	Limit
MHz	dB	dB/m	dB	dBuV	dBuV/m	dB	dBuV/m

=====

Horizontal

Peak

4804.020	4.23	31.19	31.95	49.24	52.71	21.29	74.00
7204.010	5.61	35.88	32.71	31.37	40.15	33.85	74.00
9604.000	6.98	38.03	31.98	28.77 <	41.80	32.20	74.00
12004.00	8.36	38.63	31.38	29.17 <	44.78	29.22	74.00

Note:

1. All Readings below 1GHz are Quasi-Peak, above are performed with peak and/or average measurements as necessary.
2. Receiver setting (Peak Detector) : RBW:1MHz; VBW:1MHz; Span:100MHz.
3. Receiver setting (AVG Detector) : RBW:1MHz; VBW:30Hz; Span:20MHz.
4. Emission Level = Reading Level + Probe Factor + Cable Loss – PreAMP.
5. The average measurement was not performed when the peak measured data under the limit of average detection. If the readings given are average, peak measurement should also be supplied.

Product	BT-DH		
Test Item	Radiated Emission		
Test Mode	Mode 1: Transmit		
Date of Test	2005/03/03	Test Site	No.1 OATS

Channel 00

Frequency	Cable Loss	Probe Factor	PreAMP	Reading Level	Emission Level	Margin	Limit
MHz	dB	dB/m	dB	dBuV	dBuV/m	dB	dBuV/m

=====

Vertical

Peak

4804.010	4.23	31.19	31.95	45.66	49.13	24.87	74.00
7204.000	5.61	35.88	32.71	29.60	38.38	35.62	74.00
9604.100	6.98	38.03	31.98	29.28	< 42.31	31.69	74.00
12004.00	8.36	38.63	31.38	29.15	< 44.76	29.24	74.00

Note:

1. All Readings below 1GHz are Quasi-Peak, above are performed with peak and/or average measurements as necessary.
2. Receiver setting (Peak Detector) : RBW:1MHz; VBW:1MHz; Span:100MHz.
3. Receiver setting (AVG Detector) : RBW:1MHz; VBW:30Hz; Span:20MHz.
4. Emission Level = Reading Level + Probe Factor + Cable Loss – PreAMP.
5. The average measurement was not performed when the peak measured data under the limit of average detection. If the readings given are average, peak measurement should also be supplied.

Product	BT-DH		
Test Item	Radiated Emission		
Test Mode	Mode 1: Transmit		
Date of Test	2005/03/03	Test Site	No.1 OATS

Channel 39

Frequency	Cable Loss	Probe Factor	PreAMP	Reading Level	Emission Level	Margin	Limit
MHz	dB	dB/m	dB	dBuV	dBuV/m	dB	dBuV/m

Horizontal

Peak

4882.000	4.28	31.35	31.95	49.82	53.50	20.50	74.00
7322.980	5.68	36.12	32.58	30.32	39.54	34.46	74.00
9763.990	7.07	38.07	31.66	28.84	< 42.32	31.68	74.00
12205.02	8.48	38.50	31.20	28.77	< 44.54	29.46	74.00

Note:

1. All Readings below 1GHz are Quasi-Peak, above are performed with peak and/or average measurements as necessary.
- 2 Receiver setting (Peak Detector) : RBW:1MHz; VBW:1MHz; Span:100MHz.
3. Receiver setting (AVG Detector) : RBW:1MHz; VBW:30Hz; Span:20MHz.
4. Emission Level = Reading Level + Probe Factor + Cable Loss – PreAMP.
5. The average measurement was not performed when the peak measured data under the limit of average detection. If the readings given are average, peak measurement should also be supplied.

Product	BT-DH		
Test Item	Radiated Emission		
Test Mode	Mode 1: Transmit		
Date of Test	2005/03/03	Test Site	No.1 OATS

Channel 39

Frequency	Cable Loss	Probe Factor	PreAMP	Reading Level	Emission Level	Margin	Limit
MHz	dB	dB/m	dB	dBuV	dBuV/m	dB	dBuV/m
=====							

Vertical

Peak

4882.000	4.28	31.35	31.95	46.13	49.81	24.19	74.00
7323.000	5.68	36.12	32.58	29.54	38.76	35.24	74.00
9763.970	7.07	38.07	31.66	30.40	< 43.88	30.12	74.00
12205.00	8.48	38.50	31.20	28.32	< 44.09	29.91	74.00

Note:

1. All Readings below 1GHz are Quasi-Peak, above are performed with peak and/or average measurements as necessary.
- 2 Receiver setting (Peak Detector) : RBW:1MHz; VBW:1MHz; Span:100MHz.
3. Receiver setting (AVG Detector) : RBW:1MHz; VBW:30Hz; Span:20MHz.
4. Emission Level = Reading Level + Probe Factor + Cable Loss – PreAMP.
5. The average measurement was not performed when the peak measured data under the limit of average detection. If the readings given are average, peak measurement should also be supplied.

Product	BT-DH		
Test Item	Radiated Emission		
Test Mode	Mode 1: Transmit		
Date of Test	2005/03/03	Test Site	No.1 OATS

Channel 78

Frequency	Cable Loss	Probe Factor	PreAMP	Reading Level	Emission Level	Margin	Limit
MHz	dB	dB/m	dB	dBuV	dBuV/m	dB	dBuV/m

Horizontal

Peak

4960.000	4.32	31.47	31.96	46.71	50.55	23.45	74.00
7440.000	5.75	36.36	32.46	29.84	39.49	34.51	74.00
9919.900	7.16	38.11	31.34	29.18	< 43.11	30.89	74.00
12400.00	8.59	38.36	31.01	28.13	< 44.07	29.93	74.00

Note:

1. All Readings below 1GHz are Quasi-Peak, above are performed with peak and/or average measurements as necessary.
- 2 Receiver setting (Peak Detector) : RBW:1MHz; VBW:1MHz; Span:100MHz.
3. Receiver setting (AVG Detector) : RBW:1MHz; VBW:30Hz; Span:20MHz.
4. Emission Level = Reading Level + Probe Factor + Cable Loss – PreAMP.
5. The average measurement was not performed when the peak measured data under the limit of average detection. If the readings given are average, peak measurement should also be supplied.

Product	BT-DH		
Test Item	Radiated Emission		
Test Mode	Mode 1: Transmit		
Date of Test	2005/03/03	Test Site	No.1 OATS

Channel 78

Frequency	Cable Loss	Probe Factor	PreAMP	Reading Level	Emission Level	Margin	Limit
MHz	dB	dB/m	dB	dBuV	dBuV/m	dB	dBuV/m

=====

Vertical

Peak

4960.000	4.32	31.47	31.96	47.31	51.15	22.85	74.00
7440.000	5.75	36.36	32.46	29.30	38.95	35.05	74.00
9920.000	7.16	38.11	31.34	28.25	< 42.18	31.82	74.00
12400.00	8.59	38.36	31.01	27.95	< 43.89	30.11	74.00

Note:

1. All Readings below 1GHz are Quasi-Peak, above are performed with peak and/or average measurements as necessary.
- 2 Receiver setting (Peak Detector) : RBW:1MHz; VBW:1MHz; Span:100MHz.
3. Receiver setting (AVG Detector) : RBW:1MHz; VBW:30Hz; Span:20MHz.
4. Emission Level = Reading Level + Probe Factor + Cable Loss – PreAMP.
5. The average measurement was not performed when the peak measured data under the limit of average detection. If the readings given are average, peak measurement should also be supplied.

Product	BT-DH		
Test Item	Radiated Emission		
Test Mode	Mode 1: Transmit		
Date of Test	2005/03/03	Test Site	No.1 OATS

Channel 00

Frequency	Cable Loss	Probe Factor	PreAMP	Reading Level	Emission Level	Margin	Limit
MHz	dB	dB/m	dB	dBuV	dBuV/m	dB	dBuV/m

=====

Horizontal

Quasi-Peak

496.990	1.02	20.87	22.60	37.37	36.66	9.34	46.00
562.110	1.12	22.18	22.60	38.45	39.15	6.85	46.00
* 630.010	1.22	23.54	22.60	39.59	41.75	4.25	46.00
693.760	1.31	23.95	22.60	32.69	35.36	10.64	46.00
760.270	1.41	24.38	22.60	35.23	38.42	7.58	46.00
905.770	1.63	25.30	22.60	31.15	35.48	10.52	46.00

Note:

1. All Readings below 1GHz are Quasi-Peak, above are performed with peak and/or average measurements as necessary.
- 2 " * ", means this data is the worst emission level.
3. Emission Level = Reading Level + Probe Factor + Cable Loss – PreAMP.

Product	BT-DH		
Test Item	Radiated Emission		
Test Mode	Mode 1: Transmit		
Date of Test	2005/03/03	Test Site	No.1 OATS

Channel 00

Frequency MHz	Cable Loss dB	Probe Factor dB/m	PreAMP dB	Reading Level dBuV	Emission Level dBuV/m	Margin dB	Limit dBuV/m
=====							

Vertical

Quasi-Peak

85.430	0.41	16.99	22.60	37.66	32.46	7.54	40.00
201.830	0.59	13.93	22.60	37.69	29.60	13.90	43.50
496.990	1.02	19.92	22.60	32.07	30.41	15.59	46.00
630.010	1.22	21.15	22.60	37.30	37.07	8.93	46.00
* 760.270	1.41	21.63	22.60	38.69	39.13	6.87	46.00
898.840	1.62	23.78	22.60	32.11	34.91	11.09	46.00

Note:

1. All Readings below 1GHz are Quasi-Peak, above are performed with peak and/or average measurements as necessary.
- 2 " * ", means this data is the worst emission level.
3. Emission Level = Reading Level + Probe Factor + Cable Loss – PreAMP.

Product	BT-DH		
Test Item	Radiated Emission		
Test Mode	Mode 1: Transmit		
Date of Test	2005/03/03	Test Site	No.1 OATS

Channel 39

Frequency MHz	Cable Loss dB	Probe Factor dB/m	PreAMP dB	Reading Level dBuV	Emission Level dBuV/m	Margin dB	Limit dBuV/m
=====							

Horizontal

Quasi-Peak

496.990	1.02	20.87	22.60	39.17	38.46	7.54	46.00
562.110	1.12	22.18	22.60	39.45	40.15	5.85	46.00
* 630.001	1.22	23.54	22.60	41.79	43.95	2.05	46.00
696.530	1.32	23.97	22.60	32.94	35.63	10.37	46.00
760.270	1.41	24.38	22.60	35.63	38.82	7.18	46.00
905.770	1.63	25.30	22.60	31.95	36.28	9.72	46.00

Note:

1. All Readings below 1GHz are Quasi-Peak, above are performed with peak and/or average measurements as necessary.
- 2 " * ", means this data is the worst emission level.
3. Emission Level = Reading Level + Probe Factor + Cable Loss – PreAMP.

Product	BT-DH		
Test Item	Radiated Emission		
Test Mode	Mode 1: Transmit		
Date of Test	2005/03/03	Test Site	No.1 OATS

Channel 39

Frequency MHz	Cable Loss dB	Probe Factor dB/m	PreAMP dB	Reading Level dBuV	Emission Level dBuV/m	Margin dB	Limit dBuV/m
------------------	---------------------	-------------------------	--------------	--------------------------	-----------------------------	--------------	-----------------

=====

Vertical

Quasi-Peak

92.360	0.42	18.63	22.60	36.49	32.94	10.56	43.50
190.740	0.57	14.30	22.60	36.82	29.09	14.41	43.50
496.990	1.02	19.92	22.60	33.47	31.81	14.19	46.00
630.010	1.22	21.15	22.60	37.70	37.47	8.53	46.00
* 760.270	1.41	21.63	22.60	37.69	38.13	7.87	46.00
904.390	1.63	23.68	22.60	31.94	34.65	11.35	46.00

Note:

1. All Readings below 1GHz are Quasi-Peak, above are performed with peak and/or average measurements as necessary.
- 2 " * ", means this data is the worst emission level.
3. Emission Level = Reading Level + Probe Factor + Cable Loss – PreAMP.

Product	BT-DH		
Test Item	Radiated Emission		
Test Mode	Mode 1: Transmit		
Date of Test	2005/03/03	Test Site	No.1 OATS

Channel 78

Frequency MHz	Cable Loss dB	Probe Factor dB/m	PreAMP dB	Reading Level dBuV	Emission Level dBuV/m	Margin dB	Limit dBuV/m
------------------	---------------------	-------------------------	--------------	--------------------------	-----------------------------	--------------	-----------------

=====

Horizontal

Quasi-Peak

496.990	1.02	20.87	22.60	37.77	37.06	8.94	46.00
562.110	1.12	22.18	22.60	39.25	39.95	6.05	46.00
* 628.630	1.22	23.50	22.60	42.10	44.22	1.78	46.00
696.530	1.32	23.97	22.60	33.34	36.03	9.97	46.00
760.270	1.41	24.38	22.60	36.23	39.42	6.58	46.00
904.390	1.63	25.29	22.60	32.71	37.03	8.97	46.00

Note:

1. All Readings below 1GHz are Quasi-Peak, above are performed with peak and/or average measurements as necessary.
- 2 " * ", means this data is the worst emission level.
3. Emission Level = Reading Level + Probe Factor + Cable Loss – PreAMP.

Product	BT-DH		
Test Item	Radiated Emission		
Test Mode	Mode 1: Transmit		
Date of Test	2005/03/03	Test Site	No.1 OATS

Channel 78

Frequency MHz	Cable Loss dB	Probe Factor dB/m	PreAMP dB	Reading Level dBuV	Emission Level dBuV/m	Margin dB	Limit dBuV/m
=====							

Vertical

Quasi-Peak

93.740	0.42	19.10	22.60	34.86	31.79	11.71	43.50
230.930	0.63	14.00	22.60	37.15	29.18	16.82	46.00
496.990	1.02	19.92	22.60	33.07	31.41	14.59	46.00
630.010	1.22	21.15	22.60	37.50	37.27	8.73	46.00
* 760.270	1.41	21.63	22.60	37.09	37.53	8.47	46.00
905.770	1.63	23.64	22.60	31.81	34.48	11.52	46.00

Note:

1. All Readings below 1GHz are Quasi-Peak, above are performed with peak and/or average measurements as necessary.
- 2 " * ", means this data is the worst emission level.
3. Emission Level = Reading Level + Probe Factor + Cable Loss – PreAMP.

5. Band Edge

5.1. Test Equipment

The following test equipment are used during the test:

RF Conducted Measurement:				
Item	Equipment	Manufacturer	Model No. / Serial No.	Last Cal.
1	Spectrum Analyzer	R & S	FSP / 100561	Mar., 2005
2	No.1 OATS			Sep., 2004
RF Radiated Measurement:				
Item	Equipment	Manufacturer	Model No. / Serial No.	Last Cal.
1	X Spectrum Analyzer	R & S	FSP40 / 100005	Aug., 2004
2	X Pre-Amplifier	HP	8449B / 3008A01123	Feb., 2005
3	Loop Antenna	R & S	HFH2-Z2 / 833799/004	Sep., 2004
4	BiconiLog Antenna	Schwarzbeck	VULB 9166 / 1061	Sep., 2004
5	Bilog Antenna	Chase	CBL6112B / 2455	Sep., 2004
6	X Horn Antenna	Schwarzbeck	BBHA 9120D / BBHA9120D312	Sep., 2004
7	No.1 OATS			Sep., 2004

- Note: 1. All equipments that need to calibrate are with calibration period of 1 year.
 2. Mark "X" test instruments are used to measure the final test results.

5.2. Test Setup

RF Conducted Measurement:

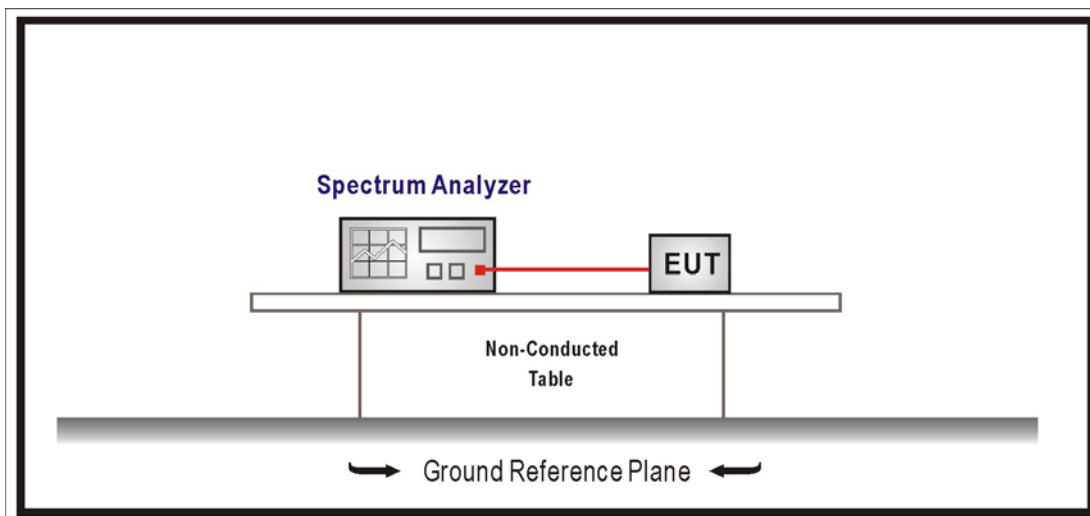

RF Radiated Measurement:

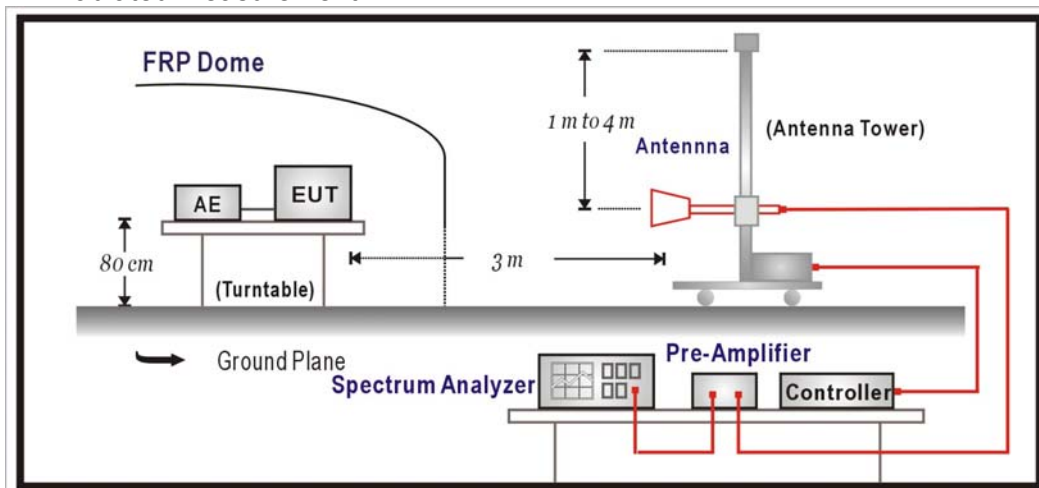

5.3. Limits

In any 100 kHz bandwidth outside the frequency band in which the spread spectrum intentional radiator is operating, the radio frequency power that is produced by the intentional radiator shall be at least 20 dB below that in the 100 kHz bandwidth within the band that contains the highest level of the desired power, based on either an RF conducted or a radiated measurement. Attenuation below the general limits specified in Section 15.209(a) is not required. In addition, radiated emissions which fall in the restricted bands, as defined in Section 15.205(a), must also comply with the radiated emission limits specified in Section 15.209(a) (see Section 15.205(c)).

5.4. Test Procedure

The EUT and its simulators are placed on a turn table which is 0.8 meter above ground. The turn table can rotate 360 degrees to determine the position of the maximum emission level. The EUT was positioned such that the distance from antenna to the EUT was 3 meters.

The antenna can move up and down between 1 meter and 4 meters to find out the maximum emission level.

Both horizontal and vertical polarization of the antenna are set on measurement. In order to find the maximum emission, all of the interface cables must be manipulated according to ANSI C63.4:2003 on radiated measurement.

The bandwidth below 1GHz setting on the field strength meter is 120 kHz, above 1GHz are 1 MHz.

5.5. Test Specification

According to FCC Part 15 Subpart C Paragraph 15.247: 2003

5.6. Test Result

Product	BT-DH		
Test Item	Band Edge		
Test Mode	Mode 1: Transmit		
Date of Test	2005/03/03	Test Site	No.1 OATS

RF Radiated Measurement: (Peak Detector)

Channel No.	Frequency (MHz)	Reading Level (dBuV)	Probe Factor (dB/m)	Cable Loss (dB)	PreAMP (dB)	Emission Level (dBuV/m)	Limit (dBuV/m)	Result
00(Horizontal)	2400.000	26.07	27.27	2.86	0.00	56.20	74	Pass
00(Vertical)	2400.000	33.09	27.27	2.86	0.00	63.22	74	Pass

Horizontal

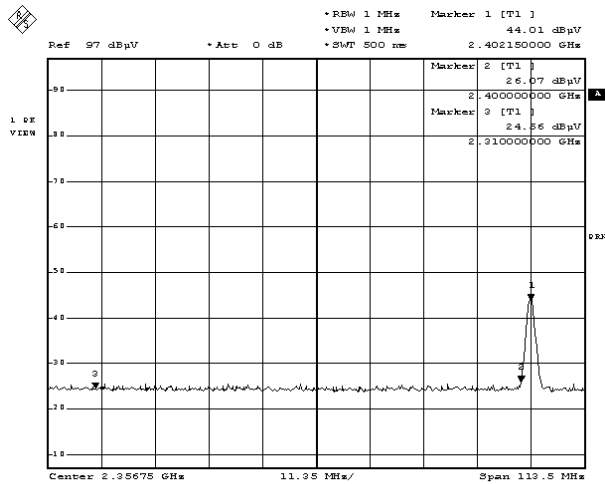

Date: 16.FEB.2005 22:46:51

Vertical

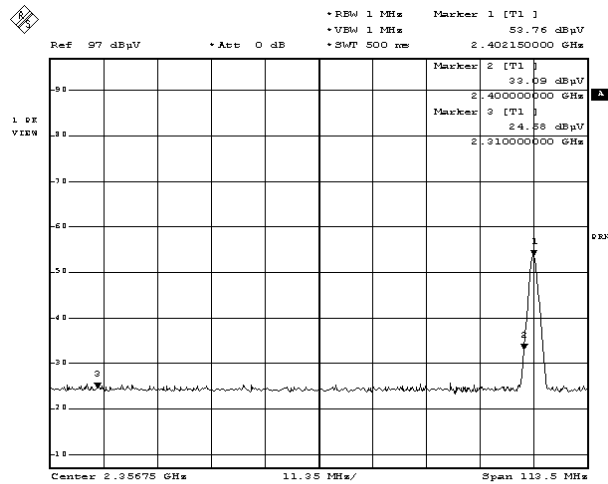

Date: 16.FEB.2005 22:51:42

Product	BT-DH		
Test Item	Band Edge		
Test Mode	Mode 1: Transmit		
Date of Test	2005/03/03	Test Site	No.1 OATS

RF Radiated Measurement: (Average Detector)

Channel No.	Frequency (MHz)	Reading Level (dBuV)	Probe Factor (dB/m)	Cable Loss (dB)	PreAMP (dB)	Emission Level (dBuV/m)	Limit (dBuV/m)	Result
00(Horizontal)	2400.000	15.05	27.27	2.86	0.00	45.18	54	Pass
00(Vertical)	2400.000	18.39	27.27	2.86	0.00	48.52	54	Pass

Horizontal

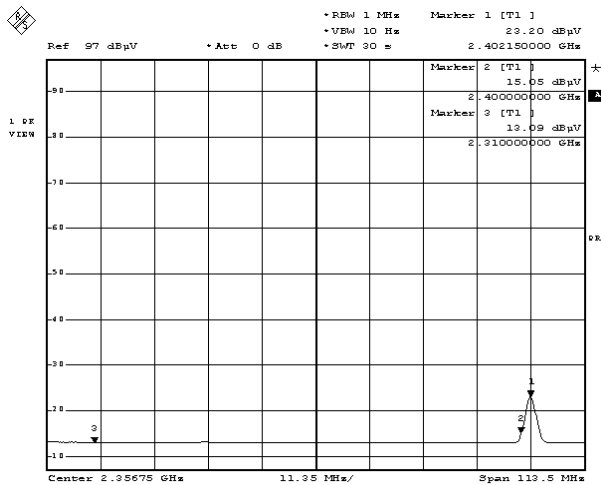

Date: 16.FEB.2005 22:48:24

Vertical

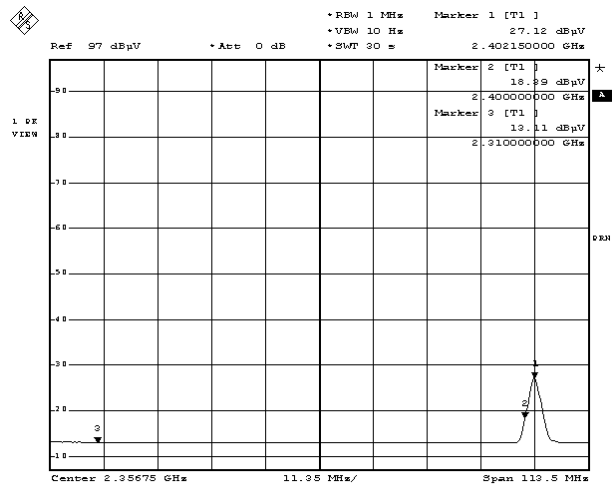

Date: 16.FEB.2005 22:58:06

Note: The average measurement was not performed when the peak measured data under the limit of average detection. If the readings given are average, peak measurement should also be supplied.

Product	BT-DH		
Test Item	Band Edge		
Test Mode	Mode 1: Transmit		
Date of Test	2005/03/03	Test Site	No.1 OATS

RF Radiated Measurement: (Peak Detector)

Channel No.	Frequency (MHz)	Reading Level (dBuV)	Probe Factor (dB/m)	Cable Loss (dB)	PreAMP (dB)	Emission Level (dBuV/m)	Limit (dBuV/m)	Result
78(Horizontal)	2483.500	24.70	27.58	2.91	0.00	55.19	74	Pass
78(Vertical)	2483.500	26.04	27.58	2.91	0.00	56.53	74	Pass

Horizontal

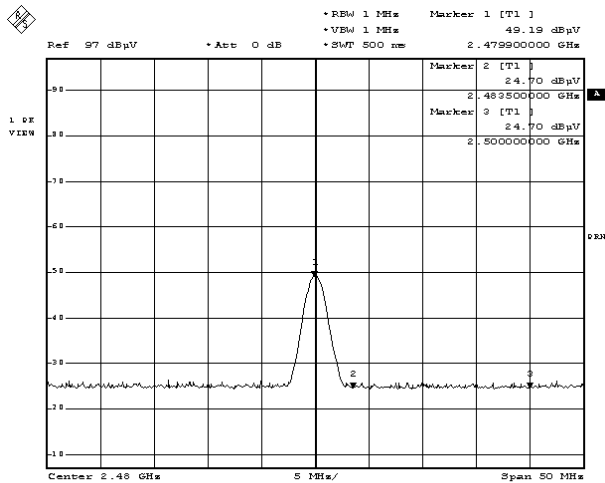

Vertical

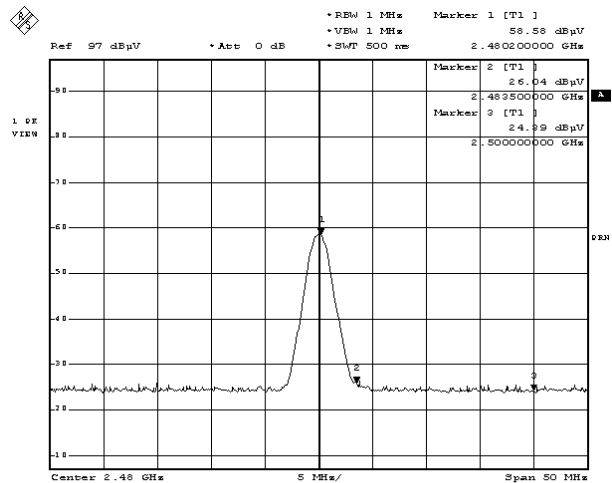

Note: The average measurement was not performed when the peak measured data under the limit of average detection. If the readings given are average, peak measurement should also be supplied.

Product	BT-DH		
Test Item	Band Edge		
Test Mode	Mode 1: Transmit		
Date of Test	2005/03/03	Test Site	No.1 OATS

RF Radiated Measurement: (Average Detector)

Channel No.	Frequency (MHz)	Reading Level (dBuV)	Probe Factor (dB/m)	Cable Loss (dB)	PreAMP (dB)	Emission Level (dBuV/m)	Limit (dBuV/m)	Result
78(Horizontal)	2483.500	13.75	27.58	2.91	0.00	44.24	54	Pass
78(Vertical)	2483.500	14.75	27.58	2.91	0.00	45.24	54	Pass

Horizontal

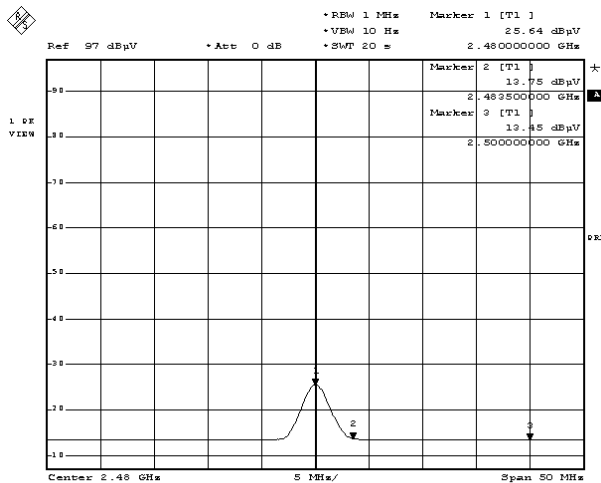

Date: 17.FEB.2005 09:10:13

Vertical

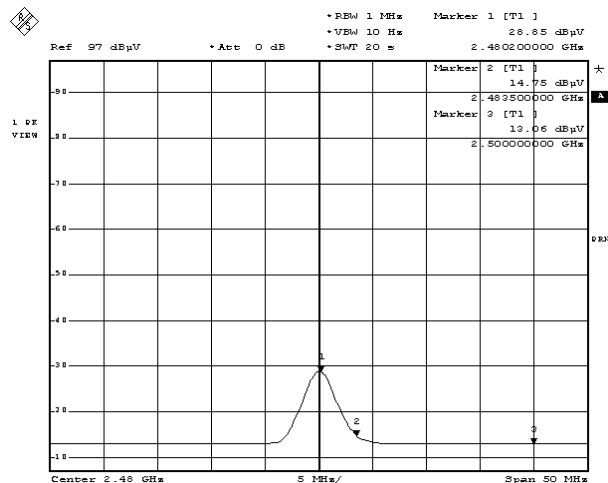

Date: 16.FEB.2005 22:58:17

Note: The average measurement was not performed when the peak measured data under the limit of average detection. If the readings given are average, peak measurement should also be supplied.

6. Channel of Number

6.1. Test Equipment

The following test equipment are used during the test:

Item	Equipment	Manufacturer	Model No. / Serial No.	Last Cal.
1	Spectrum Analyzer	R & S	FSP / 100561	Mar., 2005
2	No.1 OATS			Sep., 2004

Note: 1. All equipments that need to calibrate are with calibration period of 1 year.

6.2. Test Setup

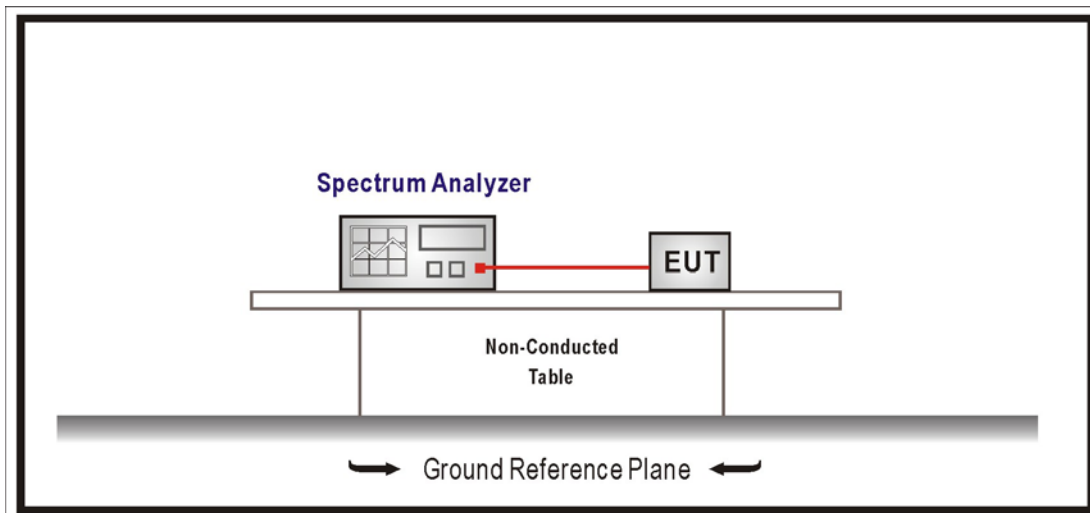

6.3. Limits

For frequency hopping systems operating in the 902-928 MHz band: if the 20 dB bandwidth of the hopping channel is less than 250 kHz, the system shall use at least 50 hopping frequencies and the average time of occupancy on any frequency shall not be greater than 0.4 seconds within a 20 second period; if the 20 dB bandwidth of the hopping channel is 250 kHz or greater, the system shall use at least 25 hopping frequencies and the average time of occupancy on any frequency shall not be greater than 0.4 seconds within a 10 second period. The maximum allowed 20 dB bandwidth of the hopping channel is 500 kHz.

For frequency hopping systems operating in the 2400-2483.5 MHz bands, which use fewer than 75 hopping frequencies, may employ intelligent hopping techniques to avoid interference to other transmissions. Frequency hopping systems may avoid or suppress transmissions on a particular hopping frequency provided that a minimum of 15 non-overlapping channels are used.

For frequency hopping systems operating in the 5725-5850 MHz band shall use at least 75 hopping frequencies.

6.4. Test Specification

According to FCC Part 15 Subpart C Paragraph 15.247: 2003

6.5. Test Result

Product	BT-DH		
Test Item	Channel of Number		
Test Mode	Mode 1: Transmit		
Date of Test	2005/03/03	Test Site	No.1 OATS

Frequency Range (MHz)	Measure Level (Hopping Channel)	Limit (Hopping Channel)	Result
2402 ~ 2480	79	>75	Pass

2402-2420MHz

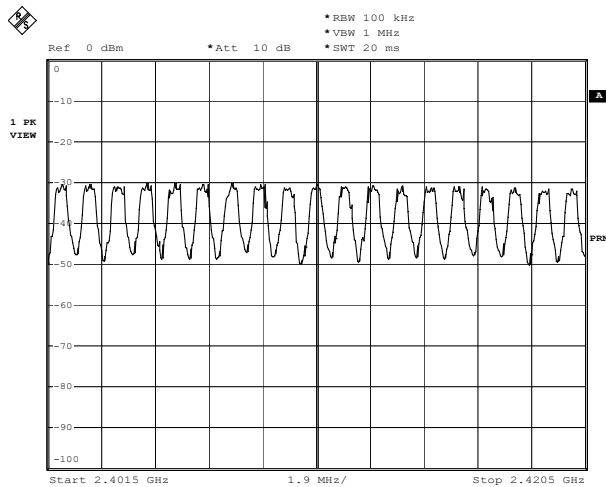

Date: 15.FEB.2005 13:42:26

2421-2440MHz

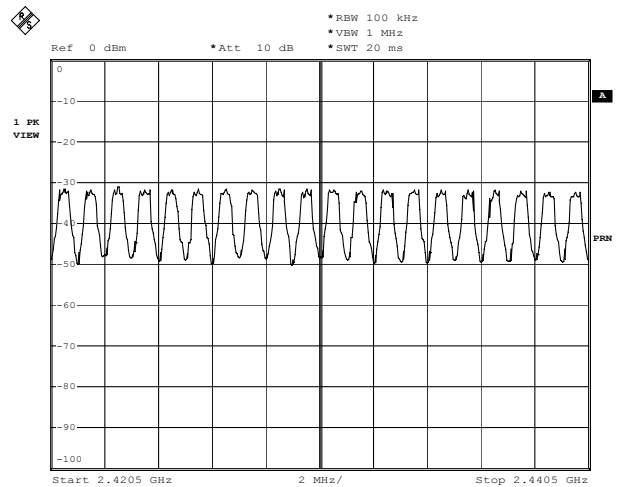

Date: 15.FEB.2005 13:50:51

2440-2461MHz

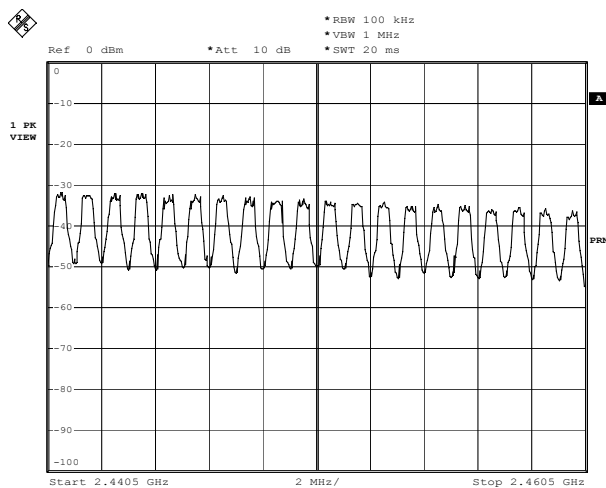

Date: 15.FEB.2005 14:09:48

2461-2480MHz

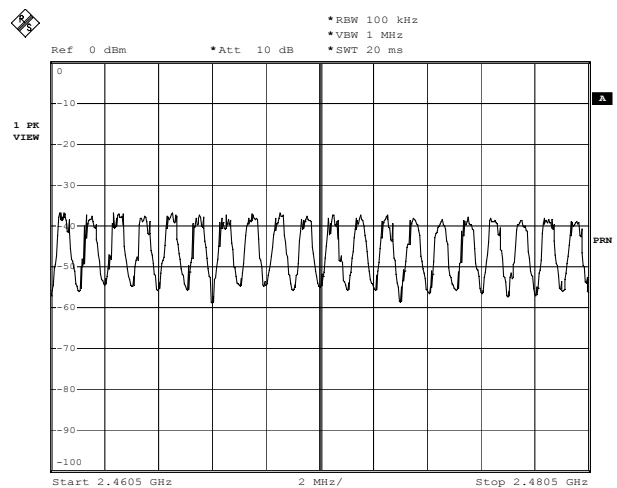

Date: 15.FEB.2005 14:13:21

7. Channel Separation

7.1. Test Equipment

The following test equipment are used during the test:

Item	Equipment	Manufacturer	Model No. / Serial No.	Last Cal.
1	Spectrum Analyzer	R & S	FSP / 100561	Mar., 2005
2	No.1 OATS			Sep., 2004

Note: 1. All equipments that need to calibrate are with calibration period of 1 year.

7.2. Test Setup

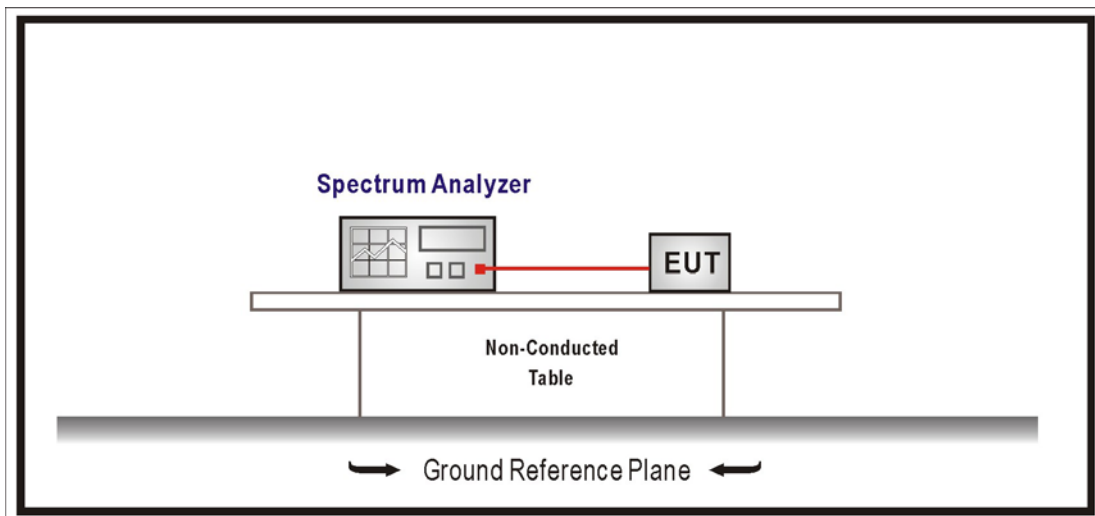

7.3. Limits

For frequency hopping systems shall have hopping channel carrier frequencies separated by a minimum of 25 kHz or the 20 dB bandwidth of the hopping channel, whichever is greater.

7.4. Test Specification

According to FCC Part 15 Subpart C Paragraph 15.247: 2003

7.5. Test Result

Product	BT-DH		
Test Item	Channel Separation		
Test Mode	Mode 1: Transmit		
Date of Test	2005/03/03	Test Site	No.1 OATS

Channel No.	Frequency (MHz)	Measure Level (kHz)	Limit (kHz)	Result
00	2402	1000	>25	Pass
39	2441	1000	>25	Pass
78	2480	1000	>25	Pass

Channel 00

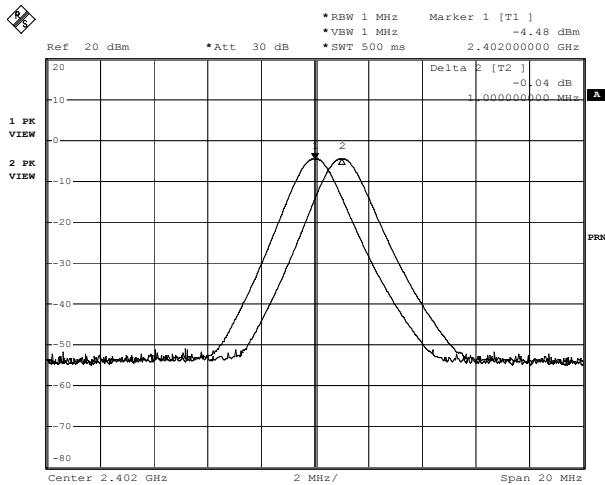

Date: 14.FEB.2005 15:10:42

Channel 39

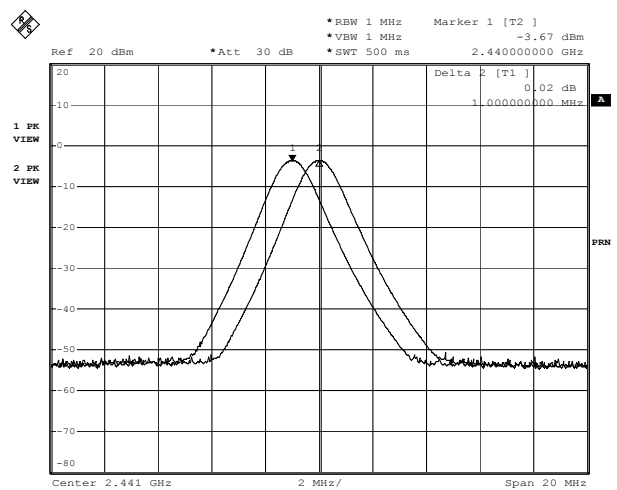

Date: 14.FEB.2005 15:13:10

Channel 78

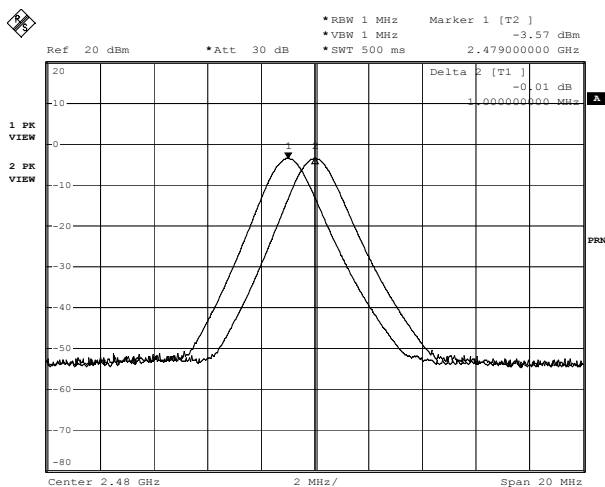

Date: 14.FEB.2005 15:08:47

8. Occupied Bandwidth

8.1. Test Equipment

The following test equipment are used during the test:

Item	Equipment	Manufacturer	Model No. / Serial No.	Last Cal.
1	Spectrum Analyzer	R & S	FSP / 100561	Mar., 2005
2	No.1 OATS			Sep., 2004

Note: 1. All equipments that need to calibrate are with calibration period of 1 year.

8.2. Test Setup

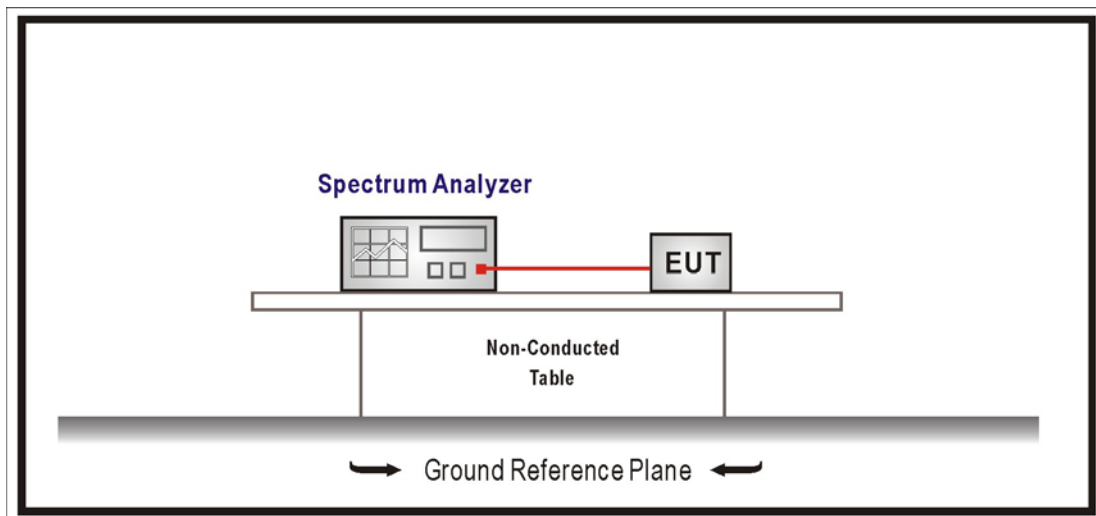

8.3. Limits

For frequency hopping systems operating in the 902-928 MHz band: if the 20 dB bandwidth of the hopping channel is less than 250 kHz, the system shall use at least 50 hopping frequencies and the average time of occupancy on any frequency shall not be greater than 0.4 seconds within a 20 second period; if the 20 dB bandwidth of the hopping channel is 250 kHz or greater, the system shall use at least 25 hopping frequencies and the average time of occupancy on any frequency shall not be greater than 0.4 seconds within a 10 second period. The maximum allowed 20 dB bandwidth of the hopping channel is 500 kHz.

For frequency hopping systems operating in the 5725-5850 MHz bands. The maximum 20 dB bandwidth of the hopping channel is 1 MHz.

For frequency hopping systems shall have hopping channel carrier frequencies separated by a minimum of 25 kHz or the 20 dB bandwidth of the hopping channel, whichever is greater.

8.4. Test Specification

According to FCC Part 15 Subpart C Paragraph 15.247: 2003

8.5. Test Result

Product	BT-DH		
Test Item	Occupied Bandwidth		
Test Mode	Mode 1: Transmit		
Date of Test	2005/03/03	Test Site	No.1 OATS

Channel No.	Frequency (MHz)	Measure Level (MHz)
00	2402	0.951904
39	2441	0.951904
78	2480	0.951904

Channel 00

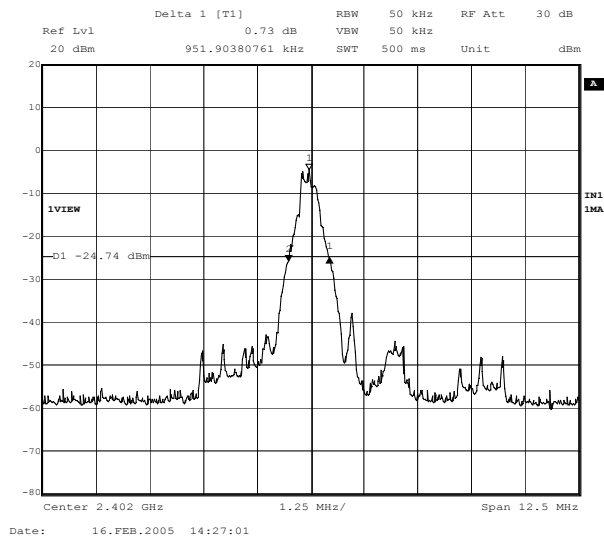

Channel 39

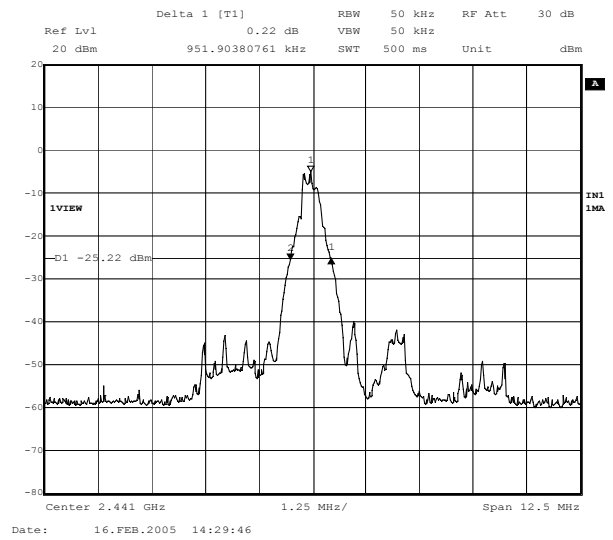

Channel 78

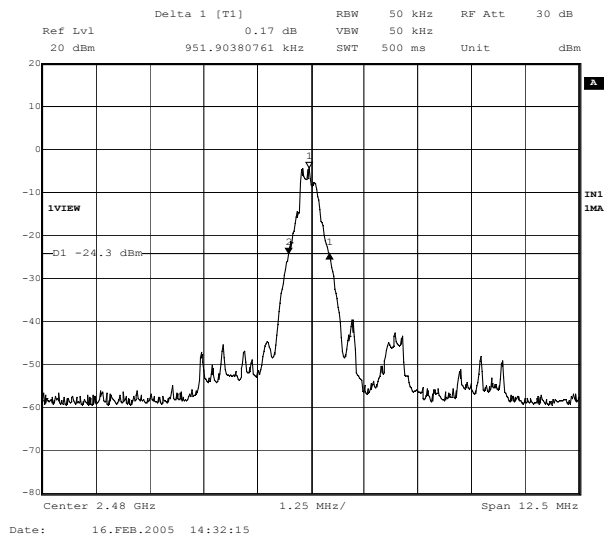

9. Dwell Time

9.1. Test Equipment

The following test equipment are used during the test:

Item	Equipment	Manufacturer	Model No. / Serial No.	Last Cal.
1	Spectrum Analyzer	R & S	FSP / 100561	Mar., 2005
2	No.1 OATS			Sep., 2004

Note: 1. All equipments that need to calibrate are with calibration period of 1 year.

9.2. Test Setup

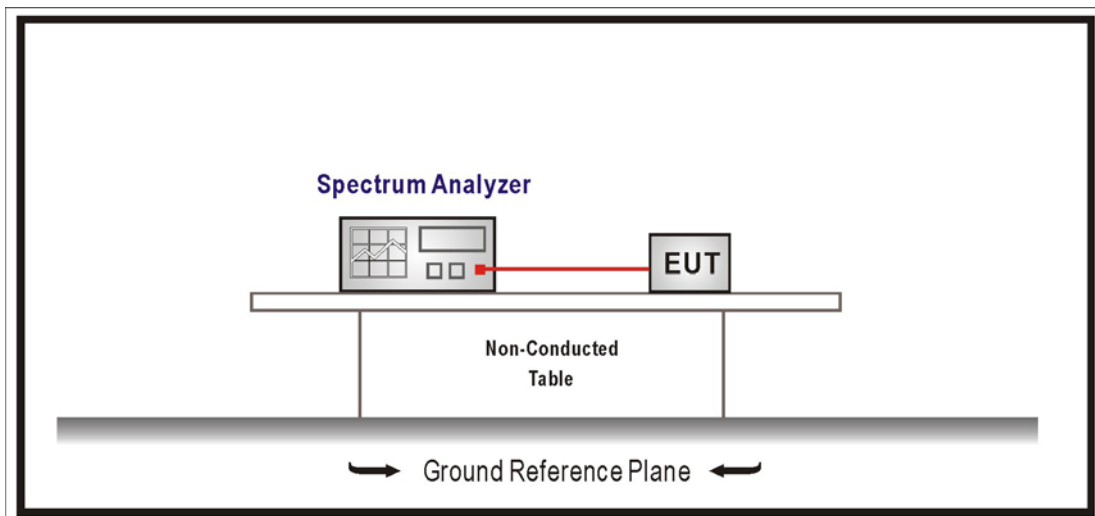

9.3. Limits

For frequency hopping systems operating in the 902-928 MHz band: if the 20 dB bandwidth of the hopping channel is less than 250 kHz, the system shall use at least 50 hopping frequencies and the average time of occupancy on any frequency shall not be greater than 0.4 seconds within a 20 second period; if the 20 dB bandwidth of the hopping channel is 250 kHz or greater, the system shall use at least 25 hopping frequencies and the average time of occupancy on any frequency shall not be greater than 0.4 seconds within a 10 second period. For frequency hopping systems operating in the 2400-2483.5 MHz bands. The average time of occupancy on any channel shall not be greater than 0.4 seconds within a period of 0.4 seconds multiplied by the number of hopping channels employed.

For frequency hopping systems operating in the 5725-5850 MHz bands. The average time of occupancy on any frequency shall not be greater than 0.4 seconds within a 30 second period.

9.4. Test Specification

According to FCC Part 15 Subpart C Paragraph 15.247: 2003

9.5. Test Result

Product	BT-DH		
Test Item	Dwell Time		
Test Mode	Mode 1: Transmit		
Date of Test	2005/03/03	Test Site	No.1 OATS

Channel No.	Frequency (MHz)	Measure Level (sec)	Limit (sec)	Result
00	2402.00	Period=0.4 (sec) * 79 (number of channel)=31.6 (sec) Hop rate=16 / 20 (ms)=800 / sec Time slot length=552 (µs)=0.000552 (sec) Dwell Time=0.000552 * 800 / 79 * 31.6=0.177 (sec)	<0.4	Pass

Hop rate

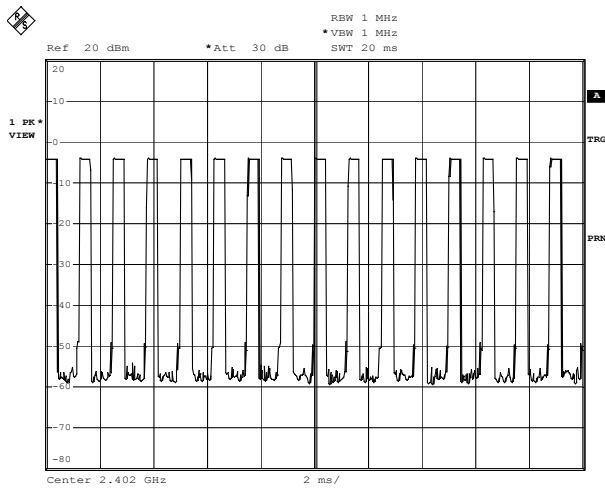

Date: 15.FEB.2005 17:17:47

Time slot length

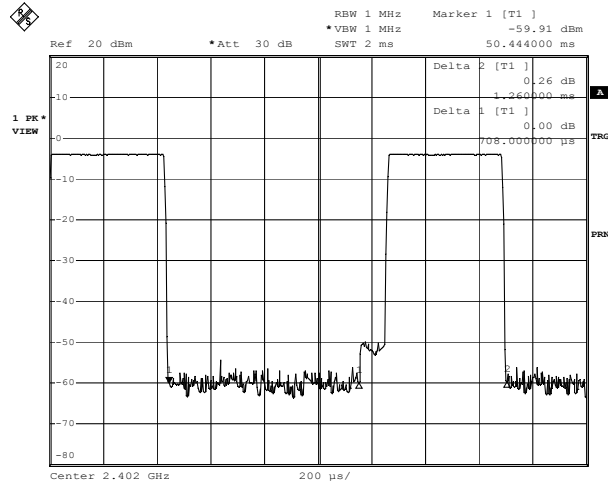

Date: 15.FEB.2005 17:46:58

Note: Dwell time = time slot length * hop rate / number of hopping channels * period

Product	BT-DH		
Test Item	Dwell Time		
Test Mode	Mode 1: Transmit		
Date of Test	2005/03/03	Test Site	No.1 OATS

Channel No.	Frequency (MHz)	Measure Level (sec)	Limit (sec)	Result
39	2441.00	Period = 0.4 (sec) * 79 (number of channel) = 31.6 (sec) Hop rate = 16 / 20 (ms) = 800 / sec Time slot length = 560 (µs) = 0.000560 (sec) Dwell Time = 0.000560 * 800 / 79 * 31.6 = 0.179 (sec)	<0.4	Pass

Hop rate

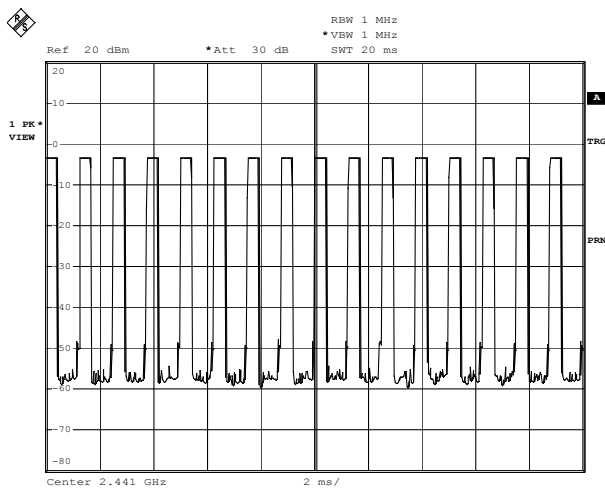

Date: 15.FEB.2005 17:16:53

Time slot length

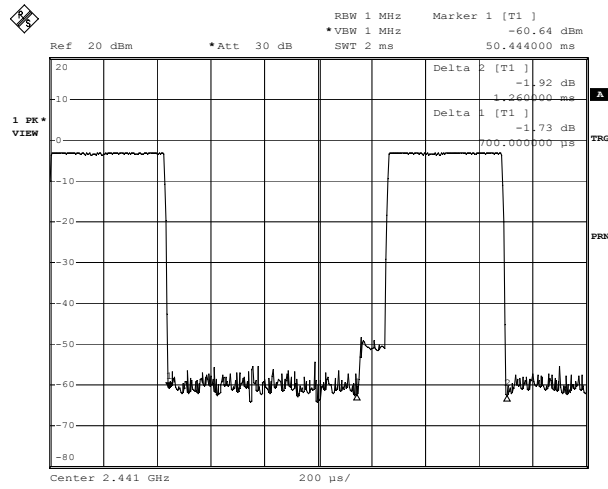

Date: 15.FEB.2005 17:48:25

Note: Dwell time = time slot length * hop rate / number of hopping channels * period

Product	BT-DH		
Test Item	Dwell Time		
Test Mode	Mode 1: Transmit		
Date of Test	2005/03/03	Test Site	No.1 OATS

Channel No.	Frequency (MHz)	Measure Level (sec)	Limit (sec)	Result
78	2480.00	Period = 0.4 (sec) * 79 (number of channel) = 31.6 (sec) Hop rate = 16 / 20 (ms) = 800 / sec Time slot length = 564 (µs) = 0.000564 (sec) Dwell Time = 0.000564 * 800 / 79 * 31.6 = 0.180 (sec)	<0.4	Pass

Hop rate

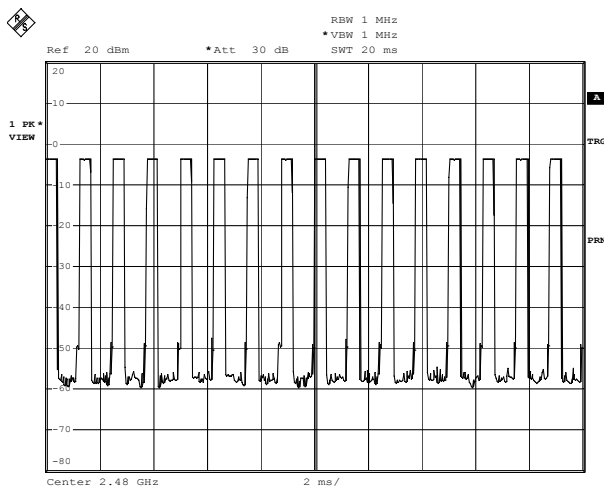

Date: 15.FEB.2005 17:15:10

Time slot length

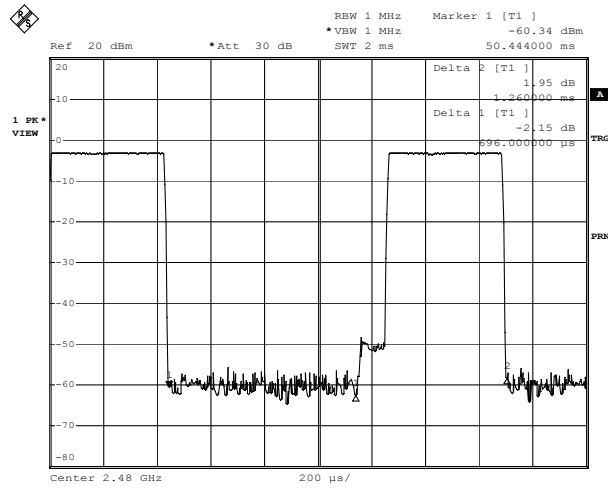

Date: 15.FEB.2005 17:49:36

Note: Dwell time = time slot length * hop rate / number of hopping channels * period