



FCC TEST REPORT

REPORT NO.: RF981111A04

MODEL NO.: STU-300

RECEIVED: Nov. 11, 2009

TESTED: Nov. 16 ~ 27, 2009

ISSUED: Nov. 30, 2009

APPLICANT: Wacom Co., Ltd.

ADDRESS: 2-510-1 Toyonodai, Otone-cho
Kitasaitama-gun, Saitama, 349-1148, Japan

ISSUED BY: Bureau Veritas Consumer Products Services
(H.K.) Ltd., Taoyuan Branch

LAB ADDRESS: No. 47, 14th Ling, Chia Pau Tsuen, Lin Kou
Hsiang, Taipei Hsien 244, Taiwan

This test report consists of 24 pages in total. It may be duplicated completely for legal use with the approval of the applicant. It should not be reproduced except in full, without the written approval of our laboratory. The client should not use it to claim product endorsement by TAF, or any government agencies. The test results in the report only apply to the tested sample.



Table of Contents

1	CERTIFICATION	3
2	SUMMARY OF TEST RESULTS	4
2.1	MEASUREMENT UNCERTAINTY	4
3	GENERAL INFORMATION	5
3.1	GENERAL DESCRIPTION OF EUT	5
3.2	DESCRIPTION OF TEST MODES	6
3.2.1	CONFIGURATION OF SYSTEM UNDER TEST	6
3.2.2	TEST MODE APPLICABILITY AND TESTED CHANNEL DETAIL	7
3.3	GENERAL DESCRIPTION OF APPLIED STANDARDS	8
3.4	DESCRIPTION OF SUPPORT UNITS	8
4	TEST PROCEDURE AND RESULT	9
4.1	CONDUCTED EMISSION MEASUREMENT	9
4.1.1	LIMITS OF CONDUCTED EMISSION MEASUREMENT	9
4.1.2	TEST INSTRUMENTS	10
4.1.3	TEST PROCEDURES	11
4.1.4	DEVIATION FROM TEST STANDARD	11
4.1.5	TEST SETUP	11
4.1.6	EUT OPERATING CONDITIONS	12
4.1.7	TEST RESULTS	13
4.2	RADIATED EMISSION MEASUREMENT	15
4.2.1	LIMITS OF RADIATED EMISSION MEASUREMENT	15
4.2.2	TEST INSTRUMENT	16
4.2.3	TEST PROCEDURE	17
4.2.4	DEVIATION FROM TEST STANDARD	17
4.2.5	TEST SETUP	18
4.2.6	EUT OPERATING CONDITION	18
4.2.7	TEST RESULT	19
4.2.8	TEST RESULTS (SPECTRUM BANDWIDTH)	21
5	PHOTOGRAPHS OF THE TEST CONFIGURATION	22
6	INFORMATION ON THE TESTING LABORATORIES	23
7	APPENDIX A – MODIFICATIONS RECORDERS FOR ENGINEERING CHANGES TO THE EUT BY THE LAB	24



1 CERTIFICATION

PRODUCT: LCD SIGNATURE TABLET
BRAND NAME: Wacom
MODEL NO.: STU-300
APPLICANT: Wacom Co., Ltd.
TESTED: Nov. 16 ~ 27, 2009
TEST SAMPLE: ENGINEERING SAMPLE
STANDARDS: FCC Part 15, Subpart C (Section 15.209),
ANSI C63.4 -2003

The above equipment has been tested by **Bureau Veritas Consumer Products Services (H.K.) Ltd., Taoyuan Branch**, and found compliance with the requirement of the above standards. The test record, data evaluation & Equipment Under Test (EUT) configurations represented herein are true and accurate accounts of the measurements of the sample's EMC characteristics under the conditions specified in this report.

PREPARED BY : *Kay Chen* , **DATE:** Nov. 30, 2009
(Kay Chen / Supervisor)

TECHNICAL ACCEPTANCE : *Jamison Chan* , **DATE:** Nov. 30, 2009
Responsible for RF (Jamison Chan / Supervisor)

APPROVED BY : *Ken Liu* , **DATE:** Nov. 30, 2009
(Ken Liu / Assistant Manager)

2 SUMMARY OF TEST RESULTS

The EUT has been tested according to the following specifications:

APPLIED STANDARD: FCC Part 15, Subpart C			
STANDARD PARAGRAPH	TEST TYPE	RESULT	REMARK
15.207	Conducted Emission Test	PASS	Meet the requirement of limit. Minimum passing margin is -16.36 dB at 0.173MHz.
15.209	Radiated Emission Test	PASS	Meet the requirement of limit. Minimum passing margin is -5.2 dB at 109.28MHz & 110.83MHz.

2.1 MEASUREMENT UNCERTAINTY

Where relevant, the following measurement uncertainty levels have been estimated for tests performed on the EUT as specified in CISPR 16-4-2:

This uncertainty represents an expanded uncertainty expressed at approximately the 95% confidence level using a coverage factor of $k=2$.

MEASUREMENT	UNCERTAINTY
Conducted emissions	2.44 dB
Radiated emissions	3.75 dB

3 GENERAL INFORMATION

3.1 GENERAL DESCRIPTION OF EUT

PRODUCT	LCD SIGNATURE TABLET
MODEL NO.	STU-300
FCC ID	HV4STU-300
POWER SUPPLY	5Vdc from PC
CARRIER FREQUENCY OF EACH CHANNEL	531.25 kHz 562.50 kHz 593.75 kHz
NUMBER OF CHANNEL	3
ANTENNA TYPE	Loop antenna
ANTENNA CONNECTOR	N/A
DATA CABLE	Shielded USB cable (1.6m)
I/O PORTS	N/A
ASSOCIATED DEVICES	Refer to note 2 as below

NOTE:

1. The EUT is a LCD SIGNATURE TABLET, which is transceiver.
2. The EUT is the ideal tool to enhance user's presentations and documents. The pen (Brand: Wacom, Model: UP-610-88A-1) will be sold together with the EUT.
3. For more detailed features description, please refer to the manufacturer's specifications or User's Manual.

3.2 DESCRIPTION OF TEST MODES

3 channels was provided to this EUT

Channel	Frequency (kHz)
1	531.25
2	562.5
3	593.75

3.2.1 CONFIGURATION OF SYSTEM UNDER TEST

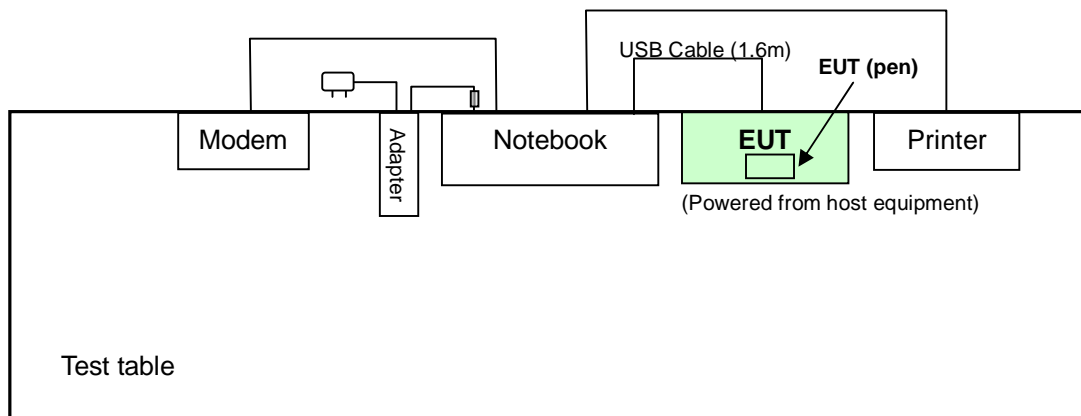

3.2.2 TEST MODE APPLICABILITY AND TESTED CHANNEL DETAIL

EUT CONFIGURE MODE	Applicable to		Description
	PLC	RE<1G	
-	√	√	-

Where PLC: Power Line Conducted Emission RE<1G RE: Radiated Emission below 1GHz

POWER LINE CONDUCTED EMISSION TEST:

Following channel(s) was (were) selected for the final test as listed below.

AVAILABLE CHANNEL	TESTED CHANNEL
1 ~ 3	2

RADIATED EMISSION TEST (BELOW 1 GHZ):

Following channel(s) was (were) selected for the final test as listed below.

AVAILABLE CHANNEL	TESTED CHANNEL
1 ~ 3	2

TEST CONDITION:

APPLICABLE TO	ENVIRONMENTAL CONDITIONS	INPUT POWER (SYSTEM)	TESTED BY
PLC	20deg. C, 85% RH, 1017hPa	120Vac, 60Hz	Nick Chen
RE<1G	20deg. C, 76% RH, 1015hPa	120Vac, 60Hz	Nick Chen

3.3 GENERAL DESCRIPTION OF APPLIED STANDARDS

The EUT is a RF product. According to the specifications of the manufacturer, it must comply with the requirements of the following standards:

FCC Part 15, Subpart C. (15.209)
ANSI C63.4 -2003

All test items have been performed and recorded as per the above standards.

NOTE: The product has been verified to comply with the requirements of FCC Part 15, Subpart B, Class B (DoC). The test report has been issued separately.

3.4 DESCRIPTION OF SUPPORT UNITS

The EUT has been tested as an independent unit together with other necessary accessories or support units. The following support units or accessories were used to form a representative test configuration during the tests.

NO.	PRODUCT	BRAND	MODEL NO.	SERIAL NO.	FCC ID
1	NOTEBOOK COMPUTER	DELL	PP05L	20375526736	FCC DoC Approved
2	PRINTER	EPSON	LQ-300+	DCGY017054	FCC DoC Approved
3	MODEM	ACEEX	1414	980020520	IFAXDM1414

NO.	SIGNAL CABLE DESCRIPTION OF THE ABOVE SUPPORT UNITS
1	N/A
2	1.8m braid shielded wire, terminated with DB25 and Centronics connector via metallic frame, w/o core
3	1.2m braid shielded wire, terminated with DB25 and DB9 connector via metallic frame, w/o core.

NOTE: All power cords of the above support units are non shielded (1.8m).

4 TEST PROCEDURE AND RESULT

4.1 CONDUCTED EMISSION MEASUREMENT

4.1.1 LIMITS OF CONDUCTED EMISSION MEASUREMENT

FREQUENCY OF EMISSION (MHz)	CONDUCTED LIMIT (dB μ V)	
	Quasi-peak	Average
0.15-0.5	66 to 56	56 to 46
0.5-5	56	46
5-30	60	50

- NOTE:**
1. The lower limit shall apply at the transition frequencies.
 2. The limit decreases in line with the logarithm of the frequency in the range of 0.15 to 0.50 MHz.
 3. All emanations from a class A/B digital device or system, including any network of conductors and apparatus connected thereto, shall not exceed the level of field strengths specified above.



4.1.2 TEST INSTRUMENTS

DESCRIPTION & MANUFACTURER	MODEL NO.	SERIAL NO.	CALIBRATED DATE	CALIBRATED UNTIL
ROHDE & SCHWARZ Test Receiver	ESCS 30	838251/021	Mar. 05, 2009	Mar. 04, 2010
ROHDE & SCHWARZ Artificial Mains Network (for EUT)	ESH3-Z5	100218	Nov. 24, 2009	Nov. 23, 2010
LISN With Adapter (for EUT)	AD10	C10Ada-001	Nov. 24, 2009	Nov. 23, 2010
ROHDE & SCHWARZ Artificial Mains Network (for peripherals)	ESH3-Z5	100219	Nov. 23, 2009	Nov. 22, 2010
Software	ADT_Cond_V7.3.7	NA	NA	NA
Software	ADT_ISN_V7.3.7	NA	NA	NA
RF cable (JYEBAO)	5D-FB	Cable-C10.01	Feb. 26, 2009	Feb. 25, 2010
SUHNER Terminator (For ROHDE & SCHWARZ LISN)	65BNC-5001	E1-010773	Feb. 27, 2009	Feb. 26, 2010

- NOTE:**
1. The calibration interval of the above test instruments is 12 months and the calibrations are traceable to NML/ROC and NIST/USA.
 2. The test was performed in Shielded Room No. 10.
 3. The VCCI Site Registration No. C-1852.

4.1.3 TEST PROCEDURES

- a. The EUT was placed 0.4 meters from the conducting wall of the shielded room with EUT being connected to the power mains through a line impedance stabilization network (LISN). Other support units were connected to the power mains through another LISN. The two LISNs provide 50 ohm/ 50uH of coupling impedance for the measuring instrument.
- b. Both lines of the power mains connected to the EUT were checked for maximum conducted interference.
- c. The frequency range from 150kHz to 30MHz was searched. Emission levels under (Limit - 20dB) were not recorded.

4.1.4 DEVIATION FROM TEST STANDARD

No deviation

4.1.5 TEST SETUP

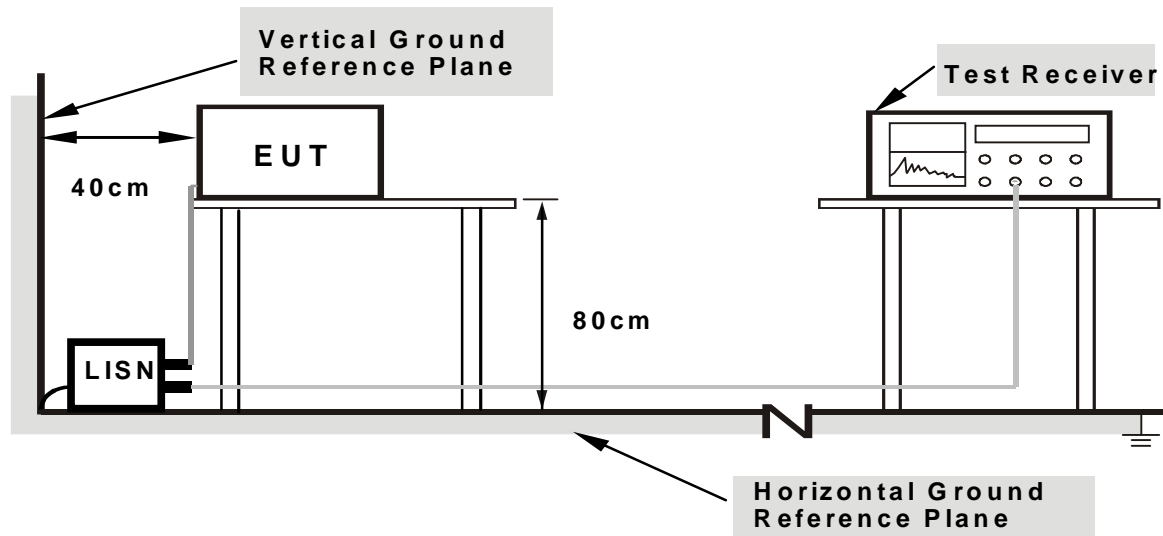

- Note:**
1. Support units were connected to second LISN.
 2. Both of LISNs (AMN) are 80cm from EUT and at least 80cm from other units and other metal planes support units.

For the actual test configuration, please refer to the related item – Photographs of the Test Configuration.

4.1.6 EUT OPERATING CONDITIONS

- a. Connected the LCD SIGNATURE TABLET (EUT) to Notebook via USB cable.
- b. Turned on the power of all equipment.
- c. Notebook ran a test program to enable all functions.
- d. Set the EUT under transmission/receiving condition continuously at specific channel frequency.
- e. Notebook read and wrote messages from HDD.
- f. Notebook sent messages to printer and the printer printed them out.
- g. Notebook sent messages to modem.
- h. Steps e-h were repeated.

4.1.7 TEST RESULTS

PHASE	Line 1	6dB BANDWIDTH	9 kHz
-------	--------	---------------	-------

No	Freq. [MHz]	Corr. Factor (dB)	Reading Value		Emission Level		Limit		Margin	
			[dB (uV)]		[dB (uV)]		[dB (uV)]		(dB)	
	Q.P.	AV.	Q.P.	AV.	Q.P.	AV.	Q.P.	AV.	Q.P.	AV.
1	0.170	0.12	46.85	-	46.97	-	64.98	54.98	-18.01	-
2	0.252	0.16	39.70	-	39.86	-	61.71	51.71	-21.85	-
3	0.341	0.20	33.18	-	33.38	-	59.17	49.17	-25.79	-
4	1.893	0.36	24.53	-	24.89	-	56.00	46.00	-31.11	-
5	9.379	0.69	24.83	-	25.52	-	60.00	50.00	-34.48	-
6	24.000	1.84	24.54	-	26.38	-	60.00	50.00	-33.62	-

- REMARKS:**
1. Q.P. and AV. are abbreviations of quasi-peak and average individually.
 2. "-": The Quasi-peak reading value also meets average limit and measurement with the average detector is unnecessary.
 3. The emission levels of other frequencies were very low against the limit.
 4. Margin value = Emission level - Limit value
 5. Correction factor = Insertion loss + Cable loss
 6. Emission Level = Correction Factor + Reading Value.

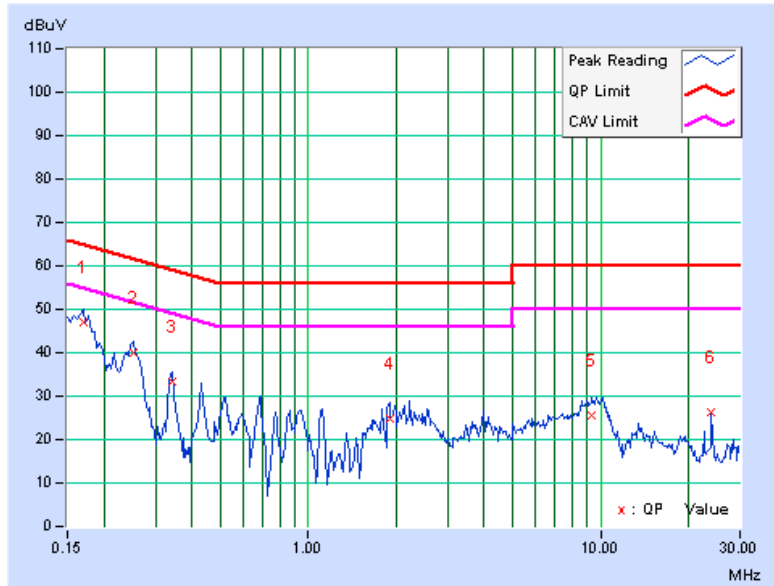

PHASE	Line 2	6dB BANDWIDTH	9 kHz
-------	--------	---------------	-------

No	Freq. [MHz]	Corr. Factor (dB)	Reading Value		Emission Level		Limit		Margin	
			[dB (uV)]		[dB (uV)]		[dB (uV)]		(dB)	
			Q.P.	AV.	Q.P.	AV.	Q.P.	AV.	Q.P.	AV.
1	0.173	0.13	48.32	-	48.45	-	64.81	54.81	-16.36	-
2	0.259	0.16	39.19	-	39.35	-	61.45	51.45	-22.10	-
3	0.339	0.20	32.15	-	32.35	-	59.23	49.23	-26.88	-
4	1.783	0.43	26.59	-	27.02	-	56.00	46.00	-28.98	-
5	9.483	0.63	24.24	-	24.87	-	60.00	50.00	-35.13	-
6	24.000	1.65	24.44	-	26.09	-	60.00	50.00	-33.91	-

- REMARKS:**
1. Q.P. and AV. are abbreviations of quasi-peak and average individually.
 2. "-": The Quasi-peak reading value also meets average limit and measurement with the average detector is unnecessary.
 3. The emission levels of other frequencies were very low against the limit.
 4. Margin value = Emission level - Limit value
 5. Correction factor = Insertion loss + Cable loss
 6. Emission Level = Correction Factor + Reading Value.

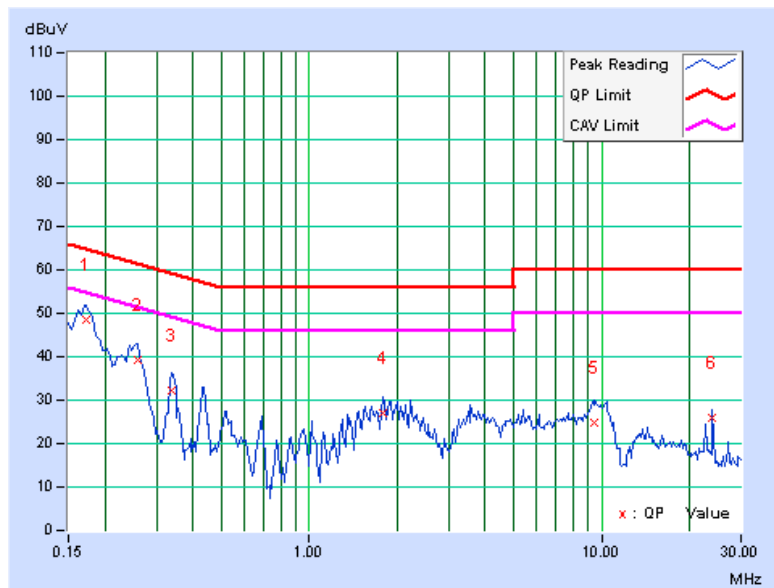

4.2 RADIATED EMISSION MEASUREMENT

4.2.1 LIMITS OF RADIATED EMISSION MEASUREMENT

FOR FREQUENCY BELOW 30MHz

FREQUENCY (MHz)	FIELD STRENGTH (dBuV/m)		MEASUREMENT DISTANCE (meters)
	uV/m	dBuV/m	
0.009 – 0.490	2400 / F (kHz)	48.52-13.80	300
0.490 – 1.705	24000 / F (kHz)	33.80-22.97	30
1.705 – 30.0	30	29.54	30

FOR FREQUENCY BETWEEN 30-1000MHz

FREQUENCY (MHz)	Class A (at 10m)		Class B (at 3m)	
	uV/m	dBuV/m	uV/m	dBuV/m
30-88	90	39.1	100	40.0
88-216	150	43.5	150	43.5
216-960	210	46.4	200	46.0
Above 960	300	49.5	500	54.0

FOR FREQUENCY ABOVE 1000MHz

FREQUENCY (MHz)	Class A (at 10m)		Class B (at 3m)	
	PEAK	AVERAGE	PEAK	AVERAGE
Above 1000	80.0	60.0	74.0	54.0

- Note: (1) The lower limit shall apply at the transition frequencies.
 (2) Emission level (dBuV/m) = 20 log Emission level (uV/m).
 (3) All emanation from a class A/B digital device or system, including any network of conductors and apparatus connected thereto, shall not exceed the level of fieldstrengths specified above.



4.2.2 TEST INSTRUMENT

DESCRIPTION & MANUFACTURER	MODEL NO.	SERIAL NO.	CALIBRATED DATE	CALIBRATED UNTIL
HP Preamplifier	8447D	2432A03504	May 04, 2009	May 03, 2010
HP Preamplifier	8449B	3008A01924	Aug. 31, 2009	Aug. 30, 2010
HP Preamplifier	8449B	3008A01292	Aug. 10, 2009	Aug. 09, 2010
ROHDE & SCHWARZ TEST RECEIVER	ESU26	100005	Jun. 06, 2009	Jun. 05, 2010
Schwarzbeck Antenna	VULB 9168	137	Apr. 29, 2009	Apr. 28, 2010
Schwarzbeck Antenna	VHBA 9123	480	Apr. 21, 2009	Apr. 20, 2010
ADT. Turn Table	TT100	0306	NA	NA
ADT. Tower	AT100	0306	NA	NA
Software	ADT_Radiated_V 7.6.15.9.2	NA	NA	NA
SUHNER RF cable	SF104-26.5	CABLE-CH6-17m -01	Aug. 20, 2009	Aug. 19, 2010
ROHDE & SCHWARZ Spectrum Analyzer	FSP 40	100036	Apr. 03, 2009	Apr. 02, 2010
Loop Antenna R & S	HFH2-Z2	100070	Jan. 14, 2008	Jan. 13, 2010

- NOTE:**
1. The calibration interval of the above test instruments is 12/24 months. And the calibrations are traceable to NML/ROC and NIST/USA.
 2. The horn antenna and HP preamplifier (model: 8449B) are used only for the measurement of emission frequency above 1GHz if tested.
 3. The test was performed in Chamber No. 6.
 4. The Industry Canada Reference No. IC 7450E-6.
 5. The FCC Site Registration No. is 447212.

4.2.3 TEST PROCEDURE

- a. The EUT was placed on the top of a rotating table 0.8 meters above the ground at a 3 meter semi-anechoic chamber. The table was rotated 360 degrees to determine the position of the highest radiation.
- b. The EUT was set 3 meters away from the interference-receiving antenna, which was mounted on the top of a variable-height antenna tower.
- c. The height of antenna is varied from one meter to four meters above the ground to determine the maximum value of the field strength. Both horizontal and vertical polarizations of the antenna are set to make the measurement.
- d. For each suspected emission, the EUT was arranged to its worst case and then the antenna was tuned to heights from 1 meter to 4 meters and the rotatable table was turned from 0 degrees to 360 degrees to find the maximum reading.
- e. The test-receiver system was set to Peak Detect Function and Specified Bandwidth with Maximum Hold Mode.
- f. If the emission level of the EUT in peak mode was lower than the limit specified, then testing could be stopped and the peak values of the EUT would be reported. Otherwise the emissions would be re-tested one by one using peak, quasi-peak method or average method as specified and then reported in data sheet.
- g. For measurement of frequency above 1000 MHz, the EUT was set 3 meters away from the interference antenna and the detect function was set to Peak or Average.

4.2.4 DEVIATION FROM TEST STANDARD

No deviation

4.2.5 TEST SETUP

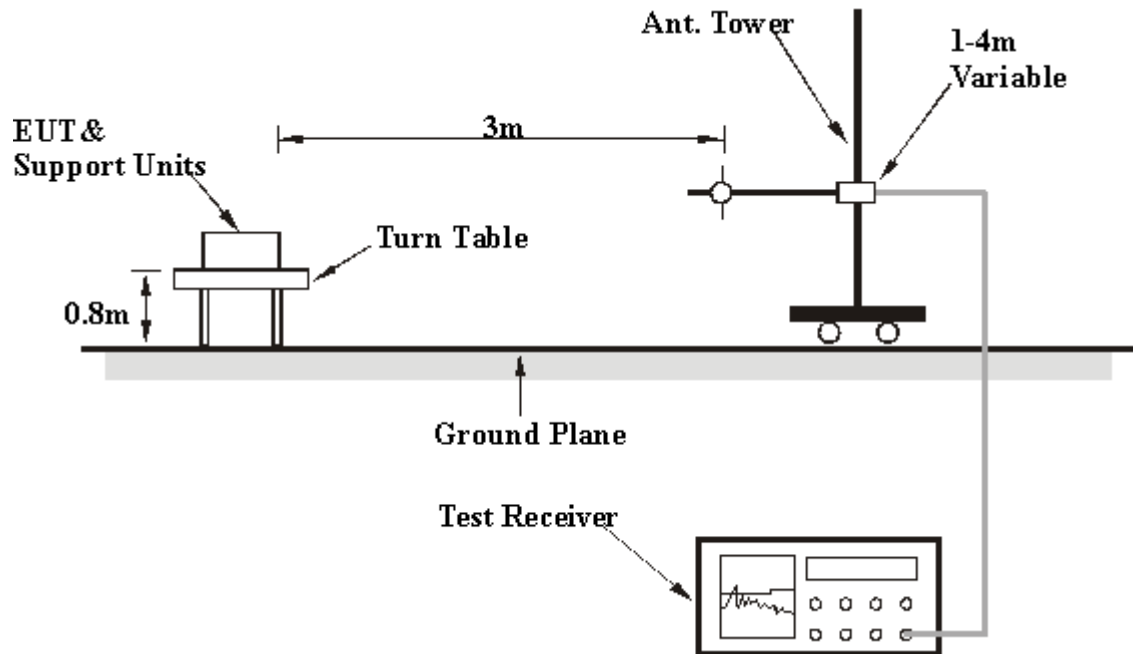

For the actual test configuration, please refer to the related item in this test report - Photographs of the Test Configuration.

4.2.6 EUT OPERATING CONDITION

Same as item 4.1.6.

4.2.7 TEST RESULT

CHANNEL	Channel 2	FREQUENCY RANGE	9 kHz ~ 30 MHz
INPUT POWER (SYSTEM)	120Vac, 60 Hz	DETECTOR FUNCTION	Quasi-Peak
ENVIRONMENTAL CONDITIONS	20deg. C, 76% RH, 1015hPa	TESTED BY	Nick Chen

ANTENNA POLARITY & TEST DISTANCE: AT 3 M								
No.	Freq. (MHz)	Emission Level (dBuV/m)	Limit (dBuV/m)	Margin (dB)	Antenna Height (m)	Table Angle (Degree)	Raw Value (dBuV)	Correction Factor (dB/m)
1	0.56	45.1 QP	72.6	-27.5	1.00	25	25.99	19.14
2	1.12	40.1 QP	66.6	-26.5	1.00	257	20.86	19.27
3	1.69	34.9 QP	63.1	-28.2	1.00	241	15.44	19.45
4	2.24	31.4 QP	69.5	-28.1	1.00	126	11.81	19.55
5	2.81	34.6 QP	69.5	-24.9	1.00	124	15.04	19.55
6	3.37	29.7 QP	69.5	-29.8	1.00	157	10.20	19.54
7	3.93	28.1 QP	69.5	-21.4	1.00	105	8.58	19.54

- REMARKS:**
1. Emission level(dBuV/m)=Raw Value(dBuV) + Correction Factor(dB/m)
 2. Correction Factor(dB/m) = Antenna Factor (dB/m) + Cable Factor (dB)
 3. The other emission levels were very low against the limit.
 4. Margin value = Emission level – Limit value.
 5. Above limits have been translated by the formula
 6. Loop antenna was used for all radiated emission below 30MHz.

The measured field strength was extrapolated to distance 30 meters, using the formula that the limit of field strength varies as the inverse distance square (40dB per decade of distance)

Example:

24000/562.5kHz	=42.7 uV/m	30m
	=32.6 dBuV/m	30m
	=32.6+20log(30/3)	3m
	=72.6 dBuV/m	

CHANNEL	Channel 2	FREQUENCY RANGE	30-1000MHz
INPUT POWER (SYSTEM)	120Vac, 60 Hz	DETECTOR FUNCTION	Quasi-Peak
ENVIRONMENTAL CONDITIONS	20deg. C, 76% RH, 1017hPa	TESTED BY	Nick Chen

ANTENNA POLARITY & TEST DISTANCE: HORIZONTAL AT 3 M

No.	Freq. (MHz)	Emission Level (dBuV/m)	Limit (dBuV/m)	Margin (dB)	Antenna Height (m)	Table Angle (Degree)	Raw Value (dBuV)	Correction Factor (dB/m)
1	110.83	38.3 QP	43.5	-5.2	1.05 H	112	28.10	10.23
2	280.27	33.9 QP	46.0	-12.1	1.32 H	223	19.48	14.46
3	295.82	33.5 QP	46.0	-12.5	1.37 H	184	18.31	15.23
4	679.78	35.4 QP	46.0	-10.6	1.23 H	328	10.93	24.50
5	696.88	34.7 QP	46.0	-11.3	1.18 H	295	9.98	24.76
6	731.07	33.2 QP	46.0	-12.8	1.27 H	256	7.78	25.42
7	867.87	35.6 QP	46.0	-10.4	1.02 H	208	7.93	27.63

ANTENNA POLARITY & TEST DISTANCE: VERTICAL AT 3 M

No.	Freq. (MHz)	Emission Level (dBuV/m)	Limit (dBuV/m)	Margin (dB)	Antenna Height (m)	Table Angle (Degree)	Raw Value (dBuV)	Correction Factor (dB/m)
1	109.28	38.3 QP	43.5	-5.2	1.09 V	178	28.22	10.04
2	132.60	35.3 QP	43.5	-8.2	1.13 V	130	22.60	12.73
3	678.22	30.0 QP	46.0	-16.0	1.08 V	262	5.57	24.47
4	732.63	34.2 QP	46.0	-11.8	1.32 V	187	8.75	25.45
5	864.76	36.2 QP	46.0	-9.8	1.21 V	199	8.61	27.59
6	917.61	31.6 QP	46.0	-14.4	1.32 V	256	3.35	28.23

- REMARKS:**
1. Emission level (dBuV/m) = Raw Value (dBuV) + Correction Factor (dB/m).
 2. Correction Factor (dB/m) = Antenna Factor (dB/m) + Cable Factor (dB).
 3. The other emission levels were very low against the limit.
 4. Margin value = Emission level – Limit value.



A D T

4.2.8 TEST RESULTS (SPECTRUM BANDWIDTH)

562.5kHz

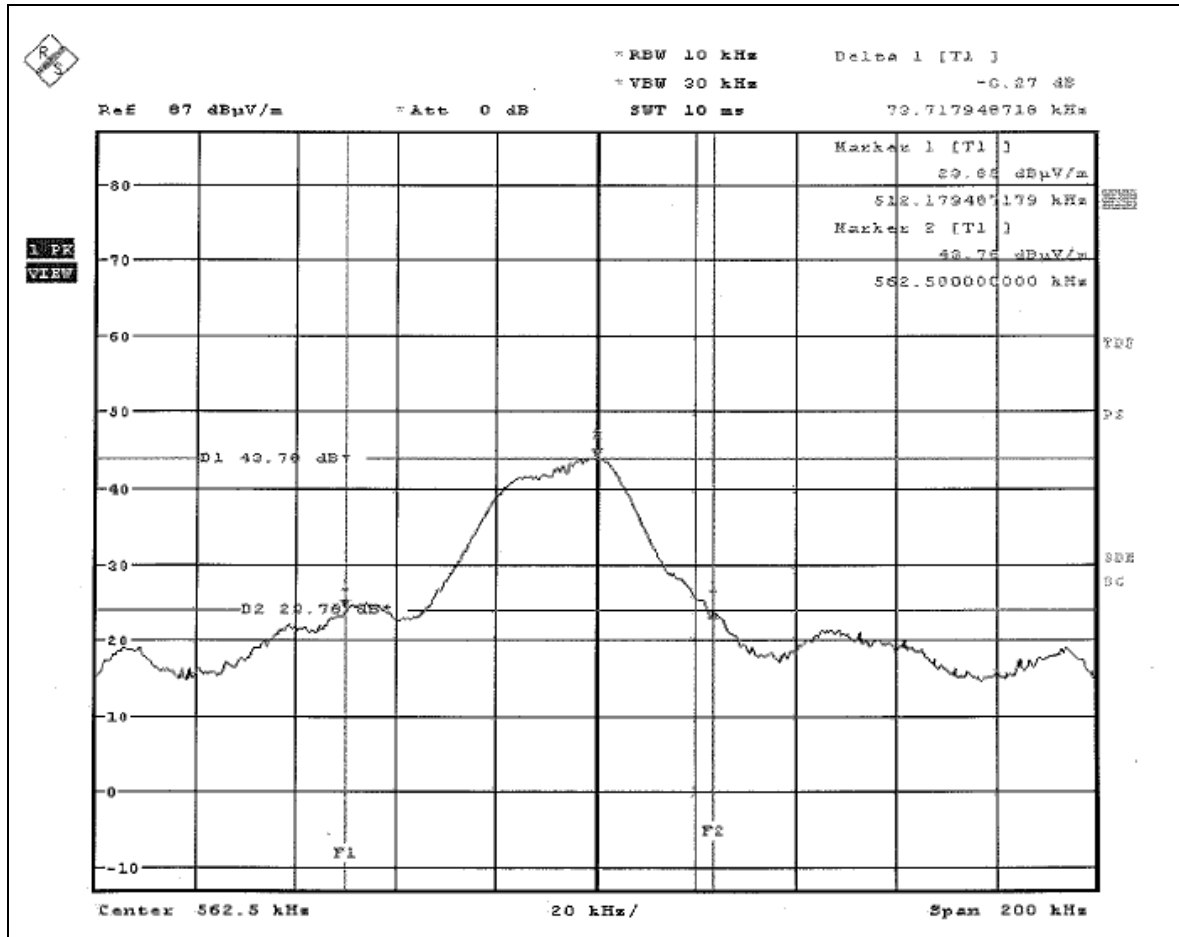



A D T

5 PHOTOGRAPHS OF THE TEST CONFIGURATION

Please refer to the attached file (Test Setup Photo).



6 INFORMATION ON THE TESTING LABORATORIES

We, Bureau Veritas Consumer Products Services (H.K.) Ltd., Taoyuan Branch, were founded in 1988 to provide our best service in EMC, Radio, Telecom and Safety consultation. Our laboratories are accredited and approved by the following approval agencies according to ISO/IEC 17025.

USA	FCC, NVLAP
Germany	TUV Rheinland
Japan	VCCI
Norway	NEMKO
Canada	INDUSTRY CANADA, CSA
R.O.C.	TAF, BSMI, NCC
Netherlands	Telefication
Singapore	GOST-ASIA(MOU)
Russia	CERTIS(MOU)

Copies of accreditation certificates of our laboratories obtained from approval agencies can be downloaded from our web site: www.adt.com.tw/index.5/phtml.
If you have any comments, please feel free to contact us at the following:

Linko EMC/RF Lab:
Tel: 886-2-26052180
Fax: 886-2-26051924

Hsin Chu EMC/RF Lab:
Tel: 886-3-5935343
Fax: 886-3-5935342

Hwa Ya EMC/RF/Safety Telecom Lab:
Tel: 886-3-3183232
Fax: 886-3-3185050

Web Site: www.adt.com.tw

The address and road map of all our labs can be found in our web site also.

7 APPENDIX A – MODIFICATIONS RECORDERS FOR ENGINEERING CHANGES TO THE EUT BY THE LAB

No any modifications are made to the EUT by the lab during the test.

---END---