



**Spectrum Research
& Testing Lab., Inc.**

No. 101-10, Ling 8,
Shan-Tong Li, Chung-Li
City, Taoyuan, Taiwan,
R.O.C.

TEST REPORT

Reference No.: A07010302
Report No.: FCCA07010302
FCC ID: HV4DTZ2000W
Page: 1 of 29
Date: Feb. 06, 2007

Product Name: LCD Tablet
Model No.: DTZ-2000X (X = 0-9, A-Z or blank)
Brand Name: WACOM Co., Ltd.
Applicant: Foxlink Image Technology CO., LTD.
11, Lane 596, Chien Hsing Road, Sec. 2, Hsinfeng,
Hsinchu, Taiwan
Date of Receipt: Jan. 03, 2007
Finished date of Test: Feb. 06, 2007
Applicable Standards: 47 CFR Part 15, Subpart C, Class B
ANSI C63.4:2003

We, **Spectrum Research & Testing Laboratory Inc.**, hereby certify that one sample of the above was tested in our laboratory with positive results according to the above-mentioned standards. The records in the report are an accurate account of the results. Details of the results are given in the subsequent pages of this report.

Tested By : Lily Yang , Date: Feb/06/2007
(Lily Yang)

Approved By : JH , Date: 2/06/2007
(Johnson Ho, Director)



Lab Code: 200099-0



Table of Contents

1.	DOCUMENT POLICY AND TEST STATEMENT	3
1.1	DOCUMENT POLICY	3
1.2	TEST STATEMENT	3
1.3	EUT MODIFICATION	3
2.	DESCRIPTION OF EUT AND TEST MODE	4
2.1	GENERAL DESCRIPTION OF EUT	4
2.2	DESCRIPTION OF EUT INTERNAL DEVICE	5
2.3	DESCRIPTION OF TEST MODE	5
2.4	DESCRIPTION OF SUPPORT UNIT	6
3.	DESCRIPTION OF APPLIED STANDARDS	7
4.	CONDUCTED EMISSION TEST	8
4.1	CONDUCTED EMISSION LIMIT	8
4.2	TEST EQUIPMENT	8
4.3	TEST SETUP	9
4.4	TEST PROCEDURE	9
4.5	EUT OPERATING CONDITION	9
4.6	TEST RESULT	10
5.	RADIATED EMISSION TEST	18
5.1	RADIATED EMISSION LIMIT	18
5.2	TEST EQUIPMENT	19
5.3	TEST SET-UP	20
5.4	TEST PROCEDURE	22
5.5	EUT OPERATING CONDITION	22
5.6	RADIATED EMISSION TEST RESULT	23
6.	PHOTOS OF TESTING	26
7.	TERMS OF ABBREVIATION	29



**Spectrum Research
& Testing Lab., Inc.**

No. 101-10, Ling 8,
Shan-Tong Li, Chung-Li
City, Taoyuan, Taiwan,
R.O.C.

TEST REPORT

Reference No.:A07010302
Report No.:FCCA07010302
FCC ID: HV4DTZ2000W
Page:3 of 29
Date: Feb. 06, 2007

1. DOCUMENT POLICY AND TEST STATEMENT

1.1 DOCUMENT POLICY

- The report shall not be reproduced except in full, without the written approval of SRT Lab, Inc.
- The report must not be used by the applicant to claim that the product is endorsed by NVLAP, TÜV, NEMKO and SRT.
- The NVLAP logo applies only to the applicable standards specified in this report.

1.2 TEST STATEMENT

- The test results in the report apply only to the unit tested by SRT Lab.
- There was no deviation from the requirements of test standards during the test.
- AC power source, 120 Vac/60 Hz, was used during the test.

1.3 EUT MODIFICATION

- No modification in SRT Lab.



2. DESCRIPTION OF EUT AND TEST MODE

2.1 GENERAL DESCRIPTION OF EUT

PRODUCT	LCD TABLET
BRAND NAME	WACOM Co., Ltd.
MODEL NO.	DTZ-2000X (X = 0-9, A-Z or blank)
POWER SUPPLY	DC from an external power adapter
CABLE	Shielded AC Power cable 1.8m. Shielded USB cable 1.2m with one ferrite core Shielded DVI cable 0.5m. Shielded VGA cable 0.3m.
FREQUENCY	667KHz
NUMBER OF CHANNEL	1
ANTENNA TYPE	Loop Antenna
TYPE	Proto Type

NOTE:

The EUT has two kinds of adapters on market.

Adapter	Brand	Model No.	Specification
1	LI SHIN	0218B1270	I/P: 100-240V~60/50Hz 2.0A O/P: DC12V / 5.83A DC cable 1.2m shielded with a ferrite core. AC cable 1.8m shielded.
2	LI SHIN	0219B1270	I/P: 100-240V~60/50Hz 1.5A O/P: DC12V / 5.83A DC cable 1.2m shielded with a ferrite core. AC cable 1.8m shielded.
3	LIEN	LE-0316B120072	I/P: 100-240V~60/50Hz 1.5A O/P: DC12V / 6.0A DC cable 1.2m shielded with a ferrite core. AC cable 1.8m shielded.
4	HJC	HASU12FB	I/P: 100-240V~60/50Hz 1.8A O/P: DC12V / 5.0A DC cable 1.2m shielded with a ferrite core. AC cable 1.8m shielded.

For more detailed information, please refer to the EUT's specification or user's manual provided by manufacturer.



2.2 DESCRIPTION OF EUT INTERNAL DEVICE

DEVICE	BRAND / MAKER	MODEL #	FCC ID/DOC	REMARK
Grip Pen	N/A	ZP-501E-00A	DOC	

NOTE:

1. The highest clock is 14.314MHz.
2. Frequency range to be measured.
Radiated emission is 9 MHz to 1 GHz.

2.3 DESCRIPTION OF TEST MODE

The EUT has four kinds of adapters on market.

Adapter	Brand	Model No.	Specification
1	LI SHIN	0218B1270	I/P: 100-240V~60/50Hz 2.0A O/P: DC12V / 5.83A DC cable 1.2m shielded with a ferrite core. AC cable 1.8m shielded.
2	LI SHIN	0219B1270	I/P: 100-240V~60/50Hz 1.5A O/P: DC12V / 5.83A DC cable 1.2m shielded with a ferrite core. AC cable 1.8m shielded.
3	LIEN	LE-0316B120072	I/P: 100-240V~60/50Hz 1.5A O/P: DC12V / 6.0A DC cable 1.2m shielded with a ferrite core. AC cable 1.8m shielded.
4	HJC	HASU12FB	I/P: 100-240V~60/50Hz 1.8A O/P: DC12V / 5.0A DC cable 1.2m shielded with a ferrite core. AC cable 1.8m shielded.

The EUT was pre-tested and final tested under the following mode:

Mode		Pretest resolution	Final test
Mode 1	Adapter 1(DVI)	800*600 60Hz	1680*1050 60Hz
		1024*768 60Hz	
		1680*1050 60Hz	
Mode 2	Adapter 1(VGA)	800*600 60Hz	1680*1050 60Hz
		1024*768 60Hz	
		1680*1050 60Hz	
Mode 3	Adapter 2(DVI)	800*600 60Hz	1680*1050 60Hz
		1024*768 60Hz	
		1680*1050 60Hz	
Mode 4	Adapter 2(VGA)	800*600 60Hz	1680*1050 60Hz
		1024*768 60Hz	
		1680*1050 60Hz	
Mode 5	Adapter 3(DVI)	800*600 60Hz	1680*1050 60Hz
		1024*768 60Hz	
		1680*1050 60Hz	



Spectrum Research & Testing Lab., Inc.

No. 101-10, Ling 8,
Shan-Tong Li, Chung-Li
City, Taoyuan, Taiwan,
R.O.C.

TEST REPORT

Reference No.:A07010302
Report No.:FCCA07010302
FCC ID: HV4DTZ2000W
Page:6 of 29
Date: Feb. 06, 2007

Mode 6	Adapter 3(VGA)	800*600 60Hz	1680*1050 60Hz
		1024*768 60Hz	
		1680*1050 60Hz	
Mode 7	Adapter 4(DVI)	800*600 60Hz	1680*1050 60Hz
		1024*768 60Hz	
		1680*1050 60Hz	
Mode 8	Adapter 4(VGA)	800*600 60Hz	1680*1050 60Hz
		1024*768 60Hz	
		1680*1050 60Hz	

NOTE :

For RADIATED EMISSION TEST :We only selected a worse one that had pre-scan for four adapters to test.

2.4 DESCRIPTION OF SUPPORT UNIT

The EUT was configured by the requirement of ANSI C63.4:2003 and CISPR22:2003. All interface ports were connected to the appropriate support units via specific cables. The support units and cables are listed below.

NO	DEVICE	BRAND	MODEL #	FCC ID /DOC	CABLE
1	Monitor	Samsung	PG17IS	DOC	1.8m unshielded power cord 1.5m shielded data cable
2	PC	ACER	VT7600G	DOC	N/A
3	Keyboard	ACER	6312/TA4C/6	DOC	1.5m shielded data cable
4	Mouse	Logitech	M-SAW90A	DOC	1.7m shielded data cable
5	Modem	ACEEX	DM-1414	DOC	1.8m unshielded DC power cord 1.5m shielded data cable
6	Printer	EPSON	STYLUS C20SX	N/A	1.5m unshielded power cord 1.5m shielded data cable

NOTE : For the actual test configuration, please refer to the photos of testing.



**Spectrum Research
& Testing Lab., Inc.**

No. 101-10, Ling 8,
Shan-Tong Li, Chung-Li
City, Taoyuan, Taiwan,
R.O.C.

TEST REPORT

Reference No.:A07010302

Report No.:FCCA07010302

FCC ID: HV4DTZ2000W

Page:7 of 29

Date: Feb. 06, 2007

3. DESCRIPTION OF APPLIED STANDARDS

The EUT is a kind of ITE and according to the specifications provided by the applicant, it must comply with the requirements of the following standards:

47 CFR Part 15, Subpart C

ANSI C63.4:2003

All tests have been performed and recorded as per the above standards.



4. CONDUCTED EMISSION TEST

4.1 CONDUCTED EMISSION LIMIT

FREQUENCY (MHz)	Class A (dB μ V)		Class B (dB μ V)	
	Quasi-peak	Average	Quasi-peak	Average
0.15 - 0.5	79	66	66 - 56	56 - 46
0.5 - 5.0	73	60	56	46
5.0 - 30.0	73	60	60	50

NOTE:

1. The lower limit shall apply at the transition frequencies.
2. The limit decreases in line with the logarithm of the frequency in the range of 0.15 to 0.50 MHz.

4.2 TEST EQUIPMENT

The following test equipment was used for the test:

EQUIPMENT/ FACILITIES	SPECIFICATIONS	MANUFACTURER	MODEL#/ SERIAL#	DUE DATE OF CAL. & CAL. CENTER
EMI TEST RECEIVER	9 kHz TO 30 MHz	ROHDE & SCHWARZ	ESHS30/ 826003/008	AUG. 2007 ETC
LISN (for Peripheral)	50 μ H, 50 ohm	FCC	FCC-LISN-50-25-2/ 01017	NOV. 2007 ETC
LISN (for Peripheral)	50 μ H, 50 ohm	FCC	FCC-LISN-50-25-2/ 01018	NOV. 2007 ETC
50 ohm TERMINATOR	50 ohm	HP	11593A/ 2	OCT. 2007 ETC
COAXIAL CABLE	5m	SUNCITY	CABLE 05/ # 5-5M	JUL. 2007 SRT
ISOLATION TRANSFORMER	N/A	APC	AFC-11015/ F102040016	N/A
FILTER	2 LINE, 30A	FIL.COIL	FC-943/ 771	N/A
GROUND PLANE	2.3M (H) x 2.4M (W)	SRT	N/A	N/A
GROUND PLANE	2.4M (H) x 2.4M (W)	SRT	N/A	N/A

NOTE: The calibration interval of the above test equipment is one year and the calibrations are traceable to NML/ROC and NIST/USA.



4.3 TEST SETUP

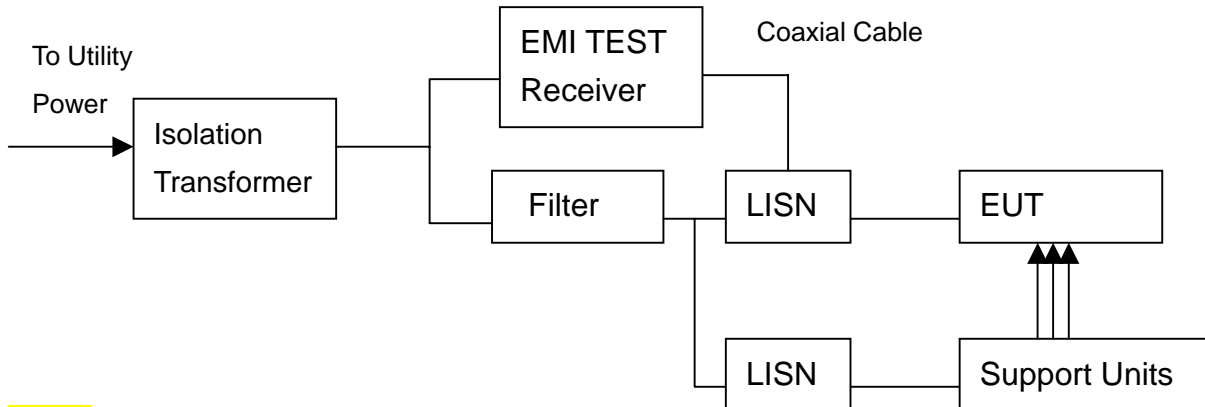

NOTE:

1. The EUT was put on a wooden table with 0.8m heights above ground plane, and 0.4m away from reference ground plane (> 2mx2m).
2. For the actual test configuration, please refer to the photos of testing.

4.4 TEST PROCEDURE

The EUT was tested according to the requirement of ANSI C63.4:2003 and CISPR22:2003. The frequency spectrum from 0.15 MHz to 30 MHz was investigated. The LISN used was 50 ohm/50 μ H as specified. All readings were quasi-peak and average values with 10 kHz resolution bandwidth of the test receiver. The EUT system was operated in all typical methods by users. Both lines of the power mains of EUT were measured and the cables connected to EUT and support units were moved to find the maximum emission levels for each frequency. First, find the margin or higher points at least 6 points by software, then use manual to find the maximum data. The procedure is referred on the test procedure of SRT LAB.

4.5 EUT OPERATING CONDITION

1. Under Windows XP ran "EMI TEST" , "EMCTEST" and "WINFCC" programs.
2. Notebook sent "H" pattern or accessed the following peripherals directly or via EUT:

- Panel
- RS232
- Keyboard
- Printer
- FDD
- HDD



4.6 TEST RESULT

Temperature:	24 °C	Humidity:	76 %RH
Ferquency Range:	0.15 – 30 MHz	Tested Mode 1:	Adapter 1(DVI) 1680*1050 60Hz
Receiver Detector:	Q.P. and AV.	Tested By:	Yvonne Chen
		Tested Date:	Jan. 15, 2007

Power Line Measured : Line

Freq. (MHz)	Correct. Factor (dB)	Reading Value (dB μ V)		Emission Level (dB μ V)		Limit (dB μ V)		Margin (dB)	
		Q.P.	AV.	Q.P.	AV.	Q.P.	AV.	Q.P.	AV.
0.150	0.30	44.52	21.36	44.82	21.66	66.00	56.00	-21.18	-34.34
0.156	0.30	43.54	22.46	43.84	22.76	65.66	55.66	-21.82	-32.90
2.586	0.17	33.40	28.43	33.57	28.60	56.00	46.00	-22.43	-17.40
2.635	0.17	33.30	22.54	33.47	22.71	56.00	46.00	-22.53	-23.29
6.695	0.22	34.74	19.74	34.96	19.96	60.00	50.00	-25.04	-30.04
7.142	0.22	34.68	19.74	34.90	19.96	60.00	50.00	-25.10	-30.04

Power Line Measured : Neutral

Freq. (MHz)	Correct. Factor (dB)	Reading Value (dB μ V)		Emission Level (dB μ V)		Limit (dB μ V)		Margin (dB)	
		Q.P.	AV.	Q.P.	AV.	Q.P.	AV.	Q.P.	AV.
0.156	0.30	43.76	23.14	44.06	23.44	65.66	55.66	-21.60	-32.22
0.159	0.30	42.92	25.78	43.22	26.08	65.50	55.50	-22.28	-29.42
2.814	0.18	36.48	20.95	36.66	21.13	56.00	46.00	-19.34	-24.87
2.992	0.18	36.86	17.94	37.04	18.12	56.00	46.00	-18.96	-27.88
6.756	0.22	35.74	20.50	35.96	20.72	60.00	50.00	-24.04	-29.28
6.868	0.22	35.76	20.55	35.98	20.77	60.00	50.00	-24.02	-29.23

NOTE :

1. Measurement uncertainty is +/-1.32dB
2. Emission level = Reading value + Correction factor
3. Correction Factor = Cable loss + Insertion loss of LISN
4. Margin value = Emission level - Limit
5. The emission of other frequencies were very low against the limit.
6. "-": The Quasi-peak reading value also meets average limit and measurement with the average detector is unnecessary.



Temperature:	24 °C	Humidity:	76 %RH
Ferquency Range:	0.15 – 30 MHz	Tested Mode 2:	Adapter 1(VGA) 1680*1050 60Hz
Receiver Detector:	Q.P. and AV.	Tested By:	Yvonne Chen
		Tested Date:	Jan. 15, 2007

Power Line Measured : Line

Freq. (MHz)	Correct. Factor (dB)	Reading Value (dBμV)		Emission Level (dBμV)		Limit (dBμV)		Margin (dB)	
		Q.P.	AV.	Q.P.	AV.	Q.P.	AV.	Q.P.	AV.
0.159	0.30	43.76	29.90	44.06	30.20	65.50	55.50	-21.44	-25.30
0.162	0.30	43.10	30.47	43.40	30.77	65.34	55.34	-21.94	-24.57
0.610	0.22	27.54	24.49	27.76	24.71	56.00	46.00	-28.24	-21.29
4.348	0.21	33.62	20.57	33.83	20.78	56.00	46.00	-22.17	-25.22
7.091	0.22	33.56	21.91	33.78	22.13	60.00	50.00	-26.22	-27.87
7.395	0.22	33.86	22.60	34.08	22.82	60.00	50.00	-25.92	-27.18

Power Line Measured : Neutral

Freq. (MHz)	Correct. Factor (dB)	Reading Value (dBμV)		Emission Level (dBμV)		Limit (dBμV)		Margin (dB)	
		Q.P.	AV.	Q.P.	AV.	Q.P.	AV.	Q.P.	AV.
0.150	0.30	44.74	20.30	45.04	20.60	66.00	56.00	-20.96	-35.40
0.153	0.30	44.22	20.87	44.52	21.17	65.82	55.82	-21.30	-34.65
2.586	0.17	35.12	22.02	35.29	22.19	56.00	46.00	-20.71	-23.81
3.121	0.18	35.76	23.24	35.94	23.42	56.00	46.00	-20.06	-22.58
6.989	0.22	36.28	21.39	36.50	21.61	60.00	50.00	-23.50	-28.39
7.192	0.22	36.88	25.70	37.10	25.92	60.00	50.00	-22.90	-24.08

NOTE :

1. Measurement uncertainty is +/-1.32dB
2. Emission level = Reading value + Correction factor
3. Correction Factor = Cable loss + Insertion loss of LISN
4. Margin value = Emission level - Limit
5. The emission of other frequencies were very low against the limit.
6. "-": The Quasi-peak reading value also meets average limit and measurement with the average detector is unnecessary.

**Spectrum Research & Testing Lab., Inc.**No. 101-10, Ling 8,
Shan-Tong Li, Chung-Li
City, Taoyuan, Taiwan,
R.O.C.**TEST REPORT**Reference No.:A07010302
Report No.:FCCA07010302
FCC ID: HV4DTZ2000W
Page:12 of 29
Date: Feb. 06, 2007

Temperature:	24 °C	Humidity:	76 %RH
Ferquency Range:	0.15 – 30 MHz	Tested Mode 3:	Adapter 2(DVI) 1680*1050 60Hz
Receiver Detector:	Q.P. and AV.	Tested By:	Yvonne Chen
		Tested Date:	Jan. 15, 2007

Power Line Measured : Line

Freq. (MHz)	Correct. Factor (dB)	Reading Value (dB μ V)		Emission Level (dB μ V)		Limit (dB μ V)		Margin (dB)	
		Q.P.	AV.	Q.P.	AV.	Q.P.	AV.	Q.P.	AV.
0.189	0.30	39.92	39.54	40.22	39.84	64.06	54.06	-23.84	-14.22
0.192	0.30	39.14	38.63	39.44	38.93	63.93	53.93	-24.49	-15.00
0.884	0.19	31.80	30.87	31.99	31.06	56.00	46.00	-24.01	-14.94
2.022	0.16	35.04	34.30	35.20	34.46	56.00	46.00	-20.80	-11.54
2.091	0.16	33.72	26.38	33.88	26.54	56.00	46.00	-22.12	-19.46
11.821	0.24	31.82	26.59	32.06	26.83	60.00	50.00	-27.94	-23.17

Power Line Measured : Neutral

Freq. (MHz)	Correct. Factor (dB)	Reading Value (dB μ V)		Emission Level (dB μ V)		Limit (dB μ V)		Margin (dB)	
		Q.P.	AV.	Q.P.	AV.	Q.P.	AV.	Q.P.	AV.
0.189	0.30	39.74	38.68	40.04	38.98	64.06	54.06	-24.02	-15.08
0.192	0.30	39.14	37.76	39.44	38.06	63.93	53.93	-24.49	-15.87
0.884	0.19	32.68	31.84	32.87	32.03	56.00	46.00	-23.13	-13.97
4.932	0.22	32.08	27.02	32.30	27.24	56.00	46.00	-23.70	-18.76
4.992	0.22	32.98	29.40	33.20	29.62	56.00	46.00	-22.80	-16.38
5.122	0.22	31.84	26.11	32.06	26.33	60.00	50.00	-27.94	-23.67

NOTE :

1. Measurement uncertainty is +/-1.32dB
2. Emission level = Reading value + Correction factor
3. Correction Factor = Cable loss + Insertion loss of LISN
4. Margin value = Emission level - Limit
5. The emission of other frequencies were very low against the limit.
6. "-": The Quasi-peak reading value also meets average limit and measurement with the average detector is unnecessary.

**Spectrum Research & Testing Lab., Inc.**No. 101-10, Ling 8,
Shan-Tong Li, Chung-Li
City, Taoyuan, Taiwan,
R.O.C.**TEST REPORT**Reference No.:A07010302
Report No.:FCCA07010302
FCC ID: HV4DTZ2000W
Page:13 of 29
Date: Feb. 06, 2007

Temperature:	24 °C	Humidity:	76 %RH
Ferquency Range:	0.15 – 30 MHz	Tested Mode 4:	Adapter 2(VGA) 1680*1050 60Hz
Receiver Detector:	Q.P. and AV.	Tested By:	Yvonne Chen
		Tested Date:	Jan. 15, 2007

Power Line Measured : Line

Freq. (MHz)	Correct. Factor (dB)	Reading Value (dB μ V)		Emission Level (dB μ V)		Limit (dB μ V)		Margin (dB)	
		Q.P.	AV.	Q.P.	AV.	Q.P.	AV.	Q.P.	AV.
0.189	0.30	39.60	38.89	39.90	39.19	64.06	54.06	-24.16	-14.87
0.192	0.30	40.18	39.29	40.48	39.59	63.93	53.93	-23.45	-14.34
0.870	0.19	30.96	30.32	31.15	30.51	56.00	46.00	-24.85	-15.49
1.972	0.16	33.64	31.63	33.80	31.79	56.00	46.00	-22.20	-14.21
2.032	0.16	34.14	33.21	34.30	33.37	56.00	46.00	-21.70	-12.63
9.151	0.23	32.12	27.15	32.35	27.38	60.00	50.00	-27.65	-22.62

Power Line Measured : Neutral

Freq. (MHz)	Correct. Factor (dB)	Reading Value (dB μ V)		Emission Level (dB μ V)		Limit (dB μ V)		Margin (dB)	
		Q.P.	AV.	Q.P.	AV.	Q.P.	AV.	Q.P.	AV.
0.189	0.30	38.26	36.99	38.56	37.29	64.06	54.06	-25.50	-16.77
0.192	0.30	38.76	37.11	39.06	37.41	63.93	53.93	-24.87	-16.52
0.889	0.19	32.02	29.15	32.21	29.34	56.00	46.00	-23.79	-16.66
2.289	0.16	31.50	25.44	31.66	25.60	56.00	46.00	-24.34	-20.40
12.623	0.24	31.62	26.02	31.86	26.26	60.00	50.00	-28.14	-23.74
15.533	0.26	31.92	25.05	32.18	25.31	60.00	50.00	-27.82	-24.69

NOTE :

1. Measurement uncertainty is +/-1.32dB
2. Emission level = Reading value + Correction factor
3. Correction Factor = Cable loss + Insertion loss of LISN
4. Margin value = Emission level - Limit
5. The emission of other frequencies were very low against the limit.
6. "-": The Quasi-peak reading value also meets average limit and measurement with the average detector is unnecessary.



Temperature:	24 °C	Humidity:	76 %RH
Ferquency Range:	0.15 – 30 MHz	Tested Mode 5:	Adapter 3(DVI) 1680*1050 60Hz
Receiver Detector:	Q.P. and AV.	Tested By:	Yvonne Chen
		Tested Date:	Jan. 15, 2007

Power Line Measured : Line

Freq. (MHz)	Correct. Factor (dB)	Reading Value (dB μ V)		Emission Level (dB μ V)		Limit (dB μ V)		Margin (dB)	
		Q.P.	AV.	Q.P.	AV.	Q.P.	AV.	Q.P.	AV.
0.159	0.30	57.32	46.99	57.62	47.29	65.50	55.50	-7.88	-8.21
0.162	0.30	56.04	40.81	56.34	41.11	65.34	55.34	-9.00	-14.23
0.529	0.24	28.02	12.55	28.26	12.79	56.00	46.00	-27.74	-33.21
3.012	0.18	28.02	19.43	28.20	19.61	56.00	46.00	-27.80	-26.39
3.378	0.19	27.94	20.27	28.13	20.46	56.00	46.00	-27.87	-25.54
27.813	0.45	28.48	19.75	28.93	20.20	60.00	50.00	-31.07	-29.80

Power Line Measured : Neutral

Freq. (MHz)	Correct. Factor (dB)	Reading Value (dB μ V)		Emission Level (dB μ V)		Limit (dB μ V)		Margin (dB)	
		Q.P.	AV.	Q.P.	AV.	Q.P.	AV.	Q.P.	AV.
0.153	0.30	55.32	42.83	55.62	43.13	65.82	55.82	-10.20	-12.69
0.159	0.30	56.48	46.30	56.78	46.60	65.50	55.50	-8.72	-8.90
0.514	0.24	28.06	13.24	28.30	13.48	56.00	46.00	-27.70	-32.52
3.101	0.18	31.16	22.47	31.34	22.65	56.00	46.00	-24.66	-23.35
3.150	0.18	30.92	22.70	31.10	22.88	56.00	46.00	-24.90	-23.12
27.915	0.31	29.78	19.49	30.09	19.80	60.00	50.00	-29.91	-30.20

NOTE :

1. Measurement uncertainty is +/-1.32dB
2. Emission level = Reading value + Correction factor
3. Correction Factor = Cable loss + Insertion loss of LISN
4. Margin value = Emission level - Limit
5. The emission of other frequencies were very low against the limit.
6. "-": The Quasi-peak reading value also meets average limit and measurement with the average detector is unnecessary.



Temperature:	<u>24 °C</u>	Humidity:	<u>76 %RH</u>
Ferquency Range:	<u>0.15 – 30 MHz</u>	Tested Mode 6:	<u>Adapter 3(VGA) 1680*1050 60Hz</u>
Receiver Detector:	<u>Q.P. and AV.</u>	Tested By:	<u>Yvonne Chen</u>
		Tested Date:	<u>Jan. 15, 2007</u>

Power Line Measured : Line

Freq. (MHz)	Correct. Factor (dB)	Reading Value (dB μ V)		Emission Level (dB μ V)		Limit (dB μ V)		Margin (dB)	
		Q.P.	AV.	Q.P.	AV.	Q.P.	AV.	Q.P.	AV.
0.150	0.30	51.84	38.60	52.14	38.90	66.00	56.00	-13.86	-17.10
0.156	0.30	51.94	40.42	52.24	40.72	65.66	55.66	-13.42	-14.94
0.524	0.24	28.28	11.08	28.52	11.32	56.00	46.00	-27.48	-34.68
1.517	0.15	29.78	10.45	29.93	10.60	56.00	46.00	-26.07	-35.40
2.358	0.17	26.86	17.80	27.03	17.97	56.00	46.00	-28.97	-28.03
13.709	0.24	26.16	21.80	26.40	22.04	60.00	50.00	-33.60	-27.96

Power Line Measured : Neutral

Freq. (MHz)	Correct. Factor (dB)	Reading Value (dB μ V)		Emission Level (dB μ V)		Limit (dB μ V)		Margin (dB)	
		Q.P.	AV.	Q.P.	AV.	Q.P.	AV.	Q.P.	AV.
0.150	0.30	52.26	39.56	52.56	39.86	66.00	56.00	-13.44	-16.14
0.156	0.30	52.38	42.13	52.68	42.43	65.66	55.66	-12.98	-13.23
0.529	0.24	28.38	5.72	28.62	5.96	56.00	46.00	-27.38	-40.04
3.170	0.18	32.16	21.48	32.34	21.66	56.00	46.00	-23.66	-24.34
3.220	0.18	32.56	22.12	32.74	22.30	56.00	46.00	-23.26	-23.70
17.296	0.27	26.88	21.57	27.15	21.84	60.00	50.00	-32.85	-28.16

NOTE :

1. Measurement uncertainty is +/-1.32dB
2. Emission level = Reading value + Correction factor
3. Correction Factor = Cable loss + Insertion loss of LISN
4. Margin value = Emission level - Limit
5. The emission of other frequencies were very low against the limit.
6. "-": The Quasi-peak reading value also meets average limit and measurement with the average detector is unnecessary.

**Spectrum Research & Testing Lab., Inc.**No. 101-10, Ling 8,
Shan-Tong Li, Chung-Li
City, Taoyuan, Taiwan,
R.O.C.**TEST REPORT**Reference No.:A07010302
Report No.:FCCA07010302
FCC ID: HV4DTZ2000W
Page:16 of 29
Date: Feb. 06, 2007

Temperature:	24 °C	Humidity:	76 %RH
Ferquency Range:	0.15 – 30 MHz	Tested Mode 7:	Adapter 4(DVI) 1680*1050 60Hz
Receiver Detector:	Q.P. and AV.	Tested By:	Yvonne Chen
		Tested Date:	Jan. 15, 2007

Power Line Measured : Line

Freq. (MHz)	Correct. Factor (dB)	Reading Value (dB μ V)		Emission Level (dB μ V)		Limit (dB μ V)		Margin (dB)	
		Q.P.	AV.	Q.P.	AV.	Q.P.	AV.	Q.P.	AV.
0.189	0.30	51.98	42.06	52.28	42.36	64.06	54.06	-11.78	-11.70
0.192	0.30	51.68	41.90	51.98	42.20	63.93	53.93	-11.95	-11.73
3.111	0.18	37.20	24.63	37.38	24.81	56.00	46.00	-18.62	-21.19
13.648	0.24	44.68	34.97	44.92	35.21	60.00	50.00	-15.08	-14.79
13.962	0.25	46.80	36.10	47.05	36.35	60.00	50.00	-12.95	-13.65
15.359	0.26	48.80	38.17	49.06	38.43	60.00	50.00	-10.94	-11.57

Power Line Measured : Neutral

Freq. (MHz)	Correct. Factor (dB)	Reading Value (dB μ V)		Emission Level (dB μ V)		Limit (dB μ V)		Margin (dB)	
		Q.P.	AV.	Q.P.	AV.	Q.P.	AV.	Q.P.	AV.
0.189	0.30	51.66	42.22	51.96	42.52	64.06	54.06	-12.10	-11.54
0.192	0.30	51.54	42.19	51.84	42.49	63.93	53.93	-12.09	-11.44
3.041	0.18	37.46	26.55	37.64	26.73	56.00	46.00	-18.36	-19.27
13.770	0.24	45.80	35.68	46.04	35.92	60.00	50.00	-13.96	-14.08
14.917	0.25	43.68	34.56	43.93	34.81	60.00	50.00	-16.07	-15.19
15.031	0.25	45.68	35.40	45.93	35.65	60.00	50.00	-14.07	-14.35

NOTE :

1. Measurement uncertainty is +/-1.32dB
2. Emission level = Reading value + Correction factor
3. Correction Factor = Cable loss + Insertion loss of LISN
4. Margin value = Emission level - Limit
5. The emission of other frequencies were very low against the limit.
6. "-": The Quasi-peak reading value also meets average limit and measurement with the average detector is unnecessary.



Temperature:	24 °C	Humidity:	76 %RH
Ferquency Range:	0.15 – 30 MHz	Tested Mode 8:	Adapter 4(VGA) 1680*1050 60Hz
Receiver Detector:	Q.P. and AV.	Tested By:	Yvonne Chen
		Tested Date:	Jan. 15, 2007

Power Line Measured : Line

Freq. (MHz)	Correct. Factor (dB)	Reading Value (dB μ V)		Emission Level (dB μ V)		Limit (dB μ V)		Margin (dB)	
		Q.P.	AV.	Q.P.	AV.	Q.P.	AV.	Q.P.	AV.
0.189	0.30	50.26	40.64	50.56	40.94	64.06	54.06	-13.50	-13.12
0.192	0.30	50.22	40.72	50.52	41.02	63.93	53.93	-13.41	-12.91
3.170	0.18	39.90	28.24	40.08	28.42	56.00	46.00	-15.92	-17.58
14.835	0.25	48.86	35.86	49.11	36.11	60.00	50.00	-10.89	-13.89
14.845	0.25	49.68	39.43	49.93	39.68	60.00	50.00	-10.07	-10.32
15.164	0.25	49.52	39.67	49.77	39.92	60.00	50.00	-10.23	-10.08

Power Line Measured : Neutral

Freq. (MHz)	Correct. Factor (dB)	Reading Value (dB μ V)		Emission Level (dB μ V)		Limit (dB μ V)		Margin (dB)	
		Q.P.	AV.	Q.P.	AV.	Q.P.	AV.	Q.P.	AV.
0.189	0.30	49.50	39.39	49.80	39.69	64.06	54.06	-14.26	-14.37
0.192	0.30	49.42	39.33	49.72	39.63	63.93	53.93	-14.21	-14.30
2.853	0.18	34.68	24.35	34.86	24.53	56.00	46.00	-21.14	-21.47
14.845	0.25	49.04	39.68	49.29	39.93	60.00	50.00	-10.71	-10.07
14.967	0.25	47.10	38.71	47.35	38.96	60.00	50.00	-12.65	-11.04
15.031	0.25	47.76	39.04	48.01	39.29	60.00	50.00	-11.99	-10.71

NOTE :

1. Measurement uncertainty is +/-1.32dB
2. Emission level = Reading value + Correction factor
3. Correction Factor = Cable loss + Insertion loss of LISN
4. Margin value = Emission level - Limit
5. The emission of other frequencies were very low against the limit.
6. "-": The Quasi-peak reading value also meets average limit and measurement with the average detector is unnecessary.



5. RADIATED EMISSION TEST

5.1 RADIATED EMISSION LIMIT

FCC Part 15, Subpart B Section 15.209.

FREQUENCY (MHz)	DISTANCE (m)	FIELD STRENGTH ($\mu\text{V}/\text{m}$)
0.009 - 0.490	300	2400/F(kHz)
0.490 -1.705	300	24000/F(kHz)
1.705 - 30.0	30	30
30 - 88	3	100
88 - 216	3	150
216 - 960	3	200
ABOVE 960	3	500

NOTE :

1. In the emission tables above, the tighter limit applies at the band edges.
2. Distance refers to the distance between measuring instrument, antenna, and the closest point of any part of the device or system.

FCC Part 15, Subpart A Section 15.31(f)(2) Extrapolation factor of 40 dB/decade for measurement distances different then specified in with limits for frequencies below 30 MHz.

FCC Part15, Subpart C Section 15.209 limit of radiated emission for frequency below1000MHz. The emissions from an intentional radiator shall not exceed the field strength levels specified in the following table:

FREQUENCY (MHz)	DISTANCE (m)	FIELD STRENGTH (dB $\mu\text{V}/\text{m}$)
30 - 88	3	40.0
88 - 216	3	43.5
216 - 960	3	46.0
Above 960	3	54.0

NOTE :

1. In the emission tables above , the tighter limit applies at the band edges.
2. Distance refers to the distance between measuring instrument, antenna, and the closest point of any part of the device or system.

**Spectrum Research & Testing Lab., Inc.**

No. 101-10, Ling 8,
Shan-Tong Li, Chung-Li
City, Taoyuan, Taiwan,
R.O.C.

TEST REPORT

Reference No.:A07010302
Report No.:FCCA07010302
FCC ID: HV4DTZ2000W
Page:19 of 29
Date: Feb. 06, 2007

5.2 TEST EQUIPMENT

The following test equipment was used during the radiated emission test:

EQUIPMENT/ FACILITIES	SPECIFICATIONS	MANUFACTURER	MODEL#/ SERIAL#	DUE DATE OF CAL. & CAL. CENTER
EMI TEST RECEIVER	20 kHz TO 1 GHz	ROHDE & SCHWARZ	ESCS30/ 830245/012	OCT. 2007 ETC
BI-LOG ANTENNA	25 MHz TO 2 GHz	EMCO	3143/ 9509-1141	SEP. 2007 SRT
OATS	3 – 10 M MEASUREMENT	SRT	SRT-1	DEC. 2007 SRT
COAXIAL CABLE	25M	SUNCITY	J400/ 25M	JUN. 2007 SRT
FILTER	2 LINE, 30A	FIL.COIL	FC-943/ 869	N/A
FREQUENCY CONVERTER	N/A	APC	AFC-2KBB/ F100030031	AUG. 2007 SRT
LOOP ANTENNA	9 kHz TO 30 MHz	SCHWARZ	HFH-Z2/ 1162 1/2	JAN. 2008 R&S
ANECHOIC CHAMBER	733	SRT	A03/ SRT003	N/A

NOTE:

1. The calibration interval of the above test equipment is one year and the calibrations are traceable to NML/ROC and NIST/USA.
2. The Open Area Test Site (SRT-1) is registered by FCC with No. 90957 and VCCI with No. R-1081.
3. The Open Area Test Site (SRT-2) is registered by FCC with No. 98458 and VCCI with No. R-1168.



5.3 TEST SET-UP(9KHz ~ 30MHz)

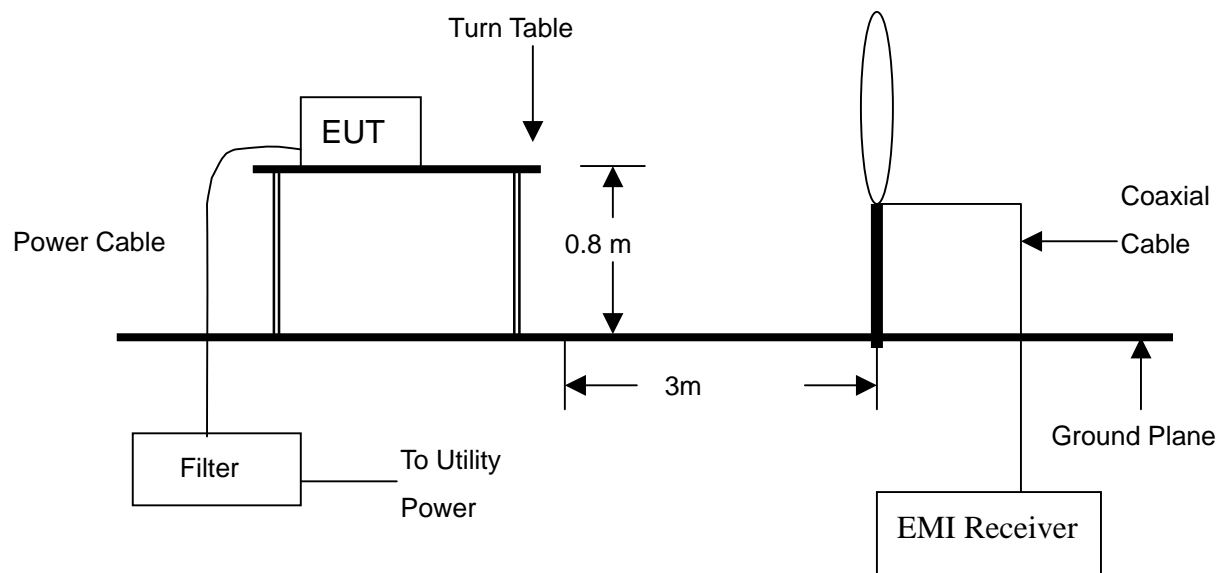

NOTE :

1. The EUT system was put on a wooden table with 0.8m heights above a ground plane.
2. For the actual test configuration, please refer to the photos of testing.



(30MHz ~ 1000MHz)

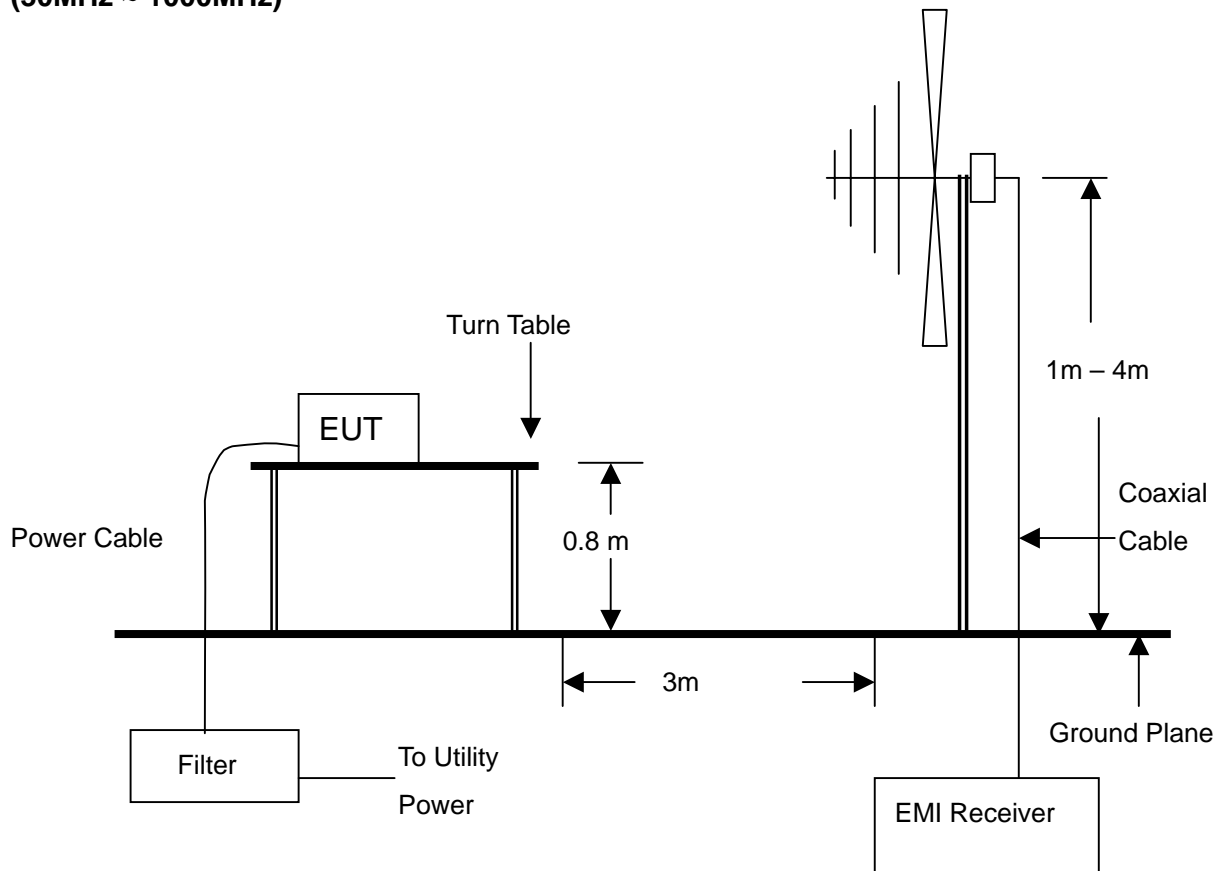

NOTE :

1. The EUT system was put on a wooden table with 0.8m heights above a ground plane.
2. For the actual test configuration, please refer to the photos of testing.



**Spectrum Research
& Testing Lab., Inc.**

No. 101-10, Ling 8,
Shan-Tong Li, Chung-Li
City, Taoyuan, Taiwan,
R.O.C.

TEST REPORT

Reference No.:A07010302
Report No.:FCCA07010302
FCC ID: HV4DTZ2000W
Page:22 of 29
Date: Feb. 06, 2007

5.4 TEST PROCEDURE

The EUT was tested according to the requirement of ANSI C63.4:2003. The measurements were made at an open area test site with 3 meter measurement distance. The test receiver captured the test result plot and delta mark to 26dBc. Then printed out the plot on screen of the test receiver.

5.5 EUT OPERATING CONDITION

Same as section 4.5 of this report.



5.6 RADIATED EMISSION TEST RESULT

Temperature:	23 °C	Humidity:	72 %RH
Frequency Range:	30 – 1000 MHz	Measured Distance:	3 m
Receiver Detector:	Q.P.	Tested Mode 1:	DVI
Tested By:	Yvonne Chen	Tested Date:	Jan. 18, 2007

Antenna Polarization: Horizontal

Frequency (MHz)	Cable Loss (dB)	Antenna Factor (dB/m)	Reading Data (dB μ V)	Emission Level (dB μ V/m)	Limit (dB μ V/m)	Margin (dB)	AZ(°)	EL(m)
154.0000	2.10	10.40	22.0	34.5	43.5	-9.0	158.2	4.0
175.2500	2.33	9.40	21.2	32.9	43.5	-10.6	234.6	4.0
250.7145	2.78	12.28	20.2	35.3	46.0	-10.7	20.0	3.9
333.6250	3.21	16.74	21.0	40.9	46.0	-5.1	198.2	3.6
697.2550	5.09	21.34	15.1	41.5	46.0	-4.5	313.0	2.9

Antenna Polarization: Vertical

Frequency (MHz)	Cable Loss (dB)	Antenna Factor (dB/m)	Reading Data (dB μ V)	Emission Level (dB μ V/m)	Limit (dB μ V/m)	Margin (dB)	AZ(°)	EL(m)
120.1250	1.88	5.85	23.5	31.2	43.5	-12.3	201.4	1.0
250.7140	2.78	12.28	22.1	37.2	46.0	-8.8	133.2	1.1
340.1250	3.29	17.96	21.0	42.3	46.0	-3.7	147.6	1.3
605.1500	4.62	19.30	18.6	42.5	46.0	-3.5	12.0	1.6
651.6625	4.86	20.04	17.1	42.0	46.0	-4.0	177.4	1.6

NOTE :

1. Measurement uncertainty is +/-2dB.
2. "*": Measurement does not apply for this frequency.
3. Emission Level = Reading Value + Ant. Factor + Cable Loss.
4. The field strength of other emission frequencies were very low against the limit.

**Spectrum Research & Testing Lab., Inc.**No. 101-10, Ling 8,
Shan-Tong Li, Chung-Li
City, Taoyuan, Taiwan,
R.O.C.**TEST REPORT**Reference No.:A07010302
Report No.:FCCA07010302
FCC ID: HV4DTZ2000W
Page:24 of 29
Date: Feb. 06, 2007

Temperature:	23 °C	Humidity:	72 %RH
Ferquency Range:	30 – 1000 MHz	Measured Distance:	3 m
Receiver Detector:	Q.P.	Tested Mode 1:	VGA
Tested By:	Yvonne Chen	Tested Date:	Jan. 18, 2007

Antenna Polarization: Horizontal

Frequency (MHz)	Cable Loss (dB)	Antenna Factor (dB/m)	Reading Data (dBµV)	Emission Level (dBµV/m)	Limit (dBµV/m)	Margin (dB)	AZ(°)	EL(m)
150.1500	2.06	10.54	21.1	33.7	43.5	-9.8	258.1	4.0
177.5100	2.33	9.36	19.5	31.2	43.5	-12.3	159.6	3.8
250.7145	2.78	12.28	22.5	37.6	46.0	-8.4	321.4	3.7
332.6500	3.20	16.56	21.3	41.1	46.0	-4.9	10.2	3.4
592.3600	4.64	19.20	20.0	43.8	46.0	-2.2	147.5	3.0

Antenna Polarization: Vertical

Frequency (MHz)	Cable Loss (dB)	Antenna Factor (dB/m)	Reading Data (dBµV)	Emission Level (dBµV/m)	Limit (dBµV/m)	Margin (dB)	AZ(°)	EL(m)
250.7150	2.78	12.28	22.3	37.4	46.0	-8.6	315.2	1.0
340.1255	3.29	17.96	21.1	42.4	46.0	-3.6	268.3	1.3
511.1250	4.19	18.33	19.4	41.9	46.0	-4.1	152.3	1.4
600.1400	4.58	19.20	19.1	42.9	46.0	-3.1	132.2	1.6
651.6625	4.86	20.04	16.3	41.2	46.0	-4.8	258.3	1.6

NOTE :

1. Measurement uncertainty is +/-2dB.
2. "**": Measurement does not apply for this frequency.
3. Emission Level = Reading Value + Ant. Factor + Cable Loss.
4. The field strength of other emission frequencies were very low against the limit.

**Spectrum Research & Testing Lab., Inc.**No. 101-10, Ling 8,
Shan-Tong Li, Chung-Li
City, Taoyuan, Taiwan,
R.O.C.**TEST REPORT**Reference No.:A07010302
Report No.:FCCA07010302
FCC ID: HV4DTZ2000W
Page:25 of 29
Date: Feb. 06, 2007

Temperature:	22 °C	Humidity:	65 %RH
Frequency Range:	9K-30MHz	Measured Distance:	3m
Receiver Detector:	P.K.	Tested Mode:	DVI
Tested By:	Lily Yang	Tested Date:	Feb. 06, 2007

Frequency (MHz)	Factor (dB)	Reading Data (dB μ V)	Emission Level (dB μ V/m)	Limit (dB μ V/m)	Margin (dB)
0.6770 (F)	20.10	38.2	58.3	71.1	-12.8
1.3340	20.09	22.7	42.8	65.1	-22.3
2.0010	20.08	15.3	35.4	61.6	-26.2
2.6680	20.07	9.3	29.4	59.1	-29.7
3.3350	20.05	7.1	27.1	57.1	-30.0

Temperature:	22 °C	Humidity:	65 %RH
Frequency Range:	9K-30MHz	Measured Distance:	3m
Receiver Detector:	P.K.	Tested Mode:	VGA
Tested By:	Lily Yang	Tested Date:	Feb. 06, 2007

Frequency (MHz)	Factor (dB)	Reading Data (dB μ V)	Emission Level (dB μ V/m)	Limit (dB μ V/m)	Margin (dB)
0.6770 (F)	20.10	39.9	60.0	71.0	-11.0
1.3340	20.09	33.1	53.2	65.1	-12.0
2.0010	20.08	23.9	44.0	61.6	-17.6
2.6680	20.07	13.3	33.4	59.1	-25.7
3.3350	20.05	9.6	29.6	57.1	-27.5

**Spectrum Research
& Testing Lab., Inc.**

No. 101-10, Ling 8,
Shan-Tong Li, Chung-Li
City, Taoyuan, Taiwan,
R.O.C.

TEST REPORT

Reference No.:A07010302
Report No.:FCCA07010302
FCC ID: HV4DTZ2000W
Page:29 of 29
Date: Feb. 06, 2007

7. TERMS OF ABBREVIATION

AV.	Average detection
AZ(°)	Turn table azimuth
Correct.	Correction
EL(m)	Antenna height (meter)
EUT	Equipment Under Test
Horiz.	Horizontal direction
LISN	Line Impedance Stabilization Network
NSA	Normalized Site Attenuation
Q.P.	Quasi-peak detection
SRT Lab	Spectrum Research & Testing Laboratory, Inc.
Vert.	Vertical direction