

wacom®

MobileStudio Pro

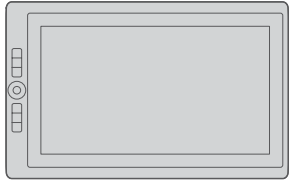

1x

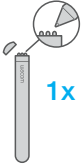

1x



1x



1x



1x

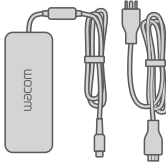

1x



1x



1x

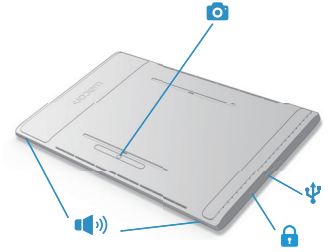
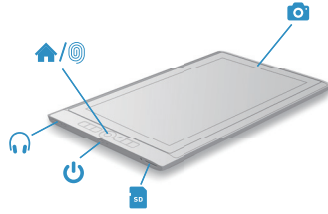

1

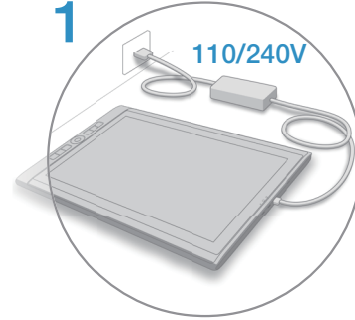

2

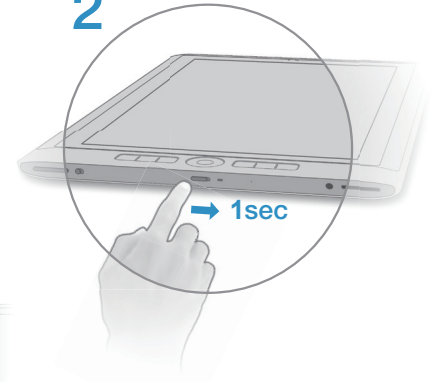

3

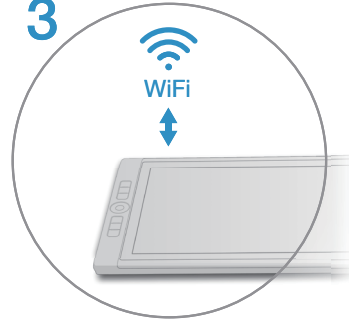

www.wacom.com

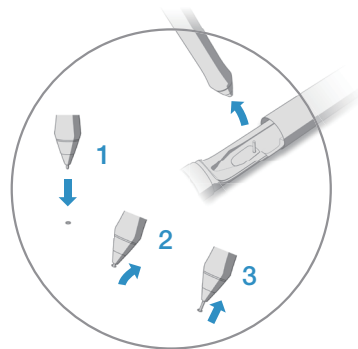
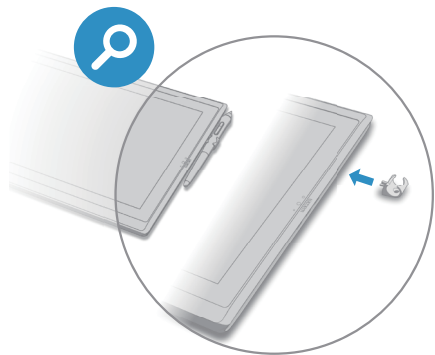

© 2016 Wacom Co., Ltd. All rights reserved. Wacom, MobileStudio Pro and their respective logos are trademarks and/or registered trademarks of Wacom Co., Ltd.

© 2016 Wacom Co., Ltd. All rights reserved. Wacom, MobileStudio Pro and their respective logos are trademarks and/or registered trademarks of Wacom Co., Ltd.

Printed in China



WACOM™

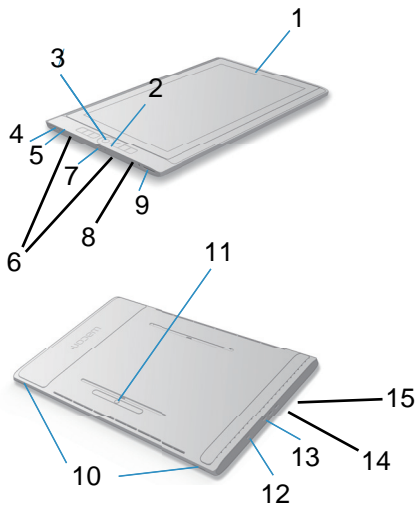

1. Front Camera
2. LED indicators
3. Windows home key
4. Volume Button
5. Panel lock
6. Microphone
7. Power Button
8. Headset Jack
9. SDXC card reader
10. Speaker
11. Rear Camera
12. Kensington Security Slot
13. USB Type C Port A
14. USB Type C Port B
15. USB Type C Port C

Use case

-Tablet mode

In this mode the product will be used on its own on a tablet or desk surface using a Multi-position stand to facilitate drawing comfort or may be used in a lap in a or other "casual" location.

-Pen Display mode

In Pen Display mode the user connects the tablet to a host external computer.

The host takes over the screen of the tablet and it performs like a standard Cintiq pen display.

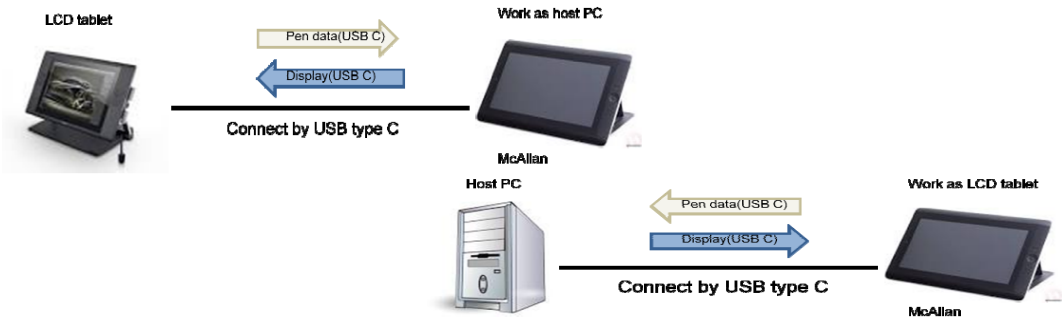

Wacom® MobileStudio Pro

DTH-W1320, DTH-W1620



REGULATORY STATEMENT

FCC notice

This device complies with Part 15 of the FCC Rules. Operation is subject to the following two conditions: (1) This device may not cause harmful interference, and (2) this device must accept any interference received, including interference that may cause undesired operation. This equipment has been tested and found to comply with the limits for a Class B digital device, pursuant to Part 15 of FCC Rules. These limits are designed to provide reasonable protection against harmful interference in a residential installation. This equipment generates, uses and can radiate radio frequency energy and if not installed and used in accordance with the instructions may cause harmful interference to communications. However, there is no guarantee that interference will not occur in a particular installation. You can determine whether the equipment is causing interference by disconnecting it from your computer. If the interference stops, it was probably caused by the equipment. If the equipment does cause interference to radio or television reception, you may be able to correct the interference by using one or more of the following measures:

- Rotate the television or radio antenna until the interference stops.
- Move the equipment farther away from the television or radio.
- Plug the equipment and computer into an outlet that is on a different circuit from the television or radio.

If necessary, consult your Wacom dealer or an experienced radio/television technician for help. Changes or modifications to this product not authorized by Wacom could void the FCC Certification and negate your authority to operate the product. FCC Caution: Any changes or modifications not expressly approved by the party responsible for compliance could void the user's authority to operate this equipment. This equipment must not be co-located or operating in conjunction with any other antenna or transmitter. FCC RF Radiation Exposure Statement: This device meets the government's requirements for exposure to radio waves.

This device is designed and manufactured not to exceed the emission limits for exposure to radio frequency (RF) energy set by the Federal Communications Commission of the U.S. Government. The exposure standard for wireless devices employs a unit of measurement known as the Specific Absorption Rate, or SAR. The SAR limit set by the FCC is 1.6W/kg. Tests for SAR are conducted using standard operating positions accepted by the FCC with the device transmitting at its highest certified power level in all tested frequency bands. Federal Communication Commission (FCC) Radiation Exposure Statement: This equipment complies with FCC radiation exposure limits set forth for an uncontrolled environment. End user must follow the specific operating instructions for satisfying RF exposure compliance. About regulatory access information:

To view the FCC ID, Step 1: Shut down your device. Step 2: Press and hold the volume-up button on your device, and, at the same time, slide and release the power button. Step 3: When you see the Wacom logo, release the volume-up button. The BIOS menu will appear within a few seconds. Step 4: Tap Regulatory to view FCC ID.

To view the FCC ID, Step 1: Shut down your device. Step 2: Press and hold the volume-up button on your device, and, at the same time, slide and release the power button. Step 3: When you see the Wacom logo, release the volume-up button. The BIOS menu will appear within a few seconds. Step 4: Tap Regulatory to view FCC ID.

Industry Canada

This device complies with Industry Canada's licence-exempt RSSs. Operation is subject to the following two conditions: This device may not cause interference, and This device must accept any interference, including interference that may cause undesired operation of the device. • This device and its antenna(s) must not be co-located or operating in conjunction with any other antenna or transmitter, except tested built-in radios. • Cet appareil et son antenne ne doivent pas être situés ou fonctionner en conjonction avec une autre antenne ou un autre émetteur, excepté des radios intégrées qui ont été testées. • Le Code Sélection de l'appareil doit être désactivé pour les produits commercialisés aux États-Unis et au Canada. • La fonction de sélection de l'indicatif du pays est désactivée pour les produits commercialisés aux États-Unis et au Canada. Radiation Exposure Statement: This product Complies with the Canada portable RF exposure limit set forth for an uncontrolled environment and are safe for intended operation as described in this document. The further RF exposure reduction can be achieved if the product can be kept as far as possible from the user's body or set the device to lower output power if such function is available. This EUT is compliance with SAR for general population/uncontrolled exposure limits in IC RSS-102 and had been tested in accordance with the measurement methods and procedures specified in IEEE 1528. When using the 5GHz band: The device for operation in the band 5150-5250 MHz is only for indoor use to reduce the potential for harmful interference to co-channel mobile satellite systems; High-power radars are allocated as primary users of the bands 5250-5350 MHz and 5650-5850 MHz and that these radars could cause interference and/or damage to Licence-Exempt Local Area Network devices. This device is restricted to indoor use.

EU CONFORMITY INFORMATION

The product complies with European EMC, R&TTE, ErP and RoHS Directive. See: www.wacom.eu/certificates



This equipment complies with the RF exposure requirements in Europe.

ENERGY STAR® compliance

The ENERGY STAR program for computers was created by the EPA to promote energy efficiency and reduce air pollution through more energy-efficient equipment in homes, offices, and factories. One way that products achieve this goal is by using the Microsoft® Windows® power management feature to reduce power consumption when the product is not in use. The computer exits Sleep when the power/Sleep button is pressed. When the Wake On LAN (WOL) feature is enabled, the computer can also exit Sleep in response to a network signal.

As a member company of the International Energy Star Program, we judge that this product conforms to the standard of the International Energy Star Program.

This computer is designed in compliance with the ENERGY STAR standards and delivered with the following power saving settings that apply to the computer running on AC power:

- The LCD backlight is turned off automatically after no more than 15 minutes of inactivity.
- The computer enters Sleep mode automatically after no more than 30 minutes of inactivity.

ENVIRONMENTAL COMPLIANCE

UNITED STATES E-WASTE PROGRAM

Wacom Technology, as a manufacturer of electronic monitors, is subject to and fully compliant with eWaste legislation in various states. For more information on the collection sites and statewide eWaste recycling programs in the United States, please visit: <http://www.wacom.com/eWaste> or call 1-800-922-6613

For customers in the USA and Canada recycling Lithium-Ion Batteries

You can help preserve our environment by returning your used rechargeable batteries to the collection and recycling location nearest you. For more information regarding recycling of rechargeable batteries, call toll free 1-800-922-8837, or visit <http://www.rbc.org/>. Caution: Do not handle damaged or leaking LI-Ion battery.



WEEE

Reuse, recycling, and recovery. You are urged to recycle this product when replacing it with a newer product or when it has outlived its useful life by bringing it to an appropriate collection point for recyclable materials in your community or region. By doing this, you can help improve the environment of your community as well as minimize the potential negative effects created should any hazardous substance that may possibly be present within waste material reach the environment during the disposal process. Within the European Union, users are required not to dispose of Waste Electrical and Electronic Equipment (WEEE) as unsorted municipal waste, according to the WEEE Directive or the corresponding local laws of the Member States. Products for which this is applicable will be marked with the WEEE symbol shown at the beginning of this note unless this is not feasible because of the size or the function of the product. Wacom products are subject to the Directive WEEE and therefore you should always collect them separately and bring them to the appropriate collection point in your community or region.

EU BATTERY DISPOSAL INFORMATION

Note: This symbol mark is for EU countries only. This symbol mark is according to the directive 2006/66/EC Article 20. Information for end-users and Annex II. Your product is designed and manufactured with high quality materials and components which can be recycled and/or reused. This symbol means that batteries and accumulators, at their end-of-life, should be disposed of separately from your household waste. In the European Union there are separate collection systems for used Batteries and accumulators. Please, dispose of batteries and accumulators correctly at your local community waste collection/recycling centre. Please, help us to conserve the environment we live in!

ErP Directive

Do not attempt to access, remove, repair, replace, or alter the battery of your product. If you have a problem with the battery, please contact the Wacom Support for your region.

DE

RECHTLICHE HINWEISE

EU-KONFORMITÄTSINFORMATION Das Produkt erfüllt die Anforderungen der europäischen Richtlinien EMC, R&TTE, ErP sowie RoHS. Siehe: www.wacom.eu/certificates



EINHALTUNG VON UMWELTSTANDARDS

WEEE-RICHTLINIE Wiederverwendung, Recycling und Reparatur. Wenn Sie das Gerät durch ein neues ersetzen oder die Nutzungsdauer des Geräts abgelaufen ist, sollten Sie das Produkt bei einer Recycling-Sammelstelle in Ihrer Nähe abgeben. Sie leisten dadurch einen aktiven Beitrag zum Umweltschutz in Ihrer Gemeinde und tragen dazu bei, dass keinerlei in dem Gerät vorhandene Schadstoffe bei der Entsorgung in die Umwelt gelangen.

Gemäß der WEEE-Richtlinie und laut Vorschriften in den einzelnen Mitgliedsstaaten ist die Entsorgung von Elektro- und Elektronikschrott im normalen Hausmüll untersagt. Produkte, auf die diese Richtlinie zutreffen, sind mit dem Symbol zur Kennzeichnung von Elektro- und Elektronikgeräten am Anfang dieses Hinweises versehen, es sei denn, diese Kennzeichnung ist aufgrund des Formats oder der Funktion des Produkts nicht möglich. Produkte von Wacom unterliegen der WEEE-Richtlinie. Die Geräte sollten daher stets getrennt gesammelt und der entsprechenden Entsorgungsstelle in Ihrer Region oder Gemeinde zugeführt werden.

INFORMATIONEN DER EU ZUR ENTSORGUNG VON BATTERIEN

Hinweis: Dieses Symbol gilt nur für EU-Staaten. Dieses Symbol wird gemäß der Richtlinie 2006/66/EG Artikel 20. Informationen für Endverbraucher, Anhang II, verwendet. Dieses Produkt wurde unter Verwendung hochwertiger Materialien und Bestandteile entwickelt und hergestellt, die recycelt und/oder wiederverwendet werden können. Dieses Symbol besagt, dass Batterien und Akkus nach ihrem Lebenszyklus nicht im Hausmüll entsorgt werden dürfen. In der Europäischen Union gibt es unterschiedliche Sammel-systeme für gebrauchte Batterien und Akkus. Bitte entsorgen Sie Batterien und Akkus vorschriftsmäßig bei Ihrer kommunalen Sammel-/Recycling-stelle. Bitte unterstützen Sie uns bei der Erhaltung unserer Umwelt!

Ökodesign-Richtlinie

Versuchen Sie nicht, das Batteriefach dieses Produktes zu öffnen oder dessen Batterie zu entfernen, zu reparieren, auszutauschen oder zu verändern. Bei Problemen mit der Batterie wenden Sie sich bitte an den Wacom Kundendienst für Ihre Region.

NL

WETTELIJKE VERKLARING

INFORMATIE OVER DE EU-KONFORMITEIT Het product voldoet aan de voorschriften van de Europese EMC-, R&TTE-, ErP- alsook de Europese RoHS-richtlijnen. Zie: www.wacom.eu/certificates



MILEURICHTLIJN

WEEE Het tablet hergebruiken, recyclen en opslaan. U wordt verzocht dit product te recyclen wanneer u het vervangt door een nieuw product of wanneer het product het einde van zijn levensduur heeft bereikt. Breng het naar een recyclingpunt in uw buurt. Op die manier levert u uw bijdrage aan een schonere omgeving en voorkomt u dat mogelijk gevaarlijke bestanddelen die verwerkt zijn in het afvalmateriaal in het milieu terechtkomen. Overeenkomstig de WEEE-Richtlijn alsmede plaatselijke wetten van de lidstaten is het aan inwoners van de Europese Unie niet toegestaan om elektrische en elektronische apparatuur als ongesorteerd huishoudelijk afval aan te bieden. Producten waarvoor deze regels gelden, dragen bovenstaand WEEE-symbool, tenzij de omvang of de functie van het product dit niet toelaat. Producten van Wacom vallen onder de bepalingen van de WEEE-Richtlijn en dienen apart naar het desbetreffende verzamel-punt in uw buurt te worden gebracht.

BATTERIJVERWIJDERINGSINFORMATIE EU

Opmerking: Dit symbool is alleen van toepassing op EU-landen. Dit symbool voldoet aan de voorwaarden van richtlijn 2006/66/EG Artikel 20. Informatie voor de eindgebruikers en Bijlage II. Je product is ontworpen en geproduceerd met hoogwaardige materialen en onderdelen die gerecycled en/of opnieuw gebruikt kunnen worden. Dit symbool betekent dat batterijen en accu's aan het einde van hun levensduur afzonderlijk van huishoudelijk afval worden verwijderd. In de Europese Unie zijn afzonderlijke inzamelingsystemen voor gebruikte batterijen en accu's beschikbaar. Verwijder batterijen en accu's op de juiste wijze bij de lokale centrum voor afvalverzameling/recycling. Help ons het milieu waarin we leven te beschermen!

ErP-richtlijn

Probeer de batterij van je product niet te verwijderen, repareren, vervangen of aan te passen of er toegang tot verkrijgen. Als je een probleem hebt met de batterij, neem dan contact op met de Wacom-support voor jouw regio.

FR

AVIS DE CONFORMITÉ

INDUSTRIE CANADA Le présent appareil est conforme aux CNR d'Industrie Canada applicables aux appareils radio exempts de licence. L'exploitation est autorisée aux deux conditions suivantes : (1) l'appareil ne doit pas produire de brouillage, et (2) l'utilisateur de l'appareil doit accepter tout brouillage radioélectrique subi, même si le brouillage est susceptible d'en compromettre le fonctionnement.

Le produit est sûr pour un fonctionnement tel que décrit dans ce manuel. La réduction aux expositions RF peut être augmentée si l'appareil peut être conservé aussi long que possible du corps de l'utilisateur ou que le dispositif est réglé sur la puissance de sortie la plus faible si une telle fonction est disponible. High-power radars are allocated as primary users of the bands 5250-5350 MHz and 5650-5850 MHz and that these radars could cause interference and/or damage to Licence-Exempt Local Area Network devices.

The device for operation in the band 5150-5250 MHz is only for indoor use to reduce the potential for harmful interference to co-channel mobile satellite systems.

When using the 5GHz band: The device for operation in the band 5150-5250 MHz is only for indoor use to reduce the potential for harmful interference to co-channel mobile satellite systems.

High-power radars are allocated as primary users of the bands 5250-5350 MHz and 5650-5850 MHz and that these radars could cause interference and/or damage to Licence-Exempt Local Area Network devices.

INFORMATION DE CONFORMITÉ UE Le produit est conforme aux exigences des directives européennes EMC, R&TTE, ErP et RoHS. Voir: www.wacom.eu/certificates

CONFORMITÉ AVEC LES NORMES ENVIRONNEMENTALES

DEEE Réutilisation, recyclage et récupération. Une fois en fin de vie ou après son remplacement par un produit plus récent, il est fortement conseillé de recycler ce produit en le déposant dans un point de collecte de matériaux recyclables de votre région. Ce faisant, vous aidez à protéger l'environnement et minimisez les effets négatifs causés par d'éventuels écoulements de substances dangereuses lors de la mise au rebut. Au sein de l'Union Européenne, il est interdit aux utilisateurs de jeter les déchets d'équipements électriques et électroniques avec les ordures ménagères non triées, conformément à la Directive WEEE, ou aux lois équivalentes des États membres. Les produits concernés sont dotés du symbole WEEE illustré au début de cette remarque, sauf impossibilité due à la taille ou à la fonction du produit. Les produits Wacom sont soumis à la Directive WEEE et doivent donc être mis au rebut séparément, dans un point de collecte de votre région.

INFORMATIONS CONCERNANT LA MISE AU REBUT DES BATTERIES AU SEIN DE L'UNION EUROPEENNE

Remarque : ce symbole n'est utilisé que dans les pays de l'UE. Ce symbole est conforme à la directive 2006/66/CE Article 20. Informations pour l'utilisateur final et Annexe II. Votre produit a été conçu et fabriqué avec des composants et des matériaux de haute qualité qui peuvent être recyclés et/ou réutilisés. Ce symbole signifie que les batteries et les piles, lorsqu'elles sont usées, doivent être jetées séparément des déchets ménagers. Dans l'Union européenne, il existe des systèmes de collecte spéciaux pour les batteries et les piles usagées. Veuillez jeter correctement vos piles et vos batteries au centre de collecte ou de recyclage le plus proche. Merci de nous aider à protéger l'environnement dans lequel nous vivons !

Directiva ErP N'essayez pas de retirer, de réparer, de remplacer, de modifier ou d'accéder à la batterie de votre produit. Si vous avez un problème avec la batterie, veuillez contacter le service Support de Wacom de votre région.

INFORMAZIONI SULLO SMALTIMENTO E SUL RICICLAGGIO Riutilizzo, riciclaggio e recupero. In caso di sostituzione del presente prodotto con una versione più recente o al termine della durata di utilizzo del prodotto stesso, siete pregati di riciclarlo smaltendolo in un centro di raccolta per materiali riciclabili presente nel vostro comune o nella vostra regione. Così facendo, contribuirete al miglioramento dell'ambiente, riducendo al minimo i potenziali effetti negativi causati da sostanze pericolose che potrebbero essere presenti nei materiali di scarto e che potrebbero andare dispersi nell'ambiente durante il processo di smaltimento.

All'interno dell'Unione Europea, gli utenti non possono sfruttare i rifiuti di apparecchiature elettriche ed elettroniche come rifiuti comunali non differenziati, come indicato nella Direttiva WEEE, o dalla legislazione corrispondente nei singoli Stati Membri. I prodotti per cui è applicabile tale direttiva saranno contrassegnati con il simbolo WEEE, mostrato all'inizio della presente nota, fatta eccezione per i prodotti le cui dimensioni e/o funzioni non siano compatibili con suddetto simbolo. I prodotti Wacom sono soggetti alla Direttiva WEEE, e pertanto devono sempre essere smaltiti separatamente e portati in un centro di raccolta idoneo presente nel vostro comune o nella vostra regione.

INFORMAZIONI UE SULLO SMALTIMENTO DELLE BATTERIE Nota: questo marchio è valido solo per i Paesi UE ed è conforme alla direttiva 2006/66/CE Articolo 20. Informazioni per utenti finali è allegato II. Il prodotto è stato progettato e fabbricato con materiali e componenti di alta qualità, che possono essere riciclati e/o riutilizzati. Questo simbolo indica che le batterie e gli accumulatori, al termine della loro vita utile, devono essere smaltiti separatamente dai rifiuti domestici. In Unione Europea, vi sono sistemi di raccolta separata per batterie e accumulatori utilizzati. Smaltite batterie e accumulatori correttamente presso centri di riciclaggio/raccolta rifiuti locali. Aiutate a rispettare l'ambiente in cui viviamo!

Directiva ErP No intentes manipular, retirar, reparar, reemplazar ni alterar la batería del producto. Si tiene algún problema con la batería, póngase en contacto con el equipo técnico de Wacom de su región.

IT

DICHIARAZIONE DI LEGGE

INFORMAZIONI DI CONFORMITÀ UE Il prodotto corrisponde alle esigenze delle direttive europee EMC, R&TTE, ErP e RoHS. Vedi: www.wacom.eu/certificates



INFORMAZIONI SULLO SMALTIMENTO E SUL RICICLAGGIO

WEEE Riutilizzo, riciclaggio e recupero. In caso di sostituzione del presente prodotto con una versione più recente o al termine della durata di utilizzo del prodotto stesso, siete pregati di riciclarlo smaltendolo in un centro di raccolta per materiali riciclabili presente nel vostro comune o nella vostra regione. Così facendo, contribuirete al miglioramento dell'ambiente, riducendo al minimo i potenziali effetti negativi causati da sostanze pericolose che potrebbero essere presenti nei materiali di scarto e che potrebbero andare dispersi nell'ambiente durante il processo di smaltimento. All'interno dell'Unione Europea, gli utenti non possono sfruttare i rifiuti di apparecchiature elettriche ed elettroniche come rifiuti comunali non differenziati, come indicato nella Direttiva WEEE, o dalla legislazione corrispondente nei singoli Stati Membri. I prodotti per cui è applicabile tale direttiva saranno contrassegnati con il simbolo WEEE, mostrato all'inizio della presente nota, fatta eccezione per i prodotti le cui dimensioni e/o funzioni non siano compatibili con suddetto simbolo. I prodotti Wacom sono soggetti alla Direttiva WEEE, e pertanto devono sempre essere smaltiti separatamente e portati in un centro di raccolta idoneo presente nel vostro comune o nella vostra regione.

INFORMACION SOBRE ELIMINACION DE BATERIAS EN LA UE Nota: este símbolo solo es válido para países de la UE. El símbolo está conforme con el artículo 20 (Información para usuarios finales) y el anexo II de la Directiva 2006/66/CE. El producto ha sido diseñado y fabricado con materiales y componentes de alta calidad que pueden ser reciclados o reutilizados. Este símbolo indica que las pilas y acumuladores no deben ser eliminados junto con la basura doméstica al finalizar su vida útil. La Unión Europea cuenta con sistemas de recogida selectiva de pilas y acumuladores usados. Elimine debidamente las pilas y acumuladores en un centro de reciclaje/recogida de residuos de su municipio. ¡Ayúdenos a conservar el medio ambiente en el que vivimos!

Directiva ErP No intentes manipular, retirar, reparar, reemplazar ni alterar la batería del producto. Si tiene algún problema con la batería, póngase en contacto con el equipo técnico de Wacom de su región.

ES

DECLARACIONES REGLAMENTARIAS

INFORMACION DE CONFORMIDAD UE El producto corresponde a las exigencias de las directivas europeas EMC, R&TTE, ErP y RoHS. Véase: www.wacom.eu/certificates



CONFORMIDAD MEDIOAMBIENTAL

WEEE Reutilización, reciclado y recuperación. Le recomendamos que recycle este producto cuando lo sustituya por uno nuevo o cuando haya pasado su período de vida útil. Para ello, lleve-lo a un punto de recogida de materiales para reciclar de su localidad o comarca. Al hacerlo, ayudará a mejorar el medioambiente de su localidad, así como a reducir los posibles efectos negativos que se produzcan por cualquier sustancia presente en los materiales de desecho que entre en contacto con el medioambiente durante el proceso de eliminación. En la Unión Europea, los usuarios no deben desechar equipos electrónicos y eléctricos como un vertido municipal, según lo estipulado en la directiva WEEE, o en las leyes locales correspondientes de cada estado miembro. Los productos a los que se les aplica esta instrucción están marcados con el símbolo WEEE que aparece al principio de esta nota, a menos que no sea posible por el tamaño o la función del producto. Los productos Wacom están sujetos a la directiva WEEE y, por tanto, deberá separarlos y llevarlos al punto de recogida adecuado de su localidad o provincia.

INFORMACION SOBRE ELIMINACION DE BATERIAS EN LA UE Nota: este símbolo solo es válido para países de la UE. El símbolo está conforme con el artículo 20 (Información para usuarios finales) y el anexo II de la Directiva 2006/66/CE. El producto ha sido diseñado y fabricado con materiales y componentes de alta calidad que pueden ser reciclados o reutilizados. Este símbolo indica que las pilas y acumuladores no deben ser eliminados junto con la basura doméstica al finalizar su vida útil. La Unión Europea cuenta con sistemas de recogida selectiva de pilas y acumuladores usados. Elimine debidamente las pilas y acumuladores en un centro de reciclaje/recogida de residuos de su municipio. ¡Ayúdenos a conservar el medio ambiente en el que vivimos!

Directiva ErP No intentes manipular, retirar, reparar, reemplazar ni alterar la batería del producto. Si tiene algún problema con la batería, póngase en contacto con el equipo técnico de Wacom de su región.



REGULATORY STATEMENT

INFORMAÇÕES SOBRE CONFORMIDADE COM A UE
 O produto está em conformidade com as Diretivas Europeias EMC, R&TTE, ErP,e RoHS.
 Consulte: www.wacom.eu/certificates



Diretiva de descarte de equipamentos elétricos e eletrônicos (WEEE)

Na União Europeia, esta etiqueta indica que este produto não deve ser descartado com o lixo comum. Os produtos da Wacom estão sujeitos à esta Diretiva e devem ser sempre coletados separadamente e levados ao ponto de coleta apropriado em em sua comunidade ou região para recuperação e reciclagem. Consulte as informações de sua comunidade para obter informações sobre como reciclar resíduos eletrônicos com responsabilidade em sua região.

INFORMATIONEN DER EU ZUR ENTSORGUNG VON BATTERIEN

Hinweis: Dieses Symbol gilt nur für EU-Staaten.
 Dieses Symbol wird gemas der Richtlinie 2006/66/EG Artikel 20.
 Informationen für Endverbraucher, Anhang II, verwendet.
 Dieses Produkt wurde unter Verwendung hochwertiger Materialien und Bestandteile entwickelt und hergestellt, die recycelt und/oder wiederverwendet werden können. Dieses Symbol besagt, dass Batterien und Akkus nach ihrem Lebenszyklus nicht im Hausmüll entsorgt werden dürfen.
 In der Europäischen Union gibt es unterschiedliche Sammelsysteme für gebrauchte Batterien und Akkus. Bitte entsorgen Sie Batterien und Akkus vorschriftsmäßig bei Ihrer kommunalen Sammel-/Recyclingstelle.
 Bitte unterstützen Sie uns bei der Erhaltung unserer Umwelt!
 Entsorgung der eingebauten Lithium-Ionen-Batterie
 Bitte kontaktieren Sie den Wacom Support bezüglich der Entsorgung der eingebauten Lithium-Ionen-Batterie.



Turkey RoHS
 Türkiye Cumhuriyeti: EEE Yönetmeliğine Uygundur



電波障害自主規制等について

この装置は、クラス B 情報装置です。この装置は、家庭環境で使用されていることを目的としていますが、この装置がラジオやテレビジョン受信機に近接して使用されると、受信障害を起こすことがあります。
 取扱説明書にしたがって正しい取り扱いをしてください。



ENERGY STAR® 準拠
 コンピュータのための ENERGY STAR プログラムは、米国 EPA (環境保護庁) によって策定され、家庭、オフィス、および工場で、よりエネルギー効率の高い機器を使用することによって、エネルギー効率を促進し、大気汚染を削減することを目的としています。製品がこの目的を実現する 1 つの方法が、Microsoft® Windows® のパワーマネジメント機能を使用した、製品非使用時の消費電力の削減です。

コンピュータは、電源 / スリープボタンを押すと、スリープから復帰します。Wake On LAN (WOL) 機能が有効な場合、ネットワーク信号によってコンピュータをスリープから復帰させることもできます。

当社は国際エネルギースタープログラムの参加事業者として、本製品が国際エネルギースタープログラムの基準に適合していると判断します。



本製品はエネルギースター規格に基づいて設計されており、AC 電源に接続してご使用の場合には次の省電力設定で出荷されています。
 ・何も操作をしないと 15 分以内に自動的に液晶ディスプレイの電源を切る。
 ・何も操作をしないと 30 分以内に自動的にスリープモードまたはスタンバイに移行する。

電波法規制
 本機は電波法に基づく小電力データ通信システム無線局設備として技術基準適合証明を受けた無線装置を内蔵しています。従って、本機を使用するときに無線局の免許は必要ありません。
 日本国内のみで使用してください。各国の電波法に抵触する可能性があります。
 また、本機に内蔵している無線装置は、電気通信事業法に基づく技術基準適合証明を受けていますので、以下の事項を行うと、法律で罰せられることがあります。
 ・分割 / 改造されていること
 ・貼つてある証明ラベルをはがすこと

電波法 (RF) 規制
 日本国内で本製品をご使用になる場合のお問い合わせの機器の使用周波数帯では、電子レンジ等の産業、科学、医療用機器のほか工場の高圧ライン等で使用されている移動体識別用の構内無線局 (免許を要する無線局) 及び特定小電力無線局 (免許を要しない無線局) 並びにアマチュア無線局 (免許を要する無線局) が運用されています。

1. この機器を使用する前に、近くで移動体識別用の構内無線局及び特定小電力無線局並びにアマチュア無線局が運用されていないことを確認して下さい。
 2. 万一、この機器から移動体識別用の構内無線局に対して有害な電波干渉の事例が発生した場合には、速やかに使用周波数を変更するか又は電波の発射を停止した上、サポート窓口にご連絡頂き、返信返信のための処置等 (例えば、パーティションの設置など) についてご相談して下さい。
 3. その他、この機器から移動体識別用の特定小電力無線局あるいはアマチュア無線局に対して有害な電波干渉の事例が発生した場合など何かお困りのことが起きたときは、サポート窓口へお問い合わせ下さい。

リチウムイオン電池の回収について
 本体に内蔵されているリチウムイオン電池は、取り外すことができます。本体と一緒に回収しますので、そのままリサイクルにお申し込みください。本体のリサイクルについては、「液晶ペンタブレットのリサイクルについて」をご覧ください。

液晶ペンタブレットのリサイクルについて
 資源有効利用促進法の施行により、工場では工場製の使用済み液晶ペンタブレットの回収 / リサイクル活動を行っています。液晶ペンタブレットのリサイクルのお問い合わせについては、以下のインターネットアドレスをご参照ください。
<http://tablet.wacom.co.jp/customer-care/recycle/>



TC
 產品名稱: Graphics tablet computer 型號: DTH-W1320 / DTH-W1620

低功率電波輻射性電機管理辦法
 第12條 經型式認證合格之低功率射頻電機，非經許可，公司、商號或使用者均不得擅自變更頻率、加大功率或變更原設計之特性及功能。
 第14條 低功率射頻電機之使用不得影響飛航安全及干擾合法通信；經發現有干擾現象時，應立即停用，並改善至無干擾時方得繼續使用。
 前項合法通信，指依電信法規定作業之無線電通信。低功率射頻電機須忍受合法通信或工業、科學及醫療用電波輻射性電機設備之干擾。



台灣廢棄物處理方法
 台灣電池通告
 台灣環保署要求遵守廢棄物處理法令第15條的乾電池製造或進口公司在用於銷售、廢品或從廢的電用上用回收標誌作標示。
 廢電池回收標誌 請聯絡有資格的台灣回收公司進行妥善的電池處理。
 請回收利用使用後的電池

台灣危害物質限制指令 (RoHS) 資訊
 各產品限用有害物質 (RoHS) 含有情況標示於官方網站
 請見 <http://www.wacom.com/dth-tw/support/certificates>

低功率標語
 (主要針對支援 BT/WiFi/NFC 功能的產品)
 經型式認證合格之低功率射頻電機，非經許可，公司、商號或使用者均不得擅自變更頻率、加大功率或變更原設計之特性及功能。
 低功率射頻電機之使用不得影響飛航安全及干擾合法通信；經發現有干擾現象時，應立即停用，並改善至無干擾時方得繼續使用。
 前項合法通信，指依電信法規定作業之無線電通信。低功率射頻電機須忍受合法通信或工業、科學及醫療用電波輻射性電機設備之干擾。

限於室內使用標語
 (適用於產品支援 5G band 11)
 在 5.25-5.35 赫赫頻帶內操作之無線資訊傳輸設備，限於室內使用。

使用過度恐傷害視力 使用30分鐘請休息10分鐘 未滿2歲幼兒不看螢幕，2歲以上每天看螢幕不要超過1小時



KC RF 靜音等相關 機能
 해당 무선설비는 운용 중 전파혼신 가능성이 있으므로 인명안전과 관련된 서비스를 할 수 없음
 해당 무선설비는 전파혼신 가능성이 있으므로 인명안전과 관련된 서비스는 할 수 없음
 무선 기기에 대한 노출 기준은 전차파 인체 흡수율 또는 SAR 이라고 알려진 측정 단위를 사용합니다. RRA 에서 정한 SAR 한도는 1.6W/kg 입니다.
 RF 노출 요구사항을 준수하기 위해 신체에 착용할 상태로 설명 시 사용자의 신체와 안테나를 포함 한 기기 간에는 최소 이격 거리인 1.5cm 가 유지되어야 합니다.



SC
 符合中国国家标准
 GB4943.1-2011; GB17625.1-2012; GB9254-2008; GB28380-2012

产品中有害物质的名称及含量

部件名称	有害物質					
	鉛 (Pb)	汞 (Hg)	鎘 (Cd)	六价鉻 (Cr (VI))	多溴联苯 (PBB)	多溴二苯醚 (PBDE)
基板	X	0	0	0	0	0
外壳	0	0	0	0	0	0
金属件	X	0	0	0	0	0
连接线	0	0	0	0	0	0
防护板	0	0	0	0	0	0
笔座/笔盒	0	0	0	0	0	0
说明书	0	0	0	0	0	0
触控笔	X	0	0	0	0	0
电池	X	0	0	0	0	0

本表格依据SJ/T 11364的规定编制。
 O: 表示该有害物质在该部件所有均质材料中的含量均在GB/T 26572规定的限量要求以下。
 X: 表示该有害物质至少在该部件的某一均质材料中的含量超出GB/T 26572规定的限量要求。

和冠科技 (北京) 有限公司
 中国北京市朝阳区建国门外大街1号中国国际贸易中心
 国贸西楼518室; 邮编: 100004

RF Module: Regulatory Certification ID No.

Certification ID No.	Country
TEL: D140017003 RF: 003-140018	Japan
-	Australia and New Zealand
BN: PD-2777	Russia
BN: RCPIN7214-0331	Mexico
ER0128120/14	United Arab Emirates



© 2016 Wacom Co., Ltd. All rights reserved.
 Wacom, MobileStudio and their respective logos are trademarks and/or registered trademarks of Wacom Co., Ltd.