



FCC TEST REPORT

FCC ID : HV4DTC133
Equipment : CREATIVE PEN DISPLAY
Brand Name : WACOM
Model Name : DTC133 , DTC133W0A
Applicant/ : Wacom Co., Ltd.
Manufacturer : 2-510-1, Toyonodai, Kazo-shi, Saitama, 349-1148 Japan
Standard : 47 CFR FCC Part 15.209

The product was received on Oct. 16, 2019, and testing was started from Oct. 21, 2019 and completed on Oct. 25, 2019. We, SPORTON INTERNATIONAL INC. EMC & Wireless Communications Laboratory, would like to declare that the tested sample has been evaluated in accordance with the procedures given in ANSI C63.10-2013 and shown compliance with the applicable technical standards.

The report must not be used by the client to claim product certification, approval, or endorsement by TAF or any agency of government.

The test results in this report apply exclusively to the tested model / sample. Without written approval of SPORTON INTERNATIONAL INC. EMC & Wireless Communications Laboratory, the test report shall not be reproduced except in full.

Approved by: Allen Lin

SPORTON INTERNATIONAL INC. EMC & Wireless Communications Laboratory

No. 52, Huaya 1st Rd., Guishan Dist., Taoyuan City, Taiwan (R.O.C.)



Table of Contents

- 1 GENERAL DESCRIPTION5**
- 1.1 Information.....5
- 1.2 Testing Applied Standards6
- 1.3 Testing Location Information6
- 1.4 Measurement Uncertainty7
- 2 TEST CONFIGURATION OF EUT.....8**
- 2.1 The Worst Case Modulation Configuration8
- 2.2 Test Channel Frequencies Configuration.....8
- 2.3 The Worst Case Measurement Configuration8
- 2.4 Accessory and Support Equipment9
- 2.5 Test Setup Diagram10
- 3 TRANSMITTER TEST RESULT12**
- 3.1 AC Power-line Conducted Emissions12
- 3.2 Transmitter Radiated Emissions16
- 3.3 Emission Bandwidth24
- 4 TEST EQUIPMENT AND CALIBRATION DATA.....27**

Appendix A. Test Photos

Photographs of EUT v01



History of this test report

Report No.	Version	Description	Issued Date
FR9O0430AS	01	Initial issue of report	Nov. 12, 2019



Summary of Test Result

Report Clause	Ref Std. Clause	Test Items	Result (PASS/FAIL)	Remark
1.1.2	15.203	Antenna Requirement	PASS	-
3.1	15.207	AC Power-line Conducted Emissions	PASS	-
3.2	15.209	Transmitter Radiated Emissions	PASS	-
3.3	15.215(c)	Emission Bandwidth	PASS	-

Declaration of Conformity:
The test results with all measurement uncertainty excluded are presented in accordance with the regulation limits or requirements declared by manufacturers.
Comments and Explanations:
None.

Reviewed by: Sam Tsai

Report Producer: Kate Lo

1 General Description

1.1 Information

1.1.1 RF General Information

RF General Information			
Frequency		531.25kHz~625kHz	
Modulation	Ch. Frequency (kHz)	Channel Number	Field Strength (dBuV/m)
ASK	531.25/562.5/593.75/625	4	56.31
Note 1: Field strength performed peak level at 1m.			

1.1.2 Antenna Information

Antenna Category	
<input checked="" type="checkbox"/>	Integral antenna (antenna permanently attached)
<input type="checkbox"/>	Temporary RF connector provided
<input checked="" type="checkbox"/>	No temporary RF connector provided Transmit chains bypass antenna and soldered temporary RF connector provided for connected measurement. In case of conducted measurements the transmitter shall be connected to the measuring equipment via a suitable attenuator and correct for all losses in the RF path.
<input type="checkbox"/>	External antenna (dedicated antennas)
<input type="checkbox"/>	Single power level with corresponding antenna(s).
<input type="checkbox"/>	Multiple power level and corresponding antenna(s).

No.	Ant. Cat.	Ant. Type
1	Integral	Array Coil Pointing

1.1.3 Type of EUT

Type of EUT	
<input checked="" type="checkbox"/>	Stand-alone
<input type="checkbox"/>	Combined (EUT where the radio part is fully integrated within another device)
	Combined Equipment - Brand Name / Model No.: ...
<input type="checkbox"/>	Plug-in radio (EUT intended for a variety of host systems)
	Host System - Brand Name / Model No.: ...
<input type="checkbox"/>	Other:

1.1.4 Test Signal Duty Cycle

Operated Mode for Worst Duty Cycle	
<input checked="" type="checkbox"/>	Operated normal mode for worst duty cycle
<input type="checkbox"/>	Operated test mode for worst duty cycle
Test Signal Duty Cycle (x)	
<input checked="" type="checkbox"/>	100.00%

1.1.5 EUT Operational Condition

Supply Voltage	<input checked="" type="checkbox"/> AC mains	<input checked="" type="checkbox"/> DC	
Type of DC Source	<input checked="" type="checkbox"/> External AC adapter	<input checked="" type="checkbox"/> From Host System	<input type="checkbox"/> From Battery

1.1.6 Table for Multiple Listing

The model names in the following table are all refer to the identical product.

Model Name	Description
DTC133	All the models are identical, the difference model served as marketing strategy.
DTC133W0A	

1.2 Testing Applied Standards

According to the specifications of the manufacturer, the EUT must comply with the requirements of the following standards:

- 47 CFR FCC Part 15
- ANSI C63.10-2013

1.3 Testing Location Information

Testing Location		
<input checked="" type="checkbox"/>	HWA YA	ADD : No. 52, Huaya 1st Rd., Guishan Dist., Taoyuan City, Taiwan (R.O.C.) TEL : 886-3-327-3456 FAX : 886-3-327-0973
Test site Designation No. TW1190 with FCC.		
<input type="checkbox"/>	JHUBEI	ADD : No.8, Ln. 724, Bo'ai St., Zhubei City, Hsinchu County, Taiwan (R.O.C.) TEL : 886-3-656-9065 FAX : 886-3-656-9085
Test site Designation No. TW0006 with FCC.		

Test Condition	Test Site No.	Test Engineer	Test Environment	Test Date
AC Conduction	CO04-HY	Jeff	21.5~23.1°C / 58.4~62.2%	23/Oct/2019
RF Conducted	TH01-HY	Andy	23.5~25.9°C / 62.5~65.7%	21/Oct/2019
Radiated Emission	03CH03-HY	Terry	24.7~25.1°C / 57.8~58.2%	25/Oct/2019



1.4 Measurement Uncertainty

ISO/IEC 17025 requires that an estimate of the measurement uncertainties associated with the emissions test results be included in the report. The measurement uncertainties given below are based on a 95% confidence level (based on a coverage factor (k=2))

Test Items	Uncertainty	Remark
Conducted Emission (150kHz ~ 30MHz)	3.54 dB	Confidence levels of 95%
Radiated Emission (9kHz ~ 30MHz)	1.6 dB	Confidence levels of 95%
Radiated Emission (30MHz ~ 1,000MHz)	4.3 dB	Confidence levels of 95%
Radiated Emission (1GHz ~ 18GHz)	3.9 dB	Confidence levels of 95%
Radiated Emission (18GHz ~ 40GHz)	3.5 dB	Confidence levels of 95%
Conducted Emission	1.3 dB	Confidence levels of 95%
Temperature	0.7 °C	Confidence levels of 95%
Humidity	4 %	Confidence levels of 95%

2 Test Configuration of EUT

2.1 The Worst Case Modulation Configuration



Transmitter Mode	Field Strength (dBuV/m@1m)	Field Strength (dBuV/m@3m)
Touch Panel	56.31	37.23

2.2 Test Channel Frequencies Configuration

Modulation	Test Channel Frequencies (kHz)
ASK	562.5

2.3 The Worst Case Measurement Configuration

The Worst Case Mode for Following Conformance Tests	
Tests Item	AC power-line conducted emissions
Condition	AC power-line conducted measurement for line and neutral
Operating Mode	CTX
1	Adapter Mode

The Worst Case Mode for Following Conformance Tests			
Tests Item	Emission Bandwidth, Field Strength of Fundamental Emissions Transmitter Radiated Unwanted Emissions		
Test Condition	Radiated measurement		
User Position	<input type="checkbox"/> EUT will be placed in fixed position.		
	<input type="checkbox"/> EUT will be placed in mobile position and operating multiple positions. EUT shall be performed three orthogonal planes.		
	<input checked="" type="checkbox"/> EUT will be a hand-held or body-worn battery-powered devices and operating multiple positions.		
Operating Mode	CTX		
1	Adapter Mode		
Orthogonal Planes of EUT	X Plane	Y Plane	Z Plane
			
Worst Planes of EUT			V



2.4 Accessory and Support Equipment

Accessories Information				
AC Adapter	Brand Name	APD	Model Name	WB-10E05R
	Power Rating	I/P: 100 - 240Vac, 0.4A, O/P: 5Vdc, 2A		
Digital Pen	Brand Name	Wacom	Model Name	CP-913-00B-2
USB Type-C Cable	Brand Name	ACON	Model Name	C-J142-00-00-A
	Power Cord	1.78 meter, shielded cable, w/o ferrite core		

Note: Regarding to more detail and other information, please refer to user manual.

Support Equipment - RF Conducted			
No.	Equipment	Brand Name	Model Name
1	Notebook	DELL	E5410
2	Adapter for NB	DELL	HA65NM130
3	DC Power Supply	GW	GPS-3030DD

Support Equipment - RF Radiated Emission			
No.	Equipment	Brand Name	Model Name
1	Notebook	DELL	E4300
2	Adapter for NB	DELL	AA90PM111

2.5 Test Setup Diagram

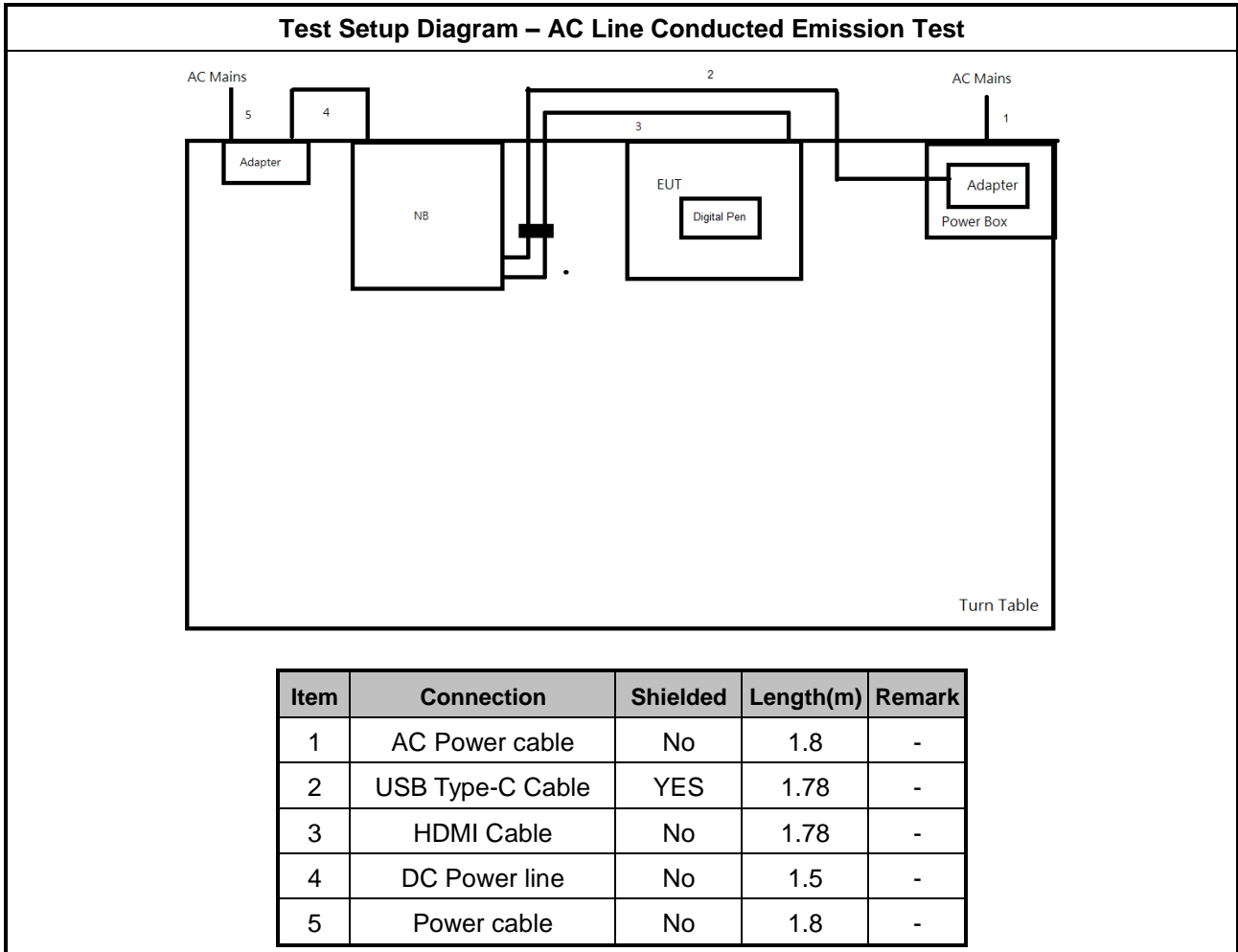

Test Setup Diagram - Radiated Test

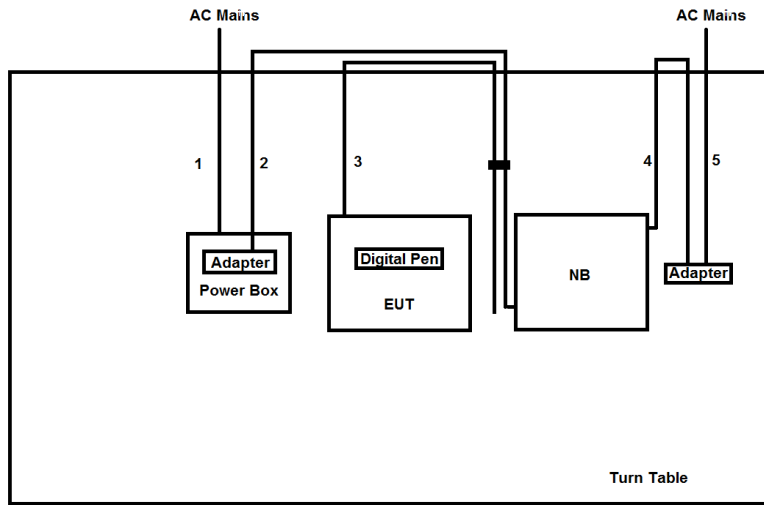

Item	Connection	Shielded	Length(m)	Remark
1	Power cable	No	1.8	-
2	USB Type-C Cable	YES	1.78	-
3	HDMI Cable	No	1.78	-
4	DC Power line	No	1.5	-
5	Power cable	No	1.8	-

3 Transmitter Test Result

3.1 AC Power-line Conducted Emissions

3.1.1 AC Power-line Conducted Emissions Limit

AC Power-line Conducted Emissions Limit		
Frequency Emission (MHz)	Quasi-Peak	Average
0.15-0.5	66 - 56 *	56 - 46 *
0.5-5	56	46
5-30	60	50

Note 1: * Decreases with the logarithm of the frequency.

3.1.2 Measuring Instruments

Refer a test equipment and calibration data table in this test report.

3.1.3 Test Procedures

Test Method	
<input checked="" type="checkbox"/>	Refer as ANSI C63.10-2013, clause 6.2 for AC power-line conducted emissions.
<input checked="" type="checkbox"/>	If AC conducted emissions fall in operating band, then following below test method confirm final result.
<input type="checkbox"/>	Accept measurements done with a suitable dummy load replacing the antenna under the following conditions: (1) Perform the AC line conducted tests with the antenna connected to determine compliance with FCC 15.207 limits outside the transmitter's fundamental emission band; (2) Retest with a dummy load to determine compliance with FCC 15.207 limits within the transmitter's fundamental emission band.
<input checked="" type="checkbox"/>	For a device with a permanent antenna operating at or below 30 MHz, accept measurements done with a suitable dummy load, in lieu of the permanent antenna under the following conditions: (1) Perform the AC line conducted tests with the permanent antenna to determine compliance with the FCC 15.207 limits outside the transmitter's fundamental emission band; (2) Retest with a dummy load in lieu of the permanent antenna to determine compliance with the FCC 15.207 limits within the transmitter's fundamental emission band.

3.1.4 Test Setup

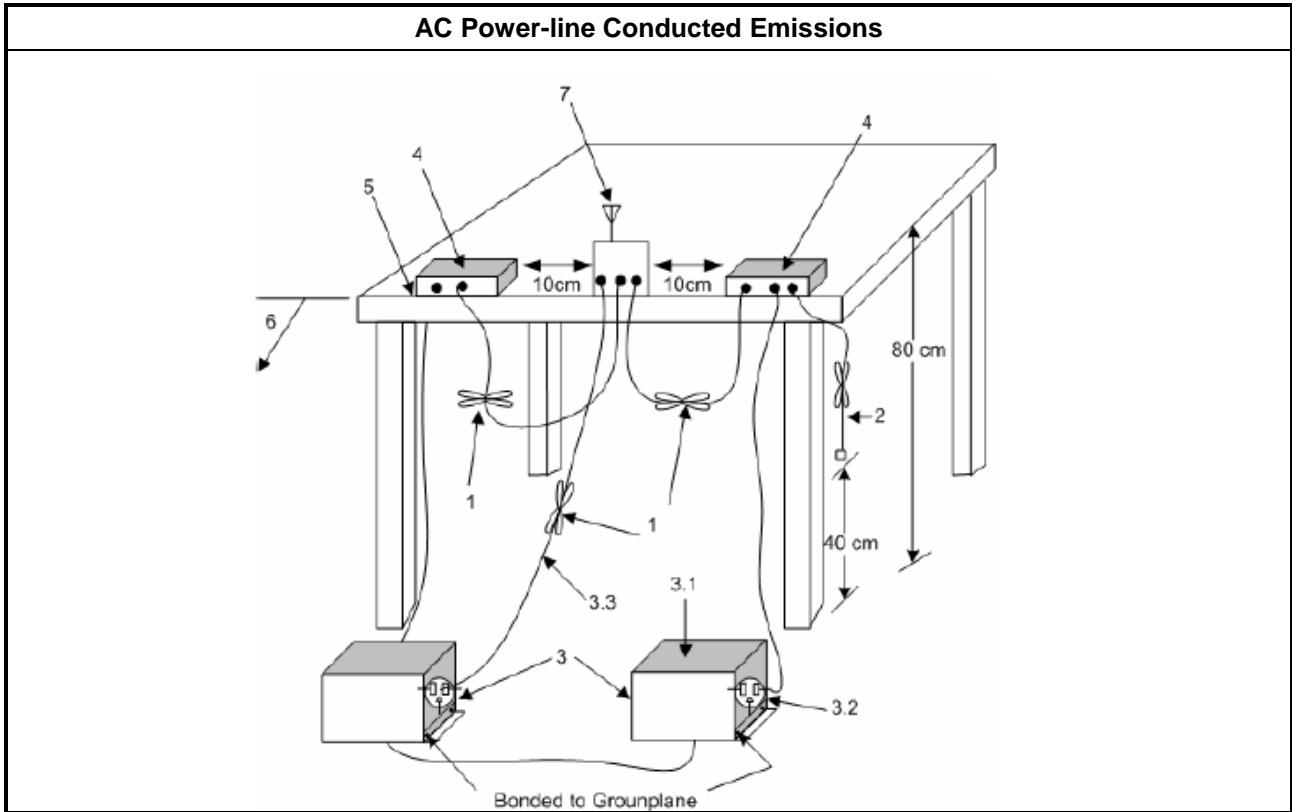

3.1.5 Test Result of AC Power-line Conducted Emissions

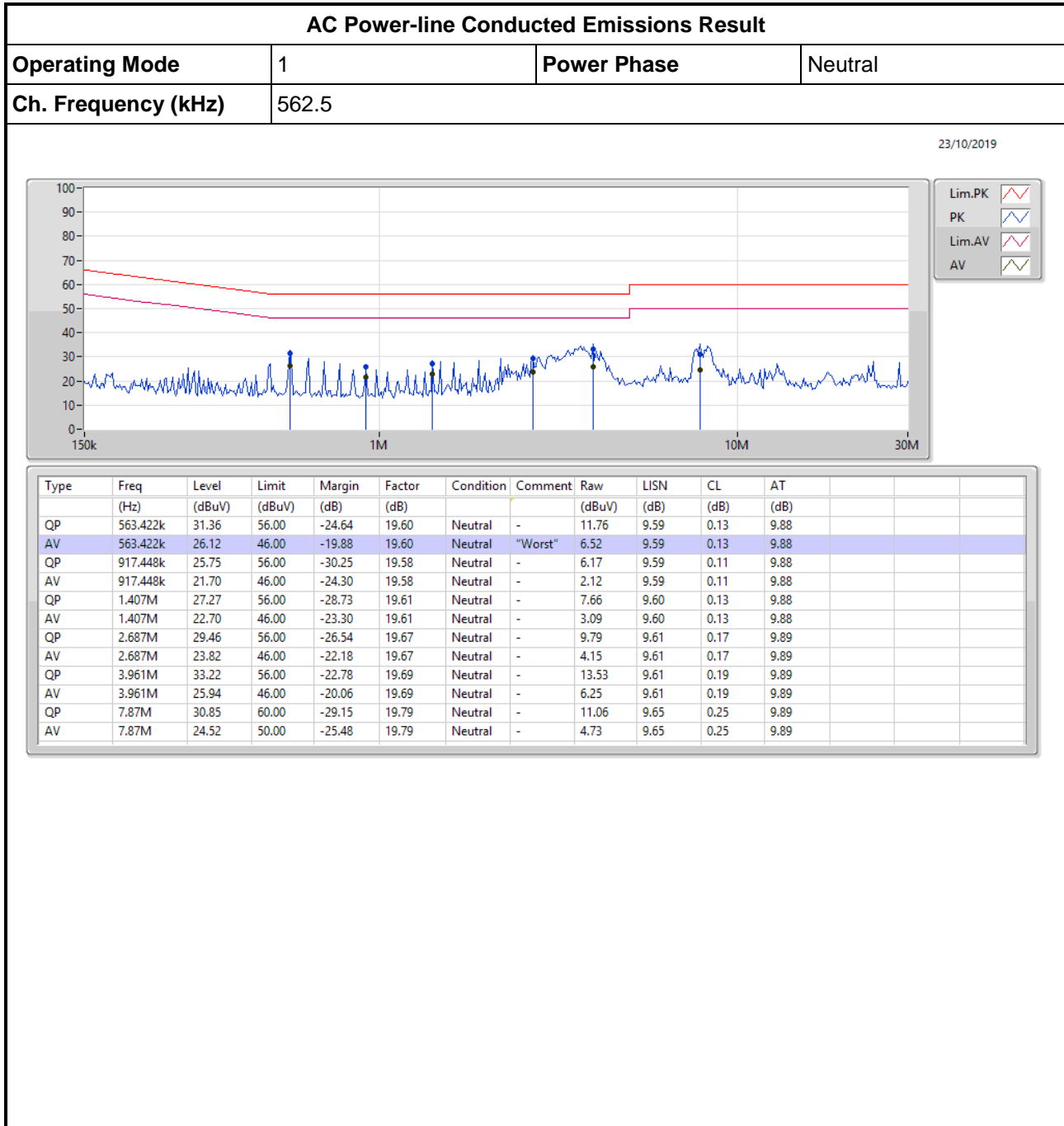



AC Power-line Conducted Emissions Result

Operating Mode	1	Power Phase	Line
Ch. Frequency (kHz)	562.5		

23/10/2019

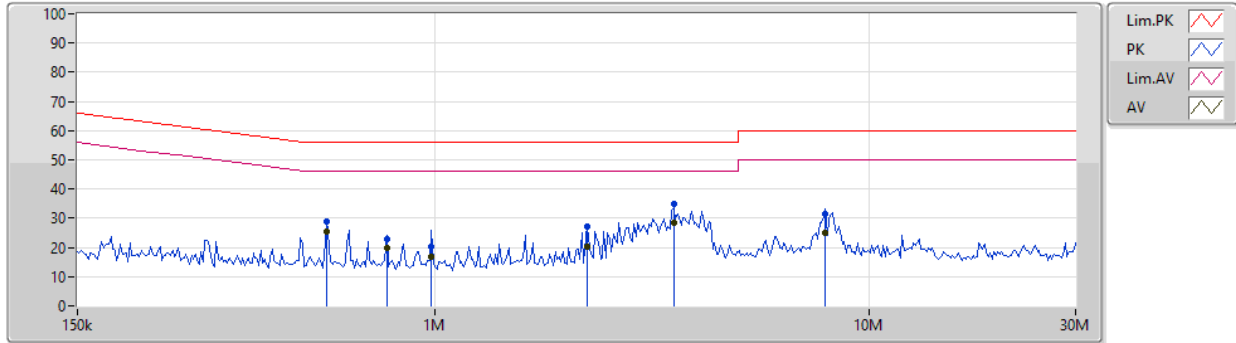

Type	Freq (Hz)	Level (dBuV)	Limit (dBuV)	Margin (dB)	Factor (dB)	Condition	Comment	Raw (dBuV)	LISN (dB)	CL (dB)	AT (dB)
QP	563.422k	29.04	56.00	-26.96	19.60	Line	-	9.44	9.59	0.13	9.88
AV	563.422k	25.49	46.00	-20.51	19.60	Line	-	5.89	9.59	0.13	9.88
QP	774.672k	22.99	56.00	-33.01	19.60	Line	-	3.39	9.60	0.12	9.88
AV	774.672k	19.70	46.00	-26.30	19.60	Line	-	0.10	9.60	0.12	9.88
QP	983.628k	20.18	56.00	-35.82	19.59	Line	-	0.59	9.60	0.11	9.88
AV	983.628k	16.92	46.00	-29.08	19.59	Line	-	-2.67	9.60	0.11	9.88
QP	2.246M	27.32	56.00	-28.68	19.67	Line	-	7.65	9.62	0.16	9.89
AV	2.246M	20.27	46.00	-25.73	19.67	Line	-	0.60	9.62	0.16	9.89
QP	3.55M	34.87	56.00	-21.13	19.70	Line	-	15.17	9.63	0.18	9.89
AV	3.55M	28.37	46.00	-17.63	19.70	Line	"Worst"	8.67	9.63	0.18	9.89
QP	7.949M	31.54	60.00	-28.46	19.80	Line	-	11.74	9.66	0.25	9.89
AV	7.949M	25.09	50.00	-24.91	19.80	Line	-	5.29	9.66	0.25	9.89



3.2 Transmitter Radiated Emissions

3.2.1 Transmitter Radiated Emissions Limit

Transmitter Radiated Emissions Limit			
Frequency Range (MHz)	Field Strength (uV/m)	Field Strength (dBuV/m)	Measure Distance (m)
0.009~0.490	2400/F(kHz)	48.5 - 13.8	300
0.490~1.705	24000/F(kHz)	33.8 - 23	30
1.705~30.0	30	29	30
30~88	100	40	3
88~216	150	43.5	3
216~960	200	46	3
Above 960	500	54	3

Note 1: Test distance for frequencies at or above 30 MHz, measurements may be performed at a distance other than the limit distance provided they are not performed in the near field and the emissions to be measured can be detected by the measurement equipment. When performing measurements at a distance other than that specified, the results shall be extrapolated to the specified distance using an extrapolation factor of 20 dB/decade (inverse of linear distance for field-strength measurements, inverse of linear distance-squared for power-density measurements).

Note 2: Test distance for frequencies at below 30 MHz, measurements may be performed at a distance closer than the EUT limit distance; however, an attempt should be made to avoid making measurements in the near field. When performing measurements below 30 MHz at a closer distance than the limit distance, the results shall be extrapolated to the specified distance by either making measurements at a minimum of two or more distances on at least one radial to determine the proper extrapolation factor or by using the square of an inverse linear distance extrapolation factor (40 dB/decade). The test report shall specify the extrapolation method used to determine compliance of the EUT.

Note 3: the frequency bands 9-90 kHz, 110-490 kHz measurements employing an average detector and other below 1GHz measurements employing a CISPR quasi-peak detector.

3.2.2 Measuring Instruments

Refer a test equipment and calibration data table in this test report.



3.2.3 Test Procedures

Test Method	
<input checked="" type="checkbox"/>	Refer as ANSI C63.10, clause 6.5 for radiated emissions from 30 MHz to 1 GHz and test distance is 3m. Note : The test distance of radiated emissions from 662kHz to 672kHz is 1m.
<input checked="" type="checkbox"/>	Refer as ANSI C63.10, clause 6.4 for radiated emissions from below 30 MHz. The frequency bands 9-90 kHz, 110-490 kHz measurements employing an average detector and other below 30MHz measurements employing a CISPR quasi-peak detector. Test distance is 3m.
<input checked="" type="checkbox"/>	At frequencies below 30 MHz, measurements may be performed at a distance closer than that specified in the requirements; however, an attempt should be made to avoid making measurements in the near field. Pending the development of an appropriate measurement procedure for measurements performed below 30 MHz, when performing measurements at a closer distance than specified, the results shall be following below methods. Note: If fundamental emission level is smaller than noise at 3m , we will change distance to 1m.
<input type="checkbox"/>	The results shall be extrapolated to the specified distance by making measurements at a minimum of two distances on at least one radial to determine the proper extrapolation factor.
<input checked="" type="checkbox"/>	The results shall be by using the square of an inverse linear distance extrapolation factor (40 dB/decade).
<input checked="" type="checkbox"/>	For radiated measurement. Loop antenna was rotated about the horizontal and vertical axis and the equipment to be measured and the test antenna shall be oriented to obtain the maximum emitted field strength level.
<input checked="" type="checkbox"/>	The any unwanted emissions level shall not exceed the fundamental emission level.
<input checked="" type="checkbox"/>	All amplitude of spurious emissions that are attenuated by more than 20 dB below the permissible value has no need to be reported.

3.2.4 Test Setup

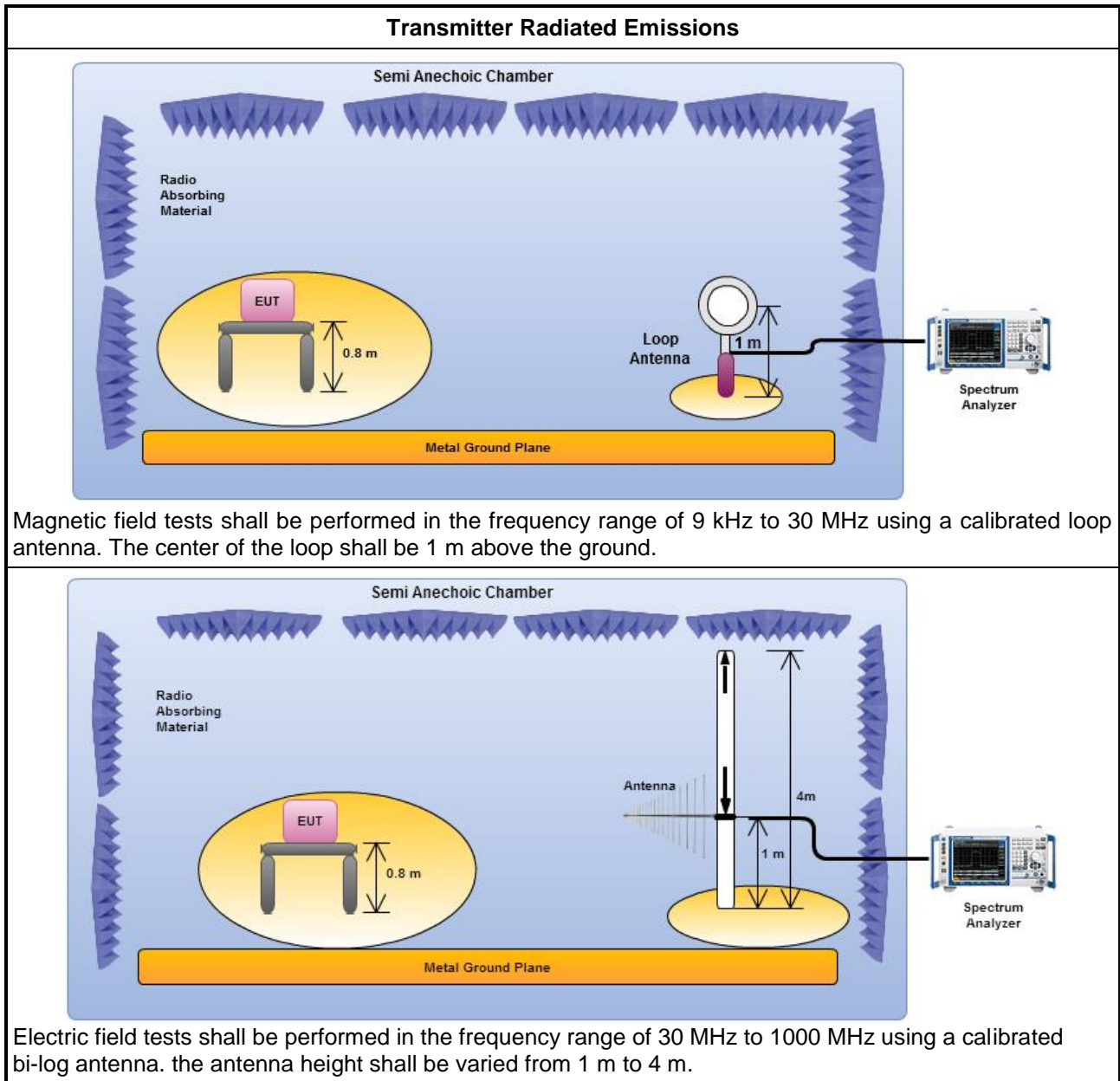



3.2.5 Transmitter Radiated Emissions (Below 30MHz)

Transmitter Radiated Emissions (Fundamental Emission)			
Mode	Touch Panel	Test Freq.(kHz)	562.5
Operating Mode	1	Polarization	H

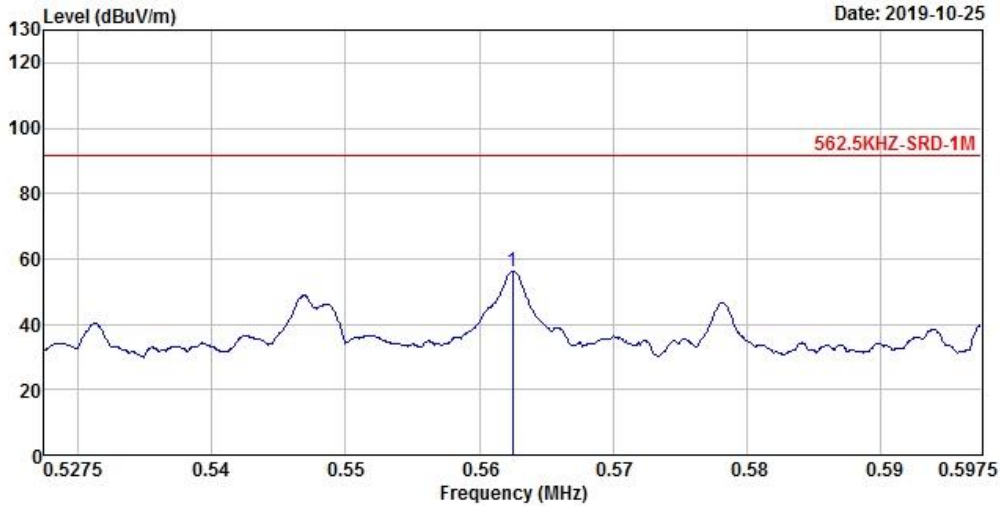

1 M	0.56	56.31	-35.38	91.69	36.20	19.92	0.19	0.00	0	100	Peak
-----	------	-------	--------	-------	-------	-------	------	------	---	-----	------

Note 1: ">20dB" means spurious emission levels that exceed the level of 6 dB below the applicable limit.
 Note 2: "N/F" means Nothing Found spurious emissions (No spurious emissions were detected.)
 Note 3: Measurement worst emissions of receive antenna polarization: H (Horizontal).
 Note 4: No level of unwanted emissions exceeds the level of the fundamental emission.
 Note 5: Test fundamental emission at 1m.
 Note 6: Below 30MHz of spurious emissions that are attenuated by more than 20 dB below the permissible value has no need to be reported.



Transmitter Radiated Emissions (9kHz~150kHz)

Mode	Touch Panel	Test Freq.(kHz)	562.5
Operating Mode	1	Polarization	H

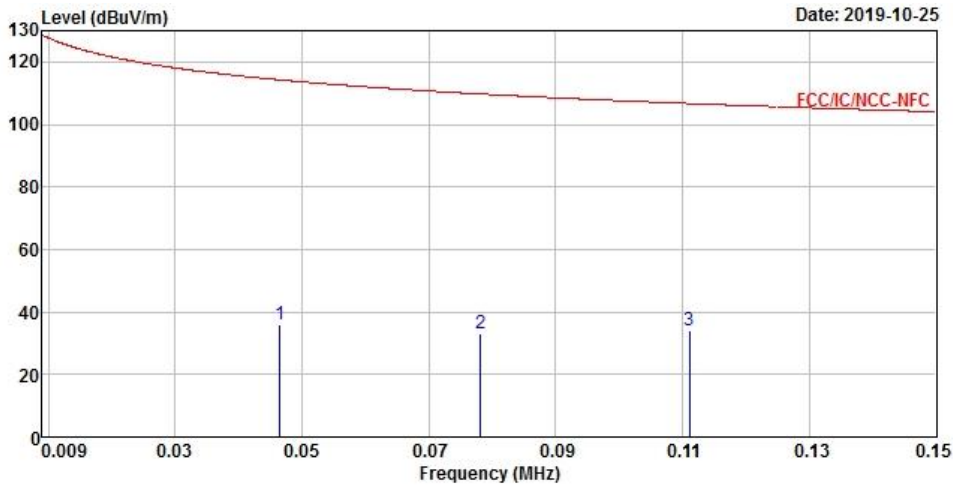

	Freq	Level	Over Limit	Limit Line	ReadAntenna Level	Cable Factor	Preamp Loss	A/Pos	T/Pos	Remark
	MHz	dBuV/m	dB	dBuV/m	dBuV	dB/m	dB	dB	cm	deg
1	0.05	35.90	-78.36	114.26	15.36	20.47	0.07	0.00	0	100 Peak
2	0.08	33.32	-76.44	109.76	13.19	20.05	0.08	0.00	0	100 Peak
3 M	0.11	34.04	-72.66	106.70	14.23	19.73	0.08	0.00	0	100 Peak

- Note 1: ">20dB" means spurious emission levels that exceed the level of 6 dB below the applicable limit.
- Note 2: "N/F" means Nothing Found spurious emissions (No spurious emissions were detected.)
- Note 3: Measurement worst emissions of receive antenna polarization: H (Horizontal).
- Note 4: No level of unwanted emissions exceeds the level of the fundamental emission.
- Note 5: Except fundamental emission, other emissions from digital circuitry used to control additional panel functions or display capabilities other than the touch panel radio transmission. While disable touch panel radio transmission, other emissions have the same levels. Therefore other emissions level could be exceed the fundamental emission level.
- Note 6 : Below 30MHz of spurious emissions that are attenuated by more than 20 dB below the permissible value has no need to be reported.



Transmitter Radiated Emissions (150kHz~30MHz)																																																					
Mode	Touch Panel	Test Freq.(kHz)	562.5																																																		
Operating Mode	1	Polarization	H																																																		
<div style="display: flex; justify-content: space-between;"> Level (dBuV/m) Date: 2019-10-25 </div>																																																					
<table border="1" style="width:100%; border-collapse: collapse; margin-top: 20px;"> <thead> <tr> <th></th> <th>Freq</th> <th>Level</th> <th>Over Limit</th> <th>Limit Line</th> <th>ReadAntenna Level</th> <th>Cable Preamp</th> <th>A/Pos</th> <th>T/Pos</th> <th>Remark</th> </tr> <tr> <th></th> <th>MHz</th> <th>dBuV/m</th> <th>dB</th> <th>dBuV/m</th> <th>dBuV</th> <th>dB/m</th> <th>dB</th> <th>dB</th> <th>cm deg</th> </tr> </thead> <tbody> <tr> <td>1</td> <td>4.45</td> <td>34.92</td> <td>-34.62</td> <td>69.54</td> <td>14.18</td> <td>20.32</td> <td>0.42</td> <td>0.00</td> <td>360 100 Peak</td> </tr> <tr> <td>2 M</td> <td>13.55</td> <td>35.15</td> <td>-34.39</td> <td>69.54</td> <td>12.28</td> <td>22.18</td> <td>0.69</td> <td>0.00</td> <td>360 100 Peak</td> </tr> <tr> <td>3</td> <td>21.70</td> <td>33.81</td> <td>-35.73</td> <td>69.54</td> <td>10.32</td> <td>22.62</td> <td>0.87</td> <td>0.00</td> <td>360 100 Peak</td> </tr> </tbody> </table>					Freq	Level	Over Limit	Limit Line	ReadAntenna Level	Cable Preamp	A/Pos	T/Pos	Remark		MHz	dBuV/m	dB	dBuV/m	dBuV	dB/m	dB	dB	cm deg	1	4.45	34.92	-34.62	69.54	14.18	20.32	0.42	0.00	360 100 Peak	2 M	13.55	35.15	-34.39	69.54	12.28	22.18	0.69	0.00	360 100 Peak	3	21.70	33.81	-35.73	69.54	10.32	22.62	0.87	0.00	360 100 Peak
	Freq	Level	Over Limit	Limit Line	ReadAntenna Level	Cable Preamp	A/Pos	T/Pos	Remark																																												
	MHz	dBuV/m	dB	dBuV/m	dBuV	dB/m	dB	dB	cm deg																																												
1	4.45	34.92	-34.62	69.54	14.18	20.32	0.42	0.00	360 100 Peak																																												
2 M	13.55	35.15	-34.39	69.54	12.28	22.18	0.69	0.00	360 100 Peak																																												
3	21.70	33.81	-35.73	69.54	10.32	22.62	0.87	0.00	360 100 Peak																																												
<p>Note 1: ">20dB" means spurious emission levels that exceed the level of 6 dB below the applicable limit.</p> <p>Note 2: "N/F" means Nothing Found spurious emissions (No spurious emissions were detected.)</p> <p>Note 3: Measurement worst emissions of receive antenna polarization: H (Horizontal).</p> <p>Note 4: No level of unwanted emissions exceeds the level of the fundamental emission.</p> <p>Note 5: Except fundamental emission, other emissions from digital circuitry used to control additional panel functions or display capabilities other than the touch panel radio transmission. While disable touch panel radio transmission, other emissions have the same levels. Therefore other emissions level could be exceed the fundamental emission level.</p> <p>Note 6 : Below 30MHz of spurious emissions that are attenuated by more than 20 dB below the permissible value has no need to be reported.</p>																																																					



3.2.6 Transmitter Radiated Emissions (Above 30MHz)

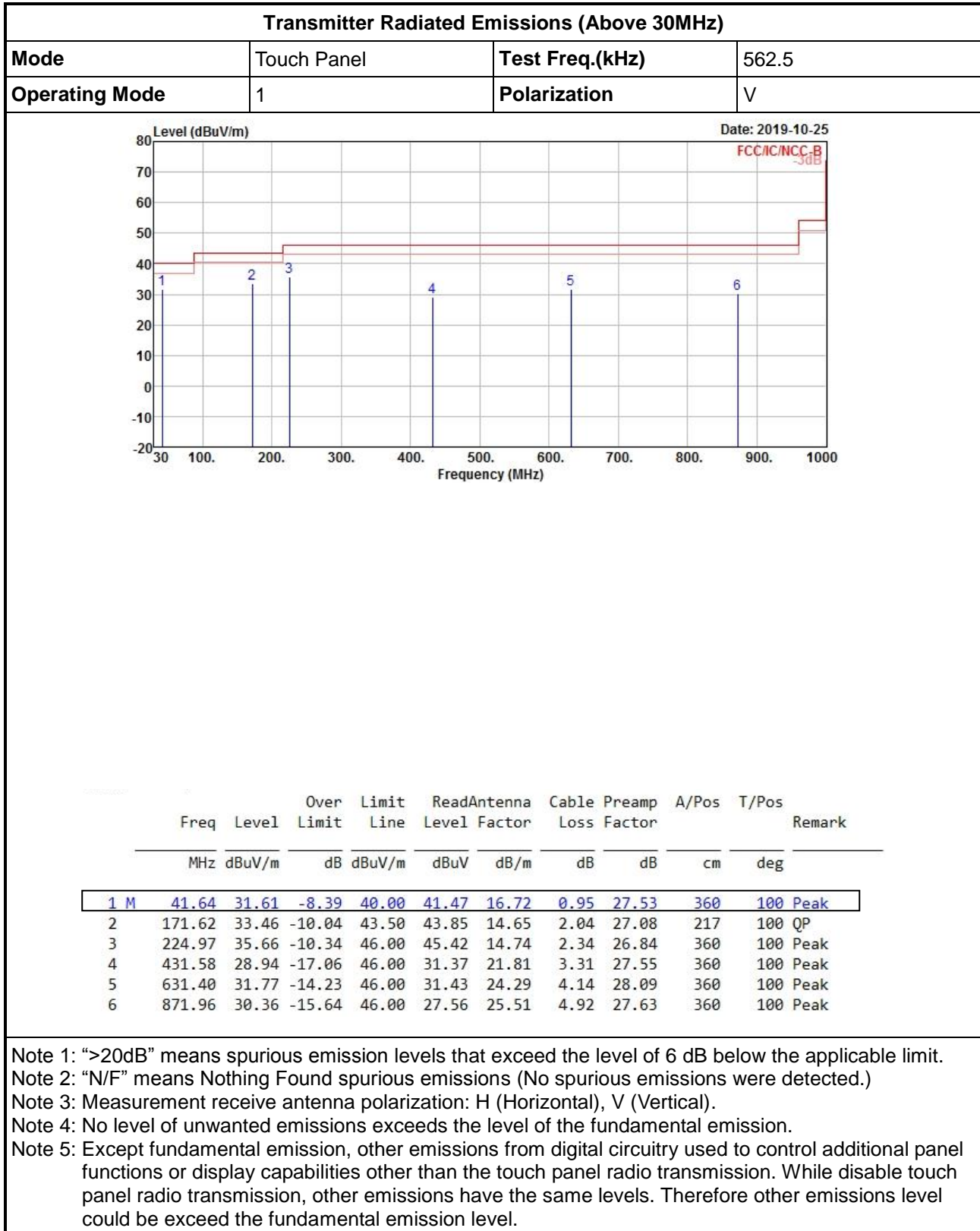



Transmitter Radiated Emissions (Above 30MHz)			
Mode	Touch Panel	Test Freq.(kHz)	592.5
Operating Mode	1	Polarization	H

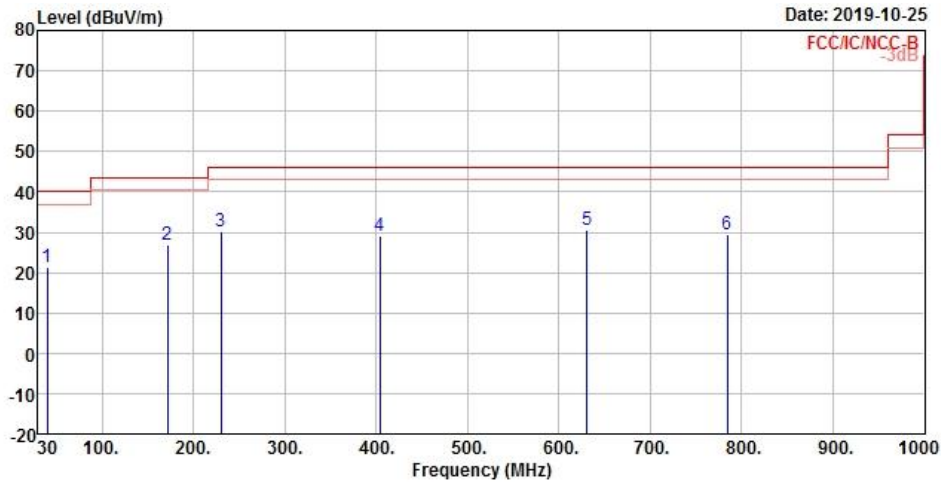

	Freq	Level	Over Limit	Limit Line	ReadAntenna Level	Antenna Factor	Cable Loss	Preamp Factor	A/Pos	T/Pos	Remark
	MHz	dBUV/m	dB	dBUV/m	dBuV	dB/m	dB	dB	cm	deg	
1	39.70	21.40	-18.60	40.00	30.39	17.62	0.93	27.54	0	100	Peak
2	171.62	26.71	-16.79	43.50	37.10	14.65	2.04	27.08	0	100	Peak
3	229.82	30.02	-15.98	46.00	39.25	15.22	2.37	26.82	0	100	Peak
4	404.42	29.01	-16.99	46.00	32.01	21.13	3.20	27.33	0	100	Peak
5 M	630.43	30.61	-15.39	46.00	30.27	24.29	4.14	28.09	0	100	Peak
6	784.66	29.47	-16.53	46.00	27.64	25.07	4.68	27.92	0	100	Peak

Note 1: ">20dB" means spurious emission levels that exceed the level of 6 dB below the applicable limit.
 Note 2: "N/F" means Nothing Found spurious emissions (No spurious emissions were detected.)
 Note 3: Measurement receive antenna polarization: H (Horizontal), V (Vertical).
 Note 4: No level of unwanted emissions exceeds the level of the fundamental emission.
 Note 5: Except fundamental emission, other emissions from digital circuitry used to control additional panel functions or display capabilities other than the touch panel radio transmission. While disable touch panel radio transmission, other emissions have the same levels. Therefore other emissions level could be exceed the fundamental emission level.

3.3 Emission Bandwidth

3.3.1 Emission Bandwidth Limit

Emission Bandwidth Limit
N/A

3.3.2 Measuring Instruments

Refer a test equipment and calibration data table in this test report.

3.3.3 Test Procedures

Test Method
<input checked="" type="checkbox"/> For the emission bandwidth refer ANSI C63.10, clause 6.9.3 for occupied bandwidth testing.
<input checked="" type="checkbox"/> For radiated measurement. Loop antenna was rotated about the horizontal and vertical axis and the equipment to be measured and the test antenna shall be oriented to obtain the maximum emitted field strength level.

3.3.4 Test Setup

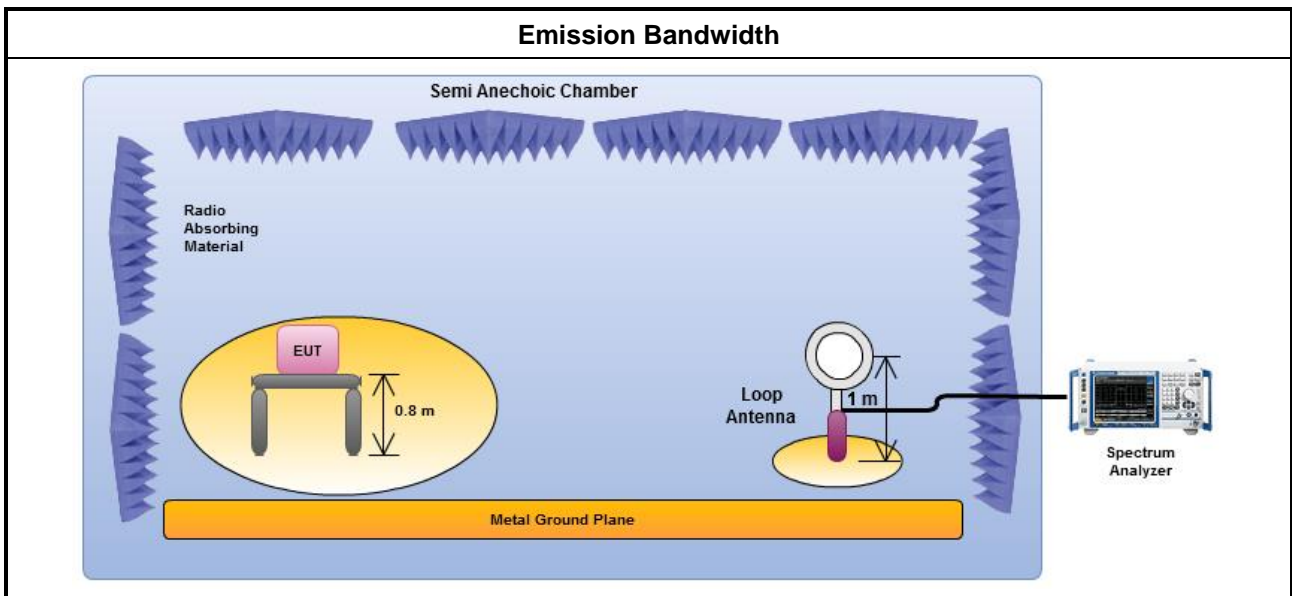



3.3.5 Test Result of Emission Bandwidth

Occupied Channel Bandwidth Result			
Transmitter Mode	Frequency (kHz)	99% Bandwidth (kHz)	20dB Bandwidth (kHz)
Touch Panel	562.5	34.88	18.81
Limit		N/A	
Result		Complied	

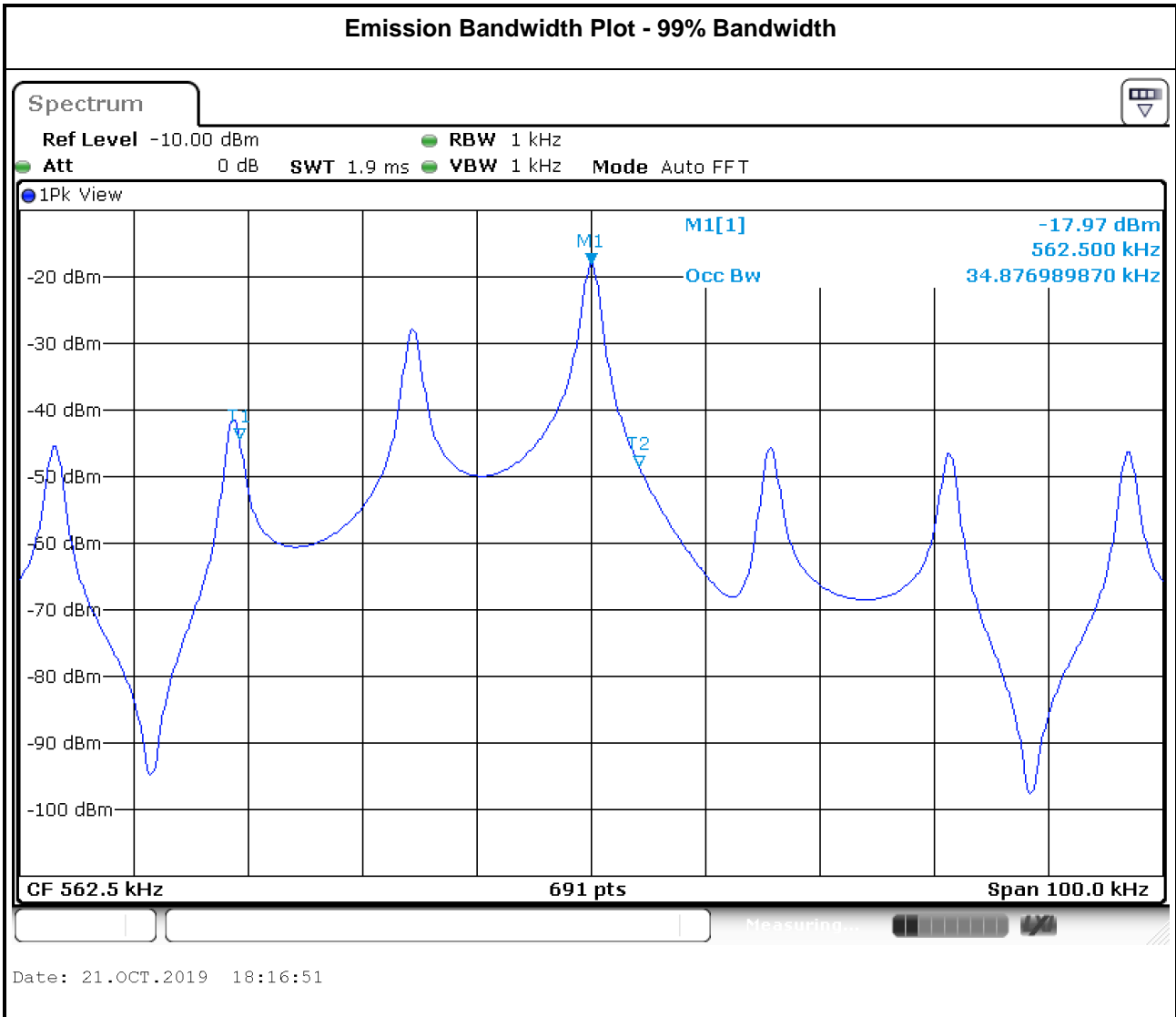

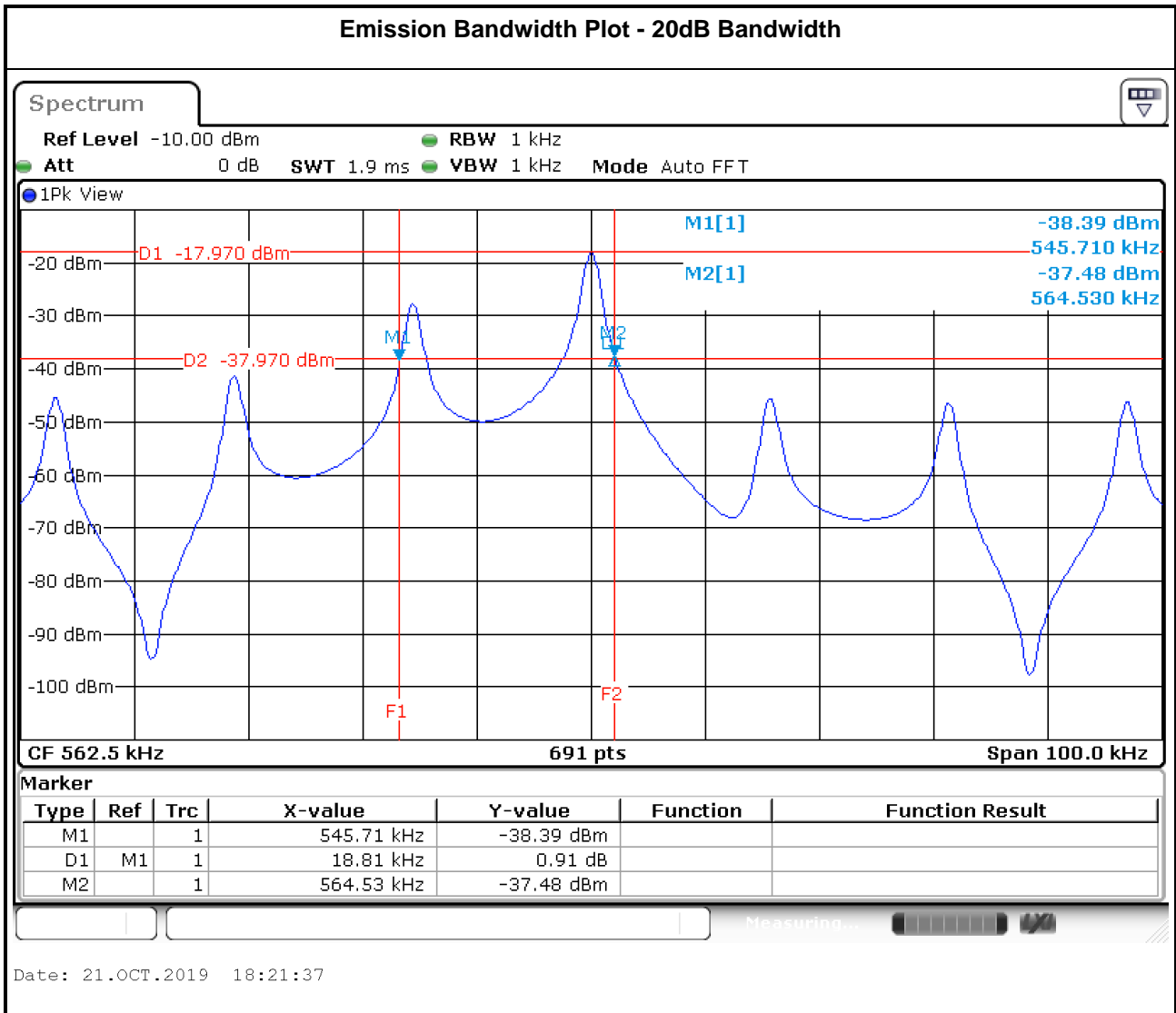



4 Test Equipment and Calibration Data

<AC Power-line Conducted Emissions>

Instrument	Manufacturer	Model No.	Serial No.	Characteristics	Calibration Date	Calibration Due Date
EMC Receiver	R&S	ESR3	102052	9kHz~3.6GHz	09/Apr/2019	08/Apr/2020
LISN	R&S	ENV216	101295	9kHz~30MHz	08/Nov/2018	07/Nov/2019
RF Cable-CON	MTJ	RG142	CB002-CO	9kHz~200MHz	12/Sep/2019	11/Sep/2020
AC POWER	APC	AFC-11005G	F310050055	47Hz~63Hz 5~300V	NCR	NCR
Impuls Begrenzer Pulse Limiter	SCHWARZBECK	VTSD 9561-F	9561-F041	9kHz~30MHz	24/Sep/2019	23/Sep/2020

NCR : Non-Calibration Require

<RF Conducted>

Instrument	Manufacturer	Model No.	Serial No.	Characteristics	Calibration Date	Calibration Due Date
Spectrum Analyzer	R&S	FSV 40	101013	10Hz~40GHz	13/Mar/2019	12/Mar/2020
Loop Antenna	TESEQ	HLA 6120	31244	9kHz~30MHz	15/Mar/2019	14/Mar/2020

<Radiated Emission>

Instrument	Manufacturer	Model No.	Serial No.	Characteristics	Calibration Date	Calibration Due Date
3m Semi Anechoic Chamber	SIDT FRANKONIA	SAC-3M	03CH03-HY	30MHz~1GHz 3m	30/Aug/2019	29/Aug/2020
3m Semi Anechoic Chamber	SIDT FRANKONIA	SAC-3M	03CH03-HY	1GHz~18GHz 3m	30/Aug/2019	29/Aug/2020
Amplifier	HP	8447D	2944A08033	10kHz~1.3GHz	22/Apr/2019	21/Apr/2020
EMI Test Receiver	R&S	ESR3	102052	9kHz~3.6GHz	09/Apr/2019	08/Apr/2020
Bilog Antenna with 5dB Pad	ETS	3142B & MTJ6102-05	00022055	26 MHz~3 GHz	19/Nov/2018	18/Nov/2019
Signal Analyzer	R&S	FSV40	101500	10Hz~40GHz	15/Aug/2019	14/Aug/2020
RF Cable-R03m	Jye Bao	RG142	CB021	9kHz~1GHz	22/Mar/2019	21/Mar/2020
Loop Antenna	TESEQ	HLA 6120	31244	9kHz~30MHz	15/Mar/2019	14/Mar/2020