



Zacta

TEST REPORT

Report number : JPD-TR-17124-0

Issue date : May 23, 2017

The device, as described herewith, was tested pursuant to applicable test procedure and complies with the requirements of;

FCC Part15 Subpart C

The test results are traceable to the international or national standards.

Applicant	: Wacom Co., Ltd.
Equipment under test (EUT)	: Pen Tablet
Model number	: CTL-672
FCC ID	: HV4CTL672

Date of test : May 11, 12, 13, 2017
 Test place : TÜV SÜD Zacta Ltd. Yonezawa Testing Center
 5-4149-7, Hachimanpara, Yonezawa-shi,
 Yamagata, 992-1128 Japan
 Phone: +81-238-28-2881 Fax: +81-238-28-2888
 Test results : Complied

The results in this report are applicable only to the equipment tested.
 This report shall not be re-produced except in full without the written approval of TÜV SÜD Zacta Ltd.
 This test report must not be used by the client to claim product certification, approval, or endorsement by NVLAP, NIST, ILAC-MRA or any agency of the federal government.

Tested by : Taiki Watanabe Hikaru Shibata
 Taiki Watanabe Hikaru Shibata

Approved by : Hiroaki Suzuki
 Hiroaki Suzuki
 Lab Manager of RF Lab



NVLAP LAB CODE 200306-0



Table of contents

	Page
1. Summary of Test	3
1.1 Purpose of test	3
1.2 Standards	3
1.3 List of applied test to the EUT	3
1.4 Modification to the EUT by laboratory	3
2. Equipment Under Test	4
2.1 General Description of equipment	4
2.2 EUT information	4
2.3 Variation of the family model(s)	4
2.4 Operating mode	4
3. Configuration of equipment	5
3.1 Equipment(s) used	5
3.2 Cable(s) used	5
3.3 System configuration	6
4. Radiated Emissions	7
4.1 Measurement procedure	7
4.2 Calculation method	8
4.3 Limit	9
4.4 Test data	10
5. AC Power Line Conducted Emissions	12
5.1 Measurement procedure	12
5.2 Calculation method	12
5.3 Limit	13
5.4 Test data	13
6. Uncertainty of measurement	14
7. Laboratory description	15
Appendix A. Test equipment	16



Zacta

1. Summary of Test

1.1 Purpose of test

It is the original test in order to verify conformance to FCC Part 15 Subpart C.

1.2 Standards

CFR47 FCC Part 15 Subpart C

1.2.1 Test Methods

ANSI C63.10-2013

1.2.2 Deviation from standards

None

1.3 List of applied test to the EUT

Test items Section	Classification of EUT	Condition	Result
15.209	Radiated Emissions	Radiated	PASS
15.207	AC Power Line Conducted Emissions	Conducted	PASS

1.3.1 Test set up

Table-Top

1.4 Modification to the EUT by laboratory

None



Zacta

2. Equipment Under Test

2.1 General Description of equipment

EUT is the Pen Tablet.

2.2 EUT information

Applicant	:	Wacom Co., Ltd. 2-510-1, Toyonodai, Kazo-shi, Saitama, 349-1148 Japan Phone: +81-480-78-1211 Fax: +81-480-78-1404
Equipment under test	:	Wacom
Trade name	:	Pen tablet
Model number	:	CTL-672
Serial number	:	N/A
EUT condition	:	Pre-Production
Power ratings	:	DC 5V (USB)
Size	:	(W) 277× (D) 189 × (H) 7.5 mm
Environment	:	Indoor use
Terminal limitation	:	-20°C to 60°C
RF Specification	:	
Frequency range	:	667kHz
Modulation method	:	OOK (On-Off Keying)

2.3 Variation of the family model(s)

Not applicable

2.4 Operating mode

[Normal Operation]

- i) Tablet test setup
- ii) Select a Packet measurement
- iii) Start test mode

3. Configuration of equipment

3.1 Equipment(s) used

No.	Equipment	Company	Model No.	Serial No.	FCC ID / DoC	Comment
1	Pen Tablet	Wacom	CTL-672	N/A	HV4CTL672	EUT
2	Pen	Wacom	LP-190	N/A	-	Accessory
3	Personal Computer	DELL	DMC	H6P61BX	DoC	-
4	PS/2 Mouse	DELL	M071KC	407019830	DoC	-
5	Keyboard	DELL	SK-8110	N/A	DoC	-
6	Display	LG	W1946TW	111NDLSAE064	BEJW1946TW	-
7	Printer	SII	DPU-414	1000169C	DoC	-
8	AC Adaptor for Printer	SII	PW-4007-JU1-E	0948	N/A	-

3.2 Cable(s) used

No.	Cable	Length[m]	Shield	Connector	Comment
a	USB cable	1.0	Yes	Metal	Accessory
b	Mouse cable	1.8	No	Metal	-
c	Keyboard cable	2.0	Yes	Metal	-
d	RGB cable	1.8	Yes	Metal	-
e	AC Power cord for Display	2.0	No	Plastic	-
f	Serial cable	1.8	Yes	Metal	-
g	Parallel cable	2.0	Yes	Metal	-
h	DC cable for Printer AC adapter	2.0	No	Metal	-
i	AC Power cord for Printer AC adapter	2.0	No	Plastic	-
j	AC Power cord for PC	2.5	No	Plastic	-

3.3 System configuration

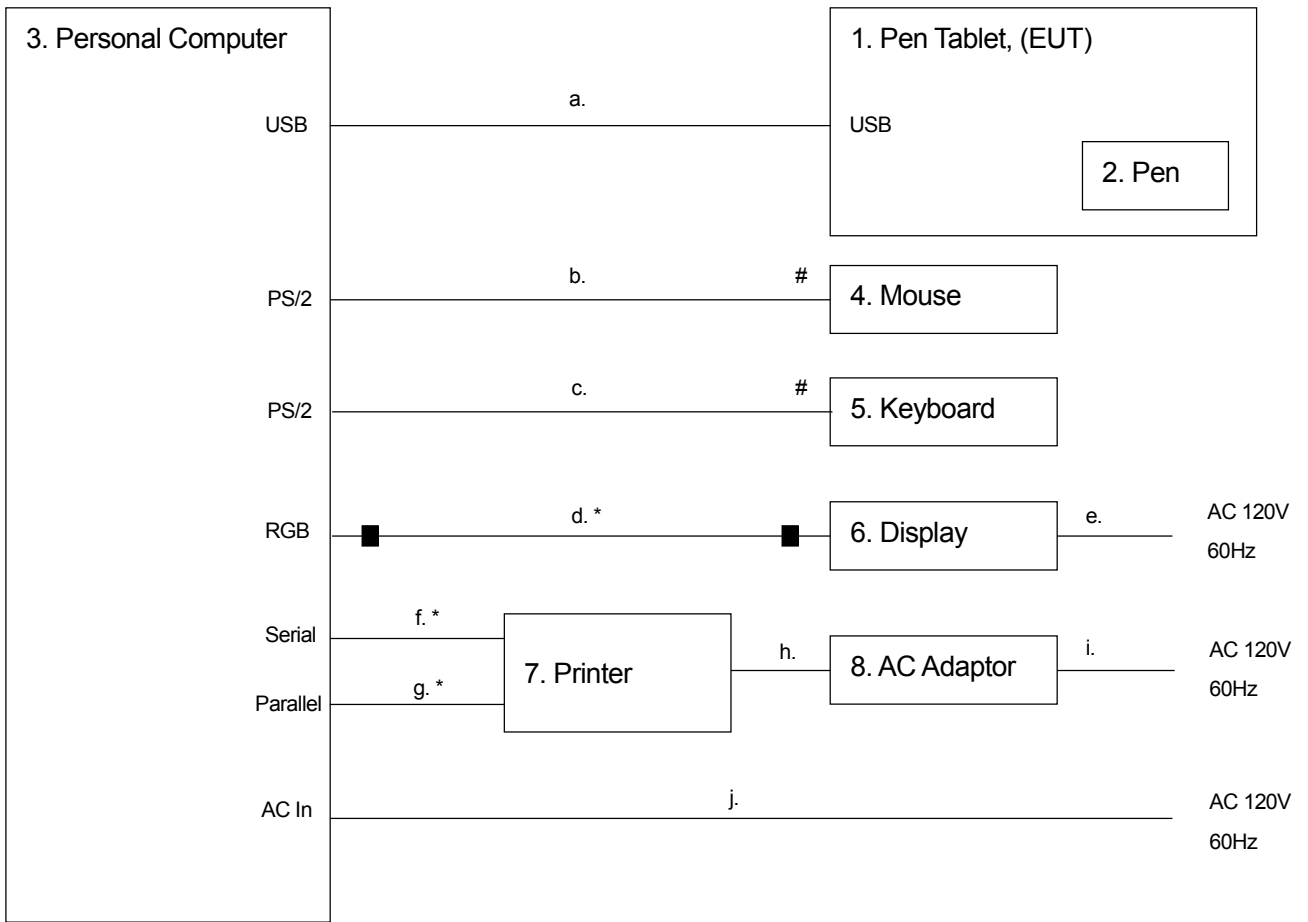

: Un-detachable cable
 ■ : Ferrite core
 * : Bundled excess cable

Note1: Numbers assigned to equipment or cables on this diagram correspond to the list in "3.1 Equipment(s) used" and "3.2 Cable(s) used".
 Note2: Two ferrite cores of RGB cable (No. d) are not an accessory of EUT.

4. Radiated Emissions

4.1 Measurement procedure [FCC 15.209]

Test was applied by following conditions.

Test method	:	ANSI C63.10
Frequency range	:	9kHz to 30MHz
Test place	:	10m Semi-anechoic chamber No.1
EUT was placed on	:	FRP table / (W)2.0m × (D)1.0m × (H)0.8m
Antenna distance	:	3m

Test receiver setting	:	
- Detector	:	Average (9kHz-90kHz, 110kHz-490kHz), Quasi-peak
- Bandwidth	:	200Hz, 120kHz

Although these tests were performed other than open area test site, adequate comparison measurements were confirmed against 30 m open area test site.

Therefore sufficient tests were made to demonstrate that the alternative site produces results that correlate with the ones of tests made in an open field based on KDB 414788.

EUT operating mode is selected to emit the maximum noise. Overall frequency range is investigated with spectrum analyzer using peak detector. Then, emission measurements up to 30MHz were performed with test receiver in above setting. The turntable and the Loop antenna are rotated by 360 degrees and stopped at azimuth of producing the maximum emission. Sufficient time for EUT, peripherals and test equipment is provided in order for them to warm up to their normal operating condition.

- Test configuration

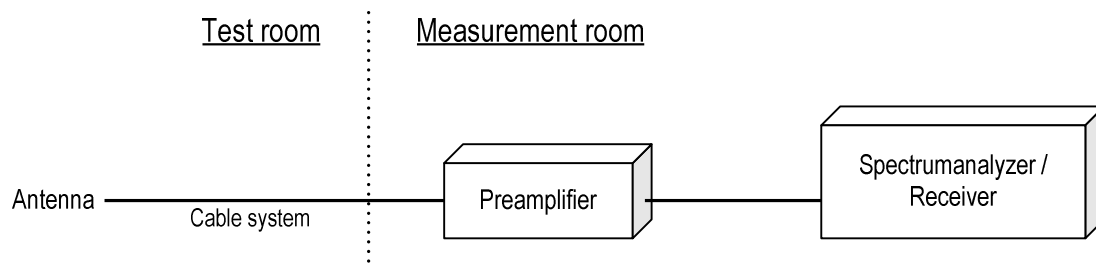

Test was applied by following conditions.

Test method : ANSI C63.10
 Frequency range : 30MHz to 1000MHz
 Test place : 10m Semi-anechoic chamber No.1
 EUT was placed on : FRP table / (W)2.0m × (D)1.0m × (H)0.8m
 Antenna distance : 3m

Test receiver setting
 - Detector : Quasi-peak
 - Bandwidth : 120kHz

EUT operating mode is selected to emit the maximum noise. Overall frequency range is investigated with spectrum analyzer using peak detector. Then, emission measurements up to 1000MHz were performed with test receiver in above setting. In order to find the maximum emissions, antenna is adjusted between 1m and 4m in height and varied its polarization (horizontal and vertical), and EUT azimuth was also varied by rotating turntable 0 to 360 degrees. Sufficient time for EUT, peripherals and test equipment is provided in order for them to warm up to their normal operating condition.

- Test configuration

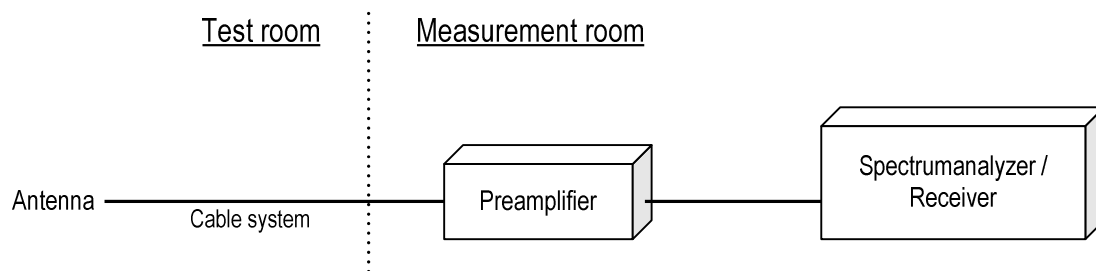

4.2 Calculation method

[9kHz to 150kHz]

Emission level = Reading + (Ant. factor + Cable system loss)

Margin = Limit – Emission level

[150kHz to 1000MHz]

Emission level = Reading + (Ant. factor + Cable system loss – Amp. Gain)

Margin = Limit – Emission level

Example:

Limit @ 350.0MHz : 37.0dB μ V/m

Reading = 41.1dB μ V c.f = -11.8dB/m

Emission level = 41.1 - 11.8 = 29.3dB μ V/m

Margin = 37.0 - 29.3 = 7.7dB

4.3 Limit

Frequency [MHz]	Field strength		Distance [m]
	[uV/m]	[dBuV/m]	
0.009-0.490	2400 / F [kHz]	20logE [uV/m]	300
0.490-1.705	24000 / F [kHz]	20logE [uV/m]	30
1.705-30	30	29.5	30
30-88	100	40.0	3
88-216	150	43.5	3
216-960	200	46.0	3
Above 960	300	54.0	3

Frequency [MHz]	Limit [dBuV/m]	Distance [m]
30-300	30	10
300-1000	37	10

Note:

1. The lower limit shall apply at the transition frequencies.
2. Emission level [dBuV/m] = 20log Emission [uV/m]
3. Measurements were corrected to 30m using $40\log(3/30) = -40.0\text{dB}$
4. CISPR 22 limit was applied radiated emission measurements as prescribed in FCC Part 15 section 15.109(g).



Zacta

4.4 Test data

Date : May 13, 2017

Temperature : 24.1 [°C]

Humidity : 42.8 [%]

Test place : 10m Semi-anechoic chamber No.1

Test engineer :

Taiki Watanabe**[9kHz to 30MHz]****CTL-472****Pen: LP-190**

Frequency [MHz]	Reading [dBuV] At 3m	c.f [dB(1/m)]	Result [dBuV/m] At 3m	Result [dBuV/m] At 30m	Limit [dBuV/m] At 30m	Margin [dB]	Result
0.667	50.8	-4.3	46.5	6.5	31.1	24.6	PASS
1.254	35.0	-4.3	30.7	-9.3	25.6	34.9	PASS
1.334	28.6	-4.3	24.3	-15.7	25.1	40.8	PASS
2.001	36.2	-4.3	31.9	-8.1	29.5	37.6	PASS
2.710	28.0	-4.2	23.8	-16.2	29.5	45.7	PASS
22.280	34.6	-2.7	31.9	-8.1	29.5	37.6	PASS



Zacta

**[30MHz to 1000MHz]
CTL-672
Pen: LP-190**

***** RADIATED EMISSION *****
[10m Semi-anechoic chamber #1]

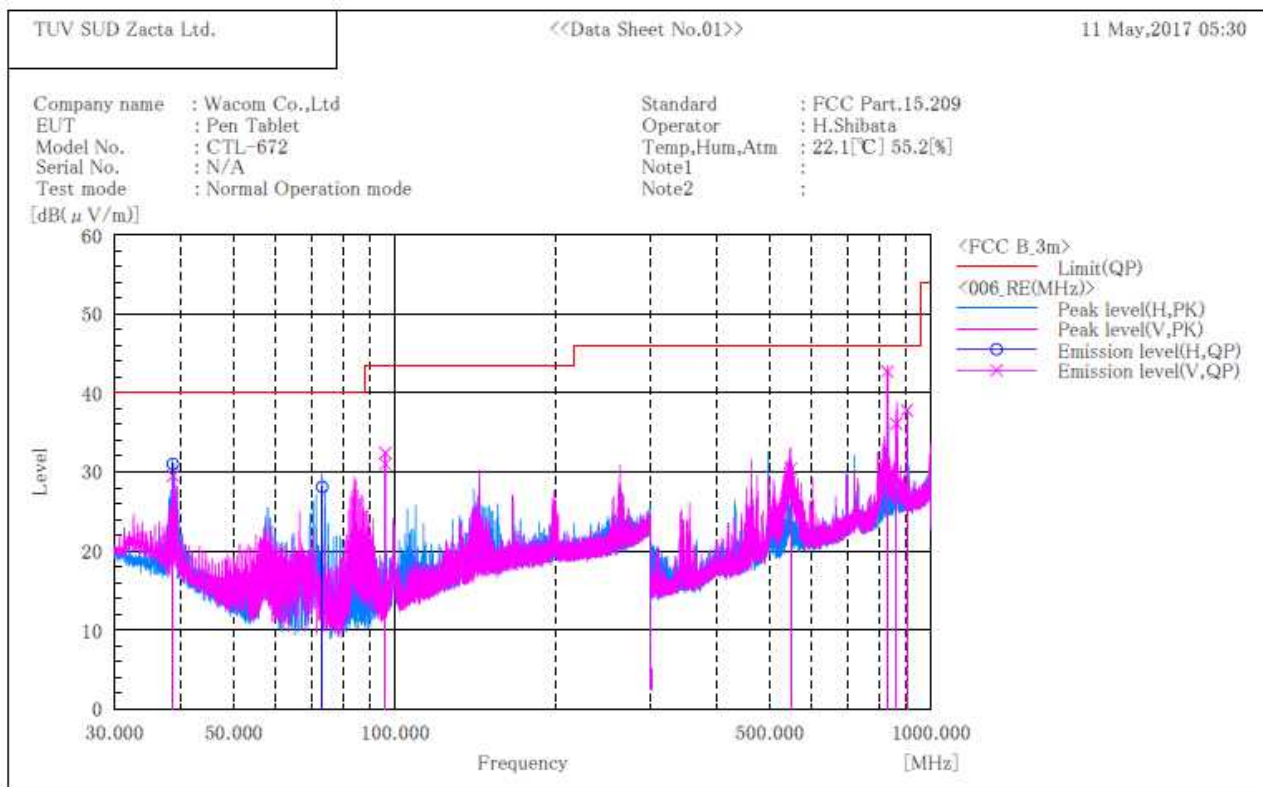

Final Result

No.	Frequency [MHz]	(P)	Reading QP [dB(μV)]	c.f [dB(1/m)]	Result QP [dB(μV/m)]	Limit QP [dB(μV/m)]	Margin QP [dB]	Height [cm]	Angle [°]
1	38.599	H	38.7	-7.7	31.0	40.0	9.0	398.0	24.0
2	38.600	V	37.2	-7.7	29.5	40.0	10.5	100.0	313.0
3	73.335	H	44.1	-16.0	28.1	40.0	11.9	276.0	82.0
4	96.129	V	43.6	-12.6	31.0	43.5	12.5	290.0	140.0
5	96.135	V	45.0	-12.6	32.4	43.5	11.1	100.0	285.0
6	548.510	V	34.2	-3.8	30.4	46.0	15.6	100.0	247.0
7	829.940	V	42.0	0.7	42.7	46.0	3.3	133.0	2.0
8	862.861	V	34.7	1.4	36.1	46.0	9.9	200.0	308.0
9	902.930	V	35.9	1.9	37.8	46.0	8.2	192.0	8.0

5. AC Power Line Conducted Emissions

5.1 Measurement procedure [FCC 15.207]

Test was applied by following conditions.

Test method	: ANSI C63.10
Frequency range	: 0.15MHz to 30MHz
Test place	: 10m Semi-anechoic chamber No.1
EUT was placed on	: FRP table / (W)2.0m × (D)1.0m × (H)0.8m
Vertical Metal Reference Plane	: (W)2.0m × (H)2.0m 0.4m away from EUT
Test receiver setting	
- Detector	: Quasi-peak, Average
- Bandwidth	: 9kHz

EUT and peripherals are connected to 50Ω/50μH Line Impedance Stabilization Network (LISN) which are connected to reference ground plane, and are placed 80cm away from EUT. Excess of AC power cable is bundled in center.

LISN for peripheral is terminated in 50Ω.

EUT operating mode is selected to emit the maximum noise. Overall frequency range is investigated with spectrum analyzer using peak detector. Maximum emission configuration is determined by manipulating the EUT, peripherals, interconnecting cables. Then, emission measurements are performed with test receiver in above setting to each current-carrying conductor of the mains port. Sufficient time for EUT, peripherals and test equipment is provided in order for them to warm up to their normal operating condition. If the average limit is met when using a quasi-peak detector receiver, the EUT shall be deemed to meet both limits.

- Test configuration

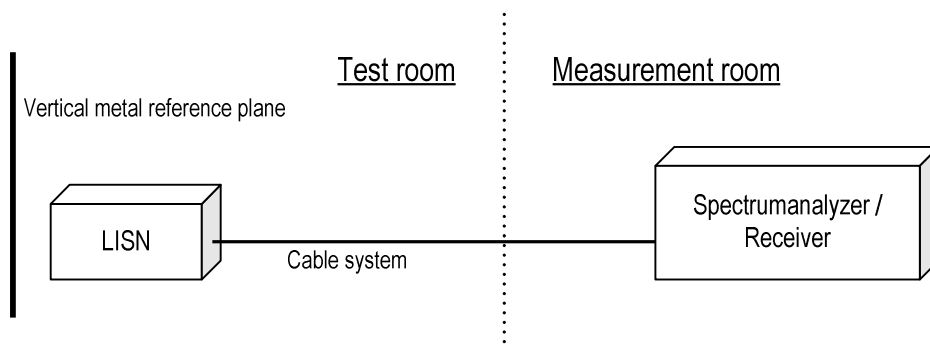

5.2 Calculation method

Emission level = Reading + (LISN. factor + Cable system loss)

Margin = Limit – Emission level

Example:

Limit @ 6.770MHz : 60.0dBμV(Quasi-peak)
: 50.0dBμV(Average)

(Quasi peak) Reading = 41.2dBμV c.f = 10.3dB
Emission level = 41.2 + 10.3 = 51.5dBμV
Margin = 60.0 – 51.5 = 8.5dB

(Average) Reading = 35.0dBμV c.f = 10.3dB
Emission level = 35.0 + 10.3 = 45.3dBμV
Margin = 50.0 – 45.3 = 4.7dB



Zacta

5.3 Limit

Frequency [MHz]	Limit	
	QP [dBuV]	AV [dBuV]
0.15-0.5	66-56*	56-46*
0.5-5	56	46
5-30	60	50

*: The limit decreases linearly with the logarithm of the frequency in the range 0.15MHz to 0.5MHz.

5.4 Test data

***** CONDUCTED EMISSION at MAINS PORT *****
[10m semi-anechoic chamber #1]

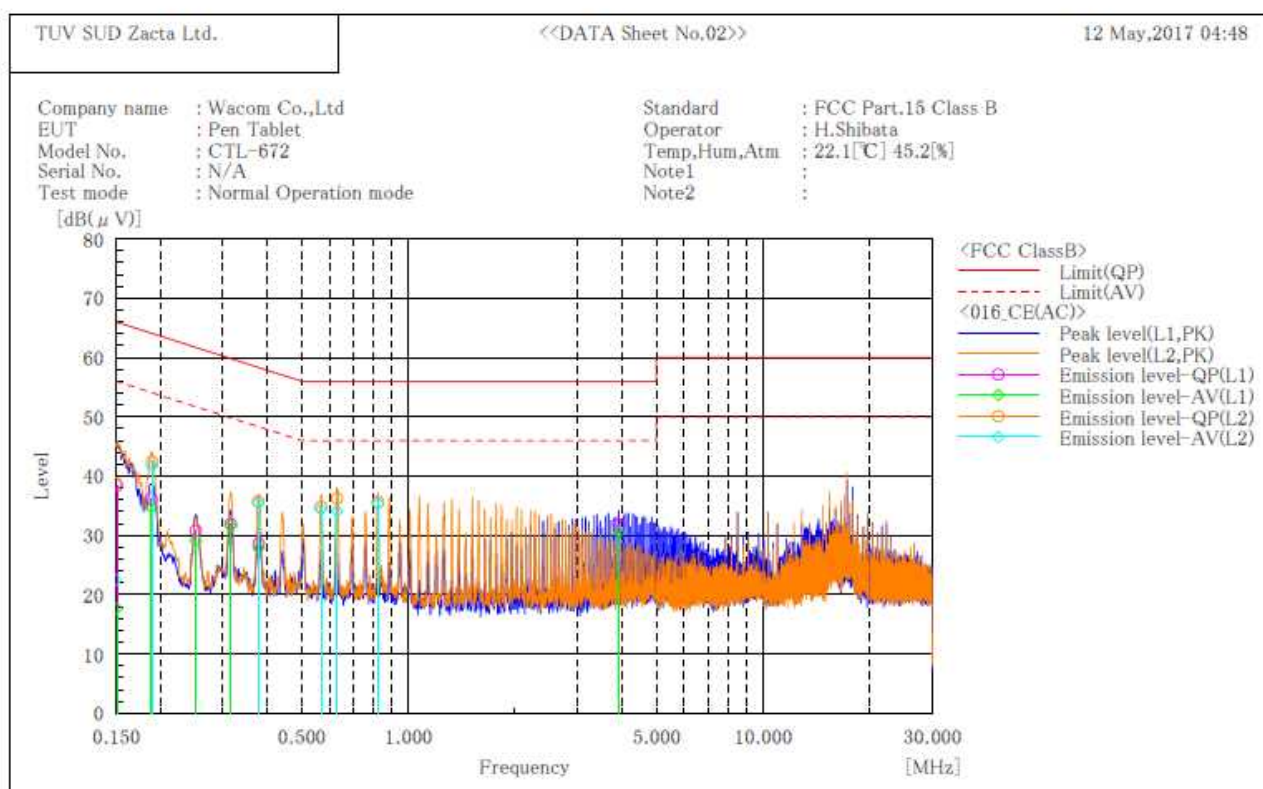

Final Result

--- L1 Phase ---

No.	Frequency [MHz]	Reading QP [dB(μV)]	Reading AV [dB(μV)]	c. f [dB]	Result QP [dB(μV)]	Result AV [dB(μV)]	Limit QP [dB(μV)]	Limit AV [dB(μV)]	Margin QP [dB]	Margin AV [dB]
1	0.151	28.1	7.4	10.3	38.4	17.7	65.9	55.9	27.5	38.2
2	0.189	25.9	24.4	10.3	36.2	34.7	64.1	54.1	27.9	19.4
3	0.252	20.6	18.9	10.2	30.8	29.1	61.7	51.7	30.9	22.6
4	0.316	21.7	21.4	10.2	31.9	31.6	59.8	49.8	27.9	18.2
5	0.379	18.4	17.6	10.2	28.6	27.8	58.3	48.3	29.7	20.5
6	3.920	21.3	20.0	10.5	31.8	30.5	56.0	46.0	24.2	15.5

--- L2 Phase ---

No.	Frequency [MHz]	Reading QP [dB(μV)]	Reading AV [dB(μV)]	c. f [dB]	Result QP [dB(μV)]	Result AV [dB(μV)]	Limit QP [dB(μV)]	Limit AV [dB(μV)]	Margin QP [dB]	Margin AV [dB]
1	0.150	28.5	12.2	10.3	38.8	22.5	66.0	56.0	27.2	33.5
2	0.190	32.1	31.4	10.3	42.4	41.7	64.0	54.0	21.6	12.3
3	0.378	25.4	25.2	10.3	35.7	35.5	58.3	48.3	22.6	12.8
4	0.568	24.5	24.1	10.3	34.8	34.4	56.0	46.0	21.2	11.6
5	0.630	25.9	23.8	10.3	36.2	34.1	56.0	46.0	19.8	11.9
6	0.822	25.2	25.0	10.4	35.6	35.4	56.0	46.0	20.4	10.6



6. Uncertainty of measurement

Expanded uncertainties stated are calculated with a coverage Factor $k=2$.

Please note that these results are not taken into account when measurement uncertainty considerations contained in ETSI TR 100 028-0011 determining compliance or non-compliance with test result.

Test item	Measurement uncertainty
Conducted emission at mains port	$\pm 3.0\text{dB}$
Radiated emission (9kHz – 30MHz)	$\pm 4.4\text{dB}$
Radiated emission (30MHz – 1000MHz)	$\pm 4.5\text{dB}$
Radiated emission (1000MHz – 26GHz)	$\pm 3.9\text{dB}$



Zacta

7. Laboratory description

1. Location

Name: Yonezawa Testing Center
 Address: 5-4149-7, Hachimanpara, Yonezawa-shi, Yamagata, 992-1128 Japan
 Phone: +81-238-28-2881
 Fax: +81-238-28-2888

2. Accreditation and Registration

1) NVLAP

LAB CODE: 200306-0

2) VLAC

Accreditation No.: VLAC-013

3) BSMI

Laboratory Code: SL2-IN-E-6018, SL2-A1-E-6018

4) Industry Canada

Site number	Facility	Expiration date
4224A-4	3m Semi-anechoic chamber	2017-12-03
4224A-5	10m Semi-anechoic chamber No.1	2017-12-03
4224A-6	10m Semi-anechoic chamber No.2	2019-12-14

5) VCCI Council

Registration number	Expiration date
A-0166	2017-07-03

Appendix A. Test equipment

Radiated emission

Equipment	Company	Model No.	Serial No.	Cal. due	Cal. date
EMI receiver	ROHDE&SCHWARZ	ESR7	101742	Dec. 31, 2017	Dec. 21, 2016
Preamplifier	ANRITSU	MH648A	M08067	Feb. 28, 2018	Feb. 2, 2017
Loop antenna	R&S	HFH2-Z2	100515	Feb. 28, 2018	Feb. 17, 2017
Attenuator	TDC	TAT-43B-06	N/A(S209)	May 31, 2017	May 10, 2016
Biconical antenna	Schwarzbeck	VHA9103/BBA9106	2850	Jul. 31, 2017	Jul. 14, 2016
Log periodic antenna	Schwarzbeck	UHALP9108A	0991	Jul. 31, 2017	Jul. 14, 2016
Attenuator	TME	CFA-01NPJ-6	N/A(S273)	May 31, 2017	May 25, 2016
Attenuator	TME	CFA-01NPJ-3	N/A(S270)	Feb. 28, 2018	Feb. 2, 2017
Microwave cable	SUHNER	SUCOFLEX104/9m	346315/4	Feb. 28, 2018	Feb. 2, 2017
		SUCOFLEX104/1m	MY24628/4	Feb. 28, 2018	Feb. 3, 2017
		SUCOFLEX104/2m	SN MY28398/4	Feb. 28, 2018	Feb. 2, 2017
		SUCOFLEX106/13m	MY1159/6	Nov. 30, 2017	Nov. 7, 2016
PC	HP	dc7800small	JPA7450FPJ	N/A	N/A
Software	TOYO Corporation	EP5/RE-AJ	0611193/V5.6.0	N/A	N/A
10m Semi an-echoic Chamber	TOKIN	N/A	N/A(9001-NSA3m)	Oct. 31, 2017	Oct. 3, 2016

Conducted emission at mains port

Equipment	Company	Model No.	Serial No.	Cal. due	Cal. date
EMI receiver	ROHDE&SCHWARZ	ESR7	101742	Dec. 31, 2017	Dec. 21, 2016
Attenuator	TYC	BA-PJ-10	N/A(S344)	Feb. 28, 2018	Feb. 2, 2017
Line impedance stabilization network for EUT	Kyoritsu Electrical Works, Ltd.	KNW-407F	8-2003-1	Mar. 31, 2018	Mar. 13, 2017
Line impedance stabilization network for EUT	Kyoritsu Electrical Works, Ltd.	KNW-242C	8-1096-3	Mar. 31, 2018	Mar. 13, 2017
Coaxial cable	FUJIKURA	5D-2W/4m	N/A(S349)	Feb. 28, 2018	Feb. 2, 2017
Microwave cable	SUHNER	SUCOFLEX104/2m	317672/4	Feb. 28, 2018	Feb. 2, 2017
Coaxial cable	SUHNER	RG214/U/25m	N/A(S191)	Feb. 28, 2018	Feb. 3, 2017
50Ω terminator	RS	090-0510	N/A(S058)	Jan. 31, 2018	Jan. 19, 2017
PC	HP	dc7800small	JPA7450FPJ	N/A	N/A
Software	TOYO Corporation	EP5/CE-AJ	0611193/V5.4.11	N/A	N/A
10m Semi an-echoic Chamber	TOKIN	N/A	N/A(9001-NSA3m)	Oct. 31, 2017	Oct. 3, 2016

*: The calibrations of the above equipment are traceable to NIST or equivalent standards of the reference organizations.