

TEST REPORT

Report number : Z071C-13101

Issue date : April 11, 2013

The device, as described herewith, was tested pursuant to applicable test procedure and complies with the requirements of;

FCC Part15 Subpart C Canada IC RSS-210

The test results are traceable to the international or national standards.

Applicant	: Wacom Co., Ltd.
Equipment under test (EUT)	: Pen & Touch Tablet
Model number	: CTH-680
FCC ID	: HV4CTH680
IC Certification number	: 6888A-CTH680

Date of test : April 2, 3, 2013
 Test place : TÜV SÜD Zacta Ltd. Yonezawa Testing Center
 4149-7 Hachimanpara 5-chome
 Yonezawa-shi Yamagata 992-1128 Japan
 Phone: +81-238-28-2880 Fax: +81-238-28-2888
 Test results : Complied

The results in this report are applicable only to the equipment tested.
 This report shall not be re-produced except in full without the written approval of TÜV SÜD Zacta Ltd.
 This test report must not be used by client to claim product certification, approval, or endorsement by NVLAP, NIST, or any agency of the federal government.

Tested by : Hiroaki Suzuki Tsuyoshi Okumura
 Hiroaki Suzuki Tsuyoshi Okumura

Tested by : Hiroomi Tsuchiya
 Hiroomi Tsuchiya

Authorized by : Eiji Akiba
 Eiji Akiba
 Deputy General Manager of technical Department

NVLAP[®]
 NVLAP LAB CODE 200306-0



Table of contents

	Page
1. Summary of Test	3
1.1 Purpose of test	3
1.2 Standards	3
1.3 List of applied test to the EUT	3
1.4 Modification to the EUT by laboratory	3
2. Equipment Under Test	4
2.1 General Description of equipment	4
2.2 EUT information	4
2.3 Variation of the family model(s)	4
2.4 Operating mode	4
3. Configuration of equipment	5
3.1 Equipment(s) used	5
3.2 Cable(s) used	5
3.3 System configuration	6
4. Occupied Bandwidth	7
4.1 Measurement procedure	7
4.2 Limit	7
4.3 Measurement result	7
4.4 Trace data	8
5. Radiated Emissions	9
5.1 Measurement procedure	9
5.2 Calculation method	10
5.3 Limit	11
5.3 Test data	12
6. AC Power Line Conducted Emissions	14
6.1 Measurement procedure	14
6.2 Calculation method	14
6.3 Limit	14
6.3 Test data	15
7. Uncertainty of measurement	17
8. Laboratory description	18
Appendix A. Test equipment	19



Zacta

1. Summary of Test

1.1 Purpose of test

It is the original test in order to verify conformance to FCC Part 15 Subpart C.

1.2 Standards

CFR47 FCC Part 15 Subpart C, RSS-210, RSS-Gen

1.2.1 Test Methods

ANSI C63.4-2003

1.2.2 Deviation from standards

None

1.3 List of applied test to the EUT

Test items Section	Classification of EUT	Condition	Result
RSS-Gen 4.6.1	Occupied Bandwidth	Radiated	PASS
15.209 Rss-210 2.2 RSS-Gen 4.9, 4.10, 4.11	Radiated Emissions	Radiated	PASS
15.207 RSS-Gen 7.2.2	AC Power Line Conducted Emissions	Conducted	PASS

1.3.1 Test set up

Table-Top

1.4 Modification to the EUT by laboratory

None



Zacta

2. Equipment Under Test

2.1 General Description of equipment

The EUT is Pen & Touch Tablet, which is transceiver.

2.2 EUT information

Applicant	:	Wacom Co., Ltd. 2-510-1, Toyonodai, Kazo-shi, Saitama, 349-1148 Japan Phone: +81-480-78-1211 Fax: +81-480-78-1404
Equipment under test	:	Pen & Touch Tablet
Trade name	:	Wacom
Model number	:	CTH-680
Serial number	:	3CDHS00252
EUT condition	:	Pre-production
Max. frequency	:	48MHz
Power ratings	:	DC 5V (USB)
Size	:	(W) 275 × (D) 221.5 × (H) 10.1 mm
Environment	:	Indoor use
Terminal limitation	:	5°C to 40°C
RF Specification Frequency range	:	667kHz
Modulation method	:	OOK (On-Off Keying)
RF emission type designator	:	121KK1D

2.3 Variation of the family model(s)

Not applicable

2.4 Operating mode

[Normal Operation]

- i) Tablet test setup
- ii) Select a Packet measurement
- iii) Start test mode

3. Configuration of equipment

3.1 Equipment(s) used

No.	Equipment	Company	Model No.	Serial No.	FCC ID / DoC	Comment
1	Pen & Touch Tablet	Wacom	CTH-680	3CDHS00252	HV4CTH680	EUT
2	Pen	Wacom	LP180	N/A	-	Accessory
			LP180E	N/A	-	Accessory
3	Personal Computer	DELL	DMC	H6P61BX	DoC	-
4	PS/2 Mouse	COMPAQ	M-S34-6MD	N/A	DoC	-
5	Keyboard	emachines	KB-0108	3B57303492B	DoC	-
6	Printer	SII	DPU-414	1000169C	DoC	-
7	AC Adapter for Printer	SII	PW-4007-JU1-E	0948	-	-
8	Display	DELL	E176FPc	CN-0HC746-46633-5CN-JHCU	DoC	-

3.2 Cable(s) used

No.	Cable	Length[m]	Shield	Connector	Comment
a	USB cable	1.0	Yes	Metal	Accessory
b	Mouse cable	1.8	Yes	Metal	-
c	Keyboard cable	1.9	No	Metal	-
d	Serial cable	1.8	Yes	Metal	-
e	Parallel cable	2.1	Yes	Metal	-
f	DC cable for Printer	1.9	No	Metal	-
g	AC Power cord for Printer AC Adapter	2.0	No	Plastic	-
h	RGB cable	1.9	Yes	Metal	-
i	AC Power cord for Display	1.8	No	Plastic	-
j	AC Power cord for PC	2.0	No	Plastic	-

3.3 System configuration

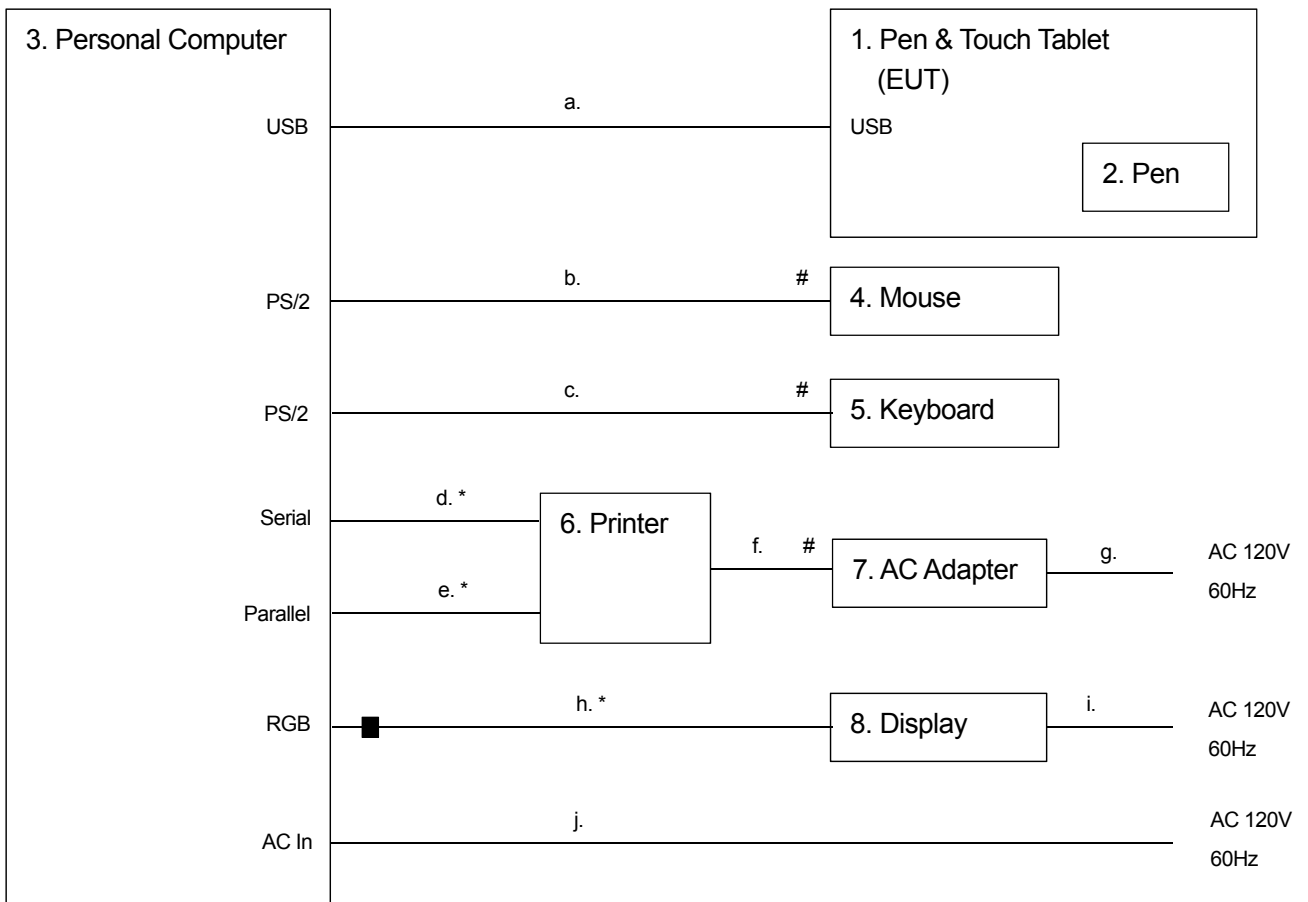

: Un-detachable cable
 ■ : Ferrite core
 * : Bundled excess cable

Note1: Numbers assigned to equipment or cables on this diagram correspond to the list in "3.1 Equipment(s) used" and "3.2 Cable(s) used".
 Note2: One ferrite core of RGB cable (No. h) is not an accessory of EUT.

4. Occupied Bandwidth

4.1 Measurement procedure [IC RSS-Gen 4.6.1]

The transmitter output is connected to the spectrum analyzer. The RBW is set to 1% to 3% of the 99% bandwidth. The VBW is set to 3 times the RBW. The sweep time is coupled. The spectrum analyzer internal 99% bandwidth function is utilized.

The spectrum analyzer is set to;

- RBW=3kHz, VBW=10kHz, Span=300kHz, Sweep=auto

The test mode of EUT is as follows.

- Normal Operation

- Test configuration

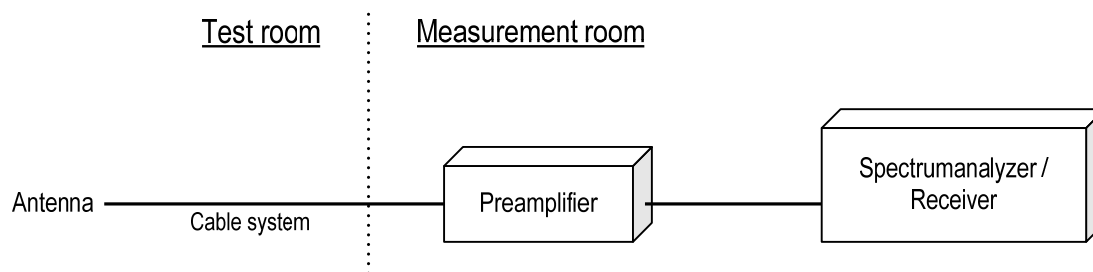

4.2 Limit

None

4.3 Measurement result

Date : Apr. 2, 2013

Temperature : 20.9 [°C]

Humidity : 23.1 [%]

Test place : 3m Semi-anechoic chamber

Test personnel :

Tested by :

Hiroaki Suzuki

Frequency [kHz]	Occupied bandwidth [kHz]
667	121.2



Zacta

4.4 Trace data



Ref 96 dB μ V *Att 10 dB *RBW 3 kHz Marker 1 [T1]
*VBW 10 kHz 83.57 dB μ V
*SWT 100 ms 666.40000000 kHz

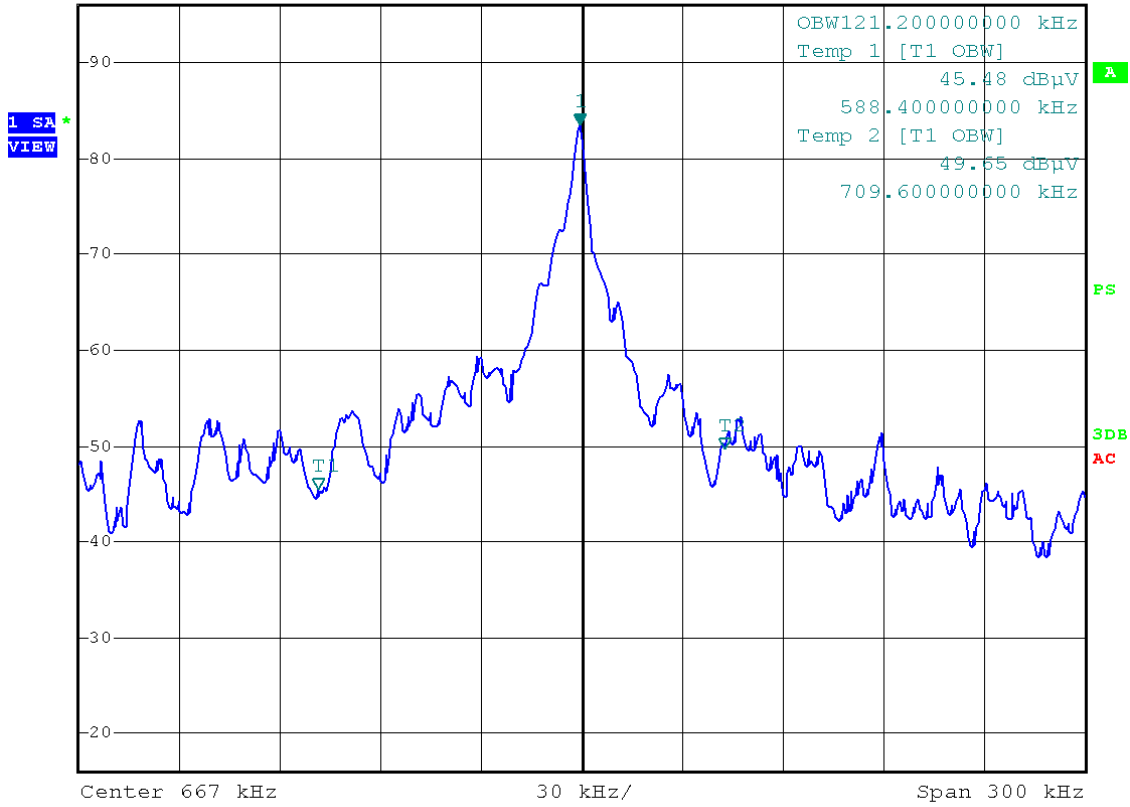

Date: 2.APR.2013 12:49:23

5. Radiated Emissions

5.1 Measurement procedure

[FCC 15.209, IC RSS-210 2.2, IC RSS-Gen 4.9, 4.10, 4.11]

Test was applied by following conditions.

Test method	:	ANSI C63.4
Frequency range	:	9kHz to 30MHz
Test place	:	3m Semi-anechoic chamber
EUT was placed on	:	FRP table / (W)2.0m × (D)1.0m × (H)0.8m
Antenna distance	:	3m

Test receiver setting

- Detector	:	Average (9kHz-90kHz, 110kHz-490kHz), Quasi-peak
- Bandwidth	:	200Hz, 120kHz

EUT operating mode is selected to emit the maximum noise. Overall frequency range is investigated with spectrum analyzer using peak detector. Then, emission measurements up to 30MHz were performed with test receiver in above setting. The turntable and the Loop antenna are rotated by 360 degrees and stopped at azimuth of producing the maximum emission. Sufficient time for EUT, peripherals and test equipment is provided in order for them to warm up to their normal operating condition.

- Test configuration

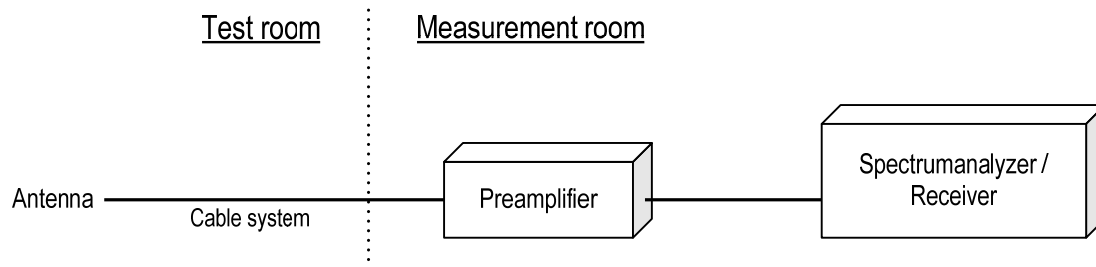

Test was applied by following conditions.

Test method : ANSI C63.4
 Frequency range : 30MHz to 1000MHz
 Test place : 10m Semi-anechoic chamber
 EUT was placed on : FRP table / (W)2.0m × (D)1.0m × (H)0.8m
 Antenna distance : 10m

Test receiver setting
 - Detector : Quasi-peak
 - Bandwidth : 120kHz

EUT operating mode is selected to emit the maximum noise. Overall frequency range is investigated with spectrum analyzer using peak detector. Then, emission measurements up to 1000MHz were performed with test receiver in above setting. In order to find the maximum emissions, antenna is adjusted between 1m and 4m in height and varied its polarization (horizontal and vertical), and EUT azimuth was also varied by rotating turntable 0 to 360 degrees. Sufficient time for EUT, peripherals and test equipment is provided in order for them to warm up to their normal operating condition.

- Test configuration

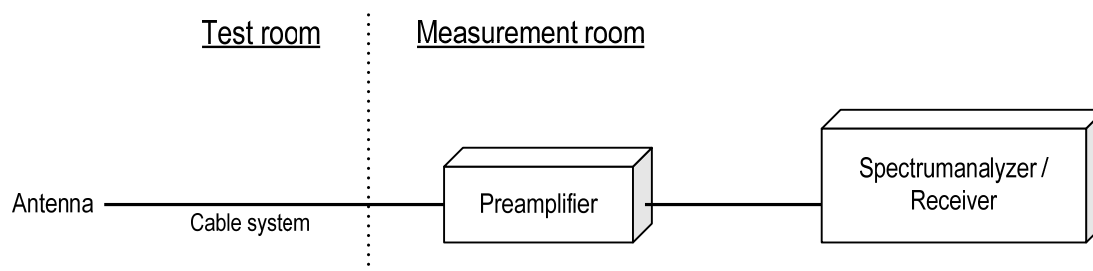

5.2 Calculation method

[9kHz to 150kHz]

Emission level = Reading + (Ant. factor + Cable system loss)

Margin = Limit – Emission level

[150kHz to 1000MHz]

Emission level = Reading + (Ant. factor + Cable system loss – Amp. Gain)

Margin = Limit – Emission level

5.3 Limit

Frequency [MHz]	Field strength		Distance [m]
	[uV/m]	[dBuV/m]	
0.009-0.490	2400 / F [kHz]	20logE [uV/m]	300
0.490-1.705	24000 / F [kHz]	20logE [uV/m]	30
1.705-30	30	29.5	30
30-88	100	40.0	3
88-216	150	43.5	3
216-960	200	46.0	3
Above 960	300	54.0	3

Frequency [MHz]	Limit [dBuV/m]	Distance [m]
30-300	30	10
300-1000	37	10

Note:

1. The lower limit shall apply at the transition frequencies.
2. Emission level [dBuV/m] = 20log Emission [uV/m]
3. Measurements were corrected to 30m using $40\log(3/30) = -40.0\text{dB}$
4. CISPR 22 limit was applied radiated emission measurements as prescribed in FCC Part 15 section 15.109(g).



Zacta

Date : Apr. 2, 2013 Test personnel :
 Temperature : 24.3 [°C]
 Humidity : 17.3 [%] Tested by :
 Test place : 10m Semi-anechoic chamber Tsuyoshi Okumura

[30MHz to 1000MHz]**Pen: LP-180**

No.	Frequency [MHz]	(P)	Reading QP [dB(μV)]	c. f [dB(1/m)]	Result QP [dB(μV/m)]	Limit QP [dB(μV/m)]	Margin QP [dB]	Height [cm]	Angle [°]
1	48.685	H	27.8	-11.0	16.8	30.0	13.2	400.0	332.0
2	66.535	V	35.6	-15.3	20.3	30.0	9.7	190.0	243.0
3	96.132	H	32.3	-12.7	19.6	30.0	10.4	322.0	87.0
4	96.135	V	29.8	-12.7	17.1	30.0	12.9	100.0	294.0
5	142.483	V	26.4	-7.2	19.2	30.0	10.8	100.0	228.0
6	142.496	H	24.6	-7.2	17.4	30.0	12.6	400.0	256.0
7	144.201	H	27.8	-7.0	20.8	30.0	9.2	400.0	88.0
8	144.206	V	29.2	-7.0	22.2	30.0	7.8	100.0	237.0
9	172.483	V	26.4	-5.7	20.7	30.0	9.3	100.0	228.0
10	299.835	V	33.1	-1.6	31.5	37.0	5.5	100.0	276.0
11	601.898	V	32.0	-4.1	27.9	37.0	9.1	234.0	225.0
12	601.898	H	28.6	-4.1	24.5	37.0	12.5	371.0	229.0
13	799.719	V	28.4	-1.7	26.7	37.0	10.3	169.0	335.0
14	832.974	V	29.8	-1.0	28.8	37.0	8.2	168.0	7.0
15	864.131	H	27.6	-0.4	27.2	37.0	9.8	111.0	179.0
16	866.323	V	25.2	-0.3	24.9	37.0	12.1	175.0	15.0

Pen: LP-180E

No.	Frequency [MHz]	(P)	Reading QP [dB(μV)]	c. f [dB(1/m)]	Result QP [dB(μV/m)]	Limit QP [dB(μV/m)]	Margin QP [dB]	Height [cm]	Angle [°]
1	37.992	H	28.3	-7.2	21.1	30.0	8.9	400.0	21.0
2	60.875	V	36.8	-14.4	22.4	30.0	7.6	148.0	165.0
3	66.538	V	36.5	-15.3	21.2	30.0	8.8	141.0	268.0
4	96.138	H	32.1	-12.7	19.4	30.0	10.6	330.0	100.0
5	96.138	V	30.0	-12.7	17.3	30.0	12.7	100.0	215.0
6	144.207	V	29.7	-7.0	22.7	30.0	7.3	160.0	186.0
7	155.988	V	23.1	-6.5	16.6	30.0	13.4	160.0	280.0
8	298.688	V	32.7	-1.7	31.0	37.0	6.0	100.0	282.0
9	432.030	H	33.6	-7.3	26.3	37.0	10.7	245.0	353.0
10	576.019	H	28.7	-4.5	24.2	37.0	12.8	203.0	249.0
11	601.909	H	28.4	-4.1	24.3	37.0	12.7	383.0	243.0
12	601.910	V	32.0	-4.1	27.9	37.0	9.1	218.0	223.0
13	799.700	V	27.9	-1.7	26.2	37.0	10.8	173.0	357.0
14	816.123	H	29.1	-1.4	27.7	37.0	9.3	100.0	66.0
15	832.740	V	29.3	-1.0	28.3	37.0	8.7	178.0	6.0
16	864.133	H	27.1	-0.4	26.7	37.0	10.3	100.0	171.0

6. AC Power Line Conducted Emissions

6.1 Measurement procedure

[FCC 15.207, IC RSS-Gen 7.2.2]

Test was applied by following conditions.

Test method	: ANSI C63.4
Frequency range	: 0.15MHz to 30MHz
Test place	: 10m Semi-anechoic chamber
EUT was placed on	: FRP table / (W)2.0m × (D)1.0m × (H)0.8m
Vertical Metal Reference Plane	: (W)2.0m × (H)2.0m 0.4m away from EUT
Test receiver setting	
- Detector	: Quasi-peak, Average
- Bandwidth	: 9kHz

EUT and peripherals are connected to 50Ω/50μH Line Impedance Stabilization Network (LISN) which are connected to reference ground plane, and are placed 80cm away from EUT. Excess of AC power cable is bundled in center.

LISN for peripheral is terminated in 50Ω.

EUT operating mode is selected to emit the maximum noise. Overall frequency range is investigated with spectrum analyzer using peak detector. Maximum emission configuration is determined by manipulating the EUT, peripherals, interconnecting cables. Then, emission measurements are performed with test receiver in above setting to each current-carrying conductor of the mains port. Sufficient time for EUT, peripherals and test equipment is provided in order for them to warm up to their normal operating condition. If the average limit is met when using a quasi-peak detector receiver, the EUT shall be deemed to meet both limits.

- Test configuration

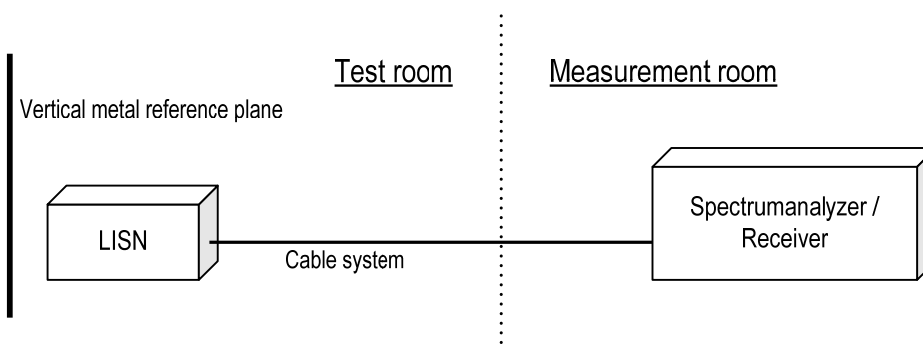

6.2 Calculation method

Emission level = Reading + (LISN. factor + Cable system loss)

Margin = Limit – Emission level

6.3 Limit

Frequency [MHz]	Limit	
	QP [dBuV]	AV [dBuV]
0.15-0.5	66-56*	56-46*
0.5-5	56	46
5-30	60	50

*: The limit decreases linearly with the logarithm of the frequency in the range 0.15MHz to 0.5MHz.



Zacta

6.3 Test data

***** CONDUCTED EMISSION at MAINS PORT *****
 << 10m semi-anechoic chamber >>

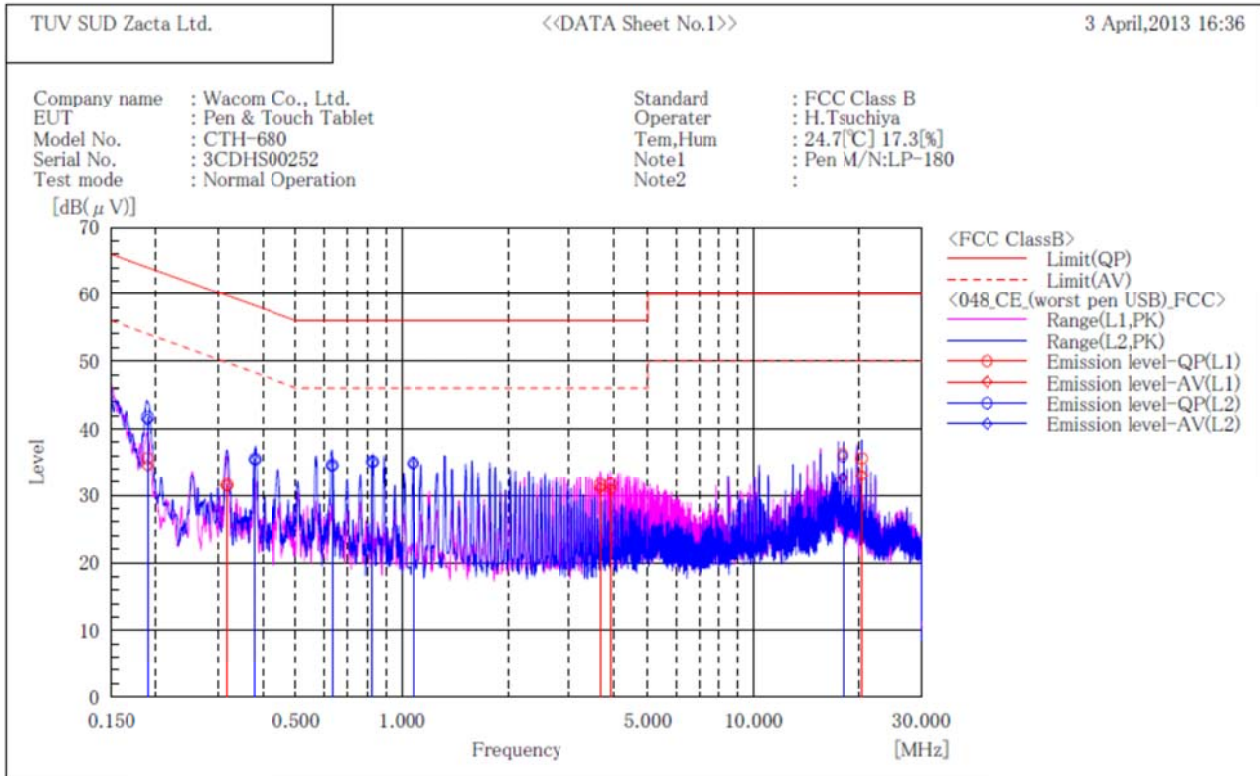

Final Result

--- L1 Phase ---

No.	Frequency	Reading QP	Reading AV	c. f	Result QP	Result AV	Limit QP	Limit AV	Margin QP	Margin AV
	[MHz]	[dB(μV)]	[dB(μV)]	[dB]	[dB(μV)]	[dB(μV)]	[dB(μV)]	[dB(μV)]	[dB]	[dB]
1	0.190	25.3	24.2	10.3	35.6	34.5	64.0	54.0	28.4	19.5
2	0.317	21.4	21.2	10.2	31.6	31.4	59.8	49.8	28.2	18.4
3	3.674	21.1	20.6	10.5	31.6	31.1	56.0	46.0	24.4	14.9
4	3.927	21.2	20.4	10.5	31.7	30.9	56.0	46.0	24.3	15.1
5	17.888	25.0	21.2	11.3	36.3	32.5	60.0	50.0	23.7	17.5
6	20.399	24.2	21.6	11.4	35.6	33.0	60.0	50.0	24.4	17.0

--- L2 Phase ---

No.	Frequency	Reading QP	Reading AV	c. f	Result QP	Result AV	Limit QP	Limit AV	Margin QP	Margin AV
	[MHz]	[dB(μV)]	[dB(μV)]	[dB]	[dB(μV)]	[dB(μV)]	[dB(μV)]	[dB(μV)]	[dB]	[dB]
1	0.190	31.5	31.1	10.3	41.8	41.4	64.0	54.0	22.2	12.6
2	0.380	25.3	25.2	10.2	35.5	35.4	58.3	48.3	22.8	12.9
3	0.633	24.4	24.3	10.2	34.6	34.5	56.0	46.0	21.4	11.5
4	0.823	24.9	24.8	10.2	35.1	35.0	56.0	46.0	20.9	11.0
5	1.077	24.7	24.6	10.2	34.9	34.8	56.0	46.0	21.1	11.2
6	17.888	24.7	21.5	11.2	35.9	32.7	60.0	50.0	24.1	17.3



Zacta

***** CONDUCTED EMISSION at MAINS PORT *****
 < 10m semi-anechoic chamber >

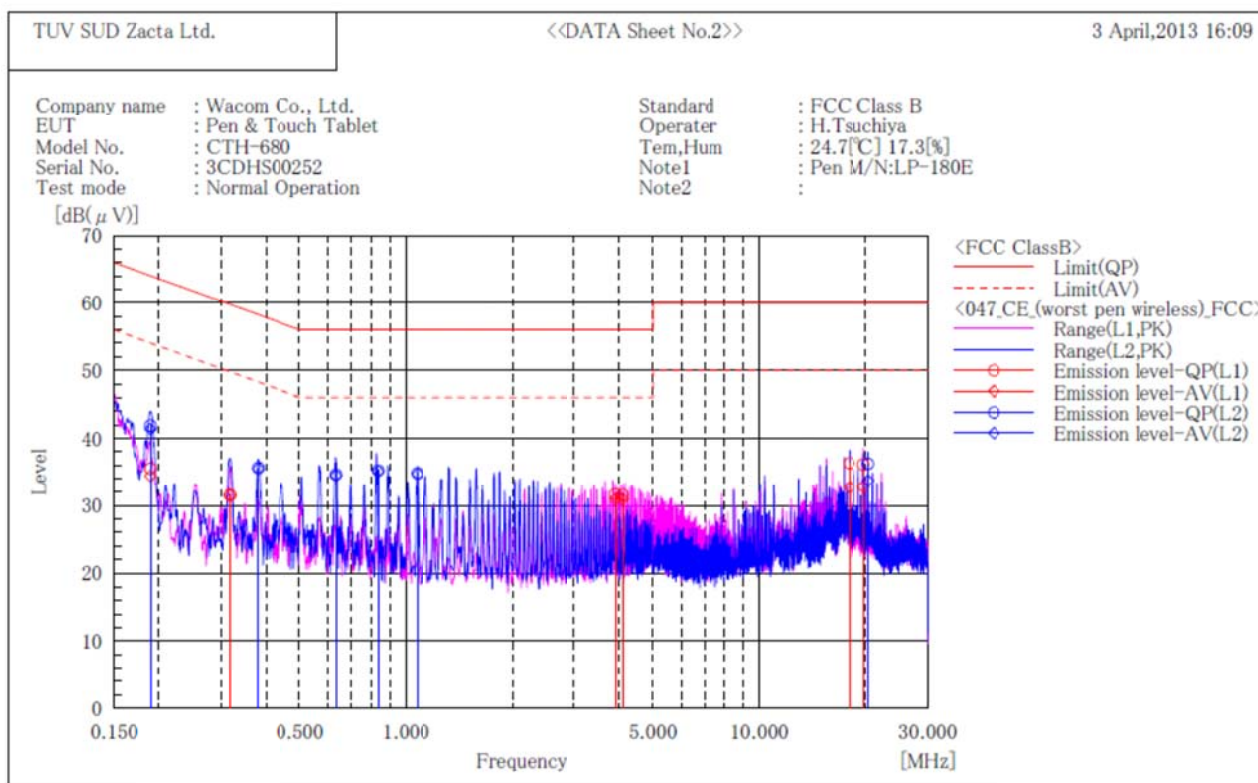

Final Result

--- L1 Phase ---

No.	Frequency [MHz]	Reading QP [dB(μV)]	Reading AV [dB(μV)]	c. f [dB]	Result QP [dB(μV)]	Result AV [dB(μV)]	Limit QP [dB(μV)]	Limit AV [dB(μV)]	Margin QP [dB]	Margin AV [dB]
1	0.190	25.2	24.1	10.3	35.5	34.4	64.0	54.0	28.5	19.6
2	0.317	21.4	21.3	10.2	31.6	31.5	59.8	49.8	28.2	18.3
3	3.926	21.2	20.5	10.5	31.7	31.0	56.0	46.0	24.3	15.0
4	4.116	21.1	20.5	10.5	31.6	31.0	56.0	46.0	24.4	15.0
5	17.888	25.0	21.4	11.3	36.3	32.7	60.0	50.0	23.7	17.3
6	19.771	24.7	21.4	11.4	36.1	32.8	60.0	50.0	23.9	17.2

--- L2 Phase ---

No.	Frequency [MHz]	Reading QP [dB(μV)]	Reading AV [dB(μV)]	c. f [dB]	Result QP [dB(μV)]	Result AV [dB(μV)]	Limit QP [dB(μV)]	Limit AV [dB(μV)]	Margin QP [dB]	Margin AV [dB]
1	0.190	31.6	31.1	10.3	41.9	41.4	64.0	54.0	22.1	12.6
2	0.380	25.4	25.3	10.2	35.6	35.5	58.3	48.3	22.7	12.8
3	0.633	24.4	24.3	10.2	34.6	34.5	56.0	46.0	21.4	11.5
4	0.832	25.0	24.9	10.2	35.2	35.1	56.0	46.0	20.8	10.9
5	1.076	24.6	24.5	10.2	34.8	34.7	56.0	46.0	21.2	11.3
6	20.398	24.8	22.3	11.4	36.2	33.7	60.0	50.0	23.8	16.3

7. Uncertainty of measurement

Expanded uncertainties stated are calculated with a coverage Factor $k=2$.

Please note that these results are not taken into account when determining compliance or non-compliance with test result.

Test item	Measurement uncertainty
Conducted emission at mains port	$\pm 3.0\text{dB}$
Radiated emission (9kHz – 30MHz)	$\pm 4.4\text{dB}$
Radiated emission (30MHz – 1000MHz)	$\pm 4.5\text{dB}$
Radiated emission (1000MHz – 26GHz)	$\pm 3.9\text{dB}$

8. Laboratory description

1. Location:

TÜV SÜD Zacta Ltd. Yonezawa Testing Center
4149-7 Hachimanpara 5-chome Yonezawa-shi Yamagata 992-1128 Japan
Phone: +81-238-28-2880 Fax: +81-238-28-2888

2. Facility filing information:

1) NVLAP accreditation: NVLAP Lab. code: 200306-0

2) VLAC accreditation: Lab. code: VLAC-013

Site name	Radiated emission	Conducted emission for mains port	Conducted emission for telecom port	Radiated emission (CMAD)	Expiry Date
10m Semi-anechoic chamber	VLAC-013	VLAC-013	VLAC-013	VLAC-013	Jul. 3, 2013
3m Semi-anechoic chamber				-	
Shielded room No.1	-	VLAC-013	-	-	

3) FCC filing:

Site name	Registration Number	Expiry Date
Site 2	91065	Oct.31, 2014
Site 3		
10m Semi-anechoic chamber	540072	Jan. 9, 2016
3m Semi-anechoic chamber		
Shielded room No.1		

4) Industry Canada Oats site filing:

Site name	Sites on file: Oats 3m/10m	Expiry Date
Site 2	4224A-2	Jan. 23, 2015
Site 3	4224A-3	
10m Semi-anechoic chamber	4224A-4	
3m Semi-anechoic chamber	4224A-5	

5) VCCI site filing:

Site name	Radiated emission	Conducted emission for mains port	Expiry Date	Conducted emission for telecom port	Expiry Date
Site 2	R-137	C-133	Nov. 16, 2014	T-1221	Nov. 28, 2014
Site 3	R-138	C-134		T-1222	
10m Semi-anechoic chamber	R-2480	C-2722	Jul. 3, 2013	T-1474	Jul. 3, 2013
	G-81	-		-	-
3m Semi-anechoic chamber	R-2481	C-2723		T-1475	Jul. 3, 2013
	G-82	-		-	-
Shielded room No.1	-	C-2724		T-1476	Jul. 3, 2013

6) TÜV SÜD PS authorization:

Authorized as an EMC test laboratory

7) TÜV Rheinland authorization:

Authorized as an EMC test laboratory

Appendix A. Test equipment

Radiated emission [Testing below 30Hz]

Equipment	Company	Model No.	Serial No.	Cal. due	Cal. date
EMI Receiver	ROHDE&SCHWARZ	ECSI	100764	Jul. 2013	Jul. 6, 2012
Preamplifier	ANRITSU	MH648A	M96057	Jun. 2013	Jun. 12, 2012
Loop antenna	ROHDE&SCHWARZ	HFH2-Z2	892246/010	Sep. 2013	Sep. 14, 2012
Microwave cable	SUHNER	SUCOFLEX104/9m	346316/4	Oct. 2013	Oct. 6, 2012
		SUCOFLEX104/1m	322084/4	Oct. 2013	Oct. 6, 2012
		SUCOFLEX104/1.5m	317226/4	Oct. 2013	Oct. 6, 2012
		SUCOFLEX104/7m	41625/6	Oct. 2013	Oct. 6, 2012
PC	DELL	DIMENSION E521	75465BX	N/A	N/A
Software	TOYO Corporation	EP5/RE-AJ	0611193/V5.3.61	N/A	N/A
3m Semi-anechoic chamber	TOKIN	N/A	N/A (9002-NSA)	May 2013	May 19, 2012

[Testing above 30MHz]

Equipment	Company	Model No.	Serial No.	Cal. due	Cal. date
EMI Receiver	ROHDE&SCHWARZ	ECSI	100765	Jul. 2013	Jul. 28, 2012
Preamplifier	ANRITSU	MH648A	M96067	Jun. 2013	Jun. 12, 2012
Biconical antenna	Schwarzbeck	VHA9103/BBA9106	2550	May 2013	May 30, 2012
Log periodic antenna	Schwarzbeck	UHALP9108A	0561	May 2013	May 30, 2012
Attenuator	TME	CFA-01NPJ-6	N/A (S273)	Jun. 2013	Jun. 12, 2012
Attenuator	TME	CFA-01NPJ-3	N/A (S270)	Jun. 2013	Jun. 12, 2012
Microwave cable	SUHNER	SUCOFLEX104/9m	346315/4	Sep. 2013	Sep. 14, 2012
		SUCOFLEX104/1m	322085/4	Oct. 2013	Oct. 6, 2012
		SUCOFLEX104/1.5m	317222/4	Oct. 2013	Oct. 6, 2012
		SUCOFLEX106/12m	41624/6	Oct. 2013	Oct. 6, 2012
PC	HP	dc7800small	JPA7450FPJ	N/A	N/A
Software	TOYO Corporation	EP5/RE-AJ	0611193/V5.3.61	N/A	N/A
10m Semi-anechoic chamber	TOKIN	N/A	N/A (9002-NSA)	May 201H	May 20, 2012

Conducted emission at mains port

Equipment	Company	Model No.	Serial No.	Cal. due	Cal. date
EMI Receiver	ROHDE&SCHWARZ	ECSI	100765	Jul. 2013	Jul. 28, 2012
Attenuator	TYC	BA-PJ-10	N/A (S344)	Apr. 2013	Apr. 26, 2012
Line impedance stabilization network for EUT	Kyoritsu Electrical Works, Ltd.	KNW-407F	8-2003-1	Mar. 2014	Mar. 12, 2013
Line impedance stabilization network for peripheral	Kyoritsu Electrical Works, Ltd.	KNW-242F	8-1973-1	Jun. 2013	Jun. 13, 2012
Coaxial cable	FUJIKURA	5D-2W/4m	N/A (S349)	Feb. 2014	Feb. 4, 2013
Microwave cable	SUHNER	SUCOFLEX104/1.5m	317222/4	Oct. 2013	Oct. 6, 2012
Coaxial cable	SUHNER	RG214/U/25m	N/A (S191)	Feb. 2014	Feb. 4, 2013
50Ω terminator	SUHNER	65-BNC-50-0-7	N/A (S054)	Mar. 2014	Mar. 5, 2013
PC	HP	dc7800small	JPA7450FPJ	N/A	N/A
10m Semi-anechoic chamber	TOKIN	N/A	N/A (9002-NSA)	May 201H	May 20, 201G