

FCC Test Report

Report No.: RF160630E02-1

FCC ID: HV4CDS810

Model No.: CDS-810

Received Date: June 30, 2016

Test Date: July 04 to 14, 2016

Issued Date: Aug. 01, 2016

Applicant: Wacom Co., Ltd.

Address: 2-510-1 Toyonodai, Kazo-shi, Saitama 349-1148 Japan

Issued By: Bureau Veritas Consumer Products Services (H.K.) Ltd., Taoyuan Branch
Hsin Chu Laboratory

Lab Address: E-2, No.1, Li Hsin 1st Road, Hsinchu Science Park, Hsinchu City 300,
Taiwan R.O.C.

Test Location (1): E-2, No.1, Li Hsin 1st Road, Hsinchu Science Park, Hsinchu City 300,
Taiwan R.O.C.

Test Location (2): No. 49, Ln. 206, Wende Rd., Shangshan Tsuen, Chiung Lin Hsiang, Hsin
Chu Hsien 307, Taiwan R.O.C.



This report is for your exclusive use. Any copying or replication of this report to or for any other person or entity, or use of our name or trademark, is permitted only with our prior written permission. This report sets forth our findings solely with respect to the test samples identified herein. The results set forth in this report are not indicative or representative of the quality or characteristics of the lot from which a test sample was taken or any similar or identical product unless specifically and expressly noted. Our report includes all of the tests requested by you and the results thereof based upon the information that you provided to us. You have 60 days from date of issuance of this report to notify us of any material error or omission caused by our negligence, provided, however, that such notice shall be in writing and shall specifically address the issue you wish to raise. A failure to raise such issue within the prescribed time shall constitute your unqualified acceptance of the completeness of this report, the tests conducted and the correctness of the report contents. Unless specific mention, the uncertainty of measurement has been explicitly taken into account to declare the compliance or non-compliance to the specification. The report must not be used by the client to claim product certification, approval, or endorsement by TAF or any government agencies.

Table of Contents

Release Control Record	3
1 Certificate of Conformity	4
2 Summary of Test Results	5
2.1 Measurement Uncertainty	5
2.2 Modification Record	5
3 General Information	6
3.1 General Description of EUT	6
3.2 Description of Test Modes	7
3.2.1 Test Mode Applicability and Tested Channel Detail	8
3.3 Description of Support Units	9
3.3.1 Configuration of System under Test	10
3.4 General Description of Applied Standards	11
4 Test Types and Results	12
4.1 Radiated Emission Measurement	12
4.1.1 Limits of Radiated Emission Measurement	12
4.1.2 Test Instruments	13
4.1.3 Test Procedures	14
4.1.4 Deviation from Test Standard	14
4.1.5 Test Setup	15
4.1.6 EUT Operating Conditions	15
4.1.7 Test Results	16
4.1.8 Test Results (Spectrum Bandwidth)	18
4.2 Conducted Emission Measurement	19
4.2.1 Limits of Conducted Emission Measurement	19
4.2.2 Test Instruments	19
4.2.3 Test Procedures	20
4.2.4 Deviation from Test Standard	20
4.2.5 Test Setup	20
4.2.6 EUT Operating Conditions	20
4.2.7 Test Results (Mode 1)	21
4.2.8 Test Results (Mode 2)	23
5 Pictures of Test Arrangements	25
Appendix – Information on the Testing Laboratories	26

Release Control Record

Issue No.	Description	Date Issued
RF160630E02-1	Original release.	Aug. 01, 2016

1 Certificate of Conformity

Product: Digital Notepad

Brand: Wacom

Model No.: CDS-810

Sample Status: ENGINEERING SAMPLE

Applicant: Wacom Co., Ltd.

Test Date: July 04 to 14, 2016

Standards: 47 CFR FCC Part 15, Subpart C (Section 15.209)
ANSI C63.10: 2013

The above equipment has been tested by **Bureau Veritas Consumer Products Services (H.K.) Ltd., Taoyuan Branch**, and found compliance with the requirement of the above standards. The test record, data evaluation & Equipment Under Test (EUT) configurations represented herein are true and accurate accounts of the measurements of the sample's EMC characteristics under the conditions specified in this report.

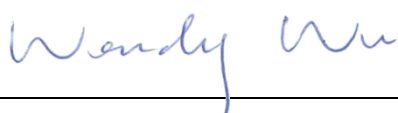
Prepared by :  _____, **Date:** Aug. 01, 2016
Wendy Wu / Specialist

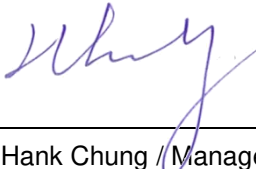
Technical Acceptance Responsible for RF :  _____, **Date:** Aug. 01, 2016
Hank Chung / Manager

Approved by :  _____, **Date:** Aug. 01, 2016
May Chen / Manager

2 Summary of Test Results

47 CFR FCC Part 15, Subpart C (SECTION 15.209)			
FCC Clause	Test Item	Result	Remarks
15.207	AC Power Conducted Emission	PASS	Meet the requirement of limit. Minimum passing margin is -10.36dB at 0.56016MHz.
15.209	Radiated Emission Test	PASS	Meet the requirement of limit. Minimum passing margin is -5.5dB at 30.02MHz.
15.203	Antenna Requirement	PASS	No antenna connector is used.

2.1 Measurement Uncertainty

Where relevant, the following measurement uncertainty levels have been estimated for tests performed on the EUT as specified in CISPR 16-4-2:

Measurement	Frequency	Expanded Uncertainty (k=2) (\pm)
Conducted Emissions at mains ports	150kHz ~ 30MHz	1.83 dB
Radiated Emissions up to 1 GHz	30MHz ~ 1GHz	5.43 dB

2.2 Modification Record

There were no modifications required for compliance.

3.2 Description of Test Modes

One channel was provided to this EUT:

Channel	FREQ. (kHz)
1	562.5

3.2.1 Test Mode Applicability and Tested Channel Detail

EUT CONFIGURE MODE	APPLICABLE TO		DESCRIPTION
	RE	PLC	
1	√	√	With adapter
2	-	√	With Notebook computer

Where **RE \geq 1G**: Radiated Emission above 1GHz
PLC: Power Line Conducted Emission
DT: Deactivation Time measurement

RE $<$ 1G: Radiated Emission below 1GHz
EB: 20dB Bandwidth measurement

NOTE: 1. The EUT had been pre-tested on the positioned of each 3 axis. The worst case was found when positioned on **Y-plane**.
2. "-" means no effect.

Radiated Emission Test:

- Pre-Scan has been conducted to determine the worst-case mode from all possible combinations between available modulations, data rates and antenna ports (if EUT with antenna diversity architecture).
- Following channel(s) was (were) selected for the final test as listed below.

TESTED CHANNEL	FREQUENCY
1	562.5 kHz

Power Line Conducted Emission Test:

- Pre-Scan has been conducted to determine the worst-case mode from all possible combinations between available modulations, data rates and antenna ports (if EUT with antenna diversity architecture).
- Following channel(s) was (were) selected for the final test as listed below.

TESTED CHANNEL	FREQUENCY
1	562.5 kHz

TEST CONDITION:

Applicable To	Environmental Conditions	Input Power	Tested By	Test Location
RE	25deg. C, 72%RH	120Vac, 60Hz	Andy Ho	2
PLC	23deg. C, 60%RH	120Vac, 60Hz	Arthur Yang	2

3.3 Description of Support Units

The EUT has been tested as an independent unit together with other necessary accessories or support units. The following support units or accessories were used to form a representative test configuration during the tests.

ID	Product	Brand	Model No.	Serial No.	FCC ID	Remarks
A.	USB Adapter	ASUS	EXA1205UA	NA	NA	Provided by Lab
B.	Notebook Computer	DELL	E6440	H7LYQ32	FCC DoC	Provided by Lab

Note:

1. All power cords of the above support units are non-shielded (1.8m).

ID	Descriptions	Qty.	Length (m)	Shielding (Yes/No)	Cores (Qty.)	Remarks
1.	USB to Micro USB cable	1	1	No	0	Supplied by client

3.3.1 Configuration of System under Test

Adapter Mode:

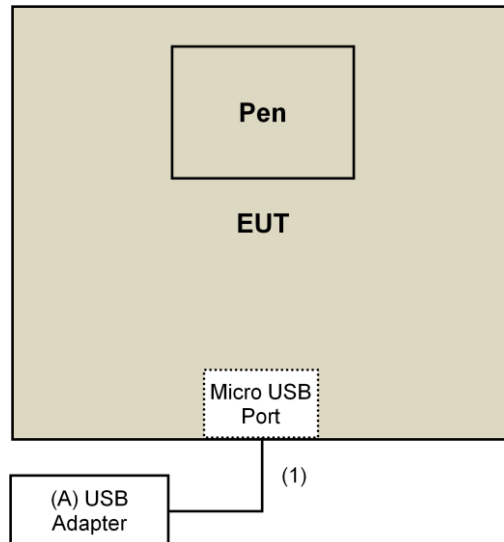

Notebook Computer Mode:

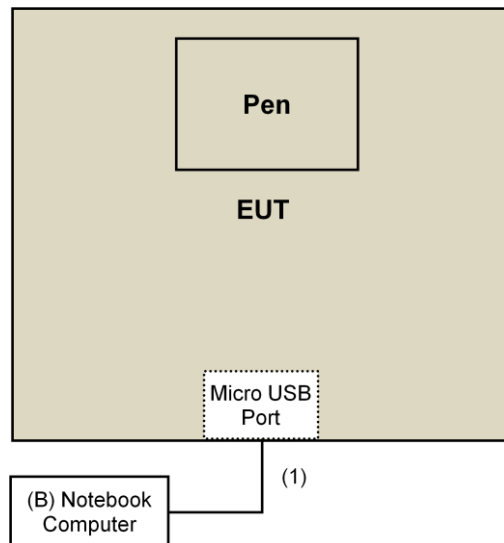

3.4 General Description of Applied Standards

The EUT is a RF Product. According to the specifications of the manufacturer, it must comply with the requirements of the following standards:

FCC Part 15, Subpart C (15.209)

ANSI C63.10- 2013

All test items have been performed and recorded as per the above standards.

NOTE: The EUT has been verified to comply with the requirements of FCC Part 15, Subpart B, Class B (DoC).
The test report has been issued separately.

4 Test Types and Results

4.1 Radiated Emission Measurement

4.1.1 Limits of Radiated Emission Measurement

Frequencies (MHz)	Field Strength (microvolts/meter)	Measurement Distance (meters)
0.009 ~ 0.490	2400/F(kHz)	300
0.490 ~ 1.705	24000/F(kHz)	30
1.705 ~ 30.0	30	30
30 ~ 88	100	3
88 ~ 216	150	3
216 ~ 960	200	3
Above 960	500	3

NOTE:

1. The lower limit shall apply at the transition frequencies.
2. Emission level (dBuV/m) = 20 log Emission level (uV/m).
3. For frequencies above 1000MHz, the field strength limits are based on average detector, however, the peak field strength of any emission shall not exceed the maximum permitted average limits, specified above by more than 20dB under any condition of modulation.

4.1.2 Test Instruments

DESCRIPTION & MANUFACTURER	MODEL NO.	SERIAL NO.	CALIBRATED DATE	CALIBRATED UNTIL
Test Receiver Agilent	N9038A	MY51210202	Dec. 16, 2015	Dec. 15, 2016
Pre-Amplifier ^(*) EMCI	EMC001340	980142	Jan. 20, 2016	Jan. 19, 2018
Loop Antenna(*) Electro-Metrics	EM-6879	264	Dec. 16, 2014	Dec. 15, 2016
RF Cable	NA	LOOPCAB-001 LOOPCAB-002	Jan. 18, 2016	Jan. 17, 2017
Pre-Amplifier Mini-Circuits	ZFL-1000VH2 B	AMP-ZFL-04	Nov. 11, 2015	Nov. 10, 2016
Trilog Broadband Antenna SCHWARZBECK	VULB 9168	9168-361	Jan. 07, 2016	Jan. 06, 2017
RF Cable	8D-FB	CHHCAB-001-1	Oct. 04, 2015	Oct. 03, 2016
		CHHCAB-001-2		
	RF-141	CHHCAB-004	Oct. 04, 2015	Oct. 03, 2016
Software	ADT_Radiated _V8.7.07	NA	NA	NA
Antenna Tower & Turn Table CT	CM100	NA	NA	NA

1. The calibration interval of the above test instruments is 12 months and the calibrations are traceable to NML/ROC and NIST/USA.
2. *The calibration interval of the above test instruments is 24 months and the calibrations are traceable to NML/ROC and NIST/USA.
3. The test was performed in 966 Chamber No. H.
4. The FCC Site Registration No. is 797305.
5. The CANADA Site Registration No. is IC 7450H-3.
6. Loop antenna was used for all emissions below 30 MHz.
7. Tested Date: June 05 to 06, 2016

4.1.3 Test Procedures

For Radiated emission below 30MHz

- a. The EUT was placed on the top of a rotating table 0.8 meters above the ground at a 3 meter chamber room. The table was rotated 360 degrees to determine the position of the highest radiation.
- b. The EUT was set 3 meters away from the interference-receiving antenna. The height of antenna is 1 meter above the ground.
- c. Both open and close axes of the antenna are set to make the measurement.
- d. For each suspected emission, the EUT was arranged to its worst case and the rotatable table was turned from 0 degrees to 360 degrees to find the maximum reading.
- e. The test-receiver system was set to Quasi-Peak Detect Function and Specified Bandwidth with Maximum Hold Mode.

NOTE: 1. The resolution bandwidth and video bandwidth of test receiver/spectrum analyzer is 200Hz at frequency below 150kHz.
2. The resolution bandwidth and video bandwidth of test receiver/spectrum analyzer is 9kHz at frequency 150kHz~ 30MHz.

For Radiated emission 30~1000MHz

- a. The EUT was placed on the top of a rotating table 0.8 meters above the ground at a 3 meter chamber room. The table was rotated 360 degrees to determine the position of the highest radiation.
- b. The EUT was set 3 meters away from the interference-receiving antenna, which was mounted on the top of a variable-height antenna tower.
- c. The height of antenna is varied from one meter to four meters above the ground to determine the maximum value of the field strength. Both horizontal and vertical polarizations of the antenna are set to make the measurement.
- d. For each suspected emission, the EUT was arranged to its worst case and then the antenna was tuned to heights from 1 meter to 4 meters and the rotatable table was turned from 0 degrees to 360 degrees to find the maximum reading.
- e. The test-receiver system was set to Quasi-Peak Detect Function and Specified Bandwidth with Maximum Hold Mode.

NOTE: The resolution bandwidth and video bandwidth of test receiver/spectrum analyzer is 120kHz for Quasi-peak detection (QP) at frequency 30MHz ~ 1GHz.

4.1.4 Deviation from Test Standard

No deviation.

4.1.5 Test Setup

<Frequency Range 9 kHz ~ 30 MHz >

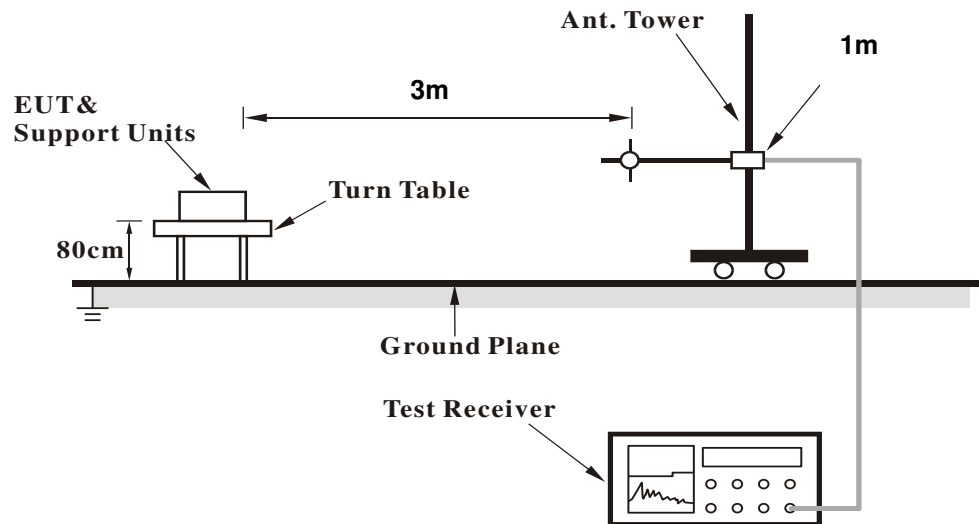

<Frequency Range 30-1000MHz >

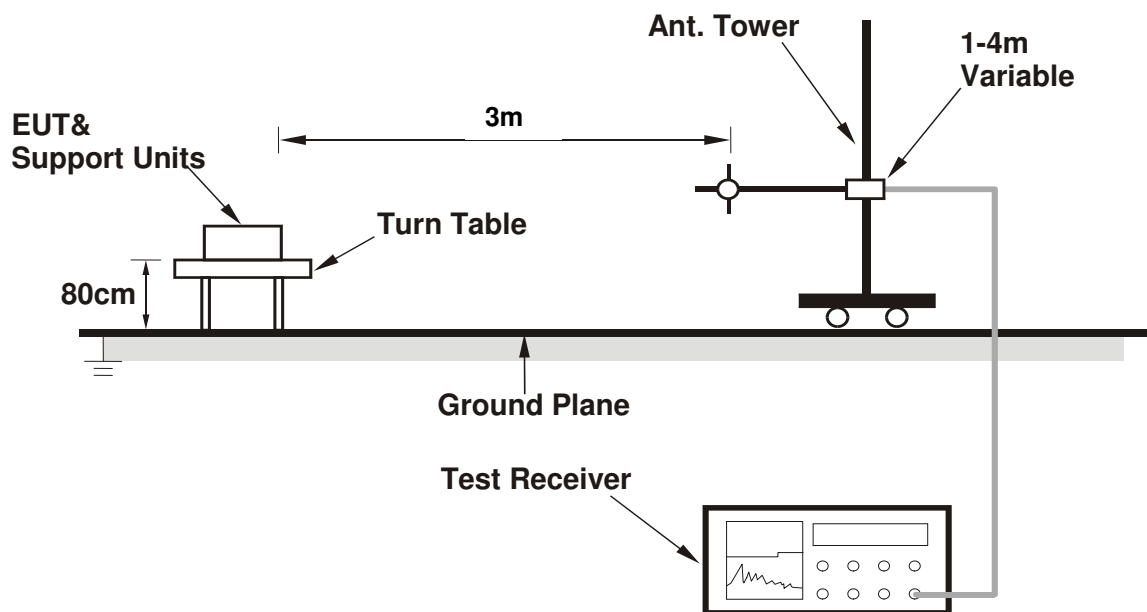

For the actual test configuration, please refer to the attached file (Test Setup Photo).

4.1.6 EUT Operating Conditions

- Placed the EUT on the testing table.
- Set the EUT under transmission condition continuously at specific channel frequency.

4.1.7 Test Results

CHANNEL	Channel 1	DETECTOR FUNCTION	Quasi-Peak (QP)
FREQUENCY RANGE	9 kHz ~ 30 MHz		

ANTENNA POLARITY & TEST DISTANCE: LOOP ANTENNA OPEN AT 3 M								
NO.	FREQ. (MHz)	EMISSION LEVEL (dBuV/m)	LIMIT (dBuV/m)	MARGIN (dB)	ANTENNA HEIGHT (m)	TABLE ANGLE (Degree)	RAW VALUE (dBuV)	CORRECTION FACTOR (dB/m)
1	0.5625	37.4 QP	72.6	-35.2	1.00	328	33.3	4.1
2	3.2345	24.1 QP	69.5	-45.4	1.00	214	26.9	-2.8
3	15.5578	38.1 QP	69.5	-31.4	1.00	107	41.7	-3.6
4	21.6655	39.7 QP	69.5	-29.8	1.00	352	43.9	-4.2
5	23.1306	45.8 QP	69.5	-23.7	1.00	230	49.5	-3.7
6	23.9628	46.7 QP	69.5	-22.8	1.00	198	50.3	-3.6
7	26.9994	47.1 QP	69.5	-22.4	1.00	225	49.9	-2.8
ANTENNA POLARITY & TEST DISTANCE: LOOP ANTENNA CLOSE AT 3 M								
NO.	FREQ. (MHz)	EMISSION LEVEL (dBuV/m)	LIMIT (dBuV/m)	MARGIN (dB)	ANTENNA HEIGHT (m)	TABLE ANGLE (Degree)	RAW VALUE (dBuV)	CORRECTION FACTOR (dB/m)
1	0.5625	33.4 QP	72.6	-39.2	1.00	244	29.3	4.1
2	1.3134	28.9 QP	65.2	-36.3	1.00	360	28.6	0.3
3	23.1306	37.6 QP	69.5	-31.9	1.00	34	41.3	-3.7
4	24.0018	38.2 QP	69.5	-31.3	1.00	154	41.8	-3.6
5	26.9994	39.3 QP	69.5	-30.2	1.00	193	42.1	-2.8
6	29.2037	36.3 QP	69.5	-33.2	1.00	315	38.8	-2.5

REMARKS:

1. Emission Level(dBuV/m) = Raw Value(dBuV) + Correction Factor(dB/m)
2. Correction Factor(dB/m) = Antenna Factor(dB/m) + Cable Factor(dB) – Pre-Amplifier Factor(dB)
3. The other emission levels were very low against the limit.
4. Margin value = Emission Level – Limit value
5. Above limits have been translated by the formula

The measured field strength was extrapolated to distance 30 meters, using the formula that the limit of field strength varies as the inverse distance square (40dB per decade of distance)

Example:

24000/562.5kHz	=42.6 uV/m	30m
	=32.6 dBuV/m	30m
	=32.6 dBuV/m+20log(30/3)^2	3m
	=72.6 dBuV/m	3m

CHANNEL	Channel 1	DETECTOR FUNCTION	Quasi-Peak (QP)
FREQUENCY RANGE	30MHz ~ 1GHz		

ANTENNA POLARITY & TEST DISTANCE: HORIZONTAL AT 3 M

NO.	FREQ. (MHz)	EMISSION LEVEL (dBuV/m)	LIMIT (dBuV/m)	MARGIN (dB)	ANTENNA HEIGHT (m)	TABLE ANGLE (Degree)	RAW VALUE (dBuV)	CORRECTION FACTOR (dB/m)
1	168.01	28.5 QP	43.5	-15.0	1.50 H	121	36.7	-8.2
2	184.01	27.8 QP	43.5	-15.7	1.50 H	86	37.6	-9.8
3	232.00	29.5 QP	46.0	-16.5	1.00 H	69	39.3	-9.8
4	264.01	27.7 QP	46.0	-18.3	1.00 H	69	35.9	-8.2
5	330.00	26.6 QP	46.0	-19.4	2.00 H	129	32.1	-5.5
6	729.49	33.4 QP	46.0	-12.6	1.00 H	280	30.6	2.8

ANTENNA POLARITY & TEST DISTANCE: VERTICAL AT 3 M

NO.	FREQ. (MHz)	EMISSION LEVEL (dBuV/m)	LIMIT (dBuV/m)	MARGIN (dB)	ANTENNA HEIGHT (m)	TABLE ANGLE (Degree)	RAW VALUE (dBuV)	CORRECTION FACTOR (dB/m)
1	30.02	34.5 QP	40.0	-5.5	1.50 V	128	43.8	-9.3
2	88.20	26.0 QP	43.5	-17.5	1.50 V	150	39.9	-13.9
3	184.01	30.5 QP	43.5	-13.0	1.00 V	104	40.3	-9.8
4	330.00	31.8 QP	46.0	-14.2	1.00 V	185	37.3	-5.5
5	585.47	25.9 QP	46.0	-20.1	1.00 V	276	25.7	0.2
6	939.35	31.8 QP	46.0	-14.2	1.00 V	0	25.1	6.7

REMARKS:

1. Emission Level(dBuV/m) = Raw Value(dBuV) + Correction Factor(dB/m)
2. Correction Factor(dB/m) = Antenna Factor(dB/m) + Cable Factor(dB) – Pre-Amplifier Factor(dB)
3. The other emission levels were very low against the limit.
4. Margin value = Emission Level – Limit value

4.1.8 Test Results (Spectrum Bandwidth)

BANDWIDTH: 0.174MHz

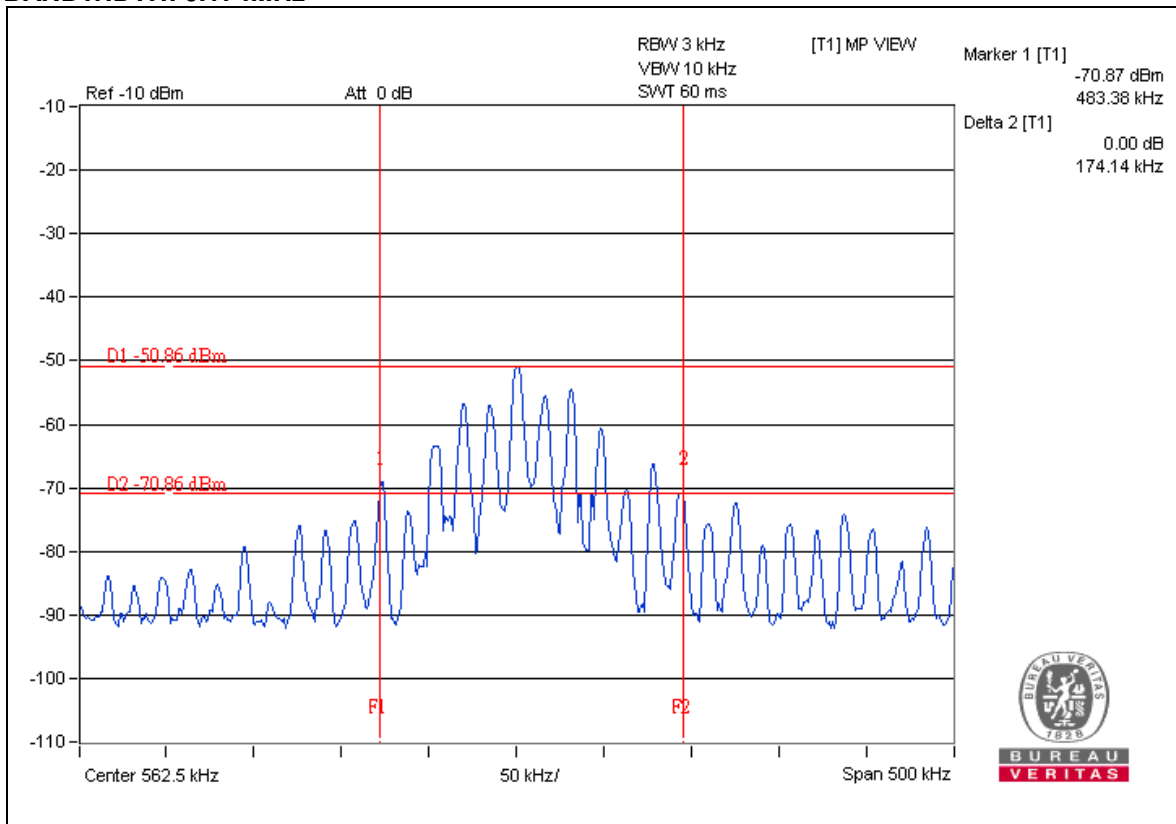

4.2 Conducted Emission Measurement

4.2.1 Limits of Conducted Emission Measurement

Frequency (MHz)	Conducted Limit (dBuV)	
	Quasi-peak	Average
0.15 - 0.5	66 - 56	56 - 46
0.50 - 5.0	56	46
5.0 - 30.0	60	50

Note: 1. The lower limit shall apply at the transition frequencies.

2. The limit decreases in line with the logarithm of the frequency in the range of 0.15 to 0.50MHz.

3. All emanations from a class A/B digital device or system, including any network of conductors and apparatus connected thereto, shall not exceed the level of field strengths specified above.

4.2.2 Test Instruments

DESCRIPTION & MANUFACTURER	MODEL NO.	SERIAL NO.	CALIBRATED DATE	CALIBRATED UNTIL
Test Receiver R&S	ESCS 30	100375	May 09, 2016	May 08, 2017
Line-Impedance Stabilization Network (for EUT) SCHWARZBECK	NSLK-8127	8127-522	Sep. 01, 2015	Aug. 31, 2016
Line-Impedance Stabilization Network (for Peripheral) R&S	ENV216	100072	June 13, 2016	June 12, 2017
RF Cable	5D-FB	COCCAB-001	Mar. 08, 2016	Mar. 07, 2017
10 dB PAD Mini-Circuits	HAT-10+	CONATT-003	Sep. 14, 2015	Sep. 13, 2016
50 ohms Terminator	N/A	EMC-03	Sep. 23, 2015	Sep. 22, 2016
50 ohms Terminator	N/A	EMC-02	Oct. 01, 2015	Sep. 30, 2016
Software BVADT	BVADT_Cond_ V7.3.7.3	NA	NA	NA

Note:

1. The calibration interval of the above test instruments are 12 months and the calibrations are traceable to NML/ROC and NIST/USA.
2. The test was performed in Shielded Room No. C.
3. The VCCI Con C Registration No. is C-3611.
4. Tested Date: July 11, 2016

4.2.3 Test Procedures

- The EUT was placed 0.4 meters from the conducting wall of the shielded room with EUT being connected to the power mains through a line impedance stabilization network (LISN). Other support units were connected to the power mains through another LISN. The two LISNs provide 50 ohm/ 50uH of coupling impedance for the measuring instrument.
- Both lines of the power mains connected to the EUT were checked for maximum conducted interference.
- The frequency range from 150kHz to 30MHz was searched. Emission levels under (Limit - 20dB) was not recorded.

NOTE: The resolution bandwidth and video bandwidth of test receiver is 9kHz for quasi-peak detection (QP) and average detection (AV) at frequency 0.15MHz-30MHz.

4.2.4 Deviation from Test Standard

No deviation.

4.2.5 Test Setup

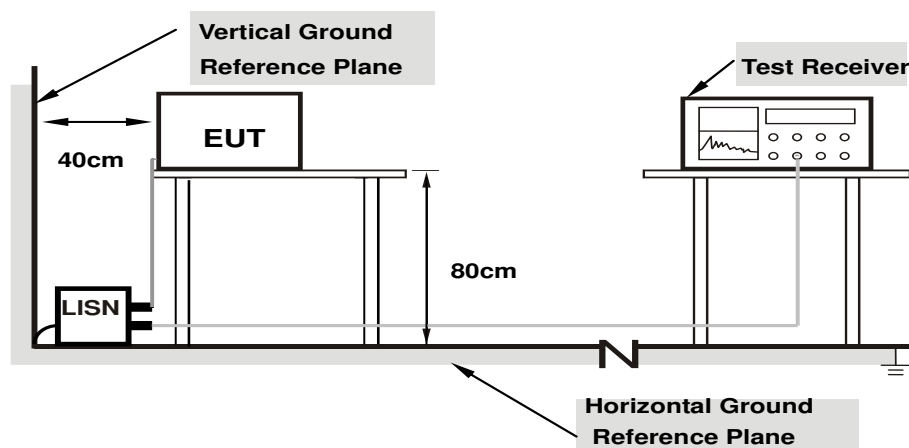

Note: 1.Support units were connected to second LISN.

For the actual test configuration, please refer to the attached file (Test Setup Photo).

4.2.6 EUT Operating Conditions

Same as 4.1.6.

4.2.7 Test Results (Mode 1)

Phase	Line (L)	Detector Function	Quasi-Peak (QP) / Average (AV)
-------	----------	-------------------	--------------------------------

No	Freq. [MHz]	Corr.	Reading Value		Emission Level		Limit		Margin	
		Factor (dB)	[dB (uV)]		[dB (uV)]		[dB (uV)]		(dB)	
			Q.P.	AV.	Q.P.	AV.	Q.P.	AV.	Q.P.	AV.
1	0.16172	10.43	39.13	33.69	49.56	44.12	65.38	55.38	-15.82	-11.26
2	0.20078	10.40	36.05	31.68	46.45	42.08	63.58	53.58	-17.13	-11.50
3	0.56016	10.42	32.83	25.22	43.25	35.64	56.00	46.00	-12.75	-10.36
4	0.95859	10.38	25.74	17.42	36.12	27.80	56.00	46.00	-19.88	-18.20
5	1.72656	10.42	23.48	15.62	33.90	26.04	56.00	46.00	-22.10	-19.96
6	12.94141	11.11	19.89	12.83	31.00	23.94	60.00	50.00	-29.00	-26.06

REMARKS:

1. Q.P. and AV. are abbreviations of quasi-peak and average individually.
2. The emission levels of other frequencies were very low against the limit.
3. Margin value = Emission level - Limit value
4. Correction factor = Insertion loss + Cable loss
5. Emission Level = Correction Factor + Reading Value.

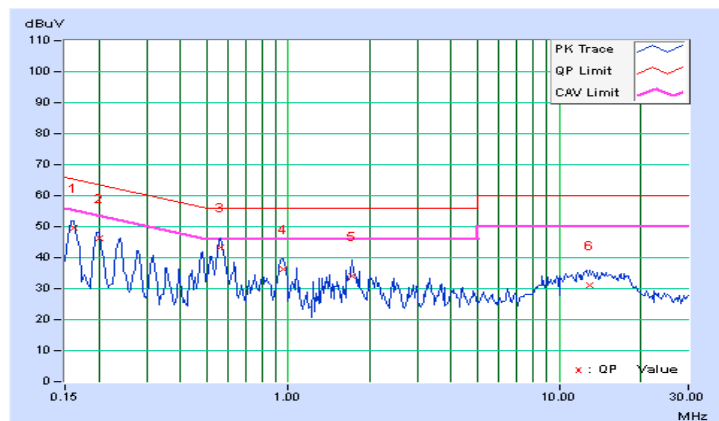

Phase	Neutral (N)	Detector Function	Quasi-Peak (QP) / Average (AV)
-------	-------------	-------------------	--------------------------------

No	Freq. [MHz]	Corr.	Reading Value		Emission Level		Limit		Margin	
		Factor (dB)	[dB (uV)]		[dB (uV)]		[dB (uV)]		(dB)	
			Q.P.	AV.	Q.P.	AV.	Q.P.	AV.	Q.P.	AV.
1	0.15781	10.45	38.51	26.98	48.96	37.43	65.58	55.58	-16.62	-18.15
2	0.20078	10.45	34.52	24.11	44.97	34.56	63.58	53.58	-18.61	-19.02
3	0.31797	10.47	25.31	17.04	35.78	27.51	59.76	49.76	-23.98	-22.25
4	0.56406	10.47	21.58	13.93	32.05	24.40	56.00	46.00	-23.95	-21.60
5	0.95469	10.43	18.57	9.97	29.00	20.40	56.00	46.00	-27.00	-25.60
6	14.27734	11.21	16.84	8.83	28.05	20.04	60.00	50.00	-31.95	-29.96

REMARKS:

1. Q.P. and AV. are abbreviations of quasi-peak and average individually.
2. The emission levels of other frequencies were very low against the limit.
3. Margin value = Emission level - Limit value
4. Correction factor = Insertion loss + Cable loss
5. Emission Level = Correction Factor + Reading Value.

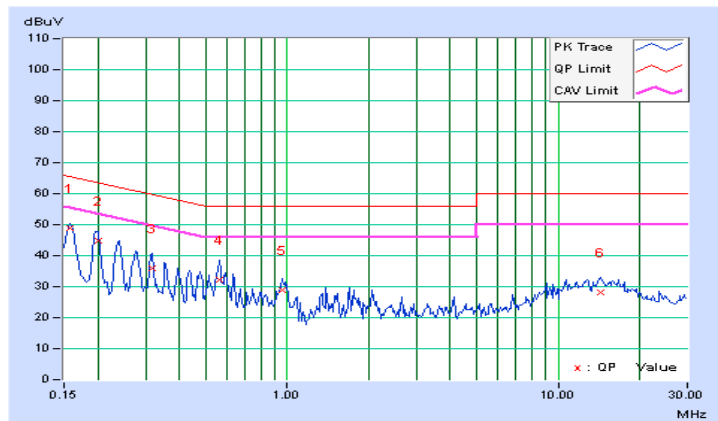

4.2.8 Test Results (Mode 2)

Phase	Line (L)	Detector Function	Quasi-Peak (QP) / Average (AV)
-------	----------	-------------------	--------------------------------

No	Freq. [MHz]	Corr. Factor	Reading Value [dB (uV)]		Emission Level [dB (uV)]		Limit [dB (uV)]		Margin (dB)	
		(dB)	Q.P.	AV.	Q.P.	AV.	Q.P.	AV.	Q.P.	AV.
	1	0.18906	10.29	32.58	19.14	42.87	29.43	64.08	54.08	-21.21
2	0.72031	10.26	23.41	7.63	33.67	17.89	56.00	46.00	-22.33	-28.11
3	2.67188	10.32	27.94	14.16	38.26	24.48	56.00	46.00	-17.74	-21.52
4	5.00000	10.45	27.98	16.64	38.43	27.09	56.00	46.00	-17.57	-18.91
5	10.10547	10.55	33.27	23.81	43.82	34.36	60.00	50.00	-16.18	-15.64
6	11.87891	10.63	30.42	21.95	41.05	32.58	60.00	50.00	-18.95	-17.42

REMARKS:

1. Q.P. and AV. are abbreviations of quasi-peak and average individually.
2. The emission levels of other frequencies were very low against the limit.
3. Margin value = Emission level - Limit value
4. Correction factor = Insertion loss + Cable loss
5. Emission Level = Correction Factor + Reading Value.

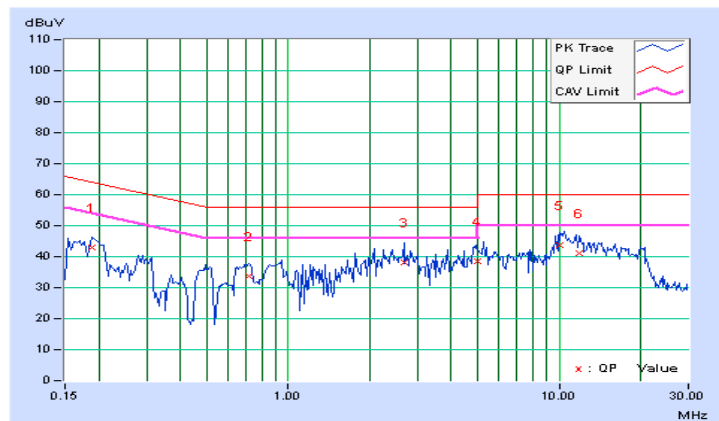

Phase	Neutral (N)	Detector Function	Quasi-Peak (QP) / Average (AV)
-------	-------------	-------------------	--------------------------------

No	Freq. [MHz]	Corr.	Reading Value		Emission Level		Limit		Margin	
		Factor	[dB (uV)]		[dB (uV)]		[dB (uV)]		(dB)	
	(dB)	Q.P.	AV.	Q.P.	AV.	Q.P.	AV.	Q.P.	AV.	
1	0.18516	10.27	32.87	18.98	43.14	29.25	64.25	54.25	-21.11	-25.00
2	0.29063	10.27	27.83	18.79	38.10	29.06	60.51	50.51	-22.41	-21.45
3	0.90781	10.23	22.36	8.55	32.59	18.78	56.00	46.00	-23.41	-27.22
4	2.13281	10.27	29.52	17.32	39.79	27.59	56.00	46.00	-16.21	-18.41
5	2.83594	10.34	26.56	15.36	36.90	25.70	56.00	46.00	-19.10	-20.30
6	9.76172	10.55	30.37	22.75	40.92	33.30	60.00	50.00	-19.08	-16.70

REMARKS:

1. Q.P. and AV. are abbreviations of quasi-peak and average individually.
2. The emission levels of other frequencies were very low against the limit.
3. Margin value = Emission level - Limit value
4. Correction factor = Insertion loss + Cable loss
5. Emission Level = Correction Factor + Reading Value.

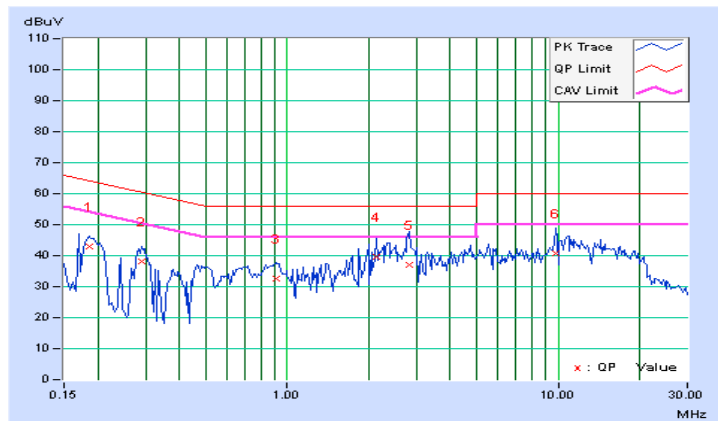

5 Pictures of Test Arrangements

Please refer to the attached file (Test Setup Photo).

Appendix – Information on the Testing Laboratories

We, Bureau Veritas Consumer Products Services (H.K.) Ltd., Taoyuan Branch, were founded in 1988 to provide our best service in EMC, Radio, Telecom and Safety consultation. Our laboratories are accredited and approved according to ISO/IEC 17025.

If you have any comments, please feel free to contact us at the following:

Linko EMC/RF Lab

Tel: 886-2-26052180

Fax: 886-2-26051924

Hsin Chu EMC/RF/Telecom Lab

Tel: 886-3-6668565

Fax: 886-3-6668323

Hwa Ya EMC/RF/Safety Lab

Tel: 886-3-3183232

Fax: 886-3-3270892

Email: service.adt@tw.bureauveritas.com

Web Site: www.bureauveritas-adt.com

The address and road map of all our labs can be found in our web site also.

--- END ---