



Excellence in Compliance Testing

Certification Exhibit

**FCC ID: HSW-XDM2140
IC: 4492A-XDM2140**

**FCC Rule Part: 15.247
IC Radio Standards Specification: RSS-210**

ACS Report Number: 08-0352 - 15C

**Manufacturer: RFM / Cirronet Inc.
Model: XDM2140**

Manual

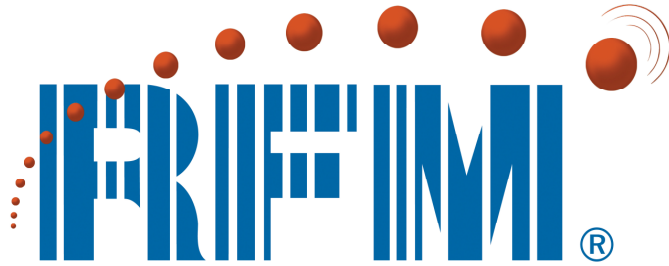

Integration Guide

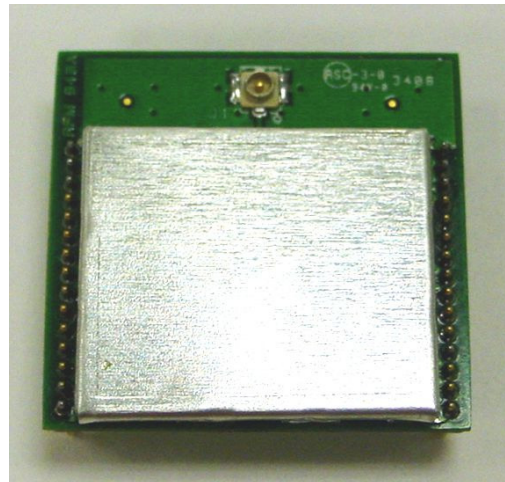

3079 Premiere Parkway, Suite 140
Duluth, GA 30097

Important Regulatory Information

Cirronet DUST Network module

FCC ID: HSW-XDM2140

IC: 4492A-XDM2140

THIS DEVICE COMPLIES WITH PART 15 OF THE FCC RULES. OPERATION IS SUBJECT TO THE FOLLOWING TWO CONDITIONS. (1) THIS DEVICE MAY NOT CAUSE HARMFUL INTERFERENCE, AND (2) THIS DEVICE MUST ACCEPT ANY INTERFERENCE RECEIVED, INCLUDING INTERFERENCE THAT MAY CAUSE UNDESIRE OPERATION.

This Class B digital apparatus complies with Canadian ICES-003.

Cet appareil numérique de la classe B est conforme à la norme NMB-003 du Canada.

FCC User Information

“NOTE: This equipment has been tested and found to comply with the limits for a Class B digital device, pursuant to Part 15 of the FCC Rules. These limits are designed to provide reasonable protection against harmful interference in a residential installation. This equipment generates, uses, and can radiate radio frequency energy and, if not installed and used in accordance with the instructions, may cause harmful interference to radio communications. However, there is no guarantee that interference will not occur in a particular installation. If this equipment does cause harmful interference to radio or television reception, which can be determined by turning the equipment off and on, the user is encouraged to try to correct the interference by one or more of the following measures:

- Reorient or relocate the receiving antenna.
- Increase the separation between the equipment and receiver.
- Connect equipment to an outlet on a circuit different in which the receiver is connected.
- Consult the dealer or an experienced radio/TV technician for help.”

Warning: Changes or modifications to this device not expressly approved by RFM Inc. could void the user's authority to operate the equipment.

RF Exposure

In accordance with FCC requirements of human exposure to radiofrequency fields, the radiating element shall be installed such that a minimum separation distance of 20cm shall be maintained from the user and/or general population.

Industry Canada

This Class B digital apparatus meets all requirements of the Canadian Interference Causing Equipment Regulations. Operation is subject to the following two conditions: (1) this device may not cause harmful interference, and (2) this device must accept any interference received, including interference that may cause undesired operation.

Cet appareillage numérique de la classe B répond à toutes les exigences de l'interférence canadienne causant des règlements d'équipement. L'opération est sujette aux deux conditions suivantes: (1) ce dispositif peut ne pas causer l'interférence nocive, et (2) ce dispositif doit accepter n'importe quelle interférence reçue, y compris l'interférence qui peut causer l'opération peu désirée.

“To reduce potential radio interference to other users, the antenna type and its gain should be so chosen that the equivalent isotropically radiated power (e.i.r.p.) is not more than that permitted for successful communication.”

“This device has been designed to operate with the antennas listed below, and having a maximum gain of 12 dB. Antennas not included in this list or having a gain greater than 12 dB are strictly prohibited for use with this device. The required antenna impedance is 50 ohms.”

RFM 12 dB Patch Antenna

RFM 9 dB Monopole Antenna

OEM Installation and Compliance Labeling

The XDM2140 module is labeled with its own FCC ID number, and, if the FCC ID is not visible when the module is installed inside another device, then the outside of the device into which the module is installed must also display a label referring to the enclosed transmitter module.

This exterior label can use wording such as the following:

“Contains Transmitter Module FCC ID: HSW-XDM2140” or

“Contains FCC ID: HSW-XDM2140”

Any similar wording that expresses the same meaning may be used. The Grantee may either provide such a label, an example of which must be included in the application for equipment authorization, or, must provide adequate instructions along with the module which explain this requirement. In the latter case, a copy of these instructions must be included in the application for equipment authorization.

The antenna connections from the module to the certain antennas approved with this device are not unique and require Professional installation.



XDM2140

Product Overview

Based on DUST Networks' SmartMesh-XD™ technology, RFM's XDM2140 module is designed to provide excellent communications reliability and long battery life in a wide range of sensor network applications. The XDM2140's combination of an IEEE802.15.4 transceiver and Time Synchronized Mesh Protocol (TSMP) blends the reliability of self-organizing and self-healing mesh networking with synchronized power duty cycling to achieve very long battery life operation. The XDM2140 is tailored for use in battery and line powered wireless devices for applications that require proven performance and scalability. The multifunctional interface of the XDM2140 gives it the flexibility to be used in a wide variety of applications, from energy management to building control to machine health monitoring. The XDM2140 requires no embedded programming, greatly reducing the development time and cost of a wireless sensor network application. The XDM2140 is certified for unlicensed operation in the USA, Canada and Europe. The XDM2140 complies with Directive 2002/95/EC (RoHS)

**2.4 GHz
Ultra Low Power
Mesh
RF Transceiver
Module**

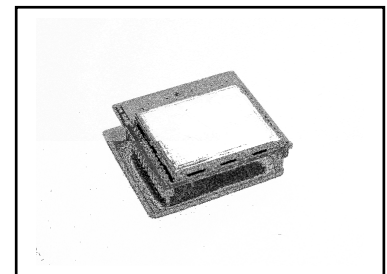

Key Features

Ultra Low Power Consumption

- Innovative radio design consumes 80% less power in receive mode than competing solutions
- Ultra-efficient power usage, enabled through SmartMesh Intelligent Network management, delivers over a decade of network operation on two AA batteries
- Automatic network-wide coordination for efficient power usage

Ultra Reliable Networking

- SmartMesh-XD™ protocol delivers greater than 99.9% typical network reliability
- Frequency hopping provides interference rejection and minimizes multipath fading
- Mesh networking provides built-in redundancy
- Every XDM2140 acts as both an endpoint and a router, increasing network reliability with mesh-to-the edge™
- Automatic self-organizing mesh networking capability built in

Easy Integration

- XDM2140 provides all the module functionality with no embedded programming or complex configuration requirements
- XDM2140 interfaces is well designed and multi-functional
- High-level Data Link Control (HDLC) serial interface includes bi-directional flow control
- Industrial temperature range -40 to +85 °C
- XDM2140P version for plug in installation, XDM2140C version for solder reflow

Applications

- Building Monitoring and Control
- Machine Health Monitoring
- Structural Integrity Monitoring
- Energy Management
- Asset Management
- Temperature Monitoring
- Urban Infrastructure Monitoring
- Agricultural/Forestry Sensor Networks

Table of Contents

1.0 XDM2140 Introduction.....	4
2.0 Absolute Maximum Ratings.....	6
3.0 Normal Operating Conditions.....	6
3.1 Current Consumption.....	6
4.0 Electrical Specifications.....	7
4.1 Device Load.....	7
4.2 Digital I/O Type 1.....	7
4.3 Digital I/O Type 2.....	7
5.0 RF Specifications.....	8
5.1 Radio Specifications.....	8
5.2 Antenna Specifications.....	8
6.0 Module Pinout.....	9
7.0 Boot Sequence.....	10
8.0 Hardware Interfaces.....	10
8.1 /RESET IN.....	10
8.2 /TIME.....	10
8.3 /LED.....	11
8.4 Settable I/O Modes.....	11
8.4.1 Mode1 - Three/Four/Five-signal Serial Interface (9600 b/s).....	11
8.4.2 Mode 3 - Five-signal Serial Interface (9600 b/s).....	12
8.4.3 UART Timing Values.....	13
9.0 Command Set.....	15
9.1 Command Data Types.....	15
9.2 Command Format.....	15
9.2.1 Command 0x80 - Serial Payload Sent to Serial Port.....	16
9.2.2 Command 0x81 - Unacknowledged Serial Payload Received from Serial Port.....	16
9.2.3 Command 0x82 - Acknowledged Serial Payload Received from Serial Port.....	17
9.2.4 Command 0x84 - Time/State Packet.....	17
9.2.5 Commands 0x87 and 0x88 - Set Parameter Request/Response.....	18
9.2.6 Commands 0x89 and 0x8A - Get Parameter Request/Response.....	18
9.2.7 Command 0x8C - XDM2140 Information.....	19
9.2.8 Command 0x8D - Reset XDM2140.....	19
9.2.9 Command 0x09 - Deep Sleep.....	19
9.3 Get/Set Command Parameters.....	20
9.3.1 Error Codes.....	21
9.3.2 Parameter Type 0x01 - Network ID.....	21
9.3.3 Parameter Type 0x02 - XDM2140 State.....	21
9.3.3.1 Configuration Change Flag (CCF).....	23
9.3.4 Parameter Type 0x03 - Frame Length.....	23
9.3.5 Parameter Type 0x04 - Join Key.....	23
9.3.6 Parameter Type 0x05 - Time/Status.....	24

9.3.7	Parameter Type 0x07 - XDM2140 Information	24
9.3.8	Parameter Type 0x08 - Power Amplifier	25
9.3.9	Parameter Type 0x0A - Charge Consumption	26
9.3.10	Parameter Type 0x0B - Power Source	27
9.4	HDLC Packet Examples	28
10.0	XDM2140 Outline Drawings	31
10.1	XDM2140P Pinned Configuration	31
10.2	XDM2140C Castellated Pad Configuration	31

1.0 XDM2140 Introduction

RFM's XDM2140 is a 2.4 GHz IEEE 802.15.4 radio module designed to provide excellent communications reliability and long battery life in a wide range of sensor network applications. The XDM2140 employs DUST Networks' SmartMesh-XD™ technology which blends the reliability of self-organizing and self-healing mesh networking with synchronized power duty cycling to achieve very long battery life operation. The XDM2140 is certified for unlicensed operation in the USA, Canada and Europe. An example XDM2140 network is shown in Figure 1. The network consists of a Gateway and up to 250 XDM2140-based Sensor Nodes. The Gateway consists of a SmartMesh-XD™ radio and a single-board Linux computer. The Gateway includes the XDM2140 network manager function and provides the application interfaces. The Gateway includes an Ethernet port that supports XML-based network commands, and two RS232 serial ports that support binary string network commands, diagnostics, etc.

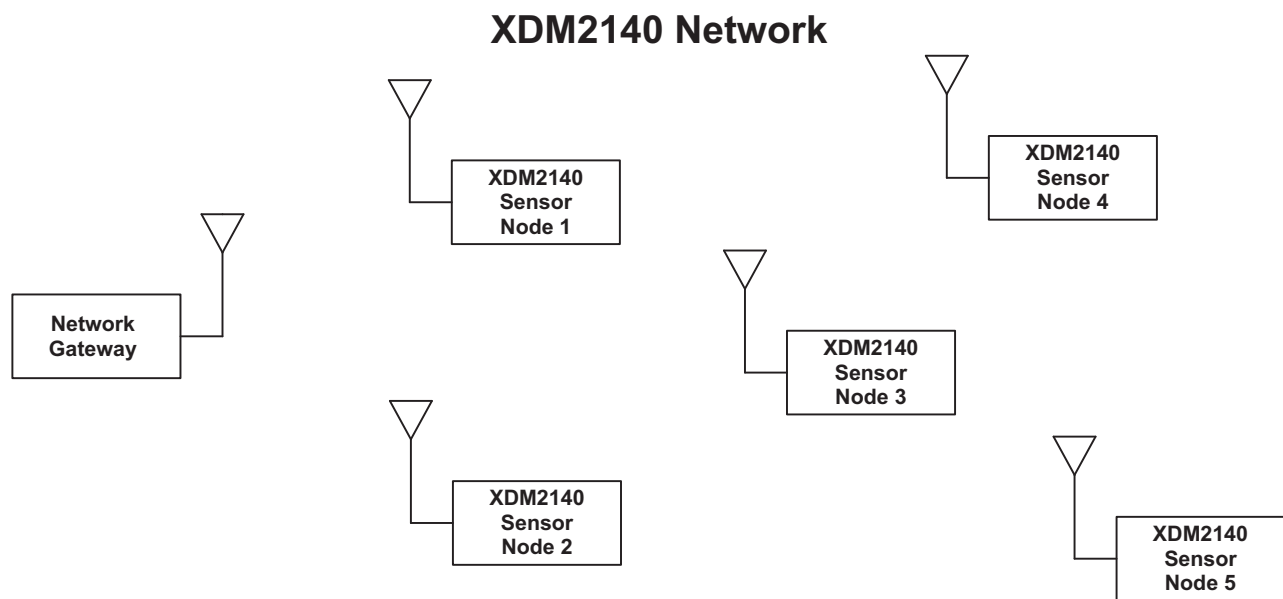

Figure 1

SmartMesh-XD™ traffic is organized in to TDMA frames consisting of 31.25 ms time slots. The Gateway assigns time slots to each XDM2140 node in the network, and then maintains a precise report interval (frame-to-frame period) to provide a highly synchronized network. Network operation also hops from channel to channel in a pseudorandom pattern to mitigate the effects of multipath fading and narrowband interference. The Gateway monitors performance on each channel and will temporarily discontinue the use of a channel that is showing poor performance statistics.

Mesh networking allows traffic to be passed from sensor node to sensor node so that messages can be delivered to and from sensor nodes that can not communicate directly with the Gateway. At least two paths are maintained by the network for communication between each field node and the Gateway. As needed, a new paths will be automatically established to replace a failing paths to maintain network performance.

As shown in Figure 2, each sensor node in the network consists of an XDM2140 radio module and a host microcontroller with sensor I/O electronics. The host microcontroller communicates with the XDM2140 radio module on a serial interface using binary command and response strings as discussed in Section 9 of this document.

Typical XDM2140 Application

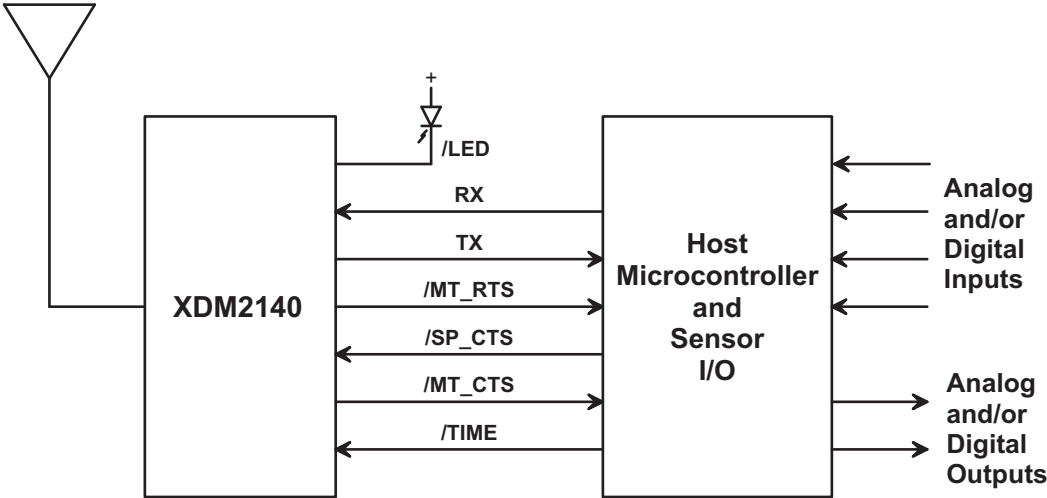

Figure 2

RFM's XDM2140 delivers the exceptional network reliability and long battery life capabilities of SmartMesh-XD™ technology in a fully functional, certified radio module that is easily interfaced to a wide variety of sensor network applications.

2.0 Absolute Maximum Ratings

The ratings below should not be exceeded under any circumstances. Damage can be caused by exceeding one or more of these parameters.

Parameter	Min	Typ	Max	Units	Comments
Supply voltage (V_{DD} to V_{SS})	-0.3		5.5	V	
Voltage on any digital I/O pin	-0.3		3.6	V	
Input RF level			10	dBm	Input power at antenna connector
Storage temperature range	-40		+85	°C	
VSWR of antenna			3:1		
ESD protection					
Antenna pad			±250	V	HBM
All other pads			±2	kV	HBM
			±200	V	CDM
* All voltages are referenced to V_{SS} .					

Caution! This is an ESD sensitive device. Use proper ESD handling procedures when working with the device to prevent permanent damage.

Table 1

3.0 Normal Operating Conditions

Parameter	Min	Typ	Max	Units	Comments
Operational supply voltage range (between V_{DD} and V_{SS})	3.3	3.6	5.5	V	Including noise and load regulation
Voltage supply noise			100	mV _{p-p}	50 Hz to 2 MHz
Operating temperature range	-40		+85	°C	
Maximum allowed ambient temperature ramp during operation			8	°C/min	-40 °C to +85 °C
Operating relative humidity	10		90	% RH	Non-condensing

Unless otherwise noted, V_{DD} is 3.6 V and temperature is -40 °C to +85 °C.

Table 2

3.1 Current Consumption

Parameter	Min	Typ	Max	Units	Comments
Transmit		18		mA	
Receive		6		mA	
Sleep		8.5		μA	

Table 3

4.0 Electrical Specifications

4.1 Device Load

Parameter	Min	Typ	Max	Units	Comments
Total capacitance			0.5	μF	
Total inductance			84	nH	

Unless otherwise noted, V_{DD} is 3.6 V and temperature is $-40\text{ }^{\circ}\text{C}$ to $+85\text{ }^{\circ}\text{C}$.

Table 4

4.2 Digital I/O Type 1

Digital Signal	Min	Typ	Max	Units	Comments
V_{IL} (low-level input voltage)	-0.3		0.6	V	
V_{IH} (high-level input voltage)	$0.8 \times V_{\text{DD}}$		$V_{\text{DD}} + 0.3$	V	
V_{OL} (low-level output voltage)			0.4	V	
V_{OH} (high-level output voltage)	2.4			V	
Digital current [*]					
Output source (single pin)		3.7		mA	25 $^{\circ}\text{C}$
Output sink (single pin)		2.0		mA	25 $^{\circ}\text{C}$
Input leakage current		50		nA	

^{*} This current level guarantees that the output voltage meets V_{OH} and V_{OL} specifications above.

Table 5

4.3 Digital I/O Type 2

Digital Signal	Min	Typ	Max	Units	Comments
V_{IL} (low-level input voltage)	-0.3		0.6	V	
V_{IH} (high-level input voltage)	$0.8 \times V_{\text{DD}}$		$V_{\text{DD}} + 0.3$	V	
V_{OL} (low-level output voltage, multi-function I/O configured as output)	0		0.6	V	$I_{\text{OL}} < 0.6\text{ mA}$, 85 $^{\circ}\text{C}$
V_{OH} low-level output voltage, multi-function I/O configured as output)	$V_{\text{DD}} - 0.6$		V_{DD}	V	$I_{\text{OH}} > -0.4\text{ mA}$, 85 $^{\circ}\text{C}$
Digital current [*]					
Output source (single pin, multifunction I/O configured as output)		0.4		mA	25 $^{\circ}\text{C}$
Output sink (single pin, multifunction I/O configured as output)		0.6		mA	25 $^{\circ}\text{C}$
Input leakage current		50		nA	

^{*} This current level guarantees that the output voltage meets V_{OH} and V_{OL} specifications above.

Table 6

5.0 RF Specifications

5.1 Radio Specifications

Parameter	Min	Typ	Max	Units	Comments
Operating frequency	2.4000		2.4835	GHz	
Number of channels		15			
Channel separation		5		MHz	
Occupied channel bandwidth		2.7		MHz	at -20 dBc
Frequency accuracy	-50		+50	kHz	
Modulation					IEEE 802.15.4 DSSS
Raw data rate		250		kb/s	
Receiver operating maximum input level		0		dBm	
Receiver sensitivity		-92.5		dBm	At 50% PER, $V_{DD} = 3\text{ V}$, 25 °C
		-90		dBm	At 1% PER, $V_{DD} = 3\text{ V}$, 25 °C, (inferred from 50% PER measurement)
Output power, conducted		+8		dBm	$V_{DD} = 3\text{ V}$, 25 °C

Table 7

5.2 Antenna Specifications

The antenna must meet specifications below. When the XDM2140 is placed inside an enclosure, the antenna should be mounted such that the radiating portion of the antenna protrudes from the enclosure, and connected using a coaxial cable. For optimum performance, allow the antenna to be positioned vertically when installed. The XDM2140 has been FCC certified as a module with both a dipole antenna and a patch antenna. Any 2.4 GHz dipole antenna or 2.4 GHz patch antenna with a gain less than or equal to 12 dBi may be used without the need for any FCC type acceptance testing. If a different antenna type or a higher gain dipole or patch is to be used, please contact RFM Technical Support for more information.

Antenna Parameter	Value
Frequency range	2.4000 - 2.4835 GHz
Impedance	50 ohms
Maximum VSWR	3:1

Table 8

6.0 Module Pinout

Pin Number	Pin Name	Description
1	GND	Connect to the host circuit board ground.
2	NC	Leave unconnected.
3	NC	Leave unconnected.
4	NC	Leave unconnected.
5	UART_TX	Serial data output from UART.
6	UART_RX	Serial data input from UART.
7	/MT_RTS	Active low output to the host signaling the XDM2140 has a packet to deliver.
8	MODE	Mode B input, normally grounded.
9	NC	Leave unconnected.
10	/SP_CTS	Active low input from the host signaling it is ready to receive a packet.
11	/TIME	Active low input to trigger the XDM2140 to send a timestamp packet.
12	/MT_CTS	Active low clear to send output from XDM2140 to the host.
13	NC	Leave unconnected.
14	VBAT	Power supply input, +3.3 to +5.5 Vdc
15	GND	Connect to the host circuit board ground.
16	GND	Connect to the host circuit board ground.
17	/RESET IN	Active low XDM2140 reset input.
18	/LED	Active low status LED driver output.
19	NC	Leave unconnected.
20	NC	Leave unconnected.
21	NC	Leave unconnected.
22	NC	Leave unconnected.
23	NC	Leave unconnected.
24	NC	Leave unconnected.
25	NC	Leave unconnected.
26	NC	Leave unconnected.
27	NC	Leave unconnected.
28	GND	Connect to the host circuit board ground.
29	NC	Leave unconnected.
30	GND	Connect to the host circuit board ground.
RF	Connector	U.FL coaxial antenna connector.

Table 9

7.0 Boot Sequence

Following the active low assertion of /RESET IN, the XDM2140 completes its boot-up process by loading and decrypting the application image and loading the operating parameters. During the boot process, the modules output signals are not actively driven and the input signals are ignored. The duration of the boot process is defined in Table 10.

Boot Parameter	Min	Typ	Max	Units	Comments
t_{boot_delay}			6	s	The time between power up and serial interface availability

Table 10

8.0 Hardware Interfaces

8.1 /RESET IN

When this signal is asserted low, the XDM2140 is hardware reset until the signal is de-asserted. Note that the XDM2140 may also be reset using the mote serial command. If a system is designed to assert /RESET IN after the XDM2140 has completed its boot process, it is recommended the module be placed into deep sleep prior to assertion of the /RESET IN signal.

8.2 /TIME

The XDM2140 has the ability to deliver network-wide synchronized timestamps. The XDM2140 sends a time packet through its serial interface when one of the following occurs:

- HDLC Get Parameter request for time/state is received.
- Active-low /TIME signal is asserted.

Use of the /TIME input is optional but has the advantage of being more accurate. The value of the timestamp is taken within approximately 1 ms of receiving a /TIME signal assertion. The XDM2140 will send the time packet of the local host microcontroller within 100 ms of the strobe. If the HDLC request is used, due to packet processing the value of the timestamp may be captured several milliseconds after receipt of the packet. The real time delivered to the sensor processor is relative to the real-time clock on the Gateway, which serves as the Network Real Time Clock (NRTC). The time stamp skew across the network is guaranteed to be within ± 250 ms of the NRTC.

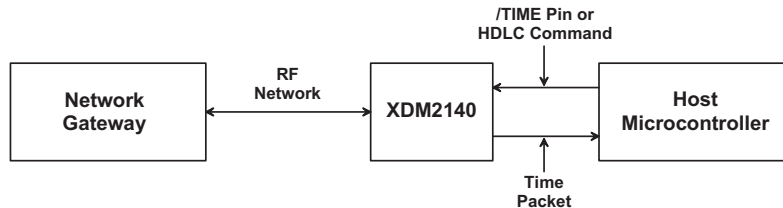

Figure 3

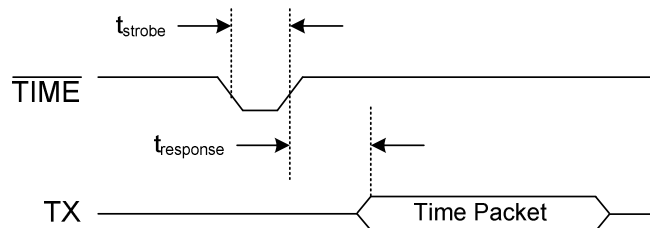

Figure 4

/TIME Parameters	Meaning	Min	Max	Units
t _{strobe}	TIME strobe pulse width	125		μs
t _{response}	TIME strobe active low assertion to start of time packet		100	ms

Table 11

8.3 /LED

The XDM2140 provides an output to drive a status LED. This signal indicates network connectivity information, which is useful during XDM2140 system installation. Alternatively, the XDM2140 status may be polled using the serial Get Parameter request with the module state parameter.

/LED Signal Behavior	Mote State
High	Off, or in sleep mode
Single blink (750 ms low, 3 s high)	On, and searching for potential network
Double blink (750 ms low, 750 ms high, 750 ms low, 3 s high)	On, and attempting to join the network
Triple blink (750 ms low, 750 ms high, 750 ms low, 750 ms high, 750 ms low, 3 s high)	On, and attempting to establish redundant links
Low	On, fully configured into network with redundant parents

Table 12

8.4 Settable I/O Modes

The XDM2140 offers a choice of two I/O modes. The functionality of the interface will be determined by the setting MODE input.

MODE Pin Setting	Mode 1	Mode 3
Setting	Externally tied low	Externally tied high

Table 13

Both modes provide a means of transmitting and receiving serial data through the wireless network, and a command interface that provides synchronized time stamping, local configuration and diagnostics. Mode 1 implements an 8-bit, no parity, 9600 baud, three, four or five-signal serial interface with bidirectional packet-level flow control operating at 9600 b/s. In certain designs, one or two of the serial handshake signals may be optional for reduced pin count. Please refer to detailed descriptions of signals. Mode 3 implements an 8-bit, no parity, 9,600 baud, five-signal serial interface with bidirectional packet-level flow control and byte-level flow control in the XDM2140-to-microcontroller direction only.

8.4.1 Mode 1 - Three/Four/Five-signal Serial Interface (9600 b/s)

XDM2140 Mode 1 provides a three, four, or five-signal serial interface optimized for low-powered embedded applications, and in certain designs may provide a lower pin count serial solution. The Mode 1 serial interface comprises the data pins UART_TX and UART_RX, with handshake pins /MT_RTS, /MT_CTS, /SP_CTS used for bidirectional flow control. The /MT_RTS signal is ideal for designs where the host microcontroller requires extra time to prepare to receive a packet. For example, when the host microcontroller sleeps periodically and requires a wake-up signal prior to receiving a packet. Refer to Table 14 for information on each pin, including details on which pins are optional.

Mode 1 Pin Usage

Pin	I/O	Usage
RX	Input	Serial data moving from the microcontroller to the XDM2140.
TX	Output	Serial data moving from the XDM2140 to the microcontroller.
/MT_RTS	Output	/MT_RTS provides a mechanism to wake up the microcontroller in order to receive a packet. This signal is asserted when the XDM2140 is ready to send a serial packet. The signal stays low until the /SP_CTS signal from the microcontroller is detected low by the XDM2140 (indicating readiness to receive a packet) or the timeout defined in Section 8.4.3 expires. /MT_RTS may be ignored by the microcontroller only if /SP_CTS always stays low.
/SP_CTS	Input	/SP_CTS provides <i>packet level</i> flow control for packets transferred from the XDM2140 to the microcontroller. When the microcontroller is capable of receiving a packet it should assert the /SP_CTS signal. /SP_CTS may be externally tied low (reducing pin count) only if the microcontroller is always ready to receive a serial packet.
/MT_CTS	Output	/MT_CTS provides packet level flow control for packets transferred from the microcontroller to the XDM2140 that are destined for transfer over the network. Upon reset, following boot the XDM2140 will negate /MT_CTS until the XDM2140 establishes a wireless network connection. During operation, the XDM2140 will negate /MT_CTS if the XDM2140 does not have sufficient buffering to accept another packet. /MT_CTS will also remain high if the XDM2140 is not part of the network. The microcontroller must check that the /MT_CTS pin is low before initiating each serial packet for wireless transmission. Note that the XDM2140 may receive local serial packets at any time regardless of the /MT_CTS state.
/TIME	Input	The /TIME pin can be used for triggering a timestamp packet. Its usage is optional.

Table 14

8.4.2 Mode 3 - Five-signal Serial Interface (9600 b/s)

XDM2140 Mode 3 provides a five-signal serial interface with *byte-level flow control* on transfers from the XDM2140 to the microcontroller. The Mode 3 serial interface is comprised of the data pins UART_TX and UART_RX, with handshake pins /MT_RTS, /MT_CTS and /SP_CTS used for bidirectional flow control. The /MT_RTS signal is ideal for designs where the microcontroller requires extra time to prepare to receive a packet. For example, the host microcontroller sleeps periodically and requires a wake-up signal prior to receiving a packet). Refer to Table 15 for information on each handshake pin, including details on which of those pins are optional.

Mode 3 Pin Usage

Pin	I/O	Usage
RX	Input	Serial data moving from the microcontroller to the XDM2140.
TX	Output	Serial data moving from the XDM2140 to the microcontroller.
/MT_RTS	Output	/MT_RTS provides a mechanism to wake up the microcontroller in order to receive a packet. This signal is asserted when the XDM2140 is ready to send a serial packet. The signal stays low until the /SP_CTS signal from the microcontroller is detected low by the XDM2140 (indicating readiness to receive a packet) or the t_{ack_delay} timeout defined in Section 8.4.3 expires.
/SP_CTS	Input	/SP_CTS provides both <i>packet</i> and <i>byte level</i> flow control for packets transferred from the XDM2140 to the microcontroller. When the microcontroller is capable of receiving a packet it should assert the /SP_CTS signal. In Mode 3, byte-level flow control is achieved by having the microcontroller negate and then reassert the /SP_CTS signal following the receipt of each byte. The XDM2140 will begin transmission of the next byte after detecting the reassertion of /SP_CTS.
/MT_CTS	Output	/MT_CTS provides packet level flow control for packets transferred from the microcontroller to the XDM2140 that are destined for transfer over the network. Upon reset, following boot the XDM2140 will negate /MT_CTS until the XDM2140 establishes a wireless network connection. During operation, the XDM2140 will negate /MT_CTS if the XDM2140 does not have sufficient buffering to accept another packet. /MT_CTS will also remain high if the XDM2140 is not part of the network. The microcontroller must check that the /MT_CTS pin is low before initiating each serial packet for wireless transmission. Note that the XDM2140 may receive local serial packets at any time regardless of the /MT_CTS state.
/TIME	Input	The /TIME pin can be used for triggering a timestamp packet. Its usage is optional.

Table 15

8.4.3 UART Timing Values

Variable	Meaning	Min	Max	Units
t_{RX_BAUD}	Deviation from baud rate	-2	+2	%
t_{RX_STOP}	Number of stop bits	1		bit period
t_{TX_BAUD}	Deviation from baud rate	-1	+1	%
t_{TX_STOP}	Number of stop bits	1		bit period
$t_{SP_CTS\ to\ MT_RTS}$	Assertion of /SP_CTS to negation of /MT_RTS	0	10	ms
$t_{MT_RTS\ to\ SP_CTS}$	Assertion of /MT_RTS to assertion of /SP_CTS		500	ms
$t_{SP_CTS\ to\ TX}$	Assertion of /SP_CTS to start of byte	0	10	ms
$t_{TX\ to\ SP_CTS}$	Start of byte to negation of /SP_CTS	1		bit period
$t_{SP_CTS\ ack\ PW}$	Negation pulse width of /SP_CTS	500		ns
$t_{diag_ack_timeout}$	The XDM2140 responds to all requests within this time.		125	ms
$t_{min_strobe_length}$	The minimum length of the strobe signals, /TIME and /SP_CTS	500		ns
$t_{interbyte_timeout}$	Falling edge of TX to falling edge of /SP_CTS (Mode 3 only)		8	ms
$t_{interpacket_delay}$	The sender of an HDLC packet must wait at least this amount of time before sending another packet	20		ms
t_{ack_delay}	The max time delay between the /MT-RTS and the receiver's acknowledge, /SP_CTS	1	500	ms
$t_{time_ack_timeout}$	The XDM2140 responds to all /TIME pin activation requests within this time		100	ms

Table 16

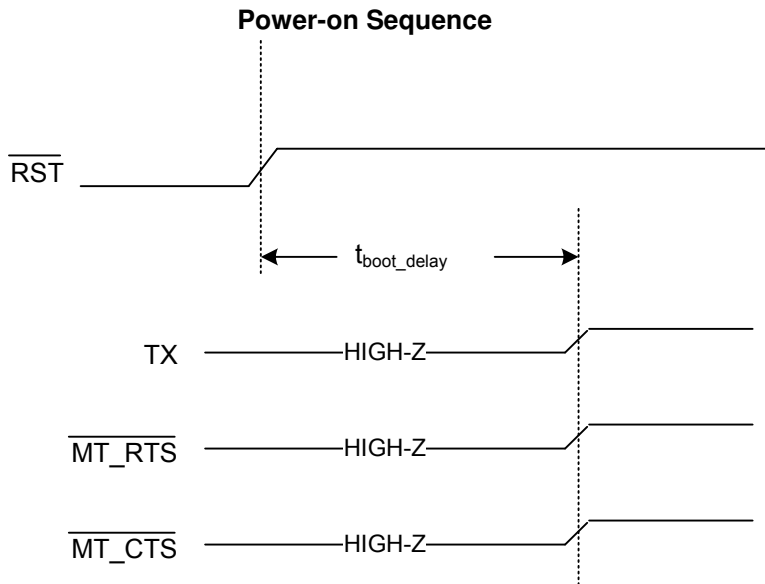

Figure 5

Byte-level Timing

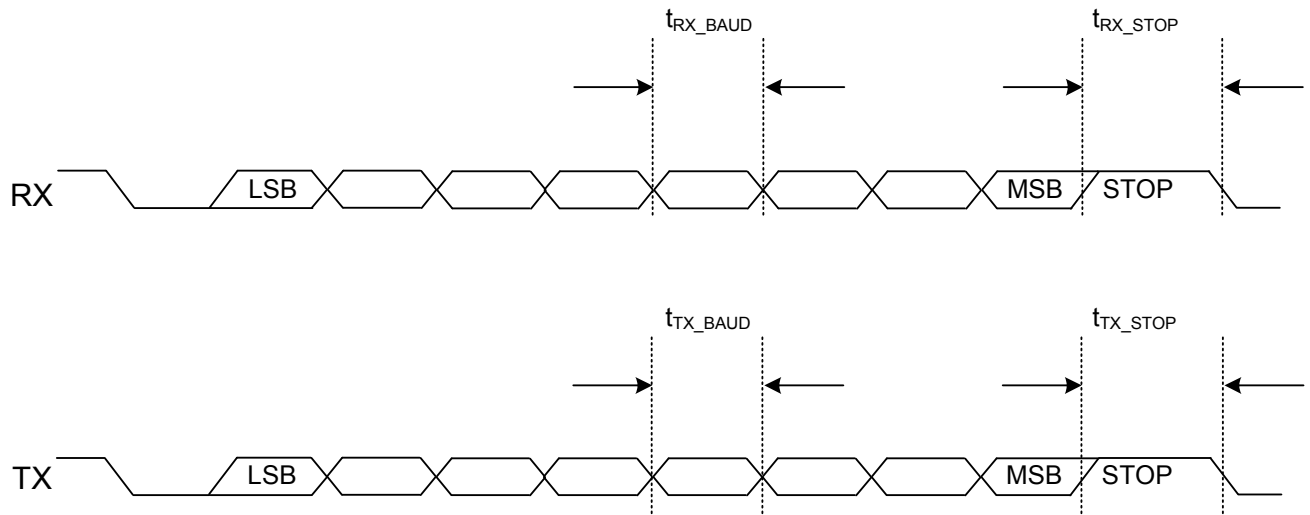

Figure 6

Flow Control Timing

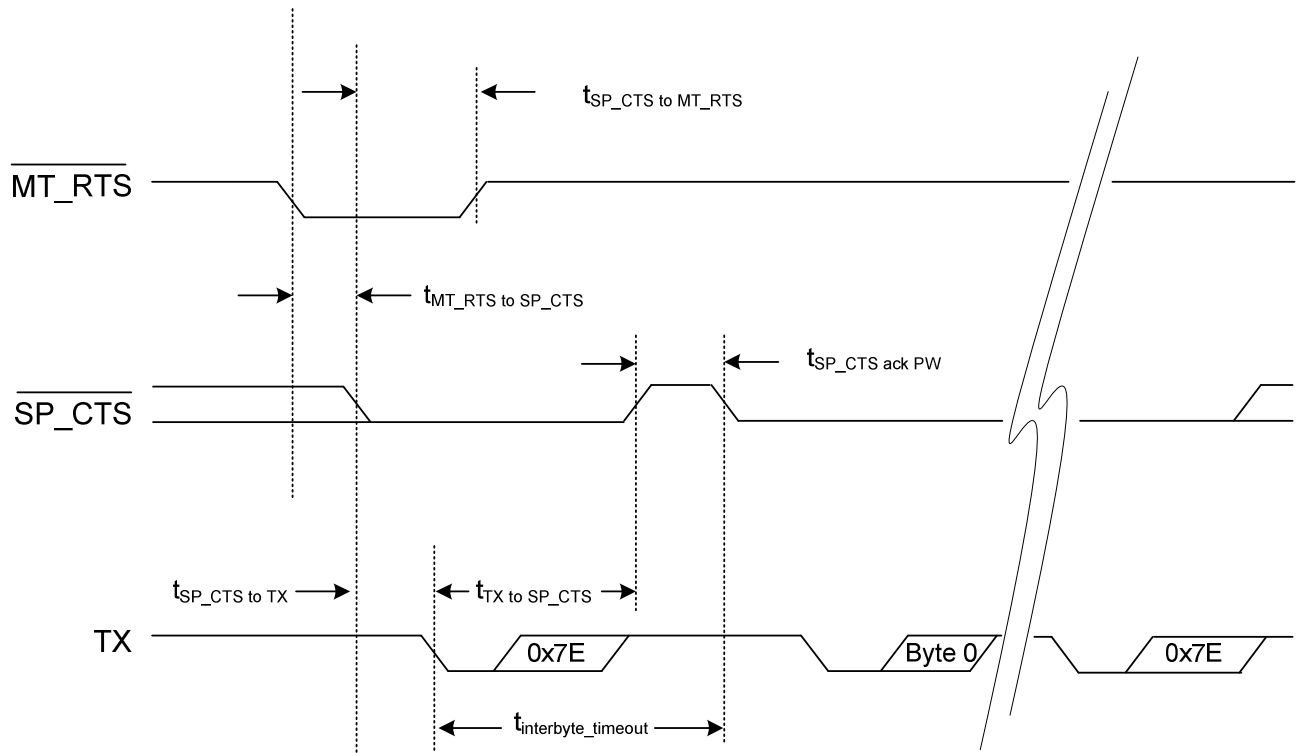

Figure 7

Packet Timing

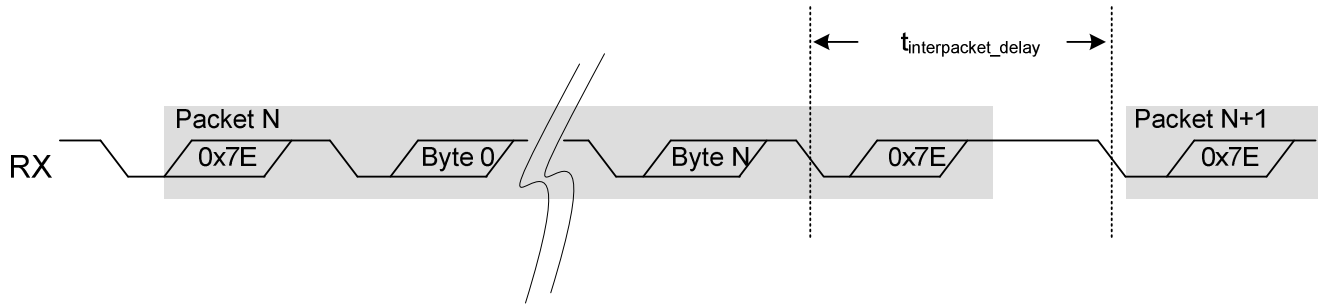

Figure 8

9.0 Command Set

9.1 Command Data Types

Table 17 below defines the data types used in the commands:

Command Data Types	Length
unsigned long	4 bytes
unsigned short	2 bytes
unsigned char	1 bytes

Table 17

9.2 Command Format

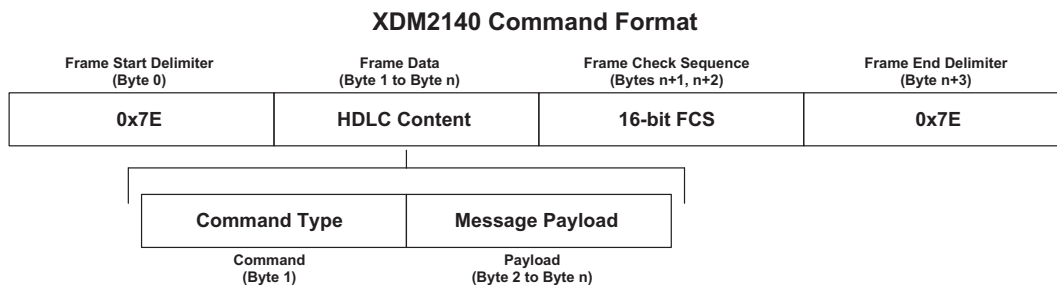

Figure 9

HDLC Packet Structure

The command type indicates which API message is contained in the message payload. The message payload for each command type is described within the following sections. The length of the message payload is 80 bytes (excluding byte-stuffing bytes).

The frame checksum (FCS) is calculated based on the 16-bit FCS computation method (FCS-16, RFC 1662). The XDM2140 checks the FCS and drops packets that have FCS errors. All numerical fields in a packet are in big-endian order (MSB first), unless otherwise noted. Section 9.4 provides an example of HDLC packet construction and HDLC packet decoding.

Table 18 provides a summary of XDM2140 commands, which are described in detail in the following sections. For error handling, all other packet types should be ignored. The Destination column indicates whether the packet is sent (or received) through the network or processed locally by the XDM2140.

XDM2140 Command Summary

Command Type (HEX)	Direction	Destination	Description
0x80	Microcontroller to XDM2140	Network	Packet destined for the network
0x81	XDM2140 to microcontroller	Network	Unacknowledged packet received from the network and destined for microcontroller
0x82	XDM2140 to microcontroller	Network	Acknowledged packet received from the network and destined for microcontroller
0x83	—	—	Reserved
0x84	XDM2140 to microcontroller	Local	Time and XDM2140 state information
0x85	—	—	Reserved
0x86	—	—	Reserved
0x87	Microcontroller to XDM2140	Local	Set Parameter request
0x88	XDM2140 to microcontroller	Local	Set Parameter response
0x89	Microcontroller to XDM2140	Local	Get Parameter request
0x8A	XDM2140 to microcontroller	Local	Get Parameter response
0x8C	XDM2140 to microcontroller	Local	XDM2140 information
0x8D	Microcontroller to XDM2140	Local	Reset XDM2140
0x09	Microcontroller to XDM2140	Local	Deep sleep
0x0B	Microcontroller to XDM2140	Local	Test radio transmission
0x0C	Microcontroller to XDM2140	Local	Test radio reception
0x02	Microcontroller to XDM2140	Local	Get radio reception test statistics

Table 18

9.2.1 Command 0x80 - Serial Payload Sent to Serial Port

Serial Data Packets going into the XDM2140 serial port use the command type 0x80. Upon receiving the packet, the XDM2140 forwards it to the network. The format of the serial packet payload is transparent to the XDM2140. There is no response by the XDM2140 upon reception of this command.

Command 0x80 Format Details

Message Byte	Description	Data Type	Request (Sent to XDM2140)
1	Command type	unsigned char	0x80
2		(Transparent to XDM2140)	First byte of data
...2+n		(Transparent to XDM2140)	Up to n-1 additional bytes of data

Table 19

9.2.2 Command 0x81 - Unacknowledged Serial Payload Received from Serial Port

Unacknowledged serial data packets going out of the XDM2140 serial port use command type 0x81. The network uses this command to send data out through the XDM2140 serial interface. Upon receiving this packet from the network, the XDM2140 forwards it to the microcontroller without sending acknowledgement to the Gateway. The format of the serial packet payload is transparent to the XDM2140. The maximum length of the message payload is defined in Section 9.2.

Command 0x81 Format Details

Message Byte	Description	Data Type	Value
1	Command type	unsigned char	0x81
2		(Transparent to XDM2140)	First byte of data
...2+n		(Transparent to XDM2140)	Up to n-1 additional bytes of data

Table 19

9.2.3 Command 0x82 - Acknowledged Serial Payload Received from Serial Port

Acknowledged serial data packets going out of the XDM2140 use command type 0x82. The network uses this command to send data out through the XDM2140 serial interface. Upon receiving this packet from the network, the XDM2140 forwards it to the microcontroller and sends an acknowledgement back to the Gateway. The format of the serial packet payload is transparent to the XDM2140. The maximum length of the message payload is defined in Section 9.2. The microcontroller receives exactly one copy of the message that was sent through the network.

Command 0x82 Format Details

Message Byte	Description	Data Type	Value
1	Command type	unsigned char	0x82
2		(Transparent to XDM2140)	First byte of data
...2+n		(Transparent to XDM2140)	Up to n-1 additional bytes of data

Table 20

9.2.4 Command 0x84 - Time/State Packet

Time data packets use the command type 0x84. The time packet includes the network time and the current real time relative to the Gateway. The XDM2140 sends this response when the /TIME pin is strobed high to low for minimum of $t_{\text{min_strobe_length}}$, as defined in Section 8.4.3. The data returned is identical to that returned in response to the Get parameter request with time as the parameter.

Command 0x84 Format Details

Message Byte	Description	Data Type	Value
1	Command type	unsigned char	0x84
2-5	The sequential number of the frame	unsigned long	Cycle
6-9	The offset from start of frame	unsigned long	Offset (μs)
10-11	Frame length	unsigned short	Frame length (slots)
12-15	UTC time	unsigned long	Real time part 1 (s)
16-19	UTC time	unsigned long	Real time part 2 (μs)
20-23	Time from the last XDM2140 reset	unsigned long	XDM2140 uptime (s)
24	XDM2140 state	unsigned char	XDM2140 state
25	XDM2140 diagnostics status	unsigned char	XDM2140 diagnostics status

Table 21

9.2.5 Commands 0x87 and 0x88 - Set Parameter Request/Response

The Set Parameter command allows the setting of a number of configuration parameters in the XDM2140. When the Set Parameter Request command is sent, the response to the request is sent within the `diag_ack_timeout`. The command structure for individual Parameter Types and can be found in Section 9.3. The length of payload (n) is dependant on the Parameter type.

Command 0x87 Format Details

Message Byte	Description	Data Type	Value
1	Command type	unsigned char	0x87
2	Parameter type	unsigned char	Parameter type (see Section 9.3)
3	Data		First byte of data
...3+n	Data		Up to n-1 additional bytes of data

Table 22

Response 0x88 Format Details

Message Byte	Description	Data Type	Value
1	Command type	unsigned char	0x88
2	Parameter type	unsigned char	Parameter type (see Section 9.3)
3	Error code	unsigned char	Error code
4	Data length	unsigned char	0x00

Table 23

9.2.6 Commands 0x89 and 0x8A - Get Parameter Request/Response

The Get Parameter command allows a number of configuration parameters in the XDM2140 to be read by the serial port. When a Get Parameter Request command is sent, the response to the request is sent within the `diag_ack_timeout`. The command structure for individual parameter types can be found in Section 9.3. The length of payload (n) depends on the parameter type. If the error code is not equal to zero, no data is returned in the response. Error codes are described in Table 38.

Command 0x89 Format Details

Message Byte	Description	Data Type	Value
1	Command type	unsigned char	0x89
2	Parameter type	unsigned char	Parameter type (see Section 9.3)
3	Data		First byte of data
...3+n	Data		Up to n-1 additional bytes of data

Table 24

Response 0x8A Format Details

Message Byte	Description	Data Type	Value
1	Command type	unsigned char	0x8A
2	Parameter type	unsigned char	Parameter type (see Section 9.3)
3	Error code	unsigned char	Error code (see Table 38)
4	Data length	unsigned char	n
5	Data		First byte of data
...5+n	Data		Up to n-1 additional bytes of data

Table 25

9.2.7 Command 0x8C - XDM2140 Information

The XDM2140 sends this packet after boot_delay following a power-up reset to supply information about the XDM2140 properties.

Command 0x8C Format Details

Message Byte	Description	Data Type	Value
1	Command type	unsigned char	0x8C
2-4	HW model	Array of 3 unsigned char	Byte 1 = 0x41 Byte 2 = 0x05 to 0x0F Byte 3 = 0x01
5-6	HW revision	Array of 2 unsigned char	HW revision
7-10	SW revision	Array of 4 unsigned char	SW revision
11-18	MAC address	Array of 8 unsigned char	MAC addr
19	Networking type	unsigned char	0x04
20-21	Network ID	unsigned short	Network ID
22-29	Datasheet ID	Array of 8 unsigned char	000_0002
30-31	XDM2140 ID	unsigned short	XDM2140 ID
32			Reserved
33	XDM2140 diagnostics status	unsigned char	XDM2140 diagnostics status

Table 26

9.2.8 Command 0x8D - Reset XDM2140

Upon receiving this command, the XDM2140 notifies its neighbors about an upcoming reset, and then proceeds to reset itself. The delay to the actual reset depends on the network configuration.

Command 0x8D Format Details

Message Byte	Description	Data Type	Value
1	Command type	unsigned char	0x8D

Table 27

9.2.9 Command 0x09 - Deep Sleep

The Deep Sleep command will put the XDM2140 into a non-functional, lowest-power consumption state with current draw on the order of a few microamps. Deep sleep is ideal when the XDM2140 is connected to its power source, but must be stored for extended periods. The XDM2140 will enter deep sleep within 2 seconds after receiving the Deep Sleep command. The XDM2140 will wake from deep sleep when either the /RESET IN pin is asserted and then de-asserted, or the XDM2140 is power cycled.

Command 0x09 Format Details

Message Byte	Description	Data Type	Value
1	Command type	unsigned char	0x09
2	Payload length	unsigned char	0x00
3	Flags	unsigned char	0x00 (request packet)

Table 28

Response 0x09 Format Details

Message Byte	Description	Data Type	Value
1	Command type	unsigned char	0x09
2	Payload length	unsigned char	0x00
3	Flags	unsigned char	0x01 (response packet)
4	Response code	unsigned char	0x00 (OK)

Table 29

9.3 Get/Set Command Parameters

This section specifies the parameters that may be used with the Get and Set Commands. Table 35 provides an overview of these parameters.

Get/Set Command Parameters

Parameter Type	Set Parameter	Get Parameter	Description
0x01	X		Set the XDM2140's network ID
0x02		X	Get the XDM2140's current network connection state
0x03		X	Get the network frame length
0x04	X		Set the network join key on the XDM2140
0x05		X	Get the network time and XDM2140 state information
0x06			Reserved
0x07		X	Get the XDM2140's properties
0x08	X	X	Set/get the power amplifier mode
0x09			Reserved
0x0A		X	Get the XDM2140's charge consumption
0x0B	X	X	Set/get the XDM2140 power source value
0x0C	X	X	Put XDM2140 into RF testing mode

Table 30

All requests have the following structure.

Request Structure for Parameter Data Packets

Command Type	Parameter Type	Data (Optional)
1 byte	1 byte	Up to 33 bytes

Table 31

All replies have the following structure.

Reply Structure for Parameter Data Packets

Command Type	Parameter Type	Error Code	Data Length	Data (Optional)
1 byte	1 byte	1 byte	1 byte	Up to 31 bytes

Table 32

Command Types, Parameter types, and error codes are discussed in the following sections. Data length is the number of bytes of following data, set to 0 in case of non-zero error code.

9.3.1 Error Codes

Error Codes are listed in Table 38 below.

Error Code Details

Number	Error	Description
0	DIAG_NO_ERR	No command-specific errors
1	DIAG_EXE_ERR	XDM2140 unable to execute command
2	DIAG_PARAM_ERR	Illegal parameter in the request

Table 33

9.3.2 Parameter Type 0x01 - Network ID

The network ID is the identification number used to distinguish different wireless networks. In order to join a specific network, the XDM2140 must have the same network ID as the network Gateway. This parameter is only valid for the Set Parameter command. Upon receiving this request, the XDM2140 stores the new network ID in its persistent storage area, but continues to use the existing network ID. The XDM2140 must be reset in order to begin using the new network ID.

Parameter Type 0x01 Set Request Details

Message Byte	Description	Data Type	Value
1	Command type	unsigned char	0x87
2	Parameter type	unsigned char	0x01
3-4	Network ID	unsigned char	Network ID

Table 34

The following packet is sent in response to a request to set the network ID.

Parameter Type 0x01 Set Response Details

Message Byte	Description	Data Type	Value
1	Command type	unsigned char	0x88
2	Parameter type	unsigned char	0x01
3	Error code	unsigned char	Error code
4	Data length	unsigned char	0x00

Table 35

9.3.3 Parameter Type 0x02 - XDM2140 State

This parameter is only valid for the Get Parameter command and is used to retrieve the XDM2140's current network connection state.

Parameter Type 0x02 Get Request Details

Message Byte	Description	Data Type	Value
1	Command type	unsigned char	0x89
2	Parameter type	unsigned char	0x02

Table 36

The following packet is sent in response to a request to retrieve the XDM2140's current network connection state.

Parameter Type 0x02 Get Response Details

Message Byte	Description	Data Type	Value
1	Command type	unsigned char	0x8A
2	Parameter type	unsigned char	0x02
3	Error code	unsigned char	Error code
4	Data length	unsigned char	0x02
5	XDM2140 state	unsigned char	XDM2140 state
6	XDM2140 diagnostics status	unsigned char	XDM2140 diagnostics status

Table 37

XDM2140 States

State Number	Description	Details
1	ACTIVE	The XDM2140 has joined the network and is waiting to be configured.
2	JOINING	The XDM2140 has sent a join request and is waiting to be activated.
3	ACT SEARCH	The XDM2140 is actively searching for neighbors.
4-5	PASS SEARCH	The XDM2140 is passively searching for neighbors.
6	SYNCHRONIZED	The XDM2140 is synchronized to a network, listening in active search.
7-8	RESETTING	The XDM2140 is going through the reset process.
9	ONLINE1	The XDM2140 has joined a network and is fully configured, but has only one parent. The XDM2140 is ready to transmit data to the network.
10	ONLINE2	The XDM2140 has joined a network, is fully configured, and has multiple parents. The XDM2140 is ready to transmit data to the network.

Table 38

Diagnostics Status

Bit	Description	Details
7	—	Reserved
6	—	Reserved
5	—	Reserved
4	—	Reserved
3	—	Reserved
2	—	Reserved
1	CCF	Configuration change flag (see Section 9.3.3.1)
0	NV_ERR	Non-volatile memory error

Table 39

9.3.3.1 Configuration Change Flag (CCF)

The Configuration Change Flag (CCF) bit is set high when the network ID is changed. Note that when the network ID is changed over the air (using the XML-API), the entire network synchronously changes over to the new network ID. There is no delay between when the XML-API command is received and when XDM2140 changes over to the new network ID. The CCF bit is set high when the new network ID becomes active. The CCF bit is cleared when the XDM2140 receives a XDM2140 Information Get request (Command 0x07), a getParameter Time command, a getParameter XDM2140 State command, or the XDM2140 is reset.

9.3.4 Parameter Type 0x03 - Frame Length

This parameter is only valid for the Get Parameter command and is used to retrieve the frame length of the specified frame ID.

Parameter Type 0x03 Get Request Details

Message Byte	Description	Data Type	Value
1	Command type	unsigned char	0x89
2	Parameter type	unsigned char	0x03
3	Frame ID	unsigned char	Frame ID

Table 40

The following packet is sent in response to a request to retrieve the frame length.

Parameter Type 0x03 Get Response Details

Message Byte	Description	Data Type	Value
1	Command type	unsigned char	0x8A
2	Parameter type	unsigned char	0x03
3	Error code	unsigned char	Error code
4	Data length	unsigned char	0x05
5	Frame ID	unsigned char	Frame ID
6-9	Frame length	unsigned long	Frame length (μ s)

Table 41

9.3.5 Parameter Type 0x04 - Join Key

The join key is needed to allow a XDM2140 on the network. The join key is specific for the network and used for data encryption. This parameter is only valid for a Set Parameter command. Upon receiving this request, the XDM2140 stores the new join key in its persistent storage. The XDM2140 must be reset in order to begin using the new join key.

Parameter Type 0x04 Set Request Details

Message Byte	Description	Data Type	Value
1	Command type	unsigned char	0x87
2	Parameter type	unsigned char	0x04
3-18	New join key	Array of 16 unsigned char	New join key

Table 42

The following packet is sent in response to a request to set the join key.

Parameter Type 0x04 Set Response Details

Message Byte	Description	Data Type	Value
1	Command type	unsigned char	0x88
2	Parameter type	unsigned char	0x04
3	Error code	unsigned char	Error code
4	Data length	unsigned char	0x00

Table 43

9.3.6 Parameter Type 0x05 - Time/State

This parameter is only valid for the Get Parameter command and is used to request the network time and XDM2140 state information. The response to this command returns the same information as Command 0x84 (Time/State Packet), with the only difference being that this command can be solicited using the Get command, rather than a hardware pin.

Parameter Type 0x05 Get Request Details

Message Byte	Description	Data Type	Value
1	Command type	unsigned char	0x89
2	Parameter type	unsigned char	0x05

Table 44

The following packet is sent in response to a request for the network time and XDM2140 state information.

Parameter Type 0x05 Get Response Details

Message Byte	Description	Data Type	Value
1	Command type	unsigned char	0x8A
2	Parameter type	unsigned char	0x05
3	Error code	unsigned char	Error code (see 0)
4	Data length	unsigned char	0x18
5-8	The sequential number of frame	unsigned long	Cycle
9-12	The offset from start of frame	unsigned long	Offset (μ s)
13-14	Frame length	unsigned short	Frame length (slots)
15-18	UTC time	unsigned long	Real time part 1 (s)
19-22	UTC time	unsigned long	Real time part 2 (μ s)
23-26	Time from the last XDM2140 reset	unsigned long	XDM2140 uptime (s)
27	XDM2140 state	unsigned char	XDM2140 state
28	XDM2140 diagnostics status	unsigned char	XDM2140 diagnostics status

Table 45

9.3.7 Parameter Type 0x07 - XDM2140 Information

This parameter is only valid for the Get Parameter command. It is a local request (a packet that is not sent through the network) that retrieves information about the XDM2140's properties.

Parameter Type 0x07 Get Request Details

Message Byte	Description	Data Type	Value
1	Command type	unsigned char	0x89
2	Parameter type	unsigned char	0x07

Table 46

The following packet is sent in response to a request for information about XDM2140 properties

Parameter Type 0x07 Get Response Details

Message Byte	Description	Data Type	Value
1	Command type	unsigned char	140 (0x8A)
2	Parameter type	unsigned char	0x07
3	Error code	unsigned char	Error code
4	Data length	unsigned char	Data length (0x20)
5-7	HW model	Array of 3 unsigned char	Byte 1 = 0x41 Byte 2 = 0x05 to 0x0F Byte 3 = 0x01
8-9	HW revision	Array of 2 unsigned char	HW revision
10-13	SW revision	Array of 4 unsigned char	SW revision
14-21	MAC address	Array of 8 unsigned char	MAC address
22	Networking type	unsigned char	0x04
23-24	Network ID	unsigned short	Network ID
25-32	Datasheet ID	Array of 8 unsigned char	000_0002
33-34	XDM2140 ID	unsigned short	XDM2140 ID
35			Reserved
36	XDM2140 diagnostics status	unsigned char	XDM2140 diagnostics status

Table 47

9.3.8 Parameter Type 0x08 Power Amplifier

This parameter is valid for both the Set Parameter and Get Parameter commands. As a Set Parameter, it sets the power amplifier mode (on/off) on the XDM2140. As a Get Parameter, it retrieves the current power amplifier mode on the XDM2140.

Parameter Type 0x08 Set Request Details

Message Byte	Description	Data Type	Value
1	Command type	unsigned char	0x87
2	Parameter type	unsigned char	0x08
3	Power amplifier mode	unsigned char	0x00 = Turns off power amplifier 0x01 = Turns on power amplifier

Table 48

Parameter Type 0x08 Set Response Details

Message Byte	Description	Data Type	Value
1	Command type	unsigned char	0x88
2	Parameter type	unsigned char	0x08
3	Error code	unsigned char	0x00 = No error 0x01 = Execution error 0x02 = Command format error

Table 49

Parameter Type 0x08 Get Request Details

Message Byte	Description	Data Type	Value
1	Command type	unsigned char	0x89
2	Parameter type	unsigned char	0x08

Table 50

Parameter Type 0x08 Get Response Details

Message Byte	Description	Data Type	Value
1	Command type	unsigned char	0x8A
2	Parameter type	unsigned char	0x08
3	Error code	unsigned char	0x00 = No error 0x01 = Execution error 0x02 = Command format error
4	Data length	unsigned char	0x01
5	Power amplifier mode	unsigned char	0x00 = Power amplifier is off 0x01 = Power amplifier is on

Table 51

9.3.9 Parameter Type 0x0A - Charge Consumption

This parameter is only valid for the Get Parameter command. It retrieves the charge the XDM2140 has consumed since the last reset, the XDM2140 uptime, and XDM2140 temperature.

Parameter Type 0x0A Get Request Details

Message Byte	Description	Data Type	Value
1	Command type	unsigned char	0x89
2	Parameter type	unsigned char	0x0A

Table 52

The following packet is sent in response to a request for information about the XDM2140 charge consumption, XDM2140 uptime, and XDM2140 temperature.

Parameter Type 0x0A Get Response Details

Message Byte	Description	Data Type	Value
1	Command type	unsigned char	140 (0x8A)
2	Parameter type	unsigned char	0x0A
3	Error code	unsigned char	Error code
4	Data length	unsigned char	Data length (0x0E)
5-8	Charge since last reset	unsigned long	Charge (mC)
9-12	Uptime since last reset	unsigned long	Uptime (s)
13-14	Temperature	unsigned short	Temperature (°C)
15-18	Reserved	unsigned long	Reserved

Table 53

9.3.10 Parameter Type 0x0B - Power Source

This command allows the user to set and get the power source configuration of the XDM2140. These values are sent to the Gateway and are taken in consideration during link allocation. When a XDM2140 is designated as *low power*, the XDM2140 will operate in an ultra low-power state. When in this state, the XDM2140 will not advertise for neighbors, and the Gateway will not assign children to the XDM2140. This parameter is valid for both the Set Parameter and Get Parameter commands. Upon receiving this request, the XDM2140 stores the new setting in its persistent storage. The XDM2140 must be reset in order to begin using the new setting.

Parameter Type 0x0B Set Request Details

Message Byte	Description	Data Type	Value
1	Command type	unsigned char	0x87
2	Parameter type	unsigned char	0x0B
3	Power source	unsigned char	0x00 = powered 0x01 = AA L91 0x03 = low power 0x0F = unknown

Table 54

Parameter Type 0x0B Set Response Details

Message Byte	Description	Data Type	Value
1	Command type	unsigned char	0x88
2	Parameter type	unsigned char	0x0B
3	Error code	unsigned char	Error code
4	Data length	unsigned char	0x00

Table 55

Parameter Type 0x0B Power Source Get Request Details

Message Byte	Description	Data Type	Value
1	Command type	unsigned char	0x89
2	Parameter type	unsigned char	0x0B

Table 56

Parameter Type 0x0B Get Response Details

Message Byte	Description	Data Type	Value
1	Command type	unsigned char	0x8A
2	Parameter type	unsigned char	0x0B
3	Error code	unsigned char	Error code
4	Data length	unsigned char	0x01
5	Power source	unsigned char	0x00 = powered 0x01 = AA L91 0x03 = low power 0x0F = unknown

Table 57

9.4 HDLC Packet Examples

Example 1: Constructing an HDLC packet to send to the XDM2140

This example demonstrates how you would construct an HDLC packet to set the network ID value to 00 7D. (All values are in hexadecimal.)

Step 1 Define HDLC packet payload:

Command type => 87
 Parameter => 01
 Network ID => 00 7D

HDLC Packet Payload	
Command Type	Message Content
87	01 00 7D

Table 58

Step 2 Calculate FCS:

- Calculate the FCS using FCS-16 algorithm (RFC 1662) on the hexadecimal sequence '87 01 00 7D'.
 The FCS (including 1's complement) is 74 2F.
- Append FCS to payload, FCS is sent least significant byte first (RFC 1662):

HDLC Packet Payload	FCS
87 01 00 7D	2F 74

Table 59

Step 3 Perform byte stuffing:

To perform byte stuffing, check the HDLC Packet Payload and FCS for instances of "7D" or "7E" and replace as follows:

7D => 7D 5D

7E => 7D 5E

Note that the additional control bytes do not count against the message payload limit defined in Section 9.2.

HDLC Packet Payload (stuffed)	FCS (stuffed)
87 01 00 7D 5D	2F 74

Table 60

- #### Step 4 Add start and stop delimiters:
- Enclose the above in start/stop flags (RFC 1662).

Start Byte	HDLC Packet Payload (stuffed)	FCS (stuffed)	Stop Byte
7E	87 01 00 7D 5D	2F 74	7E

Table 61

Or simply, the hexadecimal sequence:

7E 87 01 00 7D 5D 2F 74 7E

Example 2: Decoding an HDLC packet received from the XDM2140

To understand how to decode an HDLC packet sent from the XDM2140, let us assume that the XDM2140 received a Get command with a parameter of XDM2140 information (see Section 9.3.7), and replied with the following HDLC Packet. (All values are in hexadecimal.)

Start Byte	HDLC Packet Payload (stuffed)	FCS (stuffed)	Stop Byte
7E	8A 07 00 20 00 00 5B 00 01 01 06 00 3C 00 00 00 00 00 00 7D 5E C3 02 00 08 30 30 30 5F 45 56 30 31 00 13 00 00	3E 30	7E

Table 62

Step 1 (HDLC layer) strip off delimiters:

HDLC Packet Payload (stuffed)	FCS (stuffed)
8A 07 00 20 00 00 5B 00 01 01 06 00 3C 00 00 00 00 00 00 7D 5E C3 02 00 08 30 30 30 5F 45 56 30 31 00 13 00 00	3E 30

Table 63

Step 2 Remove byte stuffing:

To remove byte stuffing, check for instances of “7D 5D” or “7D 5E” and replace as follows:

7D 5D => 7D
7D 5E => 7E

HDLC Packet Payload	FCS
8A 07 00 20 00 00 5B 00 01 01 06 00 3C 00 00 00 00 00 00 7E C3 02 00 08 30 30 30 5F 45 56 30 31 00 13 00 00	3E 30

Table 64

Step 3 Confirm FCS:

Calculate the checksum for the HDLC payload.

HDLC Packet Payload
8A 07 00 20 00 00 5B 00 01 01 06 00 3C 00 00 00 00 00 00 7E C3 02 00 08 30 30 30 5F 45 56 30 31 00 13 00 00

Table 65

Confirm that the FCS matches the FCS sent with the packet. Because the packet encodes FCS least significant byte first, in this example the calculated FCS should match “30 3E”.

Step 4 (Application layer) parse HDLC payload content:

The resulting packet payload is as follows:

HDLC Packet Payload
8A 07 00 20 00 00 5B 00 01 01 06 00 3C 00 00 00 00 00 00 7E C3 02 00 08 30 30 30 5F 45 56 30 31 00 13 00 00

Table 66

or

Command Type	Message Content
8A	07 00 20 00 00 5B 00 01 01 06 00 3C 00 00 00 00 00 00 7E C3 02 00 08 30 30 30 5F 45 56 30 31 00 13 00 00

Table 67

As described in Section 9.3.7, an 0x8A command with parameter type 0x07 has the following message content structure:

Param	Error Code	Length	HW Model	HW Rev	SW Rev	MAC	HW Type	Net ID	Datasheet ID	HW ID	Rsvd	Status
07	00	20	00 00 5B	00 01	01 06 00 3C	00 00 00 00 00 00 7E C3	02	00 08	30 30 30 5F 45 56 30 31	00 13	00	00

Table 68

This is a XDM2140 information response with no errors. and a payload length of 32 bytes. The XDM2140 information is as follows (this is an example; actual values will vary, see Section 9.3.7).

HW Model	00091	(00 00 5B)
HW Revision	001	(00 01)
SW Revision	1.6.60	(01 06 00 3C)
MAC Address	00 00 00 00 00 00 7E 3C	
HW (XDM2140) Type	02 = 2.4 GHz	(02)
Network ID	8	(00 08)
Datasheet ID	000_EV01	(30 30 30 5F 45 56 30 31)
HW (XDM2140) ID	19	(00 13)
XDM2140 Diagnostics Status	0	(00)

Table 69

10.0 XDM2140 Outline Drawings

10.1 XDM2140P Pinned Configuration

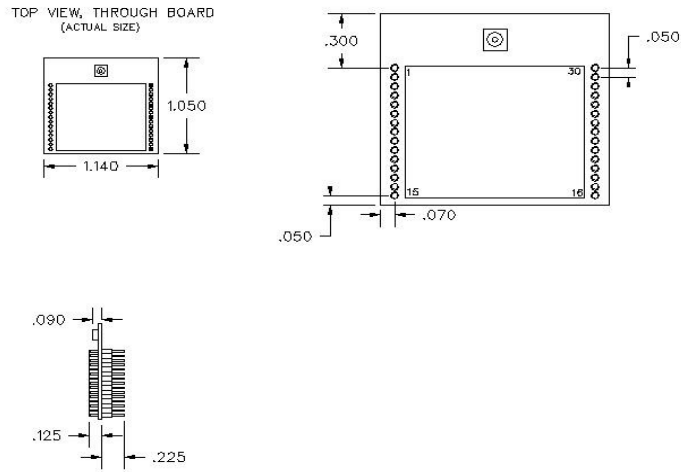

Figure 9

10.2 XDM2140C Castellated Pad Configuration

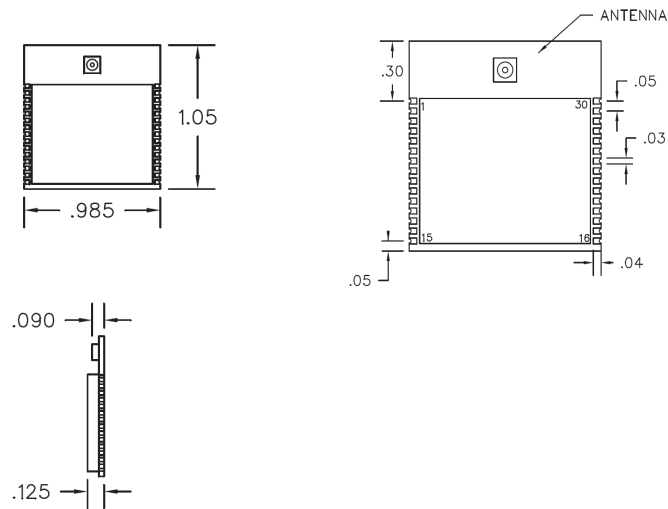

Figure 10