



A Tradition In Testing Services

**Part 15, Class A Verification Report
Emissions Test Report
of the
Digital Wireless Corporation
HopNet HN-1500
Issue Date: August 5, 1998
UST Project No. 98-300**

Total Number of Pages Contained Within This Report: 21



A Tradition In Testing Services

I certify that I am authorized to sign for the manufacturer and that all of the statements in this report and in the Exhibits attached hereto are true and correct to the best of my knowledge and belief:

UNITED STATES TECHNOLOGIES, INC. (AGENT RESPONSIBLE FOR TEST):

By: 

Name: Timothy R. Johnson

Title: Lab Manager

Date: August 5, 1998

Digital Wireless Corporation
One Meca Way
Norcross, GA 30093

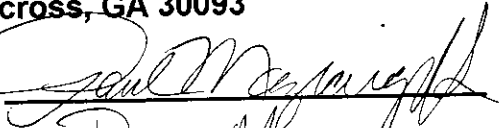
By: 

Name: PAUL MAZIARCZYK

Title: SR. ELECTRONIC TECH

Date: 8-31-98

This report shall not be reproduced except in full. This report may be copied in part only with the prior written approval of U.S. Technologies. The results contained in this report are subject to the adequacy and representative character of the sample provided.



FCC CLASS A LABELING INFORMATION

MANUAL

(a) For a Class A digital device or peripheral, the user instructions must include the following or similar statement, placed in a prominent location in the text of the manual:

NOTE: This equipment has been tested and found to comply with the limits for a Class A digital device, pursuant to Part 15 of the FCC Rules. These limits are designed to provide reasonable protection against harmful interference when the equipment is operated in a commercial environment. This equipment generates, uses, and can radiate radio frequency energy and, if not installed and used in accordance with the instruction manual, may cause harmful interference to radio communications. Operation of this equipment in a residential area is likely to cause harmful interference in which case the user will be required to correct the interference at his own expense.

15.21 INFORMATION TO USER

The users manual or instruction manual for an intentional or unintentional radiator shall caution the user that changes or modifications not expressly approved by the party responsible for compliance could void the user's authority to operate the equipment.

15.27 SPECIAL ACCESSORIES

Accessory items that can be readily obtained from multiple retail outlets are not considered to be special accessories and are not required to be marketed with the equipment. The manual included with the equipment must specify what additional components or accessories are required to be used in order to ensure compliance (i.e. shielded cables), and it is the responsibility of the user to provide and use those components and accessories.

15.19 LABELING REQUIREMENTS

This device shall bear the following statement in a conspicuous location on the device:

LABEL

This device complies with Part 15 of the FCC Rules. Operation is subject to the following two conditions: (1) This device may not cause harmful interference, and (2) this device must accept any interference received, including interference that may cause undesired operation.

NOTICE TO CUSTOMERS SELLING DIGITAL DEVICES IN CANADA

CANADIAN MANDATORY EMI REGULATION

As of January 31, 1989, Canada has implemented mandatory EMI regulations which apply to every digital apparatus manufactured or imported into Canada as of January 31, 1989.

The technical requirements of the Canadian regulations are equivalent to the US FCC Part 15 and Canada will accept tests performed using the ANSI C63.4 procedure. Equipment compliant with FCC Part 15 is also compliant with the Canadian regulation. Canada does require a label be placed on equipment. Where because of insufficient space or other restrictions it is not feasible to affix a label to the apparatus, the notice may be in the form of a statement included in the user's manual.

The device shall bear the following statement in a conspicuous location:

"This (Class A/Class B)* digital apparatus meets all requirements of the Canadian Interference Causing Equipment Regulations."

"Cet appareil numérique (de la classe A/de la classe B)* respecte toutes les exigences du Règlement sur le matériel brouilleur du Canada."

It is recommended that the label be in both French and English, especially in French speaking areas of Canada.

*Indicate only the class of digital apparatus which is appropriate for the specific application.

NOTICE FOR PRODUCTS WHICH CONTAIN A PREVIOUSLY APPROVED MODULAR TRANSMITTER/TRANSCIVER

In some cases, Industry Canada may require additional information regarding your approved transmitter/transceiver. If your company requires assistance with submittal of any information, please contact U.S. Tech at (770)740-0717.

EXHIBIT A EVALUATION REPORT

A. DESCRIPTION OF EQUIPMENT UNDER TEST (EUT):

The Equipment Under Test (EUT) is the Digital Wireless Corporation HopNet HN-1500. The HopNet HN-1500 product is a 2.4 GHz frequency hopping wireless data modem intended for demanding wireless data systems integration projects. The products feature high data rates (250 Kbps over-the-air) and long range (over 10 miles) using HopNet external gain antennas.

The HN-1500 supports up to 255 remotes on a single network, with up to 16 different networks in the same area. The HN-1500 can usually transmit over a range of 500 to 1000 feet indoors with obstructions. You can extend this range by adding a HopNet Repeater (HN-2000).

Automatic repeat request (ARQ) and multinode protocol are transparent to the user equipment. User data rates of 115 Kbps are supported with built-in CRC/ARQ error protocols. Data signals are EIA RS-232 standard for Data Communications Equipment (DCE) devices.

Data and control of the radio are passed through a standard DB9 connector.

B. TEST PROCEDURE (GENERAL):

The EUT was verified as a digital device only to 47 CFR 15 (FCC Part 15, Class A). The transceiver portion of the EUT was not evaluated, and must be considered for full compliance of the product.

The EUT was configured as shown in the following block diagram(s) and photograph(s). The sample was tested per ANSI C63.4, Methods of Measurement from Low-Voltage Electrical and Electronic Equipment in the Range of 9 kHz to 40 GHz (1992). Conducted and radiated emissions data were taken with the test receiver or spectrum analyzer's resolution bandwidth adjusted to 9 kHz and 120 kHz, respectively. All measurements are peak unless stated otherwise. The video filter on the spectrum analyzer was OFF throughout the evaluation process. Interconnecting cables were manipulated as necessary to maximize emissions. Table A4 describes other instruments and accessories used to evaluate this product.

C. CHARACTERIZATION OF SAMPLE TESTED

The sample used for testing was received by U.S. Technologies on July 7, 1998 in good condition.

D. EUT ELECTRICAL MODE OF OPERATION

The primary mains voltage was 120 VAC 60 Hz.

E. TEST SOFTWARE

Not Applicable

F. TEST SITE:

Testing was performed at US Tech's measurement facility at 3505 Francis Circle, Alpharetta, GA. This site has been fully described and submitted to the FCC, and accepted in their letter marked 31040/SIT.

G. MODIFICATIONS:

No modifications were necessary to bring the EUT into compliance with FCC Rules and Regulations.

H. TEST RESULTS:

The worst-case radiated emission was 4.4 dB below the limit at 200.0 MHz. All other radiated emissions were at least 6.6 dB below the limit.

The worst-case line conducted emission was 20.0 dB below the limit at 0.73 MHz. All other conducted emissions were at least 21.0 dB below the limit.

TEST DATE: July 12 & 13, 1998
UST PROJECT: 98-300
CUSTOMER: Digital Wireless Corporation
MODEL: HopNet HN-1500

Configuration of Tested System

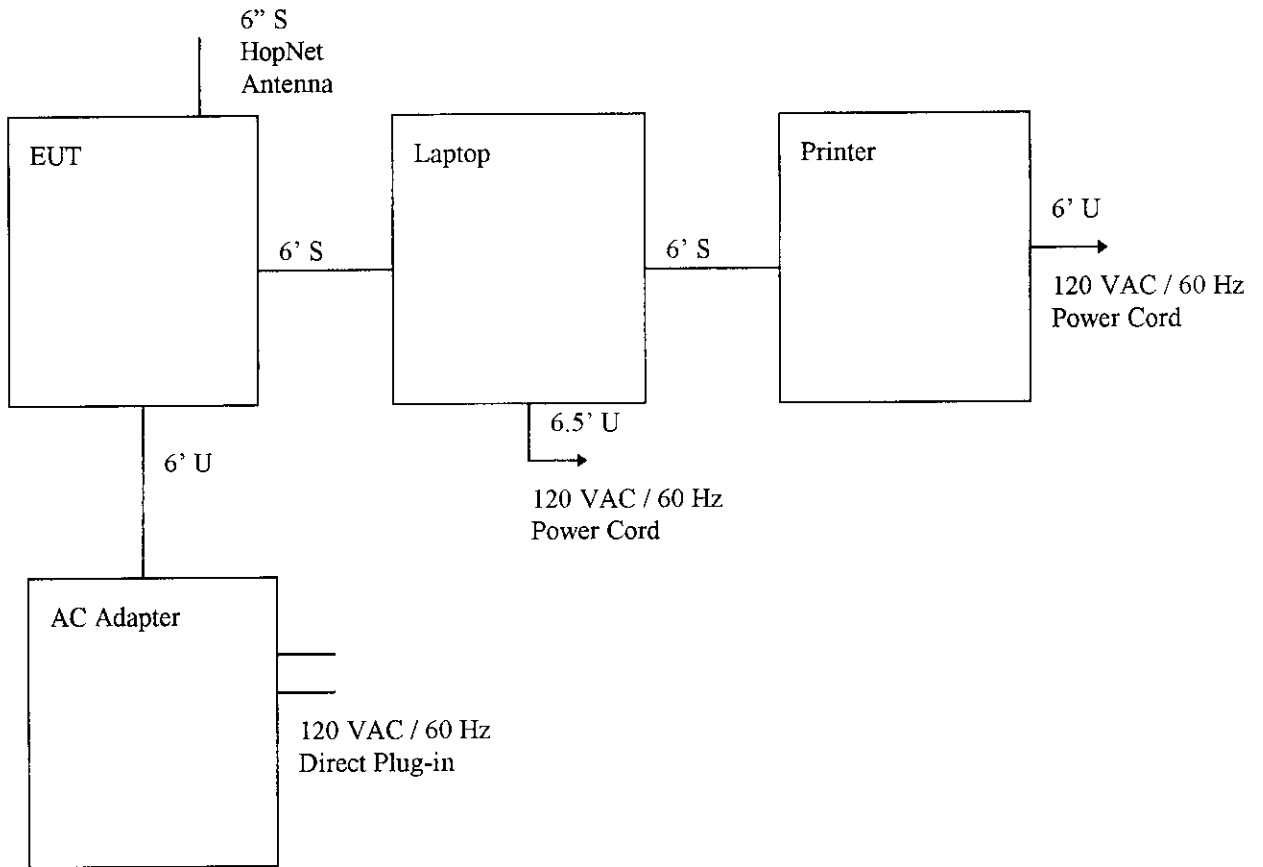

TEST DATE: July 12 & 13, 1998
UST PROJECT: 98-300
CUSTOMER: Digital Wireless Corporation
MODEL: HopNet HN-1500

EUT and Peripherals

PERIPHERAL MANU.	MODEL NUMBER	SERIAL NUMBER	FCC ID:	CABLES P/D
EUT Digital Wireless Corporation	HopNet HN-1500	None	HSW-HN1500 (Pending)	6" S HopNet Antenna
AC Adapter Voltek Kaga Components	91-49275	S-8313A	None	6' U
Laptop Compaq Computer Corp.	LTE ELITE 4/75C Series 2850	6524HPA6E241	CNT75MB1C	6' S 6.5" U Power Cord
Printer Panasonic	KX-P1180	OFKARQ42612	ACJ5Z6KX- P1180	6' S 6' U Power Cord

TABLE A1. RADIATED EMISSIONS DATA

CLASS A

TEST DATE: July 12, 1998
 UST PROJECT: 98-300
 CUSTOMER: Digital Wireless Corporation
 MODEL: HopNet HN-1500

FREQ. (MHz)	TEST DATA (dBm) @ 10m	ANTENNA FACTOR + CABLE ATTEN.	RESULTS (dBuV/m) @ 10m	LIMITS (dBuV/m) @ 10m	MARGIN BELOW LIMIT (dB)
54.4	-86.0	11.5	42.0	90.0	6.6
55.2	-86.0	11.4	41.9	90.0	6.6
87.2	-86.0	11.7	43.0	90.0	6.4
87.9	-87.0*	11.7	38.4	90.0	7.4
200.0	-82.0*	14.1	90.2	150.0	4.4
224.0	-91.0	14.0	31.6	210.0	16.4

* = Quasi-Peak

SAMPLE CALCULATIONS:

RESULTS $\mu\text{V/m}$ @ 10m =

Antilog $((-86.0 + 11.5 + 107)/20) = 42.0$

CONVERSION FROM dBm TO dBuV = 107 dB

Tested by
Signature:

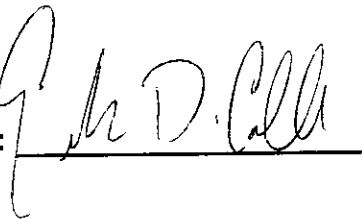

Name: Erik D. Collins

TABLE A2. CONDUCTED EMISSIONS DATA

CLASS A

TEST DATE: July 13, 1998
 UST PROJECT: 98-300
 CUSTOMER: Digital Wireless Corporation
 MODEL: HopNet HN-1500

FREQ. (MHz)	TEST DATA (dBm)		RESULTS (uV)		FCC LIMITS (uV)	MARGIN BELOW LIMIT (dB) PHASE	MARGIN BELOW LIMITS (dB) NEUTRAL
	PHASE	NEUTRAL	PHASE	NEUTRAL			
0.73	-67.0	-68.0	100.0	89.1	1000.0	20.0	21.0
1.0	-70.0	-71.0	70.8	63.1	1000.0	23.0	24.0
6.6	-61.0	-63.0	199.5	158.5	3000.0	23.5	25.5
6.9	-61.0	-63.0	199.5	158.5	3000.0	23.5	25.5
14.7	-72.0	-71.0	56.2	63.1	3000.0	34.5	33.5
22.8	-75.0	-75.0	39.8	39.8	3000.0	37.5	37.5

SAMPLE CALCULATIONS:

RESULTS uV =

Antilog $((-67.0 + 107)/20) = 100.0$

CONVERSION FROM dBm TO dBuV = 107 dB

Tested by
 Signature: _____



Name: Erik D. Collins

TABLE A4. INSTRUMENTS AND ACCESSORIES

TYPE	SPECIFICATIONS	MANUFACTURER	MODEL
SPECTRUM ANALYZER	.1- 1300 MHz	HEWLETT-PACKARD	8558B
SPECTRUM ANALYZER	.1 - 1500 MHz	HEWLETT-PACKARD	8558B
SPECTRUM ANALYZER	9 KHz - 22 GHz	HEWLETT-PACKARD	8593E
COMB GENERATOR		HEWLETT-PACKARD	8406A
TEST RECEIVER	20 - 1000 MHz	ROHDE & SCHWARZ	ESV
RF PREAMP	1 - 26.5 GHz	HEWLETT-PACKARD	8449B
LISN 8012-50-R-24-BNC	120V	SOLAR ELE.	8012
BILOG ANTENNA	30 MHz - 2 GHz	CHASE	6112A
BICONICAL ANTENNA	30 MHz - 300 MHz	EMCO	3110
LOG PERIODIC ANTENNA	200 MHz - 1 GHz	EMCO	3146
LISN (x 2) 8028-50-TS24-BNC	600V	SOLAR ELE.	8028

APPENDIX A

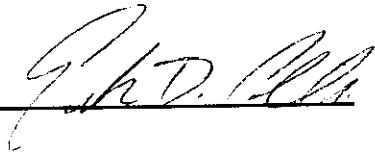
**INCLUDES:
Internal Photographs**

PHOTOS OF TESTED EUT

The following photos are attached:

Photo 1. EUT, Front View

Photo 2. EUT, Front View , Cover Removed

Photo 3. EUT, Rear View, Cover Removed

Photo 4. Internal View, Top Side

Photo 5. Internal View, Bottom Side