



Testing Tomorrow's Technology

**Cirronet
FCC Part 15, Certification Application
WIT2410T Spread Spectrum Transceiver**

**UST Project: 07-0087
Issue Date: May 15, 2007**

**3505 Francis Circle Alpharetta, GA 30004
PH: 770-740-0717 Fax: 770-740-1508
www.ustech-lab.com**



Testing Tomorrow's Technology

I certify that I am authorized to sign for the manufacturer and that all of the statements in this report and in the Exhibits attached hereto are true and correct to the best of my knowledge and belief:

UNITED STATES TECHNOLOGIES, INC. (AGENT RESPONSIBLE FOR TEST):

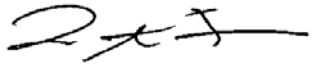
By: 

Name: Louis A. Feudi

Title: Operations Manager

Date: May 15, 2007

Cirronet Corporation
5375 Oakbrook Parkway
Norcross, GA 30093

By: _____

Name: _____

Title: _____

Date: _____

This report shall not be reproduced except in full. This report may be copied in part only with the prior written approval of U.S. Technologies. The results contained in this report are subject to the adequacy and representative character of the sample provided.

3505 Francis Circle Alpharetta, GA 30004
PH: 770-740-0717 Fax: 770-740-1508

www.ustech-lab.com

MEASUREMENT/TECHNICAL REPORT

COMPANY NAME: **Cirronet**
MODEL: **WIT2410T**
FCC ID: **HSW-2410T**
DATE: **May 15, 2007**

This report concerns (check one): Original grant
Class II change

Equipment type: **2.4 GHz Spread Spectrum Transceiver**

Deferred grant requested per 47 CFR 0.457(d)(1)(ii)? yes No

If yes, defer until: _____
date

N.A. agrees to notify the Commission by N.A.
date

of the intended date of announcement of the product so that the grant can be issued on that date.

Report prepared by:

United States Technologies, Inc.
3505 Francis Circle
Alpharetta, GA 30004

Phone Number: (770) 740-0717
Fax Number: (770) 740-1508

TABLE OF CONTENTS

AGENCY AGREEMENT

SECTION 1

GENERAL INFORMATION

- 1.1 Product Description
- 1.2 Related Submittal(s)

SECTION 2

TESTS AND MEASUREMENTS

- 2.1 Configuration of Tested EUT
- 2.2 Test Facility
- 2.3 Test Equipment
- 2.4 Modifications
- 2.5 Antenna Description
- 2.6 Peak Power (Bandedge Antenna Conducted at Antenna Terminal)
- 2.7 Antenna Conducted Spurious Emissions
- 2.8 Peak Radiated Spurious Emissions
- 2.9 Average Radiated Spurious Emissions
- 2.10 Bandedge Requirements
- 2.11 Minimum 20 dB Bandwidth
- 2.12 Number of Hopping Channels
- 2.13 Average Time of Occupancy per Channel
- 2.14 Power Line Conducted Emissions for Transmitter
- 2.15 Radiated Emissions for Digital Device & Receiver
- 2.16 Power Line Conducted for Digital Device & Receiver
- 2.17 Channel Separation

SECTION 3

LABELING INFORMATION

SECTION 4

BLOCK DIAGRAM(S)/ SCHEMATIC(S)

SECTION 5

PHOTOGRAPHS

SECTION 6

THEORY OF OPERATION

SECTION 7

USER'S MANUAL

LIST OF FIGURES AND TABLES

FIGURES

- 1) Test Configuration
- 2) Photograph(s) for Spurious and Conducted Emissions
- 3) Peak Output Power
- 4) Conducted Spurious Emissions
- 5) Peak Radiated Spurious Emissions
- 6) Bandedge Compliance Antenna Conducted
- 7) 20 dB Bandwidth
- 8) Number of Hopping Channels
- 9) Channel Separation

TABLES

- 1) EUT and Peripherals
- 2) Test Instruments
- 3) Peak Power Output
- 4) Peak Radiated Spurious Emissions
- 5) Average Radiated Spurious Emissions
- 6) 20 dB Bandwidth
- 7) Number of Hopping Channels
- 8) Conducted Emissions
- 9) Radiated Emissions for Digital Device and Receiver

SECTION 1

GENERAL INFORMATION

GENERAL INFORMATION

1.1 Product Description

The Equipment Under Test (EUT) is a Cirronet, Model WIT2410T modular 2.4 GHz spread spectrum transceiver. The EUT will be used with one antenna.

1.2 Related Submittal(s)/Grant(s)

The EUT will be used to send/receive data. The transceiver presented in this report will be used with other like transceivers:

The EUT is subject to the following authorizations:

- a) Certification as a transceiver (modular approval)
- b) Verification as a digital device

The information contained in this report is presented for the certification & verification authorization(s) for the EUT. The manufacturer desires to seek a modular approval on this device.

SECTION 2

TESTS AND MEASUREMENTS

TEST AND MEASUREMENTS

2.1 Configuration of Tested System

The sample was tested per ANSI C63.4, Methods of Measurement from Low-Voltage Electrical and Electronic Equipment in the Range of 9 kHz to 40 GHz (2003). Conducted and radiated emissions data were taken with the test receiver or spectrum analyzer's resolution bandwidth adjusted to 9 kHz and 120 kHz, respectively. All measurements are peak unless stated otherwise. The video filter associated with the spectrum analyzer was off throughout the evaluation process. Block diagrams of the tested systems are shown in Figures 1a and 16. Test configuration photographs for spurious and fundamental emissions are shown in Figure 2a -g.

The sample used for testing was received by U.S. Technologies on May 1, 2007 in good condition.

2.2 Test Facility

Testing was performed at US Tech's measurement facility at 3505 Francis Circle, Alpharetta, GA. This site has been fully described and registered with the FCC, under designation number US5117. Additionally this site has also been fully described and submitted to Industry Canada (IC), and has been approved under file number IC2982.

2.3 Test Equipment

Table 2 describes test equipment used to evaluate this product.

2.4 Modifications

No modifications were made by US Tech, to bring the EUT into compliance with FCC Part 15, Class B Limits for the transmitter portion of the EUT or the Class B Digital Device Requirements.

FIGURE 1a
TEST CONFIGURATION

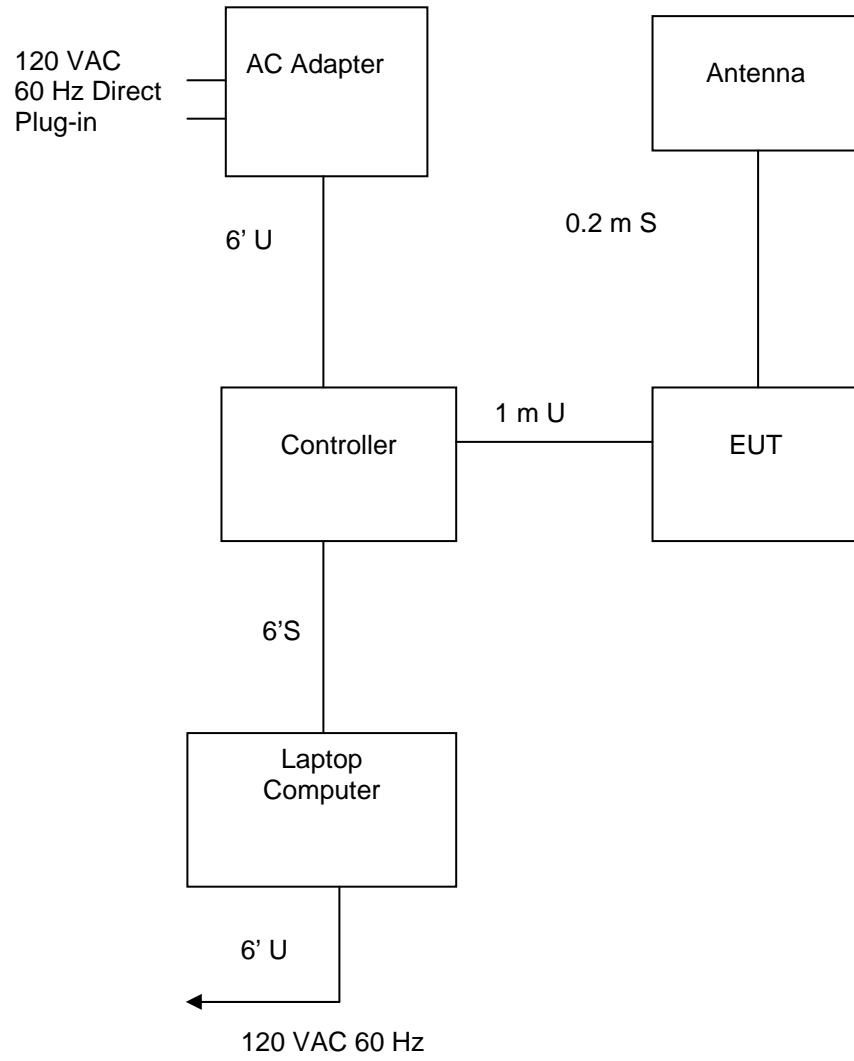

TABLE 1

Test Date: May 1 through 8, 2007
UST Project: 07-0087
Customer: Cirronet
Model: WIT2410T

EUT and Peripherals

PERIPHERAL MANU.	MODEL NUMBER	SERIAL NUMBER	FCC ID:	CABLES P/D
(EUT) Cirronet	WIT2410T	008517	HSW-2410T	1 m U
Antenna see antenna descriptions	MFB2400B	None	None	0.2 m S
AC Adapter Volgen	SPU10R-1	None	None	6' U 120 VAC/ 60 Hz Direct Plug-in
Controller Cirronet	None	None	None	6' S
Laptop Computer Compaq	Armada 7400	7908BXL2036	Not Visible	6' U 120 VAC/ 60 Hz Power Cord

**TABLE 2
TEST INSTRUMENTS**

EQUIPMENT	MODEL NUMBER	MANUFACTURER	SERIAL NUMBER	DATE OF LAST CALIBRATION
SPECTRUM ANALYZER	8593E	HEWLETT-PACKARD	3205A00124	7/03/06
SIGNAL GENERATOR	8648B	HEWLETT-PACKARD	3642U01679	10/13/06
RF PREAMP	8447D	HEWLETT-PACKARD	2944A06291	5/24/06
BICONICAL ANTENNA	3110B	EMCO	9307-1431	10/11/06
LOG PERIODIC	3146	EMCO	3110-3236	9/15/06 2 Yr
LISN (x 2) 8028-50-TS24-BNC	8028	SOLAR ELE.	910494 & 910495	5/10/07
HORN ANTENNA	3115	EMCO	9107-3723	10/16/06
PREAMP	8449B	HEWLETT PACKARD	3008A00480	8/10/06
CALCULATION PROGRAM	N/A	N/A	Ver. 6.0	N/A

Note: The calibration interval of the above test instruments is 12 months unless stated otherwise and all calibrations are traceable to NIST/USA.

2.5 Antenna Description (Paragraph 15.203)

An intentional radiator shall be designed to ensure that no antenna other than that furnished by the responsible party shall be used with the device. The use of a permanently attached antenna or of an antenna that uses a unique coupling to the intentional radiator shall be considered sufficient to comply with the provisions of this section.

Cirronet Corporation will sell the WIT2410T with the following antenna.

MANUFACTURER	TYPE OF ANTENNA	MODEL	GAIN dB	TYPE OR CONNECTOR
Mobile Antennas				
MaxRad	Omni	MFB2400B	8 dBi	Reverse TNC to Reverse N via Cable

To ensure compliance with 15.203, Cirronet Corporation attaches reverse-sex TNC or N connectors to all antennas except the 12 dBi and 6 dBi Patch antennas.

When producing multiple antennas, Cirronet Corporation. has arranged for the manufacturers of the antennas to provide reverse-sex TNC or N connectors for these antennas. OEM customers wanting to use one of these antennas in their product will first need to obtain a special part number from Cirronet Corporation to give to the antenna manufacturer. The manufacturer, upon receipt of this number, will know to attach the reverse-sex TNC or N connector (or SMA in the case of the dipole) to the end of the antenna cable before shipping.

The customer then purchases an adapter cable from Cirronet Corporation that will connect the MMCX port on the module to the reverse-sex connector on the antenna. No other type of commercially available antenna will attach to this reverse-sex TNC or N connector (or SMA for the case of the dipole). Given the nonstandard nature of the interconnect between module and antenna and the difficulty involved in circumventing that connection, Cirronet Corporation feel that this procedure meets the requirements called out in 15.203.

For this evaluation only one antenna is provided or approved for use with the WIT2410T.

2.6 Peak power within the band 2400 – 2483.5 GHz per FCC Section 15.247(b)

Peak power within the band 2400-2483.5 GHz has been measured with a spectrum analyzer by connecting the spectrum analyzer directly via a short cable to the antenna output terminals or across the antenna leads on the PCB as specified by the manufacturer. The spectrum analyzer was set for a 50 Ω impedance with the VBW \geq RBW 6 dB bandwidth. The results of the measurements are given in Table 3 and Figure 3a through Figure 3c.

Fundamental Frequencies were measured at Low Channel, Mid Channel, and High Channel.

**TABLE 3
PEAK POWER OUTPUT**

Test Date: May 1, 2007
UST Project: 07-0087
Customer: Cirronet
Model: WIT2410T

Frequency of Fundamental (MHz)	Measurement (dBm)*	Measurement (mW)*	FCC Limit (Watt)
2401.945	17.92	61.94	1.0
2435.688	17.87	61.24	1.0
2469.8138	18.09	64.27	1.0

* Measurement includes 0.1 dB for cable loss

**Tester
Signature:**



Name: Gersop Riera

Figure 3a.
Peak Power per FCC Section 15.247(b) Low Channel

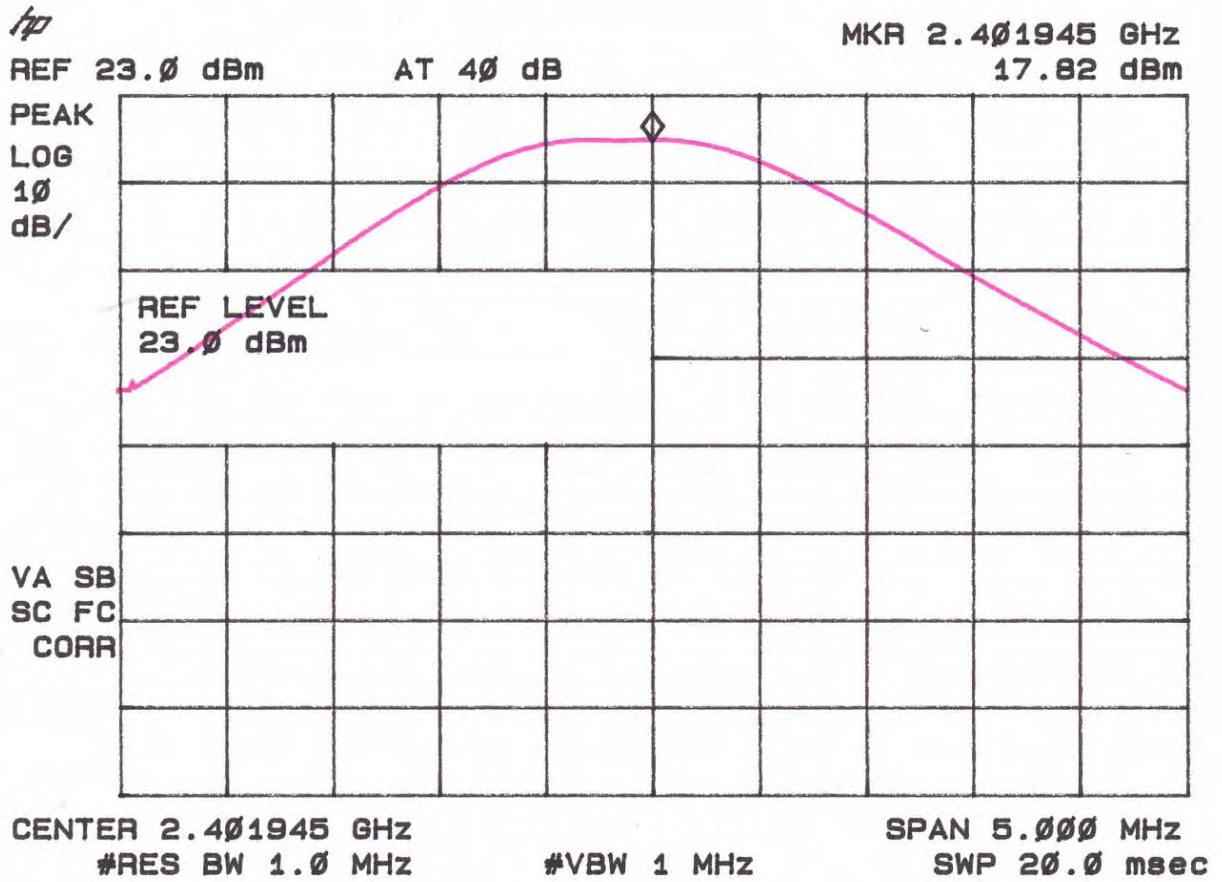

Figure 3b.
Peak Power per FCC Section 15.247(b) Mid Channel

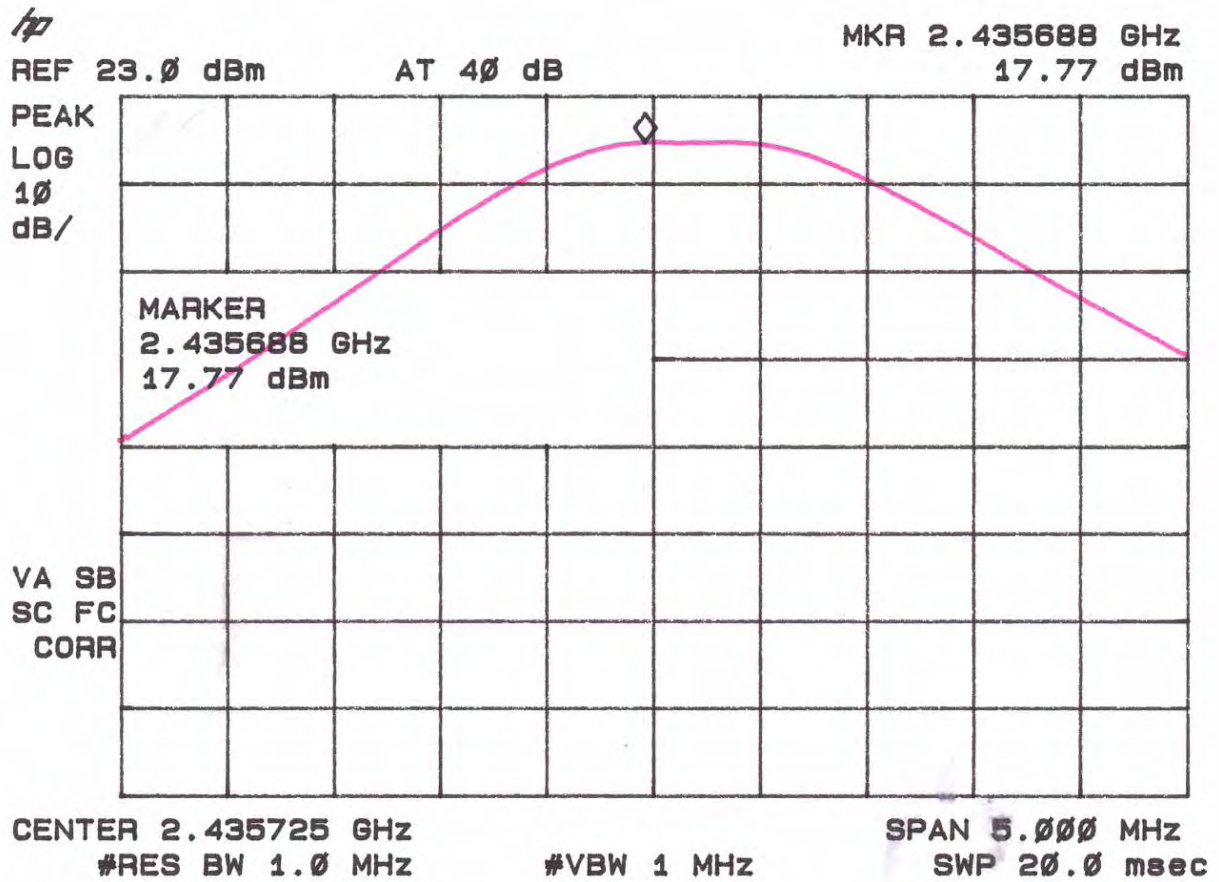
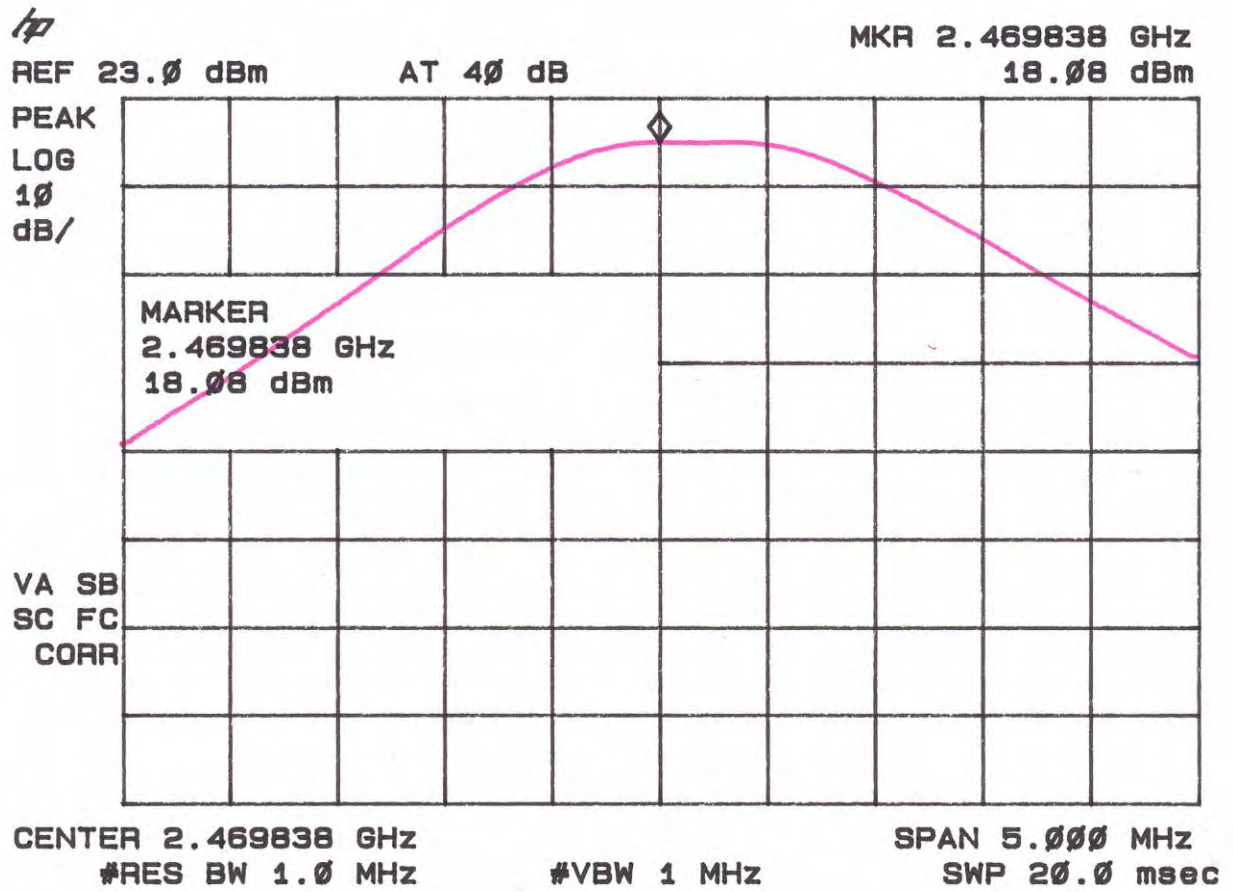

Figure 3c.
Peak Power per FCC Section 15.247(b) High Channel



2.7 Antenna Conducted Spurious Emission the Frequency Range 30 – 25000 MHz (FCC Section 15.247(c))

Spurious emissions in the frequency range 30 – 25000 MHz have been measured with a spectrum analyzer by connecting the spectrum analyzer directly via a short cable to the antenna output terminals or across the antenna leads on the PCB as specified by the manufacturer. The spectrum analyzer was set for a 50 Ω impedance with the RBW = 100 kHz & VBW > RBW. All spurious emissions were measured to be greater than 20 dB down from the fundamental. The results of conducted spurious emissions are given in Figure 4a through 4i.

Figure 4a
Antenna Conducted Spurious Emissions 15.247(c) Low

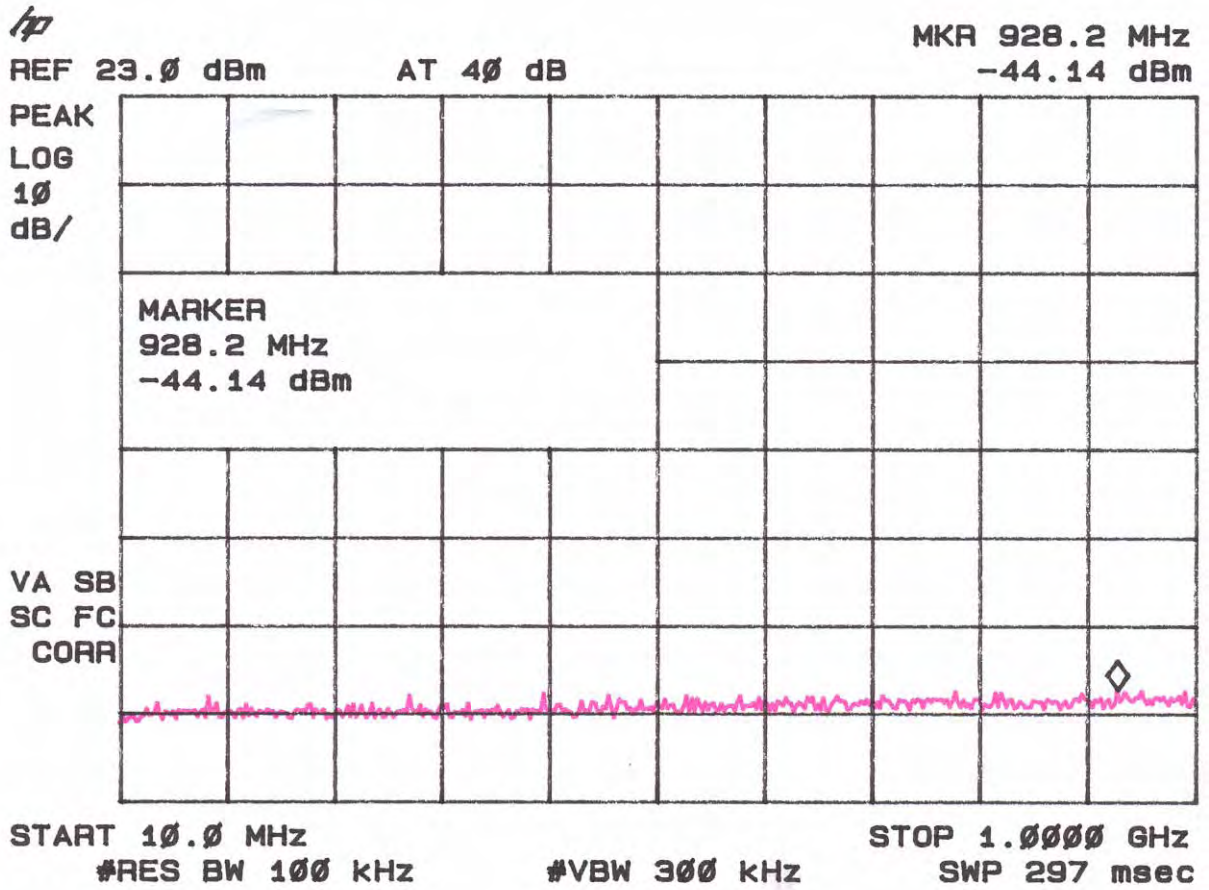
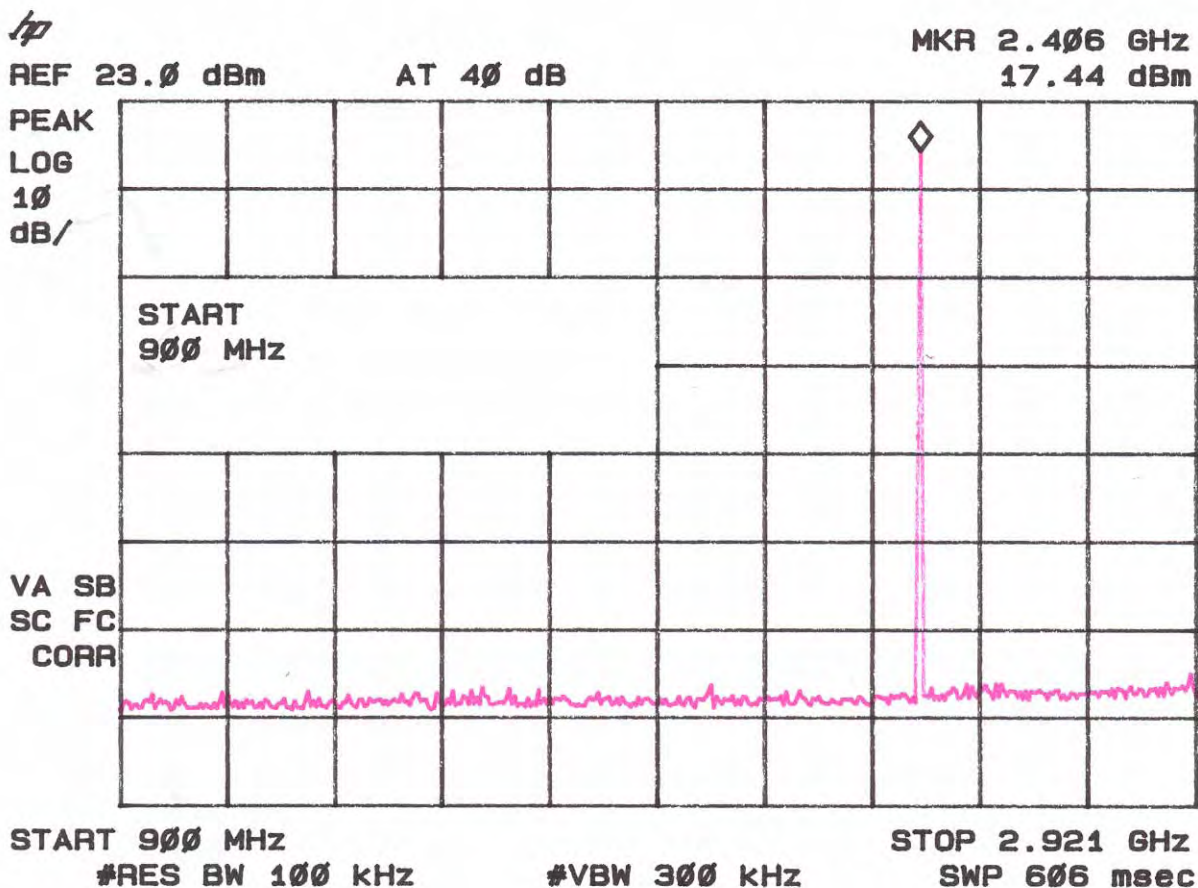

Figure 4b
Antenna Conducted Spurious Emissions 5.247(c) Low



Note: Signal shown represents Fundamental Frequency.

Figure 4c
Antenna Conducted Spurious Emissions 15.247(c) Low

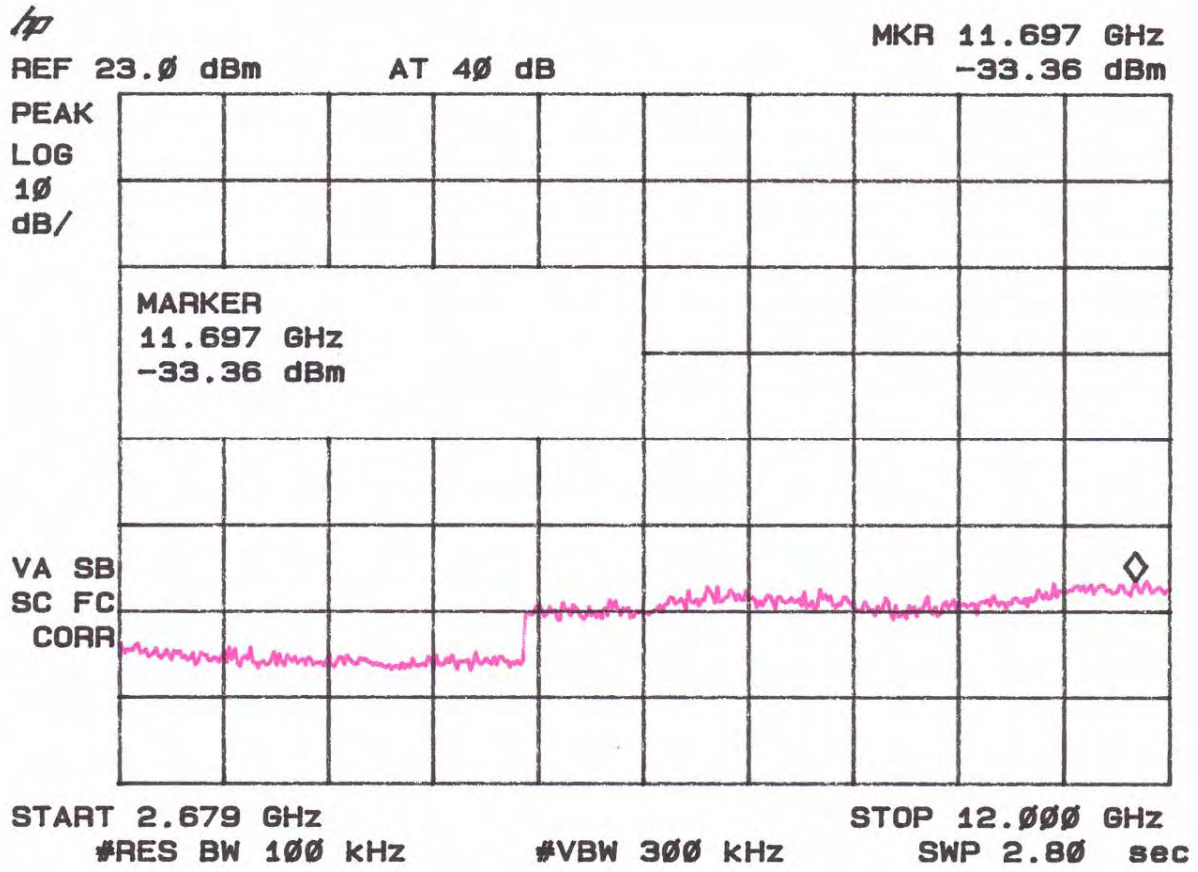

Figure 4d
Antenna Conducted Spurious Emissions 15.247(c) Mid

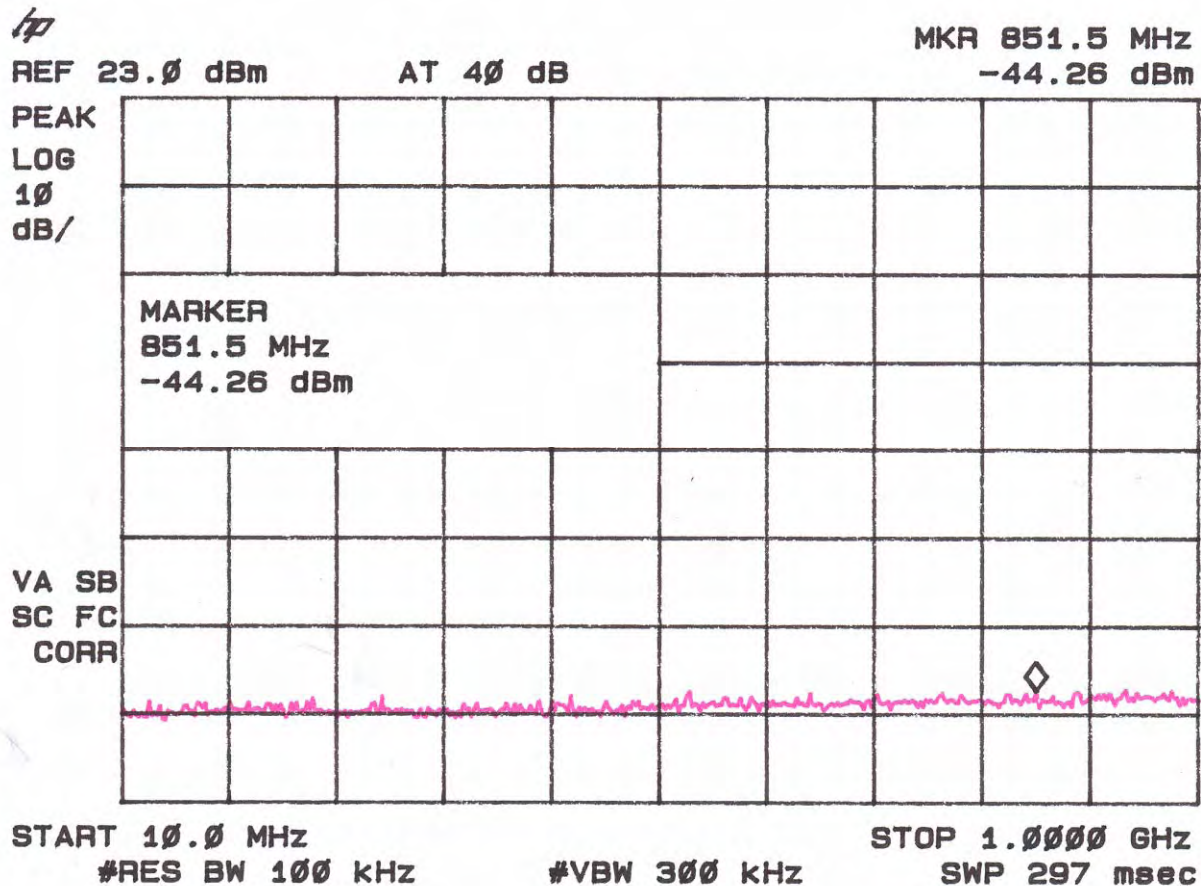
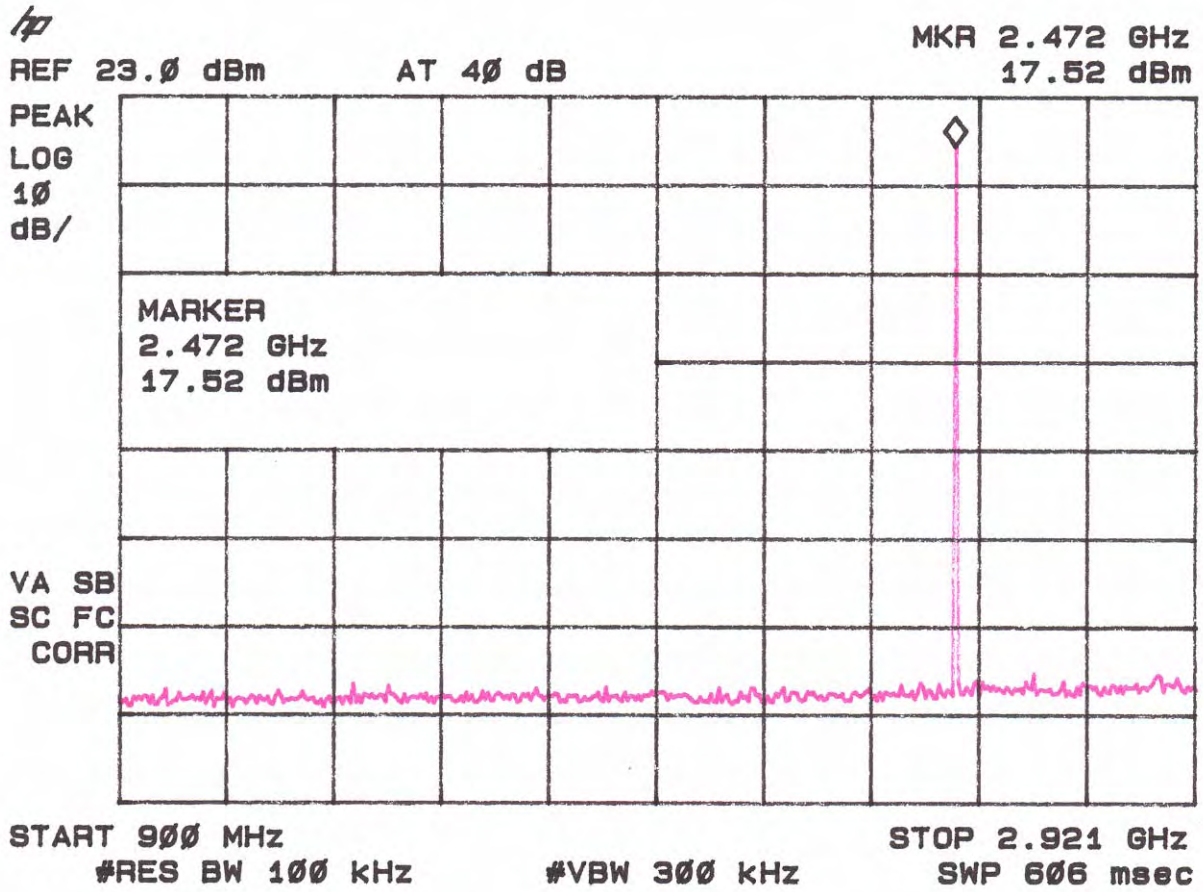

Figure 4e
Antenna Conducted Spurious Emissions 15.247(c) Mid



Note: Signal shown represents Fundamental Frequency.

Figure 4f

Antenna Conducted Spurious Emissions 15.247(c) Mid

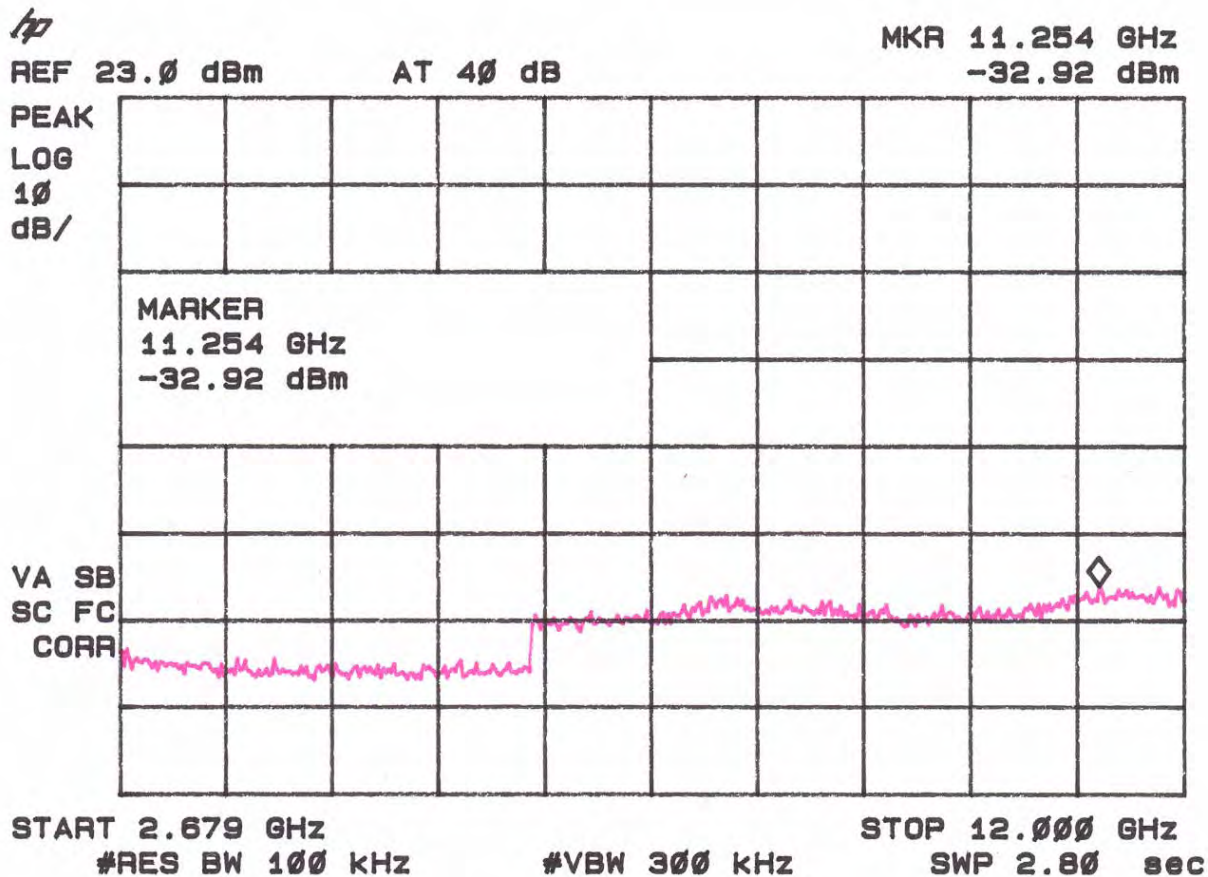

Figure 4g
Antenna Conducted Spurious Emissions 15.247(c) High

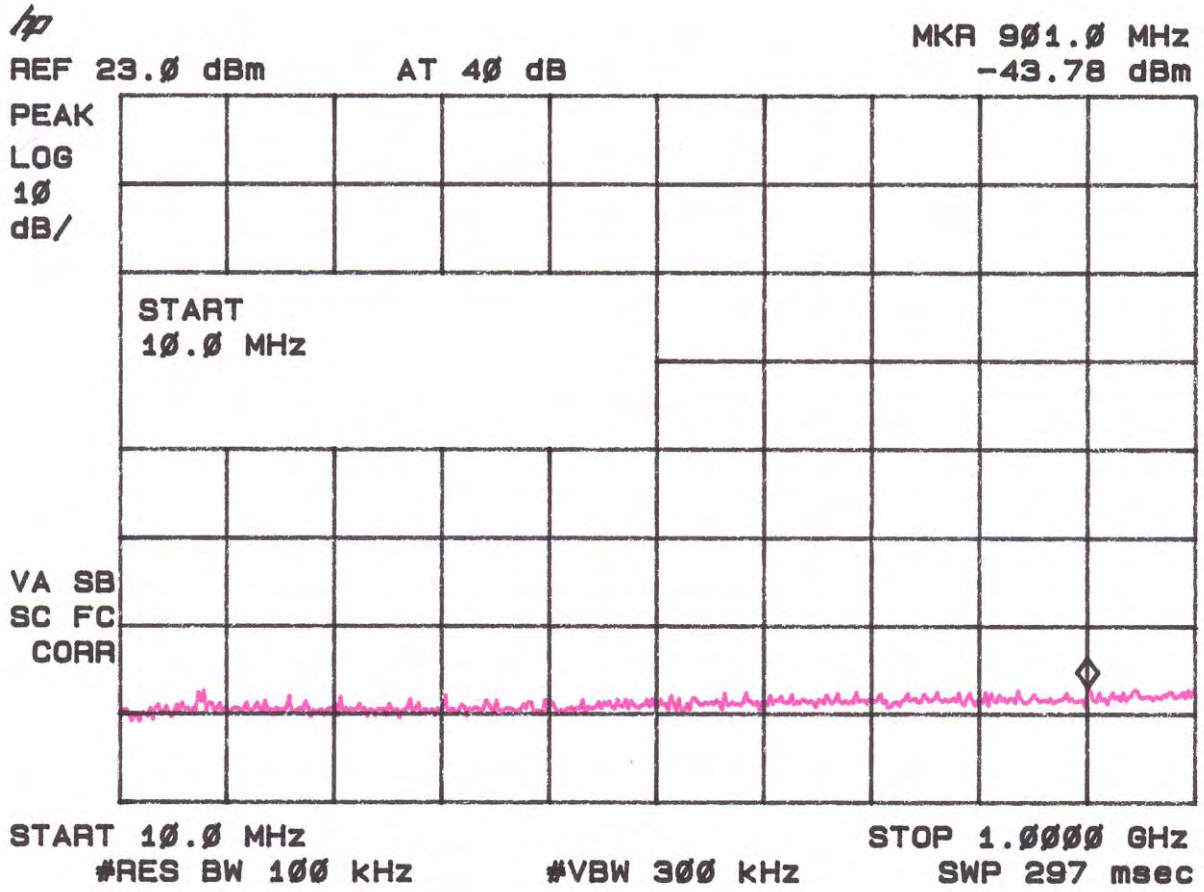
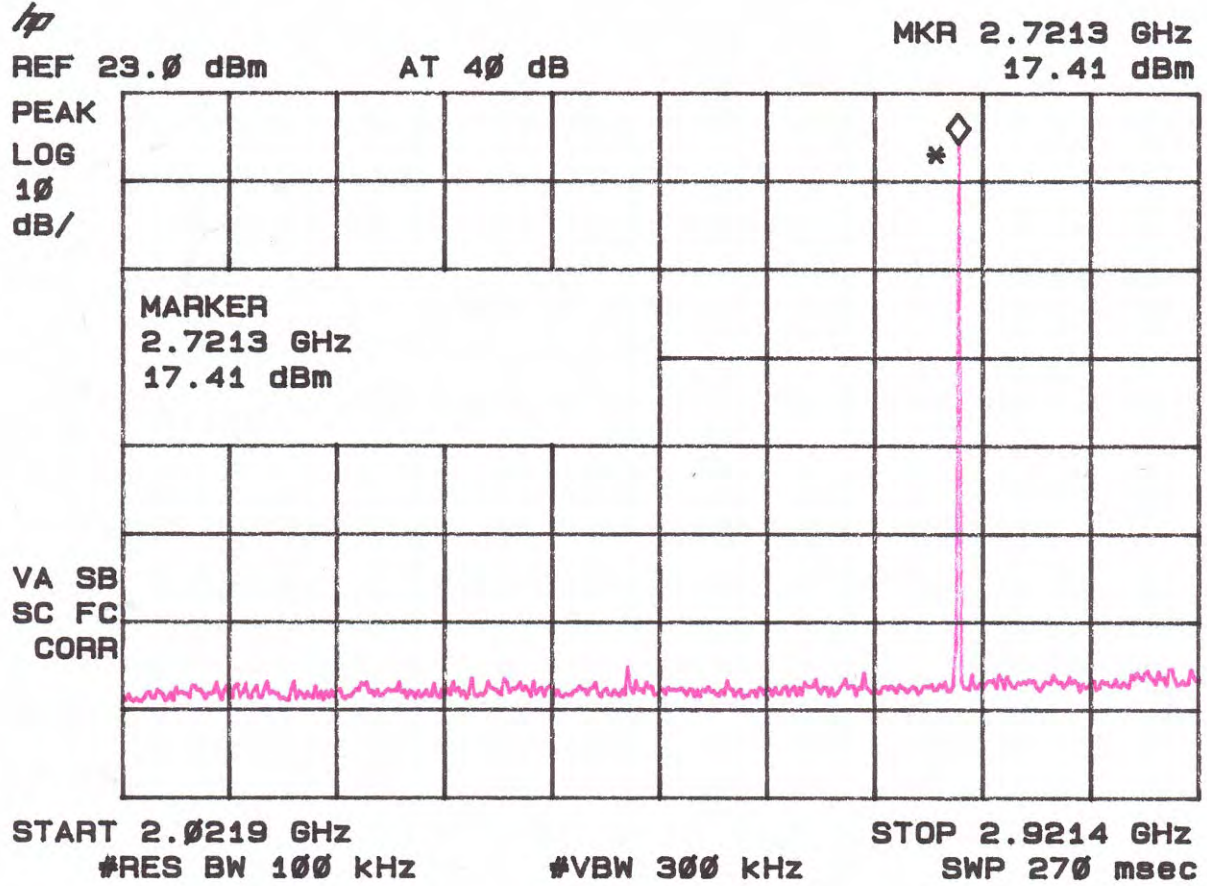
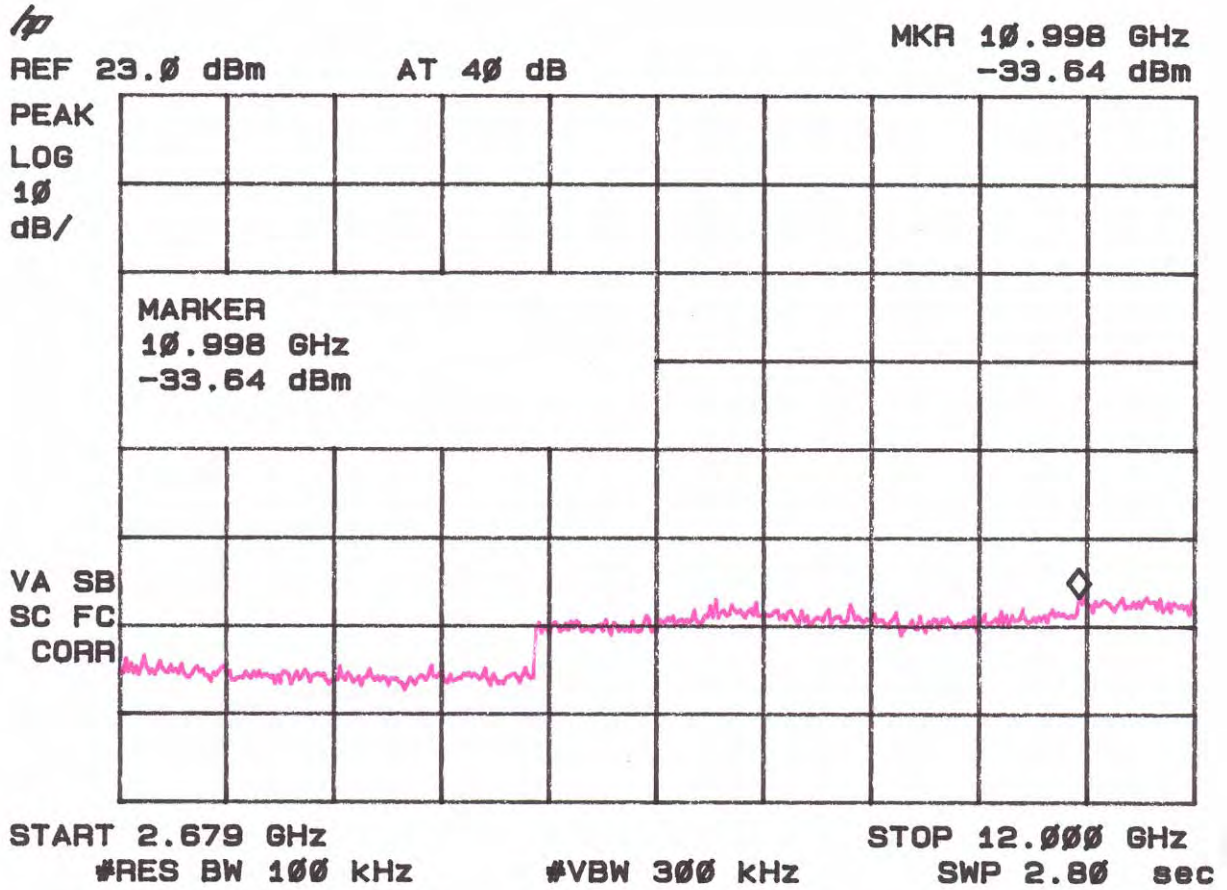

Figure 4h
Antenna Conducted Spurious Emissions 15.247(c) High



Note: Signal shown represents Fundamental Frequency.

Figure 4i
Antenna Conducted Spurious Emissions 15.247(c) High



2.8 Peak Radiated Spurious Emission in the Frequency Range 30 -25000 MHz (FCC Section 15.247(c))

The EUT was hop-stopped and when possible, placed into a continuous transmit mode of operation. A preliminary scan was performed on the EUT to determine frequencies that were caused by the transmitter portion of the product. Significant emissions that fell within restricted bands were then measured on an OAT's site. Radiated measurements below 1 GHz were tested with a RBW = 120 kHz. Radiated measurements above 1 GHz were measured using a RBW = VBW = 1 MHz. The results of peak radiated spurious emissions falling within restricted bands are given in Table 4a –4c and Figure 4a – Figure 4c.

Table 4a. PEAK RADIATED SPURIOUS EMISSIONS (Low)

Radiated Spurious Emissions									
Test By:	Test:	Spurious Emissions- Low Channel				Client:	Cirronet		
GR	Project:	07-0087	Class:	Peak	Model:	WIT2410T			
Frequency (MHz)	Test Data (dBm)	AF Table	Test Data (dBuV)	AF+CA-AMP (dB)	Results (uV/m)	Limits (uV/m)	Distance / Polarity	Margin (dB)	PK / QP
2401.83	-17.4	1HN3mV	89.6	31.9	1187945.9		3m./VERT		PK
4803.063	-57.5	1hn3mv	49.5	5.1	535.8	5000.0	3m./VERT	19.4	PK
7204.813	-45.2	1hn3mv	61.8	9.5	3661.9	118794.6	3m./VERT	30.2	PK
9606.912	-52.6	1hn3mv	54.4	12.9	2312.6	118794.6	3m./VERT	34.2	PK
12008.15	-62.7	1hn3mv	44.3	17.3	1196.5	5000.0	3m./VERT	12.4	PK

Data corrected by 0.1 dB for loss of high pass filter, except to fundamental

** Conversion from 1 meter to 3 meters = -9.54 dB

SAMPLE CALCULATION:

RESULTS (uV/m @ 3m) = Antilog ((-57.5 + 5.1 + 107)/20) = 535.8

CONVERSION FROM dBm TO dBuV = 107 dB

Tester

Signature: 

Name: Gersop Riera

Figure 4a - 1
Peak Radiated Spurious Emission 15.247(c) Fundamental Low

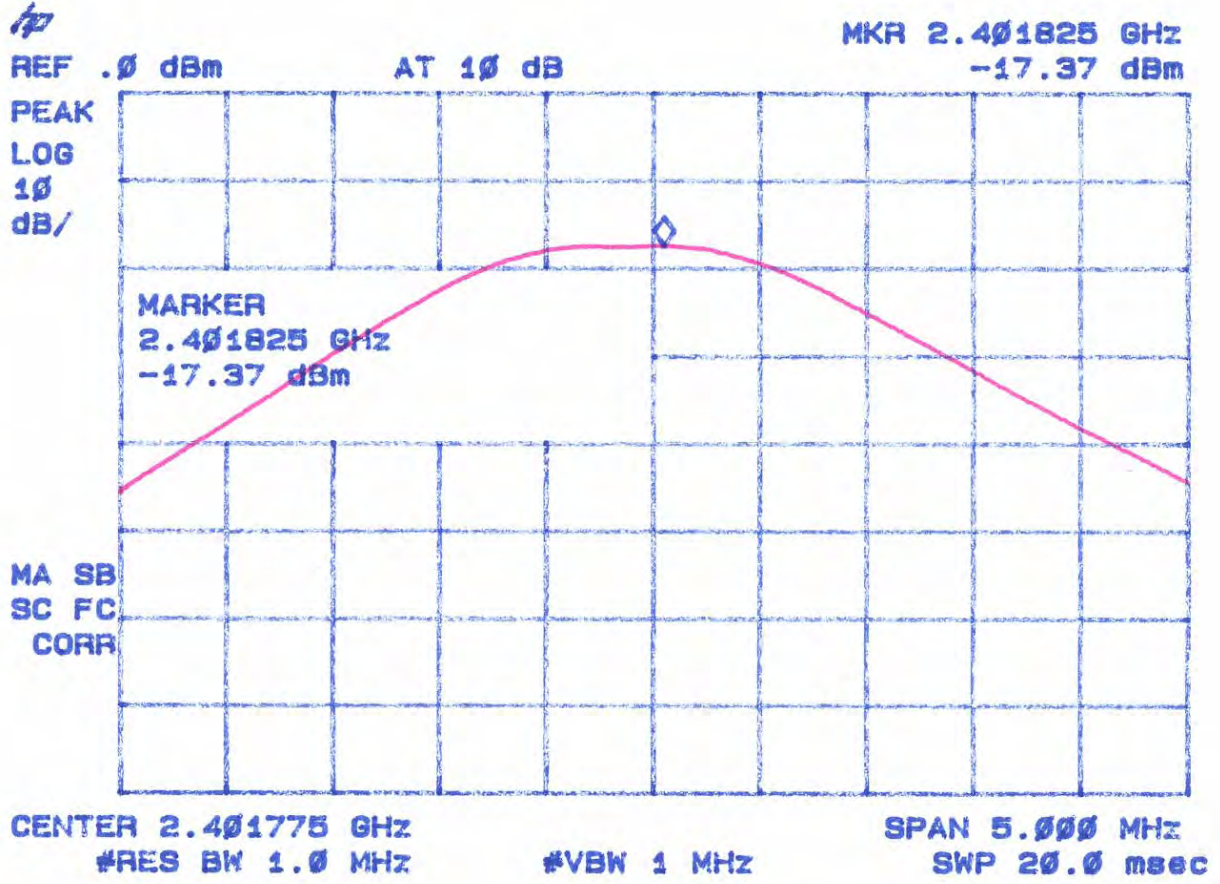

Figure 4a - 2
Peak Radiated Spurious Emission 15.247(c) Low

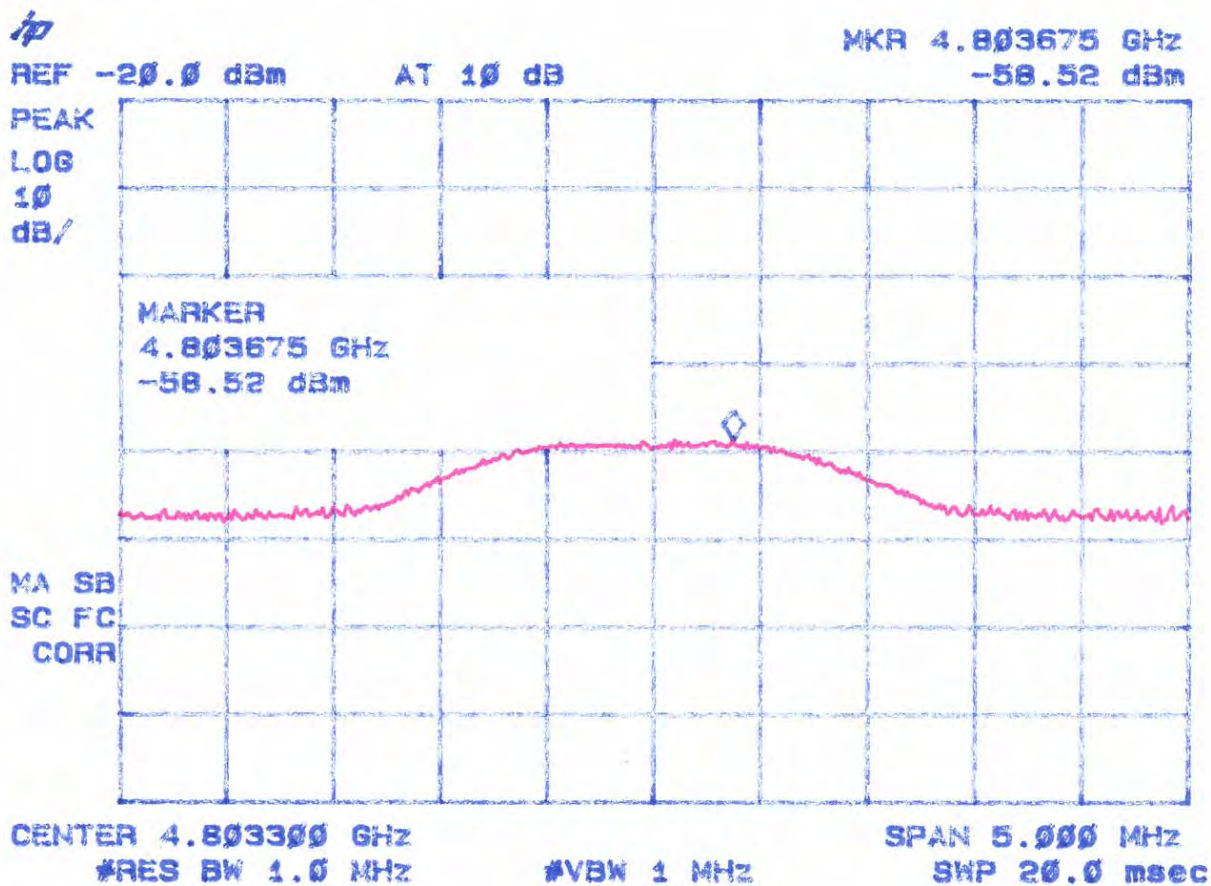

Figure 4a - 3
Peak Radiated Spurious Emission 15.247(c) Low

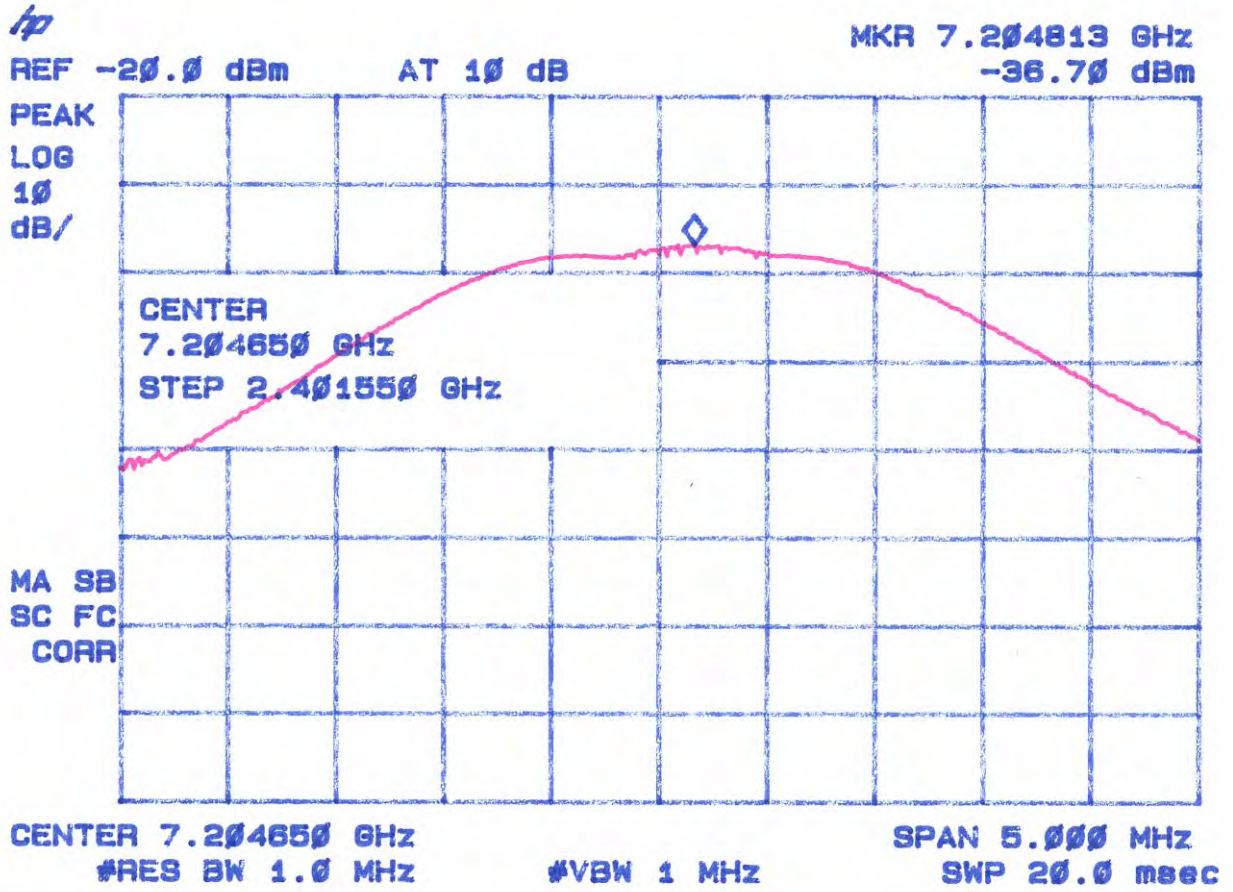

Figure 4a - 4
Peak Radiated Spurious Emission 15.247(c) Low

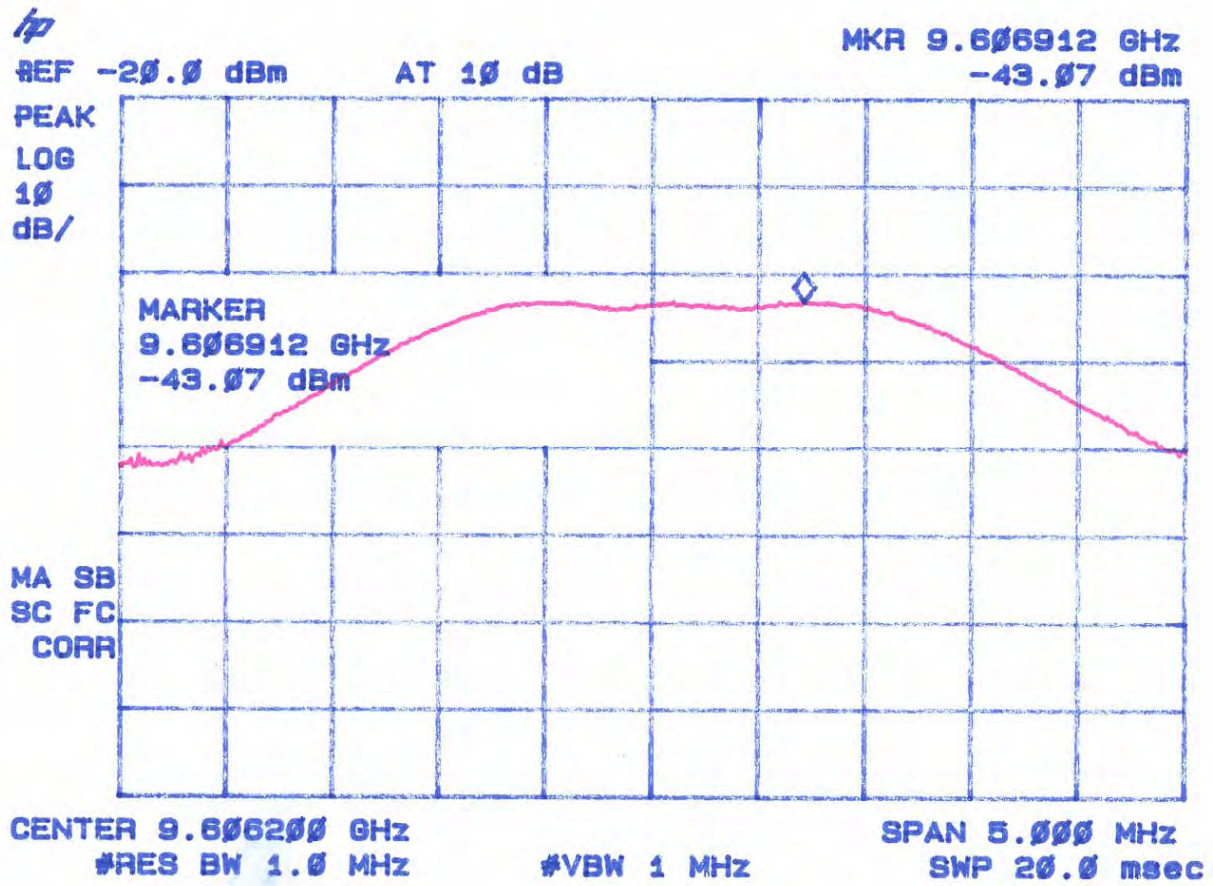

Figure 4a - 5
Peak Radiated Spurious Emission 15.247(c) Low

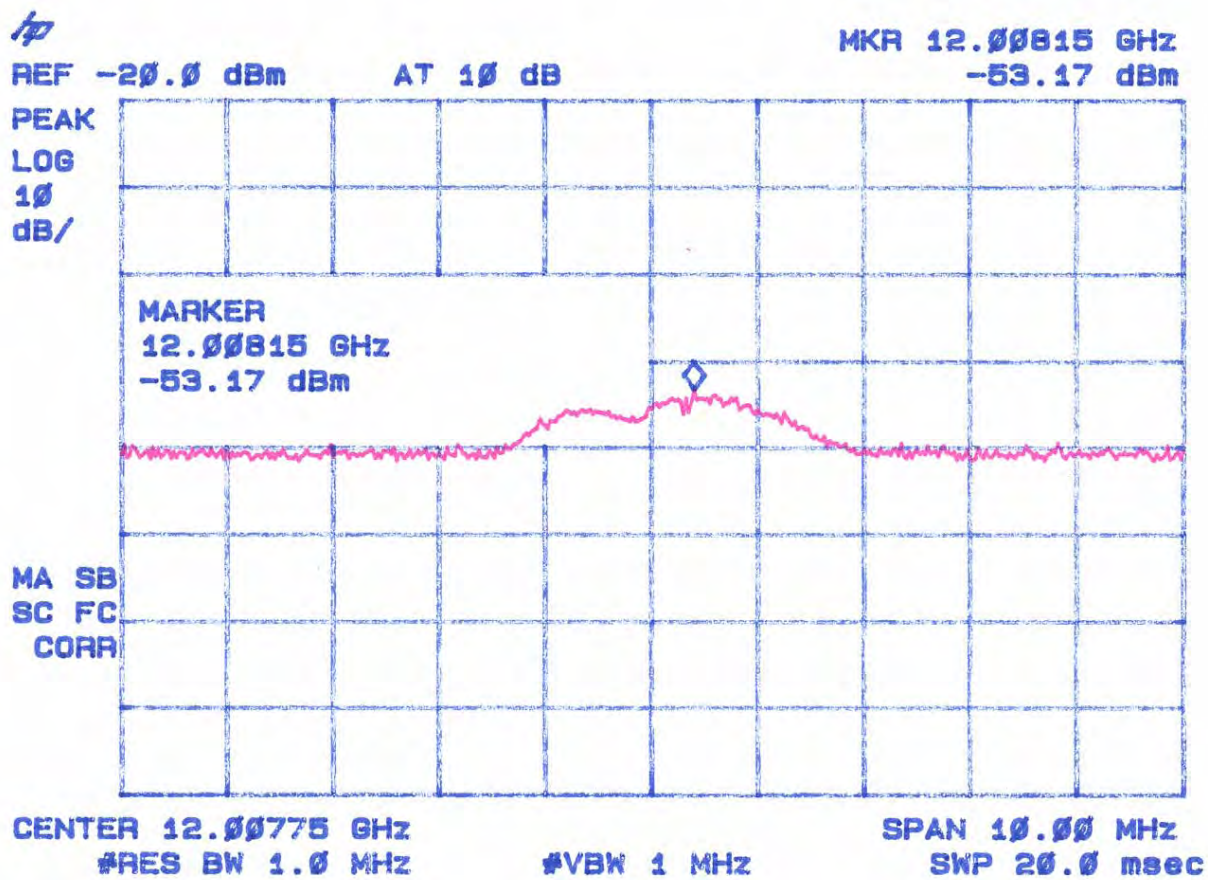

Table 4b. PEAK RADIATED SPURIOUS EMISSIONS (Mid)

Radiated Spurious Emissions										
Test By:	Test:	Spurious Emissions- -Mid Channel				Client:	Cirronet			
GR	Project:	07-0087		Class:	B	Model:	WIT2410T			
Frequency	Test Data	AF	Test Data	AF+CA-AMP	Results	Limits	Distance /	Margin	PK	
(MHz)	(dBm)	Table	(dBuV)	(dB)	(uV/m)	(uV/m)	Polarity	(dB)	/ QP	
2435.863	-18.2	1hn3mv	88.9	31.9	1094186.8		3m./VERT		PK	
4871.838	-58.5	1hn3mv	48.5	5.3	491.9	5000.0	3m./VERT	20.1	PK	
7307.188	-45.6	1hn3mv	61.4	9.8	3650.1	5000.0	3m./VERT	2.7	PK	
9742.412	-50.4	1hn3mv	56.6	13.1	3038.1	109418.7	3m./VERT	31.1	PK	
12178.78	-60.3	1hn3mv	46.8	17.6	1645.1	5000.0	3m./VERT	9.7	PK	

Data corrected by 0.1 dB for loss of high pass filter, except to fundamental

** Conversion from 1 meter to 3 meters = -9.54 dB

SAMPLE CALCULATION:

RESULTS (uV/m @ 3m) = Antilog ((-58.5 + 5.3 + 107)/20) = 491.9

CONVERSION FROM dBm TO dBuV = 107 dB

Tester

Signature: 

Name: Gersop Riera

Figure 4b - 1
Peak Radiated Spurious Emission 15.247(c) Fundamental Mid

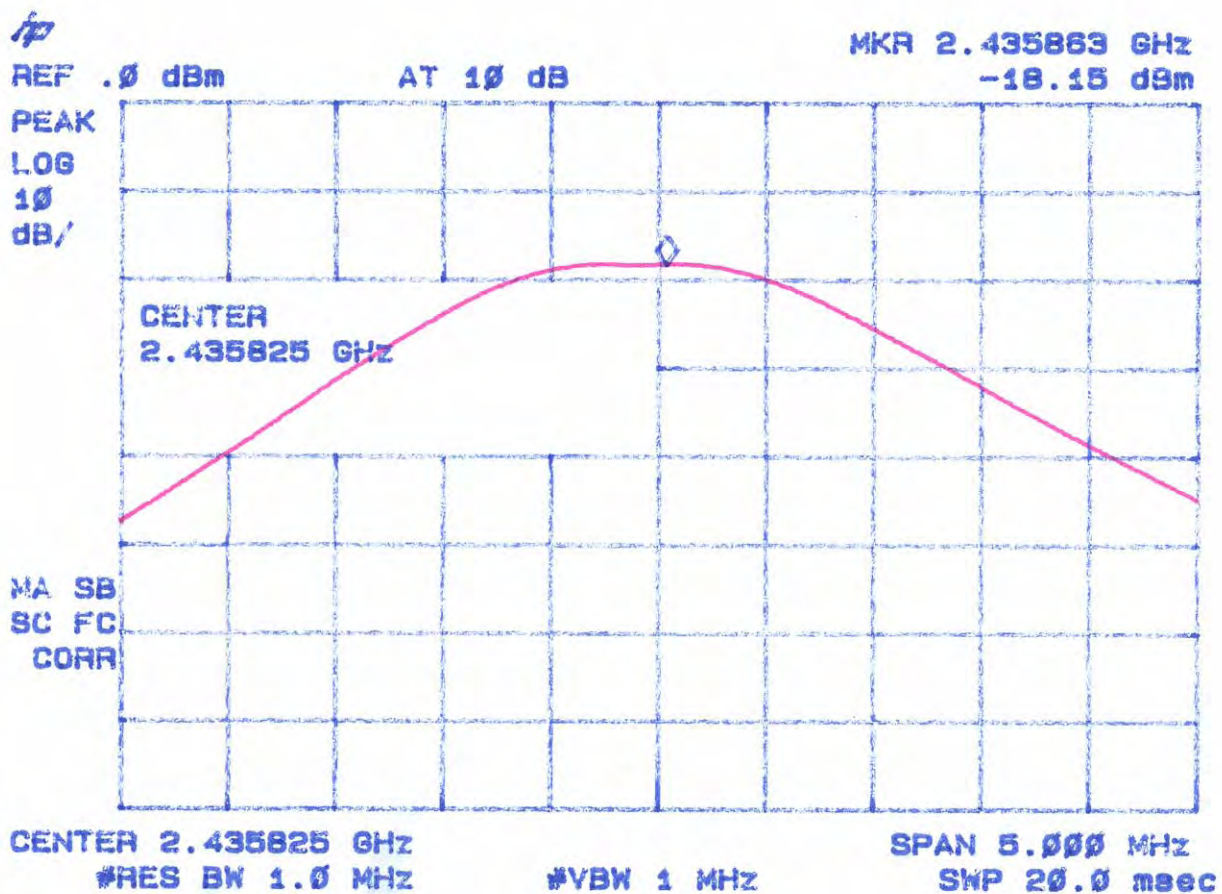

Figure 4b - 2
Peak Radiated Spurious Emission 15.247(c) Mid

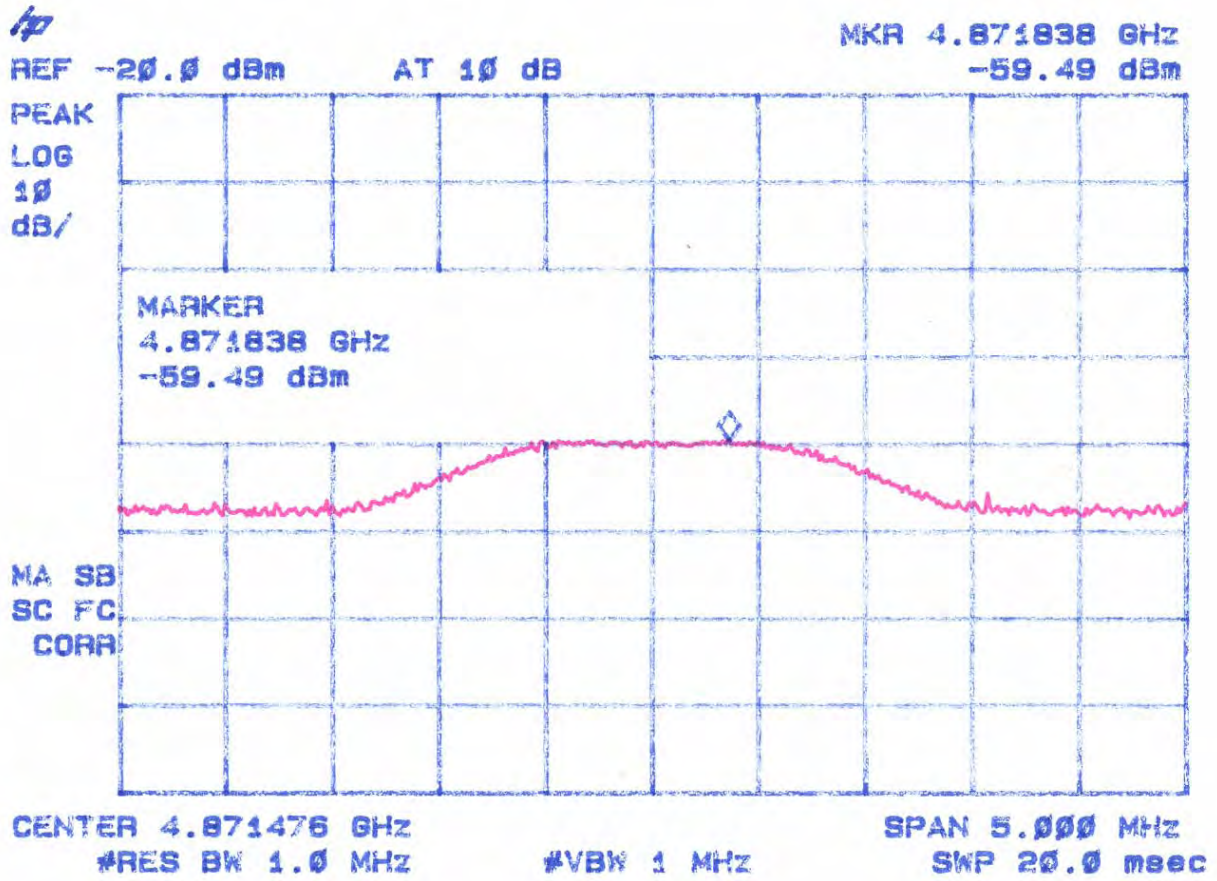

Figure 4b - 3
Peak Radiated Spurious Emission 15.247(c) Mid

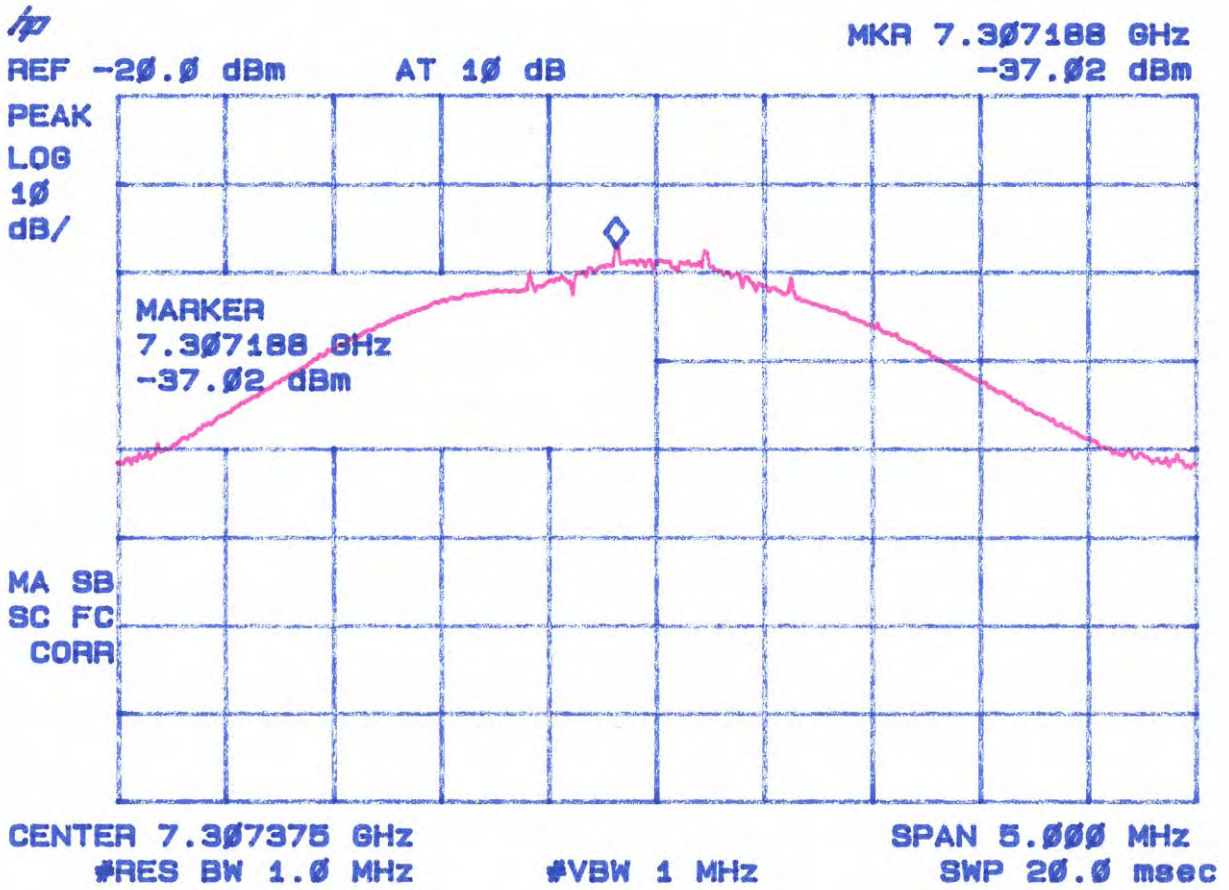

Figure 4b - 4
Peak Radiated Spurious Emission 15.247(c) Mid

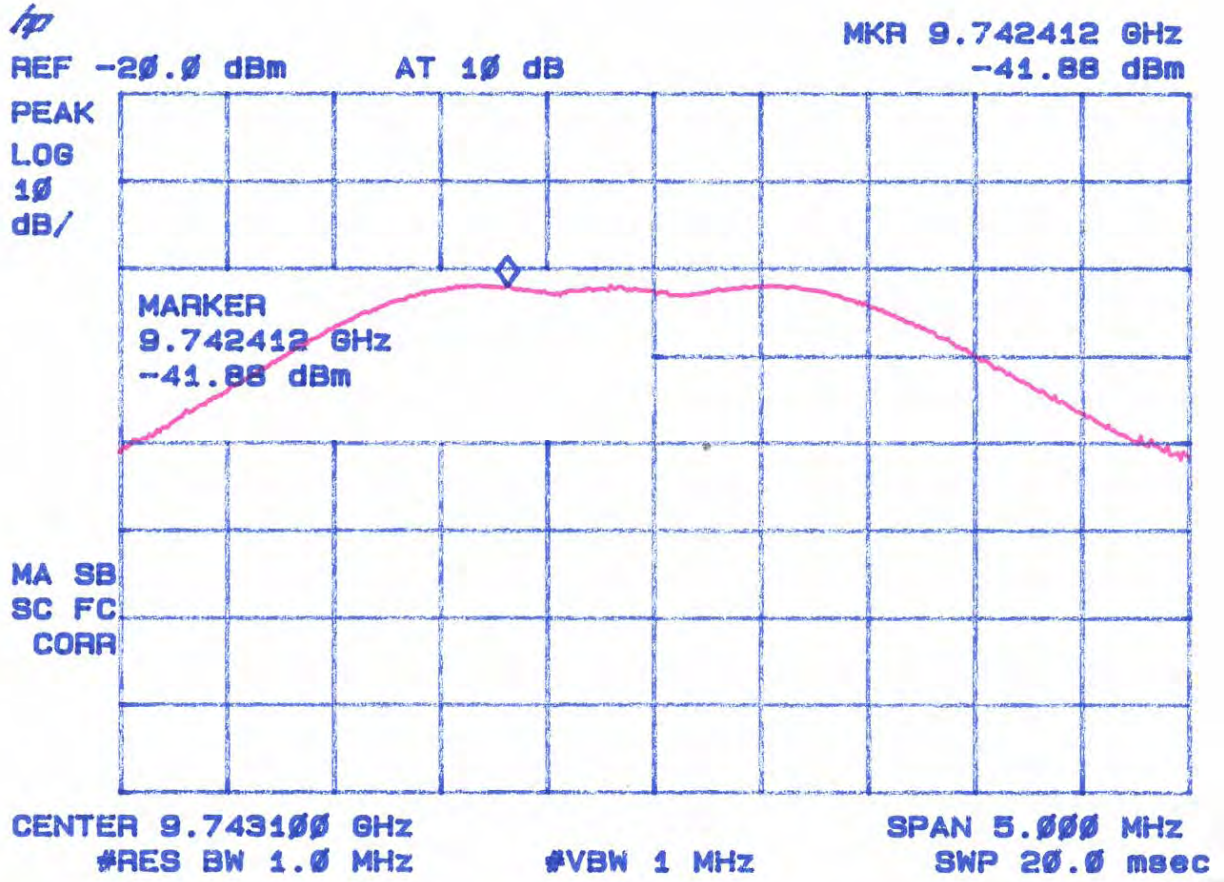

Figure 4b – 5
Peak Radiated Spurious Emission 15.247(c) Mid

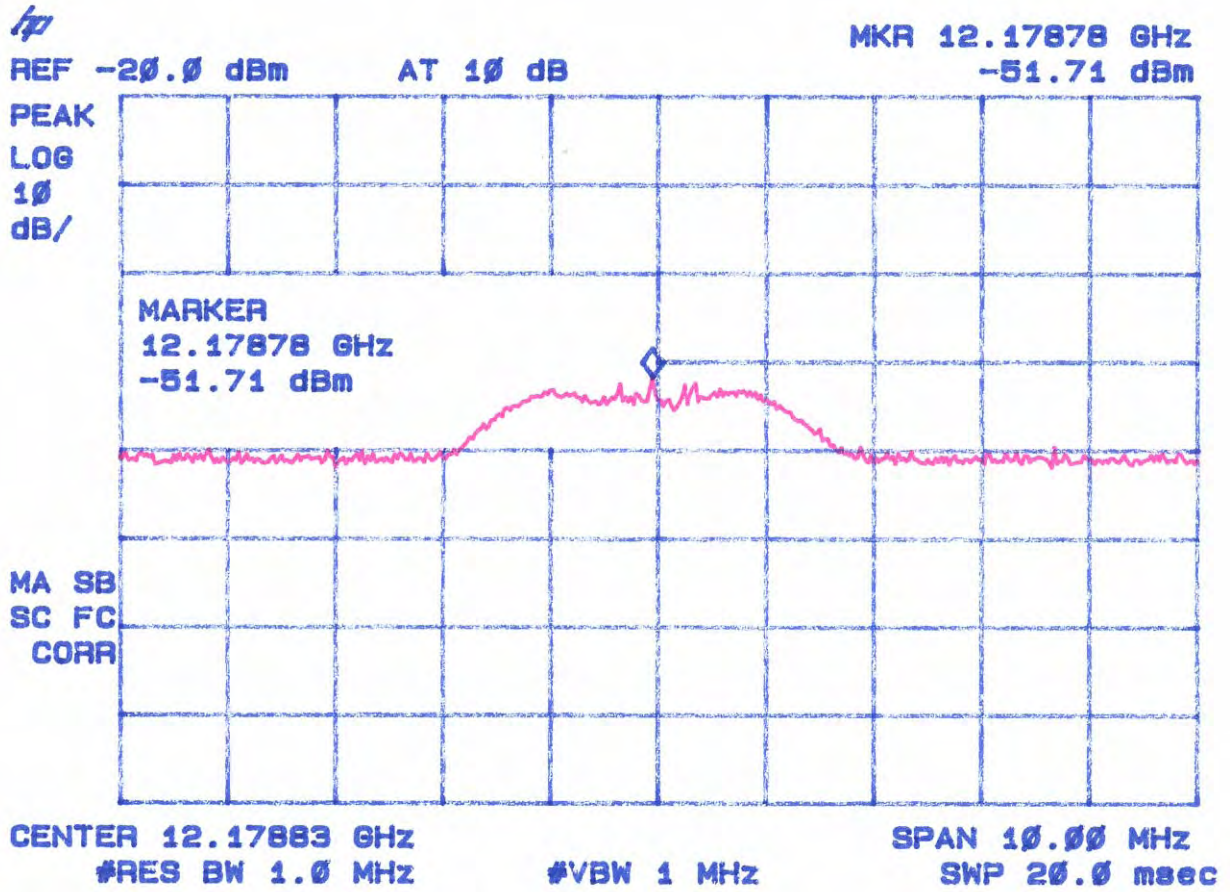

Table 4c. PEAK RADIATED SPURIOUS EMISSIONS (High)

Radiated Spurious Emissions										
Test By:	Test:	Spurious Emissions- High Channel				Client:	Cirronet			
GR	Project:	07-0087		Class:	B	Model:	WIT2410T			
Frequency	Test Data	AF	Test Data	AF+CA-AMP	Results	Limits	Distance/	Margin	PK	
(MHz)	(dBm)	Table	(dBuV)	(dB)	(uV/m)	(uV/m)	Polarity	(dB)	/ QP	
2470.06	-18.1	1HN3mV	88.9	32.0	1106374.3		3m./VERT		PK	
4939.31	-59.4	1HN3mv	47.6	5.6	453.5	5000.0	3m./VERT	20.8	PK	
7409.888	-44.8	1HN3mV	62.2	10.1	4139.5	5000.0	3m./VERT	1.6	PK	
9878.837	-53.9	1HN3mV	53.1	13.3	2085.2	11067.4	3m./VERT	14.5	PK	
12350.25	-62.4	1HN3mV	44.6	17.9	1329.1	5000.0	3m./VERT	11.5	PK	

Data corrected by 0.1 dB for loss of high pass filter, except to fundamental

** Conversion from 1 meter to 3 meters = -9.54 dB

SAMPLE CALCULATION:

RESULTS (uV/m @ 3m) = Antilog ((-59.4 + 5.6 + 107)/20) = 453.5

CONVERSION FROM dBm TO dBuV = 107 dB

Tester

Signature: _____



Name: Gersop Riera

Figure 4c – 1
Peak Radiated Spurious Emission 15.247(c) Fundamental High

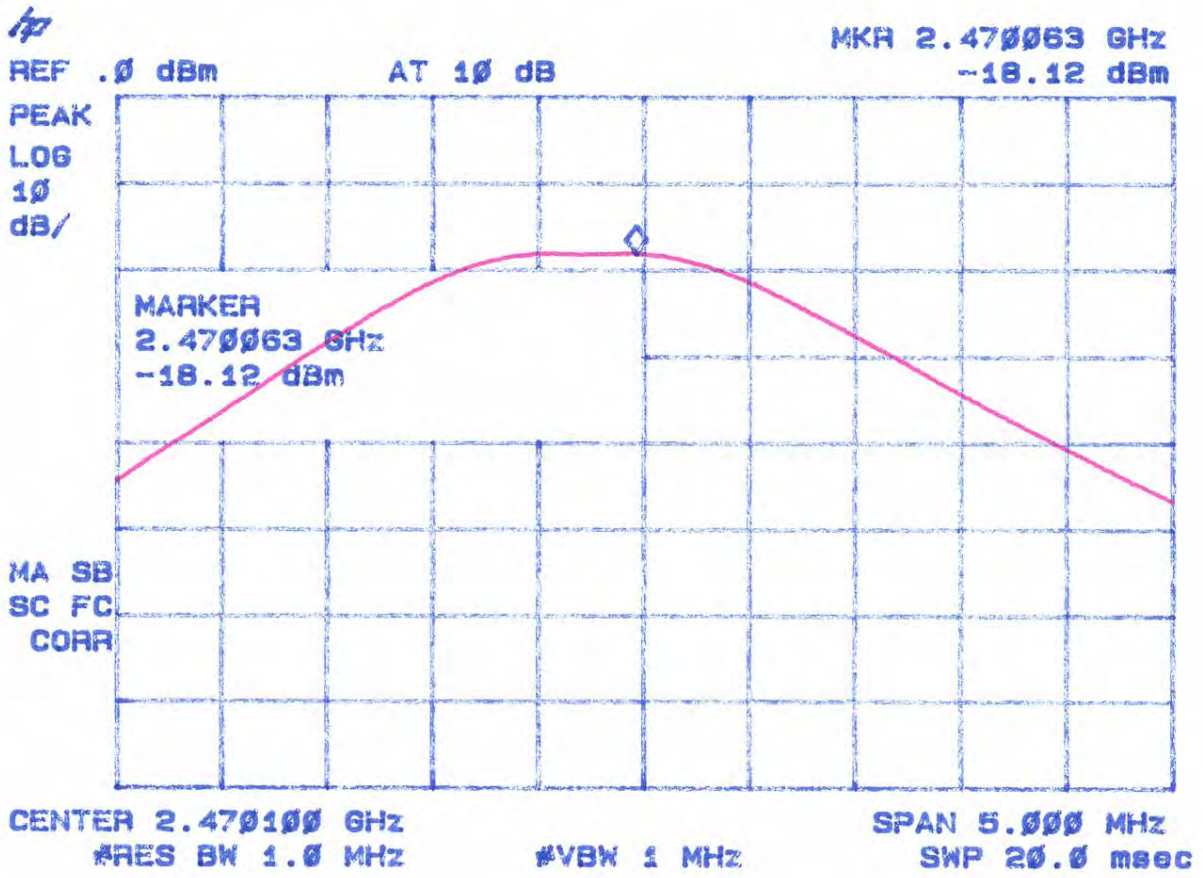

Figure 4c – 2
Peak Radiated Spurious Emission 15.247(c) High

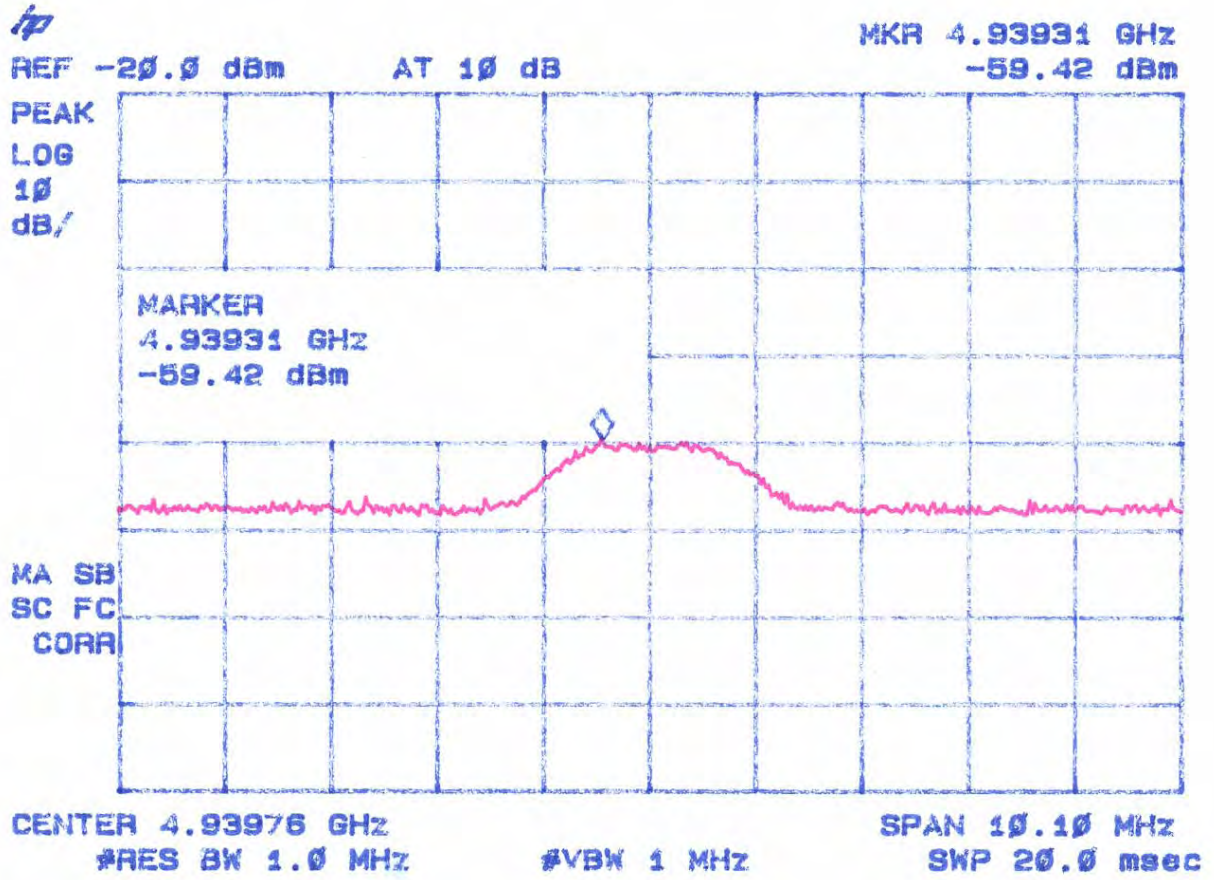

Figure 4c – 3
Peak Radiated Spurious Emission 15.247(c) High

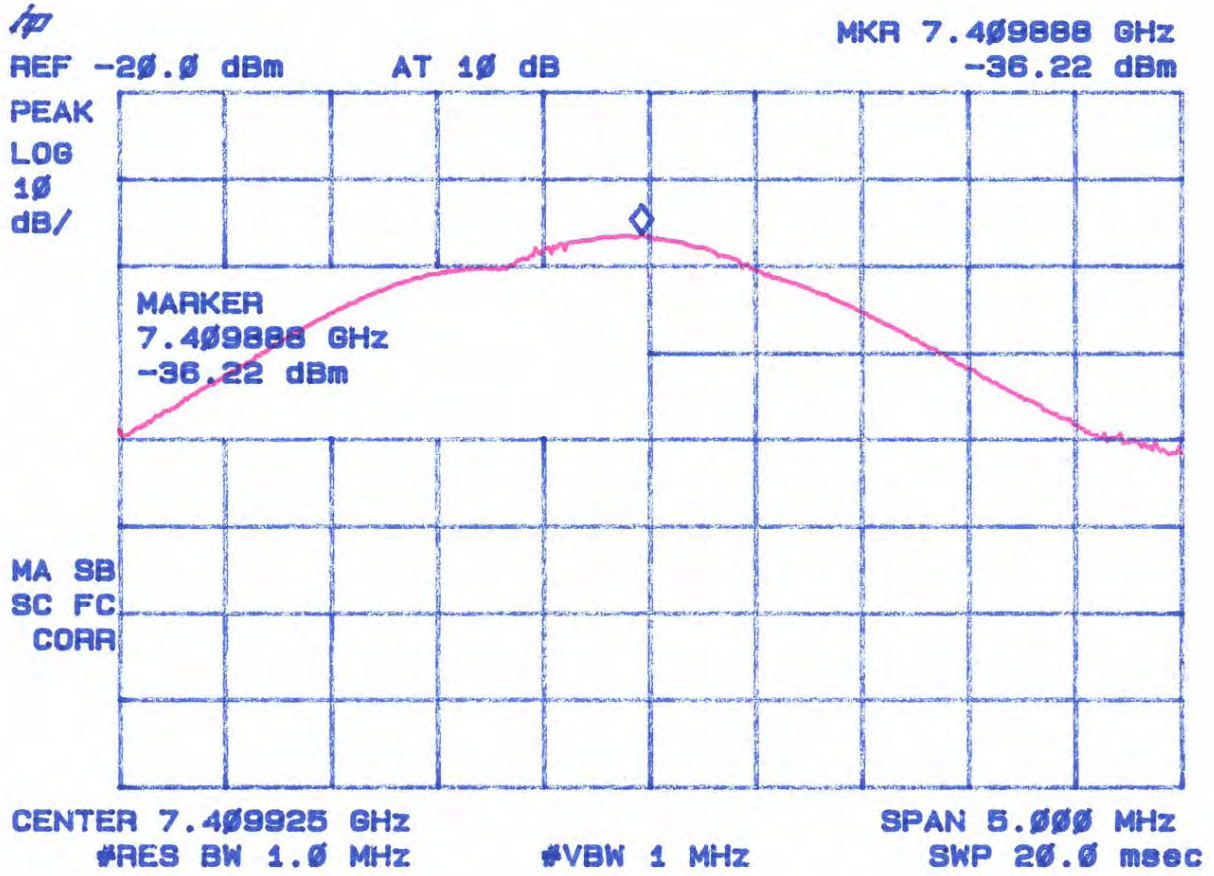

Figure 4c – 4
Peak Radiated Spurious Emission 15.247(c) High

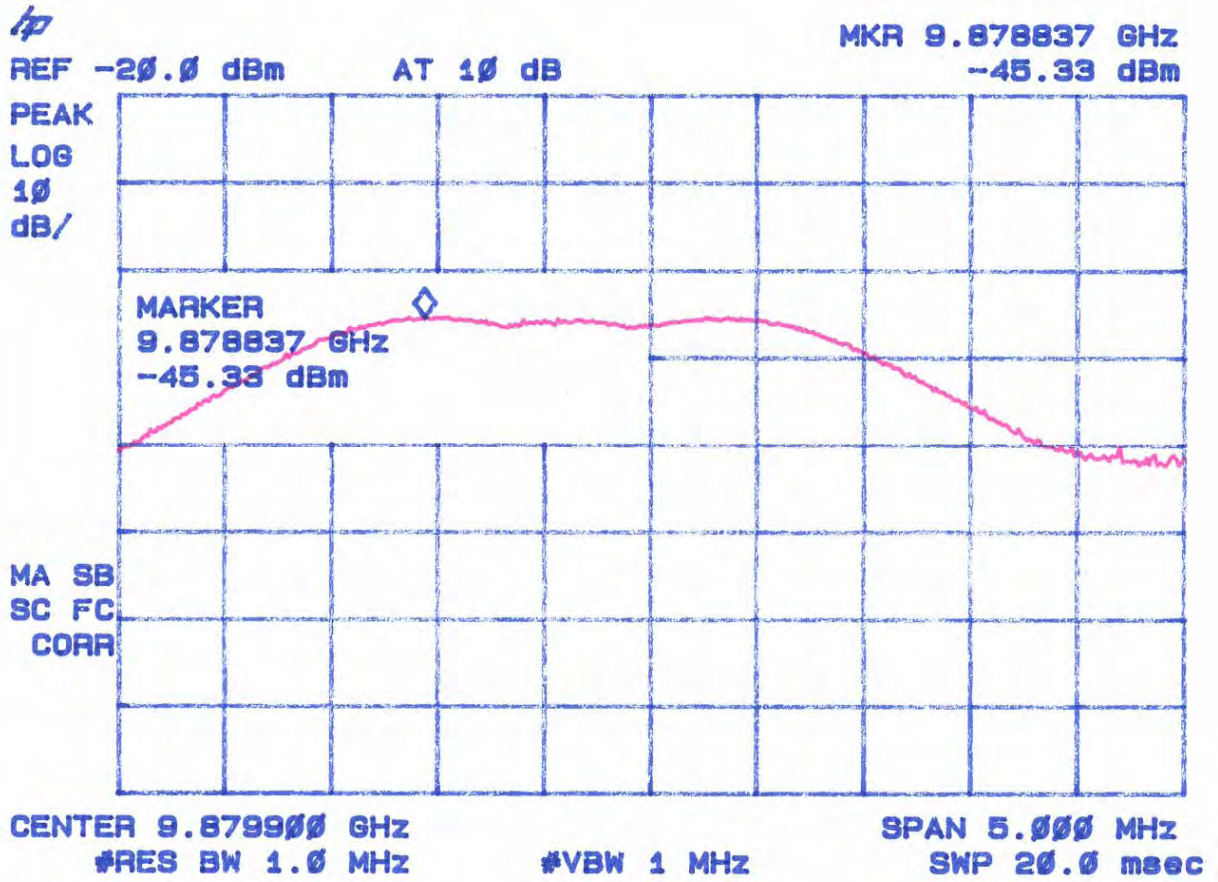
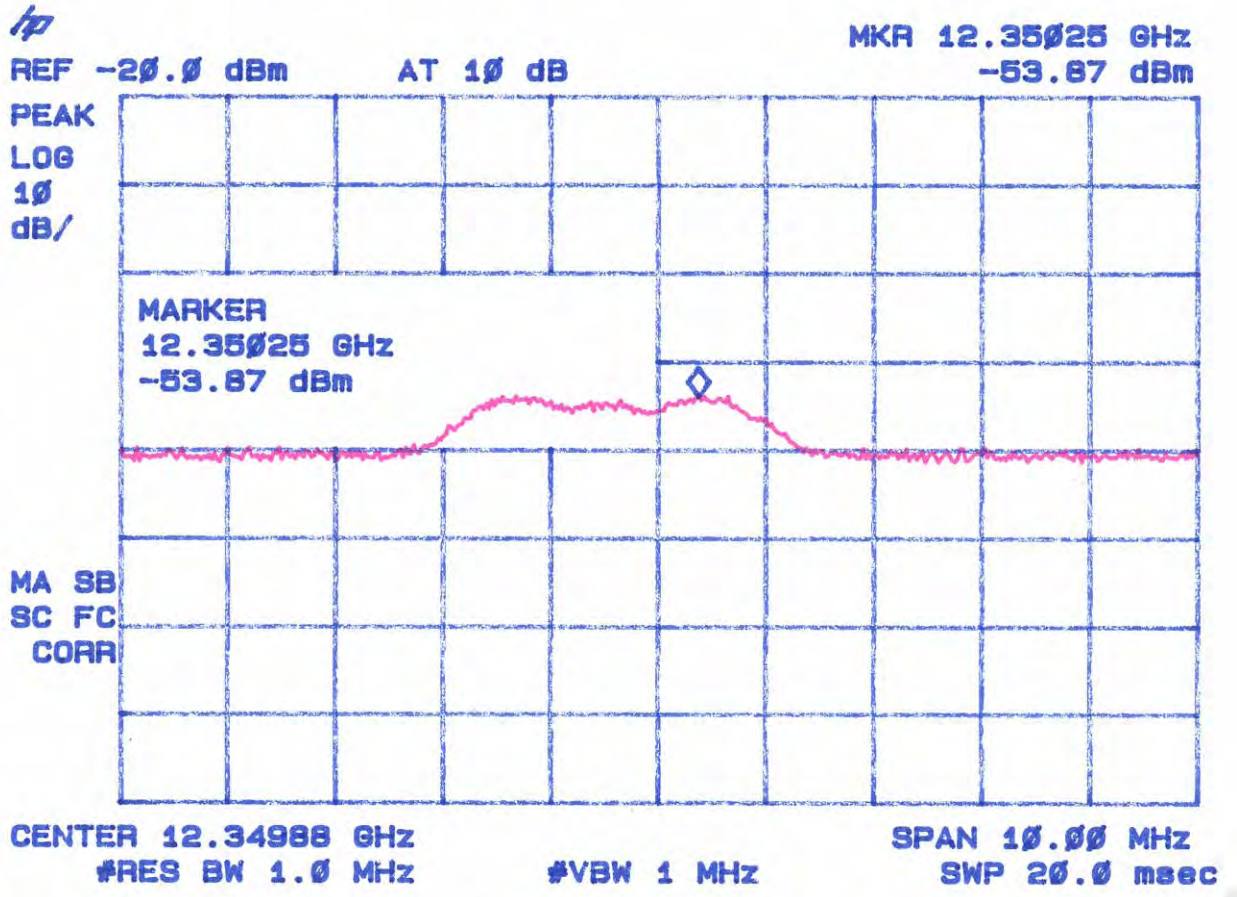

Figure 4c – 5
Peak Radiated Spurious Emission 15.247(c) High



2.9 Average Spurious Emission in the Frequency Range 30 - 25000 MHz (FCC Section 15.247(c))

The results of average radiated spurious emissions falling within restricted bands are given in Tables 5a – 5u.

Worst Case Transmit Duty Cycle for WIT2410T

The duty cycle de-rating factor used in the calculation of average radiated limits (per 15.209) is described below. This factor was calculated by first determining the worst case scenario for system operation – worst case being defined as the scenario when the WIT2410T would be transmitting the longest period during a dwell.

The worst case operating scenario is as follows:

- 1) point to point operation
(only two units communicating with each other)
- 2) data flow is almost completely unidirectional
(that is, one radio is relaying a large amount of data to the other radio with only synchronization data being passed back the other direction)
- 3) The amount of data being fed to the radio is exactly proportioned out to fit the maximum packet size allowable (280 bytes). The radio cannot send more than 280 bytes on a single channel – additional data must be sent on the next hop.

For this example, a remote unit is transferring a large data file to a base unit.

Maximum transmit time by Remote on a single channel:

$$= 280 \text{ bytes} * 8 \text{ bits /byte} * (1/460.8\text{kbps}) = 4.86 \text{ ms}$$

The minimum hop duration for this scenario would be 6.94ms. Given that we have 86 channels in our hop set, it takes 597ms to go through the entire hop table and repeat a transmission on the same channel. Therefore, only 4.86 ms worth of data can be transmitted on a single channel in any 100ms time period.

The transmission duty cycle correction factor is then calculated as:

$$20 \log_{10} (4.86\text{ms}/100\text{ms}) = \mathbf{-26.3 \text{ dB}}$$

Table 5a. AVERAGE RADIATED SPURIOUS EMISSIONS Low Channel

Radiated Spurious Emissions									
Test By:	Test:	Spurious Emissions- Low Channel			Client:	Cirronet			
GR	Project:	07-0087		Class:	Average	Model:	WIT2410T		
Frequency	Test Data	AF	Test Data	AF+CA-AMP	Results	Limits	Distance/	Margin	PK
(MHz)	(dBm)	Table	(dBuV)	(dB)	(uV/m)	(uV/m)	Polarity	(dB)	/ QP
2401.83	-43.7	1HN3mV	63.3	31.9	57517.1		3m./VERT		PK
4803.063	-83.8	1hn3mv	23.2	5.1	25.9	500.0	3m./VERT	25.7	PK
7204.813	-71.5	1hn3mv	35.5	9.5	177.3	5751.7	3m./VERT	30.2	PK
9606.912	-78.9	1hn3mv	28.1	12.9	112.0	5751.7	3m./VERT	34.2	PK
12008.15	-89.0	1hn3mv	18.0	17.3	57.9	500.0	3m./VERT	18.7	PK

Data corrected by 0.1 dB for loss of high pass filter, except to fundamental

** Conversion from 1 meter to 3 meters = -9.54 dB

SAMPLE CALCULATION:RESULTS (uV/m @ 3m) = Antilog ((-83.8 + 5.1 + 107)/20) = 25.9
 CONVERSION FROM dBm TO dBuV = 107 dB

Tester
Signature: _____



Name: Gersop Riera

Table 5b. AVERAGE RADIATED SPURIOUS EMISSIONS Mid Channel

Radiated Spurious Emissions										
Test By:	Test:	Spurious Emissions- Mid Channel				Client:	Cirronet			
GR	Project:	07-0087		Class:	Average	Model:	WIT2410T			
Frequency	Test Data	AF	Test Data	AF+CA-AMP	Results	Limits	Distance/	Margin	PK	
(MHz)	(dBm)	Table	(dBuV)	(dB)	(uV/m)	(uV/m)	Polarity	(dB)	/ QP	
2435.863	-44.5	1hn3mv	62.6	31.9	52977.5		3m./VERT		PK	
4871.838	-84.8	1hn3mv	22.2	5.3	23.8	500.0	3m./VERT	26.4	PK	
7307.188	-71.9	1hn3mv	35.1	9.8	176.7	500.0	3m./VERT	9.0	PK	
9742.412	-76.7	1hn3mv	30.3	13.1	147.1	5297.8	3m./VERT	31.1	PK	
12178.78	-86.6	1hn3mv	20.5	17.6	79.7	500.0	3m./VERT	16.0	PK	

Data corrected by 0.1 dB for loss of high pass filter, except to fundamental

** Conversion from 1 meter to 3 meters = -9.54 dB

SAMPLE CALCULATION:RESULTS (uV/m @ 3m) = Antilog ((-84.8 + 5.3 + 107)/20) = 23.8
 CONVERSION FROM dBm TO dBuV = 107 dB

Tester
 Signature: 

Name: Gersop Riera

Table 5c. AVERAGE RADIATED SPURIOUS EMISSIONS High Channel

Radiated Spurious Emissions									
Test By:	Test:	Spurious Emissions- High Channel				Client:	Cirronet		
GR	Project:	07-0087		Class:	Average	Model:	WIT2410T		
Frequency	Test Data	AF	Test Data	AF+CA-AMP	Results	Limits	Distance/	Margin	PK
(MHz)	(dBm)	Table	(dBuV)	(dB)	(uV/m)	(uV/m)	Polarity	(dB)	/ QP
2470.06	-44.4	1HN3mV	62.6	32.0	53567.6		3m./VERT		PK
4939.31	-85.7	1hn3mv	21.3	5.6	22.0	500.0	3m./VERT	27.1	PK
7409.888	-71.1	1HN3mV	35.9	10.1	200.4	500.0	3m./VERT	7.9	PK
9878.837	-80.2	1HN3mV	26.8	13.3	101.0	5356.8	3m./VERT	34.5	PK
12350.25	-88.7	1HN3mV	18.3	17.9	64.3	500.0	3m./VERT	17.8	PK

Data corrected by 0.1 dB for loss of high pass filter, except to fundamental

** Conversion from 1 meter to 3 meters = -9.54 dB

SAMPLE CALCULATION:RESULTS (uV/m @ 3m) = Antilog ((-85.7 + 5.6 + 107)/20) = 22.0
 CONVERSION FROM dBm TO dBuV = 107 dB

Tester
 Signature: 

Name: Gersop Riera

2.10 Band Edge Measurements

Band Edge measurements were made at a Low Channel and High Channel peak at highest EUT related emission outside the occupied bandwidth. A peak measurement was made of the fundamental, and the emission was measured using a peak setting. A Resolution Bandwidth of $> 1\%$ of the emission bandwidth was used. This procedure was repeated for the high channel.

The plots shown were verified using a Horn Antenna. No preamp was used.

The limits were derived as follows:

High Bandedge

$$5000 \text{ uV/m} = -33.02 \text{ dBm}$$

$$-33.02 \text{ dBm} - 32.0 \text{ dB (antenna factor and cable loss)} = -65.02 \text{ dBm limit}$$

Fundamental measured at High Channel from Table 4c: -18.1 dBm

Delta from conducted measurement of band edge from fundamental peak to highest spur 10 MHz outside band edge: -55.11

$$-18.1 - 55.11 = -73.21$$

Low Bandedge

$$-33.02 \text{ dBm} - 31.09 \text{ dB (antenna factor and cable loss)} = -64.92 \text{ dBm limit}$$

Fundamental measured at Low Channel from Table 4a: -17.4 dBm

Delta from conducted measurement of band edge from fundamental peak to highest spur 10 MHz outside band edge: -56.59

$$-17.4 - 56.59 = -73.99$$

Figure 6a. Band Edge Compliance
Antenna Conducted, High Channel

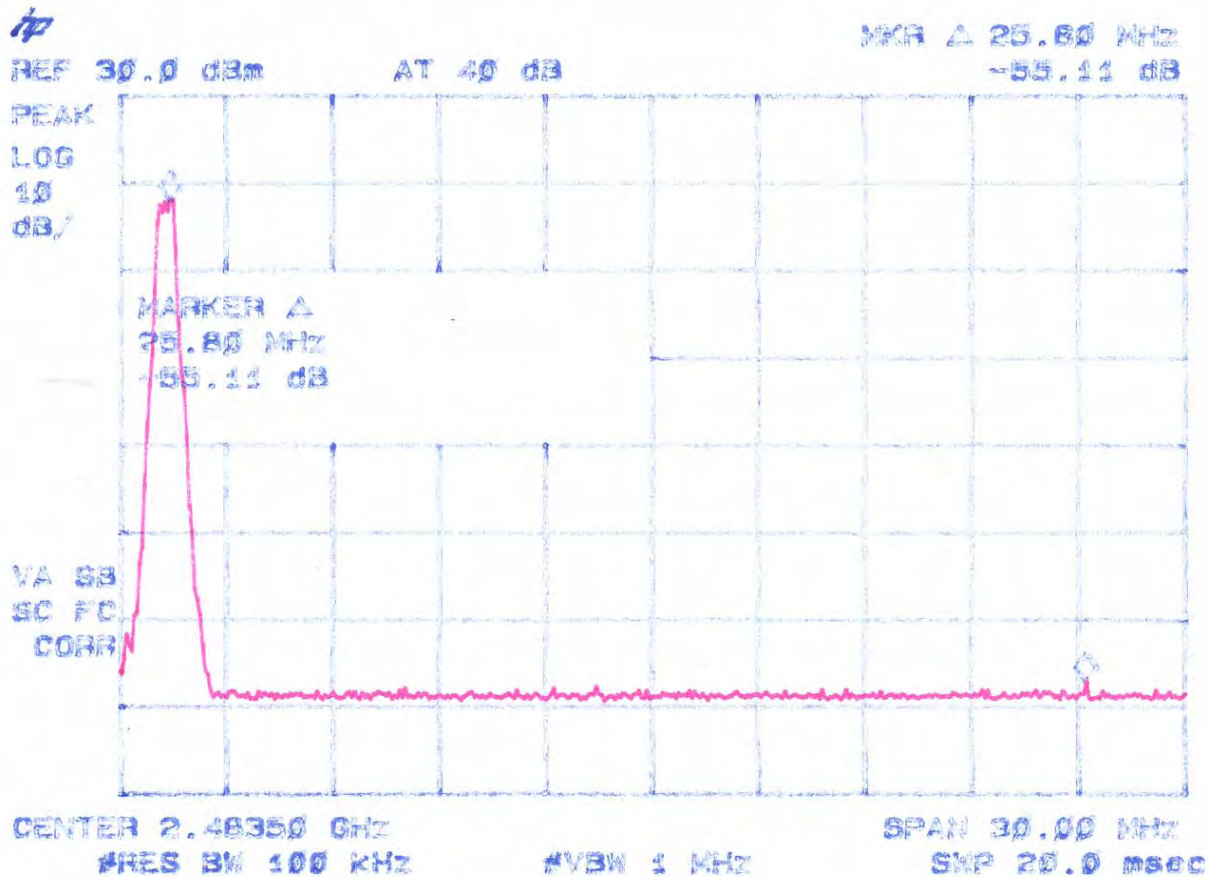

Figure 6b. Band Edge Compliance
Antenna Conducted, Low Channel

