

ADI Confidential

Vital Signs Monitoring (VSM) Watch

FEATURES

Vital signs monitoring platform
Wearable battery powered platform
Real-time live data view
Data storage to flash memory for offline analyses
Easy configuration

DEVICES HOSTED IN THE VSM WATCH

nRF52840
ADP5360
ADXL362
ADPD4100
AD8233
5940
AD7156

EVALUATION KIT CONTENTS

The VSM Watch
A Charging Cradle
A USB Type A to micro-USB cable
Firmware Debug Board

SOFTWARE NEEDED

VSM WaveTool

GENERAL DESCRIPTION

The vital sign monitoring (VSM) watch, EVAL-HCRWATCH4Z, is a modular development, demonstration, and data collection platform for high performance vital signs monitoring applications based on Analog Devices, Inc., analog front ends and sensors.

It is a wearable, battery-powered device which enables the continuous monitoring and on-demand spot check measurement of photoplethysmography (PPG), electrodermal activity (EDA, bioimpedance-based), skin temperature, electrocardiography (ECG, biopotential based), and motion/activity (based on a 3-axis accelerometer).

It allows for synchronized, multiparameter data storage on internal memory for later data retrieval and offline analysis and/or live monitoring on a PC (Windows® OS) or Android or iOS-based device.

PREPARING THE VSM WATCH

Before using the VSM watch, proper preparations must be made. Ensure the battery of the watch is charged and the WaveTool program for PC is successfully installed. See the Powering Up the System for the First Time sections for installation instructions. The watch firmware must be upgraded using the VSM WaveTool.

CONDITIONS REGARDING THE USE OF THIS PRODUCT IN HEALTHCARE APPLICATIONS

This device design is being provided as-is without any express or implied representations or warranties of any kind and the use of this device shall impose no legal obligation on Analog Devices, Inc., and its subsidiaries, employees, directors, officers, servants, and agents. In addition, it is understood and agreed to that the device is not authorized for use in safety critical healthcare applications (such as life support) in which malfunction or failure of a product can be expected to result in personal injury or death. This device must not be used for diagnostic purposes. It must not be used with a defibrillator or other equipment that produces high voltages in excess of the supply rails on the evaluation board.

This device is provided for evaluation and development purposes only. It is not intended for use as, or as part of, an end product. Any use of the device in such applications is at your own risk and you shall fully indemnify Analog Devices, its subsidiaries, employees, directors, officers, servants and agents for all liability and expenses arising from such unauthorized usage. You are solely responsible for compliance with all legal and regulatory requirements connected to such use.

TABLE OF CONTENTS

Features.....	1	Software Tools.....	10
Devices Hosted in the VSM Watch	1	Vital Signs Monitored	11
Evaluation Kit Contents	1	Photoplethysmography (PPG)—ADPD4100	11
Software Needed.....	1	Motion and Activity - ADXL362.....	11
General Description.....	1	Electrocardiography - AD8233.....	11
Preparing the VSM Watch	1	Bio-Impedance – AD5940.....	11
Conditions Regarding the Use of This Product in Healthcare Applications	1	Skin and Ambient Temperature	12
Revision History	2	Use Cases.....	13
Evaluation Platform Overview	3	Embedded Algorithms for Evaluation	16
Evaluation Platform.....	7	Pedometer.....	16
Overview	7	Automatic Gain Control	16
Powering Up the System for the First Time	7	Battery Life and Memory Footprint.....	17
Water Resistance.....	7	Battery Life	17
Bluetooth USB PC Dongle (nRF52840)	7	Memory Footprint.....	17
Buttons.....	8	Ordering Information	17
Display Indicators.....	9	Device Models	19

REVISION HISTORY

8/2020—Revision 0: Initial Version

EVALUATION PLATFORM OVERVIEW



Figure 1. Overview VSM Watch Platform **ADD BETTER PICTURE WITH LABELS**

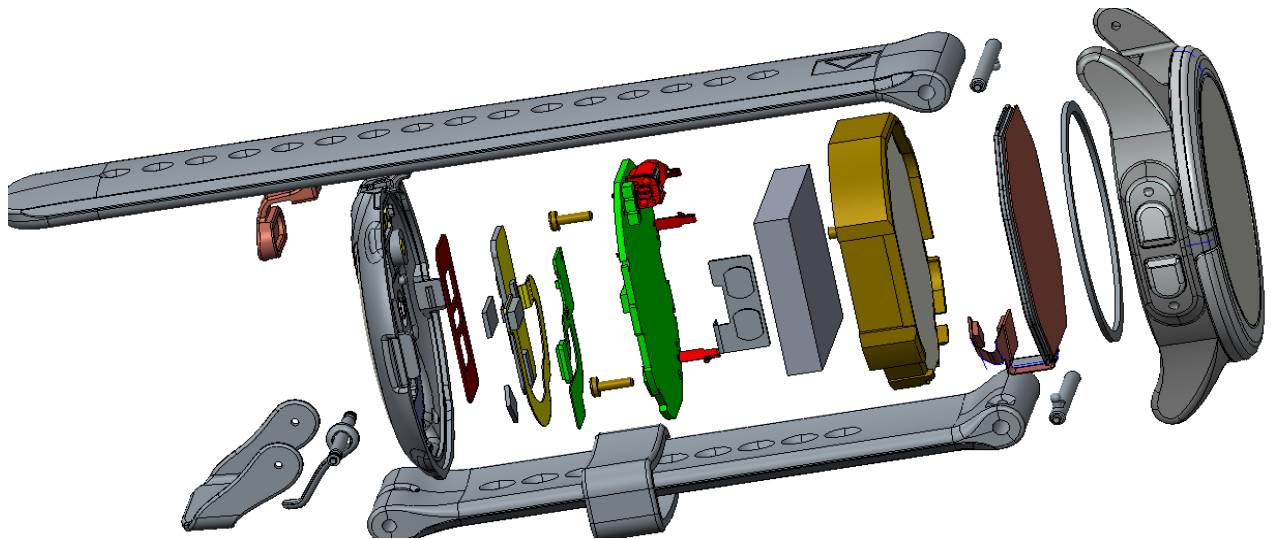

Figure 2. VSM Watch Expanded View



Figure 3. Connections and Buttons – Top (We can clean and update these pictures as well)



Figure 4. Connections and Buttons – Bottom

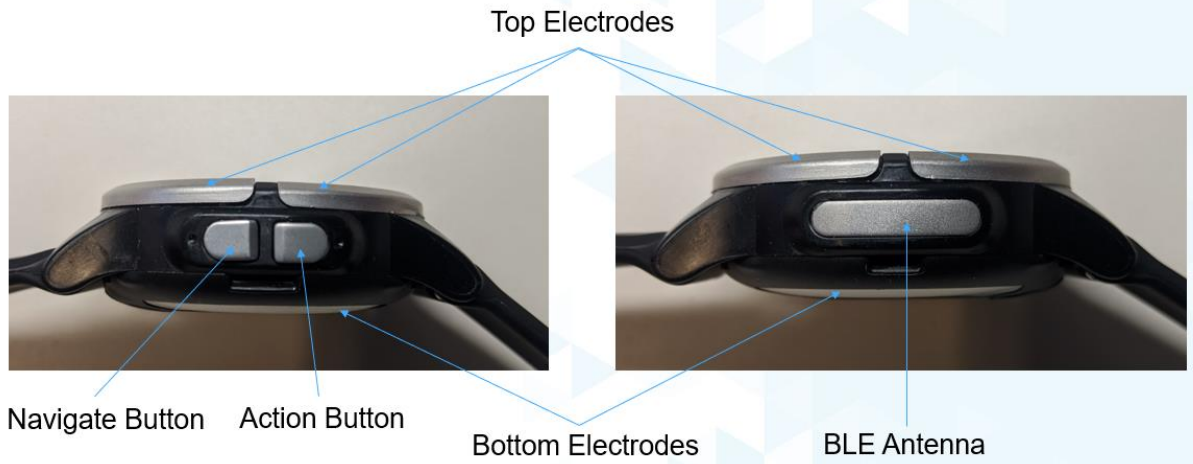

Figure 5. Connections and Buttons - Sides

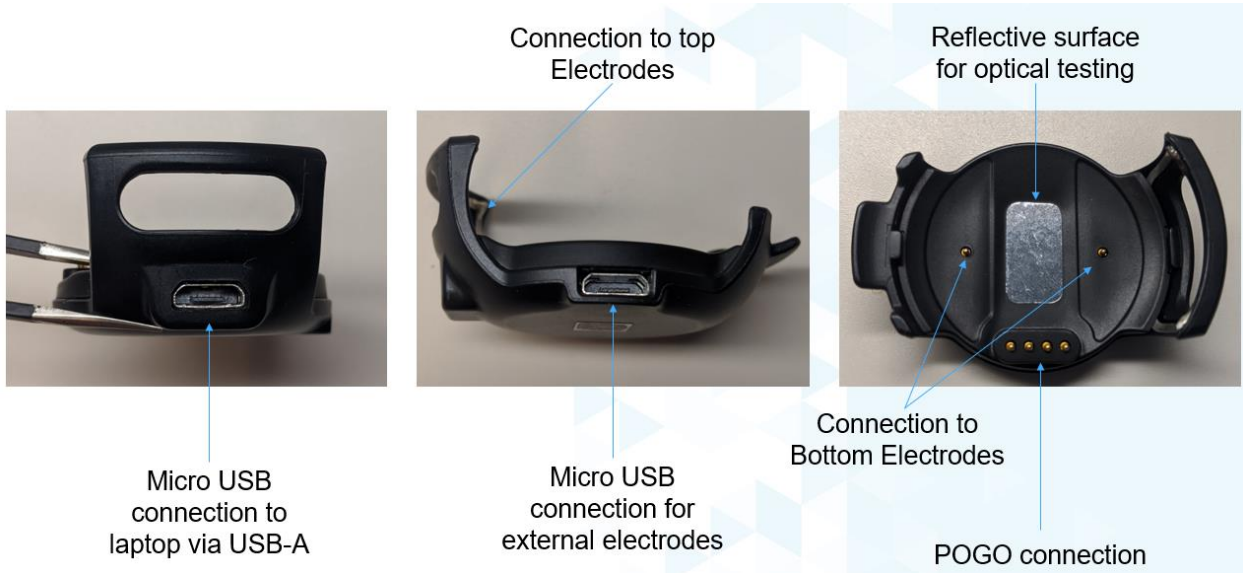

Figure 6. Charging Cradle

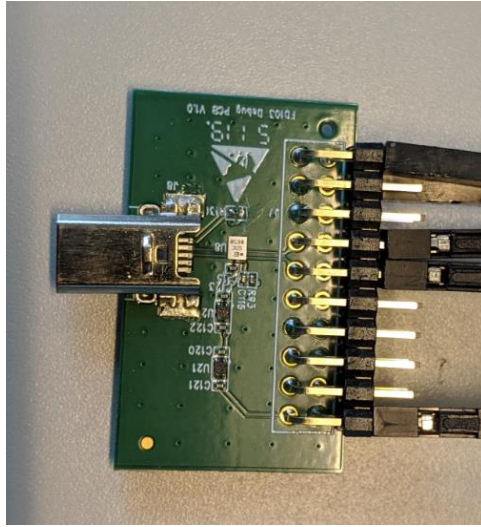

Figure 7: Firmware Debug Board

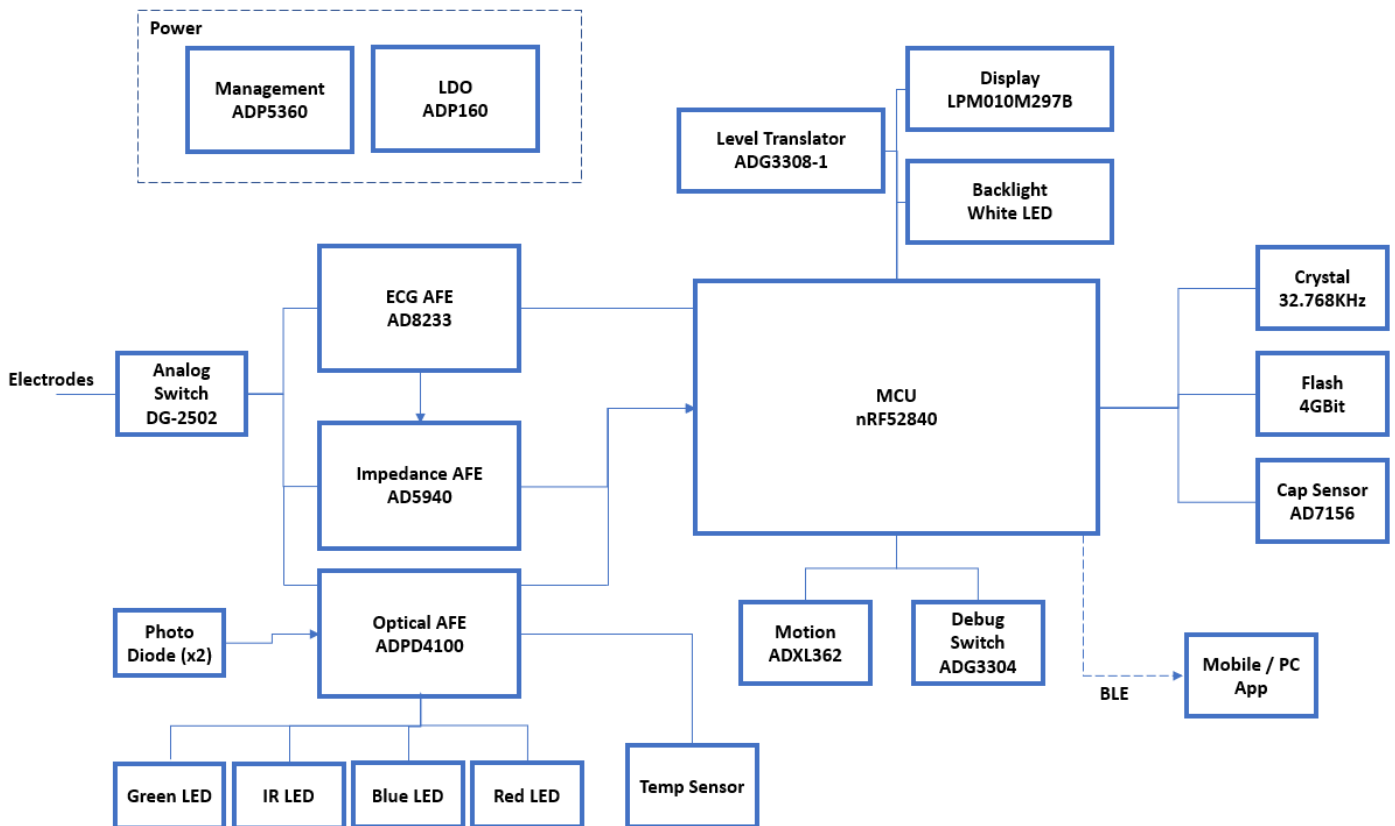

Figure 8: Simplified Electrical Block Diagram

EVALUATION PLATFORM

OVERVIEW

The VSM watch is a modular development, demonstration, and data collection platform for high performance vital signs monitoring applications based on Analog Devices analog front ends and sensors.

The platform optimized electrical and mechanical design hosts all the required circuits to sense, condition, digitize, process, store, and wirelessly transmit real-time, vital sign related data. This platform does the following:

- Minimizes the risks associated with a new electronic design
- Minimizes the time to market for a new final product
- Facilitates the evaluation of a wide range of Analog Devices solutions in a single battery-powered wearable ecosystem
- Highlights and addresses the challenges associated with a wearable device
- Allows the developer to focus on other added value tasks such as algorithm development and the overall firmware for engineering and scientific research and validation

This platform is not intended to do the following:

- Act as the final product for a specific application
- Demonstrate an application specific optimized design. Trade-offs have been made to allow platform flexibility

The evaluation platform kit contains the following items:

- The VSM platform (the watch)
- Charging Cradle
- A USB Type A to micro-usb cable
- Firmware Debug Board



Figure 9. Box Contents

The USB cable is used for the following purposes:

1. Recharge the battery via the charging cradle (connecting the watch to a PC or wall adaptor)
2. Upgrade the platform firmware (using the software tools provided and as explained in the **Error! Reference source not found.** section)
3. Download data stored in the internal flash memory for offline data analyses or other purposes

Only use the watch with the USB cable provided.

POWERING UP THE SYSTEM FOR THE FIRST TIME

The VSM Watch is shipped from the factory in an ultra-low-power shipment mode. To exit this power mode, place the watch into the cradle with connected USB cable providing power.

Before using the watch for the first time, fully charge the battery by connecting the VSM watch to a PC or wall adaptor using the USB cable provided. A firmware upgrade may be required. Details can be found in the **Error! Reference source not found.** section.

WATER RESISTANCE

The watch is IP68 rated. Despite this rating, please exercise caution if showering, swimming or doing any other activity with the VSM Watch that exposes it directly to moisture.

BLUETOOTH USB PC DONGLE (nRF52840)

The VSM Watch platform leverages an off-the-shelf Nordic BLE dongle for communicating wirelessly with a PC. The nRF52840 is available for purchase separately through multiple online vendors. Custom FW for this dongle can be found at <https://www.nordicsemi.com/Software-and-tools/Development-Kits/nRF52840-Dongle>

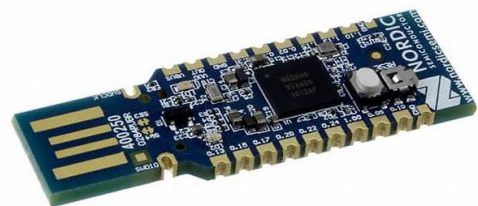

Figure 10. BLE USB PC Dongle (nRF52840)

BUTTONS

Two buttons are found on the side of the watch. An explanation of their uses is found in the tables below.

Table 1. Button Descriptions



Button		Description
Navigation		Press to proceed to the next screen
Select		Press for 'OK'

Table 2. Button Usage in Watch App

Button Combination	Button Actions	Button Press Timings (sec)
Select button Short press	select current page action	0.05
Navigate button Short press	navigate to next page	0.05
Select button Long press	back to previous page action	3
Navigate button Long press	call soft reset of watch app	3
Select + Navigate button Long press	enter Bootloader	3
Navigate button Long press when Watch is powered down	Watch wakes up	1

Table 3. Button Usage in Bootloader

Button Combination	Button Actions	Button Press Timings (sec)
Select button Short press	No action	-
Navigate button Short press	No action	-
Select button Long press	No action	-
Navigate button Long press	Enter Watch app	7
Select + Navigate button Long press	Enter Watch app	7
Select button Short press	No action	-

DISPLAY INDICATORS

Home Screen

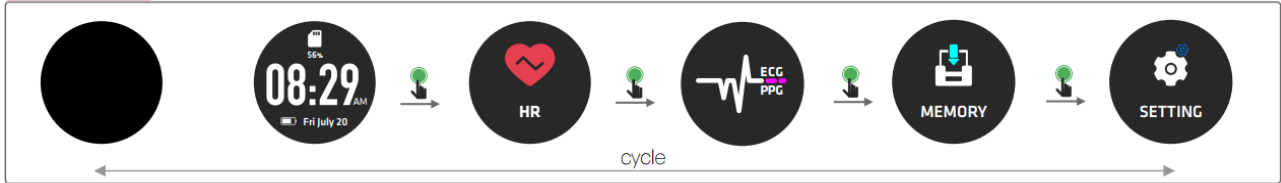

Setting

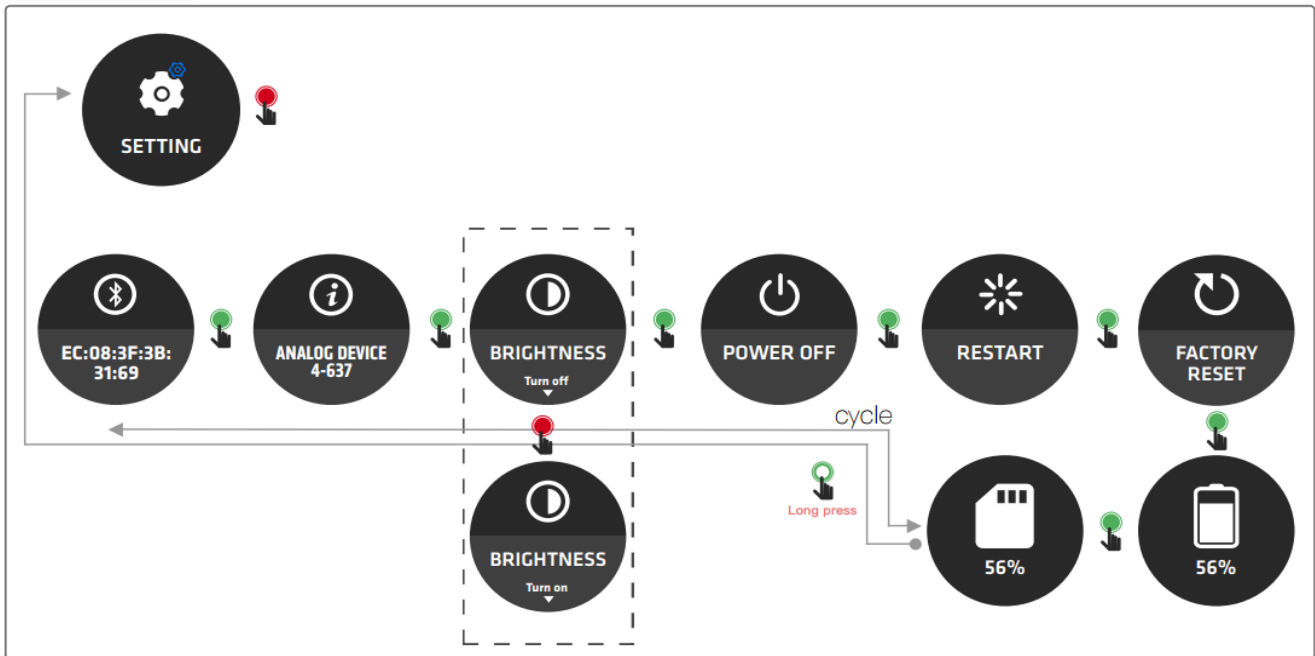

Power on



Restart



SOFTWARE TOOLS

For information on the VSM Watch Software, please refer to the VSM Watch Software User Guide.

VITAL SIGNS MONITORED

To minimize the power line interference (50 Hz/60 Hz) and improve the quality of the output signal, it is recommended to use the BLE link.

PHOTOPLETHYSMOGRAPHY (PPG)— ADPD4100

The ADPD4100 operates as a complete multimodal sensor front end, stimulating up to eight LEDs (four on the VSM Watch) and measuring the return signal on up to eight separate current inputs. Twelve time slots are available, enabling 12 separate measurements per sampling period.

The data output and functional configuration utilize an I2C interface on the ADPD4001 or a serial port interface (SPI) on the ADPD4000. The control circuitry includes flexible LED signaling and synchronous detection. The devices use a 1.8 V analog core and 1.8 V/3.3 V compatible digital input/output (I/O).

Refer to the ADPD4100 product page and data sheet for further details.

Details regarding the hardware implementation are found in Table 4 and Table 5.

Table 4. Electrical Connections to the ADPD4100 Inputs

Input Pin	Description
IN-1	VEMD8080 Photodiode 1
IN-2	VEMD8080 Photodiode 2
IN-3	Temp Sensor
IN-4	Temp Sensor
IN-5	ECG / Bio-Z
IN-6	ECG / Bio-Z
IN-7	ECG / Bio-Z
IN-8	ECG / Bio-Z

Table 5. Electrical Connections to the ADPD4100 LED Current Sinks

Current Sink	Color	Wavelength	No. of LEDs
LED1A	Green	530 nm	1
LED2A	Infrared	850 nm	1
LED3A	Red	660 nm	1
LED4A	Blue	470 nm	1

MOTION AND ACTIVITY - ADXL362

Motion is sensed by the [ADXL362](#), an ultra-low power, 3-axis, ± 2 g/ ± 4 g/ ± 8 g digital output high resolution (1 mg/LSB) accelerometer. Its power consumption is 1.8 μ A at 100 samples per second (SPS) and 3.0 μ A at 400 SPS, while its motion activated wake-up mode only requires 270 nA.

A pedometer algorithm is embedded for evaluation that can be enabled in Wavetool.

ELECTROCARDIOGRAPHY - AD8233

The [AD8233](#) is a 50 μ A 2.0 mm \times 1.7 mm WLCSP low noise single lead analog output biopotential front end.

Integrated ECG Electrodes

The [AD8233](#) is connected to the electrodes hosted in the top and bottom surfaces of the watch. The two electrodes on the top of the watch are connected to IN- pin and RLD pin, while the two electrodes on the bottom of the watch are shorted together (temporarily while this measurement is active) and connected to the IN+ input.

The quality of the contact of the bottom electrodes has a dramatic effect on the output waveform. Dry, hairy skin poses a challenge for this measurement until moisture accumulates between the skin and the electrodes. This usually happens a few minutes after the user puts on the device. Accumulated moisture decreases the contact impedance and, therefore, the quality of the output waveform improves.

The configuration of this signal chain is similar to an ambulatory ECG device (Holter monitor).

Table 6. Electrical Specifications of the ECG Signal Chain¹

Specification	Value (typ)	Unit
Passing Bandwidth	0.4 to 42	Hz
High-Pass Filter	First Order	N/A
Low-Pass Filter	Second order (quality factor = 0.671)	N/A
AD8233 Gain	151	V/V
ADC Resolution	16	bits
Noise RTI	TBD	μ V p-p
Sampling Rate	50 to 1000	SPS

¹ N/A means not applicable.

External ECG Cables

The charging cradle provides a secondary micro-USB connection to be used with external wired electrodes.

BIO-IMPEDANCE – AD5940

Impedance is measured using the AD5940 Impedance AFE. Proper electrical contact between these two electrodes and the skin is critical for accurate and reliable long-term measurement. Adequate tightness of the watch strap helps achieve a proper contact and wearing the watch beside (but not on top of) the ulnar styloid process (the protruding wrist bone) also helps ensure a reliable and high-quality measurement.

Note that these two electrodes are also used by the ECG measurement, which temporarily shorts them together.

Therefore, the impedance measurement is not valid while the ECG measurement is ongoing.

Table 7. Electrical Specifications of the AD5940

Specification	Value (Typ)	Unit
Conductivity Range	0.2 to 20	μS (3%)
Accuracy at 0.2 μS	3	%
Accuracy at 1 μS	0.8	%
Accuracy at 10 μS	0.1	%
Accuracy at 20 μS	3	%
Resolution at 1 μS	1	nS
Resolution at 10 μS	2	nS
Excitation Frequency	100	Hz
Sampling Rate	30	SPS

SKIN AND AMBIENT TEMPERATURE

The skin temperature measurement is based on a thermistor (NTCG104EF104FTDSX). The thermistor used in the skin temperature measurement is thermally coupled to the bottom of the watch. This thermistor is connected to one of the analog inputs of the ADPD4100 and its performance is heavily dependent on the mechanical connection that is made to the body.

Table 8. Electrical Specifications of the Signal Chain That Measures Skin Temperature

Specification	Value (Typ)
Temperature Range	-30°C to +50°C
Resolution at 25°C	TBD

USE CASES

Basic modes of operation have been designed for the VSM Watch that are selectable by supplied Device Configuration Files:

- High Performance PPG
- Synchronized PPG with EDA
- Synchronized PPG with ECG spot-check
- High Performance ECG spot-check
- Multi-wavelength PPG
- *Future Use Cases will continue to be developed*

These modes of operation are intended to demonstrate the different types of configurations that are possible with the VSM Watch but are not specific to an end-application. The high configurability of the VSM Watch allows for the possibility to program a configuration that cannot be supported by the existing hardware, software and firmware. Users can load these Use Cases as a known-good starting point to explore measurements of interest before modifying the platform for their specific purpose.

Please refer to the Software User Guide for details on how to evaluate and modify these Use Cases in Wavetool.

Table 9. Use Case Table

Use Case	PPG	Motion	Impedance	ECG	Temp.
Shipment Mode	Off	Off	Off	Off	Off
Hibernate	Off	Off	Off	Off	Off
PPG – High Performance (1 LED)	500 SPS	50 SPS			1 SPS
ECG – High Performance	50 SPS	50 SPS		1000 SPS	1 SPS
PPG + Impedance (1 LED)	100 SPS	50 SPS	30 SPS		1 SPS
PPG + ECG (1 LED)	100 SPS	50 SPS		250 SPS	1 SPS
PPG – All LEDs	100 SPS	50 SPS			1 SPS

All Use Cases are designed to allow for automatic logging to the onboard NAND Flash when the watch detects that it is being worn based on its capacitive sensor.

Default ADPD Configuration for each usecase:

Use Case	Sampling Rate	TIA Gain CH1/CH2	Pulse width	Slot/Wavelength	Number of Pulses
PPG – High Performance (1 LED)	500 SPS	50/50	2	F/530	64
ECG – High Performance	50 SPS	50/50	2	F/530	64
PPG + Impedance (1 LED)	100 SPS	50/50	2	F/530	64
PPG + ECG (1 LED)	100 SPS	50/50	2	F/530	64
PPG – All LEDs	100 SPS	50/50	2	F/530, G/, H/, I/	64

Default ADXL configuration for each usecase

Use Case	Sampling Rate	Measurement Range
PPG – High Performance (1 LED)	50 SPS	4g
ECG – High Performance	50 SPS	4g
PPG + Impedance (1 LED)	50 SPS	4g
PPG + ECG (1 LED)	50 SPS	4g
PPG – All LEDs	50 SPS	4g

Default AD5940 Configuration for each usecase:

Use Case	Sampling Rate	TIA Gain
PPG – High Performance (1 LED)	NA	
ECG – High Performance	1000 SPS	
PPG + Impedance (1 LED)	30 SPS	
PPG + ECG (1 LED)	250 SPS	
PPG – All LEDs	NA	

Default AD8233 Configuration for each usecase:

Use Case	AC/DC coupling	FR mode	Gain
PPG – High Performance (1 LED)	NA	NA	NA
ECG – High Performance	DC Coupling	On	150k
PPG + Impedance (1 LED)	NA	NA	NA
PPG + ECG (1 LED)	DC Coupling	On	150K
PPG – All LEDs	NA	NA	NA

EMBEDDED ALGORITHMS FOR EVALUATION

Basic algorithms are included with the VSM Watch to demonstrate this type of functionality. More advanced algorithms with specific device configurations are provided here.

PEDOMETER

A pedometer algorithm takes raw data from the 3-axis accelerometer and outputs the steps taken.

AUTOMATIC GAIN CONTROL

The digitized output of the ADPD4100 is fed to this algorithm to ensure that the LED current and AFE gain is configured appropriately to maximize the usefulness of the Optical Signal. The default target is 70% of the allowable range for each LED (independently determined). This Gain Control is *not* optimized to achieve an ideal performance versus power. Further improvements can be made based on the end application's requirements to achieve a better battery life

BATTERY LIFE AND MEMORY FOOTPRINT

BATTERY LIFE

The battery life is determined by the type and number of sensors enabled, the sampling rate configured and is also dependent on other configuration details such as the LED current in the photoplethysmography measurements.

Table 10. System Battery Life for Several Use Cases

Use Case	Memory	Live BLE	Battery Life (Hours)
Shipment Mode	No	No	30000+
Hibernate	No	No	1000+
PPG – High Performance	Yes	Yes	14
ECG – High Performance	Yes	Yes	40
PPG + Impedance	Yes	Yes	50
PPG + ECG	Yes	Yes	40
PPG – All LEDs	Yes	Yes	20

The VSM watch is powered by a rechargeable 200 mAh battery.

MEMORY FOOTPRINT

The watch hosts a 512 MB memory.

The actual capacity of the memory is determined by the type and number of sensors enabled and the sampling rate configured.

Table 11. Memory Capacity (in Hours) for Different Use Cases

Vital Signs	Memory Capacity (Hours)
PPG – High Performance	18
ECG – High Performance	22
PPG + Impedance	63
PPG + ECG	43
PPG – All LEDs	23

Note : All the default usecases are designed to maximize the performance. By modifying various parameters of the AFEs one can achieve longer battery life and memory usage. For instance in ADPD4100 the default gain in AGC algorithm is set to 25K so as to get best PPG performance with various skin tones. Setting the gain to 100k/200k and lowering current value will result in significant improvement in battery life.

FCC COMPLIANCE STATEMENT

This device complies with Part 15 of the FCC Rules. Operation is subject to the following two conditions:

- (1) this device may not cause harmful interference, and
- (2) this device must accept any interference received, including interference that may cause undesired operation.

Changes or modifications not expressly approved by the party responsible for compliance could void the user's authority to operate the equipment.

This equipment has been tested and found to comply with the limits for a Class B digital device, pursuant to Part 15 of the FCC Rules. These limits are designed to provide reasonable protection against harmful interference in a residential installation. This equipment generates, uses and can radiate radio frequency energy and, if not installed and used in accordance with the instructions, may cause harmful interference to radio communications. However, there is no guarantee that interference will not occur in a particular installation.

If this equipment does cause harmful interference to radio or television reception, which can be determined by turning the equipment off and on, the user is encouraged to try to correct the interference by one or more of the following measures:

- Reorient or relocate the receiving antenna.
- Increase the separation between the equipment and receiver.
- Connect the equipment into an outlet on a circuit different from that to which the receiver is connected.
- Consult the dealer or an experienced radio/TV technician for help.

CAUTION

- Risk of explosion if the battery is replaced by and incorrect type.
- Disposal of a battery into fire or a hot oven, or mechanically crushing or cutting of a battery, that can result in an explosion;
- Leaving a battery in an extremely high temperature surrounding environment that can result in an explosion or the leakage of flammable liquid or gas;
- A battery subjected to extremely low air pressure that may result in an explosion or the leakage of flammable liquid or gas.

ORDERING INFORMATION

DEVICE MODELS

Table 12. Device Models

Model	Description
EVAL-HCRWATCH4Z	VSM Watch. Multiple VSMs (wearable battery-powered wireless system)



ESD Caution

ESD (electrostatic discharge) sensitive device. Charged devices and circuit boards can discharge without detection. Although this product features patented or proprietary protection circuitry, damage may occur on devices subjected to high energy ESD. Therefore, proper ESD precautions should be taken to avoid performance degradation or loss of functionality.

Legal Terms and Conditions

By using the evaluation board discussed herein (together with any tools, components documentation or support materials, the "Evaluation Board"), you are agreeing to be bound by the terms and conditions set forth below ("Agreement") unless you have purchased the Evaluation Board, in which case the Analog Devices Standard Terms and Conditions of Sale shall govern. Do not use the Evaluation Board until you have read and agreed to the Agreement. Your use of the Evaluation Board shall signify your acceptance of the Agreement. This Agreement is made by and between you ("Customer") and Analog Devices, Inc. ("ADI"), with its principal place of business at One Technology Way, Norwood, MA 02062, USA. Subject to the terms and conditions of the Agreement, ADI hereby grants to Customer a free, limited, personal, temporary, non-exclusive, non-sublicensable, non-transferable license to use the Evaluation Board FOR EVALUATION PURPOSES ONLY. Customer understands and agrees that the Evaluation Board is provided for the sole and exclusive purpose referenced above, and agrees not to use the Evaluation Board for any other purpose. Furthermore, the license granted is expressly made subject to the following additional limitations: Customer shall not (i) rent, lease, display, sell, transfer, assign, sublicense, or distribute the Evaluation Board; and (ii) permit any Third Party to access the Evaluation Board. As used herein, the term "Third Party" includes any entity other than ADI, Customer, their employees, affiliates and in-house consultants. The Evaluation Board is NOT sold to Customer; all rights not expressly granted herein, including ownership of the Evaluation Board, are reserved by ADI. CONFIDENTIALITY. This Agreement and the Evaluation Board shall all be considered the confidential and proprietary information of ADI. Customer may not disclose or transfer any portion of the Evaluation Board to any other party for any reason. Upon discontinuation of use of the Evaluation Board or termination of this Agreement, Customer agrees to promptly return the Evaluation Board to ADI. ADDITIONAL RESTRICTIONS. Customer may not disassemble, decompile or reverse engineer chips on the Evaluation Board. Customer shall inform ADI of any occurred damages or any modifications or alterations it makes to the Evaluation Board, including but not limited to soldering or any other activity that affects the material content of the Evaluation Board. Modifications to the Evaluation Board must comply with applicable law, including but not limited to the RoHS Directive. TERMINATION. ADI may terminate this Agreement at any time upon giving written notice to Customer. Customer agrees to return to ADI the Evaluation Board at that time. LIMITATION OF LIABILITY. THE EVALUATION BOARD PROVIDED HEREUNDER IS PROVIDED "AS IS" AND ADI MAKES NO WARRANTIES OR REPRESENTATIONS OF ANY KIND WITH RESPECT TO IT. ADI SPECIFICALLY DISCLAIMS ANY REPRESENTATIONS, ENDORSEMENTS, GUARANTEES, OR WARRANTIES, EXPRESS OR IMPLIED, RELATED TO THE EVALUATION BOARD INCLUDING, BUT NOT LIMITED TO, THE IMPLIED WARRANTY OF MERCHANTABILITY, TITLE, FITNESS FOR A PARTICULAR PURPOSE OR NON-INFRINGEMENT OF INTELLECTUAL PROPERTY RIGHTS. IN NO EVENT WILL ADI AND ITS LICENSORS BE LIABLE FOR ANY INCIDENTAL, SPECIAL, INDIRECT, OR CONSEQUENTIAL DAMAGES RESULTING FROM CUSTOMER'S POSSESSION OR USE OF THE EVALUATION BOARD, INCLUDING BUT NOT LIMITED TO LOST PROFITS, DELAY COSTS, LABOR COSTS OR LOSS OF GOODWILL. ADI'S TOTAL LIABILITY FROM ANY AND ALL CAUSES SHALL BE LIMITED TO THE AMOUNT OF ONE HUNDRED US DOLLARS (\$100.00). EXPORT. Customer agrees that it will not directly or indirectly export the Evaluation Board to another country, and that it will comply with all applicable United States federal laws and regulations relating to exports. GOVERNING LAW. This Agreement shall be governed by and construed in accordance with the substantive laws of the Commonwealth of Massachusetts (excluding conflict of law rules). Any legal action regarding this Agreement will be heard in the state or federal courts having jurisdiction in Suffolk

County, Massachusetts, and Customer hereby submits to the personal jurisdiction and venue of such courts. The United Nations Convention on Contracts for the International Sale of Goods shall not apply to this Agreement and is expressly disclaimed.

©2018 Analog Devices, Inc. All rights reserved. Trademarks and registered trademarks are the property of their respective owners.

UG16392-0-4/18(Sp0)



www.analog.com