

FCC Test Report

E.U.T. : **Wireless Optical Mouse**
Trade Name : **Agiler**
Model : **SAXM105A1, SAXM026A1, SAXM037A1 ,
SAXM106A1**
FCC ID : **HQXSAXM105A1**
Report No. : **RF-J19-0412-197**
Date of Report : **December 24, 2004**

Prepared for

Sysgration Ltd.

10F1.,No.868-3,Chung Cheng Rd.,Chung Ho,Taipei (235),Taiwan,R.O.C

Prepared by



Central Research Technology Co.

EMC Test Laboratory

No.11, Lane41, Fushuen St., Jungshan Chiu, Taipei, Taiwan, 104, R.O.C.



NVLAP LAB CODE 200575-0



0905
ILAC MRA

This report shall not be reproduced, except in full, without the written approval of Central Research Technology Co.. It may be duplicated completely in its entirety for legal use with the permission of the applicant. It should not be used to claim product endorsement by CNLA, NVLAP or any U.S. government agency. The test result in the report applies only to the sample tested.

Total : 20 Pages

Certification of Compliance

E.U.T. : Wireless Optical Mouse
Trade Name : Agiler
Model : SAXM105A1, SAXM026A1, SAXM037A1 ,SAXM106A1
FCC ID : HQXSAXM105A1
Manufacturer : Shanghai Sysgration Industrial Co.Ltd
Applicant : Sysgration Ltd.
Address :10F1.,No.868-3,Chung Cheng Rd.,Chung Ho,Taipei
(235),Taiwan,R.O.C
Arrival of Sample(s) : December 22, 2004
Date of Test : December 23, 2004
Applicable Standards : 47 CFR part 15, Subpart C
Deviation : N/A
Condition of Test Sample : Prototype



We, **Central Research Technology Co.**, hereby certify that one sample of the designated product was tested in our facility during the period mentioned above. The test records, data evaluation and Equipment Under Test (EUT) configurations shown in the present report are true and accurate representation of the measurements of the sample's RF characteristics under the conditions herein specified.

The test results show that the EUT as described in the present report is in compliance with the requirements set forth in the standards mentioned above and apply to the tested sample identified in the present report only. The test report shall not be reproduced, except in its entirety, without the written approval of Central Research Technology Co.

PREPARED BY : Cathy Chen , **DATE** : Dec. 24, 2004
(Cathy Chen/RF Engineer)
CHECKED BY : Sam Chien , **DATE** : Dec. 24, 2004
(Sam Chien/Technical Manager)
APPROVED BY : J. Y. Shih , **DATE** : Dec. 24, 2004
(Tsun-Yu Shih/Laboratory Head)

Contents

1	General Description.....	4
1.1	GENERAL DESCRIPTION OF EUT.....	4
1.2	CHARACTERISTIC OF E.U.T.....	4
1.3	TEST METHODOLOGY	4
1.4	REQUIREMENT FOR COMPLIANCE.....	5
1.5	THE SUPPORT UNITS.....	7
1.6	LAYOUT OF SETUP	8
1.7	TEST FACILITY	9
1.8	MEASUREMENT UNCERTAINTY	9
2	Field Strength of fundamental	10
2.1	APPLIED STANDARD	10
2.2	MEASUREMENT PROCEDURE	10
2.3	TEST CONFIGURATION	11
2.4	TEST INSTRUMENTS.....	12
2.5	TEST DATA	13
3	Radiated Emission.....	15
3.1	APPLIED STANDARD	15
3.2	MEASUREMENT PROCEDURE	16
3.3	TEST CONFIGURATION	17
3.4	TEST INSTRUMENTS.....	18
3.5	TEST DATA	19

Attachment 1 – Photographs of the Test Configurations

Attachment 2 – External Photographs of EUT

Attachment 3 – Internal Photographs of EUT

1 General Description

1.1 General Description of EUT

E.U.T.	: Wireless Optical Mouse
Model No.	: SAXM105A1, SAXM026A1, SAXM037A1, SAXM106A1
FCC ID	: HQXSAXM105A1
Brand	: Agiler
Power in	: DC 3V (Battery)
Test Voltage	: DC 3V (Battery)
Applicant	: Sysgration Ltd.
Manufacturer	: Shanghai Sysgration Industrial Co.Ltd

1.2 Characteristic of E.U.T.

Frequency Range : 27.045MHz

Function Modulation: FSK

The EUT is used to transmit control command only. Please refer to the user's manual for the details.

1.3 Test Methodology

For this E.U.T., the radiated emissions measurement performed according to the procedures illustrated in ANSI C63.4 and other required were illustrated in separate sections of this test report for detail.

1.4 Requirement for Compliance

(1) Field strength of Fundametal

According to 15.227(a),The field strength of any emission within this band shall not exceed 10,000 microvolts/meter at 3 meters. The emission limit in this paragraph is based on measurement instrumentation employing an average detector. The provisions in Section 15.35 for limiting peak emissions apply.

(2) Radiation emission

According to 15.227(b), The field strength of any emissions which appear outside of this band shall not exceed the general radiated emission limits in Section 15.209.

(3) Radiated emission limits, general requirements.

Except as provided elsewhere in this Subpart, the emissions from an intentional radiator shall not exceed the field strength levels specified in the following table:

Frequency (MHz)	Field Strength (uV/m)	Measurement Distance (m)
0.009 - 0.490	2400/F(kHz)	300
0.490 - 1.705	24000/F(kHz)	30
1.705 - 30.0	30	30
30 - 88	100 **	3
88 - 216	150 **	3
216 - 960	200 **	3
Above 960	500	3

** Except as provided in paragraph (g), fundamental emissions from intentional radiators operating under this Section shall not be located in the frequency bands 54-72 MHz, 76-88 MHz, 174-216 MHz or 470-806 MHz. However, operation within these frequency bands is permitted under other sections of this Part, e.g., Sections 15.231 and 15.241.

(4) Restricted Band

Frequency (MHz)	Frequency (MHz)	Frequency (MHz)	Frequency (MHz)
0.090 - 0.110	37.475 - 38.275	1435.0 - 1626.5	8025.0 - 8500.0
¹ 0.490 - 0.510	73.500 - 75.400	1660.0 - 1755.0	9000.0 - 9200.0
2.172 - 2.198	108.00 - 138.00	1805.0 - 1850.0	9300.0 - 9500.0
3.013 - 3.033	149.90 - 150.05	2200.0 - 2300.0	10600 - 12700
4.115 - 4.198	156.70 - 156.90	2310.0 - 2390.0	13250 - 13400
5.670 - 5.690	162.01 - 167.17	2483.5 - 2500.0	14470 - 14500
6.200 - 6.300	167.72 - 173.20	2655.0 - 2900.0	15350 - 16200
8.230 - 8.400	240.00 - 285.00	3260.0 - 3267.0	17700 - 21400
12.265 - 12.600	322.00 - 335.40	3332.0 - 3339.0	22010 - 23120
13.340 - 13.430	399.90 - 410.00	3345.8 - 3358.0	23600 - 24000
14.965 - 15.020	608.00 - 614.00	3500.0 - 4400.0	31200 - 31800
16.700 - 16.755	825.00 - 915.00	4500.0 - 5250.0	36430 - 36500
19.965 - 20.020	935.00 - 1240.0	5350.0 - 5460.0	38600 以上
25.500 - 25.700	1300.0 - 1427.0	7250.0 - 7750.0	

¹ Until February 1, 1999, this restricted band shall be 0.490-0.510 MHz.

1.5 The Support Units

No.	Unit	Model No./ Serial No.	FCC ID	Trade Name	Power Cord	Supported by lab.
1	PC	HP Pavilion t123d/ TW31720114	DoC	HP	1.8m	✓
2	LCD Monitor	173v/ GY17H9NWB53515W	DoC	SAMSUNG	1.8m	✓
3	PS2 Keyboard	5181/ BD11300184	DoC	HP	1.7m	✓
4	Modem	DM-1414/ 0406031779	IFAXDM1414	ACEEX	1.9m	✓
5	Printer	C20SX/ DW4E128191	N/A	EPSON	1.9m	✓

1.6 Layout of Setup

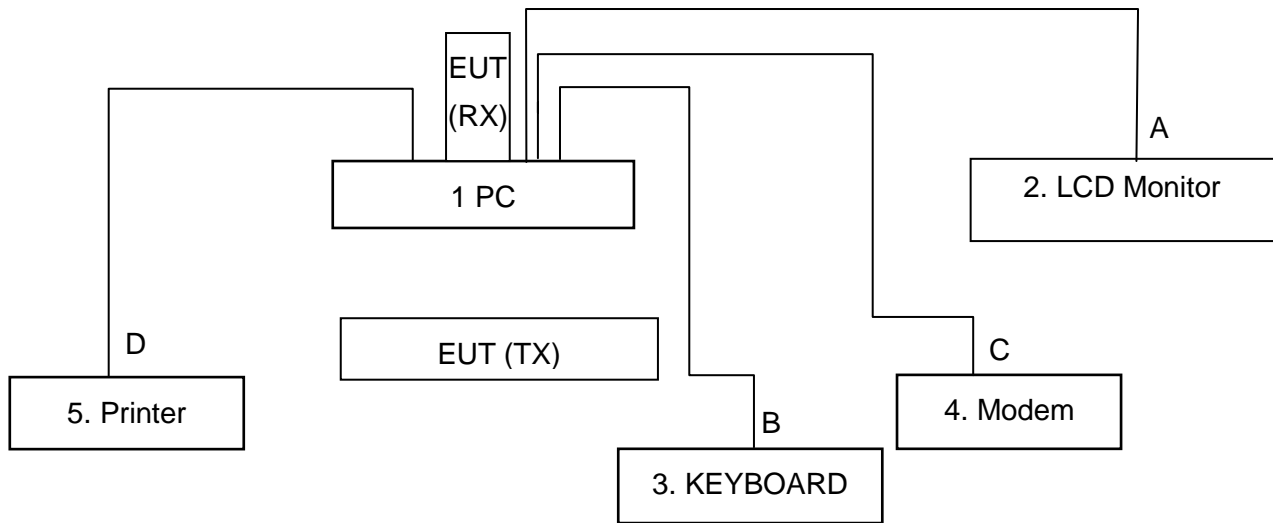

Connecting Cables :

No.	Cable	Length	Shielded	Core	Shielded Backshell	Supported by lab.	Note
A	VGA Cable	1.0m	✓	✓		✓	
B	PS/2 Keyboard Cable	1.8m	✓			✓	
C	Serial Cable	1.9m				✓	
D	printer cable	1.8m	✓			✓	

Justification:

For both conducted and radiated emission below 1GHz, the system was configured for typical fasion as a customer could normal use it.

For radiated emission, measurement of radiated emission from digital circuit is performed with normal transmitting.

1.7 Test Facility

Test Room	Type of Test Room	Descriptions
<input checked="" type="checkbox"/> TR1	10m semi-anechoic chamber (23m×14m×9m)	Complying with the NSA requirements in documents CISPR 22 and ANSI C63.4. for the radiated emission measurement.
<input type="checkbox"/> TR4	Shielding Room (5m×3m×3m)	For the RF conducted emission measurement.

1.8 Measurement Uncertainty

All the measurement uncertainty evaluation procedures in this report are base on ETSI TR 100 028-1, 100 028-2,and ETSI TR 102 273-3. The assessed measurement uncertainties are:

Test Item	Measurement Uncertainty
Field strength of fundamental	Horizontal 4.05dB ; Vertical 4.08dB
Radiated Emission	Horizontal 4.05dB ; Vertical 4.08dB

2 Field Strength of fundamental

Result: Pass

2.1 Applied standard

According to 15.227(a), The field strength of any emission within this band shall not exceed 10,000 microvolts/meter at 3 meters. The emission limit in this paragraph is based on measurement instrumentation employing an average detector. The provisions in Section 15.35 for limiting peak emissions apply

2.2 Measurement Procedure

- a. The EUT was set up per the test configuration figured in the next section of this chapter to simulate the typical usage per the user's manual.
- b. If the EUT is tabletop equipment, it was placed on a wooden table with a height of 0.8 meters above the reference ground plane in the semi-anechoic chamber. If the EUT is floor-standing equipment, it was placed on a non-conducted support with a height of 0.1 meters above the reference ground plane in the semi-anechoic chamber.
- c. The EUT was set 3m away from the interference receiving antenna.
- d. Rapidly sweep the signal in the test frequency range by using the spectrum through the Maximum-peak detector.
- e. Rotate the EUT from 0° to 360° and position the receiving antenna at heights from 1 to 4 meters above the reference ground plane continuously to determine the fundamental frequency and compare the maximum level with the required limit.
- f. Finely tune the antenna and turntable around the recorded position of fundamental frequency found from step f.
- g. Record the frequency and polarization of the receiving antenna and compare the maximum level with the required limit.

2.3 Test configuration

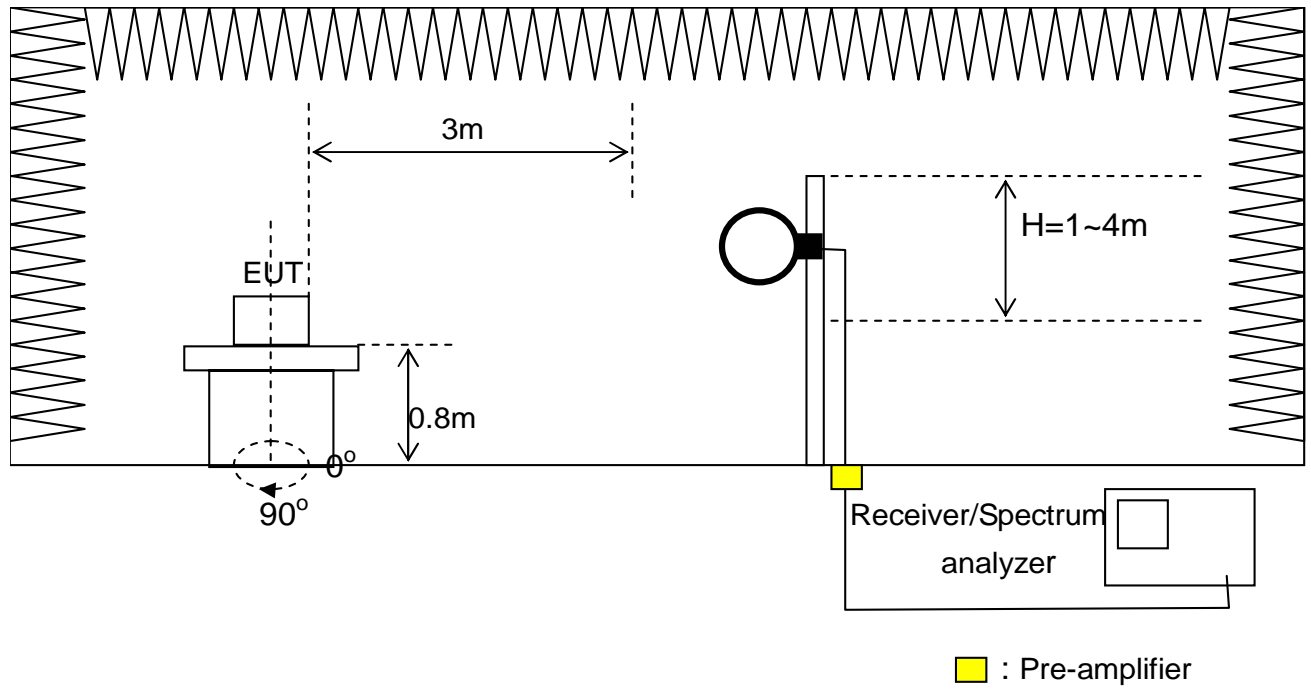

2.4 Test Instruments

Test Site and Equipment	Manufacturer	Model No./Serial No.	Last Cal.
Semi-anechoic Chamber	ETS.LINDGREN	TR1/17627-B	April 11,2004
Spectrum Analyzer	R&S	FSP40/100031	June 8,2004
Antenna	EMCO	6502/ 00042960	Jan 14,2005
Pre-amplifier	Mini Circuit	ZKL-2/ 001	April 17,2004

Note :

1. The calibration interval of the above test equipment is one year and the calibrations are traceable to NML/ROC.
2. NCR:No Calibration Required

Instrument Setting

RBW	VBW	Detector	Trace	Comment
9KHz	10KHz	Peak/Average	Maxhold	

Climatic Condition

Ambient Temperature : 24°C;

Relative Humidity : 55%

2.5 Test Data

Field Strength of Fundament

Test Distance : 10m Tester : Hata

Frequency (MHz)	Polarization	Reading Data (dBuV)		Correction Factor (dB/m)	Output Field Strength (dBuV/m)		Limit @10m (dBuV/m)		Margin (dB)	
		PK	AV		PK	AV	PK	AV	PK	AV
27.046	V	61.32	59.90	-18.49	42.83	41.41	89.54	69.54	57.17	38.59
27.046	H	54.66	53.17	-18.49	36.17	34.68	89.54	69.54	63.83	45.32

Note :

1. Correction Factor (dB/m) = Cable Loss + Antenna Factor – Gain of Preamplifier
2. Output Field Strength (dBuV/m) = Reading Data + Correction Factor
3. Limit@10m=Limit @3m * 3/10 = 3000 uV/m = 69.54 dBuV/m
3. Margin (dB) = Limit – Output Field Strength

V Polarization, PK

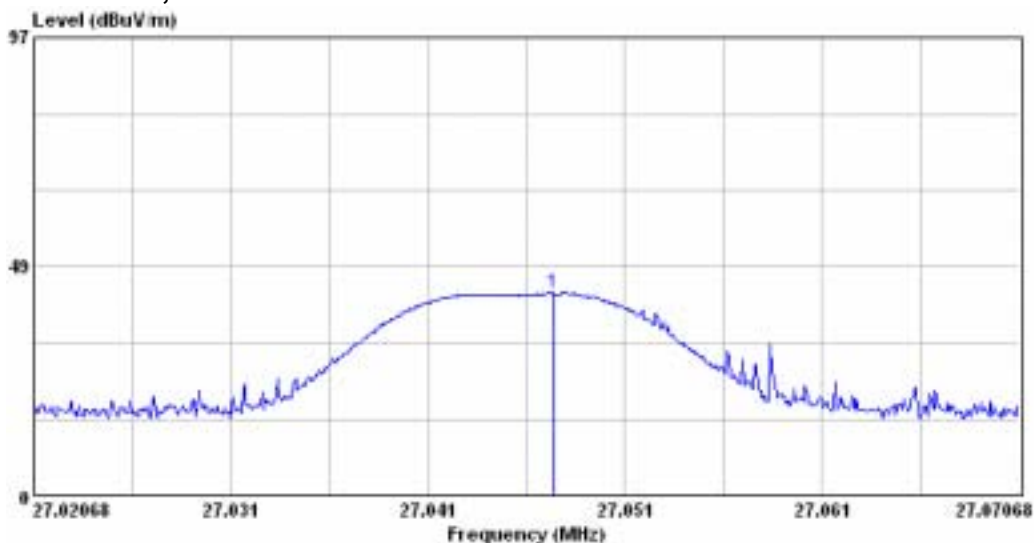

V Polarization, AV

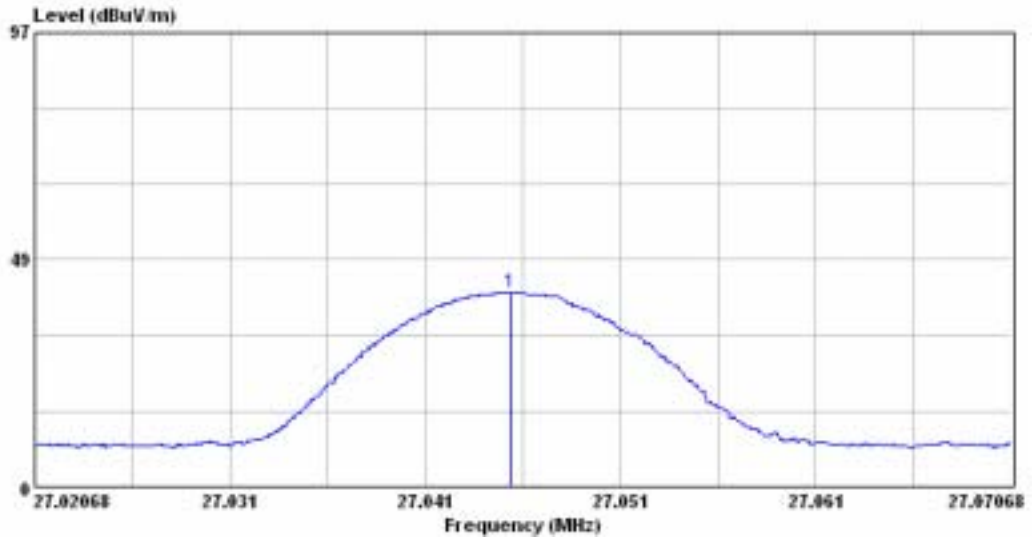

H Polarization, PK

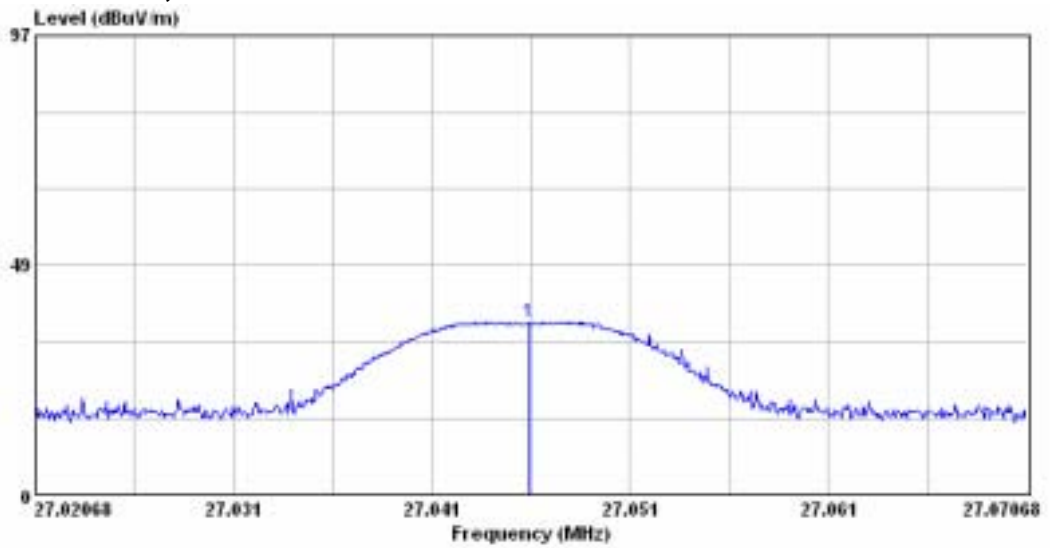

H Polarization, AV

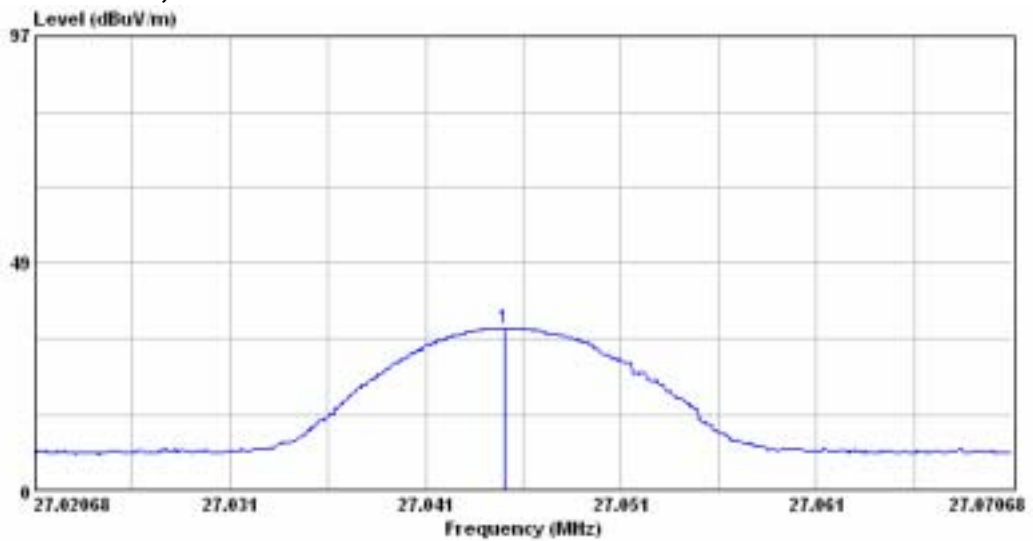

3 Radiated Emission

Result: Pass

3.1 Applied standard

According to 15.231(b), The field strength of any emissions which appear outside of this band shall not exceed the general radiated emission limits in Section 15.209

Frequency (MHz)	Field Strength (uV/m)	Measurement Distance (m)
0.009 - 0.490	2400/F(kHz)	300
0.490 - 1.705	24000/F(kHz)	30
1.705 - 30.0	30	30
30 - 88	100 **	3
88 - 216	150 **	3
216 - 960	200 **	3
Above 960	500	3

** Except as provided in paragraph (g), fundamental emissions from intentional radiators operating under this Section shall not be located in the frequency bands 54-72 MHz, 76-88 MHz, 174-216 MHz or 470-806 MHz. However, operation within these frequency bands is permitted under other sections of this Part, e.g., Sections 15.231 and 15.241.

3.2 Measurement Procedure

- a. The EUT was set up per the test configuration figured in the next section of this chapter to simulate the typical usage per the user's manual.
- b. If the EUT is tabletop equipment, it was placed on a wooden table with a height of 0.8 meters above the reference ground plane in the semi-anechoic chamber. If the EUT is floor-standing equipment, it was placed on a non-conducted support with a height of 0.1 meters above the reference ground plane in the semi-anechoic chamber.
- c. The EUT was set 3m away from the interference receiving antenna.
- d. Rapidly sweep the signal in the test frequency range by using the spectrum through the Maximum-peak detector.
- e. Rotate the EUT from 0° to 360° and position the receiving antenna at heights from 1 to 4 meters above the reference ground plane continuously to determine the fundamental frequency and frequencies associated with higher emission levels and record them.
- f. Then measure each frequency found from step e. by using the spectrum with rotating the EUT and positioning the receiving antenna height to determine the maximum level.
- g. Finely tune the antenna and turntable around the recorded position of each frequency found from step f.
- h. For measurement of frequency below 1000MHz, set the receiver detector to be Quasi-Peak per CISPR 16-1 to find out the maximum level occurred.
- i. For measurement of frequency above 1000MHz, set the spectrum detector to be Peak or Average to find out the maximum level occurred, if any.
- j. Record the frequency and polarization of the receiving antenna and compare the maximum level with the required limit.
- k. Change the receiving antenna to another polarization to measure radiated emission by following step d. to j. again.
- l. If the peak emission level measured from step e. is 10dB lower than the limit specified, then the emission values presented will be the peak value only. Otherwise, accurate Q.P. value will be measured and presented.

3.3 Test configuration

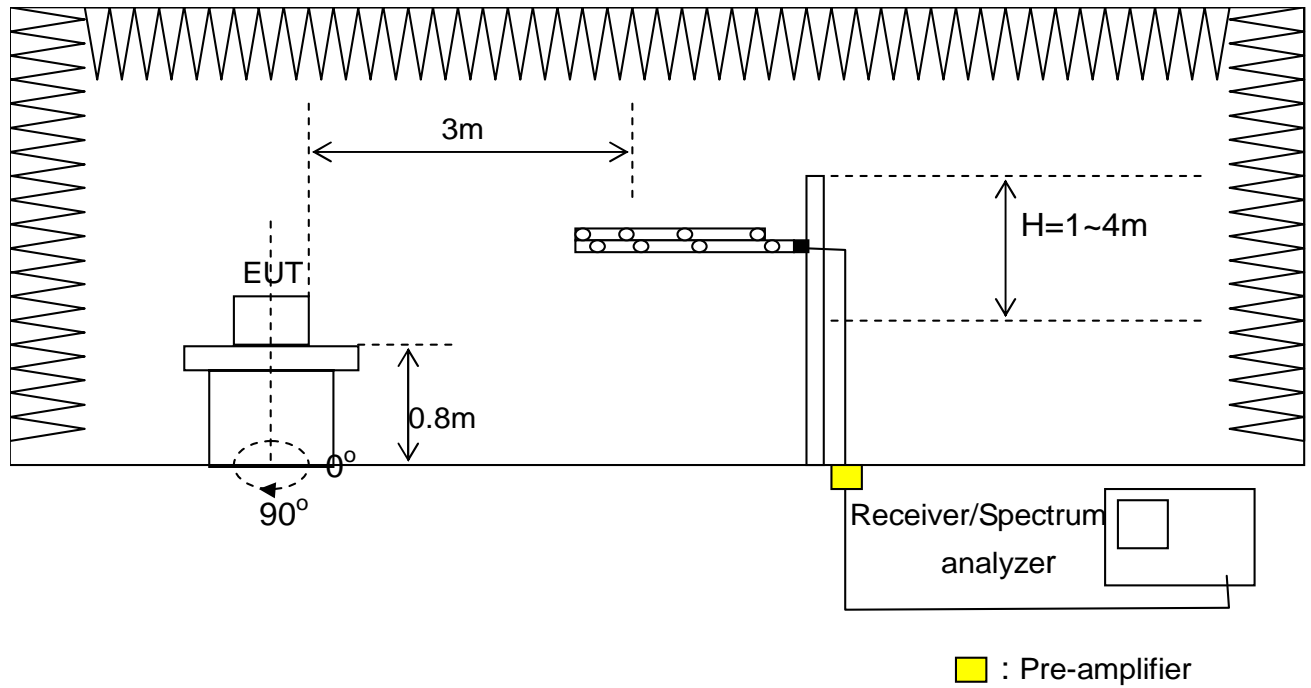

3.4 Test Instruments

Test Site and Equipment	Manufacturer	Model No./Serial No.	Last Cal.
Semi-anechoic Chamber	ETS.LINDGREN	TR1/17627-B	April 11,2004
Test Receiver	R&S	ESCS30/ 836858/020	July 21,2004
Antenna			
Antenna	R&S	HL562/ 360543/006	May 27,2004
Pre-amplifier	Mini Circuit	ZKL-2/ 001	April 17,2004

Note :

1. The calibration interval of the above test equipment is one year and the calibrations are traceable to NML/ROC.
2. NCR:No Calibration Required

Instrument Setting

RBW	VBW	Detector	Trace	Comment
120kHz	N/A	Quasi-Peak	Maxhold	

Climatic Condition

Ambient Temperature : 24°C;

Relative Humidity : 55%

3.5 Test Data

Test Distance : 3m Tester : Hata
 Polarization : Vertical Frequency Range : 27MHz~300MHz

	Freq. (MHz)	Reading Data (dBuV)	Correction Factor (dB/m)	Emission Level (dBuV/m)	Limit (dBuV/m)	Margin (dB)
1	30.00	40.58	-10.65	29.93	40.00	10.07
2	36.21	42.31	-11.48	30.83	40.00	9.17
3	66.45	49.27	-22.59	26.68	40.00	13.32
4	248.70	50.60	-18.21	32.39	46.00	13.61
5	270.57	50.76	-16.78	33.98	46.00	12.02
6	297.57	51.57	-16.08	35.49	46.00	10.51

Note :

1. Correction Factor (dB/m) = Cable Loss + Antenna Factor – Gain of Preamplifier
2. Emission Level (dBuV/m) = Reading Data + Correction Factor
3. Margin (dB) = Limit – Emission Level
4. “**”: The emission is too low to be measured.

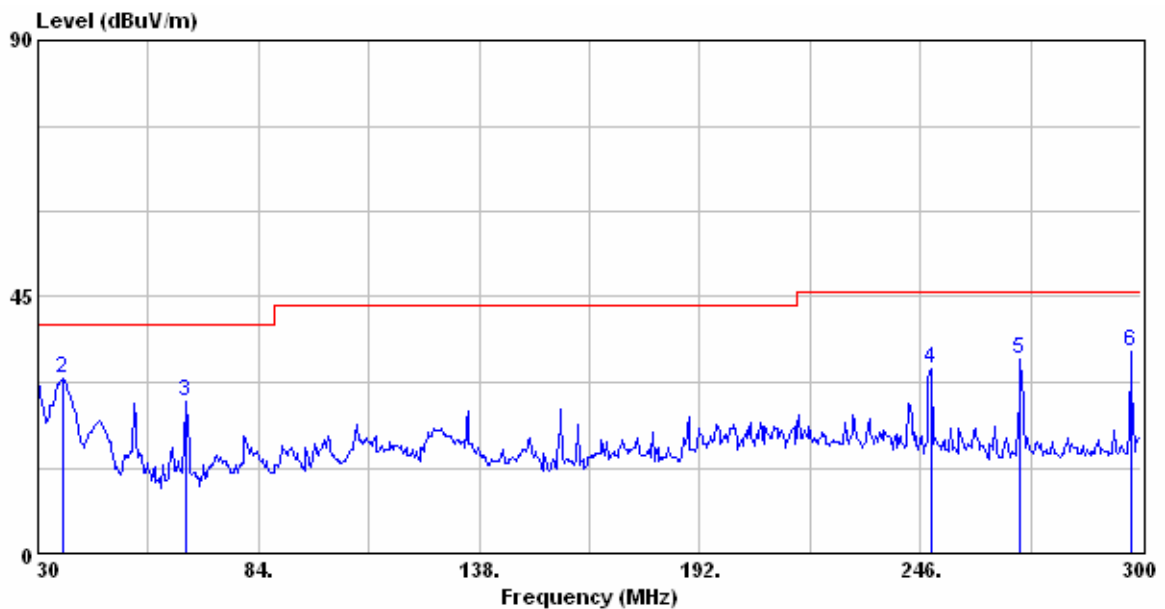

參照頁 (非報告一部分,列印時不列印此參照頁)

報告編號 : RF-J19-0412-197
 受測產品 : Wireless Optical Mouse
 廠牌 : Agiler
 型號 : SAXM105A1
 製造者 : Shanghai Sysgration Industrial Co.Ltd
 申請者 : Sysgration Ltd.
 申請者地址 : 10F1.,No.868-3,Chung Cheng Rd.,Chung Ho,Taipei (235),Taiwan,R.O.C
 申請者電話 : (02) 82217111
 收件日期 : December 22, 2004
 測試日期 : December 23, 2004
 報告日期 : December 24, 2004
 發射器 : 遙控器
 接收器 : 接收機
 發射功率(電場強度) : 27.90dBuV/m
 工作頻率 : 見第 4 頁
 天線規格 : 見第 19 頁
 額定輸入電壓 : DC 3V (發射機); 5V (接收機)
 測試輸入電壓 : DC 3V(發射機 2 顆 AAA 電池); 5V (接收機 USB)
 頻率範圍 : 27.05MHz
 調變技術 :
 溫度 : 24°C
 溼度 : 65%
 TR1 測試員 : Hata
 TR4 測試員 : Bill
 TR5 測試員 : Bill

設備名稱	製造商	型號/序號	上次校驗日期
TR1			April 11,2004
TR4			NCR
TR5			NCR
頻譜分析儀	R&S	FSP40/100031	June 8,2004
接收機	R&S	ESCS30/ 836858/020	July 21,2004
天線	R&S	HL562/ 360543/006	May 27,2004
天線 906	R&S	HF906/ 359287/001	April 26,2004
天線 3116	EMCO	3116/ 20552	May 27,2004
前置放大器	MITEQ	JS4-00101800-28-5A/ 742229	March 14,2004
前置放大器	MITEQ	JS4-18002600-30-5A/ 741923	April 13,2004
前置放大器	MITEQ	ZKL-2/ 001	April 17,2004
高通濾波器	MCI	H04G13G1/2467-01	March 1,2004
衰減器	HP	8495B/ 2814A13358	Decemebr 29,2004
接收機	R&S	ESCS30/ 836858/021	Jauary 6,2005
電源阻抗模擬網路	R&S	ESH2-Z5/ 836613/001	Jauary 4,2005
電源阻抗模擬網路	R&S	ENV4200/ 833209	Jauary 4,2005
量測項目	量測不確定度		

峰值輸出功率	水平極化 4.62 dB ; 垂直極化 4.56 dB
頻帶邊緣	水平極化 4.62dB ; 垂直極化 4.56dB
載波頻率頻道間隔	4.56 Hz
不必要之發射: 輻射發射測試 (1GHz 以下)	水平極化 4.05dB ; 垂直極化 4.08dB
不必要之發射: 輻射發射測試 (1GHz 以上)	水平極化 4.58 dB ; 垂直極化 4.62 dB
交流電力線傳導發射測試	2.26 dB