



Product Name: Wireless Optical Mouse
Model No.: AXM-105xxx, AXM-A5xxx, ARM-105xxx, ARM-A5xxx
AGM-105xxx, AGM-A5xxx, AKM-105C35xxx,
AKM-A5C35xxx, XM-173, 57288
AXM-106xxx, AXM-A6xxx, ARM-106xxx, ARM-A6xxx
AGM-106xxx, AGM-A6xxx, AKM-106C35xxx,
AKM-A6C35xxx
AXM-107xxx, AXM-A7xxx, ARM-107xxx, ARM-A7xxx
AGM-107xxx, AGM-A7xxx, AKM-107C35xxx,
AKM-A7C35xxx
AXM-108xxx, AXM-A8xxx, ARM-108xxx, ARM-A8xxx
AGM-108xxx, AGM-A8xxx, AKM-108C35xxx,
AKM-A8C35xxx, SYMS-1607
Trade Name: Agiler, Sysgration
Applicant: Sysgration Ltd.
10Fl., No. 868-3, Chung Cheng Rd., Chung Ho,
Taipei (235), Taiwan, R.O.C.
Date of Receipt: Nov. 05, 2003
Finished date of Test: Nov. 20, 2003
Applicable Standards: 47 CFR Part 15, Subpart C
ANSI C63.4:1992

We, **Spectrum Research & Testing Laboratory Inc.**, hereby certify that one sample of the above was tested in our laboratory with positive results according to the above-mentioned standards. The records in the report are an accurate account of the results. Details of the results are given in the subsequent pages of this report.

Checked By :

Sunyou Chen
(Sunyou Chen)

Date:

11/21/2003

Approved By :

J Ho
(Johnson Ho, Director)

Date:

11/21/2003



Table of Contents

1.	DOCUMENT POLICY AND TEST STATEMENT	3
1.1	DOCUMENT POLICY	3
1.2	TEST STATEMENT	3
2.	DESCRIPTION OF EUT AND TEST MODE	4
2.1	GENERAL DESCRIPTION OF EUT	4
2.2	DESCRIPTION OF EUT INTERNAL DEVICE	5
2.3	DESCRIPTION OF TEST MODE	5
2.4	DESCRIPTION OF SUPPORT UNIT	6
3.	DESCRIPTION OF APPLIED STANDARDS	6
4.	CONDUCTED EMISSION TEST	7
4.1	CONDUCTED EMISSION LIMIT	7
4.2	TEST EQUIPMENT	7
4.3	TEST SETUP	8
4.4	TEST PROCEDURE	8
4.5	EUT OPERATING CONDITION	8
4.6	TEST RESULT	9
5.	RADIATED EMISSION TEST	12
5.1	RADIATED EMISSION LIMIT	12
5.2	TEST EQUIPMENT	13
5.3	TEST SET-UP	14
5.4	TEST PROCEDURE	15
5.5	EUT OPERATING CONDITION	15
5.6	RADIATED EMISSION TEST RESULT	16
6.	BAND EDGE	21
6.1	BAND EDGE LIMIT	21
6.2	TEST EQUIPMENT	21
6.3	TEST SET-UP	21
6.4	TEST PROCEDURE	21
6.5	EUT OPERATING CONDITION	21
6.6	BAND EDGE TEST RESULT	22
7.	PHOTOS OF TESTING	23
8.	TERMS OF ABRIVATION	29



**Spectrum Research
& Testing Lab., Inc.**

No. 101-10, Ling 8,
Shan-Tong Li, Chung-Li
City, Taoyuan, Taiwan,
R.O.C.

TEST REPORT

Reference No.:A03110506

Report No.:FCCA03110506

Page:3 of 29

Date:Nov. 21, 2003

1. DOCUMENT POLICY AND TEST STATEMENT

1.1 DOCUMENT POLICY

- The report shall not be reproduced except in full, without the written approval of SRT Lab, Inc.
- The report must not be used by the applicant to claim that the product is endorsed by NVLAP, TÜV, NEMKO and SRT.
- The NVLAP logo applies only to the applicable standards specified in this report.

1.2 TEST STATEMENT

- The test results in the report apply only to the unit tested by SRT Lab.
- There was no deviation from the requirements of test standards during the test.
- AC power source, 120 Vac/60 Hz, was used during the test.



2. DESCRIPTION OF EUT AND TEST MODE

2.1 GENERAL DESCRIPTION OF EUT

PRODUCT	Wireless Optical Mouse
TRADE NAME	Agiler, Sysgration
MODEL NO.	AXM-105xxx, AXM-A5xxx, ARM-105xxx, ARM-A5xxx, AGM-105xxx, AGM-A5xxx, AKM-105C35xxx, AKM-A5C35xxx, XM-173, 57288 AXM-106xxx, AXM-A6xxx, ARM-106xxx, ARM-A6xxx, AGM-106xxx, AGM-A6xxx, AKM-106C35xxx, AKM-A6C35xxx AXM-107xxx, AXM-A7xxx, ARM-107xxx, ARM-A7xxx, AGM-107xxx, AGM-A7xxx, AKM-107C35xxx, AKM-A7C35xxx AXM-108xxx, AXM-A8xxx, ARM-108xxx, ARM-A8xxx, AGM-108xxx, AGM-A8xxx, AKM-108C35xxx, AKM-A8C35xxx, SYMS-1607

RF Mouse Transmitter

WORKING FREQUENCY	27.045MHz
CHANNEL NUMBER	1
ID NUMBERS	256
RF OUTPUT POWER	-4dBm±2dBm
DEVIATION	6KHz±2KHz
MODULATION METHOD	FSK
POWER REQUIREMENTS	3.0V, AAA size (Ni-MH) batteries x2
CURRENT DISSIPATION	<30mA
STANDBY MODE CURRENT	5±1mA
SLEEPING MODE CURRENT	0.63mA
TRANSMITTING ANGLE	360 °
WORKING DISTANCE	1.0 meter (Min.)
CHARGER CURRENT	300mA(Max.)
CHARGE TIME	4 Hours (Min.)
LOW BATTERY	1.9V

RF Receiver

WORKING FREQUENCY	27MHz
CHANNEL NUMBER	1
ID NUMBERS	256
CURRENT DISSIPATION	15mA (Typ)
WORKING DISTANCE	1.0 meter (Min.)



NOTE :

The difference between following models as follows:

(The "x" in the model numbers can be 0-9, A-Z or blank. It is indicated that different between color of enclosure and customer)

Mold	Option	Model Name	Receiver
105	For Mouse	AXM-105xxx, AXM-A5xxx, AGM-105xxx, AGM-A5xxx, XM-173, 57288, SYMS-1607	Mini Receiver
	For K+M	ARM-105xxx, ARM-A5xxx, AKM-105C35xxx, AKM-A5C35xxx	K+M Receiver
106	For Mouse	AXM-106xxx, AXM-A6xxx, AGM-106xxx, AGM-A6xxx	Mini Receiver
	For K+M	ARM-106xxx, ARM-A6xxx, AKM-106C35xxx, AKM-A6C35xxx	K+M Receiver
107	For Mouse	AXM-107xxx, AXM-A7xxx, AGM-107xxx, AGM-A7xxx	Mini Receiver
	For K+M	ARM-107xxx, ARM-A7xxx, AKM-107C35xxx, AKM-A7C35xxx	K+M Receiver
108	For Mouse	AXM-108xxx, AXM-A8xxx, AGM-108xxx, AGM-A8xxx	Mini Receiver
	For K+M	ARM-108xxx, ARM-A8xxx, AKM-108C35xxx, AKM-A8C35xxx	K+M Receiver

The product is a wireless optical mouse that includes wireless mouse (transmitter part (Tx)), USB dongle (receiver part (RX)) and a transmitter cable. For more detailed features, please refer to the manufacturer's specification or User's Manual.

2.2 DESCRIPTION OF EUT INTERNAL DEVICE

DEVICE	BRAND / MAKER	MODEL #	FCC ID/DOC	REMARK
N/A				

2.3 DESCRIPTION OF TEST MODE

The EUT was tested for emission measurement under the following situations:

Mode	EUT collocation
1	Mouse+Receiver
2	Mouse+USB Dongle
3	Mouse+USB Dongle+Transmitter cable



2.4 DESCRIPTION OF SUPPORT UNIT

The EUT was configured by the requirement of ANSI C63.4:1992 and CISRP22:1997. All interface ports were connected to the appropriate support units via specific cables. The support units and cables are listed below.

NO	DEVICE	BRAND	MODEL #	FCC ID/DOC	CABLE
1	Monitor	SAMSUNG	PG17IS	DOC	1.8m unshielded power cord
2	Modem	ACEEX	DM-1414	DOC	1.5m unshielded power cord 1.2m shielded data cable
3	Printer	EPSON	STYLUS C20SX	DOC	1.5m unshielded power cord 1.2m shielded data cable
4	Keyboard	ACER	6311-TA	DOC	1.5m unshielded data cable
5	PC System	ACER	Veriton 7600G	DOC	1.5m unshielded power cord

NOTE : For the actual test configuration, please refer to the photos of testing.

3. DESCRIPTION OF APPLIED STANDARDS

The EUT is a kind of wireless product and to be connected with a PC system for normal use. According to the specifications provided by the applicant, it must comply with the requirements of the following standards:

47 CFR Part 15, Subpart C
ANSI C63.4:1992

All tests have been performed and recorded as per the above standards.



4. CONDUCTED EMISSION TEST

4.1 CONDUCTED EMISSION LIMIT

FREQUENCY (MHz)	Class A (dBmV)		Class B (dBmV)	
	Quasi-peak	Average	Quasi-peak	Average
0.15 - 0.5	79	66	66 - 56	56 - 46
0.5 - 5.0	73	60	56	46
5.0 - 30.0	73	60	60	50

NOTE:

1. The lower limit shall apply at the transition frequencies.
2. The limit decreases in line with the logarithm of the frequency in the range of 0.15 to 0.50 MHz.

4.2 TEST EQUIPMENT

The following test equipment was used for the test:

EQUIPMENT/ FACILITIES	SPECIFICATIONS	MANUFACTURER	MODEL#/ SERIAL#	DUE DATE OF CAL. & CAL. CENTER
EMI TEST RECEIVER	9 kHz TO 2750 MHz	ROHDE & SCHWARZ	ESCS30/ 830245/012	AUG. 2004 ETC
LISN (for EUT)	50 μH, 50 ohm	SOLAR ELECTRONICS	8012-50-R-24-BNC / 924839	JUN. 2004 ETC
LISN (for Peripheral)	50μH, 50 ohm	SOLAR ELECTRONICS	9252-50-R-24-BNC / 951318	JUN. 2004 ETC
50 ohm TERMINATOR	50 ohm	HP	11593A/ 2	MAY 2004 ETC
COAXIAL CABLE	3m	SUNCITY	J400/ 3M	JUL. 2004 SRT
ISOLATION TRANSFORMER	N/A	APC	AFC-11015/ F102040016	N/A
FILTER	2 LINE, 30A	FIL.COIL	FC-943/ 771	N/A
GROUND PLANE	2.3M (H) x 2.4M (W)	SRT	N/A	APR. 2004 SRT
GROUND PLANE	2.4M (H) x 2.4M (W)	SRT	N/A	APR. 2004 SRT

NOTE: The calibration interval of the above test equipment is one year and the calibrations are traceable to NML/ROC and NIST/USA.



4.3 TEST SETUP

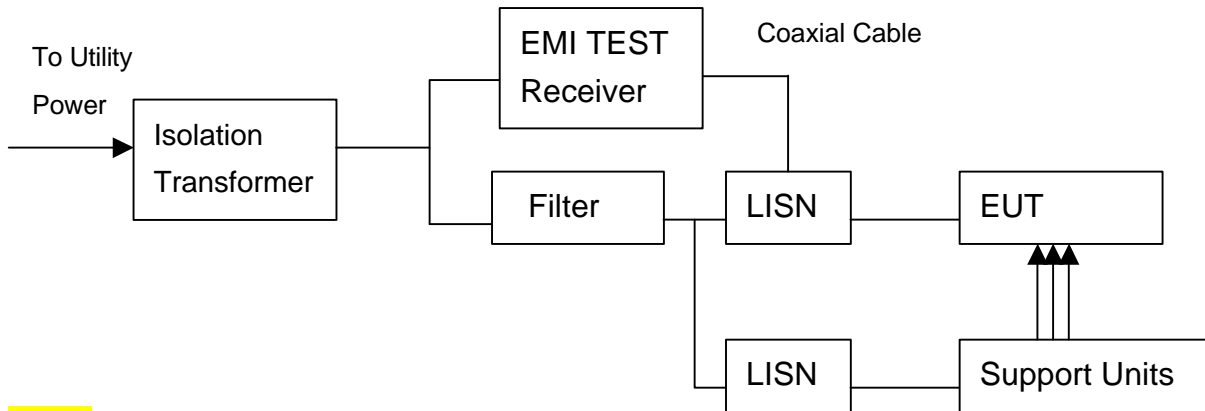

NOTE:

1. The EUT was put on a wooden table with 0.8m height above ground plane, and 0.4m away from reference ground plane (> 2mx2m).
2. For the actual test configuration, please refer to the photos of testing.
3. The serial no. of the LISN connected to EUT is 951318.
4. The serial no. of the LISN connected to support units is 924839.

4.4 TEST PROCEDURE

The EUT was tested according to the requirement of ANSI C63.4:1992 and CISRP22:1997. The frequency spectrum from 0.15 MHz to 30 MHz was investigated. The LISN used was 50 ohm/50 μ H as specified. All readings were quasi-peak and average values with 10 kHz resolution bandwidth of the test receiver. The EUT system was operated in all typical methods by users. Both lines of the power mains of EUT were measured and the cables connected to EUT and support units were moved to find the maximum emission levels for each frequency. First, Find the margin or higher points at least 6 points by software, then use manual to find the maximum data. The procedure is referred on the test procedure of SRT LAB.

4.5 EUT OPERATING CONDITION

1. Under Windows XP run "EMI TEST" program and PC sent "H" pattern or accessed the following peripherals directly or via EUT:
 - Color Monitor
 - RS232
 - Keyboard
 - EUT (TX)
 - Printer
 - FDD
 - HDD



4.6 TEST RESULT

Temperature:	<u>26°C</u>	Humidity:	<u>55 %RH</u>
Ferquency Range:	<u>0.15 – 30 MHz</u>	Tested Mode:	<u>1 (Mouse+Receiver)</u>
Receiver Detector:	<u>Q.P. and AV.</u>	Tested By:	<u>Yujeng Wu</u>
		Tested Date:	<u>Nov. 18, 2003</u>

Power Line Measured : Line

Freq. (MHz)	Correct. Factor (dB)	Reading Value (dBmV)		Emission Level (dBmV)		Limit (dBmV)		Margin (dB)	
		Q.P.	AV.	Q.P.	AV.	Q.P.	AV.	Q.P.	AV.
0.154	0.20	51.4	24.4	51.6	24.6	65.8	55.8	-14.2	-31.2
0.373	0.20	35.9	32.6	36.1	32.8	58.4	48.4	-22.3	-15.6
0.939	0.20	35.7	34.9	35.9	35.1	56.0	46.0	-20.1	-10.9
1.248	0.20	31.1	30.0	31.3	30.2	56.0	46.0	-24.7	-15.8
2.185	0.20	29.8	27.1	30.0	27.3	56.0	46.0	-26.0	-18.7
17.498	0.55	28.5	20.0	29.0	20.5	60.0	50.0	-31.0	-29.5

Power Line Measured : Neutral

Freq. (MHz)	Correct. Factor (dB)	Reading Value (dBmV)		Emission Level (dBmV)		Limit (dBmV)		Margin (dB)	
		Q.P.	AV.	Q.P.	AV.	Q.P.	AV.	Q.P.	AV.
0.201	0.20	41.2	40.8	41.4	41.0	63.6	53.6	-22.2	-12.6
0.377	0.20	33.8	31.3	34.0	31.5	58.3	48.3	-24.3	-16.8
0.939	0.20	34.5	33.9	34.7	34.1	56.0	46.0	-21.3	-11.9
1.427	0.20	31.9	30.2	32.1	30.4	56.0	46.0	-23.9	-15.6
3.431	0.24	28.5	23.2	28.7	23.4	56.0	46.0	-27.3	-22.6
4.673	0.31	30.5	24.8	30.8	25.1	56.0	46.0	-25.2	-20.9

NOTE :

1. Measurement uncertainty is +/-3dB
2. Emission level = Reading value + Correction factor
3. Correction Factor = Cable loss + Insertion loss of LISN
4. Margin value = Emission level - Limit
5. The emission of other frequencies were very low against the limit.
6. "-": The Quasi-peak reading value also meets average limit and measurement with the average detector is unnecessary.



Temperature:	<u>26° C</u>	Humidity:	<u>55 %RH</u>
Ferquency Range:	<u>0.15 – 30 MHz</u>	Tested Mode:	<u>2 (Mouse+USB Dongle)</u>
Receiver Detector:	<u>Q.P. and AV.</u>	Tested By:	<u>Yujeng Wu</u>
		Tested Date:	<u>Nov. 18, 2003</u>

Power Line Measured : Line

Freq. (MHz)	Correct. Factor (dB)	Reading Value (dBmV)		Emission Level (dBmV)		Limit (dBmV)		Margin (dB)	
		Q.P.	AV.	Q.P.	AV.	Q.P.	AV.	Q.P.	AV.
0.177	0.20	44.5	36.1	44.7	36.3	64.6	54.6	-19.9	-18.3
0.373	0.20	33.2	32.9	33.4	33.1	58.4	48.4	-25.0	-15.3
0.939	0.20	36.0	35.1	36.2	35.3	56.0	46.0	-19.8	-10.7
1.423	0.20	32.7	29.6	32.9	29.8	56.0	46.0	-23.1	-16.2
3.755	0.27	29.4	27.4	29.7	27.7	56.0	46.0	-26.3	-18.3
9.095	0.38	28.5	17.1	28.9	17.5	60.0	50.0	-31.1	-32.5

Power Line Measured : Neutral

Freq. (MHz)	Correct. Factor (dB)	Reading Value (dBmV)		Emission Level (dBmV)		Limit (dBmV)		Margin (dB)	
		Q.P.	AV.	Q.P.	AV.	Q.P.	AV.	Q.P.	AV.
0.150	0.20	52.9	23.7	53.1	23.9	66.0	56.0	-12.9	-32.1
0.404	0.20	29.6	29.2	29.8	29.4	57.8	47.8	-28.0	-18.4
0.627	0.20	34.2	34.2	34.4	34.4	56.0	46.0	-21.6	-11.6
1.423	0.20	33.5	29.6	33.7	29.8	56.0	46.0	-22.3	-16.2
3.431	0.24	28.8	25.1	29.0	25.3	56.0	46.0	-27.0	-20.7
8.123	0.37	31.0	23.7	31.4	24.1	60.0	50.0	-28.6	-25.9

NOTE :

1. Measurement uncertainty is +/-3dB
2. Emission level = Reading value + Correction factor
3. Correction Factor = Cable loss + Insertion loss of LISN
4. Margin value = Emission level - Limit
5. The emission of other frequencies were very low against the limit.
6. "-": The Quasi-peak reading value also meets average limit and measurement with the average detector is unnecessary.



Temperature: 26° C Humidity: 55 %RH
 Frequency Range: 0.15 – 30 MHz Tested Mode: 3 (Mouse+USB Dongle +Transmitter cable)
 Receiver Detector: Q.P. and AV. Tested By: Yujeng Wu
 Tested Date: Nov. 18, 2003

Power Line Measured : Line

Freq. (MHz)	Correct. Factor (dB)	Reading Value (dBmV)		Emission Level (dBmV)		Limit (dBmV)		Margin (dB)	
		Q.P.	AV.	Q.P.	AV.	Q.P.	AV.	Q.P.	AV.
0.224	0.20	34.7	33.1	34.9	33.3	62.6	52.6	-27.7	-19.3
0.306	0.20	27.6	26.1	27.8	26.3	60.1	50.1	-32.3	-23.8
0.627	0.20	34.2	34.1	34.4	34.3	56.0	46.0	-21.6	-11.7
1.423	0.20	32.7	29.6	32.9	29.8	56.0	46.0	-23.1	-16.2
4.697	0.31	30.3	25.9	30.6	26.2	56.0	46.0	-25.4	-19.8
11.814	0.44	31.3	21.0	31.7	21.4	60.0	50.0	-28.3	-28.6

Power Line Measured : Neutral

Freq. (MHz)	Correct. Factor (dB)	Reading Value (dBmV)		Emission Level (dBmV)		Limit (dBmV)		Margin (dB)	
		Q.P.	AV.	Q.P.	AV.	Q.P.	AV.	Q.P.	AV.
0.150	0.20	52.7	41.7	52.9	41.9	66.0	56.0	-13.1	-14.1
0.369	0.20	33.4	32.2	33.6	32.4	58.5	48.5	-24.9	-16.1
0.939	0.20	36.2	32.0	36.4	32.2	56.0	46.0	-19.6	-13.8
1.423	0.20	34.1	30.8	34.3	31.0	56.0	46.0	-21.7	-15.0
3.744	0.27	29.5	26.1	29.8	26.4	56.0	46.0	-26.2	-19.6
9.056	0.38	29.3	28.2	29.7	28.6	60.0	50.0	-30.3	-21.4

NOTE :

1. Measurement uncertainty is +/-3dB
2. Emission level = Reading value + Correction factor
3. Correction Factor = Cable loss + Insertion loss of LISN
4. Margin value = Emission level - Limit
5. The emission of other frequencies were very low against the limit.
6. "-": The Quasi-peak reading value also meets average limit and measurement with the average detector is unnecessary.



5. RADIATED EMISSION TEST

5.1 RADIATED EMISSION LIMIT

FCC Part 15, Subpart C Section 15.227.

FREQUENCY (MHz)	DISTANCE (m)	FIELD STRENGTH (dBmV/m)	
		PEAK	AVERAGE
26.96 - 27.28	3	100.0	80.0

FCC Part 15, Subpart B Section 15.209.

FREQUENCY (MHz)	DISTANCE (m)	FIELD STRENGTH (dBmV/m)
30 - 88	3	40.0
88 - 216	3	43.5
216 - 960	3	46.0
Above 960	3	54.0

NOTE :

1. In the emission tables above , the tighter limit applies at the band edges.
2. Distance refers to the distance between measuring instrument, antenna, and the closest point of any part of the device or system.

CISPR 22:1997 limits of radiated emission measurement for frequency below 1000 MHz

FREQUENCY (MHz)	Class A (at 10m)	Class B (at 10m)
	dBµV/m	dBµV/m
30 – 230	40	30
230 - 1000	47	37

NOTE:

1. The lower limit shall apply at the transition frequencies.
2. Emission level (dBµV/m) = 20 log Emission level (µV/m).



5.2 TEST EQUIPMENT

The following test equipment was used during the radiated emission test:

EQUIPMENT/ FACILITIES	SPECIFICATIONS	MANUFACTURER	MODEL#/ SERIAL#	DUE DATE OF CAL. & CAL. CENTER
EMI TEST RECEIVER	20 MHz TO 1000 MHz	ROHDE & SCHWARZ	ESVS30/ 841997/003	AUG. 2004 ETC
BI-LOG ANTENNA	25 MHz TO 2 GHz	EMCO	3142/ 9701-1124	APR. 2004 SRT
OATS	3 – 10 M MEASUREMENT	SRT	SRT-1	APR. 2004 SRT
COAXIAL CABLE	25M	SUNCITY	J400/ 25M	AUG. 2004 SRT
FILTER	2 LINE, 30A	FIL.COIL	FC-943/ 869	N/A
FREQUENCY CONVERTER	N/A	APC	AFC-1KW/ 860612	AUG. 2004 SRT

NOTE:

1. The calibration interval of the above test equipment is one year and the calibrations are traceable to NML/ROC and NIST/USA.
2. The Open Area Test Site (SRT-1) is registered by FCC with No. 90957 and VCCI with No. R-1081.
3. The Open Area Test Site (SRT-2) is registered by FCC with No. 98458 and VCCI with No. R-1168.



5.3 TEST SET-UP

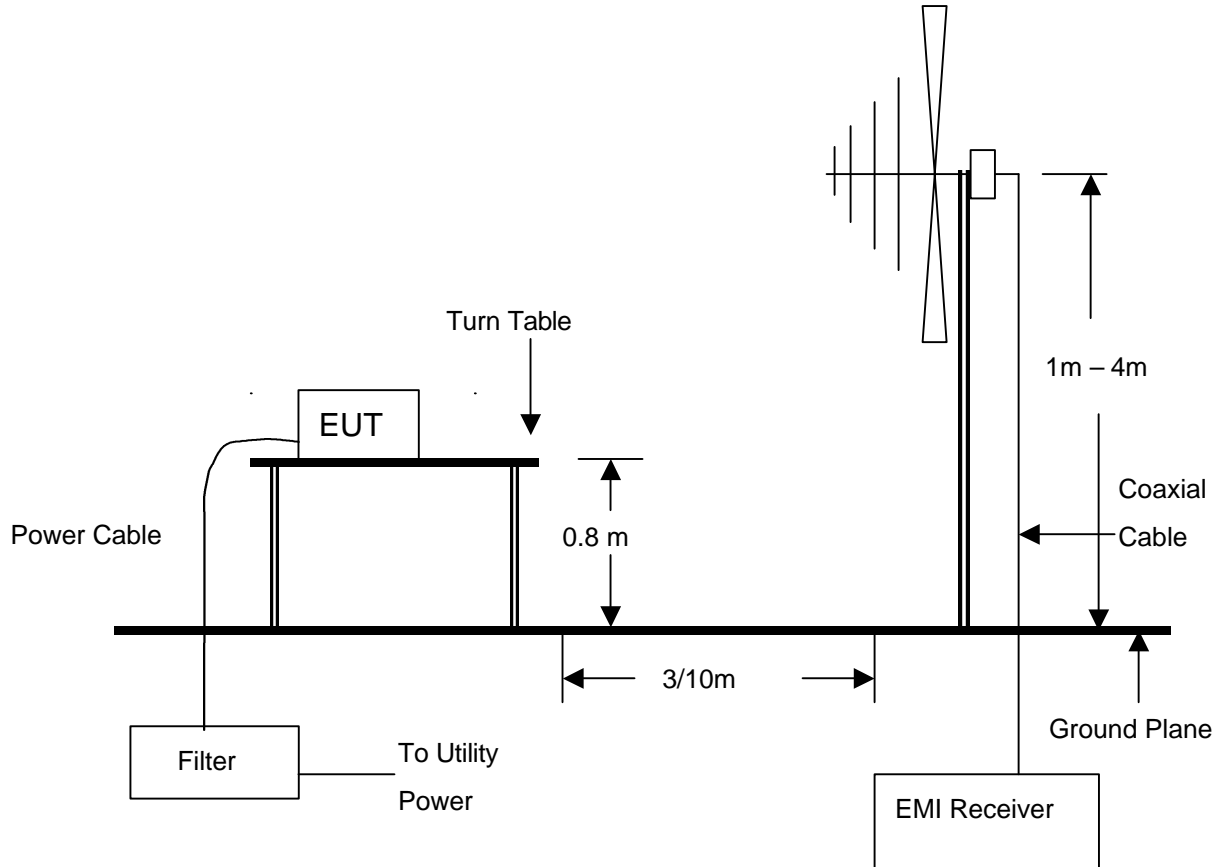

NOTE :

1. The EUT system was put on a wooden table with 0.8m heights above a ground plane.
2. For the actual test configuration, please refer to the photos of testing.



5.4 TEST PROCEDURE

The EUT was tested according to the requirement of ANSI C63.4:1992 and CISPR 22:1997. The measurements were made at an open area test site with 10 meter measurement distance under 1 GHz and with 3m distance above 1GHz. The frequency spectrum measured started from 30 MHz. Under 1 GHz, all readings were quasi-peak values with 120 kHz resolution bandwidth of the test receiver. Above 1 GHz, the measurements were made at an open area test site with 3 meter measurement distance and all readings were peak or average values with 1 MHz resolution bandwidth of the test receiver. The EUT system was operated in all typical methods by users. The cables connected to EUT and support units were moved to find the maximum emission levels for each frequency. First, Find the margin or higher points at least 6 points by software, then use manual to find the maximum data. The procedure is referred on the test procedure of SRT LAB.

5.5 EUT OPERATING CONDITION

Same as section 4.5 of this report.



5.6 RADIATED EMISSION TEST RESULT

Temperature:	<u>26° C</u>	Humidity:	<u>55 %RH</u>
Ferquency Range:	<u>30 - 1000 MHz</u>	Measured Distance:	<u>3m</u>
Receiver Detector:	<u>AV.</u>	Tested Mode:	<u>TX (Fundamental Frequency)</u>
Tested By:	<u>Yujeng Wu</u>		
Tested Date:	<u>Nov. 17, 2003</u>		

Frequency (MHz)	Antenna Polarization	Cable Loss (dB)	Antenna Factor (dB/m)	Reading Data (dB μ V)	Emission Level (dB μ V/m)	Limit (dB μ V/m)	Margin (dB)
27.041(F)	H	1.33	19.40	36.3	57.0	80.0	-23.0
27.041(F)	V	1.33	19.40	44.5	74.5	80.0	-5.5

NOTE :

1. Measurement uncertainty is less than +/- 4dB
2. "**": Measurement does not apply for this frequency.
3. Emission Level = Reading Value + Ant. Factor + Cable Loss
4. The field strength of other emission frequencies were very low against the limit.
5. (F) : Fundamental frequency of transmitter.



Temperature:	26° C	Humidity:	55 %RH
Ferquency Range:	30 – 1000 MHz	Measured Distance:	3m
Receiver Detector:	Q.P.	Tested Mode:	TX
Tested Date:	Nov. 17, 2003	Tested By:	Yujeng Wu

Antenna Polarization:Horizontal

Frequency (MHz)	Cable Loss (dB)	Antenna Factor (dB/m)	Reading Data (dBµV)	Emission Level (dBµV/m)	Limit (dBµV/m)	Margin (dB)	AZ(°)	EL(m)
54.0900	1.04	9.96	10.1	21.1	40.0	-18.9	69.1	1.76
81.1200	1.13	8.04	11.3	20.5	40.0	-19.5	124.3	1.51
108.0000	1.23	8.52	*	*	43.5	*	-	-
135.0000	1.39	8.30	*	*	43.5	*	-	-

Antenna Polarization:Vertical

Frequency (MHz)	Cable Loss (dB)	Antenna Factor (dB/m)	Reading Data (dBµV)	Emission Level (dBµV/m)	Limit (dBµV/m)	Margin (dB)	AZ(°)	EL(m)
54.0934	1.04	9.96	16.2	27.2	40.0	-12.8	297.4	1.00
81.0900	1.13	8.04	15.9	25.1	40.0	-14.9	72.3	1.00
108.0000	1.23	8.52	*	*	43.5	*	-	-
135.0000	1.39	8.30	*	*	43.5	*	-	-

NOTE :

1. Measurement uncertainty is +/-4dB.
2. "*": Measurement does not apply for this frequency.
3. Emission Level = Reading Value + Ant. Factor + Cable Loss.
4. The field strength of other emission frequencies were very low against the limit.



Temperature:	26° C	Humidity:	55 %RH
Ferquency Range:	30 – 1000 MHz	Measured Distance:	10m
Receiver Detector:	Q.P.	Tested Mode:	1 (Mouse+Receiver)
Tested Date:	Nov. 17, 2003	Tested By:	Yujeng Wu

Antenna Polarization:Horizontal

Frequency (MHz)	Cable Loss (dB)	Antenna Factor (dB/m)	Reading Data (dBμV)	Emission Level (dBμV/m)	Limit (dBμV/m)	Margin (dB)	AZ(°)	EL(m)
67.8300	1.03	8.21	12.1	21.3	40.0	-18.7	241.9	1.54
81.2400	1.13	8.04	14.6	23.8	40.0	-16.2	230.9	1.62
135.2140	1.39	8.30	13.2	22.9	43.5	-20.6	342.6	1.42
211.3900	1.68	10.94	15.6	28.2	43.5	-15.3	86.2	1.49
432.5500	2.61	16.68	13.8	33.1	46.0	-12.9	164.3	1.00
499.4800	2.94	17.99	9.6	30.5	46.0	-15.5	76.5	1.60

Antenna Polarization:Vertical

Frequency (MHz)	Cable Loss (dB)	Antenna Factor (dB/m)	Reading Data (dBμV)	Emission Level (dBμV/m)	Limit (dBμV/m)	Margin (dB)	AZ(°)	EL(m)
54.2900	1.04	9.96	11.6	22.6	40.0	-17.4	264.9	1.05
67.8300	1.03	8.21	15.9	25.1	40.0	-14.9	253.7	1.67
81.2600	1.13	8.04	12.4	21.6	40.0	-18.4	250.6	1.00
127.6800	1.36	8.23	16.8	26.4	43.5	-17.1	12.7	1.92
211.3900	1.68	10.94	14.3	26.9	43.5	-16.6	90.6	1.64
499.4800	2.94	17.99	8.2	29.1	46.0	-16.9	86.1	1.23

NOTE :

1. Measurement uncertainty is +/-4dB.
2. "**": Measurement does not apply for this frequency.
3. Emission Level = Reading Value + Ant. Factor + Cable Loss.
4. The field strength of other emission frequencies were very low against the limit.



Temperature:	<u>26° C</u>	Humidity:	<u>55 %RH</u>
Ferquency Range:	<u>30 – 1000 MHz</u>	Measured Distance:	<u>10m</u>
Receiver Detector:	<u>Q.P.</u>	Tested Mode:	<u>2 (Mouse +USB Dongle)</u>
Tested Date:	<u>Nov. 17, 2003</u>	Tested By:	<u>Yujeng Wu</u>

Antenna Polarization:Horizontal

Frequency (MHz)	Cable Loss (dB)	Antenna Factor (dB/m)	Reading Data (dBµV)	Emission Level (dBµV/m)	Limit (dBµV/m)	Margin (dB)	AZ(°)	EL(m)
67.7200	1.03	8.21	12.0	21.2	40.0	-18.8	12.6	1.56
81.3600	1.13	8.04	14.8	24.0	40.0	-16.0	252.1	1.62
108.1500	1.23	8.52	15.3	25.1	43.5	-18.4	263.1	1.72
135.6200	1.39	8.30	16.1	25.8	43.5	-17.7	321.2	1.23
197.8100	1.62	10.41	13.9	25.9	43.5	-17.6	86.9	1.24
431.5800	2.66	16.67	8.3	27.6	46.0	-18.4	56.8	1.05

Antenna Polarization:Vertical

Frequency (MHz)	Cable Loss (dB)	Antenna Factor (dB/m)	Reading Data (dBµV)	Emission Level (dBµV/m)	Limit (dBµV/m)	Margin (dB)	AZ(°)	EL(m)
67.8000	1.03	8.21	12.1	21.3	40.0	-18.7	21.3	1.00
81.5200	1.13	8.04	16.5	25.7	40.0	-14.3	242.3	1.82
108.2400	1.23	8.52	15.4	25.2	43.5	-18.3	320.7	1.06
164.8300	1.58	9.36	12.5	23.4	43.5	-20.1	120.4	1.85
432.6600	2.61	16.68	9.1	28.4	46.0	-17.6	60.8	1.61
563.5100	3.30	19.59	8.6	31.5	46.0	-14.5	69.4	1.24

NOTE :

1. Measurement uncertainty is +/-4dB.
2. "**": Measurement does not apply for this frequency.
3. Emission Level = Reading Value + Ant. Factor + Cable Loss.
4. The field strength of other emission frequencies were very low against the limit.



Temperature:	<u>26° C</u>	Humidity:	<u>55 %RH</u>
Ferquency Range:	<u>30 – 1000 MHz</u>	Measured Distance:	<u>10m</u>
Receiver Detector:	<u>Q.P.</u>	Tested Mode:	<u>3 (Mouse +USB Dongle +Transmitter cable)</u>
Tested Date:	<u>Nov. 17, 2003</u>	Tested By:	<u>Yujeng Wu</u>

Antenna Polarization:Horizontal

Frequency (MHz)	Cable Loss (dB)	Antenna Factor (dB/m)	Reading Data (dBµV)	Emission Level (dBµV/m)	Limit (dBµV/m)	Margin (dB)	AZ(°)	EL(m)
67.2100	1.03	8.21	12.1	21.3	40.0	-18.7	12.6	1.56
81.3600	1.13	8.04	14.9	24.1	40.0	-15.9	252.1	1.62
108.1500	1.23	8.52	16.8	26.6	43.5	-16.9	263.1	1.72
135.6200	1.39	8.30	16.7	26.4	43.5	-17.1	321.2	1.23
197.8100	1.62	10.41	14.2	26.2	43.5	-17.3	86.9	1.24
431.5800	2.66	16.67	9.3	28.6	46.0	-17.4	56.8	1.05

Antenna Polarization:Vertical

Frequency (MHz)	Cable Loss (dB)	Antenna Factor (dB/m)	Reading Data (dBµV)	Emission Level (dBµV/m)	Limit (dBµV/m)	Margin (dB)	AZ(°)	EL(m)
67.1900	1.03	8.21	13.2	22.4	40.0	-17.6	21.3	1.00
81.3700	1.13	8.04	17.9	27.1	40.0	-12.9	242.3	1.82
135.6300	1.39	8.30	15.3	25.0	43.5	-18.5	320.7	1.06
284.1400	1.94	13.94	12.5	28.4	46.0	-17.6	120.4	1.85
432.6200	2.61	16.68	8.3	27.6	46.0	-18.4	60.8	1.61
499.4800	2.94	17.99	9.6	30.5	46.0	-15.5	69.4	1.24

NOTE :

1. Measurement uncertainty is +/-4dB.
2. "**": Measurement does not apply for this frequency.
3. Emission Level = Reading Value + Ant. Factor + Cable Loss.
4. The field strength of other emission frequencies were very low against the limit.



6. BAND EDGE

6.1 BAND EDGE LIMIT

The limit is less than 26dB with respect to the amplitude of fundamental frequency.

6.2 TEST EQUIPMENT

The following test equipment was used during the radiated emission test:

EQUIPMENT/ FACILITIES	SPECIFICATIONS	MANUFACTURER	MODEL#/ SERIAL#	DUE DATE OF CAL. & CAL. CENTER
SPECTRUM	9 kHz TO 7GHz	ROHDE & SCHWARZ	FSP7/ 839511/010	MAR. 2004 R&S

NOTE:

The calibration interval of the above test equipment is one year and the calibrations are traceable to NML/ROC and NIST/USA.

6.3 TEST SET-UP

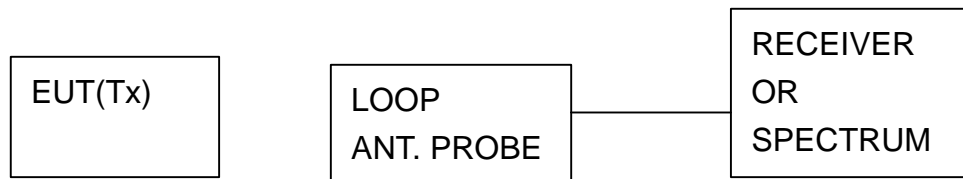

6.4 TEST PROCEDURE

A specific loop antenna was connected to receiver to detect the EUT' s power level. The Receiver displayed the EUT' s power level and printed out the plot of measurement.

6.5 EUT OPERATING CONDITION

Set the EUT under transmission condition continuously at specific channel frequency.



6.6 BAND EDGE TEST RESULT

Temperature: 25 °C Humidity: 55 %RH
 Receiver Detector: Peak Tested By: Yujeng Wu
 Test Result: Pass

FREQUENCY (MHZ)	RF LEVEL 10kHz BW (dBm)	LIMIT (dBm)	MARGIN (dB)
26.961	-33.73	-30.5	-3.23
27.129	-31.47	-30.5	-0.97

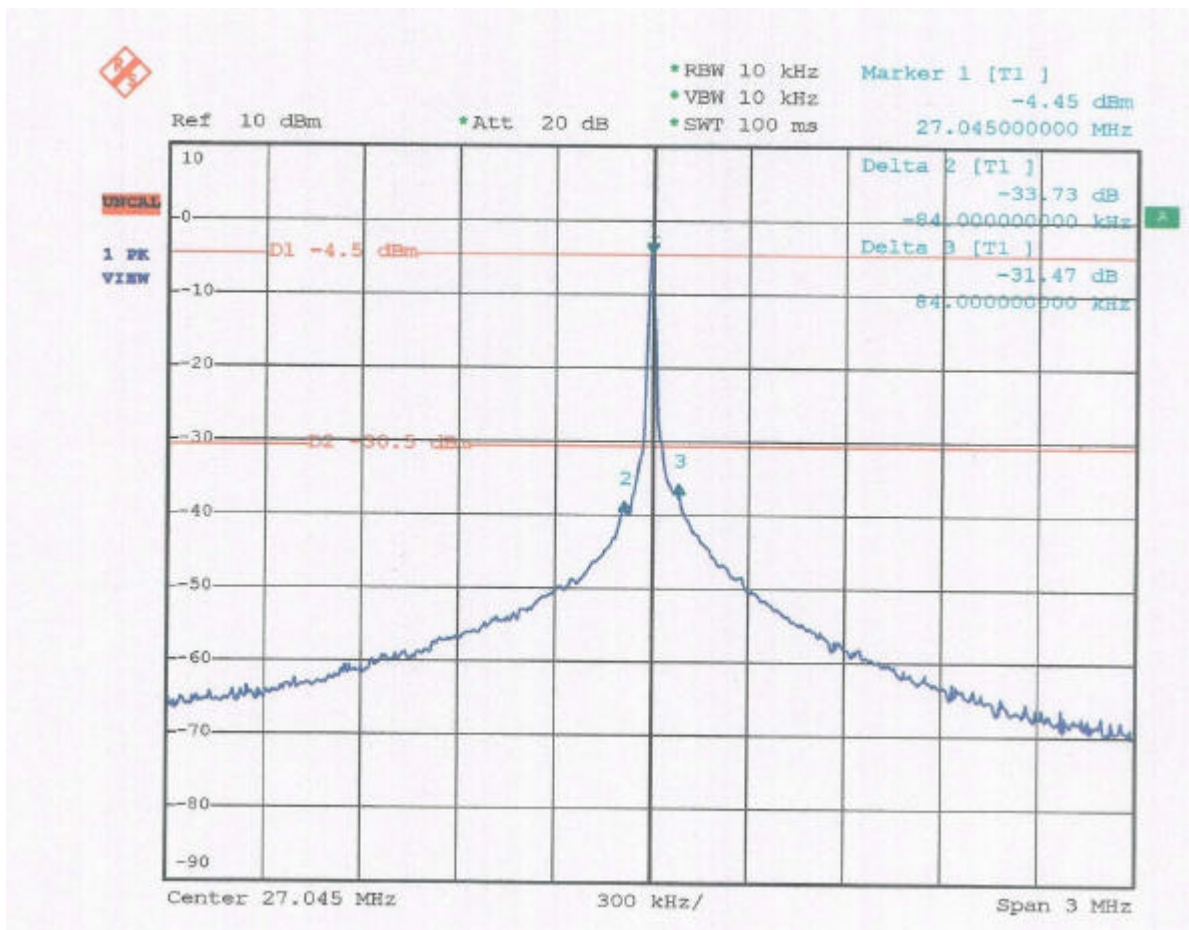



**Spectrum Research
& Testing Lab., Inc.**

No. 101-10, Ling 8,
Shan-Tong Li, Chung-Li
City, Taoyuan, Taiwan,
R.O.C.

TEST REPORT

Reference No.:A03110506

Report No.:FCCA03110506

Page:23 of 29

Date:Nov. 21, 2003

7. PHOTOS OF TESTING - Conducted test (Mode 1)

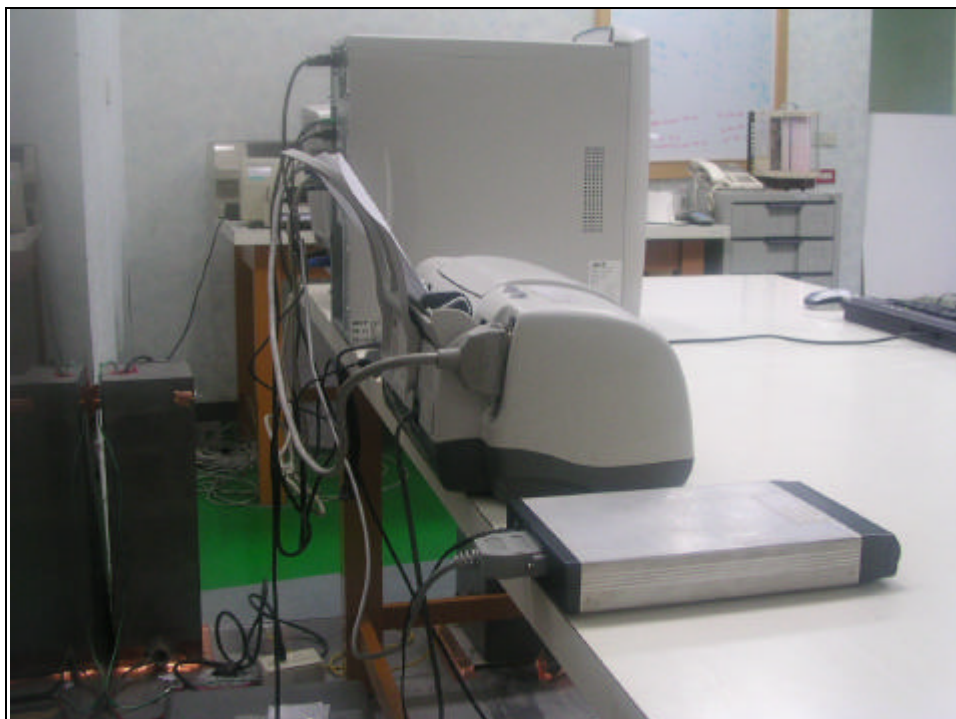



- Conducted test (Mode 2)





- Conducted test (Mode 3)

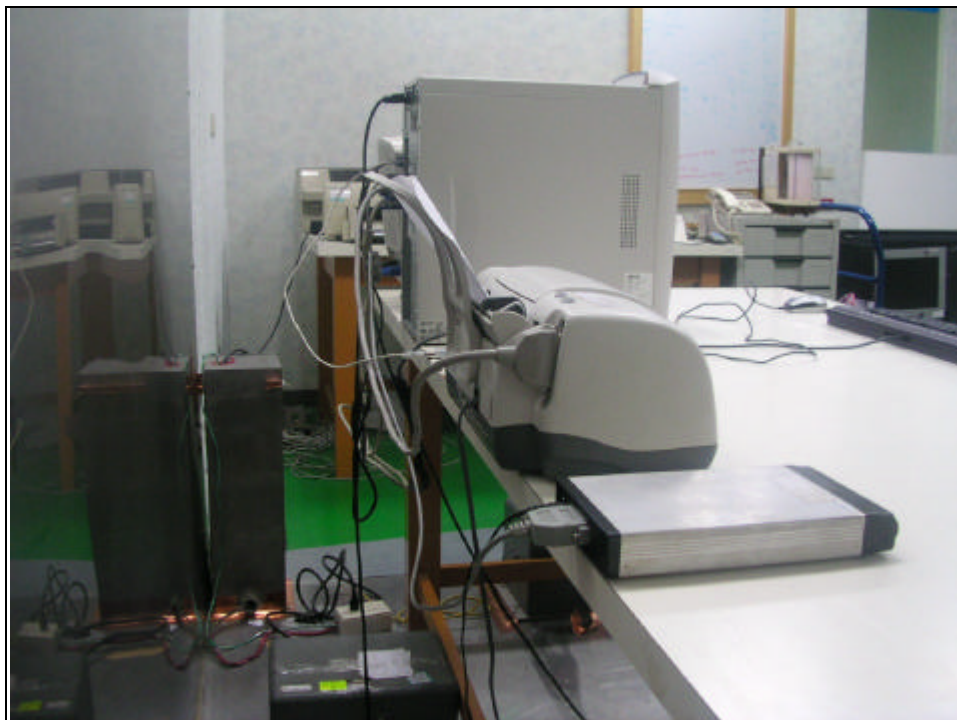



Spectrum Research & Testing Lab., Inc.

No. 101-10, Ling 8,
Shan-Tong Li, Chung-Li
City, Taoyuan, Taiwan,
R.O.C.

TEST REPORT

Reference No.:A03110506

Report No.:FCCA03110506

Page:26 of 29

Date:Nov. 21, 2003

- Radiated test (Mode 1)





- Radiated test (Mode 2)





- Radiated test (Mode 3)





**Spectrum Research
& Testing Lab., Inc.**

No. 101-10, Ling 8,
Shan-Tong Li, Chung-Li
City, Taoyuan, Taiwan,
R.O.C.

TEST REPORT

Reference No.:A03110506
Report No.:FCCA03110506
Page:29 of 29
Date:Nov. 21, 2003

8. TERMS OF ABRIVATION

AV.	Average detection
AZ(°)	Turn table azimuth
Correct.	Correction
EL(m)	Antenna height (meter)
EUT	Equipment Under Test
Horiz.	Horizontal direction
LISN	Line Impedance Stabilization Network
NSA	Normalized Site Attenuation
Q.P.	Quasi-peak detection
SRT Lab	Spectrum Research & Testing Laboratory, Inc.
Vert.	Vertical direction