



# FCC TEST REPORT

for

2.4G Wireless Presenter  
Model: APT-N5/AP01B  
Brand: Sysgration/Acer

Test Report Number:  
SZ110129B02-RP

Issued for

Sysgration Ltd.

10FL.,NO.868-3,Zhongzheng Rd., Zhonghe Dist, New Taipei City, 235  
Taiwan,R.O.C

Issued by:

**COMPLIANCE CERTIFICATION SERVICES (SHENZHEN) INC.**

No10-1, Mingkeda Logistics Park, No.18 Huanguan South RD. Guan lan Town,  
Baoan District, Shenzhen China

TEL: 86-755-28055000

FAX: 86-755-28055221

Issued Date: February 21, 2011



**Note:** This report shall not be reproduced except in full, without the written approval of Compliance Certification Services Inc. This document may be altered or revised by Compliance Certification Services Inc. personnel only, and shall be noted in the revision section of the document. The client should not use it to claim product endorsement by TAF, A2LA, NVLAP, NIST or any government agencies. The test result of this report relate only to the tested sample identified in this report.



Revision History

Rev.	Issue No.	Revisions	Effect Page	Revised By
00	SZ110129B02-RP	Initial Issue	ALL	Vincent Yao



**TABLE OF CONTENTS**

**1 TEST CERTIFICATION..... 4**

**2 EUT DESCRIPTION..... 5**

**3 TEST METHODOLOGY ..... 6**

3.1. DESCRIPTION OF TEST MODES ..... 6

**4 TEST METHODOLOGY ..... 7**

4.1. EUT EXERCISE ..... 7

4.2. FCC PART 15.205 RESTRICTED BANDS OF OPERATIONS ..... 7

**5 INSTRUMENT CALIBRATION ..... 8**

**6 SETUP OF EQUIPMENT UNDER TEST ..... 8**

6.1. DESCRIPTION OF SUPPORT UNITS..... 8

6.2. CONFIGURATION OF SYSTEM UNDER TEST ..... 8

**7 FACILITIES AND ACCREDITATIONS ..... 9**

7.1. FACILITIES ..... 9

7.2. ACCREDITATIONS ..... 9

7.3. MEASUREMENT UNCERTAINTY..... 9

**8 FCC PART 15.249 REQUIREMENTS..... 10**

8.1. BAND EDGES MEASUREMENT..... 10

8.2. POWER LINE CONDUCTED EMISSIONS MEASUREMENT ..... 16

8.3. SPURIOUS EMISSIONS MEASUREMENT..... 19



# 1 TEST CERTIFICATION

**Product:** 2.4G Wireless Presenter  
**Model:** APT-N5/AP01B  
**Brand:** Sysgration/Acer  
**Tested:** February 9~18,2011  
**Applicant:** **Sysgration Ltd.**  
 10FL.,NO.868-3,Zhongzheng Rd., Zhonghe Dist, New Taipei City, 235 Taiwan,R.O.C  
**Manufacturer:** **Sysgration(Shenzhen) Ltd.**  
 Egongling Village, Pinghu Town, Longgang Dist. Shenzhen City.China

APPLICABLE STANDARDS	
STANDARD	TEST RESULT
FCC 47 CFR Part 15 Subpart C	No non-compliance noted
DEVIATION FROM APPLICABLE STANDARD	
None	

### We hereby certify that:

The above equipment was tested by Compliance Certification Services Inc. The test data, data evaluation, test procedures, and equipment configurations shown in this report were made in accordance with the procedures given in ANSI C63.4:2003 and the energy emitted by the sample EUT tested as described in this report is in compliance with the requirements of FCC Rules Part 15.207, 15.209, 15.249.

The test results of this report relate only to the tested sample EUT identified in this report.

**Approved by:**

**Reviewed by:**

---

**Vincent Yao**  
**Manager**  
**Compliance Certification Service Inc.**

---

**Aven Zhou**  
**Supervisor of Report Dept.**  
**Compliance Certification Service Inc.**



## 2 EUT DESCRIPTION

<b>Product</b>	2.4G Wireless Presenter
<b>Trade Name</b>	APT-N5/AP01B
<b>Model Number</b>	Sysgration/Acer
<b>Model Discrepancy</b>	All models are identical to each other except for market designation for marketing purpose.
<b>Serial Number</b>	SZ110129B02-RP
<b>Power Supply</b>	DC 3V supplied by the battery
<b>Received Date</b>	February 18, 2011
<b>Frequency Range</b>	2412-2472MHz
<b>Transmit Power</b>	Peak:72.03dBuV/m (Max.) Average:23.50 dBuV/m (Max.)
<b>Modulation Technique</b>	GFSK
<b>Number of Channels</b>	5 Channels
<b>Antenna Specification</b>	PCB Antenna with 2.12dBi gain (MAX)
<b>Temperature Range</b>	0°C ~ +45°C

**Note:** 1. The sample selected for test was engineering sample that approximated to production product and was provided by manufacturer.

2. This submittal(s) (test report) is intended for FCC ID: HQXAPT-N5 filing to comply with Section 15.207, 15.209 and 15.249 of the FCC Part 15, Subpart C Rules.

3. The device would match a receiver to sale.



### 3 TEST METHODOLOGY

#### 3.1. DESCRIPTION OF TEST MODES

The EUT had been tested under operating condition.

Test program used to control the EUT for staying in continuous transmitting and receiving mode is programmed.

The following test mode(s) were scanned during the preliminary test below 1G:

Test Item	Test mode	Worse mode
Conducted Emission	Not applicable, Since EUT supplied by DC power.	
Radiated Emission	Mode 1: Normal Link	■

After verification, all tests were carried out with the worst case test modes as shown below except radiated spurious emission below 1GHz, which worst case was in normal link mode only.

Channel Low (2412MHz), Channel Mid (2452MHz) and Channel High (2472MHz) were chosen for the final testing.

The field strength of spurious radiation emission was measured in the following position: EUT stand-up position (Y mode) and lie-down position (X, Z mode) The following data show only the worst case setup.

The worst case (X axis) was reported.



### 4 TEST METHODOLOGY

The tests documented in this report were performed in accordance with ANSI C63.4:2003 and FCC CFR 15.209 and 15.249.

#### 4.1. EUT EXERCISE

The EUT was operated in the engineering mode to fix the TX frequency that was for the purpose of the measurements.

According to its specifications, the EUT must comply with the requirements of the Section 15.109 under the FCC Rules Part 15 Subpart B and Section 15.209,15.249 under the FCC Rules Part 15 Subpart C.

#### 4.2. FCC PART 15.205 RESTRICTED BANDS OF OPERATIONS

(a) Except as shown in paragraph (d) of this section, only spurious emissions are permitted in any of the frequency bands listed below:

MHz	MHz	MHz	GHz
0.090 - 0.110	16.42 - 16.423	399.9 - 410	4.5 - 5.15
<sup>1</sup> 0.495 - 0.505	16.69475 - 16.69525	608 - 614	5.35 - 5.46
2.1735 - 2.1905	16.80425 - 16.80475	960 - 1240	7.25 - 7.75
4.125 - 4.128	25.5 - 25.67	1300 - 1427	8.025 - 8.5
4.17725 - 4.17775	37.5 - 38.25	1435 - 1626.5	9.0 - 9.2
4.20725 - 4.20775	73 - 74.6	1645.5 - 1646.5	9.3 - 9.5
6.215 - 6.218	74.8 - 75.2	1660 - 1710	10.6 - 12.7
6.26775 - 6.26825	108 - 121.94	1718.8 - 1722.2	13.25 - 13.4
6.31175 - 6.31225	123 - 138	2200 - 2300	14.47 - 14.5
8.291 - 8.294	149.9 - 150.05	2310 - 2390	15.35 - 16.2
8.362 - 8.366	156.52475 -	2483.5 - 2500	17.7 - 21.4
8.37625 - 8.38675	156.52525	2655 - 2900	22.01 - 23.12
8.41425 - 8.41475	156.7 - 156.9	3260 - 3267	23.6 - 24.0
12.29 - 12.293	162.0125 - 167.17	3332 - 3339	31.2 - 31.8
12.51975 - 12.52025	167.72 - 173.2	3345.8 - 3358	36.43 - 36.5
12.57675 - 12.57725	240 - 285	3600 - 4400	( <sup>2</sup> )
13.36 - 13.41	322 - 335.4		

<sup>1</sup> Until February 1, 1999, this restricted band shall be 0.490-0.510 MHz.

<sup>2</sup> Above 38.6

(b) Except as provided in paragraphs (d) and (e), the field strength of emissions appearing within these frequency bands shall not exceed the limits shown in Section 15.209. At frequencies equal to or less than 1000 MHz, compliance with the limits in Section 15.209 shall be demonstrated using measurement instrumentation employing a CISPR quasi-peak detector. Above 1000 MHz, compliance with the emission limits in Section 15.209 shall be demonstrated based on the average value of the measured emissions. The provisions in Section 15.35 apply to these measurements.



## 5 INSTRUMENT CALIBRATION

The measuring equipment, which was utilized in performing the tests documented herein, has been calibrated in accordance with the manufacturer's recommendations for utilizing calibration equipment, which is traceable to recognized national standards.

## 6 SETUP OF EQUIPMENT UNDER TEST

### 6.1. DESCRIPTION OF SUPPORT UNITS

The EUT has been tested as an independent unit together with other necessary accessories or support units. The following support units or accessories were used to form a representative test configuration during the tests.

No.	Equipment	Model No.	Serial No.	FCC ID	Trade Name	Data Cable	Power Cord
1	N/A						

**Note:**

- 1) All the equipment/cables were placed in the worst-case configuration to maximize the emission during the test.
- 2) Grounding was established in accordance with the manufacturer's requirements and conditions for the intended use.

### 6.2. CONFIGURATION OF SYSTEM UNDER TEST

See test photographs attached in Appendix II for the actual connections between EUT and support equipment.





## 7 FACILITIES AND ACCREDITATIONS

### 7.1. FACILITIES

All measurement facilities used to collect the measurement data are located at  **No10-1, Mingkeda Logistics Park, No.18 Huanguan South RD. Guan lan Town, Baoan District, Shenzhen China**

The sites are constructed in conformance with the requirements of ANSI C63.4:2003, ANSI C63.7 and CISPR Publication 22. All receiving equipment conforms to CISPR Publication 16-1, "Radio Interference Measuring Apparatus and Measurement Methods."

### 7.2. ACCREDITATIONS

Our laboratories are accredited and approved by the following accreditation body according to ISO/IEC 17025.

<b>USA</b>	<b>A2LA</b>
<b>China</b>	<b>CNAS</b>

The measuring facility of laboratories has been authorized or registered by the following approval agencies.

<b>USA</b>	<b>FCC</b>
<b>Japan</b>	<b>VCCI</b>
<b>Canada</b>	<b>INDUSTRY CANADA</b>
<b>Taiwan</b>	<b>BSMI</b>
<b>Norway</b>	<b>Nemko</b>

Copies of granted accreditation certificates are available for downloading from our web site, <http://www.ccsrf.com>

### 7.3. MEASUREMENT UNCERTAINTY

Where relevant, the following measurement uncertainty levels have been estimated for tests performed on the EUT as specified in CISPR 16-4-2:

Measurement	Frequency	Uncertainty
Conducted emissions	9kHz~30MHz	+/- 3.18dB
Radiated emissions	30MHz ~ 200MHz	+/- 3.79dB
	200MHz ~1000MHz	+/- 3.62dB
	Above 1000MHz	+/- 5.04dB

This uncertainty represents an expanded uncertainty expressed at approximately the 95% confidence level using a coverage factor of k=2.

The measured result is above (below) the specification limit by a margin less than the measurement uncertainty; it is therefore not possible to state compliance based on the 95% level of confidence. However, the result indicates that compliance (non-compliance) is more probable than non-compliance) with the specification limit.



### 8 FCC PART 15.249 REQUIREMENTS

#### 8.1. BAND EDGES MEASUREMENT

##### LIMIT

1. In the above emission table, the tighter limit applies at the band edges.

Frequency (Hz)	Field Strength (µV/m at 3-meter)	Field Strength (dBµV/m at 3-meter)
30-88	100	40
88-216	150	43.5
216-960	200	46
Above 960	500	54

- 2. As shown in Section 15.35(b), for frequencies above 1000 MHz, the above field strength limits in paragraphs (a) and (b) of this section are based on average limits. However, the peak field strength of any emission shall not exceed the maximum permitted average limits specified above by more than 20 dB under any condition of modulation. For point-to-point operation under paragraph (b) of this section, the peak field strength shall not exceed 2500 millivolts/meter at 3 meters along the antenna azimuth.
- 3. As shown in Section 15.249(d) Emissions radiated outside of the specified frequency bands, except for harmonics, shall be attenuated by at least 50 dB below the level of the fundamental or to the general radiated emission limits in Section 15.209, whichever is the lesser attenuation.

#### MEASUREMENT EQUIPMENT USED

Radiated Emission Test Site 966 (2)						
Name of Equipment	Manufacturer	Model Number	Serial Number	Last Calibration	Due Calibration	
PSA Series Spectrum Analyzer	Agilent	E4446A	US44300399	03/21/2010	03/21/2011	
Amplifier	MITEQ	AM-1604-3000	1411843	03/21/2010	03/21/2011	
Turn Table	EMCO	2081-1.21	N/A	N.C.R	N.C.R	
Controller	CT	N/A	N/A	N.C.R	N.C.R	
High Noise Amplifier	Agilent	8449B	3008A01838	06/18/2010	06/18/2011	
Site NSA	C&C	N/A	N/A	N.C.R	N.C.R	
Bilog Antenna	SCHAFFNER	CBL6143	5082	06/18/2010	06/18/2011	
Horn Antenna	SCHWARZBECK	BBHA9120D	D286	03/19/2010	03/19/2011	
Signal Generator	Anritsu	MG3694A	#050125	03/21/2010	03/21/2011	
Horn Antenna	TRC	HA0301	N/A	03/19/2010	03/19/2011	
Loop Antenna	A.R.A	PLA-1030/B	1029	03/19/2010	03/19/2011	
Power Sensor	Anritsu	MA2491A	030619	06/18/2010	06/18/2011	
Power Meter	Anritsu	ML2487A	6K00001491	06/18/2010	06/18/2011	
Temp. / Humidity Meter	VICTOR	VC230	N/A	03/30/2010	03/30/2011	

Remark: Each piece of equipment is scheduled for calibration once a year.



## Test Configuration

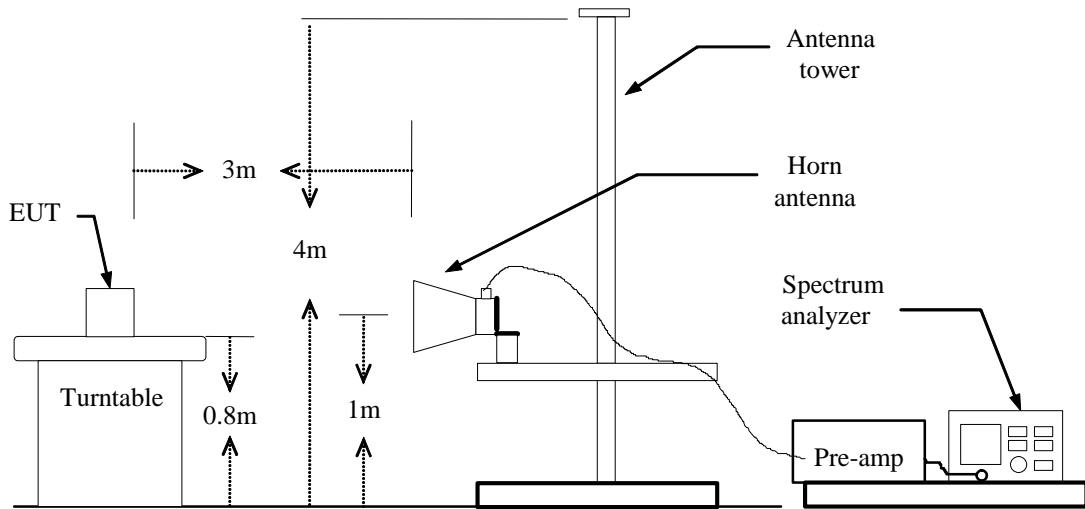

## TEST PROCEDURE

1. The EUT is placed on a turntable, which is 0.8m above the ground plane.
2. The turntable shall be rotated for 360 degrees to determine the position of maximum emission level.
3. EUT is set 3m away from the receiving antenna, which is varied from 1m to 4m to find out the highest emission.
4. Set the spectrum analyzer in the following setting in order to capture the lower and upper band-edges of the emission:
  - (a) PEAK: RBW=VBW=1MHz / Sweep=AUTO
  - (b) AVERAGE: RBW=1MHz / VBW=10Hz / Sweep=AUTO
5. Repeat the procedures until all the PEAK and AVERAGE versus POLARIZATION are measured.

## TEST RESULTS

*Refer to attach spectrum analyzer data chart.*



Test Data

Band Edges (CH-Low)

Detector mode: Peak

Polarity: Vertical

Agilent 15:49:11 Feb 18, 2011

R T

Mkr1 2.411 9 GHz  
79.52 dBµV

Ref 96.99 dBµV #Atten 0 dB

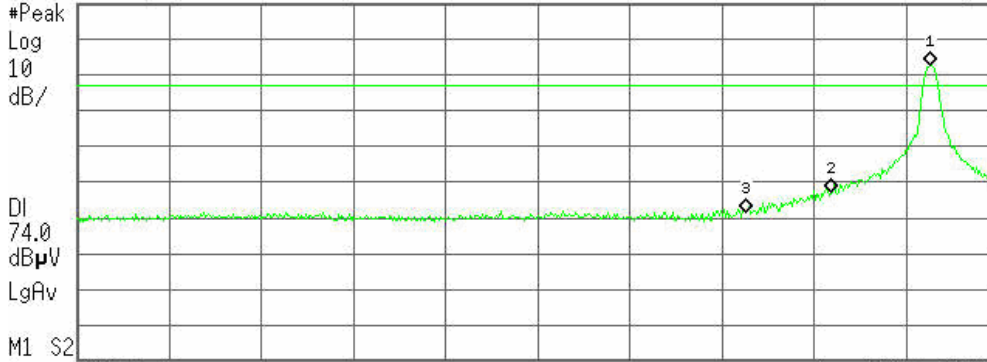

Start 2.310 0 GHz Stop 2.420 0 GHz  
#Res BW 1 MHz #VBW 1 MHz Sweep 1 ms (601 pts)

Marker	Trace	Type	X Axis	Amplitude
1	(1)	Freq	2.411 9 GHz	79.52 dBµV
2	(1)	Freq	2.400 0 GHz	44.27 dBµV
3	(1)	Freq	2.390 0 GHz	38.72 dBµV

Detector mode: Average

Polarity: Vertical

Agilent 15:49:44 Feb 18, 2011

R T

Mkr1 2.411 9 GHz  
32.44 dBµV

Ref 96.99 dBµV #Atten 0 dB

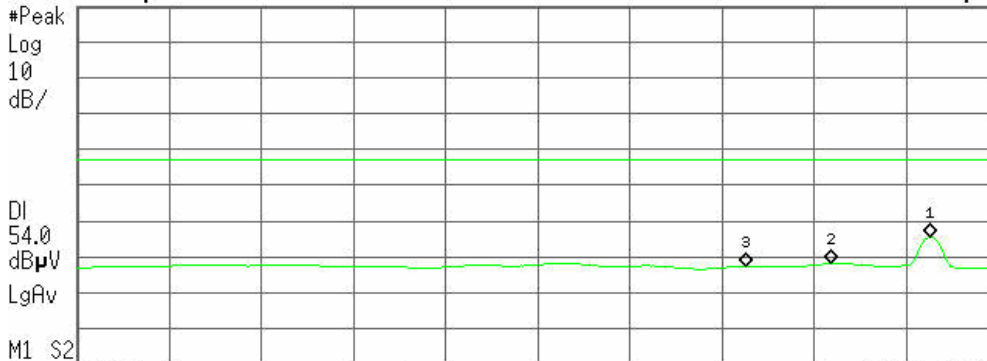

Start 2.310 0 GHz Stop 2.420 0 GHz  
#Res BW 1 MHz #VBW 10 Hz Sweep 8.577 s (601 pts)

Marker	Trace	Type	X Axis	Amplitude
1	(1)	Freq	2.411 9 GHz	32.44 dBµV
2	(1)	Freq	2.400 0 GHz	25.01 dBµV
3	(1)	Freq	2.390 0 GHz	24.35 dBµV



Detector mode: Peak

Polarity: Horizontal

Agilent 15:54:05 Feb 18, 2011

R T

Mkr1 2.411 9 GHz  
79.17 dBμV

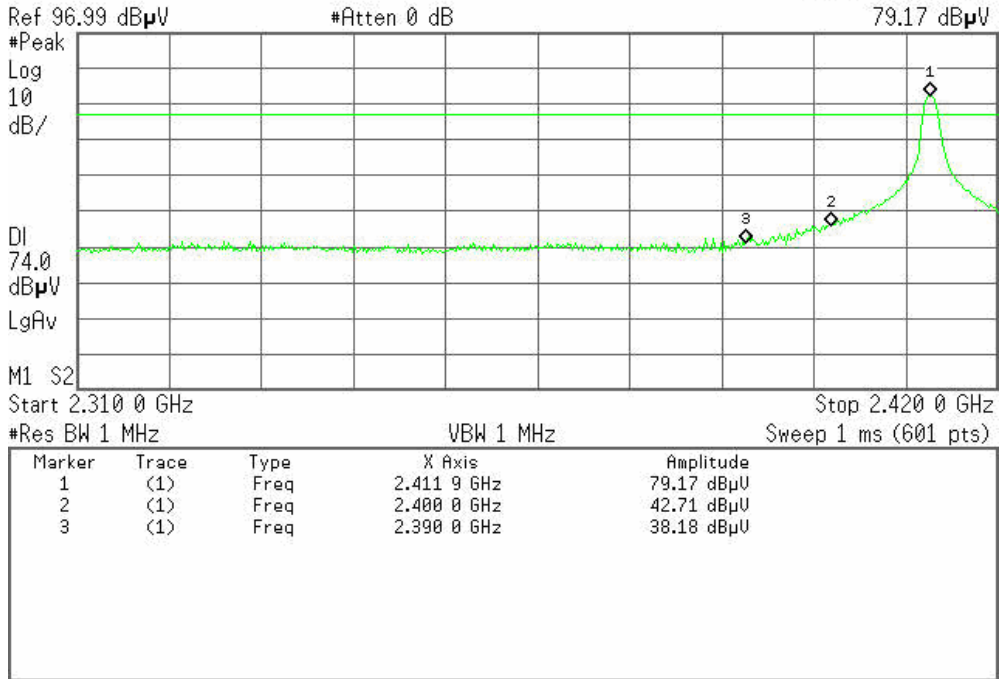

Detector mode: Average

Polarity: Horizontal

Agilent 15:54:40 Feb 18, 2011

R T

Mkr1 2.411 9 GHz  
32.62 dBμV

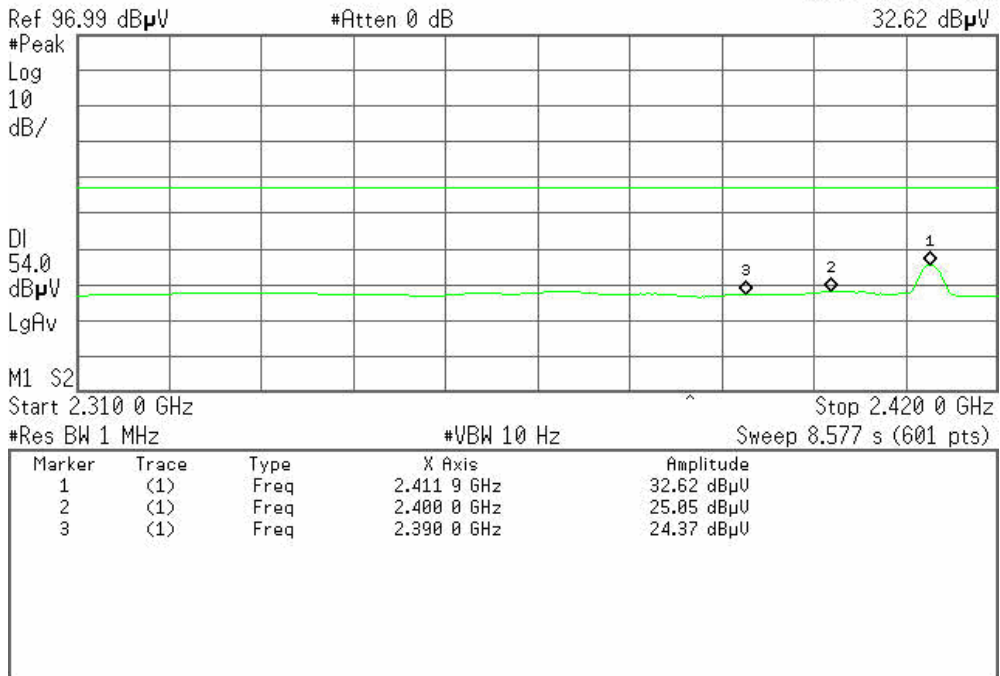



Band Edges (CH-High)

Detector mode: Peak

Polarity: Vertical

Agilent 16:03:54 Feb 18, 2011

R T

Mkr1 2.471 95 GHz  
83.05 dBµV

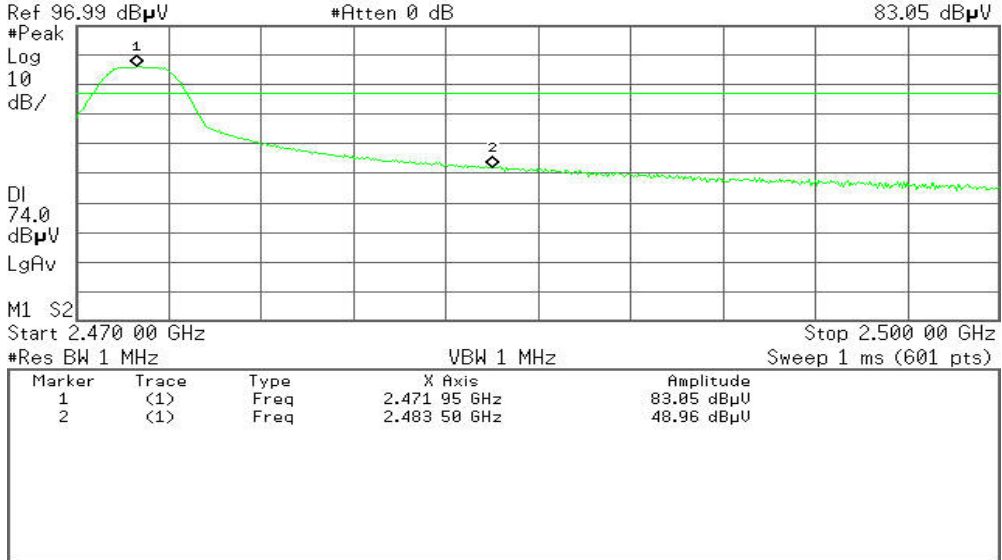

Detector mode: Average

Polarity: Vertical

Agilent 16:04:23 Feb 18, 2011

R T

Mkr1 2.472 05 GHz  
33.27 dBµV

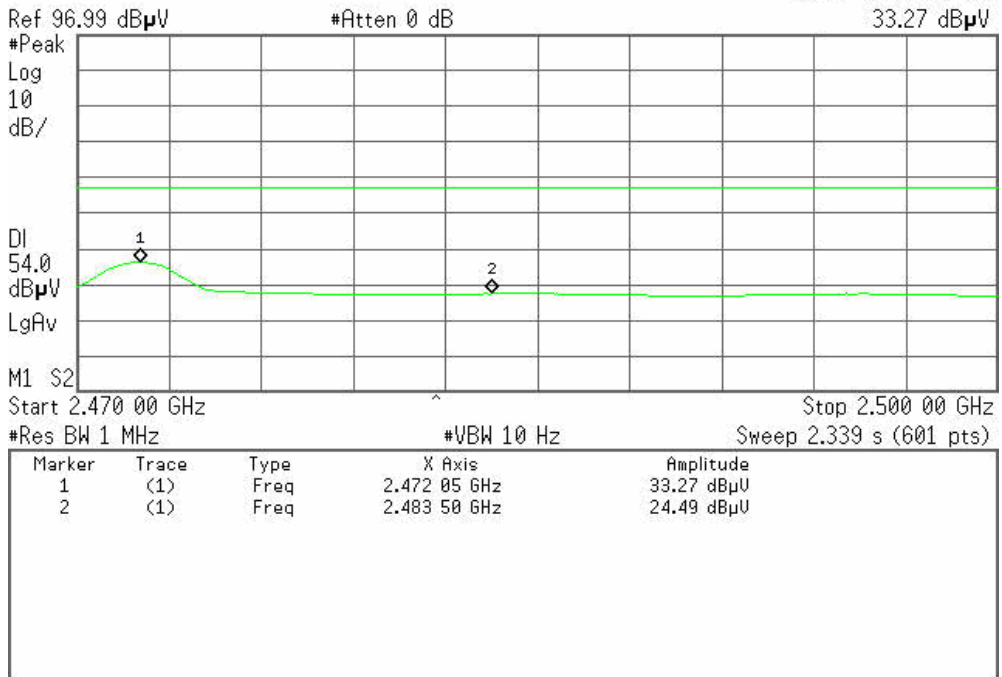



Detector mode: Peak

Polarity: Horizontal

Agilent 16:00:22 Feb 18, 2011

R T

Mkr1 2.471 95 GHz  
81.80 dBµV

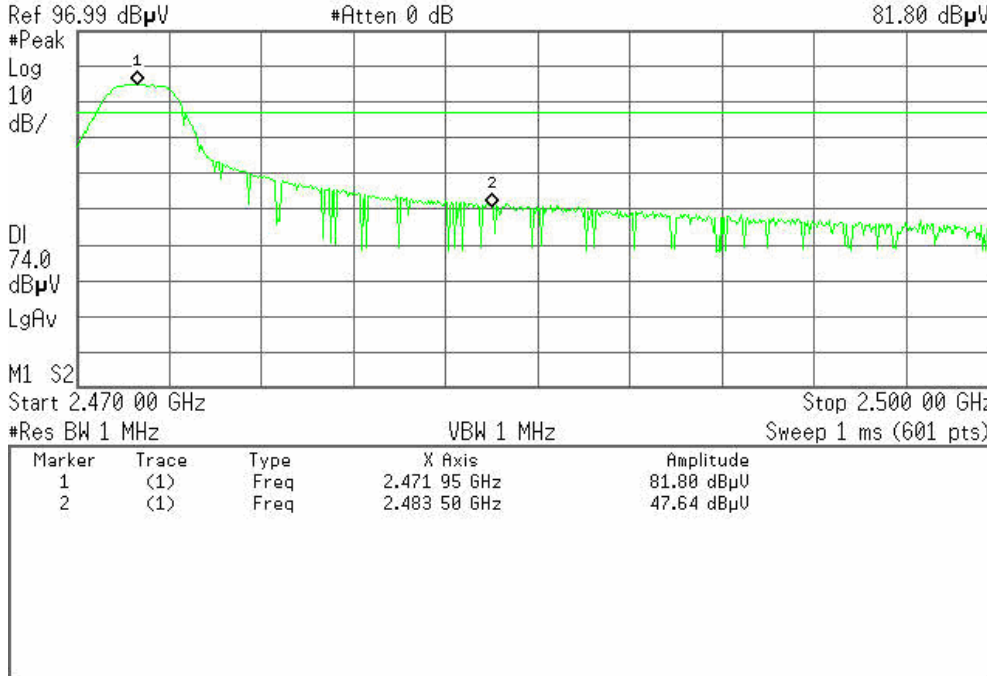

Detector mode: Average

Polarity: Horizontal

Agilent 16:01:04 Feb 18, 2011

R T

Mkr1 2.472 10 GHz  
33.08 dBµV

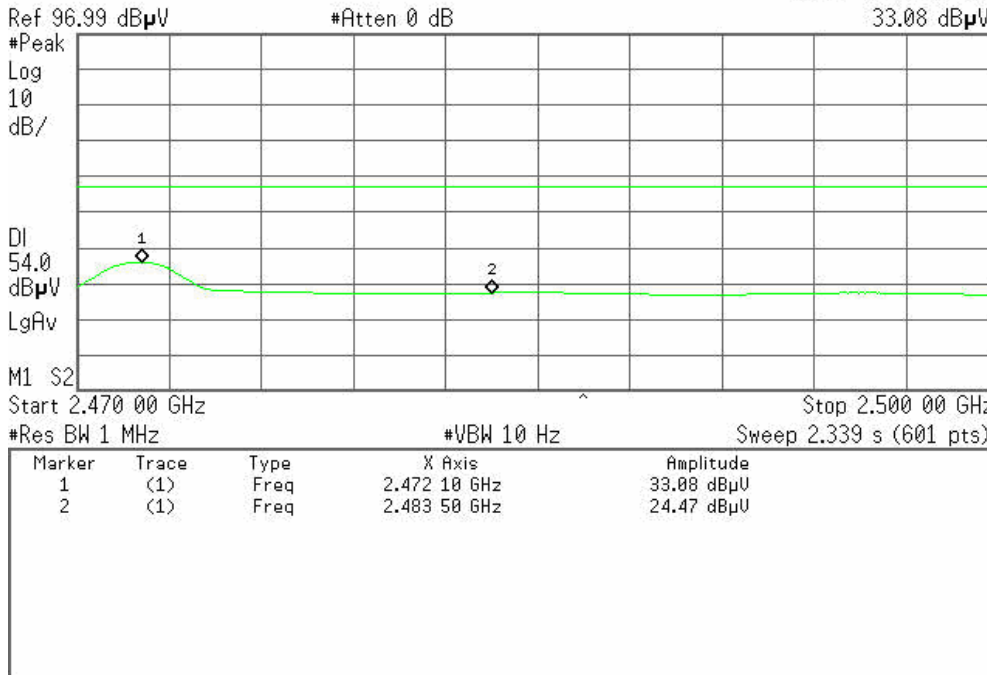



### 8.2. POWER LINE CONDUCTED EMISSIONS MEASUREMENT

#### 8.2.1. LIMITS OF CONDUCTED EMISSIONS MEASUREMENT

According to §15.207(a), except as shown in paragraphs (b) and (c) of this section, for an intentional radiator that is designed to be connected to the public utility (AC) power line, the radio frequency voltage that is conducted back onto the AC power line on any frequency or frequencies within the band 150 kHz to 30 MHz shall not exceed the limits in the following table, as measured using a 50 μH/50 ohms line impedance stabilization network (LISN). Compliance with the provisions of this paragraph shall be based on the measurement of the radio frequency voltage between each power line and ground at the power terminal. The lower limit applies at the boundary between the frequency ranges.

Frequency Range (MHz)	Limits (dBμV)	
	Quasi-peak	Average
0.15 to 0.50	66 to 56*	56 to 46*
0.50 to 5	56	46
5 to 30	60	50

**NOTE:**

- (1) The lower limit shall apply at the transition frequencies.
- (2) The limit decreases in line with the logarithm of the frequency in the range of 0.15 to 0.50 MHz.
- (3) All emanations from a class A/B digital device or system, including any network of conductors and apparatus connected thereto, shall not exceed the level of field strengths specified above.

#### 8.2.2. TEST INSTRUMENTS

Conducted Emission Test Site					
Name of Equipment	Manufacturer	Model Number	Serial Number	Last Calibration	Due Calibration
ESCI EMI TEST RECEIVE.ESCI	ROHDE&SCHWARZ	ESCI	100783	03/21/2010	03/21/2011
Attenuator	SCHAFFNER	CFL9206	1711	07/14/2010	07/14/2011
LISN	SCHAFFNER	NNB42	2001/001	05/26/2010	05/26/2011
LISN	EMCO	3825/2	8901-1459	03/21/2010	03/21/2011
Current Probe	STODDART AIRCRAFT	91550-1	345-73	03/21/2010	03/21/2011
Temp. / Humidity Meter	VICTOR	VC230	N/A	03/30/2010	03/30/2011

- NOTE:** 1. The calibration interval of the above test instruments is 12 months and the calibrations are traceable to NML/ROC and NIST/USA.  
 2. N.C.R = No Calibration Request.





## 8.2.3. TEST PROCEDURES (please refer to measurement standard)

- The EUT and Support equipment, if needed, was placed on a non-conducted table, which is 0.8m above the ground plane and 0.4m away from the conducted wall.
- The test equipment EUT installed received AC main power, through a Line Impedance Stabilization Network (LISN), which supplied power source and was grounded to the ground plane. All support equipment power received from a second LISN. The two LISNs provide 50 ohm/ 50uH of coupling impedance for the measuring instrument.
- The EUT test program was started. Emissions were measured on each current carrying line of the EUT using an EMI Test Receiver connected to the LISN powering the EUT.
- The frequency range from 150 kHz to 30 MHz was searched. The test data of the worst-case condition(s) was recorded. Emission levels under limit 20dB were not recorded.



**8.2.4. TEST SETUP**

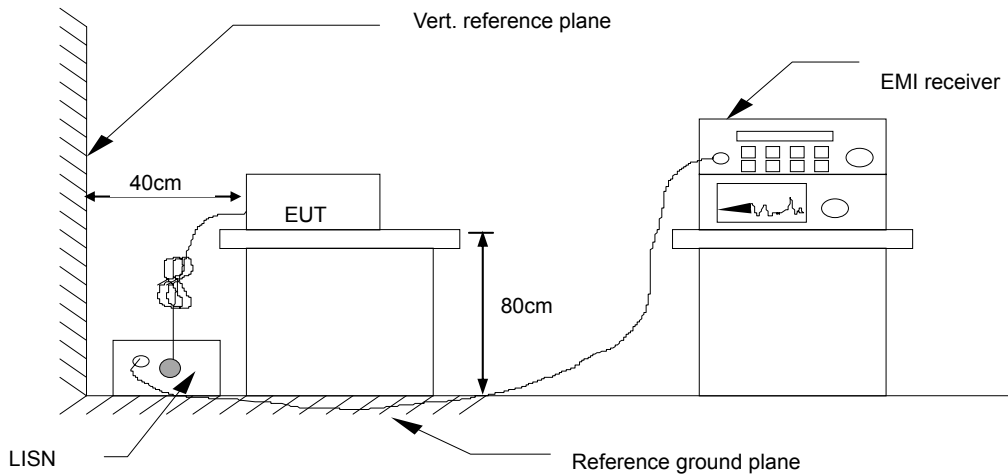

- For the actual test configuration, please refer to the related item – Photographs of the Test Configuration.

**8.2.5. Data Sample:**

Freq. (MHz)	Q.P. Level (dBuV)	AVG Level (dBuV)	Cor. Factor (dB)	Q.P. Result (dBuV)	AVG Result (dBuV)	Q.P. Limit (dBuV)	AVG Limit (dBuV)	Q.P. Margin (dB)	AVG Margin (dB)	Line (L1/L2)
xx.xx	37.86	32.92	11.52	49.38	44.44	60.41	50.41	-11.03	-5.97	L1

- Freq. = Emission frequency in MHz
- Level = Uncorrected Analyzer/Receiver reading
- Factor = Insertion loss of LISN + Cable Loss
- Result = Level+ Factor
- Limit = Limit stated in standard
- Margin = Reading in reference to limit
- P = Peak Reading
- Q.P = Quasi-peak Reading
- AVG = Average Reading
- L1 = Hot side
- L2 = Neutral side

**Calculation Formula**

Margin (dB) = Result (dBuV) – Limit (dBuV)

**8.2.6. TEST RESULTS**

***Not applicable, Since EUT supplied by the battery.***



8.3. SPURIOUS EMISSIONS MEASUREMENT

8.3.1. LIMITS OF RADIATED EMISSIONS MEASUREMENT

1. In the section 15.249(a):

Except as provided in paragraph (b) of this section, the field strength of emissions from intentional radiators operated within these frequency bands shall comply with the following:

Fundamental Frequency	Field Strength of Fundamental Field Strength (mV/m)	Field Strength of Harmonics (µV/m)
902-928 MHz	50	500
2400 - 2483.5 MHz	50	500
5725 - 5875 MHz	50	500
24.0 - 24.25 GHz	250	2500

2. Except as provided elsewhere in this Subpart, the emissions from an intentional radiator shall not exceed the field strength levels specified in the following table:

Frequency (MHz)	Field Strength (µV/m)	Measurement Distance (m)
0.009-0.490	2400/F(kHz)	300
0.490-1.705	24000/F(kHz)	30
1.705-30.0	30	30
30-88	100*	3
88-216	150*	3
216-960	200*	3
Above 960	500	3

Remark: Except as provided in paragraph (g), fundamental emissions from intentional radiators operating under this Section shall not be located in the frequency bands 54-72 MHz, 76-88 MHz, 174-216 MHz or 470-806 MHz. However, operation within these frequency bands is permitted under other sections of this Part, e.g., Sections 15.231 and 15.241.

3. In the above emission table, the tighter limit applies at the band edges.

Frequency (Hz)	Field Strength (µV/m at 3-meter)	Field Strength (dBµV/m at 3-meter)
30-88	100	40
88-216	150	43.5
216-960	200	46
Above 960	500	54



8.3.2. TEST INSTRUMENTS

Radiated Emission Test Site 966 (2)					
Name of Equipment	Manufacturer	Model Number	Serial Number	Last Calibration	Due Calibration
PSA Series Spectrum Analyzer	Agilent	E4446A	US44300399	03/21/2010	03/21/2011
Amplifier	MITEQ	AM-1604-3000	1411843	03/21/2010	03/21/2011
Turn Table	EMCO	2081-1.21	N/A	N.C.R	N.C.R
Controller	CT	N/A	N/A	N.C.R	N.C.R
High Noise Amplifier	Agilent	8449B	3008A01838	06/18/2010	06/18/2011
Site NSA	C&C	N/A	N/A	N.C.R	N.C.R
Bilog Antenna	SCHAFFNER	CBL6143	5082	06/18/2010	06/18/2011
Horn Antenna	SCHWARZBECK	BBHA9120D	D286	03/19/2010	03/19/2011
Signal Generator	Anritsu	MG3694A	#050125	03/21/2010	03/21/2011
Horn Antenna	TRC	HA0301	N/A	03/19/2010	03/19/2011
Loop Antenna	A.R.A	PLA-1030/B	1029	03/19/2010	03/19/2011
Power Sensor	Anritsu	MA2491A	030619	06/18/2010	06/18/2011
Power Meter	Anritsu	ML2487A	6K00001491	06/18/2010	06/18/2011
Temp. / Humidity Meter	VICTOR	VC230	N/A	03/30/2010	03/30/2011

- NOTE:** 1. The calibration interval of the above test instruments is 12 months and the calibrations are traceable to NML/ROC and NIST/USA.  
 2. The FCC Site Registration number is 101879.  
 4. N.C.R = No Calibration Required.

8.3.3 TEST PROCEDURE (please refer to measurement standard)

- The EUT is placed on a turntable, which is 0.8m above ground plane.
- The turntable shall be rotated for 360 degrees to determine the position of maximum emission level.
- EUT is set 3m away from the receiving antenna, which is varied from 1m to 4m to find out the highest emissions.
- Maximum procedure was performed on the six highest emissions to ensure EUT compliance.
- And also, each emission was to be maximized by changing the polarization of receiving antenna both horizontal and vertical.
- Set the spectrum analyzer in the following setting as:  
 Below 1GHz:  
     RBW=100kHz / VBW=300kHz / Sweep=AUTO  
 Above 1GHz:  
     (a) PEAK: RBW=VBW=1MHz / Sweep=AUTO  
     (b) AVERAGE: RBW=1MHz / VBW=10Hz / Sweep=AUTO
- Repeat above procedures until the measurements for all frequencies are complete.



8.3.2.1. TEST SETUP

Below 30MHz

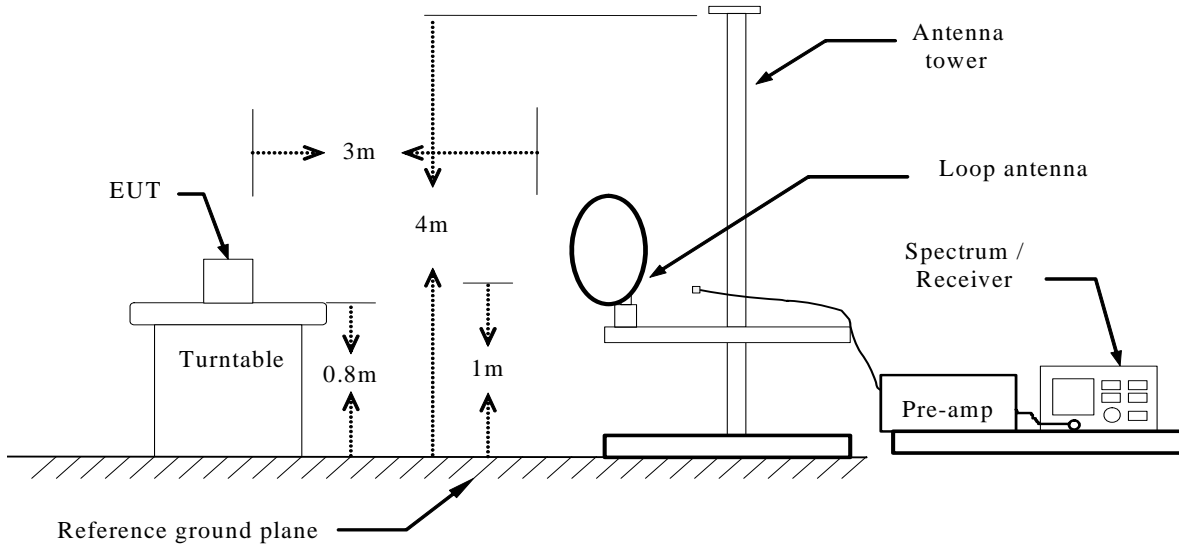

Below 1 GHz

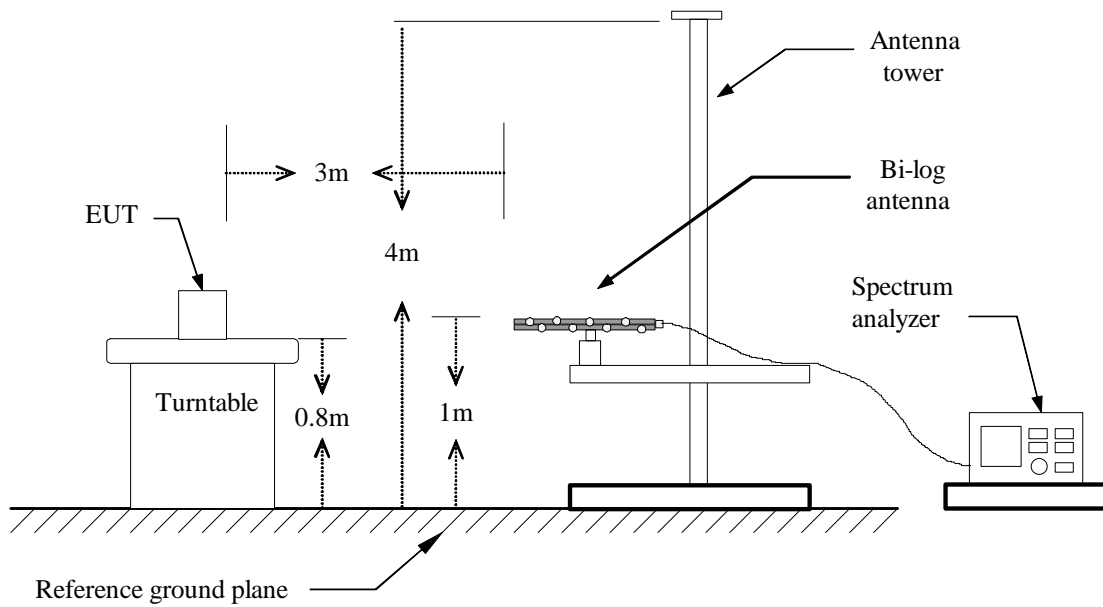



**Above 1 GHz**

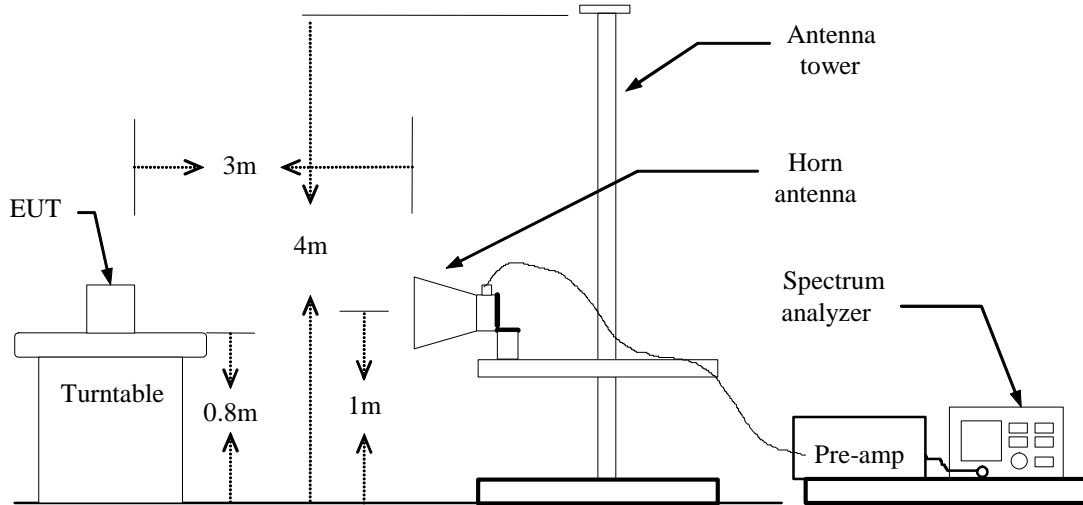

For the actual test configuration, please refer to the related item – Photographs of the Test Configuration.

**8.3.2.2. Data Sample:**

**Below 1 GHz**

Frequency (MHz)	Ant.Pol. (H/V)	Reading (Remark) (dBuV)	Correction Factor (dB/m)	Result (Remark) (dBuV/m)	Limit (Peak) (dBuV/m)	Margin (dB)	Remark
xxx	V	12.12	10.21	22.33	40.00	-17.67	Peak

**Above 1 GHz**

Frequency (MHz)	Ant.Pol. (H/V)	Reading (Peak) (dBuV)	Reading (Average) (dBuV)	Correction Factor (dB/m)	Result (Peak) (dBuV/m)	Result (Average) (dBuV/m)	Limit (Peak) (dBuV/m)	Limit (Average) (dBuV/m)	Margin (dB)	Remark
xxx	V	65.45	63.00	-11.12	54.33	51.88	74.00	54.00	-2.12	AVG

- Frequency (MHz) = Emission frequency in MHz
- Ant.Pol. (H/V) = Antenna polarization
- Reading (dBuV) = Uncorrected Analyzer / Receiver reading
- Correction Factor (dB/m) = Antenna factor + Cable loss – Amplifier gain
- Result (dBuV/m) = Reading (dBuV) + Correction Factor (dB/m)
- Limit (dBuV/m) = Limit stated in standard
- Margin (dB) = Remark Result (dBuV/m) – Limit (dBuV/m)
- Peak = Peak Reading
- QP = Quasi-peak Reading
- AVG = Average Reading



8.3.2.3. TEST RESULTS

Below 1 GHz

Operation Mode: Normal Link

Test Date: February 18, 2011

Temperature: 24°C

Tested by: Sunday Hu

Humidity: 52 % RH

Polarity: Ver. / Hor.

Freq. (MHz)	Ant.Pol. H/V	Detector Mode (PK/QP)	Reading (dBuV)	Factor (dB)	Actual FS (dBuV/m)	Limit 3m (dBuV/m)	Safe Margin (dB)
112.450	V	Peak	50.46	-20.83	29.63	43.50	-13.87
257.950	V	Peak	48.14	-19.90	28.24	46.00	-17.76
332.316	V	Peak	50.11	-17.70	32.41	40.00	-7.59
429.316	V	Peak	46.80	-15.14	31.66	43.50	-11.84
558.650	V	Peak	43.25	-12.68	30.57	46.00	-15.43
789.833	V	Peak	41.68	-10.28	31.40	46.00	-14.60
128.616	H	Peak	52.21	-20.39	31.82	43.50	-11.68
185.200	H	Peak	54.27	-22.02	32.25	43.50	-11.25
322.616	H	Peak	48.47	-17.86	30.61	40.00	-9.39
450.333	H	Peak	44.03	-14.84	29.19	43.50	-14.31
784.983	H	Peak	40.49	-10.24	30.25	46.00	-15.75
865.816	H	Peak	38.31	-9.36	28.95	46.00	-17.05

\*\*Remark: No emission found between lowest internal used/generated frequency to 30MHz.

Notes:

1. Measuring frequencies from 9kHz to the 1GHz.
2. Radiated emissions measured in frequency range from 30MHz to 1GHz were made with an instrument using Peak/Quasi-peak detector mode.
3. Data of measurement within this frequency range shown " --- " in the table above means the reading of emissions are attenuated more than 20dB below the permissible limits or the field strength is too small to be measured.
4. The IF bandwidth of SPA between 30MHz to 1GHz was 100kHz.
5. Freq(MHz) = Emission frequency in MHz  
 Reading (dBuV/m) = Receiver reading  
 Corr. Factor (dB) = Antenna factor + Cable loss – Amplifier gain  
 Actual FS (dBuV/m) = Reading (dBuV) + Corr. Factor (dB/m)  
 Limit (dBuV/m) = Limit stated in standard  
 Safe Margin(dB) = Measured (dBuV/m) – Limits (dBuV/m)  
 Ant. H/V = Current carrying line of reading  
 Detector = Mark Peak Reading or Quasi-peak Reading



Above 1 GHz

Operation Mode: TX / CH Low

Test Date: February 18, 2011

Temperature: 24°C

Tested by: Sunday Hu

Humidity: 52 % RH

Polarity: Ver. / Hor.

Fundamental

Table with 11 columns: Freq. (MHz), Ant. Pol H/V, Peak Reading (dBuV), AV Reading (dBuV), Ant. / CL CF (dB), Actual Fs (Peak and AV in dBuV/m), Peak Limit (dBuV/m), AV Limit (dBuV/m), Peak Margin (dB), AV Margin (dB). Rows show data for frequencies 2412 MHz with V and H polarizations.

Table with 11 columns: Freq. (MHz), Ant. Pol H/V, Peak Reading (dBuV), AV Reading (dBuV), Ant. / CL CF (dB), Actual Fs (Peak and AV in dBuV/m), Peak Limit (dBuV/m), AV Limit (dBuV/m), Margin (dB), Remark. Rows show various frequencies from 3227.65 MHz to 7229.89 MHz with remarks like 'Peak' or 'AVG'.

REMARKS:

- 1. Measuring frequencies from 1 GHz to the 10th harmonic of highest fundamental frequency.
2. Radiated emissions measured in frequency above 1000MHz were made with an instrument using peak/average detector mode.
3. Average test would be performed if the peak result were greater than the average limit or as required by the applicant.
4. Data of measurement within this frequency range shown " --- " in the table above means the reading of emissions are attenuated more than 20dB below the permissible limits or the field strength is too small to be measured.
5. Measurements above show only up to 6 maximum emissions noted, or would be lesser, with " N/A " remark, if no specific emissions from the EUT are recorded (ie: margin>20dB from the applicable limit) and considered that's already beyond the background noise floor.
6. Margin (dB) = Remark result (dBuV/m) – Average limit (dBuV/m).



**Operation Mode:** TX / CH Mid**Test Date:** February 18, 2011**Temperature:** 24°C**Tested by:** Sunday Hu**Humidity:** 52 % RH**Polarity:** Ver. / Hor.

### Fundamental

Freq. (MHz)	Ant. Pol H/V	Peak Reading (dBuV)	AV Reading (dBuV)	Ant. / CL CF (dB)	Actual Fs		Peak Limit (dBuV/m)	AV Limit (dBuV/m)	Peak Margin (dB)	AV Margin (dB)
					Peak (dBuV/m)	AV (dBuV/m)				
2452	V	78.65	31.40	-9.76	68.89	21.64	114	94	-45.11	-72.36
2452	H	80.10	32.90	-9.76	70.34	23.14	114	94	-43.66	-70.86

Freq. (MHz)	Ant. Pol H/V	Peak Reading (dBuV)	AV Reading (dBuV)	Ant. / CL CF (dB)	Actual Fs		Peak Limit (dBuV/m)	AV Limit (dBuV/m)	Margin (dB)	Remark
					Peak (dBuV/m)	AV (dBuV/m)				
3916.08	V	45.98	---	-3.70	42.28	---	74.00	54.00	-11.72	Peak
4814.54	V	45.53	---	-0.60	44.93	---	74.00	54.00	-9.07	Peak
4907.89	V	47.16	---	-0.30	46.86	---	74.00	54.00	-7.14	Peak
6261.42	V	44.96	---	3.78	48.74	---	74.00	54.00	-5.26	Peak
6798.16	V	45.12	---	4.30	49.42	---	74.00	54.00	-4.58	Peak
7113.21	V	44.48	---	4.72	49.20	---	74.00	54.00	-4.80	Peak
3426.01	H	47.31	---	-4.90	42.41	---	74.00	54.00	-11.59	Peak
3752.73	H	46.10	---	-3.86	42.24	---	74.00	54.00	-11.76	Peak
4907.89	H	50.04	---	-0.30	49.74	---	74.00	54.00	-4.26	Peak
5771.35	H	44.98	---	2.43	47.41	---	74.00	54.00	-6.59	Peak
6716.48	H	45.24	---	4.25	49.49	---	74.00	54.00	-4.51	Peak
7731.63	H	45.48	---	5.96	51.44	---	74.00	54.00	-2.56	Peak

**REMARKS:**

1. Measuring frequencies from 1 GHz to the 10th harmonic of highest fundamental frequency.
2. Radiated emissions measured in frequency above 1000MHz were made with an instrument using peak/average detector mode.
3. Average test would be performed if the peak result were greater than the average limit or as required by the applicant.
4. Data of measurement within this frequency range shown " --- " in the table above means the reading of emissions are attenuated more than 20dB below the permissible limits or the field strength is too small to be measured.
5. Measurements above show only up to 6 maximum emissions noted, or would be lesser, with " N/A " remark, if no specific emissions from the EUT are recorded (ie: margin>20dB from the applicable limit) and considered that's already beyond the background noise floor.
6. Margin (dB) = Remark result (dBuV/m) – Average limit (dBuV/m).



Operation Mode: TX / CH High
Temperature: 24°C
Humidity: 52 % RH

Test Date: February 18, 2011
Tested by: Sunday Hu
Polarity: Ver. / Hor.

Fundamental

Table with 11 columns: Freq. (MHz), Ant. Pol H/V, Peak Reading (dBuV), AV Reading (dBuV), Ant. / CL CF (dB), Actual Fs (Peak, AV), Peak Limit (dBuV/m), AV Limit (dBuV/m), Peak Margin (dB), AV Margin (dB). Rows include data for frequencies 2472 MHz.

Table with 11 columns: Freq. (MHz), Ant. Pol H/V, Peak Reading (dBuV), AV Reading (dBuV), Ant. / CL CF (dB), Actual Fs (Peak, AV), Peak Limit (dBuV/m), AV Limit (dBuV/m), Margin (dB), Remark. Rows include data for various frequencies from 1652.43 MHz to 7416.58 MHz, plus an N/A row.

REMARKS:

- 1. Measuring frequencies from 1 GHz to the 10th harmonic of highest fundamental frequency.
2. Radiated emissions measured in frequency above 1000MHz were made with an instrument using peak/average detector mode.
3. Average test would be performed if the peak result were greater than the average limit or as required by the applicant.
4. Data of measurement within this frequency range shown " --- " in the table above means the reading of emissions are attenuated more than 20dB below the permissible limits or the field strength is too small to be measured.
5. Measurements above show only up to 6 maximum emissions noted, or would be lesser, with " N/A " remark, if no specific emissions from the EUT are recorded (ie: margin>20dB from the applicable limit) and considered that's already beyond the background noise floor.
6. Margin (dB) = Remark result (dBuV/m) – Average limit (dBuV/m).