



**Spectrum Research  
& Testing Lab., Inc.**

No. 101-10, Ling 8,  
Shan-Tong Li, Chung-Li  
City, Taoyuan, Taiwan,  
R.O.C.

# TEST REPORT

Reference No.: A07112106  
Report No.: FCCA07112106  
FCC ID: HQXAGP-Y6  
Page:1 of 48  
Date: Nov. 29, 2007

Product Name: Wireless Presenter  
Model No.: AGP-Y6  
Trade Name: Sysgration  
Applicant: SYSGRATION LTD.  
10Fl., No.868, Chung Cheng Rd., Chung Ho, Taipei (235),  
Taiwan, R.O.C.  
Date of Receipt: Nov. 21, 2007  
Finished date of Test: Nov. 28, 2007  
Applicable Standards: 47 CFR Part 15, Subpart C, Class B  
ANSI C63.4:2003

We, **Spectrum Research & Testing Laboratory Inc.**, hereby certify that one sample of the above was tested in our laboratory with positive results according to the above-mentioned standards. The records in the report are an accurate account of the results. Details of the results are given in the subsequent pages of this report.

Tested By : Tim Mie , Date: Nov. 29, 2007  
(Tim Mie)

Approved By : Johnson Ho , Date: 11/29/2007  
(Johnson Ho, Director)

**NVLAQ**<sup>®</sup>

Lab Code: 200099-0  
FMNG-059.10 REPORT



## Table of Contents

1.	DOCUMENT POLICY AND TEST STATEMENT .....	4
1.1	DOCUMENT POLICY .....	4
1.2	TEST STATEMENT .....	4
1.3	EUT MODIFICATION .....	4
2.	DESCRIPTION OF EUT AND TEST MODE .....	5
2.1	GENERAL DESCRIPTION OF EUT .....	5
2.2	DESCRIPTION OF SUPPORT UNIT .....	5
2.3	DESCRIPTION OF TEST MODE .....	6
3.	DESCRIPTION OF APPLIED STANDARDS .....	6
4.	CONDUCTED EMISSION.....	7
4.1	LIMIT .....	7
4.2	TEST EQUIPMENT .....	7
4.3	TEST SETUP.....	8
4.4	TEST PROCEDURE.....	8
4.5	EUT OPERATING CONDITION .....	9
4.6	TEST RESULT .....	10
5.	RADIATED EMISSION TEST .....	12
5.1	RADIATED EMISSION LIMIT.....	12
5.2	TEST EQUIPMENT.....	13
5.3	TEST SET-UP(30MHZ - 1GHZ) .....	14
5.4	TEST SET- UP (1GHZ - 25GHZ).....	15
5.5	TEST PROCEDURE .....	16
5.6	EUT OPERATING CONDITION .....	16
5.7	RADIATED EMISSION TEST RESULT .....	17
6.	6 DB BANDWIDTH.....	25
6.1	LIMIT .....	25
6.2	TEST EQUIPMENT.....	25
6.3	TEST SET-UP .....	25
6.4	TEST PROCEDURE .....	25
6.5	EUT OPERATING CONDITION .....	25
6.6	TEST RESULT .....	26
7.	PEAK POWER TEST .....	29
7.1	LIMIT .....	29
7.2	TEST EQUIPMENT.....	29
7.3	TEST SET-UP .....	30
7.4	TEST PROCEDURE .....	30
7.5	EUT OPERATING CONDITION .....	30
7.6	TEST RESULT .....	30
8.	BAND EDGE TEST .....	34
8.1	LIMIT .....	34
8.2	TEST EQUIPMENT.....	35
8.3	TEST SET-UP .....	36
8.4	TEST PROCEDURE .....	37
8.5	EUT OPERATING CONDITION .....	37



**Spectrum Research  
& Testing Lab., Inc.**

No. 101-10, Ling 8,  
Shan-Tong Li, Chung-Li  
City, Taoyuan, Taiwan,  
R.O.C.

# TEST REPORT

Reference No.: A07112106  
Report No.: FCCA07112106  
FCC ID: HQXAGP-Y6  
Page:3 of 48  
Date: Nov. 29, 2007

8.6 TEST RESULT .....	37
9. POWER DENSITY TEST .....	40
9.1 LIMIT .....	40
9.2 TEST EQUIPMENT .....	40
9.3 TEST SET-UP .....	40
9.4 TEST PROCEDURE .....	40
9.5 EUT OPERATING CONDITION .....	40
9.6 TEST RESULT .....	41
10. ANTENNA APPLICATION .....	44
10.1 ANTENNA REQUIREMENT .....	44
10.2 RESULT .....	44
11. PHOTOS OF TESTING .....	45
12. TERMS OF ABBREVIATION .....	48



**Spectrum Research  
& Testing Lab., Inc.**

No. 101-10, Ling 8,  
Shan-Tong Li, Chung-Li  
City, Taoyuan, Taiwan,  
R.O.C.

# TEST REPORT

Reference No.: A07112106  
Report No.: FCCA07112106  
FCC ID: HQXAGP-Y6  
Page:4 of 48  
Date: Nov. 29, 2007

## 1. DOCUMENT POLICY AND TEST STATEMENT

### 1.1 DOCUMENT POLICY

- The report shall not be reproduced except in full, without the written approval of SRT Lab, Inc.
- The report must not be used by the applicant to claim that the product is endorsed by NVLAP, TÜV, NEMKO and SRT.
- The NVLAP logo applies only to the applicable standards specified in this report.

### 1.2 TEST STATEMENT

- The test results in the report apply only to the unit tested by SRT Lab.
- There was no deviation from the requirements of test standards during the test.
- AC power source, 120 Vac/60 Hz, was used during the test.

### 1.3 EUT MODIFICATION

- No modification in SRT Lab.



## 2. DESCRIPTION OF EUT AND TEST MODE

### 2.1 GENERAL DESCRIPTION OF EUT

<b>PRODUCT</b>	Wireless Presenter
<b>MODEL NO.</b>	AGP-Y6
<b>POWER REQUIREMENTS</b>	0.9V, 1.5A
<b>FREQUENCY BAND</b>	2400 ~ 2483.5MHz
<b>CARRIER FREQUENCY</b>	CH1: 2414 MHz    CH2: 2418 MHz CH3: 2462 MHz    CH4: 2466 MHz
<b>NUMBER OF CHANNEL</b>	4
<b>CHANNEL SPACING</b>	27.8 MHz
<b>RF OUTPUT POWER</b>	< -4dBm
<b>MODULATION TYPE</b>	GFSK
<b>ANTENNA TYPE</b>	PCB antenna
<b>ANTENNA GAIN</b>	0dBi
<b>BATTERY</b>	1.5V AAA Alkaline

#### NOTE :

For more detailed information, please refer to the EUT's specification or user's manual provided by manufacturer.

### 2.2 DESCRIPTION OF SUPPORT UNIT

The transmitter part of EUT was tested with a PC system and configured by the requirement of ANSI C63.4. All interface ports were connected to the appropriate support units via specific cables. The support units and cables are listed below.

NO	DEVICE	BRAND / MAKER	MODEL #	CABLE
1	NOTEBOOK	Compaq	Presario 2200	1.0m unshielded power cord with AC/DC adapter



**Spectrum Research  
& Testing Lab., Inc.**

No. 101-10, Ling 8,  
Shan-Tong Li, Chung-Li  
City, Taoyuan, Taiwan,  
R.O.C.

# TEST REPORT

Reference No.: A07112106  
Report No.: FCCA07112106  
FCC ID: HQXAGP-Y6  
Page:6 of 48  
Date: Nov. 29, 2007

## 2.3 DESCRIPTION OF TEST MODE

4 channels are provided by EUT, 3 channels of them were chosen for test.

Channel	Frequency (MHz)	Final Test
1	2414	V
2	2418	
3	2462	V
4	2466	V

**NOTE :**

1. Below 1 GHz, the 4 channels were pre-tested in chamber. The channel 1, the worst-case one, was chosen for final test.
2. Above 1 GHz, the channel 1,3 & 4 were tested individually.

## 3. DESCRIPTION OF APPLIED STANDARDS

The EUT is a kind of wireless product and to be connected with a PC system for normal use. According to the specifications provided by the applicant, it must comply with the requirements of the following standards:

47 CFR Part 15, Subpart C

ANSI C63.4:2003

All tests have been performed and recorded as the above standards.





## 4. CONDUCTED EMISSION

### 4.1 LIMIT

FREQUENCY (MHz)	Class A (dB $\mu$ V)		Class B (dB $\mu$ V)	
	Quasi-peak	Average	Quasi-peak	Average
0.15 - 0.5	79	66	66 - 56	56 - 46
0.5 - 5.0	73	60	56	46
5.0 - 30.0	73	60	60	50

**NOTE:**

1. The lower limit shall apply at the transition frequencies.
2. The limit decreases in line with the logarithm of the frequency in the range of 0.15 to 0.50 MHz.

### 4.2 TEST EQUIPMENT

The following test equipment was used for the test:

EQUIPMENT/ FACILITIES	SPECIFICATIONS	MANUFACTURER	MODEL#/ SERIAL#	DUE DATE OF CAL. & CAL. CENTER
EMI TEST RECEIVER	9 KHZ TO 30 MHZ	ROHDE & SCHWARZ	ESHS30/ 826003/008	OCT. 2008 ETC
LISN (for EUT)	50 $\mu$ H, 50 ohm	FCC	FCC-LISN-50-25-2/ 01017	OCT. 2008 ETC
LISN (for Peripheral)	50 $\mu$ H, 50 ohm	FCC	FCC-LISN-50-25-2/ 01018	NOV. 2008 ETC
50 ohm TERMINATOR	50 ohm	HP	11593A/ 2	OCT. 2008 ETC
COAXIAL CABLE	5m	SUNCITY	CABLE 05/ #5-5M	NOV. 2008 SRT
ISOLATION TRANSFORMER	N/A	APC	AFC-11015/ F102040016	N/A
FILTER	2 LINE, 30A	FIL.COIL	FC-943/ 771	N/A
GROUND PLANE	2.3M (H) x 2.4M (W)	SRT	N/A	N/A
GROUND PLANE	2.4M (H) x 2.4M (W)	SRT	N/A	N/A

**NOTE:** The calibration interval of the above test equipment is one year and the calibrations are traceable to NML/ROC and NIST/USA.

## 4.3 TEST SETUP

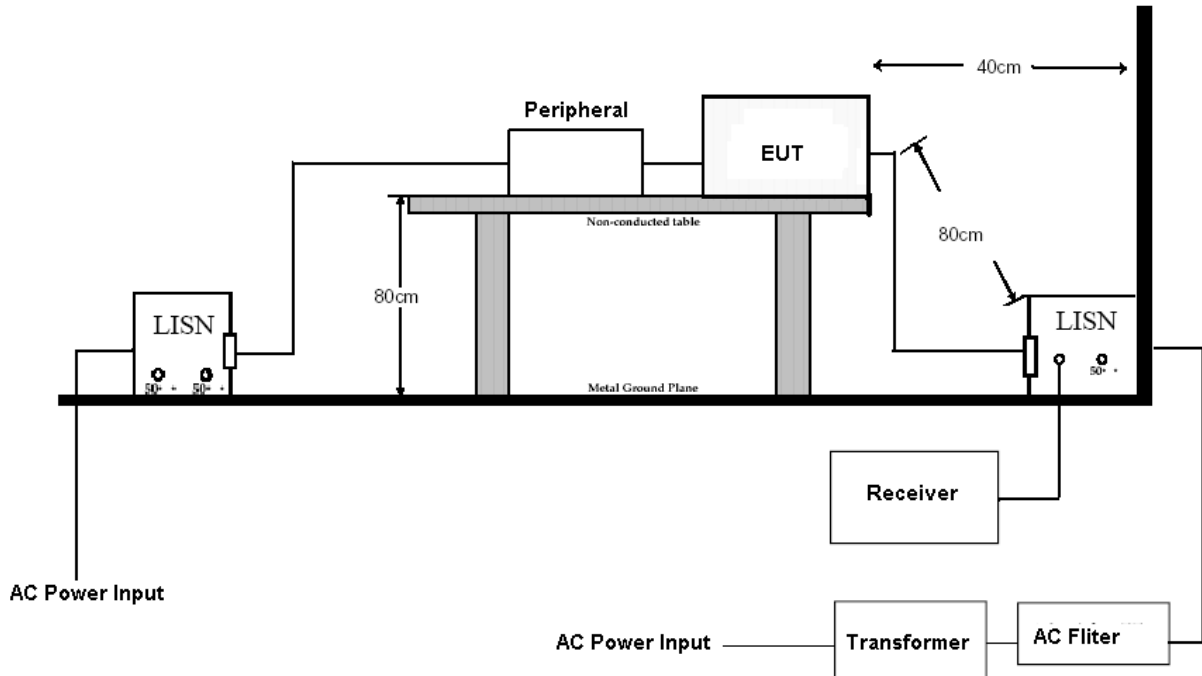

### NOTE:

1. The EUT was put on a wooden table with 0.8m height above ground plane, and 0.4m away from reference ground plane (> 2mx2m).
2. For the actual test configuration, please refer to the photos of testing.
3. The serial no. of the LISN connected to EUT is 951318.
4. The serial no. of the LISN connected to support units is 924839.

## 4.4 TEST PROCEDURE

The EUT was tested according to the requirement of ANSI C63.4: 2003 and CISRP22:2006. The frequency spectrum from 0.15 MHz to 30 MHz was investigated. The LISN used was 50 ohm/50μH as specified. All readings were quasi-peak and average values with 10 kHz resolution bandwidth of the test receiver. The EUT system was operated in all typical methods by users. Both lines of the power mains of EUT were measured and the cables connected to EUT and support units were moved to find the maximum emission levels for each frequency.





**Spectrum Research  
& Testing Lab., Inc.**

No. 101-10, Ling 8,  
Shan-Tong Li, Chung-Li  
City, Taoyuan, Taiwan,  
R.O.C.

# TEST REPORT

Reference No.: A07112106  
Report No.: FCCA07112106  
FCC ID: HQXAGP-Y6  
Page:9 of 48  
Date: Nov. 29, 2007

## 4.5 EUT OPERATING CONDITION

Set the EUT under transmission condition continuously at a specific channel frequency.

Under Windows XP ran “EMI TEST” program, PC sent “H” pattern or accessed the following peripherals:

- Presenter (EUT)
- Receiver (EUT)



## 4.6 TEST RESULT

Temperature:	27°C	Humidity:	62%RH
Frequency Range:	0.15 – 30 MHz	Tested Mode:	Standby
Receiver Detector:	Q.P. and AV.	Tested By:	Tim Mie
		Tested Date:	Nov. 24, 2007

Power Line Measured : Line

Freq. (MHz)	Correct. Factor (dB)	Reading Value (dB $\mu$ V)		Emission Level (dB $\mu$ V)		Limit (dB $\mu$ V)		Margin (dB)	
		Q.P.	AV.	Q.P.	AV.	Q.P.	AV.	Q.P.	AV.
0.174	0.30	47.60	33.91	47.90	34.21	65.31	55.31	-17.41	-21.10
0.177	0.30	46.18	32.65	46.48	32.95	65.23	55.23	-18.75	-22.28
1.162	0.14	28.36	26.35	28.50	26.49	56.00	46.00	-27.50	-19.51
3.833	0.20	29.46	28.50	29.66	28.70	56.00	46.00	-26.34	-17.30
6.502	0.22	25.92	21.47	26.14	21.69	60.00	50.00	-33.86	-28.31
28.007	0.46	20.54	15.57	21.00	16.03	60.00	50.00	-39.00	-33.97

Power Line Measured : Neutral

Freq. (MHz)	Correct. Factor (dB)	Reading Value (dB $\mu$ V)		Emission Level (dB $\mu$ V)		Limit (dB $\mu$ V)		Margin (dB)	
		Q.P.	AV.	Q.P.	AV.	Q.P.	AV.	Q.P.	AV.
0.174	0.30	47.46	33.47	47.76	33.77	65.31	55.31	-17.55	-21.54
0.177	0.30	46.16	32.54	46.46	32.84	65.23	55.23	-18.77	-22.39
1.162	0.14	28.12	26.13	28.26	26.27	56.00	46.00	-27.74	-19.73
4.299	0.20	26.90	23.92	27.10	24.12	56.00	46.00	-28.90	-21.88
6.512	0.22	32.60	29.87	32.82	30.09	60.00	50.00	-27.18	-19.91
26.798	0.31	20.08	13.59	20.39	13.90	60.00	50.00	-39.61	-36.10

### NOTE :

1. Measurement uncertainty is +/-2dB
2. Emission level = Reading value + Correction factor
3. Correction Factor = Cable loss + Insertion loss of LISN
4. Margin value = Emission level - Limit
5. The emission of other frequencies were very low against the limit.
6. "-": The Quasi-peak reading value also meets average limit and measurement with the average detector is unnecessary.

**Spectrum Research & Testing Lab., Inc.**No. 101-10, Ling 8,  
Shan-Tong Li, Chung-Li  
City, Taoyuan, Taiwan,  
R.O.C.**TEST REPORT**Reference No.: A07112106  
Report No.: FCCA07112106  
FCC ID: HQXAGP-Y6  
Page:11 of 48  
Date: Nov. 29, 2007

Temperature:	<u>27°C</u>	Humidity:	<u>62%RH</u>
Frequency Range:	<u>0.15 – 30 MHz</u>	Tested Mode:	<u>Link</u>
Receiver Detector:	<u>Q.P. and AV.</u>	Tested By:	<u>Tim Mie</u>
		Tested Date:	<u>Nov. 24, 2007</u>

Power Line Measured : Line

Freq. (MHz)	Correct. Factor (dB)	Reading Value (dB $\mu$ V)		Emission Level (dB $\mu$ V)		Limit (dB $\mu$ V)		Margin (dB)	
		Q.P.	AV.	Q.P.	AV.	Q.P.	AV.	Q.P.	AV.
0.171	0.30	47.68	36.56	47.98	36.86	65.40	55.40	-17.42	-18.54
0.174	0.30	48.16	36.95	48.46	37.25	65.31	55.31	-16.85	-18.06
0.519	0.24	24.14	17.10	24.38	17.34	56.00	46.00	-31.62	-28.66
2.536	0.17	28.40	25.29	28.57	25.46	56.00	46.00	-27.43	-20.54
7.091	0.22	27.70	14.40	27.92	14.62	60.00	50.00	-32.08	-35.38
29.514	0.49	21.46	15.72	21.95	16.21	60.00	50.00	-38.05	-33.79

Power Line Measured : Neutral

Freq. (MHz)	Correct. Factor (dB)	Reading Value (dB $\mu$ V)		Emission Level (dB $\mu$ V)		Limit (dB $\mu$ V)		Margin (dB)	
		Q.P.	AV.	Q.P.	AV.	Q.P.	AV.	Q.P.	AV.
0.171	0.30	47.84	36.58	48.14	36.88	65.40	55.40	-17.26	-18.52
0.174	0.30	48.76	37.42	49.06	37.72	65.31	55.31	-16.25	-17.59
1.153	0.14	37.40	31.58	37.54	31.72	56.00	46.00	-18.46	-14.28
4.724	0.21	36.48	33.43	36.69	33.64	56.00	46.00	-19.31	-12.36
7.781	0.23	31.04	23.94	31.27	24.17	60.00	50.00	-28.73	-25.83
15.195	0.25	17.16	11.46	17.41	11.71	60.00	50.00	-42.59	-38.29

**NOTE :**

1. Measurement uncertainty is +/-2dB
2. Emission level = Reading value + Correction factor
3. Correction Factor = Cable loss + Insertion loss of LISN
4. Margin value = Emission level - Limit
5. The emission of other frequencies were very low against the limit.
6. "-": The Quasi-peak reading value also meets average limit and measurement with the average detector is unnecessary.



# TEST REPORT

## 5. RADIATED EMISSION TEST

### 5.1 RADIATED EMISSION LIMIT

FCC Part 15, Subpart C Section 15.209

FREQUENCY (MHz)	DISTANCE (m)	FIELD STRENGTH (dB $\mu$ V/m)
30 - 88	3	40.0
88 - 216	3	43.5
216 - 960	3	46.0
Above 960	3	54.0

**NOTE :**

1. In the emission tables above , the tighter limit applies at the band edges.
2. Distance refers to the distance between measuring instrument, antenna, and the closest point of any part of the device or system.

FCC Part 15, Section15.35(b) limit of radiated emission for frequency above 1000 MHz

Frequency (MHz)	Class A (dBuV/m) (at 3m)		Class B (dBuV/m) (at 3m)	
	Peak	Average	Peak	Average
Above 1000	80.0	60.0	74.0	54.0

FCC Part 15, Subpart C Section 15.249/ The field strength of emissions from intentional radiators operated within these frequency bands shall comply with the following:

Fundamental Frequency (MHz)	Filed Strength of Fundamental (dBuV/m) (at 3m)		Field Strength of Harmonics (dBuV/m) (at 3m)	
	Peak	Average	Peak	Average
902-928	114	94	74.0	54.0
2400-2483.5	114	94	74.0	54.0
5725-5875	114	94	74.0	54.0
24000-24250	128	108	88.0	68.0

 <b>Spectrum Research &amp; Testing Lab., Inc.</b> No. 101-10, Ling 8, Shan-Tong Li, Chung-Li City, Taoyuan, Taiwan, R.O.C.	<h1>TEST REPORT</h1>	Reference No.: A07112106 Report No.: FCCA07112106 FCC ID: HQXAGP-Y6 Page:13 of 48 Date: Nov. 29, 2007
--	----------------------	---

## 5.2 TEST EQUIPMENT

The following test equipment was used during the radiated emission test:

EQUIPMENT/ FACILITIES	SPECIFICATIONS	MANUFACTURER	MODEL#/ SERIAL#	DUE DATE OF CAL. & CAL. CENTER
EMI TEST RECEIVER	9 kHz TO 1 GHz	ROHDE & SCHWARZ	ESCS30/ 830245/012	OCT. 2008 ETC
BI-LOG ANTENNA	25 MHz TO 2 GHz	EMCO	3143/ 9509-1141	SEP. 2008 SRT
SPECTRUM ANALYZER	9 KHz TO 26.5 GHz	HP	8593E/ 3710A03220	MAY 2008 ETC
PRE-AMPLIFIER	1 GHz TO 26.5 GHz	HP	8449B/ 3008A01019	NOV. 2008 ETC
OATS	3 – 10 M MEASUREMENT	SRT	SRT-1	DEC. 2007 SRT
COAXIAL CABLE	25M	SUNCITY	J400/ 25M	AUG. 2008 SRT
FILTER	2 LINE, 30A	FIL.COIL	FC-943/ 869	N/A
FREQUENCY CONVERTER	N/A	APC	AFC-2KBB/ F100030031	AUG. 2008 SRT

### NOTE:

1. The calibration interval of the above test equipment is one year and the calibrations are traceable to NML/ROC and NIST/USA.
2. The Open Area Test Site (SRT-1) is registered by FCC with No. 90957 and VCCI with No. R-1081.
3. The Open Area Test Site (SRT-2) is registered by FCC with No. 98458 and VCCI with No. R-1168.



## 5.3 TEST SET-UP(30MHz - 1GHz)

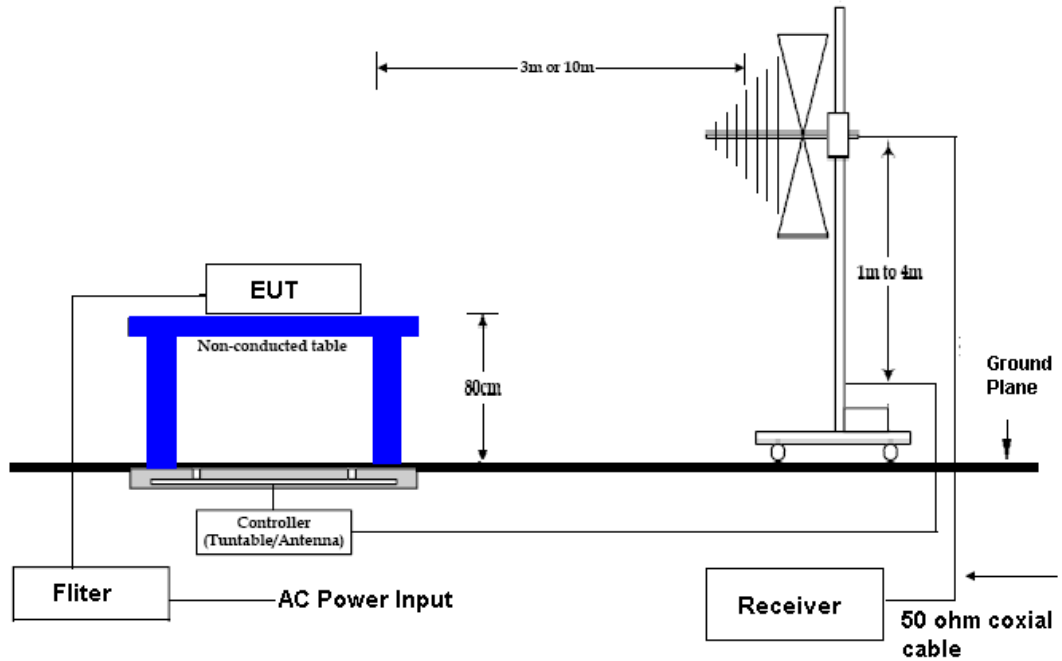

### NOTE :

1. The EUT system was put on a wooden table with 0.8m heights above a ground plane.
2. For the actual test configuration, please refer to the photos of testing.



## 5.4 TEST SET- UP (1GHz - 25GHz)

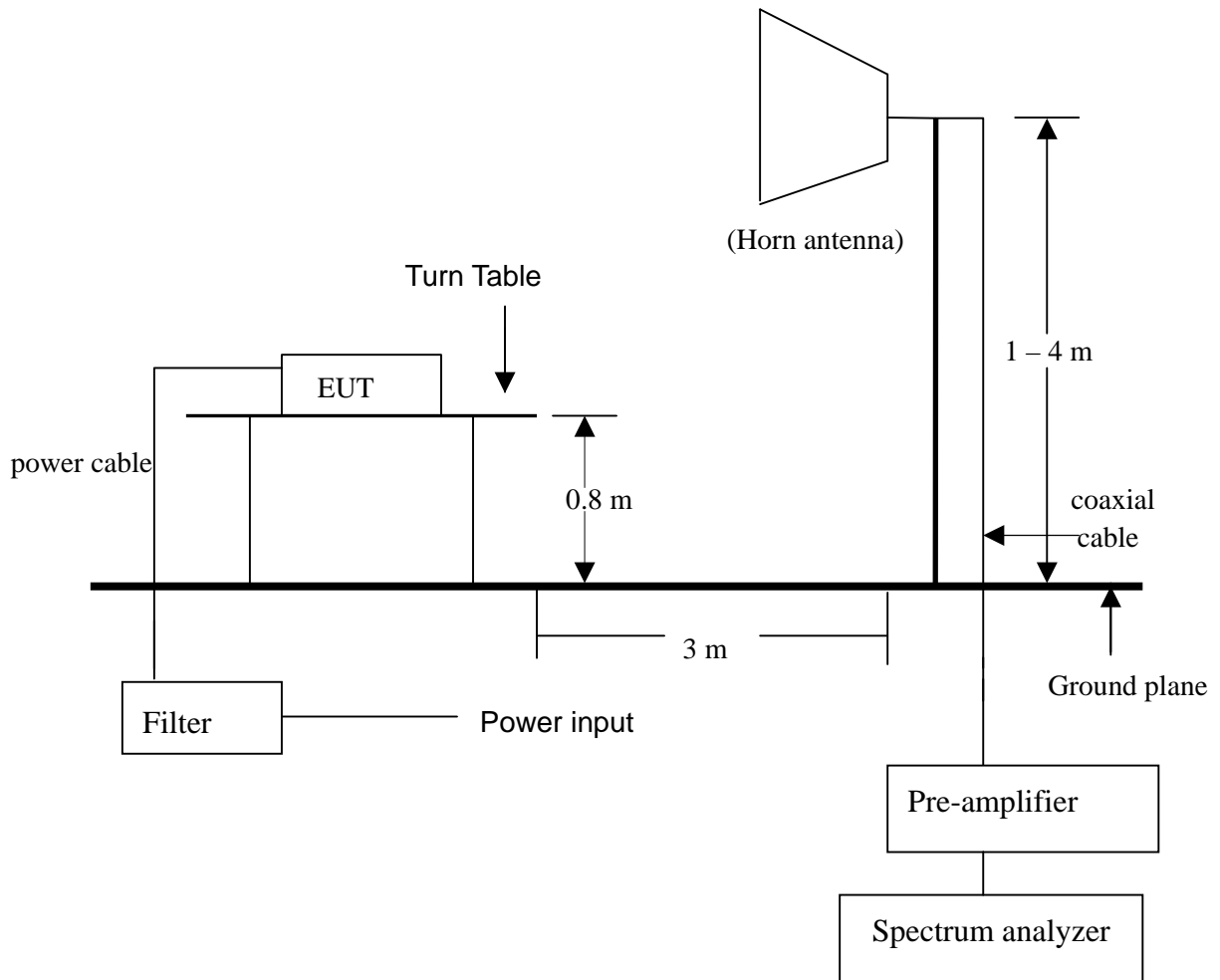

### NOTE :

- 1.The EUT system was put on a wooden table with 0.8m heights above a ground plane.
- 2.For the actual test configuration, please refer to the photos of testing.





**Spectrum Research  
& Testing Lab., Inc.**

No. 101-10, Ling 8,  
Shan-Tong Li, Chung-Li  
City, Taoyuan, Taiwan,  
R.O.C.

# TEST REPORT

Reference No.: A07112106  
Report No.: FCCA07112106  
FCC ID: HQXAGP-Y6  
Page:16 of 48  
Date: Nov. 29, 2007

## 5.5 TEST PROCEDURE

The EUT was tested according to the requirement of ANSI C63.4 / CISPR 22 and RSS-Gen. The measurements were made at an open area test site with 10 meter measurement distance under 1 GHz and with 3m distance above 1GHz. The frequency spectrum measured started from 30 MHz. Under 1 GHz, all readings were quasi-peak values with 120 kHz resolution bandwidth of the test receiver. Above 1 GHz, the measurements were made at an open area test site with 3 meter measurement distance and all readings were peak or average values with 1 MHz resolution bandwidth of the test receiver. The EUT system was operated in all typical methods by users. The cables connected to EUT and support units were moved to find the maximum emission levels for each frequency.

## 5.6 EUT OPERATING CONDITION

Same as section 4.5 of this report.



# TEST REPORT

## 5.7 RADIATED EMISSION TEST RESULT

Temperature:	25°C	Humidity:	55%RH
Ferquency Range:	30 – 1000 MHz	Test mode:	CH1-Link
Receiver Detector:	Q.P.	Measured Distance:	3m
Tested by:	Tim Mie	Tested Date:	Nov. 21, 2007

Antenna Polarization : Horizontal

Frequency (MHz)	Cable Loss (dB)	Antenna Factor (dB/m)	Reading Data (dBμV)	Emission Level (dBμV/m)	Limit (dBμV/m)	Margin (dB)	AZ(°)	EL(m)
63.2530	1.29	7.24	14.3	22.8	40.0	-17.2	133	12
216.4500	2.60	10.70	13.5	26.8	46.0	-19.2	115	1.5
300.0000	3.05	14.11	17.9	35.1	46.0	-10.9	341	1.3
330.1960	3.18	16.21	11.0	30.4	46.0	-15.6	124	1.9
527.7400	4.27	18.81	16.3	39.4	46.0	-6.6	44	1.8
578.6700	4.54	19.30	14.3	38.1	46.0	-7.9	65	1.3

Antenna Polarization : Vertical

Frequency (MHz)	Cable Loss (dB)	Antenna Factor (dB/m)	Reading Data (dBμV)	Emission Level (dBμV/m)	Limit (dBμV/m)	Margin (dB)	AZ(°)	EL(m)
46.6700	1.10	8.07	19.0	28.2	40.0	-11.8	32	1.1
331.2694	3.19	16.39	9.6	29.2	46.0	-16.8	43	1.3
550.2100	4.37	19.40	13.2	37.0	46.0	-9.0	224	1.4
900.5800	5.93	24.70	9.8	40.4	46.0	-5.6	321	1.2
527.6500	4.27	18.81	18.3	41.4	46.0	-4.6	112	1.3
663.0100	4.96	20.46	15.6	41.0	46.0	-5.0	311	1.2

- NOTE :**
1. Measurement uncertainty is less than +/-2dB
  2. "\*": Measurement does not apply for this frequency.
  3. Emission Level = Reading Value + Ant. Factor + Cable Loss
  4. The field strength of other emission frequencies were very low against the limit.

**Spectrum Research & Testing Lab., Inc.**No. 101-10, Ling 8,  
Shan-Tong Li, Chung-Li  
City, Taoyuan, Taiwan,  
R.O.C.**TEST REPORT**Reference No.: A07112106  
Report No.: FCCA07112106  
FCC ID: HQXAGP-Y6  
Page:18 of 48  
Date: Nov. 29, 2007

Temperature:	25°C	Humidity:	55%RH
Frequency Range:	30 – 1000 MHz	Test mode:	CH1-Standby
Receiver Detector:	Q.P.	Measured Distance:	3m
Tested by:	Tim Mie	Tested Date:	Nov. 21, 2007

Antenna Polarization : Horizontal

Frequency (MHz)	Cable Loss (dB)	Antenna Factor (dB/m)	Reading Data (dBμV)	Emission Level (dBμV/m)	Limit (dBμV/m)	Margin (dB)	AZ(°)	EL(m)
123.6900	1.90	6.72	10.3	18.9	43.5	-24.6	143	1.9
143.7100	2.02	10.21	10.1	22.3	43.5	-21.2	224	1.7
166.9100	2.27	9.77	9.4	21.4	43.5	-22.1	32	1.5
233.0400	2.68	11.34	8.9	22.9	46.0	-23.1	131	1.5
541.6300	4.30	19.13	11.2	34.6	46.0	-11.4	31	1.3
882.9100	5.77	24.24	8.7	38.7	46.0	-7.3	123	1.2

Antenna Polarization : Vertical

Frequency (MHz)	Cable Loss (dB)	Antenna Factor (dB/m)	Reading Data (dBμV)	Emission Level (dBμV/m)	Limit (dBμV/m)	Margin (dB)	AZ(°)	EL(m)
124.1900	1.91	7.01	11.1	20.0	43.5	-23.5	324	1.3
138.9400	1.99	9.80	10.1	21.9	43.5	-21.6	139	1.5
165.9400	2.26	9.84	9.5	21.6	43.5	-21.9	122	1.6
233.6500	2.68	11.34	9.3	23.3	46.0	-22.7	227	1.4
526.4300	4.28	18.78	10.8	33.9	46.0	-12.1	132	1.1
881.5683	5.74	24.22	7.3	37.3	46.0	-8.7	277	1.5

- NOTE :**
1. Measurement uncertainty is less than +/-2dB
  2. "\*\*": Measurement does not apply for this frequency.
  3. Emission Level = Reading Value + Ant. Factor + Cable Loss
  4. The field strength of other emission frequencies were very low against the limit.

**Spectrum Research & Testing Lab., Inc.**No. 101-10, Ling 8,  
Shan-Tong Li, Chung-Li  
City, Taoyuan, Taiwan,  
R.O.C.**TEST REPORT**Reference No.: A07112106  
Report No.: FCCA07112106  
FCC ID: HQXAGP-Y6  
Page:19 of 48  
Date: Nov. 29, 2007

Temperature:	24°C	Humidity:	67%RH
Ferquency Range:	1 – 25 GHz	Test mode:	CH1-Link
Receiver Detector:	PK. or AV.	Measured Distance:	3m
Tested by:	Tim Mie	Tested Date:	Nov. 21, 2007

Antenna Polarization : Horizontal

Frequency (MHz)	Cable Loss (dB)	Ant. Fact. (dB)	Reading (dBuV)		Emission (dBuV/m)		Limit Line (dBuV/m)		Margin (dBuV/m)		AZ (°)	EL (m)
			PK	AV	PK	AV	PK	AV	PK	AV		
2414.00	-32.18	28.03	60.2	47.9	56.0	43.7	74.0	54.0	-18.0	-10.3	32	1.5
4828.00	-30.40	33.66	35.7	*	39.0	*	74.0	54.0	-35.0	*	114	1.4
7242.00	-29.00	36.29	38.4	*	45.7	*	74.0	54.0	-28.3	*	126	1.6
2368.16	-32.28	27.94	31.5	*	27.2	*	74.0	54.0	-46.8	*	43	1.4
2397.52	-32.17	27.99	32.6	*	28.4	*	74.0	54.0	-45.6	*	322	1.3
2435.82	-32.22	28.07	33.4	*	29.3	*	74.0	54.0	-44.7	*	143	1.4

Antenna Polarization : Vertical

Frequency (MHz)	Cable Loss (dB)	Ant. Fact. (dB)	Reading (dBuV)		Emission (dBuV/m)		Limit Line (dBuV/m)		Margin (dBuV/m)		AZ (o)	EL (m)
			PK	AV	PK	AV	PK	AV	PK	AV		
2414.00	-32.18	28.03	65.3	49.2	61.1	45.0	74.0	54.0	-12.9	-9.0	101	1.4
4828.00	-30.40	33.66	37.5	*	40.7	*	74.0	54.0	-33.3	*	254	1.4
7242.00	-29.00	36.29	38.1	*	45.4	*	74.0	54.0	-28.6	*	95	1.2
2348.87	-32.35	27.90	40.7	*	36.2	*	74.0	54.0	-37.8	*	147	1.3
2399.34	-32.16	28.00	42.5	*	38.3	*	74.0	54.0	-35.7	*	80	1.1
2469.74	-32.21	28.14	47.0	*	42.9	*	74.0	54.0	-31.1	*	276	1.2

- NOTE :**
1. Measurement uncertainty is less than +/-2dB
  2. "\*": Measurement does not apply for this frequency.
  3. Emission Level = Reading Value + Ant. Factor + Cable Loss(included Pre-amplifier)
  4. The field strength of other emission frequencies were very low against the limit.
  5. The tested value of over 10GHz is too weak to record.

**Spectrum Research & Testing Lab., Inc.**No. 101-10, Ling 8,  
Shan-Tong Li, Chung-Li  
City, Taoyuan, Taiwan,  
R.O.C.**TEST REPORT**Reference No.: A07112106  
Report No.: FCCA07112106  
FCC ID: HQXAGP-Y6  
Page:20 of 48  
Date: Nov. 29, 2007

Temperature:	24°C	Humidity:	67%RH
Ferquency Range:	1 – 25 GHz	Test mode:	CH1-TX
Receiver Detector:	PK. or AV.	Measured Distance:	3m
Tested by:	Tim Mie	Tested Date:	Nov. 21, 2007

Antenna Polarization : Horizontal

Frequency (MHz)	Cable Loss (dB)	Ant. Fact. (dB)	Reading (dBUV)		Emission (dBUV/m)		Limit Line (dBUV/m)		Margin (dBUV/m)		AZ (°)	EL (m)
			PK	AV	PK	AV	PK	AV	PK	AV		
2414.00	-32.18	28.03	68.9	50.3	64.7	46.1	74.0	54.0	-9.3	-7.9	237	1.9
4828.00	-30.40	33.66	41.0	*	44.3	*	74.0	54.0	-29.7	*	155	1.7
7242.00	-29.00	36.29	37.5	*	44.8	*	74.0	54.0	-29.2	*	109	1.5
2387.24	-32.21	27.97	38.5	*	34.3	*	74.0	54.0	-39.7	*	213	1.3
2396.43	-32.18	27.99	42.6	*	38.4	*	74.0	54.0	-35.6	*	75	1.1
2468.43	-32.21	28.14	45.3	*	41.3	*	74.0	54.0	-32.7	*	125	1.1

Antenna Polarization : Vertical

Frequency (MHz)	Cable Loss (dB)	Ant. Fact. (dB)	Reading (dBUV)		Emission (dBUV/m)		Limit Line (dBUV/m)		Margin (dBUV/m)		AZ (°)	EL (m)
			PK	AV	PK	AV	PK	AV	PK	AV		
2414.00	-32.18	28.03	65.3	49.2	61.1	45.0	74.0	54.0	-12.9	-9.0	101	1.2
4828.00	-30.40	33.66	37.5	*	40.7	*	74.0	54.0	-33.3	*	254	1.3
7242.00	-29.00	36.29	38.1	*	45.4	*	74.0	54.0	-28.6	*	95	1.3
2397.43	-32.17	27.99	40.7	*	36.5	*	74.0	54.0	-37.5	*	147	1.4
2443.91	-32.23	28.09	42.5	*	38.4	*	74.0	54.0	-35.6	*	80	1.6
2486.55	-32.18	28.17	47.0	*	43.0	*	74.0	54.0	-31.0	*	276	1.4

- NOTE :**
1. Measurement uncertainty is less than +/-2dB
  2. "\*": Measurement does not apply for this frequency.
  3. Emission Level = Reading Value + Ant. Factor + Cable Loss(included Pre-amplifier)
  4. The field strength of other emission frequencies were very low against the limit.
  5. The tested value of over 10GHz is too weak to record.

 <b>Spectrum Research &amp; Testing Lab., Inc.</b> No. 101-10, Ling 8, Shan-Tong Li, Chung-Li City, Taoyuan, Taiwan, R.O.C.	<h1>TEST REPORT</h1>	Reference No.: A07112106
		Report No.: FCCA07112106
		FCC ID: HQXAGP-Y6
		Page:21 of 48
		Date: Nov. 29, 2007

Temperature:	24°C	Humidity:	67%RH
Ferquency Range:	1 – 25 GHz	Test mode:	CH3-Link
Receiver Detector:	PK. or AV.	Measured Distance:	3m
Tested by:	Tim Mie	Tested Date:	Nov. 21, 2007

Antenna Polarization : Horizontal

Frequency (MHz)	Cable Loss (dB)	Ant. Fact. (dB)	Reading (dBUV)		Emission (dBUV/m)		Limit Line (dBUV/m)		Margin (dBUV/m)		AZ (°)	EL (m)
			PK	AV	PK	AV	PK	AV	PK	AV		
2462.00	-32.22	28.12	68.2	47.8	64.1	43.7	74.0	54.0	-9.9	-10.3	46	1.9
4924.00	-30.23	33.74	35.8	*	39.3	*	74.0	54.0	-34.7	*	155	1.6
7386.00	-28.94	36.41	36.2	*	43.7	*	74.0	54.0	-30.3	*	339	1.5
2397.16	-32.17	27.99	32.4	*	28.2	*	74.0	54.0	-45.8	*	235	1.4
2423.67	-32.20	28.05	32.1	*	27.9	*	74.0	54.0	-46.1	*	155	1.3
2469.61	-32.21	28.14	31.2	*	27.1	*	74.0	54.0	-46.9	*	298	1.1

Antenna Polarization : Vertical

Frequency (MHz)	Cable Loss (dB)	Ant. Fact. (dB)	Reading (dBUV)		Emission (dBUV/m)		Limit Line (dBUV/m)		Margin (dBUV/m)		AZ (o)	EL (m)
			PK	AV	PK	AV	PK	AV	PK	AV		
2462.00	-32.22	28.12	60.2	49.3	56.1	45.2	74.0	54.0	-17.9	-8.8	174	1.1
4924.00	-30.23	33.74	37.6	*	41.1	*	74.0	54.0	-32.9	*	331	1.2
7386.00	-28.94	36.41	35.9	*	43.4	*	74.0	54.0	-30.6	*	112	1.4
2394.18	-32.18	27.99	32.6	*	28.4	*	74.0	54.0	-45.6	*	243	1.3
2483.47	-32.19	28.17	31.7	*	27.7	*	74.0	54.0	-46.3	*	36	1.6
2512.74	-32.08	28.27	32.6	*	28.8	*	74.0	54.0	-45.2	*	146	1.7

- NOTE :**
1. Measurement uncertainty is less than +/-2dB
  2. "\*": Measurement does not apply for this frequency.
  3. Emission Level = Reading Value + Ant. Factor + Cable Loss(included Pre-amplifier)
  4. The field strength of other emission frequencies were very low against the limit.
  5. The tested value of over 10GHz is too weak to record.

**Spectrum Research & Testing Lab., Inc.**No. 101-10, Ling 8,  
Shan-Tong Li, Chung-Li  
City, Taoyuan, Taiwan,  
R.O.C.**TEST REPORT**Reference No.: A07112106  
Report No.: FCCA07112106  
FCC ID: HQXAGP-Y6  
Page:22 of 48  
Date: Nov. 29, 2007

Temperature:	24°C	Humidity:	67%RH
Ferquency Range:	1 – 25 GHz	Test mode:	CH3-TX
Receiver Detector:	PK. or AV.	Measured Distance:	3m
Tested by:	Tim Mie	Tested Date:	Nov. 21, 2007

Antenna Polarization : Horizontal

Frequency (MHz)	Cable Loss (dB)	Ant. Fact. (dB)	Reading (dBUV)		Emission (dBUV/m)		Limit Line (dBUV/m)		Margin (dBUV/m)		AZ (°)	EL (m)
			PK	AV	PK	AV	PK	AV	PK	AV		
2462.00	-32.22	28.12	64.0	52.0	59.9	47.9	74.0	54.0	-14.1	-6.1	133	1.8
4924.00	-30.23	33.74	36.8	*	40.3	*	74.0	54.0	-33.7	*	177	1.6
7386.00	-28.94	36.41	34.2	*	41.7	*	74.0	54.0	-32.3	*	144	1.5
2337.69	-32.35	27.87	33.6	*	29.1	*	74.0	54.0	-44.9	*	132	1.3
2412.66	-32.18	28.02	31.9	*	27.7	*	74.0	54.0	-46.3	*	117	1.2
2487.62	-32.18	28.17	32.7	*	28.7	*	74.0	54.0	-45.3	*	169	1.2

Antenna Polarization : Vertical

Frequency (MHz)	Cable Loss (dB)	Ant. Fact. (dB)	Reading (dBUV)		Emission (dBUV/m)		Limit Line (dBUV/m)		Margin (dBUV/m)		AZ (°)	EL (m)
			PK	AV	PK	AV	PK	AV	PK	AV		
2462.00	-32.22	28.12	64.8	51.7	60.7	47.6	74.0	54.0	-13.3	-6.4	134	1.2
4924.00	-30.23	33.74	36.8	*	40.3	*	74.0	54.0	-33.7	*	13	1.4
7386.00	-28.94	36.41	35.1	*	42.6	*	74.0	54.0	-31.4	*	116	1.3
2359.74	-32.32	27.92	32.6	*	28.2	*	74.0	54.0	-45.8	*	88	1.4
2429.62	-32.21	28.06	33.9	*	29.8	*	74.0	54.0	-44.2	*	331	1.5
2510.36	-32.09	28.26	32.1	*	28.3	*	74.0	54.0	-45.7	*	266	1.4

- NOTE :**
1. Measurement uncertainty is less than +/-2dB
  2. "\*": Measurement does not apply for this frequency.
  3. Emission Level = Reading Value + Ant. Factor + Cable Loss(included Pre-amplifier)
  4. The field strength of other emission frequencies were very low against the limit.
  5. The tested value of over 10GHz is too weak to record.



 <b>Spectrum Research &amp; Testing Lab., Inc.</b> No. 101-10, Ling 8, Shan-Tong Li, Chung-Li City, Taoyuan, Taiwan, R.O.C.	<h1>TEST REPORT</h1>	Reference No.: A07112106
		Report No.: FCCA07112106
		FCC ID: HQXAGP-Y6
		Page:23 of 48
		Date: Nov. 29, 2007

Temperature:	24°C	Humidity:	67%RH
Ferquency Range:	1 – 25 GHz	Test mode:	CH4-Link
Receiver Detector:	PK. or AV.	Measured Distance:	3m
Tested by:	Tim Mie	Tested Date:	Nov. 21, 2007

Antenna Polarization : Horizontal

Frequency (MHz)	Cable Loss (dB)	Ant. Fact. (dB)	Reading (dBuV)		Emission (dBuV/m)		Limit Line (dBuV/m)		Margin (dBuV/m)		AZ (°)	EL (m)
			PK	AV	PK	AV	PK	AV	PK	AV		
2466.00	-32.21	28.13	62.7	47.1	58.6	43.0	74.0	54.0	-15.4	-11.0	222	1.9
4932.00	-30.24	33.75	37.2	*	40.7	*	74.0	54.0	-33.3	*	327	1.6
7398.00	-28.93	36.42	35.4	*	42.9	*	74.0	54.0	-31.1	*	44	1.3
2355.86	-32.33	27.91	33.0	*	28.6	*	74.0	54.0	-45.4	*	126	1.4
2476.55	-32.20	28.15	32.4	*	28.4	*	74.0	54.0	-45.6	*	199	1.2
2489.90	-32.18	28.18	33.5	*	29.5	*	74.0	54.0	-44.5	*	143	1.1

Antenna Polarization : Vertical

Frequency (MHz)	Cable Loss (dB)	Ant. Fact. (dB)	Reading (dBuV)		Emission (dBuV/m)		Limit Line (dBuV/m)		Margin (dBuV/m)		AZ (o)	EL (m)
			PK	AV	PK	AV	PK	AV	PK	AV		
2466.00	-32.21	28.13	61.5	45.1	57.4	41.0	74.0	54.0	-16.6	-13.0	21	1.1
4932.00	-30.24	33.75	38.0	*	41.5	*	74.0	54.0	-32.5	*	324	1.1
7398.00	-28.93	36.42	37.1	*	44.6	*	74.0	54.0	-29.4	*	344	1.2
2413.87	-32.18	28.03	32.7	*	28.5	*	74.0	54.0	-45.5	*	325	1.4
2458.91	-32.23	28.12	32.9	*	28.8	*	74.0	54.0	-45.2	*	184	1.5
2484.51	-32.19	28.17	31.6	*	27.6	*	74.0	54.0	-46.4	*	166	1.5

- NOTE :**
1. Measurement uncertainty is less than +/-2dB
  2. "\*": Measurement does not apply for this frequency.
  3. Emission Level = Reading Value + Ant. Factor + Cable Loss(included Pre-amplifier)
  4. The field strength of other emission frequencies were very low against the limit.
  5. The tested value of over 10GHz is too weak to record.

**Spectrum Research & Testing Lab., Inc.**No. 101-10, Ling 8,  
Shan-Tong Li, Chung-Li  
City, Taoyuan, Taiwan,  
R.O.C.**TEST REPORT**Reference No.: A07112106  
Report No.: FCCA07112106  
FCC ID: HQXAGP-Y6  
Page:24 of 48  
Date: Nov. 29, 2007

Temperature:	24°C	Humidity:	67%RH
Ferquency Range:	1 – 25 GHz	Test mode:	CH4-TX
Receiver Detector:	PK. or AV.	Measured Distance:	3m
Tested by:	Tim Mie	Tested Date:	Nov. 21, 2007

Antenna Polarization : Horizontal

Frequency (MHz)	Cable Loss (dB)	Ant. Fact. (dB)	Reading (dBUV)		Emission (dBUV/m)		Limit Line (dBUV/m)		Margin (dBUV/m)		AZ (°)	EL (m)
			PK	AV	PK	AV	PK	AV	PK	AV		
2466.00	-32.21	28.13	60.9	48.9	56.8	44.8	74.0	54.0	-17.2	-9.2	234	1.8
4932.00	-30.24	33.75	38.1	*	41.6	*	74.0	54.0	-32.4	*	123	1.5
7398.00	-28.93	36.42	37.1	*	44.6	*	74.0	54.0	-29.4	*	54	1.4
2337.70	-32.35	27.87	32.9	*	28.4	*	74.0	54.0	-45.6	*	188	1.2
2414.86	-32.18	28.03	32.9	*	28.7	*	74.0	54.0	-45.3	*	16	1.2
2488.45	-32.18	28.18	32.6	*	28.6	*	74.0	54.0	-45.4	*	173	1.2

Antenna Polarization : Vertical

Frequency (MHz)	Cable Loss (dB)	Ant. Fact. (dB)	Reading (dBUV)		Emission (dBUV/m)		Limit Line (dBUV/m)		Margin (dBUV/m)		AZ (o)	EL (m)
			PK	AV	PK	AV	PK	AV	PK	AV		
2466.00	-32.21	28.13	61.7	46.8	57.6	42.7	74.0	54.0	-16.4	-11.3	245	1.2
4932.00	-30.24	33.75	36.9	*	40.4	*	74.0	54.0	-33.6	*	227	1.1
7398.00	-28.93	36.42	36.1	*	43.6	*	74.0	54.0	-30.4	*	132	1.3
2444.54	-32.23	28.09	34.9	*	30.8	*	74.0	54.0	-43.2	*	43	1.4
2475.78	-32.20	28.15	33.5	*	29.5	*	74.0	54.0	-44.5	*	256	1.6
2491.63	-32.17	28.18	34.1	*	30.1	*	74.0	54.0	-43.9	*	187	1.5

- NOTE :**
1. Measurement uncertainty is less than +/-2dB
  2. "\*": Measurement does not apply for this frequency.
  3. Emission Level = Reading Value + Ant. Factor + Cable Loss(included Pre-amplifier)
  4. The field strength of other emission frequencies were very low against the limit.
  5. The tested value of over 10GHz is too weak to record.

 <b>Spectrum Research &amp; Testing Lab., Inc.</b> No. 101-10, Ling 8, Shan-Tong Li, Chung-Li City, Taoyuan, Taiwan, R.O.C.	<h1>TEST REPORT</h1>	Reference No.: A07112106 Report No.: FCCA07112106 FCC ID: HQXAGP-Y6 Page:25 of 48 Date: Nov. 29, 2007
--	----------------------	---

## 6. 6 dB Bandwidth

### 6.1 LIMIT

Frequency Range (MHz)	Min. Limit (kHz)
2400 ~ 2483.5	500

### 6.2 TEST EQUIPMENT

The following test equipment was used during the test:

EQUIPMENT/ FACILITIES	SPECIFICATIONS	MANUFACTURER	MODEL#/ SERIAL#	DUE DATE OF CAL. & CAL. CENTER
SPECTRUM	9kHz-7GHz	ROHDE & SCHWARZ	FSP7/ 839511/010	APR. 2008 R&S

**NOTE:** The calibration interval of the above test equipment is one year and the calibrations are traceable to NML/ROC and NIST/USA.

### 6.3 TEST SET-UP

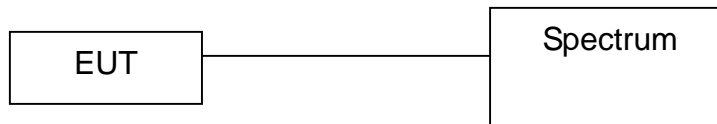

The EUT was connected to a spectrum through a 50Ω RF cable.

### 6.4 TEST PROCEDURE

The EUT was operating in hopping mode or could be controlled its channel. Printed out the test result from the spectrum by hard copy function.

### 6.5 EUT OPERATING CONDITION

Same as section 4.5 of this report.



**Spectrum Research & Testing Lab., Inc.**

No. 101-10, Ling 8,  
Shan-Tong Li, Chung-Li  
City, Taoyuan, Taiwan,  
R.O.C.

# TEST REPORT

Reference No.: A07112106  
Report No.: FCCA07112106  
FCC ID: HQXAGP-Y6  
Page:26 of 48  
Date: Nov. 29, 2007

## 6.6 TEST RESULT

Temperature:	26°C	Humidity:	57%RH
Spectrum Detector:	PK	Tested by:	Tim Mie
Test Result:	PASS	Tested Date:	Nov. 28, 2007

CHANNEL NUMBER	CHANNEL FREQUENCY (MHz)	6dB DOWN BW (kHz)
1	2414	548
3	2462	552
4	2466	580

Ch 1

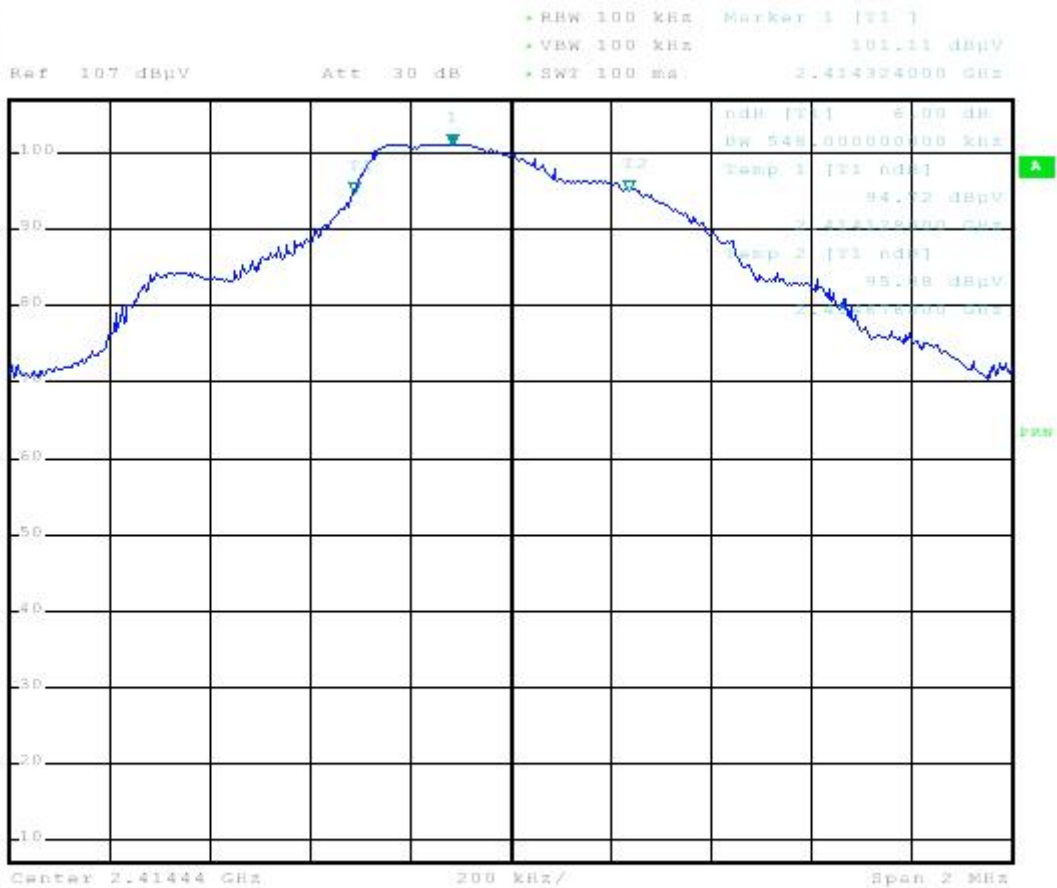



### Ch 3

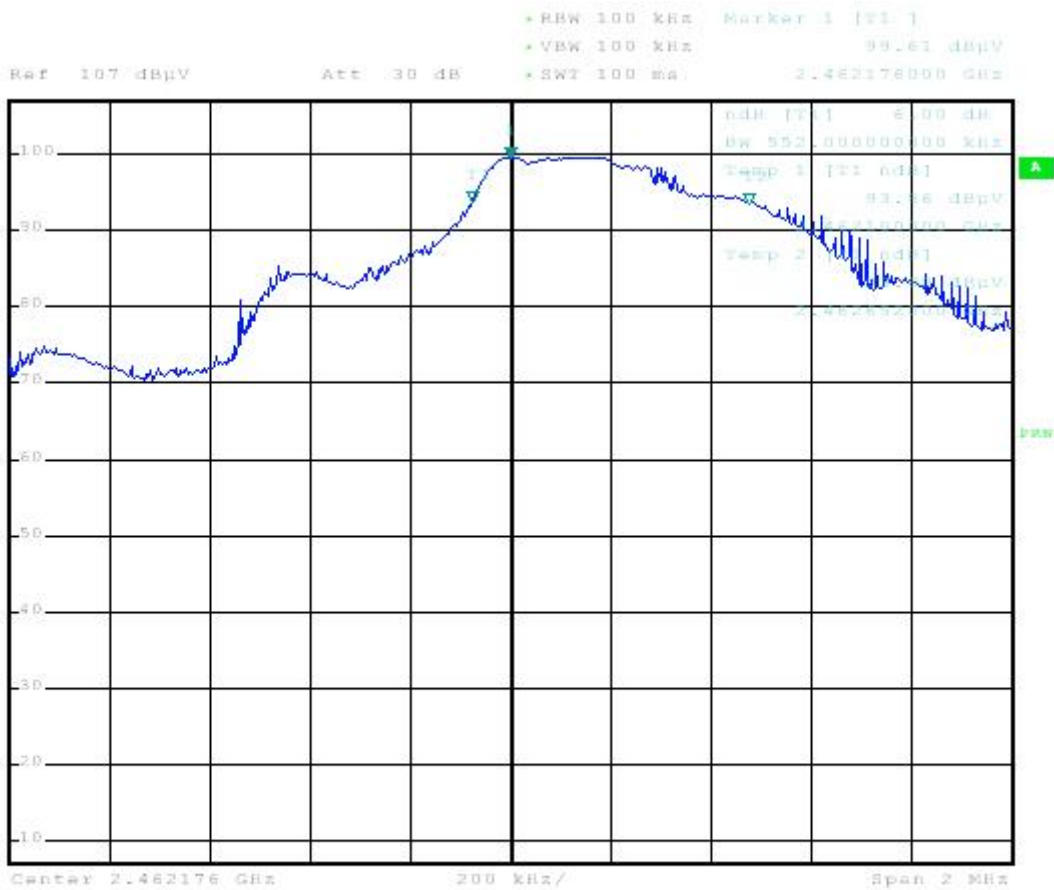



**Spectrum Research & Testing Lab., Inc.**  
 No. 101-10, Ling 8,  
 Shan-Tong Li, Chung-Li  
 City, Taoyuan, Taiwan,  
 R.O.C.

# TEST REPORT

Reference No.: A07112106  
 Report No.: FCCA07112106  
 FCC ID: HQXAGP-Y6  
 Page:28 of 48  
 Date: Nov. 29, 2007

Ch 4

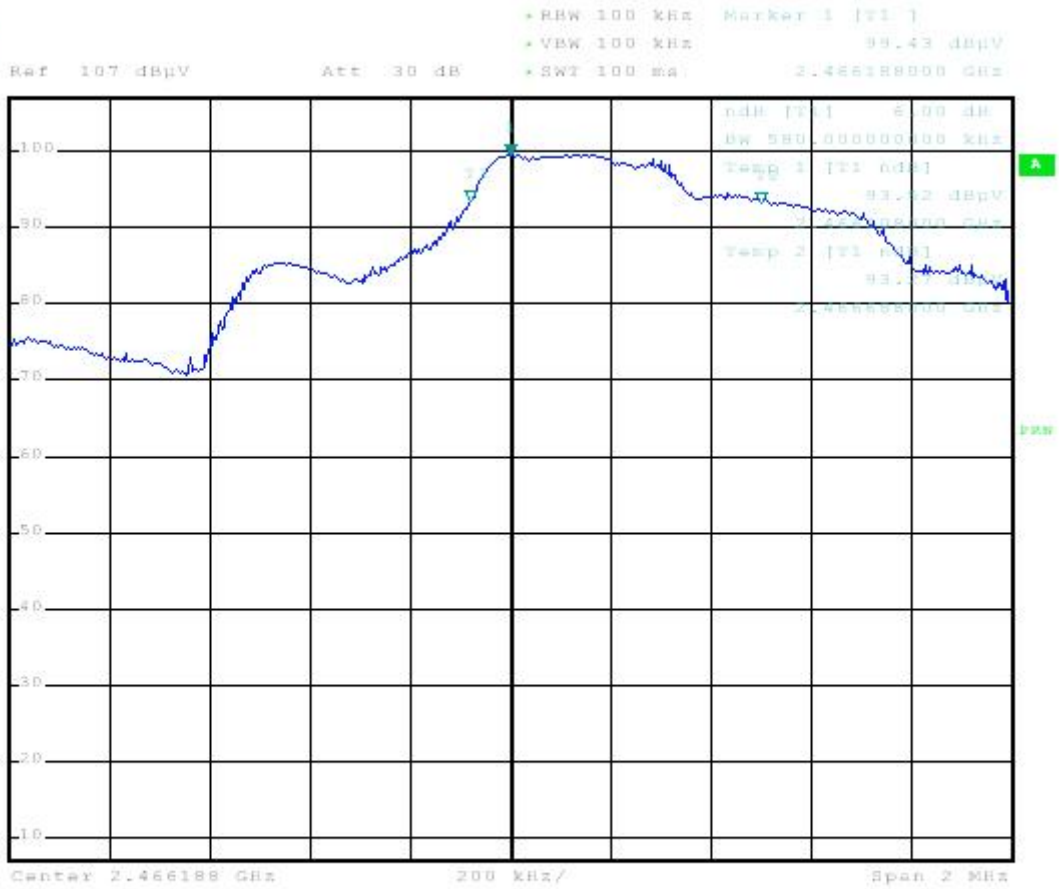

**Spectrum Research & Testing Lab., Inc.**No. 101-10, Ling 8,  
Shan-Tong Li, Chung-Li  
City, Taoyuan, Taiwan,  
R.O.C.**TEST REPORT**Reference No.: A07112106  
Report No.: FCCA07112106  
FCC ID: HQXAGP-Y6  
Page:29 of 48  
Date: Nov. 29, 2007**7. PEAK POWER TEST****7.1 LIMIT**

FCC Part15, Subpart C Section 15.247.

Frequency Range (MHz)	Limit(w)				
	Quantity of Hopping Channel	50	25	15	75
902-928		1(30dBm)	0.125(21dBm)	NA	NA
2400-2483.5		NA	NA	0.125(21dBm)	1(30dBm)
5725-5850		NA	NA	NA	1(30dBm)

**7.2 TEST EQUIPMENT**

The following test equipment was used during the test :

Equipment/Facilities	Specifications	Manufacturer	Model#/Serial#	Due Date of Cal. & Cal. Center
SPECTRUM	9kHz-7GHz	ROHDE & SCHWARZ	FSP7/ 839511/010	MAR. 2008 ETC
POWER METER	N/A	BOONTON	4232A/ 29001	MAY 2008 ETC
POWER SENSOR	DC-18GHz 0.3 $\mu$ W-100mW 50 $\Omega$	BOONTON	51011-EMC/ 31184	JUN. 2008 ETC

**NOTE:** The calibration interval of the above test equipment is one year and the calibrations are traceable to NML/ROC and NIST/USA.



### 7.3 TEST SET-UP

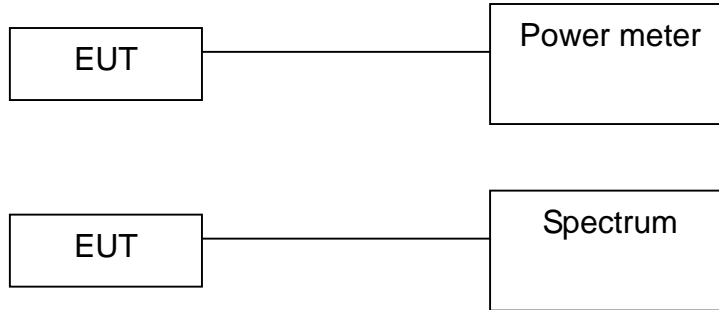

The EUT was connected to a spectrum through a 50Ω RF cable.

### 7.4 TEST PROCEDURE

The EUT could control its channel.

Printed out the test result from the spectrum by hard copy function.

Recorded the read value of the power meter.

### 7.5 EUT OPERATING CONDITION

Same as section 4.5 of this report.

### 7.6 TEST RESULT

Temperature:	22°C	Humidity:	61%RH
Spectrum Detector:	PK	Tested by:	Tim Mie
Test Result:	PASS	Tested Date:	Nov. 28, 2007

Channel Number	Channel Frequency (MHz)	Peak Output Power (dBm)	Peak Power Limit (dBm)
1	2414.0000	-7.1	30
3	2462.0000	-6.51	30
4	2466.0000	-6.34	30

P.S dBm=dBuV-107



**Spectrum Research & Testing Lab., Inc.**

No. 101-10, Ling 8,  
Shan-Tong Li, Chung-Li  
City, Taoyuan, Taiwan,  
R.O.C.

# TEST REPORT

Reference No.: A07112106  
Report No.: FCCA07112106  
FCC ID: HQXAGP-Y6  
Page:31 of 48  
Date: Nov. 29, 2007

CH1

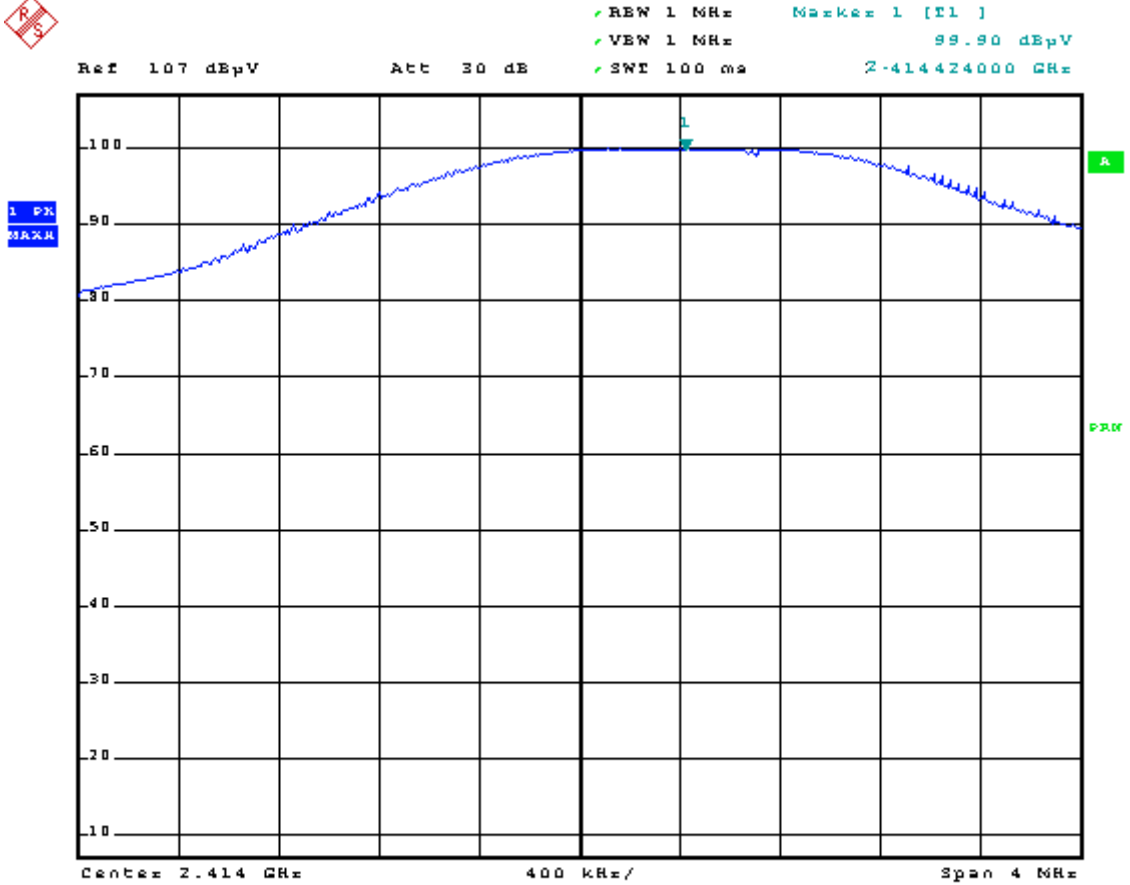



**Spectrum Research & Testing Lab., Inc.**

No. 101-10, Ling 8,  
Shan-Tong Li, Chung-Li  
City, Taoyuan, Taiwan,  
R.O.C.

# TEST REPORT

Reference No.: A07112106  
Report No.: FCCA07112106  
FCC ID: HQXAGP-Y6  
Page:32 of 48  
Date: Nov. 29, 2007

CH3

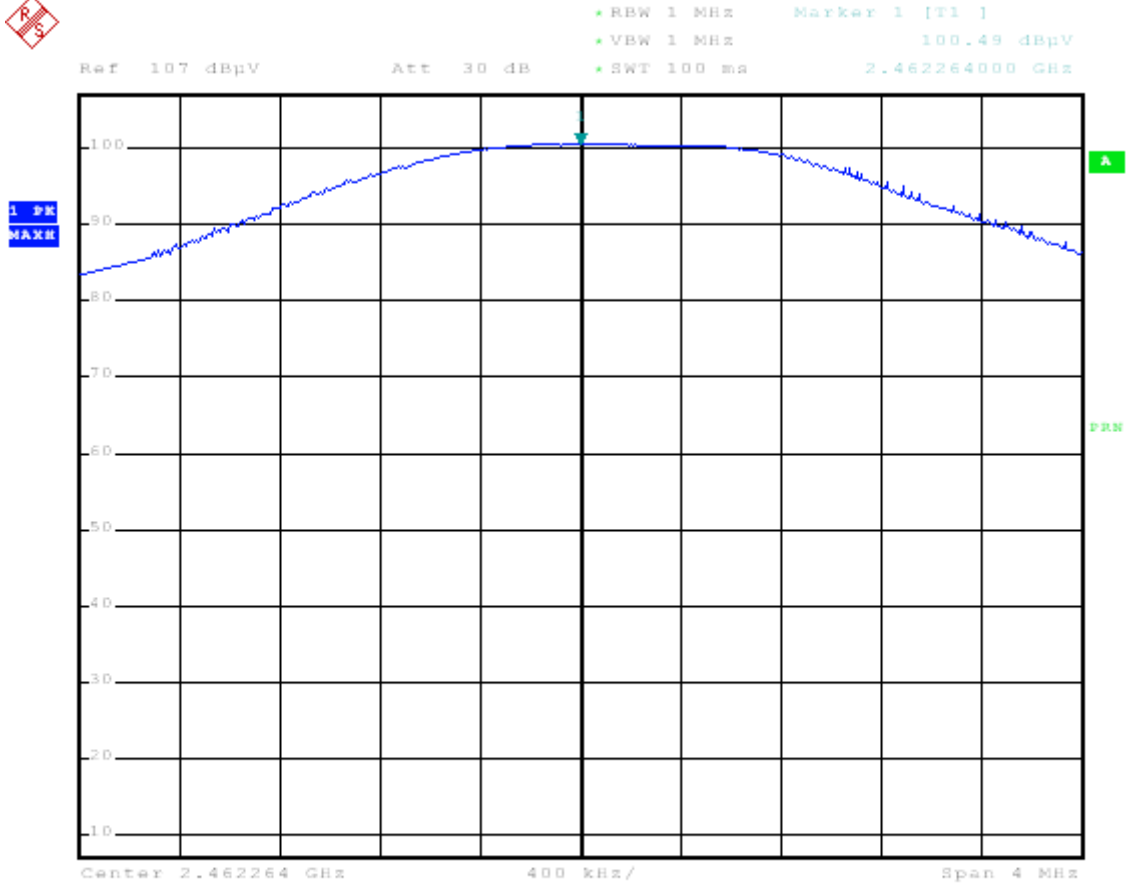



**Spectrum Research & Testing Lab., Inc.**

No. 101-10, Ling 8,  
Shan-Tong Li, Chung-Li  
City, Taoyuan, Taiwan,  
R.O.C.

# TEST REPORT

Reference No.: A07112106  
Report No.: FCCA07112106  
FCC ID: HQXAGP-Y6  
Page:33 of 48  
Date: Nov. 29, 2007

CH4

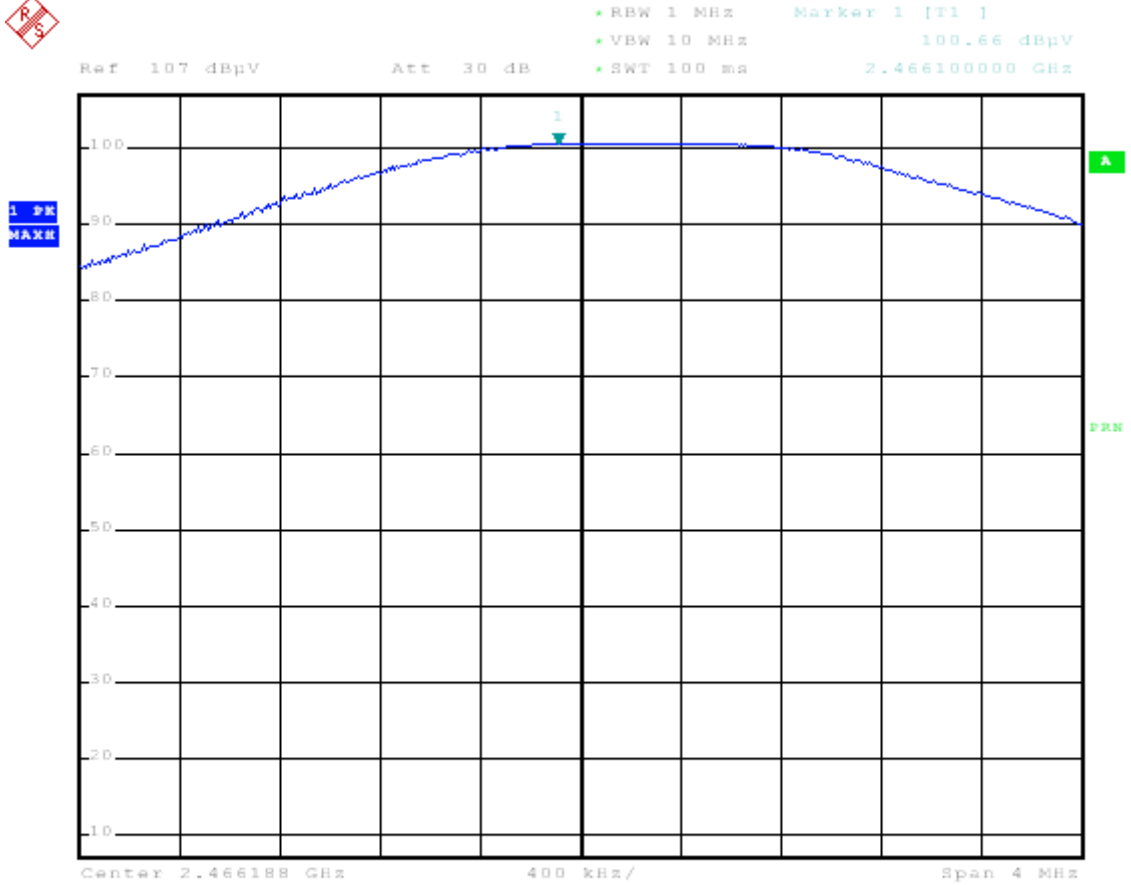



## 8. BAND EDGE TEST

### 8.1 LIMIT

FCC Part15, Subpart C Section 15.247(d). In any 100 kHz bandwidth outside the frequency band in which the spread spectrum intentional radiator is operating, the radio frequency power that is produced by the intentional radiator shall be at least 20 dB below that in the 100 kHz bandwidth within the band that contains the highest level of the desired power, based on either an RF conducted or a radiated measurement. Attenuation below the general limits specified in Section 15.209(a) is not required. In addition, radiated emissions which fall in the restricted bands, as defined in Section 15.205(a), must also comply with the radiated emission limits specified in Section 15.209(a) (see Section 15.205(c)).

OPERATING FREQUENCY RANGE (MHz)	SPURIOUS EMISSION FREQUENCY (MHz)	LIMIT	
		Peak power ration to emission(dBc)	Emission level(dBuV/m)
902-928	<902	>20	NA
	>928	>20	NA
	960-1240	NA	54
2400-2483.5	<2400	>20	NA
	>2483.5-2500	NA	54
5725-5850	<5350-5460	NA	54
	<5725	>20	NA
	>5850	>20	NA

**Spectrum Research  
& Testing Lab., Inc.**No. 101-10, Ling 8,  
Shan-Tong Li, Chung-Li  
City, Taoyuan, Taiwan,  
R.O.C.**TEST REPORT**Reference No.: A07112106  
Report No.: FCCA07112106  
FCC ID: HQXAGP-Y6  
Page:35 of 48  
Date: Nov. 29, 2007**8.2 TEST EQUIPMENT**

The following test equipment was used during the test :

Equipment/ Facilities	Specification	Manufacturer	Model#/ Serial#	Due Date of Cal. & Cal. Center
SPECTRUM	9kHz-7GHz	ROHDE & SCHWARZ	FSP7/ 839511/010	APR. 2008 R&S
EMI TEST RECEIVER	9 kHz TO 2750 MHz	ROHDE & SCHWARZ	ESCS30/ 830245/012	OCT. 2008 ETC
SPECTRUM	9KHz-26.5GHz	HP	8953E/ 3710A03220	MAY 2008 ETC
PRE-AMPLIFIER	1GHz-26.5GHz Gain:30dB	HP	8449B/ 3008A01019	NOV. 2008 ETC
BI-LOG ANTENNA	25 MHz TO 2 GHz	EMCO	3142/ 9701-1124	FEB. 2008 SRT
HORN ANTENNA	1GHz to 18GHz	EMCO	3115/ 9602-4681	DEC. 2008 ETC
OATS	3 - 10 M measurement	SRT	SRT-1	APR. 2008 SRT

**NOTE:** The calibration interval of the above test equipment is one year and the calibrations are traceable to NML/ROC and NIST/USA.



## 8.3 TEST SET-UP

FOR RF CONDUCTED TEST (dBc)

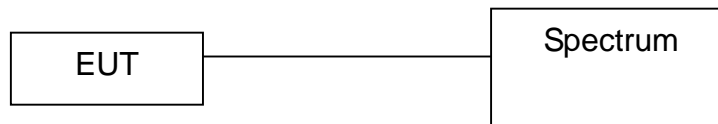

The EUT was connected to the spectrum through a 50 $\Omega$  RF cable.

FOR RADIATED EMISSION TEST

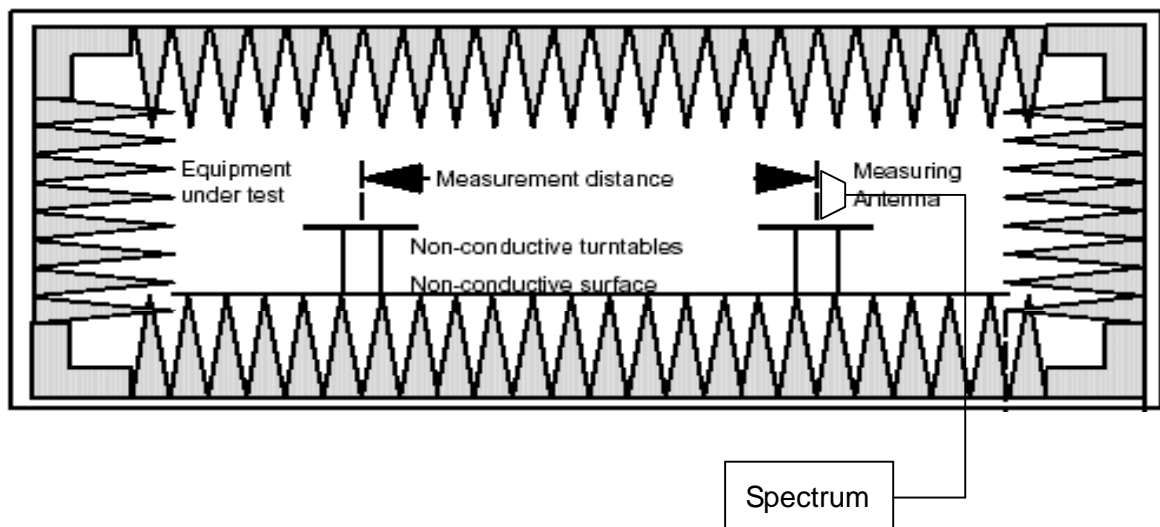

**NOTE :**

1. The EUT system was put on a wooden table with 0.8m heights above a ground plane.
2. For the actual test configuration, please refer to the photos of testing.





## 8.4 TEST PROCEDURE

1. The EUT could be controlled its channel.  
Printed out the test result from the spectrum by hard copy function.
2. The EUT was tested according to the requirement of ANSI C63.4 , CISPR 22/ RSS-Gen. The measurements were made at an open area test site with 10 meter measurement distance under 1 GHz and with 3m distance above 1GHz. The frequency spectrum measured started from 30 MHz. Under 1 GHz. All readings were quasi-peak values with 120 kHz resolution bandwidth of the test receiver. Above 1 GHz, the measurements were made at an open area test site with 3 meter measurement distance and all readings were peak and average values with 1 MHz resolution bandwidth of the test receiver. The EUT system was operated in all typical methods by users. The cables connected to EUT and support units were moved to find the maximum emission levels for each frequency.

## 8.5 EUT OPERATING CONDITION

Same as section 4.5 of this report.

## 8.6 TEST RESULT

Temperature:	23°C	Humidity:	66%RH
Spectrum Detector:	PK & AV	Tested by:	Tim Mie
Test Result:	PASS	Tested Date:	Nov. 28, 2007

### 1. Conducted emission test

Frequency (MHz)	PEAK POWER OUTPUT (dBuV)	Emission read Value(dBuV)	Result of Band edge (dBc)	Band edge LIMIT (dBc)
<2400	97.3	72.97	24.33	>20dBc
>2483.5	100.23	74.39	25.84	>20dBc

### 2. Radiated emission test

Frequency (MHz)	Antenna polarization (H/V)	Reading (dBuV)	Emission (dBuV/)	Band edge Limit (dBuV)
		Strength	Strength	Strength
<2400	H	46.2	42.0	54.0
>2483.5	V	47.0	42.9	54.0



**Spectrum Research & Testing Lab., Inc.**

No. 101-10, Ling 8,  
Shan-Tong Li, Chung-Li  
City, Taoyuan, Taiwan,  
R.O.C.

# TEST REPORT

Reference No.: A07112106  
Report No.: FCCA07112106  
FCC ID: HQXAGP-Y6  
Page:38 of 48  
Date: Nov. 29, 2007

<2400 MHz(Conducted)

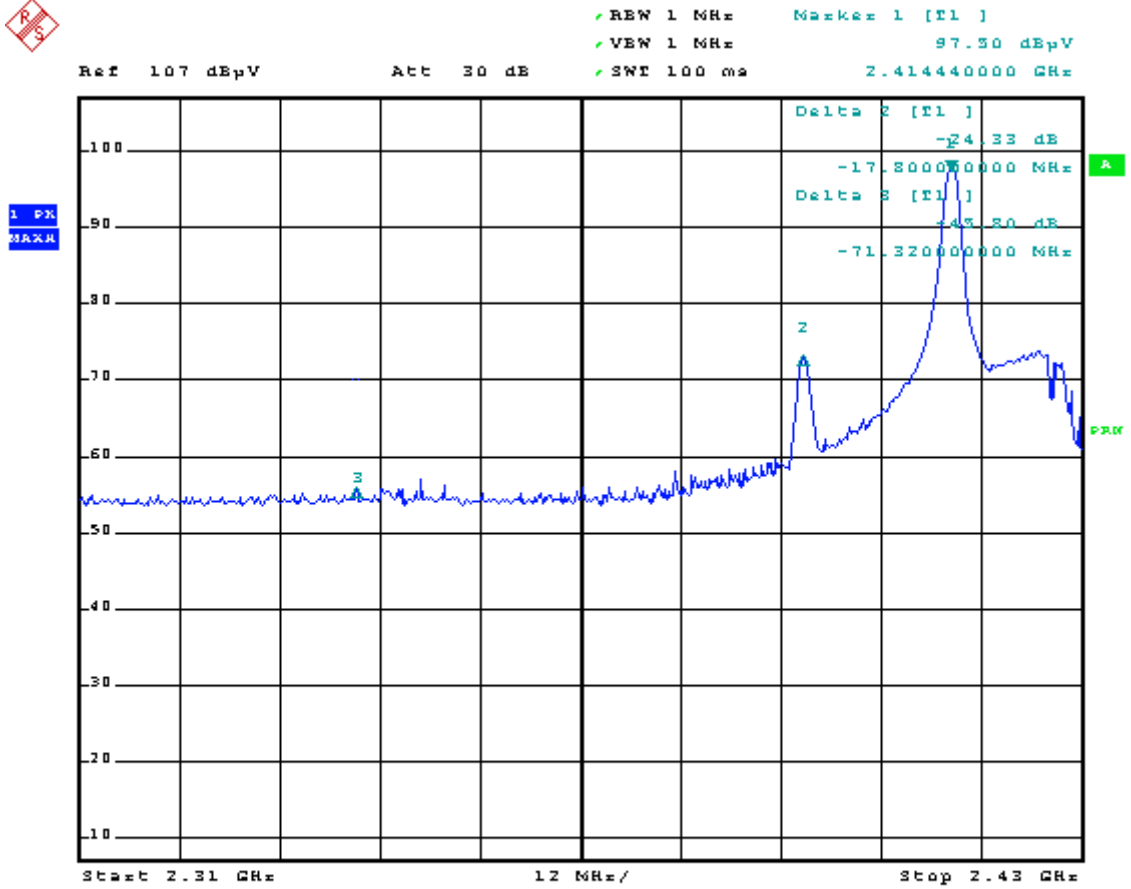



**Spectrum Research & Testing Lab., Inc.**

No. 101-10, Ling 8,  
Shan-Tong Li, Chung-Li  
City, Taoyuan, Taiwan,  
R.O.C.

# TEST REPORT

Reference No.: A07112106  
Report No.: FCCA07112106  
FCC ID: HQXAGP-Y6  
Page:39 of 48  
Date: Nov. 29, 2007

>2483.5 MHz(Conducted)



Ref 107 dBpV      Att 30 dB      ✓ RBW 1 MHz      Marker 1 [F1 ]  
✓ VBW 1 MHz      100.23 dBpV  
✓ SWT 100 ms      2.462340000 GHz

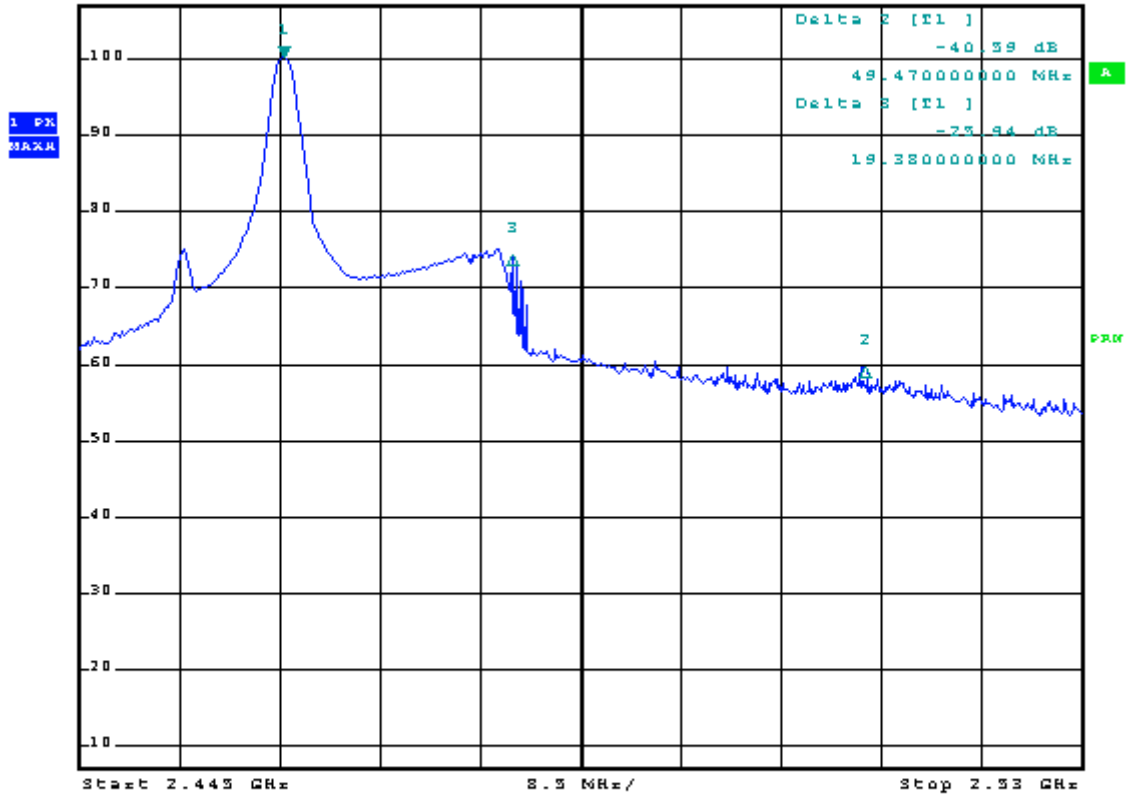

## 9. POWER DENSITY TEST

### 9.1 LIMIT

FCC Part15, Subpart C section15.247

Frequency Range (MHz)	Limit (dBm/kHz)
902-928	8dBm/3kHz
2400-2483.5	
5725-5850	

### 9.2 TEST EQUIPMENT

The following test equipment was used during the radiated emission test:

EQUIPMENT/FACILITIES	SPECIFICATIONS	MANUFACTURER	MODEL#/SERIAL#	DUE DATE OF CAL. & CAL. CENTER
SPECTRUM	9 kHz-7GHz	ROHDE & SCHWARZ	FSP7/ 839511/010	MAR. 2008 R & S

**NOTE:** The calibration interval of the above test equipment is one year and the calibrations are traceable to NML/ROC and NIST/USA.

### 9.3 TEST SET-UP

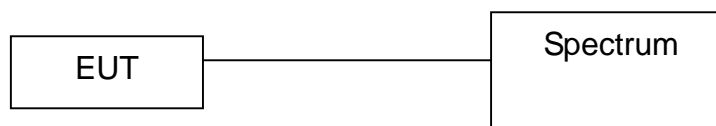

The EUT was connected to a spectrum through a 50Ω RF cable.

### 9.4 TEST PROCEDURE

The EUT was operating in transmitter mode and could be controlled its channel. Printed out the test result from the spectrum by hard copy function.

### 9.5 EUT OPERATING CONDITION

Same as section 4.5 of this report.



**Spectrum Research & Testing Lab., Inc.**  
 No. 101-10, Ling 8,  
 Shan-Tong Li, Chung-Li  
 City, Taoyuan, Taiwan,  
 R.O.C.

# TEST REPORT

Reference No.: A07112106  
 Report No.: FCCA07112106  
 FCC ID: HQXAGP-Y6  
 Page:41 of 48  
 Date: Nov. 29, 2007

## 9.6 TEST RESULT

Temperature:	<u>23°C</u>	Humidity:	<u>66%RH</u>
Spectrum Detector:	<u>PK.</u>	Tested By:	<u>Tim Mie</u>
Tested Result:	<u>Pass</u>	Tested Date:	<u>Nov. 28, 2007</u>

Channel Number	Channel Frequency (MHz)	RF POWER LEVEL IN 3kHz BW (dBm/3kHz)	MAXIMUM Limit (dBm/3kHz)
1	2414.0000	-20.62	8
3	2462.0000	-19.62	8
4	2466.0000	-18.10	8

CH1

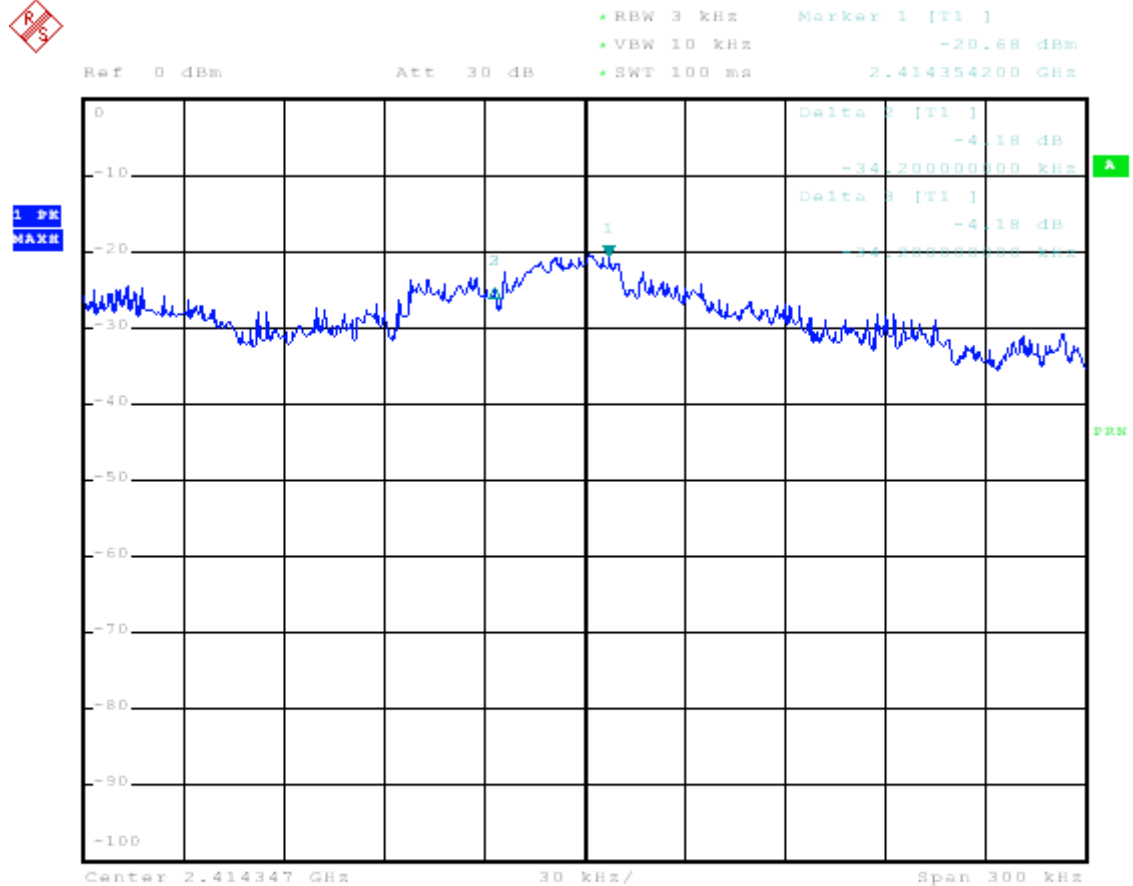



**Spectrum Research & Testing Lab., Inc.**

No. 101-10, Ling 8,  
Shan-Tong Li, Chung-Li  
City, Taoyuan, Taiwan,  
R.O.C.

# TEST REPORT

Reference No.: A07112106  
Report No.: FCCA07112106  
FCC ID: HQXAGP-Y6  
Page:42 of 48  
Date: Nov. 29, 2007

CH3

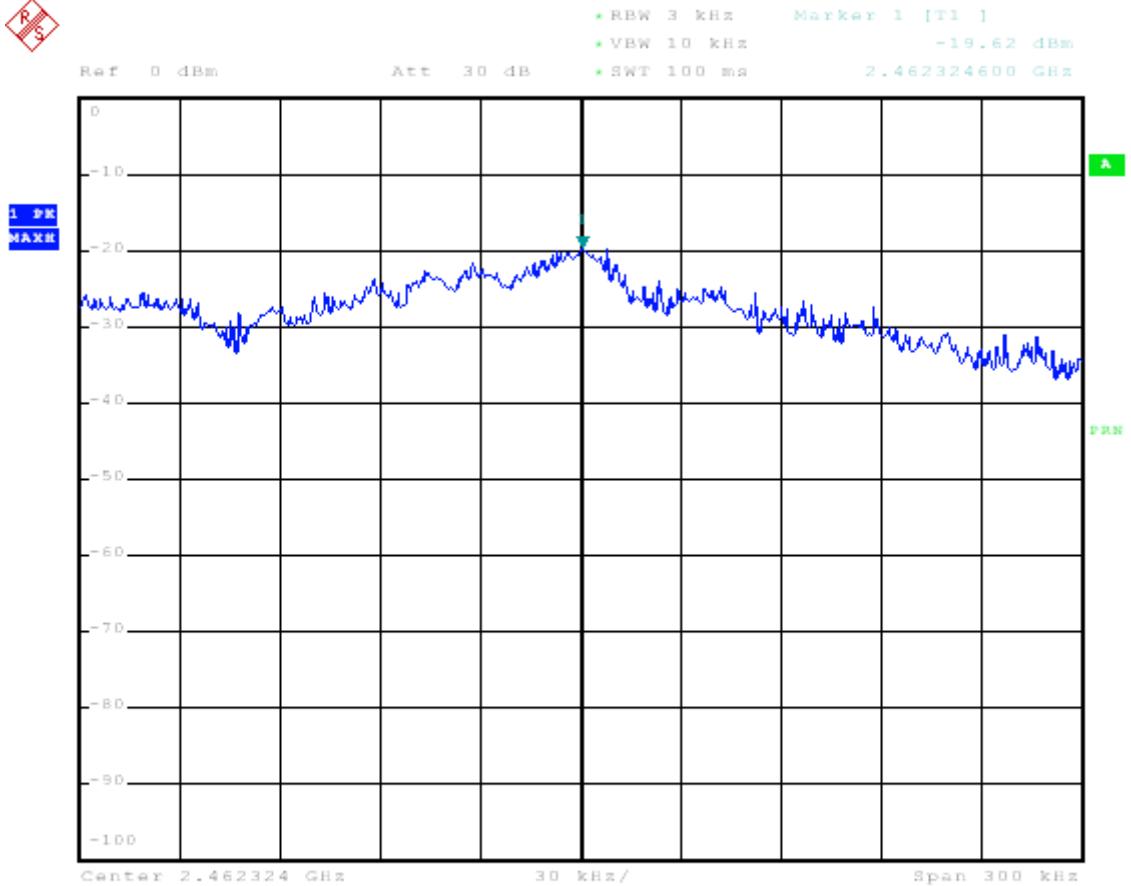



**Spectrum Research & Testing Lab., Inc.**

No. 101-10, Ling 8,  
Shan-Tong Li, Chung-Li  
City, Taoyuan, Taiwan,  
R.O.C.

# TEST REPORT

Reference No.: A07112106  
Report No.: FCCA07112106  
FCC ID: HQXAGP-Y6  
Page:43 of 48  
Date: Nov. 29, 2007

CH4

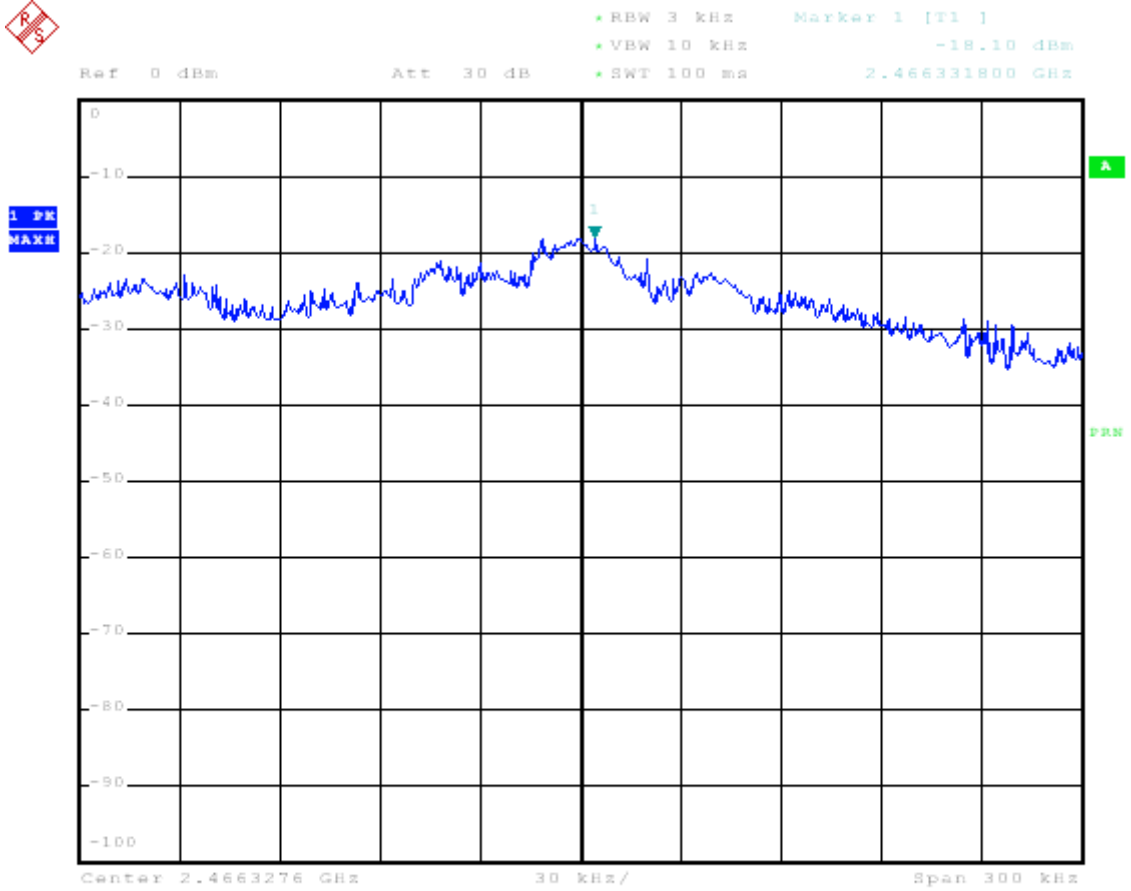



**Spectrum Research  
& Testing Lab., Inc.**

No. 101-10, Ling 8,  
Shan-Tong Li, Chung-Li  
City, Taoyuan, Taiwan,  
R.O.C.

# TEST REPORT

Reference No.: A07112106  
Report No.: FCCA07112106  
FCC ID: HQXAGP-Y6  
Page:44 of 48  
Date: Nov. 29, 2007

## 10. ANTENNA APPLICATION

### 10.1 Antenna requirement

The EUT's antenna is met the requirement of FCC part15C section15.203 and 15.204.

FCC part15C section15.247 requirement:

Systems operating in the 2400-2483.5 MHz band that are used exclusively for fixed, point-to-point operations may employ transmitting antennas with directional gain greater than 6 dBi provided the maximum peak output power of the intentional radiator is reduced by 1 dB for every 3 dB that the directional gain of the antenna exceeds 6 dBi.

### 10.2 Result

The EUT's antenna used a PCB antenna. The antennas' gain is 0dBi and meet the requirement.



**Spectrum Research  
& Testing Lab., Inc.**

No. 101-10, Ling 8,  
Shan-Tong Li, Chung-Li  
City, Taoyuan, Taiwan,  
R.O.C.

# TEST REPORT

Reference No.: A07112106  
Report No.: FCCA07112106  
FCC ID: HQXAGP-Y6  
Page:48 of 48  
Date: Nov. 29, 2007

## 12. TERMS OF ABBREVIATION

AV.	Average detection
AZ(°)	Turn table azimuth
Correct.	Correction
EL(m)	Antenna height (meter)
EUT	Equipment Under Test
Horiz.	Horizontal direction
LISN	Line Impedance Stabilization Network
NSA	Normalized Site Attenuation
Q.P.	Quasi-peak detection
SRT Lab	Spectrum Research & Testing Laboratory, Inc.
Vert.	Vertical direction