

2.4 GHz cordless mouse combination product user's manual

● This Packing Contains:

1. Cordless mouse 1 pcs.
2. Receiver 1 pcs .
3. AAA alkaline battery 2 pcs. (Use in mouse product)
4. User's manual.

● Mouse Product Function:

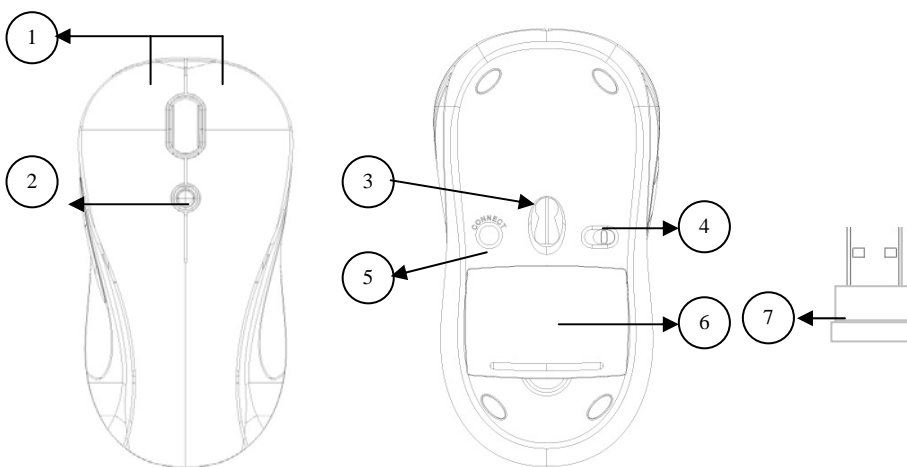

1. Left/right Button.

→ Press Left & right buttons simultaneously and hold down 3 seconds will switch mouse resolution.
(Switch from 800 to 1600 DPI, and press again to change from 1600 to 800 DPI).

2. Low power battery indicator.

→ The low power battery indicator to remind you to change the batteries when the red led light is sparking.

3. Optical Sensor.

4. Power on/off.

→ Power on/off switch to maximize battery life .

5. Mouse ID pairing button.

→ Connect the mouse and receiver ..

6. Battery case.

→ Open battery case and follow the remark(+, -) to put batteries correctly.

7. Receiver Led indicator.

→ It will be sparking while connecting mouse or data transfer.

● Product operation sequence.

※ When this product finished from factory, all has completed mouse and receiver pairing code!

Therefore please put batteries into the mouse battery case separately according to the correct polarity, then insert the receiver into computer USB port, then you can use the products..

If this product is unable to use! Please follow operation sequence to set the pairing code.

1. Insert the receiver into the USB port of computer, then press the receiver ID pairing button .Now LED of receiver start to sparking °
2. After 20 seconds, separately press ID pairing button of mouse, then finish pairing process.

● **Driver installation.**

1. Please uninstall other driver of mouse.
2. Insert the driver CD into the CD-ROM/DVD-ROM of your computer.
3. Follow the on-screen instructions.
4. Restart your computer.

● **System Requirements**

1. IBM PC or compatible systems with USB host connector °
2. Windows 2000/ME/XP/VISTA °

● **Federal Communication Commission Interference Statement**

This equipment has been tested and found to comply with the limits for a Class B digital device, pursuant to Part 15 of the FCC Rules. These limits are designed to provide reasonable protection against harmful interference in a residential installation. This equipment generates, uses and can radiate radio frequency energy and, if not installed and used in accordance with the instructions, may cause harmful interference to radio communications. However, there is no guarantee that interference will not occur in a particular installation. If this equipment does cause harmful interference to radio or television reception, which can be determined by turning the equipment off and on, the user is encouraged to try to correct the interference by one of the following measures:

- Reorient or relocate the receiving antenna.
- Increase the separation between the equipment and receiver.
- Connect the equipment into an outlet on a circuit different from that to which the receiver is connected.
- Consult the dealer or an experienced radio/TV technician for help.

FCC Caution: Any changes or modifications not expressly approved by the party responsible for compliance could void the user's authority to operate this equipment.

This device complies with Part 15 of the FCC Rules. Operation is subject to the following two conditions: (1) This device may not cause harmful interference, and (2) this device must accept any interference received, including interference that may cause undesired operation.

This device and its antenna(s) must not be co-located or operating in conjunction with any other antenna or transmitter.