

Intermec certifies that all antennas described in this exhibit will be sold with a unique antenna connector that meets the requirements of 47 CFR 15.203. Specifically, either reverse polarity TNC or reverse polarity N type connectors.

2.4 GHz antennas for the 802.11b radio

Intermec Part Number	Min. Freq. (GHz)	Max. Freq. (GHz)	Style	Max. Gain
063363	2.4	2.5	Omni	5 dBi
063365	2.4	2.5	Yagi	15 dBi
071122	2.4	2.5	Corner Reflector	9 dBi
065349	2.4	2.5	Omni	9 dBi
066147	2.4	2.5	Omni	1 dBi
067261	2.4	2.5	Mini Omni	3 dBi
067262	2.4	2.5	Flat Panel	5 dBi
067263	2.4	2.5	Flat Panel	9 dBi

7

6

5

4

3

2

1

APPROVED SOURCE(S) OF SUPPLY

SUPPLIER	PART NUMBER
1. CUSHCRAFT	S2403BP12RNF 7
2.	
3.	
4.	
5.	
6.	

REVISION		REV STATUS OF SHEETS	REVISIONS		
REV	DESCRIPTION	DATE	DRAWN & APPROVED		
C	-001 RELEASED AT REV C				
D	-001 PER ECN 025344	8-27-96	G.OPSTAD	RCH	

D

D

C

C

B

B

A

A

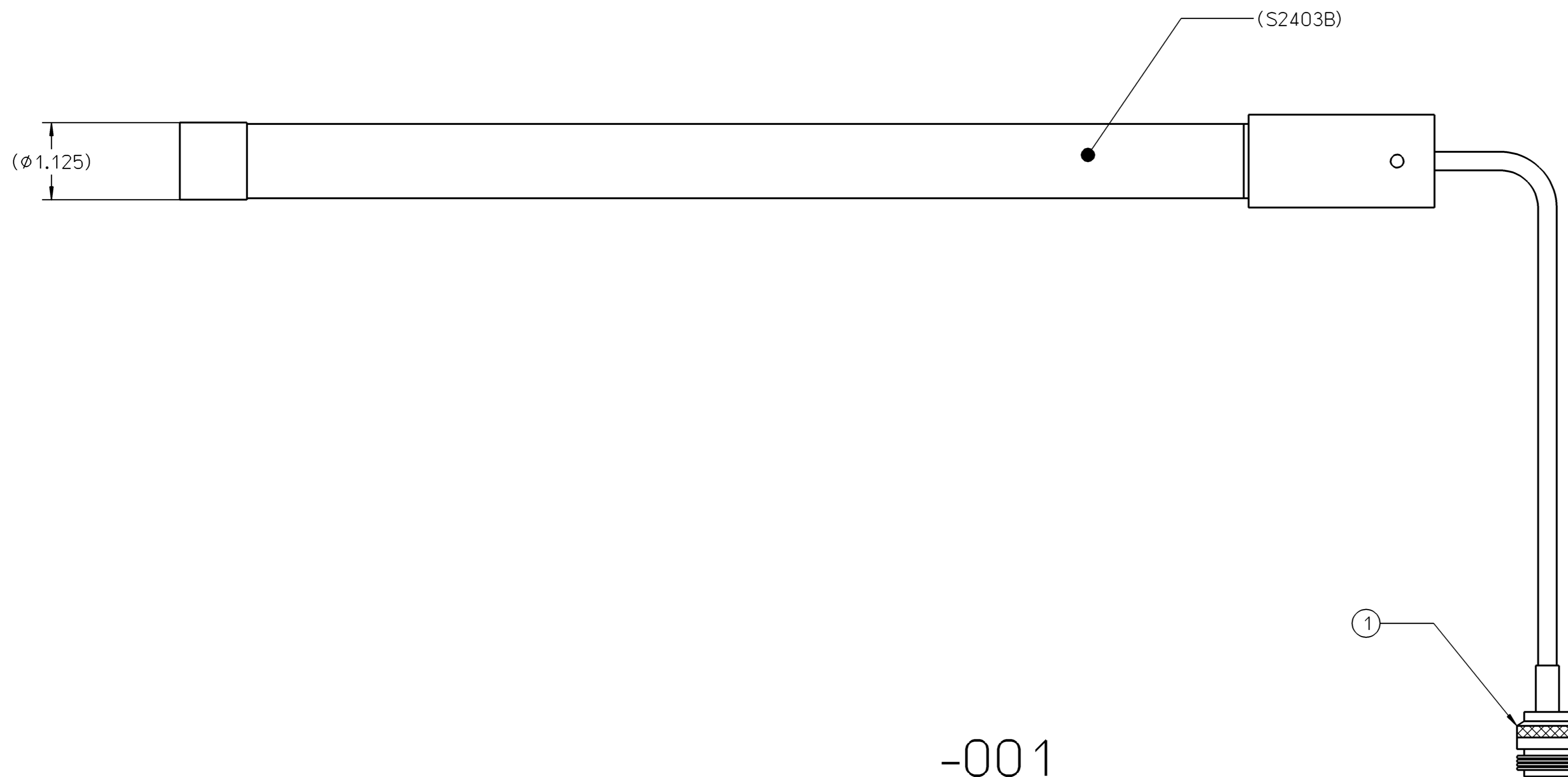

-001

- NOTES: UNLESS OTHERWISE SPECIFIED
- MATERIAL: POLYCARBONATE.
 - REMOVE ALL BURRS AND SHARP EDGES.
 - COSMETIC REQUIREMENTS PER SPECIFICATION 044856, APPENDIX C, CATEGORY II, CLASS B.
 - BAG PARTS AND MARK BAG WITH 063363 PER SPECIFICATION 606427. DO NOT MARK DASH NUMBER.
 - CHANGES REQUIRE SAC APPROVAL.
 - SPECIFICATION:
 FREQUENCY RANGE: 2400-2500MHz
 IMPEDANCE: 50 OHMS (NOMINAL)
 GAIN: 3dBd (REFERENCED TO DIPOLE)
 5dBi (REFERENCED TO ISOTROPIC)
 BANDWIDTH: 100MHz (VWSR <= 1.5:1)
 VSWR: <= 1.5:1 (2400-2500MHz)
 WIND SURVIVAL: 125MPH
 POWER RATING: 50 WATTS MAX
- 7 MOUNTING HARDWARE KIT AND INSTRUCTIONS INCLUDED.

SOURCE CONTROL DRAWING SEE SEPARATE PARTS LIST FOR 063363-001

NOTICE
 THIS DRAWING SHALL NOT BE DUPLICATED OR USED FOR ANY PURPOSE OTHER THAN THAT FOR WHICH PROVIDED. THE INFORMATION DISCLOSED HEREIN ORIGINATED BY AND IS THE PROPERTY OF INTERMEC CORPORATION AND EXCEPT FOR RIGHTS EXPRESSLY GRANTED BY WRITTEN CONSENT, SUCH INFORMATION SHALL NOT BE DISCLOSED OR DISSEMINATED WHOLE OR IN PART. INTERMEC CORPORATION RESERVES ALL PATENT, PROPRIETARY, DESIGN, USE, SALE, MANUFACTURING AND REPRODUCTION RIGHTS THERETO.

CAD DB.REF- /cadserv/rel/063363.1.d		SYSTEM - HP-ME30		UNLESS OTHERWISE SPECIFIED, DIMENSIONS ARE IN INCHES.		APPROVALS		DATE		Intermec 6001 36TH AVENUE WEST EVERETT, WA 98203-9280	
DRAWN		J.FOTI		1-19-96		CHECKEDR.HOAGLUND		1-23-96		TITLE	
RESP ENG		M.CHIN		1-23-96		QA		T.ANDERSON		ANTENNA, 2.4GHZ, OMNI	
MFG ENG		M.SALATINO		1-22-96		SAC		P.HELTON		DRAWING NUMBER	
CMPNT ENG						SIZE		CAGE CODE		DRAWING NUMBER	
						D		33825		063363	
						SCALE		NONE		SHEET 1 OF 1	

7

6

5

4

3

2

1

7

6

5

4

3

2

1

APPROVED SOURCE(S) OF SUPPLY

SUPPLIER	PART NUMBER
1. CUSHCRAFT	PC-2415RNF
2.	
3.	
4.	
5.	
6.	

REVISION					REV STATUS	REVISIONS			
5	4	3	2	1	OF SHEETS	REV	DESCRIPTION	DATE	DRAWN & APPROVED
					SHEET	C	-001 RELEASED AT REV C		
						D	-001 PER ECN 025344	9-3-96	L.JACKSON RCH

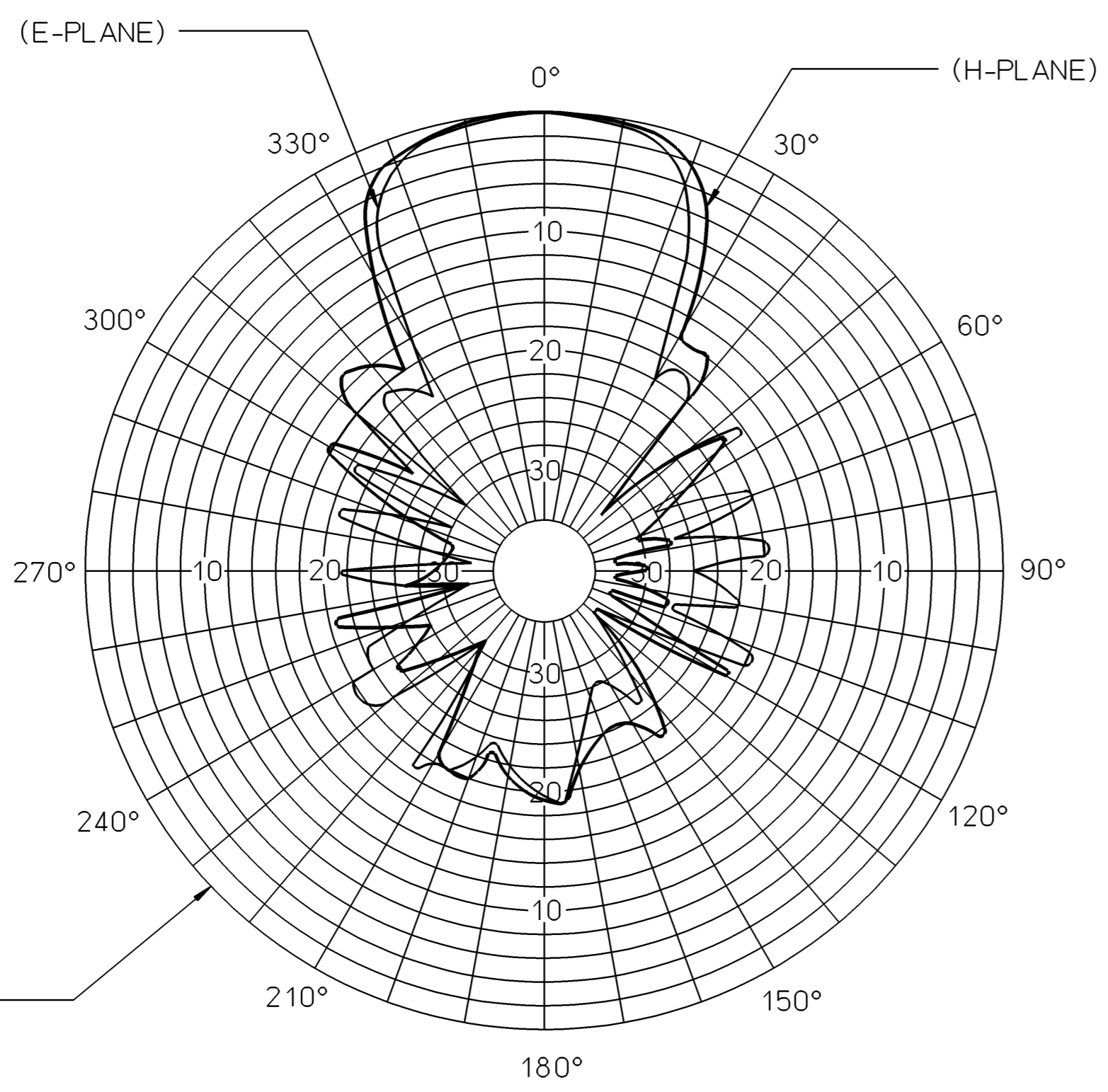
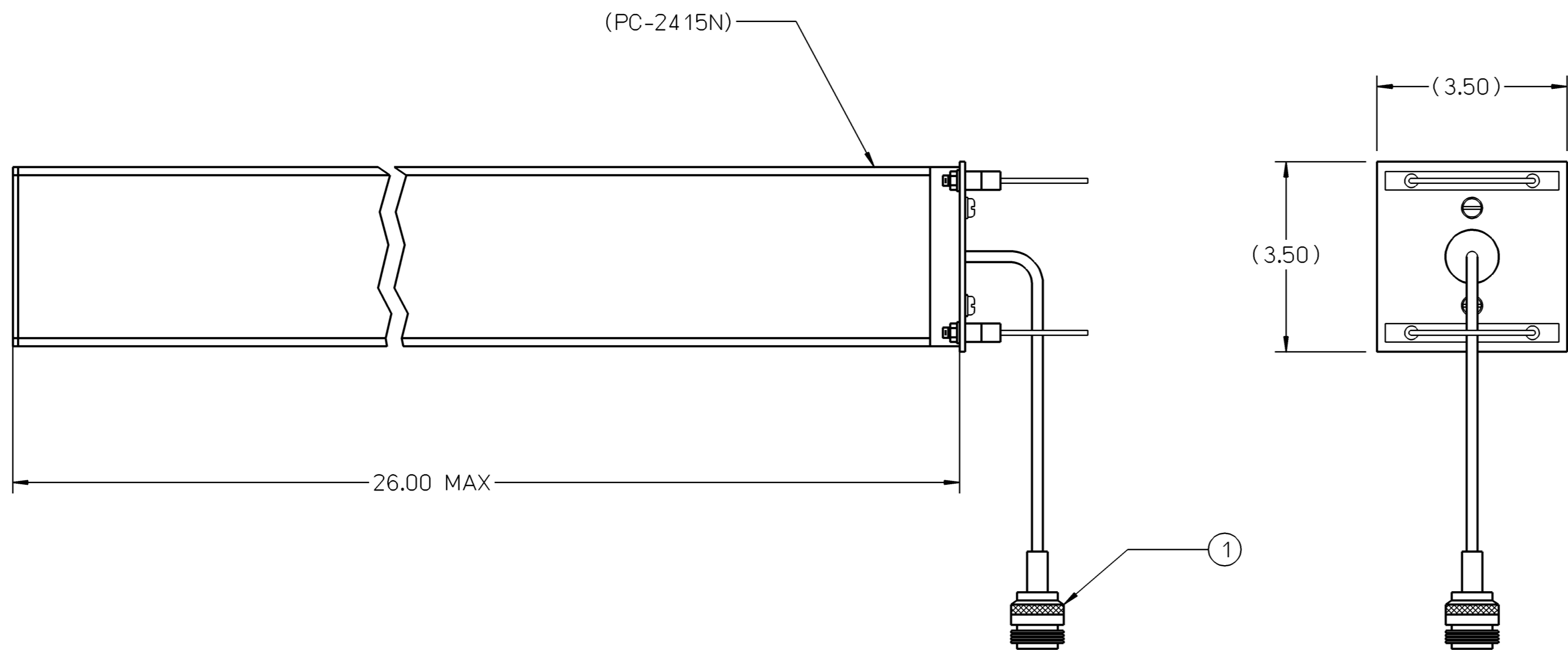

NOTES: UNLESS OTHERWISE SPECIFIED

- MATERIAL: LEXAN RADOME AND STAINLESS STEEL MOUNTING HARDWARE.
- COLOR: NEUTRAL.
- REMOVE ALL BURRS AND SHARP EDGES.
- COSMETIC REQUIREMENTS PER SPECIFICATION 044856, APPENDIX C, CATEGORY II, CLASS B.
- BAG PARTS AND MARK BAG WITH 063365 PER SPECIFICATION 606427. DO NOT MARK DASH NUMBER.
- CHANGES REQUIRE SAC APPROVAL.
- SPECIFICATION:
 FREQUENCY RANGE: 2400-2500MHz
 IMPEDANCE: 50 ohms (NOMINAL)
 GAIN: 13dBd (REFERENCED TO DIPOLE)
 15dBi (REFERENCED TO ISOTROPIC)
 BEAMWIDTH (3dB) H-PLANE: 34 DEGREES
 E-PLANE: 30 DEGREES
 FRONT TO BACK RATIO: > 17dB
 BANDWIDTH: 100MHz (VWSR<=2:1)
 VSWR: <=2:1 (2400-2500MHz)
 NUMBER OF ELEMENTS: 15
 POWER RATING: 200 WATTS MAX
 WEIGHT: < 1lb
 WIND LOAD: .4ft²
- DO NOT INSPECT PARTS TO DIAGRAM. FOR REFERENCE ONLY.
- MOUNTING HARDWARE KIT AND INSTRUCTIONS INCLUDED.

-001

SOURCE CONTROL DRAWING
SEE SEPARATE PARTS LIST FOR 063365-001

NOTICE
 THIS DRAWING SHALL NOT BE DUPLICATED OR USED FOR ANY PURPOSE OTHER THAN THAT FOR WHICH PROVIDED. THE INFORMATION DISCLOSED HEREIN ORIGINATED BY AND IS THE PROPERTY OF INTERMEC CORPORATION AND EXCEPT FOR RIGHTS EXPRESSLY GRANTED BY WRITTEN CONSENT, SUCH INFORMATION SHALL NOT BE DISCLOSED OR DISSEMINATED WHOLE OR IN PART. INTERMEC CORPORATION RESERVES ALL PATENT, PROPRIETARY, DESIGN, USE, SALE, MANUFACTURING AND REPRODUCTION RIGHTS THERETO.

CAD DB:REF- 063365.1.d SYSTEM - HP			
UNLESS OTHERWISE SPECIFIED, DIMENSIONS ARE IN INCHES.		APPROVALS	
.XX ±		DATE	
.XXX ±		DRAWN J.FOTI 8-22-95	
ANGLES ±		CHECKED R.HOAGLUND 1-19-96	
		RESP ENG M.CHIN 1-23-96	
		QA T.ANDERSON 1-23-96	
		MFG ENG M.SALATINO 1-22-96	
		SAC P.HELTON 1-22-96	
		CMPNT ENG _____	
		Intermec 6001 36TH AVENUE WEST EVERETT, WA 98203-9280 TITLE ANTENNA, 2.4GHZ, YAGI	
SIZE	CAGE CODE	DRAWING NUMBER	REV
D	33825	063365	D
SCALE	NONE	SHEET 1 OF 1	

APPROVED SOURCE(S) OF SUPPLY	
SUPPLIER	PART NUMBER
1. MOBILE MARK	SCR9-2400I
2.	
3.	
4.	
5.	
6.	

REVISIONS					
REV	ECN	ZONE	DESCRIPTION	DATE	DRAWN & APPROVED
A			-001 RELEASED AT REV A		

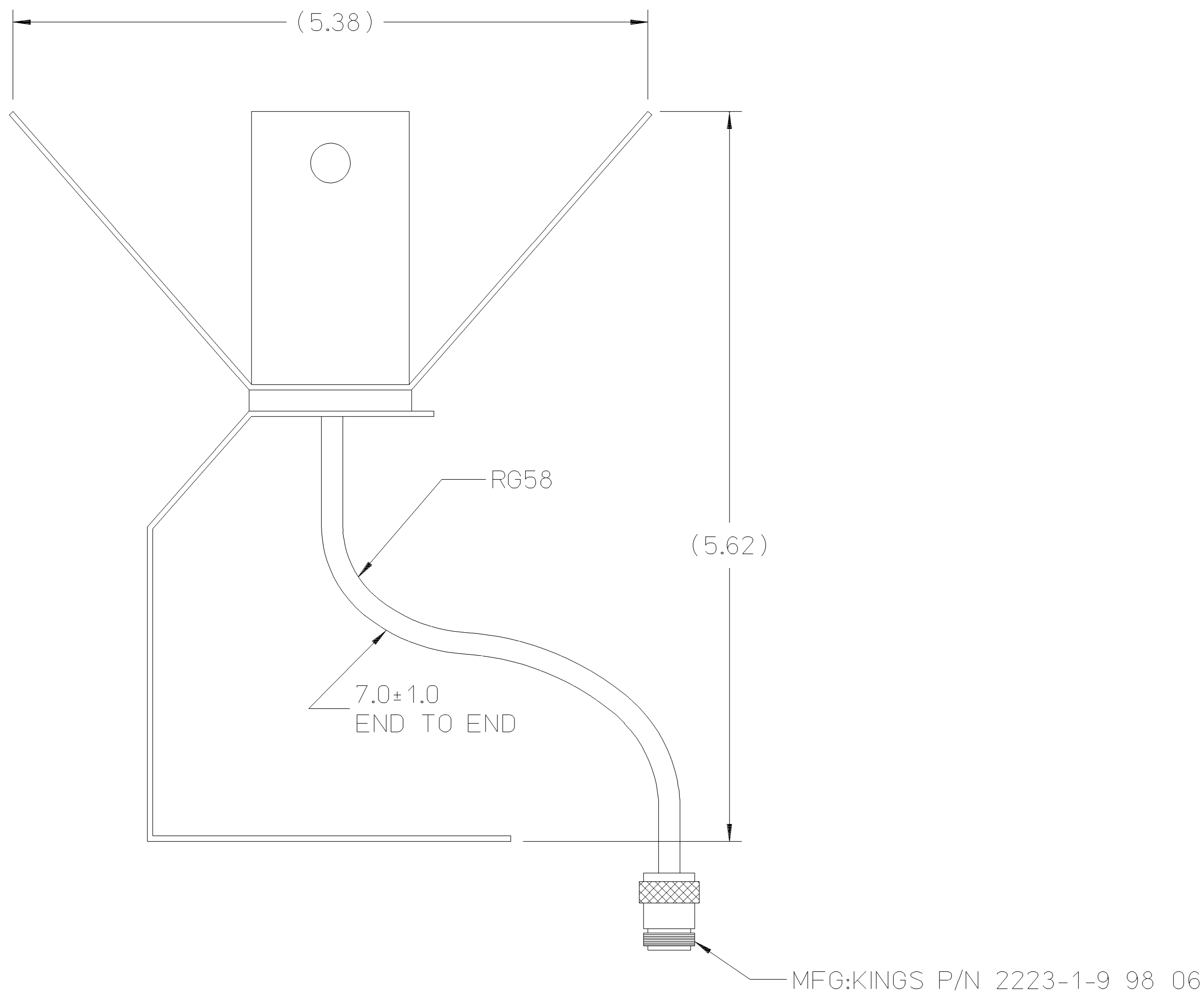

- NOTES: UNLESS OTHERWISE SPECIFIED
- REFER TO THE MANUFACTURER'S SPECIFICATIONS FOR COMPLETE DESIGN PARAMETERS.
 - BAG PARTS AND MARK BAG WITH 071122 TO WHICH MANUFACTURED PER SPECIFICATION 606427. DO NOT MARK DASH NUMBER.
 - CHANGES REQUIRE SAC APPROVAL.
 - SPECIFICATIONS:
 - * FREQUENCY RANGE: 2300-2600MHZ
 - * GAIN: 9dBi
 - * VSWR: 2:1
 - * IMPEDANCE: 50 ohms
 - * BEAMWIDTH 75° VERTICAL, 65° HORIZONTAL
 - * INPUT POWER (MAX): 100 WATTS
 - ANTENNA IS SUPPLIED WITH MOUNTING KIT AND INSTRUCTION SHEET.

RELEASED
SOURCE CONTROL DRAWING

-001

					REVISION	REV STATUS OF SHEETS
5	4	3	2	1	SHEET	

NOTICE

THIS DRAWING SHALL NOT BE DUPLICATED OR USED FOR ANY PURPOSE OTHER THAN THAT FOR WHICH PROVIDED. THE INFORMATION DISCLOSED HEREIN ORIGINATED BY AND IS THE PROPERTY OF INTERMEC TECHNOLOGIES CORPORATION AND EXCEPT FOR RIGHTS EXPRESSLY GRANTED BY WRITTEN CONSENT, SUCH INFORMATION SHALL NOT BE DISCLOSED OR DISSEMINATED WHOLE OR IN PART. INTERMEC TECHNOLOGIES CORPORATION RESERVES ALL PATENT, PROPRIETARY, DESIGN, USE, SALE, MANUFACTURING AND REPRODUCTION RIGHTS THERETO.

CAD DB.REF- 071122.1.a SYSTEM - HP-ME10		UNLESS OTHERWISE SPECIFIED, DIMENSIONS ARE IN INCHES.		APPROVALS		DATE		6001 36TH AVENUE WEST EVERETT, WA 98203-9280	
DRAWN	G.RAVEN	8-8-00	DRAWN		G.RAVEN	8-8-00	TITLE		
CHECKED	G.OPSTAD	8-29-00	CHECKED		G.OPSTAD	8-29-00	RESP ENG		R.ZIGLER
RESP ENG	R.ZIGLER	9-5-00	RESP ENG		R.ZIGLER	9-5-00	QA		-----
MFG ENG	V.LORD	9-20-00	MFG ENG		V.LORD	9-20-00	SAC		O.DREW
CE/ID	R.KELLY	9-12-00	CE/ID		R.KELLY	9-12-00	SIZE		C
SCALE		NONE	SCALE		NONE	USED ON		2100	SHEET 1 OF 1

7

6

5

4

3

2

1

APPROVED SOURCE(S) OF SUPPLY

SUPPLIER	PART NUMBER
1. MOBILE MARK	OD9-2400I
2.	
3.	
4.	
5.	
6.	

REVISION					REV STATUS	REVISIONS			
5	4	3	2	1	OF SHEETS	REV	DESCRIPTION	DATE	DRAWN & APPROVED
					SHEET	B	-001 RELEASED AT REV B		

NOTES: UNLESS OTHERWISE SPECIFIED

- MATERIAL: ANTENNA - FIBERGLASS RADOME WITH ALUMINUM FEED.
HARDWARE - 4 EACH U BOLTS (NOT SHOWN)
1 EACH MOUNTING PLATE (NOT SHOWN)
- REMOVE ALL BURRS AND SHARP EDGES.
- COSMETIC REQUIREMENTS PER SPECIFICATION 044856, APPENDIX C, CATEGORY II, CLASS B.
- BAG PARTS AND MARK BAG WITH 065349 PER SPECIFICATION 606427. DO NOT MARK DASH NUMBER.
- CHANGES REQUIRE SAC APPROVAL.
- SPECIFICATION:
FREQUENCY RANGE: 2300-2600MHZ
IMPEDANCE: 50+j0 OHMS (NOMINAL)
GAIN: 9dBi
BANDWIDTH @2:1 140MHZ
WIND SURVIVAL: 100+MPH
POWER RATING (CONTINUOUS): 100 WATTS MAX

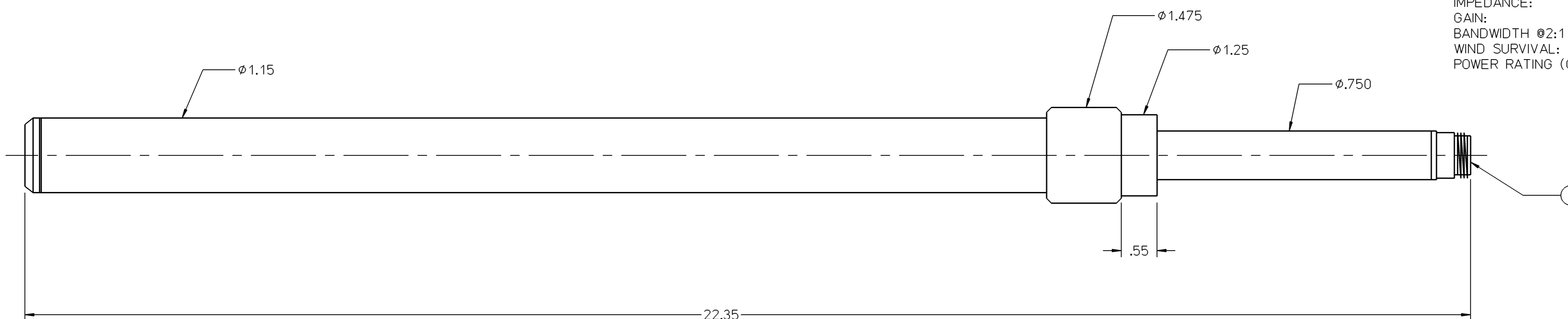

-001

SOURCE CONTROL DRAWING SEE SEPARATE PARTS LIST FOR 065349-001

CAD DB.REF- 065349.1.b SYSTEM - HP/ME30			
UNLESS OTHERWISE SPECIFIED, DIMENSIONS ARE IN INCHES.	APPROVALS	DATE	Intermec 6001 36TH AVENUE WEST EVERETT, WA 98203-9280
.XX ± .20	DRAWN J.FOTI	12-19-96	
.XXX ± .100	CHECKED R.HOAGLUND	1-28-97	TITLE ANTENNA, 2.4GHZ, 9DBI OMNI
ANGLES ±	RESP ENG M.CHIN	1-28-97	SIZE CAGE CODE DRAWING NUMBER REV
	QA R.SLOVEK	1-29-97	D 33825 065349 B
	MFG ENG M.SALATINO	1-28-97	SCALE NONE SHEET 1 OF 1
	SAC KEX	1-28-97	
	CMPNT ENGS.LOOMIS	1-28-97	

NOTICE
THIS DRAWING SHALL NOT BE DUPLICATED OR USED FOR ANY PURPOSE OTHER THAN THAT FOR WHICH PROVIDED. THE INFORMATION DISCLOSED HEREIN ORIGINATED BY AND IS THE PROPERTY OF INTERMEC CORPORATION AND EXCEPT FOR RIGHTS EXPRESSLY GRANTED BY WRITTEN CONSENT, SUCH INFORMATION SHALL NOT BE DISCLOSED OR DISSEMINATED WHOLE OR IN PART. INTERMEC CORPORATION RESERVES ALL PATENT, PROPRIETARY, DESIGN, USE, SALE, MANUFACTURING AND REPRODUCTION RIGHTS THERETO.

7

6

5

4

3

2

1

4

3

2

1

APPROVED SOURCE(S) OF SUPPLY

SUPPLIER	PART NUMBER
1. CENTURION	066147-001
2.	
3.	
4.	
5.	
6.	

REVISIONS

REV	DESCRIPTION	DATE	DRAWN & APPROVED
B	-001 RELEASED AT REV B		
C	-001 PER ECN 027276	03-07-98	J.LEE RCH
D	-001 PER ECN 100361	04-09-99	J.LEE JMB

NOTES: UNLESS OTHERWISE SPECIFIED

- BAG PARTS (25 MAX PER BAG) AND MARK BAG WITH 066147 AND DASH NUMBER TO WHICH MANUFACTURED PER SPECIFICATION 606427.
 - SPECIFICATIONS: FREQUENCY RANGE 2.4-2.5 GHZ
GAIN: 1.0 dBI
OPERATING TEMPERATURE: -40°C TO +85°C
FLEX TEST: PER QEA0014
PULL TEST: 20 LB LINEAR PULL
TORQUE TEST: 20 IN-LB
POWER RATING: 50 WATTS
VSWR 1.5:1 MAX AT RESONANCE
 - CHANGES REQUIRE SAC APPROVAL.
- 4 PART MARKED WITH AØ1.
- 5 THIS PIECE IS FREE TO ROTATE 360°.
- 6 FREE TO ROTATE 90° (DOWNWARD) ABOUT THIS PIVOT. LOCKS IN 0° AND 90° POSITION.
7. ALL PARTS OF ASSEMBLY ARE TO BE MOLDED BLACK OR BLACK CHROME.

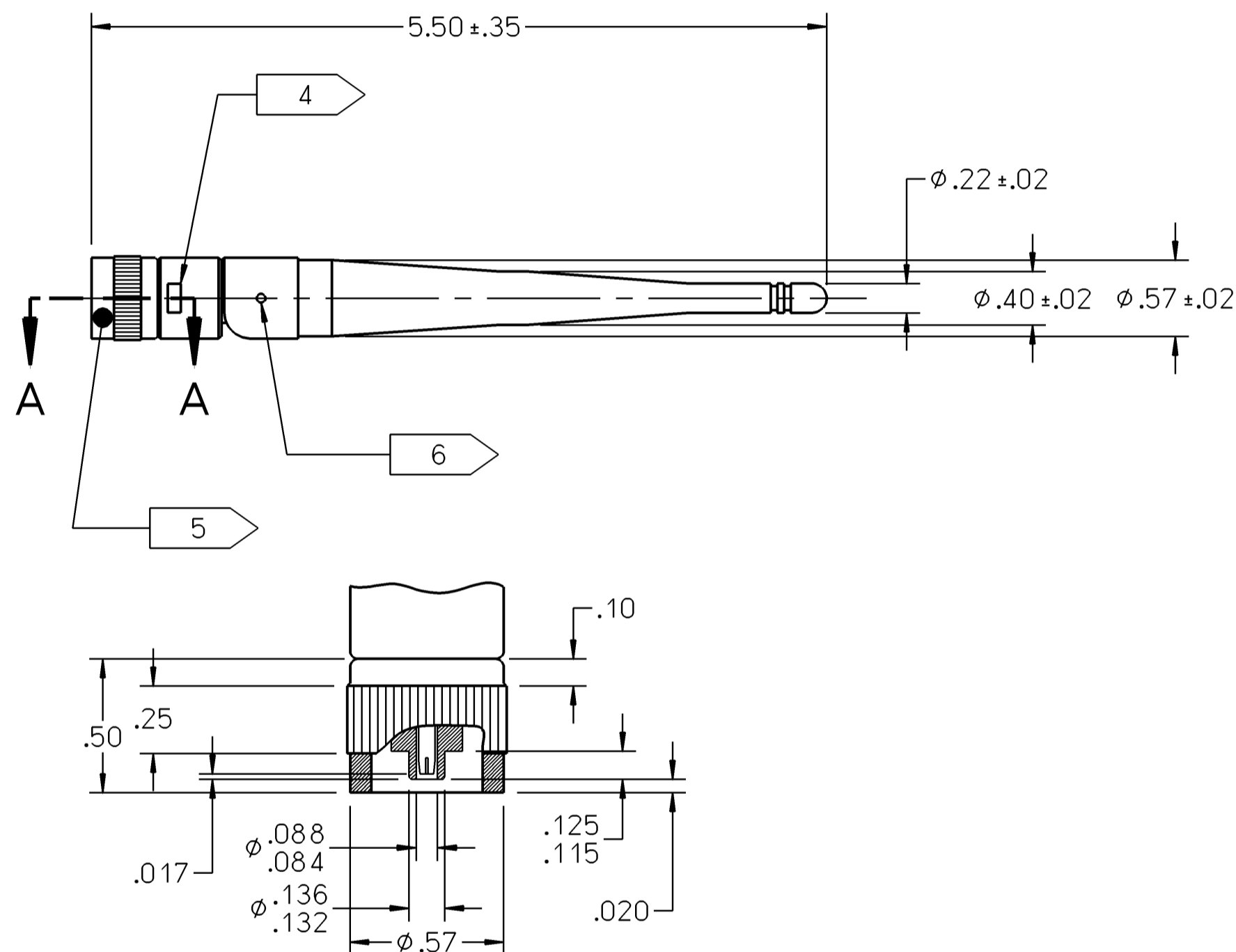

SECTION A-A

SCALE 2/1

-001

SOURCE CONTROL DRAWING

CAD DB.REF- 066147.1.d
SYSTEM - HP/ME30

UNLESS OTHERWISE SPECIFIED, DIMENSIONS ARE IN INCHES.

.XX ± .03

.XXX ± .010

ANGLES ±

APPROVALS	DATE
DRAWN G.RAVEN	7-11-97
CHECKED R.HOAGLUND	10-29-97
RESP ENG T.BENSON	10-30-97
QA T.ANDERSON	11-10-97
MFG ENG V.LORD	11-6-97
SAC O.DREW	10-30-97
CMPNT ENG R.KELLY	11-4-97

Intermec

6001 36TH AVENUE WEST
EVERETT, WA 98203-9280

TITLE ANTENNA, TNC, 2.4 GHZ,
DIPOLE, 248X

SIZE	CAGE CODE	DRAWING NUMBER	REV
C	33825	066147	D

NOTICE
THIS DRAWING SHALL NOT BE DUPLICATED OR USED FOR ANY PURPOSE OTHER THAN THAT FOR WHICH PROVIDED. THE INFORMATION DISCLOSED HEREIN ORIGINATED BY AND IS THE PROPERTY OF INTERMEC CORPORATION AND EXCEPT FOR RIGHTS EXPRESSLY GRANTED BY WRITTEN CONSENT, SUCH INFORMATION SHALL NOT BE DISCLOSED OR DISSEMINATED WHOLE OR IN PART. INTERMEC CORPORATION RESERVES ALL PATENT, PROPRIETARY, DESIGN, USE, SALE, MANUFACTURING AND REPRODUCTION RIGHTS THERETO.

4

3

2

1

SCALE 1/1 SHEET 1 OF 1

APPROVED SOURCE(S) OF SUPPLY	
SUPPLIER	PART NUMBER
1. CENTURION INTL	CAF94120
2.	
3.	
4.	
5.	
6.	

REVISIONS			
REV	DESCRIPTION	DATE	DRAWN & APPROVED
B	-001 RELEASED AT REV B		
C	-001 PER ECN 102232	3-7-01	G.RAVEN GMO

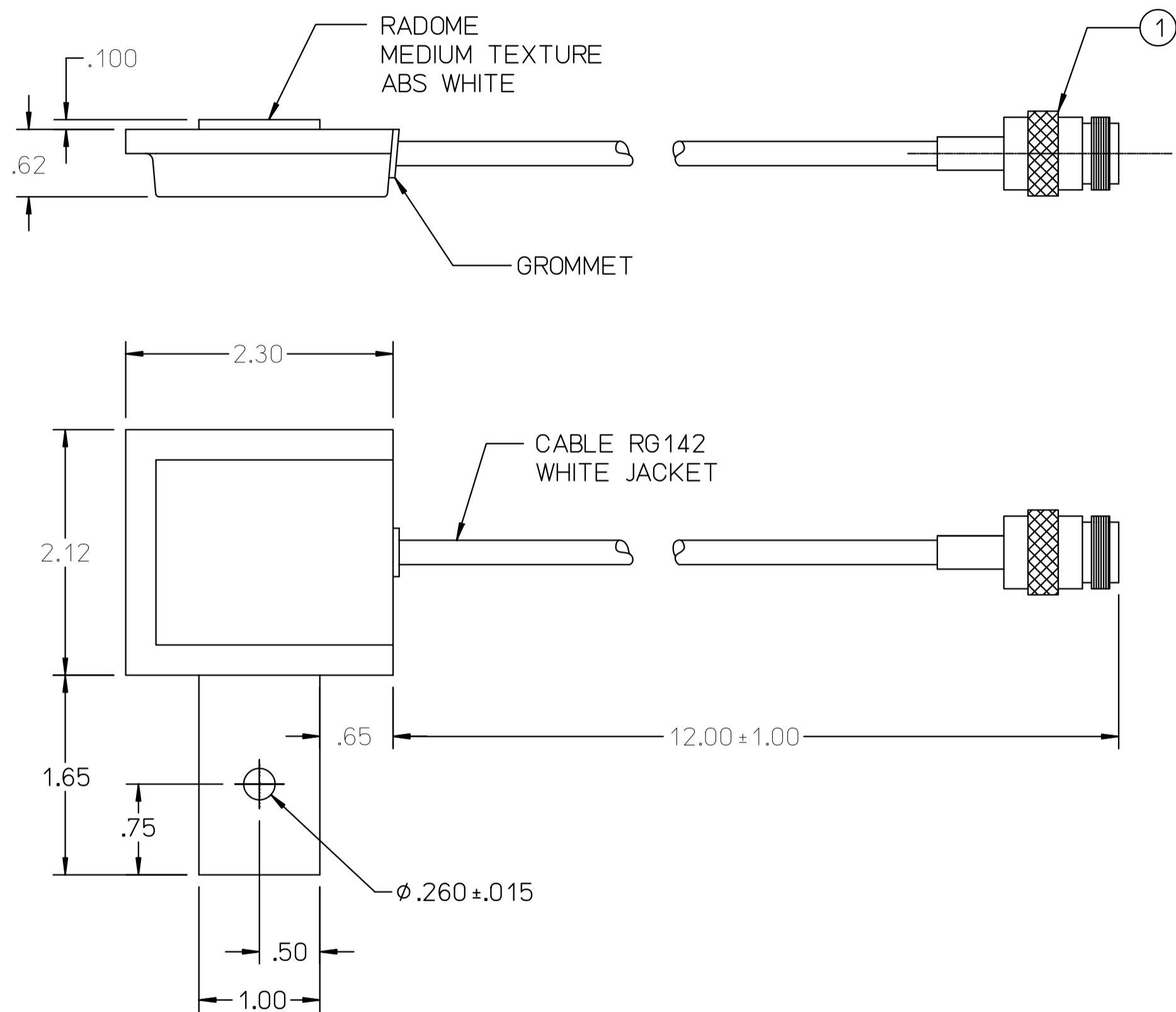

NOTES: UNLESS OTHERWISE SPECIFIED

- REFER TO THE MANUFACTURER'S SPECIFICATIONS FOR COMPLETE DESIGN PARAMETERS.
- BAG PARTS AND MARK BAG WITH 067261 TO WHICH MANUFACTURED PER SPECIFICATION 606427. DO NOT MARK DASH NUMBER.
- CHANGES REQUIRE SAC APPROVAL.
- SPECIFICATIONS:
 - * VSWR: 1.5:1
 - * FREQUENCY: 2400-2500 MHz
 - * GAIN: 3 dBi
 - * BEAMWIDTH 3dB
 - H-PLANE 360°
 - E-PLANE 180°
 - * PATTERN: OMNI-DIRECTIONAL
 - * OPERATION TEMPERATURE: -40°C TO +100°C
 - * MAXIMUM INPUT POWER: 50 WATTS
- MOUNTING KIT SUPPLIED.

SOURCE CONTROL DRAWING
 SEE SEPARATE PARTS LIST FOR 067261-001

-001

NOTICE

THIS DRAWING SHALL NOT BE DUPLICATED OR USED FOR ANY PURPOSE OTHER THAN THAT FOR WHICH PROVIDED. THE INFORMATION DISCLOSED HEREIN ORIGINATED BY AND IS THE PROPERTY OF INTERMEC TECHNOLOGIES CORPORATION AND EXCEPT FOR RIGHTS EXPRESSLY GRANTED BY WRITTEN CONSENT, SUCH INFORMATION SHALL NOT BE DISCLOSED OR DISSEMINATED WHOLE OR IN PART. INTERMEC TECHNOLOGIES CORPORATION RESERVES ALL PATENT, PROPRIETARY, DESIGN, USE, SALE, MANUFACTURING AND REPRODUCTION RIGHTS THERETO.

CAD DB.REF- 067261.1.c SYSTEM - HP/ME30		UNLESS OTHERWISE SPECIFIED, DIMENSIONS ARE IN INCHES.		APPROVALS		DATE	 6001 36TH AVENUE WEST EVERETT, WA 98203-9280
DRAWN J.FOTI		5-11-98		CHECKED R.HOAGLUND		5-21-98	
RESP ENGM.SHAVER		6-2-98		QA T.ANDERSON		6-2-98	TITLE
MFG ENGM.SALATINO		5-26-98		SAC P.HELTON		5-26-98	ANTENNA, 2.4GHZ, 3dBI MINI OMNI
CMPNT ENG T.KEY		5-27-98		SIZE	CAGE CODE	DRAWING NUMBER	REV
				C	33825	067261	C
				SCALE	NONE	SHEET 1 OF 1	

4

3

2

1

APPROVED SOURCE(S) OF SUPPLY

SUPPLIER	PART NUMBER
1. CENTURION INTL	CAF95989
2.	
3.	
4.	
5.	
6.	

REVISIONS

REV	DESCRIPTION	DATE	DRAWN & APPROVED
B	-001 RELEASED AT REV B		
C	-001 PER ECN 102232	3-7-01	G.RAVEN GMO

D

D

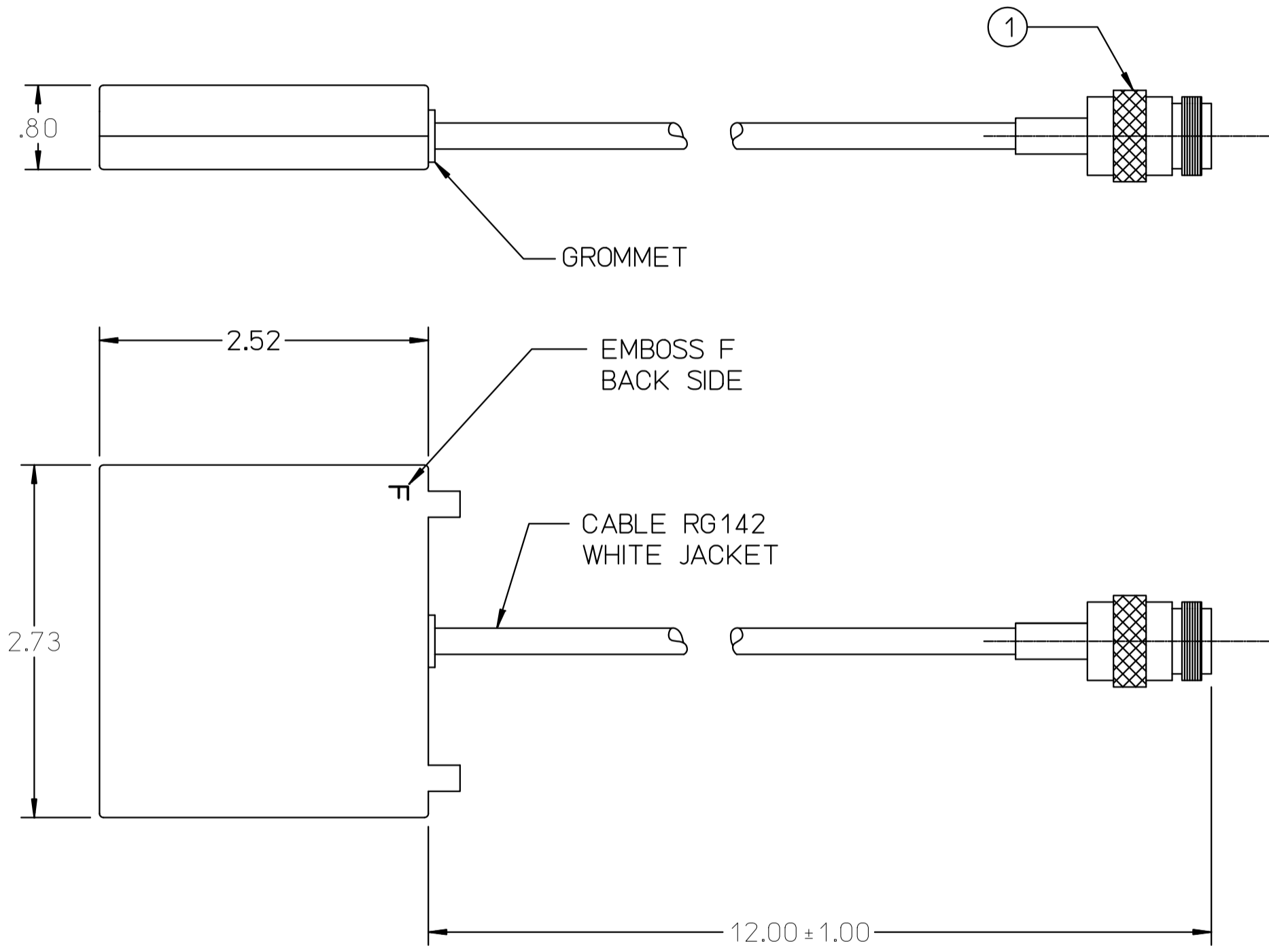

NOTES: UNLESS OTHERWISE SPECIFIED

- REFER TO THE MANUFACTURER'S SPECIFICATIONS FOR COMPLETE DESIGN PARAMETERS.
- BAG PARTS AND MARK BAG WITH 067262 TO WHICH MANUFACTURED PER SPECIFICATION 606427. DO NOT MARK DASH NUMBER.
- CHANGES REQUIRE SAC APPROVAL.
- SPECIFICATIONS:
 - * FREQUENCY RANGE: 2400-2500 MHz
 - * GAIN: 5dBi
 - * VSWR: 1.8:1
 - * IMPEDANCE: 50ohms
 - * BEAMWIDTH 5 dB
 - H-PLANE: 55°
 - E-PLANE: 80°
 - * OPERATING TEMPERATURE: -40°C TO +100°C
 - * INPUT POWER (MAX): 50 WATTS
- MOUNTING KIT SUPPLIED.

C

C

B

B

SOURCE CONTROL DRAWING

SEE SEPARATE PARTS LIST FOR 067262-001

A

A

-001

NOTICE

THIS DRAWING SHALL NOT BE DUPLICATED OR USED FOR ANY PURPOSE OTHER THAN THAT FOR WHICH PROVIDED. THE INFORMATION DISCLOSED HEREIN ORIGINATED BY AND IS THE PROPERTY OF INTERMEC TECHNOLOGIES CORPORATION AND EXCEPT FOR RIGHTS EXPRESSLY GRANTED BY WRITTEN CONSENT, SUCH INFORMATION SHALL NOT BE DISCLOSED OR DISSEMINATED WHOLE OR IN PART. INTERMEC TECHNOLOGIES CORPORATION RESERVES ALL PATENT, PROPRIETARY, DESIGN, USE, SALE, MANUFACTURING AND REPRODUCTION RIGHTS THERETO.

CAD DB.REF- 067262.1.c SYSTEM - HP/ME30		UNLESS OTHERWISE SPECIFIED, DIMENSIONS ARE IN INCHES.		APPROVALS		DATE		 6001 36TH AVENUE WEST EVERETT, WA 98203-9280	
.XX ± .12		.XXX ±		ANGLES ±		DRAWN J.FOTI 5-11-98		TITLE ANTENNA, 2.4GHZ, 5dBi DUAL FLAT PANEL	
DRAWN J.FOTI 5-11-98		CHECKED R.HOAGLUND 5-21-98		RESP ENGM.SHAVER 6-2-98		QA T.ANDERSON 6-2-98		MFG ENG M.SALATINO 5-26-98	
SAC P.HELTON 5-26-98		CMPNT ENG T.KEY 5-27-98		SCALE NONE		SIZE C CAGE CODE 33825		DRAWING NUMBER 067262	
						REV C		SHEET 1 OF 1	

4

3

2

1

APPROVED SOURCE(S) OF SUPPLY	
SUPPLIER	PART NUMBER
1. CENTURION INTL	CAF95972
2.	
3.	
4.	
5.	
6.	

REVISIONS			
REV	DESCRIPTION	DATE	DRAWN & APPROVED
B	-001 RELEASED AT REV B		
C	-001 PER ECN 102232	3-7-01	G.RAVEN GMO

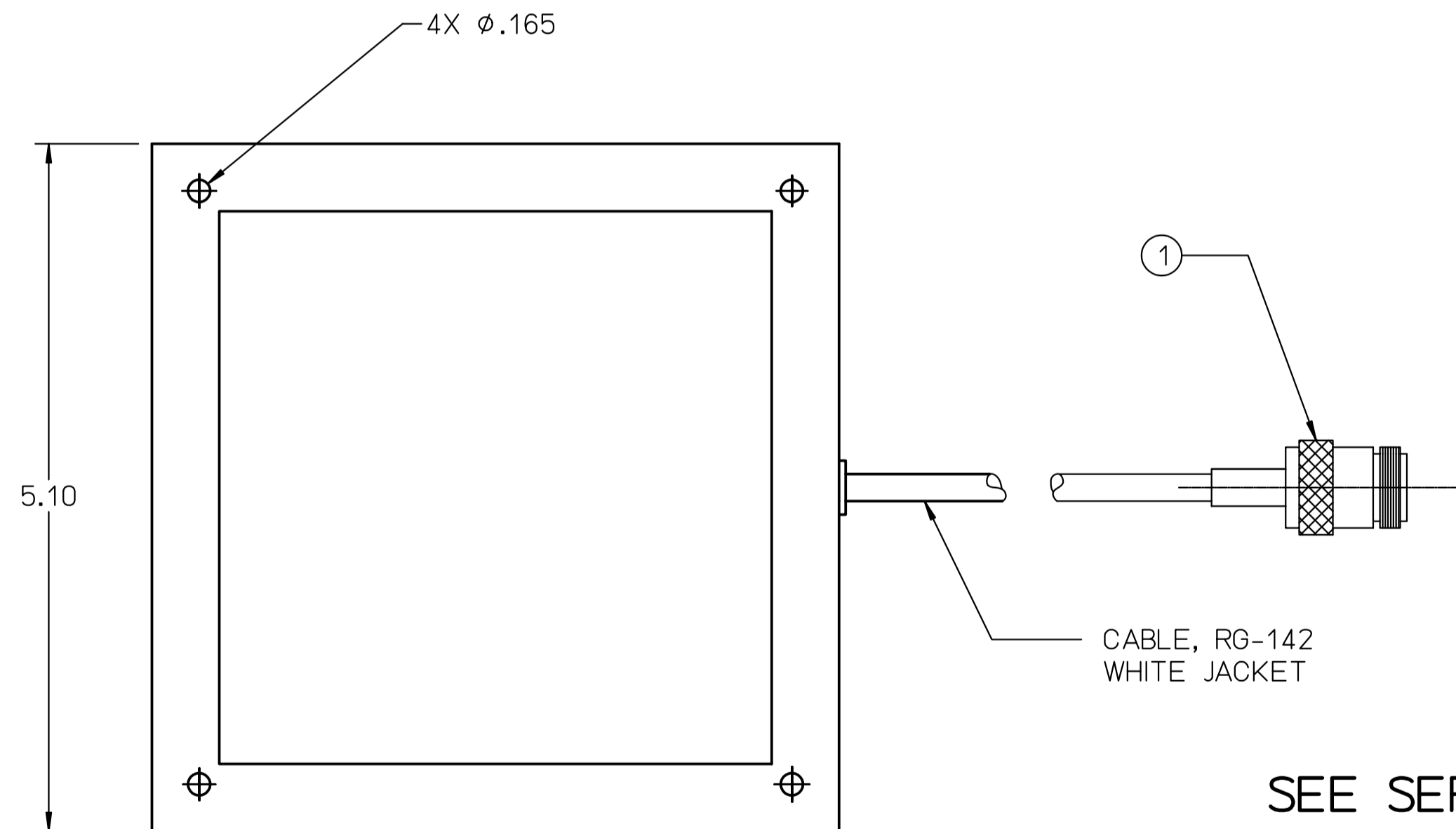
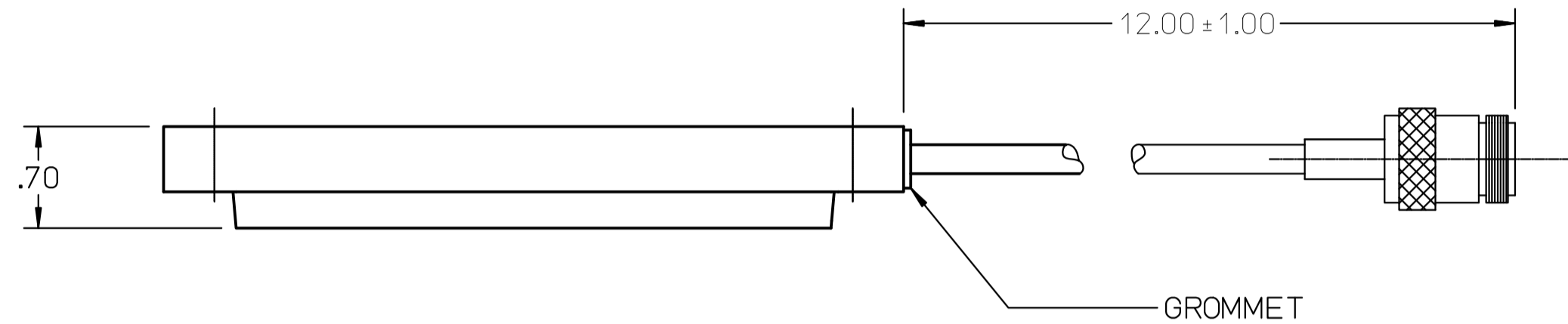

NOTES: UNLESS OTHERWISE SPECIFIED

- REFER TO THE MANUFACTURER'S SPECIFICATIONS FOR COMPLETE DESIGN PARAMETERS.
- BAG PARTS AND MARK BAG WITH 067263 TO WHICH MANUFACTURED PER SPECIFICATION 606427. DO NOT MARK DASH NUMBER.
- CHANGES REQUIRE SAC APPROVAL.
- SPECIFICATIONS:
 - * FREQUENCY RANGE: 2400-2500MHZ
 - * GAIN: 9dBi
 - * VSWR: 1.5:1
 - * IMPEDANCE: 50 ohms
 - * BEAMWIDTH 9dB
 - H-PLANE: 60°
 - E-PLANE; 60°
 - * INPUT POWER (MAX): 50 WATTS
 - * OPERATING TEMPERATURE: -40°C TO +100°C
 - * FRONT/BACK RATIO: 20 dBi
- MOUNTING KIT SUPPLIED.

SOURCE CONTROL DRAWING
 SEE SEPARATE PARTS LIST FOR 067263-001

-001

NOTICE

THIS DRAWING SHALL NOT BE DUPLICATED OR USED FOR ANY PURPOSE OTHER THAN THAT FOR WHICH PROVIDED. THE INFORMATION DISCLOSED HEREIN ORIGINATED BY AND IS THE PROPERTY OF INTERMEC TECHNOLOGIES CORPORATION AND EXCEPT FOR RIGHTS EXPRESSLY GRANTED BY WRITTEN CONSENT, SUCH INFORMATION SHALL NOT BE DISCLOSED OR DISSEMINATED WHOLE OR IN PART. INTERMEC TECHNOLOGIES CORPORATION RESERVES ALL PATENT, PROPRIETARY, DESIGN, USE, SALE, MANUFACTURING AND REPRODUCTION RIGHTS THERETO.

CAD DB.REF- 067263.1.c SYSTEM - HP/ME30		
UNLESS OTHERWISE SPECIFIED, DIMENSIONS ARE IN INCHES.	APPROVALS	DATE
.XX ± .12	DRAWN J.FOTI	5-12-98
.XXX ± .015	CHECKED R.HOAGLUND	5-21-98
ANGLES ±	RESP ENGM.SHAVER	6-2-98
	QA T.ANDERSON	6-2-98
	MFG ENG M.SALATINO	5-26-98
	SAC P.HELTON	5-21-98
	CMPNT ENG T.KEY	5-27-98

Intermec Technologies Corporation		6001 36TH AVENUE WEST EVERETT, WA 98203-9280	
TITLE ANTENNA, 2.4GHZ, 9dBi FLAT PANEL			
SIZE	CAGE CODE	DRAWING NUMBER	REV
C	33825	067263	C
SCALE	NONE		SHEET 1 OF 1



Positioning Antennas



This appendix provides information about positioning the antennas for the Wireless Access Points. Specific guidelines for antenna separation are provided for those configurations that have multiple antennas.

Antenna Placement Guidelines

Every environment is unique with different obstacles and materials. Therefore, the exact range that you will achieve with your UAP is difficult to determine. Intermec recommends that you allow an Intermec-certified RF specialist to perform a site survey before you install a wireless network. For more information on site surveys, contact your local Intermec representative.

Radio signals may reflect off some obstacles and be absorbed by others. For example, two radios may achieve up to 305 meters (1,000 feet) of range if positioned outdoors within line of sight, with no obstacles between them. However, the same two units may only achieve up to 152 meters (500 feet) of range when the RF signal has to travel through items such as cubicles. If the signal must penetrate office walls, the signal range may decrease to 91 meters (300 feet).

Proper antenna placement can help improve range. If you are interested in antenna options, contact your Intermec representative about antenna kits. Here are some general guidelines for positioning antennas:

- Place the antenna as high as possible. In an office environment, try to place it above cubicle walls.
- Do not place a sheet of metal (such as a filing cabinet) between two antennas.

The following sections provide detailed information about antenna placement for those UAPs that can have more than one antenna.

Positioning the Antennas for a 2.4 GHz OpenAir WAP

Because the 2.4 GHz OpenAir WAP has two radios installed in the device, you need to pay particular attention to the placement of the two antennas. Proper positioning of the antennas is critical for proper functioning of the WAP. You attach antenna cables to the 2110, and then attach the cables to antennas mounted in your work environment.

There are two types of Intermec-recommended antennas you can use:

- Omni
- Directional

You can position the antennas in one of three ways:

- Horizontal. Both antennas are mounted in the same plane (at the same height).
- Stacked. One antenna is mounted directly above the other.
- Angled. The two antennas are mounted some distance apart and at different heights.

21XX Universal Access Point Technical Reference Manual

You can use either two omni antennas, two directional antennas, or one omni antenna and one directional antenna. The following table shows the MINIMUM distance that must exist between the two antennas.

Position	2 Omni Antennas	2 Directional Antennas	1 Omni, 1 Directional Antenna
Horizontal	3dBi omni, 3 meters (10 feet) 6dBi omni, 6.1 meters (20 feet) 9dBi omni, 12.2 meters (40 feet)	3 meters (10 feet)	6.1 meters (20 feet)
Stacked	.6 meters (2 feet)	(does not apply)	.6 meters (2 feet)
Angled	1.1 meters (3.5 feet) vertically and 7.3 meters (24 feet) horizontally	.6 meters (2 feet) vertically and 3 meters (10 feet) horizontally	.6 meters (2 feet) vertically and 6.1 meters (20 feet) horizontally

Note these additional points about positioning your antennas:

- Intermec recommends that you mount omni antennas so they point down.
- If you are using one omni antenna and one directional antenna, you should mount the directional antenna so that it points away from the omni antenna.
- If you are using one omni antenna and one directional antenna in the stacked position, you must mount the directional antenna above the omni antenna.
- If you are using two directional antennas, you must mount them back-to-back.

Positioning the Antennas for an IEEE 802.11 DS Radio

The IEEE 802.11 DS radio features antenna diversity, which means that each radio has two antennas. One antenna functions as a receive antenna and the other antenna functions as both a transmit and a receive antenna. Note that only one antenna is used at a time in a diversity system.

On an IEEE 802.11 DS radio, the centermost antenna is the antenna that both transmits and receives radio signals. If you attach only one antenna to the IEEE 802.11 DS radio, you should attach it to the centermost antenna connector for that radio card.

If you are using two antennas for your IEEE 802.11 DS WAP, placement of the antennas is critical because each antenna has a particular function. Antennas placed too close together may cause interference with each other. Antennas placed too far apart may not be able to establish two-way communications with other radios. To achieve optimum placement for the two antennas, you must place the transmit/receive antenna so that it is within range of all the radios that the receive-only radio can hear.



Note these important points about antenna placement for an IEEE 802.11 DS radio:

- Use the recommended antenna separation for placement of either omni or directional antennas.
- Position directional antennas so they point in the same direction.
- Follow the recommended antenna separation precisely when using the closest distances. Movement of as little as 3.05 centimeters (1.2 in) may strongly affect performance.
- Position the antennas so that both antennas are within range of the radios they need to communicate with.
- Do not position the two antennas around a corner or so that a wall is between them.

The recommended antenna separation is listed in the following table. You should choose the greatest distance possible within the constraints of your environment.

Location	Recommended Antenna Separation
Highly reflective warehouse environment	.33 m (13 in) or .64 m (25 in)
Moderately reflective warehouse environment	.64 m (25 in), 1.22 m (4 ft), or 1.83 m (6 ft)
Open/Office environment	1.22 m (4 ft) to 3.05 m (10 ft)

